

Operator's Manual

VALTRA

Series BM

Tractor

BM110

BM125i



Mogi

**AGCO do Brasil - Rua Capitão Francisco de Almeida,
695 - Mogi das Cruzes/SP**

VALTRA is a worldwide brand of AGCO

© AGCO 2016

Original Operator's Manual

January 2016

87659000

SA

English

TABLE OF CONTENTS

Safety	1
Introduction	2
Operation	3
Maintenance	4
Diagnosis of faults	5
Specifications	6
Accessories	7

1. Safety

1.1 Introduction	11
1.2 General Recommendations	12
1.2.1 The tractor	12
1.2.2 Safety notes	12
1.2.3 Note to the operator	12
1.2.4 Roll-Over Protective Structure (ROPS)	13
1.2.5 Safe maintenance	14
1.2.6 Fuel	14
1.3 Follow a safety program	16
1.3.1 For proper operation	16
1.4 Prepare yourself for safe operation	17
1.4.1 Know your equipment	17
1.4.2 Protect yourself	17
1.4.3 Use the safety devices and protection available	17
1.4.4 Check the equipment	18
1.4.5 Cleaning the tractor	19
1.4.6 Protect the environment	19
1.5 Start-up	20
1.5.1 Prior to start-up	20
1.5.2 How to mount and dismount the machine safely	20
1.5.3 Safe start-up	21
1.5.4 Test the controls	21
1.5.5 Starting fluid	22
1.6 Safe operation	23
1.6.1 Manoeuvre correctly	23
1.6.2 Safety practices	23
1.6.3 Rollover risk	24
1.6.4 To prevent rear rollover	25
1.6.5 To prevent side rollovers	25
1.6.6 Emergency brake	26
1.6.7 General operating hazards	26
1.6.8 Implements and additional equipment	27
1.6.9 Towing with the tractor	27
1.6.10 Noise level	28
1.7 Road Transport	29
1.7.1 Rules of the Road	29
1.8 Quality policy	30
1.8.1 Main guidelines	30
1.8.2 ISO 14000	30
1.8.3 Environmental Management System	30
1.8.4 Environmental issues	30
1.8.5 Recommendations for tractor users and customers	31
1.8.6 CONAMA Resolution	32
1.9 Diesel fuel B	33
1.9.1 Use of diesel fuel B	33
1.9.2 Additive for DIESEL PRO fuel	33
1.9.3 DIESEL GUARD fuel biocide	34

1.1 Introduction

Always consult the dealer if any part of the manual is not understood. It is extremely important that these instructions are understood and followed.

Daily maintenance should become a routine. Always keep a record of the service hours. When ordering new parts, use only original Valtra parts. The Valtra dealer network provides original parts and can give instructions for installation and use. Using low quality parts can seriously damage the equipment.

We recommend that customers buy service parts from authorised Valtra dealers only.

Due to variations in operating conditions, it is impossible for the manufacturer to make comprehensive or definitive statements in its publications with respect to the performance or usage methods of its machines, or to be responsible for any damages or losses arising from such statements, errors or omissions.

To prevent the warranty being invalidated, consult your Valtra dealer for special instructions if the tractor will be used in special conditions that may be harmful (use in deep waters or in flooded fields, for example). These products were designed for agricultural applications only (appropriate use). Any other use shall be considered inappropriate.

Valtra is not liable for damage to property or personal injuries caused by improper use. The user must take full responsibility for the consequences of misuse.

Conformity and full adherence to the operation, service and maintenance requirements specified by Valtra are essential factors for appropriate use.

1.2 General Recommendations

Why is safety important?

1. Accidents incapacitate and can be fatal
2. Accidents generally involve significant costs
3. Accidents can be avoided.

This section of the Manual is intended to point out some of the basic safety situations involved with your equipment and to provide suggestions on how to avoid high-risk situations and accidents. Therefore, users must take all possible precautions and guidance. There are always a series of precautions to be taken for each implement, attachment and work situation, which would be impossible to list in this Manual.

Valtra is in no way able to directly control the conditions of use, servicing or repair to which the product is subjected. Therefore, users are responsible for always following appropriate practices for their safety and for the integrity of the product, other people or machines in the same work area.

1.2.1 The tractor

The tractor is a source of mechanical and hydraulic power.

- On its own, the tractor has little practical value. It only becomes a work unit when used in conjunction with an implement or other accessory.
- This Maintenance Guide was compiled to cover the safety practices when the tractor is operating under normal conditions.
- This manual does not address all operating and safety instructions relating to all known implements and accessories, which may be installed when the tractor is delivered or on another date.
- It is essential that operators read and understand the manuals of the related implements and accessories.

1.2.2 Safety notes

Always pay attention to the symbols below. When they appear next to text, pay special attention to the instructions.

**DANGER:**

This symbol indicates an imminently hazardous situation that, if not avoided, will result in death or serious injury.

**WARNING:**

This symbol indicates a situation of potential danger that, if not avoided, may result in death or serious injury.

**CAUTION:**

This symbol indicates a situation of potential danger that, if not avoided, may result in minor or moderate injury.

IMPORTANT: *This symbol identifies specific instructions or procedures that, if not strictly observed, may result in damage to or destruction of the machine, the operating process or even objects that are close to it.*

NOTE: *This symbol indicates additional information about a matter or procedure that will make the operation or repair more appropriate or efficient.*

1.2.3 Note to the operator

It is your responsibility to read and understand the safety section of this Manual before operating the machine. You must follow the safety instructions that will guide you, step by step, throughout your working day.

Remember that you play a crucial part in ensuring that operation of the machine is safe. Good safety practices not only protect you, but also the people around you. Carefully read the safety practices contained in this Manual and include them in your safety program.

Remember that this safety section was prepared especially for this machine. Follow all usual and customary safety precautions and, above all, remember that your safety depends on you. You can prevent accidents.

1.2.4 Roll-Over Protective Structure (ROPS)

NOTE: *The roll-over protective structure (ROPS) is tested and approved pursuant to the Brazilian ABNT NBR ISO 5700 - Roll-Over Protective Structure (ROPS) standard and the international ISO 5700 standard.*

The ROPS is designed to protect the operator in the event that the tractor rolls over. The top of the ROPS can be folded for transport by truck, or when the tractor is being used in field conditions where height limits its use. When the ROPS is folded, the safety belt should not be used. Take extra care in these conditions. The structure does not protect the operator when in the folded position.

The ROPS must always be kept in a vertical position, unless you are operating in the situations described above.

Always keep the ROPS in a vertical position and latched. In this condition, the safety belt should be used and latched.

If the ROPS is damaged during operation:

- Do not:
 - Weld, drill, fold or detach.
 - Use the tractor with the damaged ROPS.
 - Attach chains, ropes or cables to the frame to pull anything. Only pull from the tractor draw bar.
- Do:
 - Make sure that the structure is properly attached to the tractor.
 - Ensure that all components are in order, to provide the desired protection
 - Only use original Valtra parts to ensure the integrity of the structure during its maintenance.

The following additional safety precautions must be strictly observed:



CAUTION:

- **Use a seat belt at all times, except when the top part of the structure is folded. Adjust the belt comfortably.**
- **If the tractor rolls over, hold the steering wheel firmly. Do not attempt to jump from the tractor. However, if the ROPS is folded, leave the tractor immediately.**
- **Ensure that the safety decals are unobstructed or covered for future reference at all times.**
- **A plastic canopy does not protect the operator against falling objects.**

1.2.5 Safe maintenance

- Do not perform any repair or maintenance service with the engine running or still hot, or with the tractor in motion.
- Before making adjustments or repairing the electrical system, disconnect the battery cables: The negative (-) cable first.
- To prevent fires or explosions, keep open flames away from the battery or cold start aid devices. To prevent sparks, which can cause explosions, use bridge cables in accordance with the instructions provided in this manual.
- When performing repairs or adjustments, it is recommended that you consult a Valtra dealer so the work may be carried out by trained personnel.



Fig. 1

- The implement and/or tractor must be placed on wooden blocks or suitable stands, never on a hydraulic jack.
- Periodically check the tightness of all nuts and bolts, especially wheel hub and rim nuts. Tighten to the recommended torques.

1.2.6 Fuel

Storage, handling and cleaning

The purity and cleanliness of fuel are vital to the proper operation of the engine and the durability of the injection system. Therefore, to ensure that your fuel meets the requirements, follow the recommendations below:

- Use reservoirs equipped with two taps, one on each end. Plastic tanks are preferable. In the case of metallic tanks, use stainless steel tanks or tanks with an appropriate inside coating—not zinc—because it contaminates the fuel, affecting the life of the injection systems and engine.
- Never use galvanized tubes, registers, tanks or vessels because the coating reacts with the diesel, forming residues.
- The drum or reservoir in use must be protected from the sun, rain and dust. It must also be supported on stands and in a horizontal position, at a slight angle, so that the discharge side is around 10 cm higher than the other side. Thus, any water and impurities will be deposited at the bottom, being discharged by the tap on the opposite end.
- The reservoirs must have a waterproof vent located at the higher end.

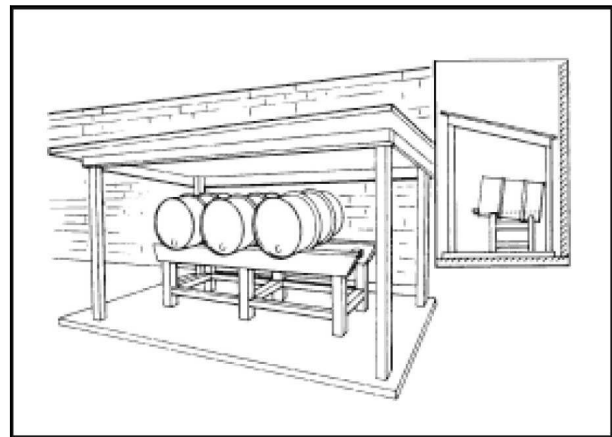

Fig. 2

- Ideally, two drums, each with capacity for a week of fuel, should be used. After filling, the oil must rest for two to three days for the impurities settle to the bottom. Thus, while one rests, the other is being used. If larger tanks are used, there must be an upper cover (1) for cleaning, at least 40 mm in diameter.
- The point for filling the tank (2) should be easily accessible and at least 65 mm in diameter. If there is a tube, it should end 15 cm from the bottom and may be equipped with a filter. The end cap should be the same as that used in vehicle tanks.

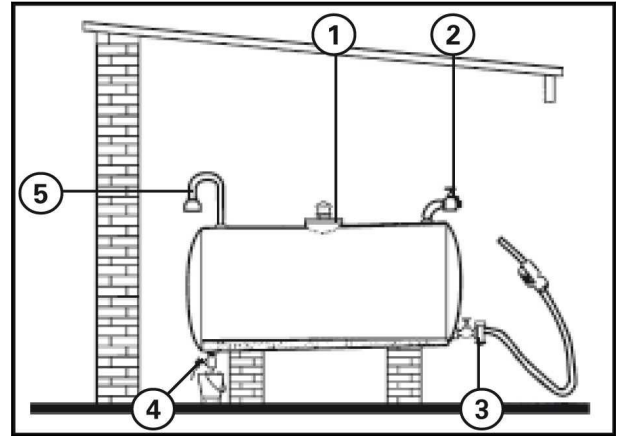

Fig. 3

- A vent with a minimum diameter of 80 mm and fitted with a protective filter (5) should be installed in the upper part of the tank.
- The vehicle filling outlet (3) must be installed on the higher side of the drum, 80 mm from the bottom.
- Post clearly visible signs with the words:



DANGER:
Flammable - No smoking

IMPORTANT: Follow the maintenance procedures to keep the equipment in good condition.

1.3 Follow a safety program

1.3.1 For proper operation

To ensure that the agricultural equipment operates correctly, it must be operated by qualified and authorised personnel. To qualify, you must understand the instructions provided in this Manual, receive the proper training and know the rules and safety regulations related to your work.

These regulations include, but are not limited to, the following instructions for safe operation:



DANGER:

Use of drugs or alcohol. May affect awareness or coordination. If the operator is taking prescription or non-prescription medication, he or she should see a doctor to find out if his/her ability to operate the machine may be adversely affected by such medication.

IMPORTANT:

Operator's Manual for any kit or implement. Find out if there is a manual and carefully read the additional safety information.

Follow the following instructions:

- Do not allow children or people not qualified for the job to operate the tractor. Keep people away from the work area.
- Always use the safety belt.
- When possible, avoid operating the tractor near ditches, earthwork or holes. Reduce speed when turning, when going up or down slopes or hills and on rough, slippery or muddy surfaces.
- Avoid very steep hills.
- Pay close attention to where you are going, especially at the end of rows, on the roads or when operating close to trees.
- The instructor's seat must be used only for short periods.
- Do not allow children in the instructor's seat.
- Do not give rides on the machine or implement, unless there is a proper instructor's seat.
- The implement must only be coupled to the draw bar or recommended hitch points and never above the center line of the rear axle.
- Operate the tractor slowly and with caution - without sudden maneuvers, starts or stops. When the tractor is stopped, engage the park brake. Lower the implement and remove the key from the ignition.
- Do not modify or remove any part of the equipment and do not use attachments that are not suitable for the tractor.

1.4 Prepare yourself for safe operation

1.4.1 Know your equipment

Know your tractor, learn how to operate all of the parts of your machine and the implements and accessories used with it. Know how to operate all of the controls, gauges, instruments and commands. Learn about the nominal load capacity, the speed range, the braking capacity and the steering features of your machine, as well as the turning radius and the operating clearances.

Do not forget that rain, snow, gravel, very soft soils etc. can alter how the tractor operates.

In poor operating conditions, drive more slowly and be even more careful. Engage the front-wheel drive, if fitted.



Fig. 4

Study the Danger, Warning, Caution and Care safety decals located in your tractor, as well as the information decals.

Read this maintenance guide before you turn on the engine. Read it thoroughly before starting work. If you do not understand any information contained in this guide, ask someone for an explanation before you start the work.

This manual covers all the general safety practices for this agricultural machine. It should always be kept inside the equipment. If you require extra copies, please contact your dealership.

1.4.2 Protect yourself

Use appropriate protective clothing and devices for your work. Do not take risks. You will need:

- A hardhat
- Protective goggles or mask
- Hearing protection
- Respirator or filtering mask
- Special clothing for very cold days
- Reflective clothing
- Heavy gloves (neoprene for chemicals or leather for heavy work)
- Boots

Do not wear loose clothing, jewellery or other items that may get caught on controls or other parts of the tractor. If you have long hair, tie it back.

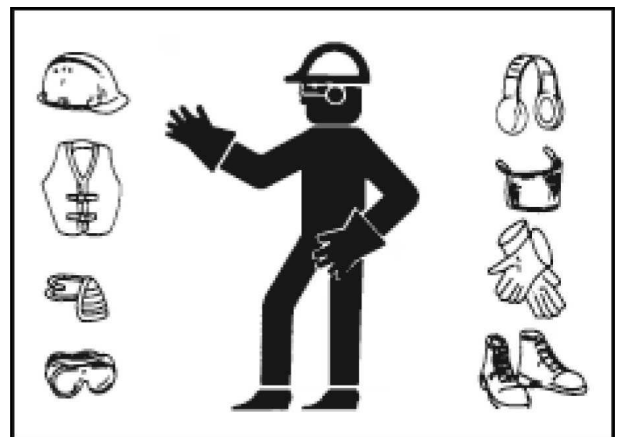

Fig. 5

1.4.3 Use the safety devices and protection available

Keep all guards in place and properly secured. Make sure that all guards and covers are properly installed, as specified, and in good condition. To help keep you and others safe, your tractor should be equipped with:

- Safety belt.
- PTO shield.

Depending on the type of operation, your tractor may also need:

- Rear-view mirror.
- Fire extinguisher.
- Warning triangle, guards, back-up alarm, lighting and additional safety decals

It is very important to know how to use the tractor's safety devices. Make sure that they are in place and in good condition. Do not remove or unplug any safety device.

1.4.4 Check the equipment

Before you begin the working day, take time to inspect your tractor and ensure that all systems are in good operating condition.

- Do not smoke when refilling the tractor. Keep away from open flame.
- Shut off the engine and wait for it to cool before refilling the tractor.
- Check for damaged, broken, loose or missing parts. Always keep the parts in good condition. Make sure that all guards and covers are in place.
- Check the safety belt for damage. If the belt is damaged, it must be replaced.



Fig. 7

- Make sure that the implements and accessories are properly installed and that the rotation of the tractor PTO and the implement are in agreement.
- Check the tire pressure and condition (absence of cuts and bulges). Replace damaged or worn tires. Make sure that the parking brake and pedal are functioning properly. Adjust them if necessary.
- Check the oil level and add oil, if necessary.
- Make sure that the PTO shaft safety devices are locked. Perform all servicing procedures described in the Maintenance section of this Guide.
- Make sure that the PTO shield and shaft guards are in place and functioning properly.
- Check the hydraulic system of the implement and tractor. Repair or replace damaged or missing parts.



CAUTION:

The release of hydraulic fluid or diesel fuel under pressure can penetrate the skin and cause serious injuries, blindness or death. Fluid leaks, under pressure, may not be visible. Use a piece of cardboard or wood to find the leaks. Do not use your hands directly. Always wear protective goggles. If the fluid penetrates the skin, it must be surgically removed within a few hours by a doctor who is familiar with this type of procedure

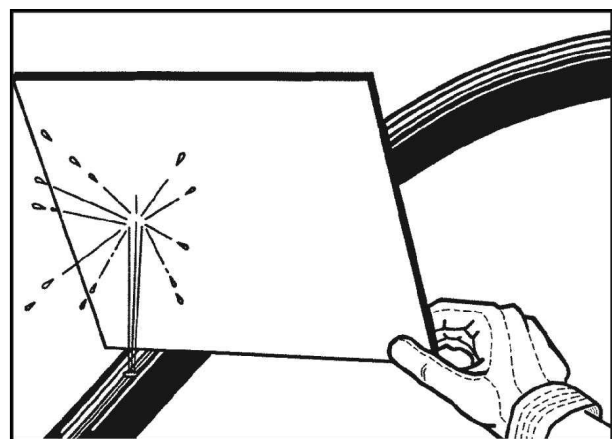

Fig. 8

Before applying pressure to the fuel or hydraulic system, make sure that all connections are tight and that all tubing, tubes and hoses are not damaged. Relieve all pressure before disconnecting the hydraulic or fuel tubing. Make sure that all the hydraulic tubing is correctly installed and uncrossed.



CAUTION:

The coolant systems accumulate pressure as the engine warms up. Before removing the radiator cap, shut down the engine and wait for the system to cool.

Check the engine cooling system and add coolant if necessary.

1.4.5 Cleaning the tractor

- Keep work surfaces and engine compartments clean.
 - Before cleaning the machine, always lower the implements to the ground, place the transmission in neutral, set the park brake, turn off the engine and remove the ignition key.
 - Clean the steps, pedals and operator's platform. Remove grease or oil. Clean any dust or mud. In winter, remove the snow or ice. Remember: Slippery surfaces are dangerous.
 - Remove and keep tools, chains or hooks.
-

1.4.6 Protect the environment

It is illegal to pollute sewers, streams and the ground. Waste must be sent to authorised sites, far from urban or conservation areas. In addition, dirty oil removed from the tractor must be stored in suitable containers before being disposed of. If in doubt, consult the local authorities.

1.5 Start-up

1.5.1 Prior to start-up



DANGER:

Operation of the engine Exhaust gases can cause asphyxia. Only operate the engine with the tractor in a ventilated area, i.e., never in a closed environment

Before putting the engine into operation, refer to the servicing table and check the items listed in servicing every 10 hours or daily.

Proceed as follows:

- (1) Examine all systems in search of possible leaks.
- (2) Check the level of brake fluid.
- (3) Check the water level in the engine cooling system.
- (4) Check the condition and tension of the fan belts and the compressor belts.
- (5) Check the engine oil level.
- (6) Check the amount of fuel in the tanks.
- (7) Check the tightness of wheel lug nuts, the correct attachment of hose clamps, fittings, electrical connections and operation of the instrument panel.
- (8) Check that all tractor systems are suitable for the work to be performed. For example: Power take-off shaft (if it is type 1000/540), height and length of the draw bar, remote control, etc.
- (9) In addition to the adjustments on the tractor, you should know how to make the adjustments of the implement to be used. For these adjustments, you should refer to the Manual for the use of the implement.

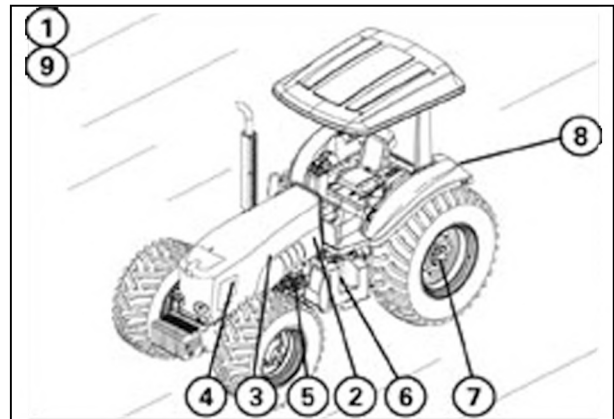

Fig. 9

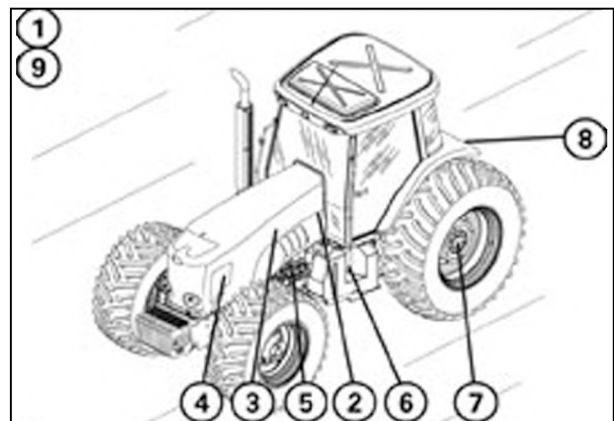

Fig. 10

Always fill the tractor fuel tank(s) after each day of work. Keeping the tank full prevents air from condensing inside of it overnight and transforming into water, which mixed with the fuel is highly damaging to the injection system.

NOTE: If the tractor has remained stationary for a long period, bleeding the fuel system is recommended. Engage the manual pump to drain water and impurities from the fuel system.

1.5.2 How to mount and dismount the machine safely

NOTE:

Do not use the control levers as a handgrip and never step on the pedal controls when mounting or dismounting the machine.

NOTE:

Do not attempt to mount or dismount when the tractor is in motion.

NOTE:

Do not jump off the tractor unless it is an emergency.

Before starting the procedure

Always use "three-point contact" with the machine and face it when mounting. Three-point contact means both hands and one foot or one hand and both feet in contact with the machine at all times during mounting and dismounting.

Clean your shoes and wash and dry your hands before mounting the machine. Use the handrail.

Procedure

1. Hold onto the handgrips.
2. Always use the ladder or steps when mounting or dismounting the machine.

1.5.3 Safe start-up



CAUTION:

Before starting the engine, make sure that there is enough ventilation. Engine smoke can cause asphyxia. Do not run the engine in closed environments.

Always start the engine from the operator's seat with all transmission levers in neutral and the PTO lever in neutral.

The power take-off should always be disengaged while starting the engine (mechanical PTO drive lever in the disengaged position), especially when the tractor is coupled to agricultural implements via the power take-off shaft; this prevents the engine from being subjected to an overload that may require an above necessary starting current and, as a result, burn out or reduce the useful life of the starter motor or regularly blow the starter circuit protection fuse.

Please remember that starting the engine with the PTO engaged and with an implement coupled to the power take-off shaft may cause accidents by the inadvertent actioning thereof.

The non-application of this recommendation is an operating fault and, therefore, any damage caused to the starter motor or the fuse will not be covered by normal warranty procedure.

Make sure that the tractor brake pedals are always joined by the union lock, except during maneuvers in the field that require independent use of the brakes. Make sure that the brakes are properly adjusted, so that both brakes are activated at the same time.

Adjust the seat, place the safety belt, engage the park brake and place all controls in neutral before starting the engine.



DANGER:

Start the engine with the start-up key and always seated in the operator's seat. Never attempt to start the engine by jumper cable.

The machine will start in gear if the safety switch circuit is bypassed. This can cause serious injuries or death if someone is near the tractor.

Follow the start-up procedures recommended in the Operation section of this Maintenance Guide. Such procedures include normal start-up, cold start and the use of start-up fluids.



Fig. 11

1.5.4 Test the controls

After starting the machine, re-check all gauges and lights. Make sure everything is working properly. If the tractor does not respond properly when each control is engaged, do not use the machine until the issue is resolved. Make sure that the cover of the engine starter solenoid is always in place.

1.5.5 Starting fluid

NOTE:

It is very important that you read and follow all instructions contained on the ether can before installing the ether-based cold start aid on the tractor.

Do not use starting aid fluids in aerosol containers on tractors equipped with a pre-heating system connected to the electrical system. The ether combined with the pre-heating system may cause explosions, damaging the engine, causing injuries to the handler, or both.

Handle start-up fluid properly. Start-up fluid should be used only when the ether-based starting aid is used as original factory equipment or when installed as an accessory by the dealer.

In the case of tractors equipped with glow plugs or a pre-heating system, this equipment must be removed before the installation of an ether-based start-up device.

If aerosol cans containing start-up fluid or the ether-based starting aid device are to be used, the pre-heating system must be disconnected. Remove the cable from the pre-heating system unit, which will be found in the intake manifold. Use insulating tape on the end of the cable to prevent short-circuit.



Fig. 12

1.6 Safe operation

1.6.1 Manoeuvre correctly

Make sure that the tractor is ready for the work to be performed. Know its nominal load capacities and never exceed these numbers. Make sure that the equipment or implements used do not exceed the load capacity of your tractor. Make sure that the PTO of the tractor and of the implement are compatible.

Remember that the tractors typically operate on uneven surfaces, not paved or uneven terrain. Operating conditions can reduce the amount of weight that you can load or tow.

1.6.2 Safety practices

- Operate the controls with care. Do not turn the steering wheel or use sudden movements to activate other controls.
- Do not mount or dismount the tractor when it is moving. Hold the steering wheel firmly and with both hands.
- Make sure that there is enough space in all directions, for both the tractor and the implement.
- Do not play with the tractor or equipment. These should be used for the indicated purpose only.
- Do not try to operate the controls if you are not in the operator's seat.
- Before dismounting, always disengage the PTO, lower all attachments and implements to the ground, put the tractor in neutral, engage the park brake, shut down the engine and remove the ignition key.

NOTE: Do not touch, lean on or try to reach the implement mechanisms, or allow others to do so.

ATTENTION: If any part of the equipment breaks, comes loose or breaks down, stop working, lower the equipment to ground level, shut down the engine, inspect the machine and make the necessary repairs or adjustments before restarting the operation.

Take care with pedestrians

Always be aware of what is happening around you. Do not allow untrained or unqualified personnel to operate the tractor. They can cause serious accidents.

Do not let other people walk on the implement or other equipment, such as trailers, with the exception of some harvesting equipment, which is specially designed for passengers during harvesting operations (not during transport). You must have space in such equipment, so that this type of transport can be carried out in complete safety. Do not allow children on the tractor.



Fig. 13

- Make sure that you can control both the speed and the direction of the machine before you put it in motion. Move the machine slowly until you are sure that everything is working as it should. After start-up, check the steering again — to the right and to the left. Make sure that you can move the machine, both to the right and to the left, and that you have full control of the brakes. If the differential is locked, do not operate at high speed or maneuver the tractor until the differential lock is unlocked.
- Do not lift objects that do not fit in the bucket. Purchase the correct equipment.
- Do not lift loads above other people.

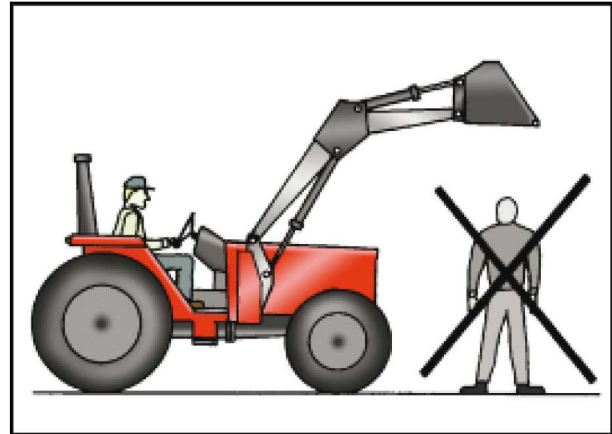

Fig. 14

- Keep people away from the operation site. Do not let other people remain under or pass beneath a raised implement.
- If a loader is being used, avoid abrupt stops, starts or maneuvers, or sudden changes of direction. Keep loads close to the ground during transport.
- Never stop (or let others stop) in front, underneath or behind equipment that is loaded or being loaded. Do not drive the tractor in the direction of someone who is stationary in front of a fixed object.
- Keep people away from the universal joints, hitches, drawbar, lift arms, PTO drives, cylinders, belts, pulleys and other moving parts. Keep all safeguards in place.
- Do not stand, or let others stand, between the tractor and the implement, unless the engine is switched off and the park brake is engaged, transmission is in neutral and all accessories are lowered to ground level.

1.6.3 Rollover risk

For tractors equipped with ROPS, hold the steering wheel firmly and do not leave the operator's seat until the tractor has stopped completely. If the cab doors are obstructed, exit the tractor through the rear window or through the roof hatch.

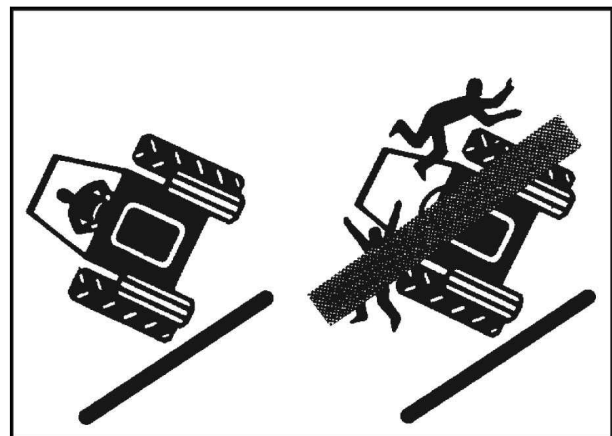

Fig. 15

Do not operate near ditches or sand banks. The distance from the obstacle must be equal to or greater than the total height of the obstacle in question

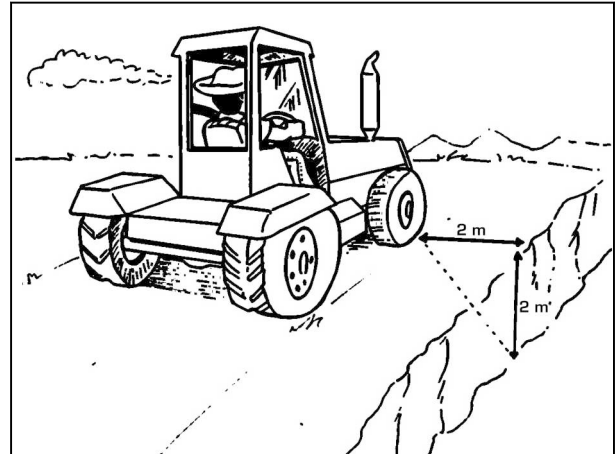

Fig. 16

1.6.4 To prevent rear rollover

Couplings on the rear axle or any other point above the swinging draw bar can cause rear rollovers.

- Do not transport any implement or attachment using the 3-point arm or any point on the rear axle or above. Only use the draw bar approved by Valtra and use a correctly sized pin to lock the bar in place.
- Couplings in high positions can cause rear rollover, which can result in a serious accidents or death. Attach loads to the drawbar only.
- Use only draw bars with a 3-point hitch when fasteners are used to keep the load in the lowered position.
- Use front counterbalance weights to improve the stability of the tractor when transporting heavy loads or to counterbalance the weight of a heavy implement transported by the rear of the tractor.
- Start to move the tractor slowly and gradually increase the speed. Do not engage in reverse or release the clutch quickly. If the tractor is coupled to a heavy load or a stationary object, incorrect use of the clutch may cause rollover.
- If the front end of the tractor begins to lift up, reduce speed and, if necessary, release the clutch.
- If the tractor becomes stuck in mud or snow, do not try to move, because the rear wheels may slip and the tractor may roll over. Lift any coupled implement and try to reverse. If this is not possible, tow it using another vehicle.
- If you get stuck in a ditch, try to get out in reverse, if possible. If you need to get out from the front, do so slowly and carefully.
- Tractors without implements or with implements coupled to the rear should be operated and should go down slopes in a forwards direction.
- Tractors with front loaders should be operated and should ascend slopes in a forward direction. Keep the loader as close to the ground as possible.
- Always keep the tractor engaged when going down slopes. Do not go down slopes with the clutch disengaged and the transmission in neutral.

1.6.5 To prevent side rollovers

- Adjust the wheel track to the widest setting, which is the most appropriate for the work being performed.
- Lock the brake pedals with the union lock before using transport speeds.
- Reduce speed until appropriate for the operating conditions. If the tractor is equipped with a front loader, load the bucket and the load at the lowest possible level.
- Make wide turns and use low speeds. Avoid jerking or you may lose control of the steering wheel.
- Do not transport loads that are very heavy for the tractor's capacity, because the load can fall off the tractor and fall down the hill, or the tractor may slip and collide with the load being towed.
- Do not brake suddenly. Apply the brakes gently and gradually.

This as a preview PDF file from best-manuals.com



Download full PDF manual at best-manuals.com