

*Challenger*

# Operator Manual

---

**MT745C / MT755C / MT765C**  
**Rubber Track Tractor - CE**

---

S/N: EFF...Uxx1001

# Challenger<sup>®</sup>

## TO OUR CUSTOMER:

*Congratulations on your selection of a Challenger<sup>®</sup> Product. We believe you have exercised excellent judgment in the purchase of your Challenger<sup>®</sup> machine. We are most appreciative of your patronage.*

*Your Dealer has performed the pre-delivery service on your new machine.*

*He will discuss with you the operating and maintenance instructions given in this manual, and instruct you in the proper and varied applications of this machine. Call on him at any time when you have a question or need equipment related to the use of your machine.*

*We recommend that you carefully read this entire manual before operating the unit. Also, time spent in becoming fully acquainted with its performance features, adjustments, and maintenance schedules will be repaid in a long and satisfactory life of the product.*

*This equipment is covered by a written warranty which will be provided to you by your Challenger<sup>®</sup> Dealer at time of purchase.*

AGCO<sup>®</sup> reserves the right to make changes or add improvements to its products at any time without incurring any obligation to make such changes to products manufactured previously. AGCO<sup>®</sup>, or its dealers, accept no responsibility for variations which may be evident in the actual specifications of its products and the statements and descriptions contained in this publication.

*Challenger<sup>®</sup> is a worldwide brand of AGCO Corporation, Duluth, Georgia*

### **CALIFORNIA Proposition 65 Warning**

**WARNING:** Diesel engine exhaust and some of its constituents are known to the State of California to cause cancer, birth defects, and other reproductive harm.

**WARNING:** Battery posts, terminals and related accessories contain lead and lead compounds, chemicals known to the State of California to cause cancer, birth defects, and other reproductive harm. Wash hands after handling.

---

**CHALLENGER®  
MT745C / MT755C / MT765C  
521969D1 K Rev  
CONTENTS**

SAFETY ..... A-1

GENERAL INFORMATION ..... B-1

OPERATION ..... C-1

ADJUSTMENTS ..... D-1

LUBRICATION AND MAINTENANCE ..... E-1

TROUBLESHOOTING ..... F-1

SPECIFICATIONS ..... G-1

ACCESSORIES AND OPTIONS ..... H-1

DELIVERY CHECKLIST ..... I-1

INDEX ..... J-1

# CONTENTS

---

---

# SAFETY

## Contents

Safety Alert Symbol .....	A-3
Safety Messages .....	A-3
Informational Messages .....	A-3
Safety Signs .....	A-4
Safety Sign Location .....	A-4
General .....	A-4
Important Safety Information .....	A-4
General Hazard Information .....	A-5
Pressurized Air .....	A-5
Asbestos Information .....	A-5
Electrical Storm Injury Prevention .....	A-5
Before Starting Engine .....	A-5
Mounting and Dismounting .....	A-6
Engine Starting .....	A-7
Before Operation .....	A-7
Operation .....	A-7
Parking .....	A-8
Operator Station .....	A-8
Crushing Prevention and Cutting Prevention .....	A-8
Rollover Protective Structure (ROPS) .....	A-8
Burn Prevention .....	A-9
Coolant .....	A-9
Oils .....	A-9
Lines, Tubes and Hoses .....	A-9
Fluid Penetration .....	A-10
Batteries .....	A-10
Fire And Explosion Prevention .....	A-11
Fire Extinguisher .....	A-12
Safety Signs And Labels .....	A-13
Side View .....	A-14
Front View .....	A-17
Rear View .....	A-19



## SAFETY ALERT SYMBOL

**FIG. 1:** The safety alert symbol means ATTENTION! BECOME ALERT! YOUR SAFETY IS INVOLVED!

Look for the safety alert symbol both in this manual and on safety signs on this machine. The safety alert symbol will direct your attention to information that involves your safety and the safety of others.



**FIG. 1**

## SAFETY MESSAGES

The words DANGER, WARNING or CAUTION are used with the safety alert symbol. Learn to recognize these safety alerts and follow the recommended precautions and safety practices.



**DANGER:** Indicates an imminently hazardous situation that, if not avoided, will result in DEATH OR VERY SERIOUS INJURY.



**WARNING:** Indicates a potentially hazardous situation that, if not avoided, could result in DEATH OR SERIOUS INJURY.



**CAUTION:** Indicates a potentially hazardous situation that, if not avoided, may result in MINOR INJURY.

## INFORMATIONAL MESSAGES

The words IMPORTANT and NOTE are not related to personal safety, but are used to give additional information and tips for operating or servicing this equipment.

*IMPORTANT: Identifies special instructions or procedures which, if not strictly observed, could result in damage to or destruction of the machine, process, or its surroundings.*

*NOTE: Identifies points of particular interest for more efficient and convenient repair or operation.*

# SAFETY

---

## SAFETY SIGNS



**WARNING: DO NOT remove or obscure safety signs. Replace any safety signs that are not readable or are missing. Replacement signs are available from your dealer in the event of loss or damage. The actual location of the safety signs is illustrated at the end of this section.**

If a used machine has been purchased, make sure all safety signs are in the correct location and can be read.

See Safety Sign Location of this section for illustrations.

Replace any safety signs that can not be read or are missing. Replacement safety signs are available from your dealer.

## SAFETY SIGN LOCATION

### General

The following safety signs are installed to alert operators to hazards in specific machine areas. The signs are for personal safety. **READ AND UNDERSTAND THE SIGNS!**

Keep signs clean by wiping off regularly. Use a cleaning solution if necessary.

Replace signs if missing, damaged or painted.

If a used machine has been purchased, make sure that all the safety signs are in the correct place and are readable.

Clean machine surface thoroughly with a cleaning solution before replacing signs.

## IMPORTANT SAFETY INFORMATION

Most personal injuries occurring during machine operation, maintenance or repair are caused by failure to observe basic safety rules and precautions. In most cases, an injury can be avoided by recognizing hazardous situations before an injury occurs.

Operator must be alert to potential hazards and have the necessary training, skills and tools to perform these functions properly.

Improper operation, lubrication, maintenance or repair of this machine can be hazardous and could result in injury or death.

Do not operate or perform any lubrication, maintenance or repair on this machine, until reading and understanding operation, lubrication, maintenance and repair information.

Safety precautions and warnings are provided in this manual and on machine. If these hazard warnings are not heeded, bodily injury or death could occur to operator or bystanders.

Not every possible circumstance involving a potential hazard can be anticipated. The warnings in this publication and on machine are not all inclusive. If using tool procedure, work method or operating technique not specifically recommended, be satisfied it is safe.

Make sure machine will not be damaged or be made unsafe by operation, lubrication, maintenance or repair procedures chosen. Information, specifications, and illustrations in this publication are based on information available at the time of publication.

Specifications, torques, pressures, measurements, adjustments, illustrations, and other items can change at any time. These changes can affect the service given to machine. Obtain complete and most current information before starting any job. Dealers have the most current information available.



**WARNING: When replacement parts are required for this machine AGCO recommends using AGCO replacement parts or parts with equivalent specifications including, but not limited to, physical dimensions, type, strength and material. Failure to heed this warning can lead to premature failures, machine damage, personal injury or death.**



---

## **GENERAL HAZARD INFORMATION**

When engine is running and steering wheel is turned, machine will turn with transmission control lever in park position.

Do not start engine until area is free of personnel to avoid personal injury due to unexpected machine movement.

Know width of your equipment to maintain proper clearance when operating machine near fences or boundary obstacles.

Wear a hard hat, protective glasses, and other protective equipment as required.

Do not wear loose clothing or jewelry that can snag on controls or on other parts of machine.

Make sure all protective guards and covers are secured in place on machine.

Keep machine free from foreign material. Remove debris, oil, tools, and other items from deck, walkways, and steps.

Secure lunch boxes, tools, and other loose items not a part of machine.

Know appropriate work site hand signals and personnel authorized to give the hand signals. Accept hand signals from one person only.

Do not smoke when refueling machine.

Do not refuel machine unless engine is stopped and allowed to cool. If engine components are still hot, do not leave fuel filter nozzle unattended and avoid fuel spills.

Never put maintenance fluids into glass containers. Drain all liquids into a suitable container.

Discard any drained fluids and discard any filter elements according to local regulations.

Use all cleaning solutions with care.

Report all necessary repairs.

Do not allow unauthorized or untrained personnel on machine.

Do not smoke when servicing an air conditioner or whenever refrigerant gas may be present. Inhaling fumes released from a flame contacting air conditioner refrigerant can cause bodily harm or death.

Inhaling gas from air conditioner refrigerant through a lit cigarette can cause bodily harm or death.

Unless instructed otherwise, perform maintenance under the following conditions:

- Machine is parked on level ground. Implements are lowered to the ground.
- Transmission control lever is in park position.
- Engine is stopped.
- Engine start switch is turned off and the switch key is removed.
- Machine has cooled down.

## **Pressurized Air**

Air under pressure can cause personal injury. When pressurized air is used for cleaning, wear a protective face shield, protective clothing and protective shoes.

Maximum air pressure for cleaning purposes must be below 205 kPa (30 psi).

## **Asbestos Information**

AGCO equipment and replacement parts shipped from AGCO are asbestos free. AGCO recommends use of only genuine AGCO replacement parts.

## **Electrical Storm Injury Prevention**

When lightning is striking in vicinity of machine, operator should not attempt to dismount or mount machine.

If in operator's station during an electrical storm, stay in operator's station. If on ground during an electrical storm, stay away from machine.

## **Before Starting Engine**

Start engine only from operator compartment. Never short across starter terminals or batteries. Shorting could damage electrical system or cause unexpected machine movement.

Adjust seat so full pedal travel can be achieved with operator's back against seat back.

Make sure machine is equipped with a lighting system adequate for job conditions. Make sure all machine lights are working properly.

Before starting engine or moving machine, make sure no one is under, around or on machine. Make sure area is free of personnel.

# SAFETY

## Mounting and Dismounting

**FIG. 2:** Mount and dismount machine only at locations with steps and/or handholds (1). Before mounting machine, clean steps and handholds. Inspect stairs and handholds. Make any necessary repairs.

Face ladder whenever mounting or dismounting machine.

Maintain three-point contact with the steps and handholds. Three-point contact is two feet and one hand or one foot and two hands.

Never mount or dismount a moving machine. Never jump off machine except in an emergency.

Do not carry tools or supplies when mounting or dismounting machine. Use a hand line to pull equipment onto platform.

Do not use any controls as handholds when entering or exiting operator compartment.

**IMPORTANT:** Make sure steps are not adjusted too close to hood on machine.

You must leave a minimum dimension of 75 mm (3 in) between inside handhold and hood so there is enough room for operator's hand.

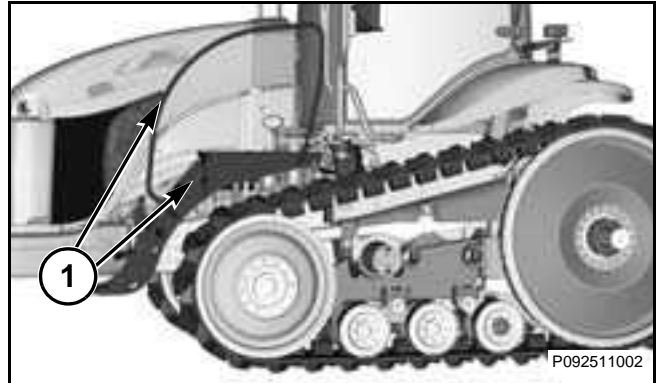

**FIG. 2**

## Engine Starting

Move all hydraulic controls to hold position before starting engine.

Make sure transmission control lever is in park position.

Diesel engine exhaust contains products of combustion which can be harmful. Always run engine in a well ventilated area. If in an enclosed area, vent exhaust to outside.



**WARNING: Machine WILL turn if steering wheel is moved when transmission control lever is in NEUTRAL or PARK and engine is running.**

Do not start engine until area is free of personnel to avoid personal injury due to unexpected machine movement.

## Before Operation

Clear all personnel from machine and area.

Clear all obstacles from machine's path. Beware of hazards (wires, ditches, etc).

Be sure all windows are clean and secured in shut position.

Adjust rearview mirrors for best visibility close to machine. Make sure horn, backup alarm (if equipped) and all other warning devices are working properly.

On drawbar-towed implements, attach a transport chain of sufficient capacity between machine drawbar support and implement. Provide only enough slack in chain to permit turning.

Fasten seat belt securely, low around hips. Only one passenger/instructor should be allowed to ride in machine cab, and must be seated in instructor seat and have seat belt fastened.

## Operation

Only operate machine while in operator's seat. Seat belt must be fastened while operating machine. Only operate controls while engine is running.

Check for proper operation of all controls and protective devices while operating machine slowly in an open area.

Make sure no one will be endangered before moving machine.

Report any damage noted during operation of machine. Make any necessary repairs.

Hold attachments approximately 40 cm (16 in) above ground level while driving machine. Do not drive machine near an overhang, near edge of a cliff, or near edge of an excavation.

If machine begins to sideslip on a grade, immediately dispose of load and turn machine downhill.

Be careful to avoid any ground condition which could cause machine to tip.

A rollover of machine can occur when working on hills, banks, or slopes. A rollover of machine can also occur when crossing ditches, ridges, or other unexpected obstacles.

When possible, operate machine up slopes and down slopes. Avoid operating machine across slope, when possible.

Keep machine under control. Do not overload machine beyond capacity.

Make sure towing devices are adequate for application.

Make sure components on three-point hitch are adequate for application.

Connect trailing equipment only to a drawbar or hitch.

Never straddle, or allow other personnel, to straddle a wire cable.

When maneuvering to connect equipment, make sure no personnel are between machine and trailing equipment. Block up hitch of trailing equipment to align equipment with drawbar.

Know maximum dimensions of machine.

When operating on icy roads, reduce travel speed.

After operating in muddy conditions, allow sufficient time for belts to reject debris and moisture before making high speed maneuvers. Belts that are wet and belts that are muddy may impede machine's steering.

If stability of machine is noticeably reduced, reduce travel speed.

Select a gear that controls machine speed when descending a hill.

Downshift if braking is required to control machine speed. Never coast down a hill with transmission in neutral.

Do not steer machine when you cross ditches. Ditches that are wide and/or ditches that are deep may allow guide blocks to sag below midwheels. This can cause belt to come off.

Do not allow passengers anywhere on machine except on an approved passenger seat. Passengers must have passenger seatbelt securely fastened during any operation.

# SAFETY

---

## Parking

Park on a level surface. If machine must be parked on a grade, chock machine's wheels.

Move transmission control lever to park position.

Lower all implements to ground.

Move implement controls to hold position.

Before stopping engine, move throttle control lever to low idle position. Run engine at low idle speed for five minutes to allow turbocharger to cool or use optional delayed engine shutdown.

Stop engine.

Turn engine start switch to off position and remove engine start switch key.

Turn battery disconnect switch to off position.

## Operator Station

Any modifications to inside of operator station should not project into operator space. The addition of a radio, fire extinguisher and other equipment must be installed so defined operator space is maintained.

Any item brought into cab should not project into defined operator space. A lunch box or other loose items must be secured. Objects must not pose an impact hazard in rough terrain or in event of a rollover.

## Crushing Prevention and Cutting Prevention

Support equipment properly when performing work under equipment. Do not depend on hydraulic cylinders to hold equipment. An implement can fall if a control lever is moved or if a hydraulic line breaks.

Never jump across starter solenoid terminals to start machine. Unexpected machine movement could result.

Never attempt adjustments while machine is moving or engine is running.

Whenever there are attachment control linkages, clearance in linkage area will change with movement of attachment.

Stay clear of all rotating parts and moving parts.

Keep objects away from moving fan blades. Fan blades will throw objects and can cut objects.

Do not use a wire cable kinked or frayed. Wear gloves when handling wire cable.

Loose retainer pins can injure personnel. Make sure there are no people in area when striking a retainer pin. To avoid injury to your eyes, wear protective glasses when striking a retainer pin.

Chips or other debris may fly off objects when striking objects. Make sure no one will be injured by flying debris before striking any object.

## Rollover Protective Structure (ROPS)

Do not make any modifications to ROPS as this will affect protection provided. Do not alter structure by welding, cutting, adding weight, or drilling holes into structure.

Any alteration not specifically authorized by AGCO invalidates AGCO certification for ROPS. The protection offered by ROPS will be impaired if ROPS has structural damage or alteration. Damage to structure can be caused by an overturn or by falling objects.

Do not mount items (fire extinguishers, first aid kits, work lights, etc) by welding brackets or drilling holes in ROPS. See dealer for mounting guidelines.

## BURN PREVENTION

**FIG. 3:** Do not touch any part of an operating engine. Other components such as transmission, axles and oil reservoir may also be hot. Allow engine to cool before any maintenance is performed on engine. Relieve all pressure in air, oil, lubrication, fuel and cooling systems before any line fittings or related items are disconnected.



**FIG. 3**

## Coolant

**FIG. 4:** When engine is at operating temperature, engine coolant is hot. The coolant is also under pressure. Radiator and all lines to heaters or to engine contain hot coolant.

Any contact with hot coolant or with steam can cause severe burns. Allow cooling system components to cool before cooling system is drained.

Check coolant level only after engine has been stopped.

Ensure filler cap is cool before removing. Filler cap must be cool enough to touch with a bare hand. Remove filler cap slowly to relieve pressure.

Cooling system conditioner contains alkali. Alkali can cause personal injury.

Do not allow alkali to contact skin, eyes, or mouth.

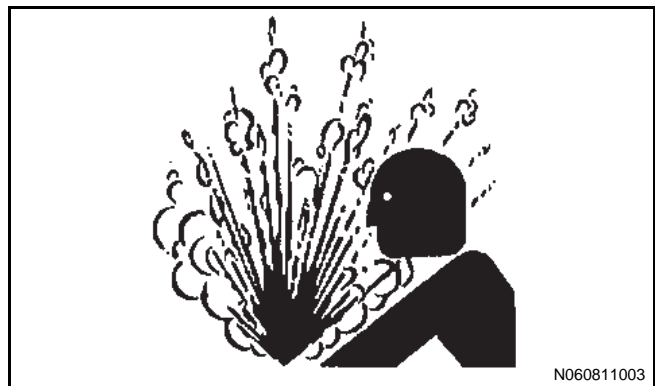

**FIG. 4**

## Oils

Hot oil and hot components can cause personal injury. Do not allow hot oil to contact skin. Do not allow hot components to contact skin.

Remove hydraulic tank filler cap only after engine has been stopped.

Filler cap must be cool enough to touch with a bare hand. Follow the standard procedure in this manual to remove hydraulic tank and transmission filler caps.

## Lines, Tubes and Hoses

Do not bend or strike high pressure lines. Do not install any lines bent or damaged.

Repair any loose or damaged lines. Leaks can cause fires. Consult your dealer for repair or for replacement parts.



**DANGER:** Diesel fuel or hydraulic fluid under pressure can penetrate the skin or eyes and cause serious personal injury, blindness, or death.

# SAFETY

## Fluid Penetration

**FIG. 5:** Always use a board or cardboard when checking for a leak. Leaking fluid under pressure can penetrate body tissue. Fluid penetration can cause serious injury and possible death. A pin hole leak can cause severe injury. If fluid is injected into skin, get treatment immediately. Seek treatment from a doctor familiar with this type of injury.

Check lines, tubes and hoses carefully. Do not use your bare hand instead, use a board or cardboard to check for leaks. Tighten all connections to recommended torque.

Replace the parts if any of the following conditions are present:

- End fittings are damaged or leaking.
- Outer coverings are chafed or cut.
- Wires are exposed.
- Outer coverings are ballooning.
- Flexible part of hoses are kinked.
- Outer covers have embedded armoring.
- End fittings are displaced.

***IMPORTANT:** Care must be taken to ensure that fluids are contained during performance of inspection, maintenance, testing, adjusting, and repair of machine. Be prepared to collect the fluid with suitable containers before opening any compartment or disassembling any component containing fluids. Dispose of all fluids according to local regulations and mandates*

## Batteries

**FIG. 6:** Electrolyte is an acid. Electrolyte can cause personal injury. Do not allow electrolyte to contact skin or eyes. Always wear protective glasses for servicing batteries. Wash hands after touching batteries and connectors.

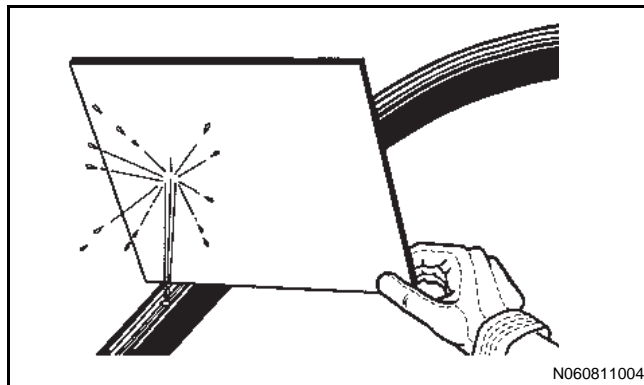

**FIG. 5**

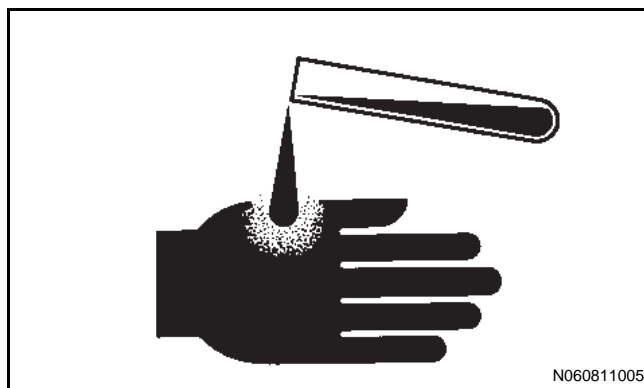

**FIG. 6**

**FIG. 7:** Gases from a battery can explode. Keep any open flames or sparks away from top of a battery. Do not smoke in battery charging areas.

Never check battery charge by placing a metal object across terminal posts. Use a voltmeter or a hydrometer.

Improper jumper cable connections can cause an explosion that can result in injury.

Do not charge a frozen battery. This may cause an explosion.



**FIG. 7**

## FIRE AND EXPLOSION PREVENTION

**FIG. 8:** All fuels, most lubricants, and some coolant mixtures are flammable.

Flammable fluids leaking or spilled onto hot surfaces or onto electrical components can cause a fire.

Fire may cause personal injury and property damage.

Remove all flammable materials such as fuel, oil, and debris from machine.

Do not allow any flammable materials to accumulate on machine.

Store fuels and lubricants in properly marked containers away from unauthorized persons. Store oily rags and any flammable materials in protective containers.

Do not smoke in areas used for storing flammable materials.

Do not operate machine near any flame.

Exhaust shields protect hot exhaust components from oil spray or fuel spray in case of a break in a line, hose, or in a seal. Exhaust shields must be installed correctly.

Do not weld on lines or tanks that contain flammable fluids. Do not flame cut lines or tanks containing flammable fluid. Clean any such lines or tanks thoroughly with a nonflammable solvent prior to welding or flame cutting.

Check all electrical wires daily. Repair any wires loose or frayed before operating machine. Clean and tighten all electrical connections.

Dust that is generated from repairing nonmetallic hoods or nonmetallic fenders can be flammable and/or explosive. Repair such components in a well ventilated area away from open flames or sparks.

Inspect all lines and hoses for wear or for deterioration.

Hoses must be properly routed. Lines and hoses must have adequate support and secure clamps. Tighten all connections to recommended torque.



**FIG. 8**

## SAFETY

**FIG. 9:** Use caution when refueling a machine. Do not smoke while refueling and do not refuel near open flames or sparks. Always stop engine before refueling. Fill fuel tank outdoors.



**FIG. 9**

### Fire Extinguisher

**FIG. 10:** Make sure that a fire extinguisher is available and be familiar with operation. Inspect and service fire extinguisher regularly, and obey recommendations on instruction plate.

An optional mounting bracket (1) can be installed on right front frame rail.

Bracket is designed to hold a 4.5 kg (10 lb) extinguisher.

Do not weld a bracket on cab ROPS frame to install fire extinguisher.

Do not drill holes in cab ROPS frame to mount fire extinguisher on the ROPS.

Make sure all clamps, guards, and heat shields are installed correctly to prevent vibration, rubbing, and excessive heat during operation.

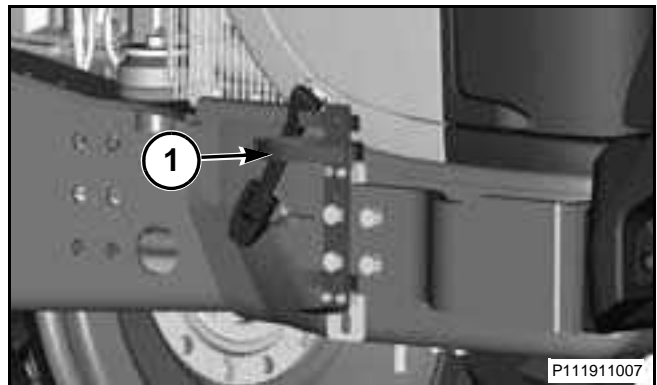

**FIG. 10**



**SAFETY SIGNS AND LABELS**

There are several specific safety signs on this machine. The exact location of the hazards and description of hazards are reviewed in this section.

Please become familiarized with all safety signs. Make sure all safety signs are legible. Clean safety signs or replace safety signs if you cannot read the words. Replace illustrations if not visible. When you clean safety signs, use a cloth, water, and soap. Do not use solvent, gasoline, or other harsh chemicals to clean safety signs. Solvents, gasoline, or harsh chemicals could loosen adhesive that secures safety sign. Loose adhesive will allow safety sign to fall.

Replace any safety sign damaged or missing. If a safety sign is attached to a part of machine that is replaced, install a safety sign on replacement part. Any AGCO dealer can provide new safety signs.



**WARNING: DO NOT remove or obscure Danger, Warning, Caution, or Instruction Signs.**

# SAFETY

## Side View

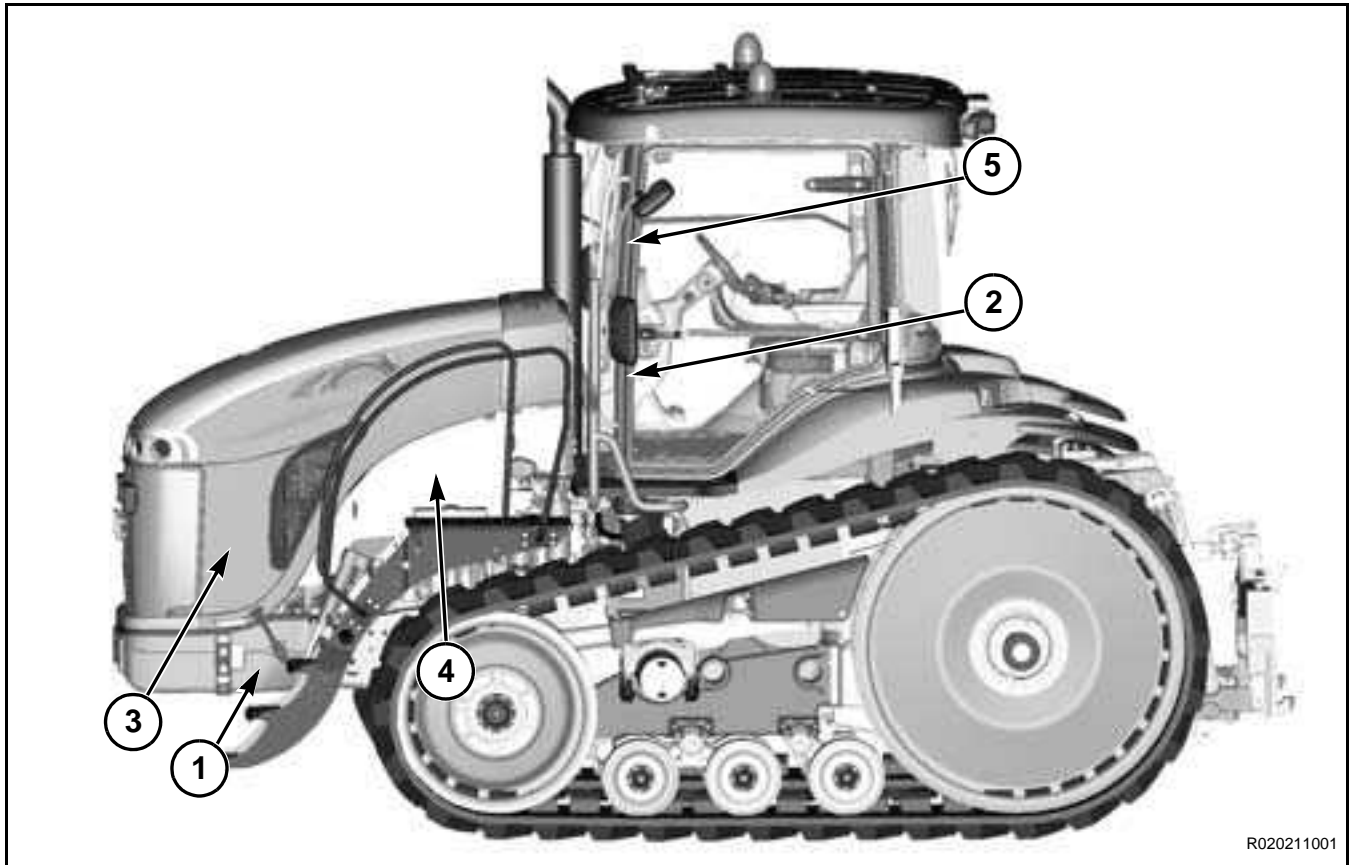

R020211001

FIG. 11

FIG. 11: Side View

FIG. 12: Warning - Radar Unit (1)

The safety sign is located on outside of frame rails on both sides.

Do not look directly into face of ground speed sensor while in operation. Eye injury may occur from low intensity microwave signal emitted.

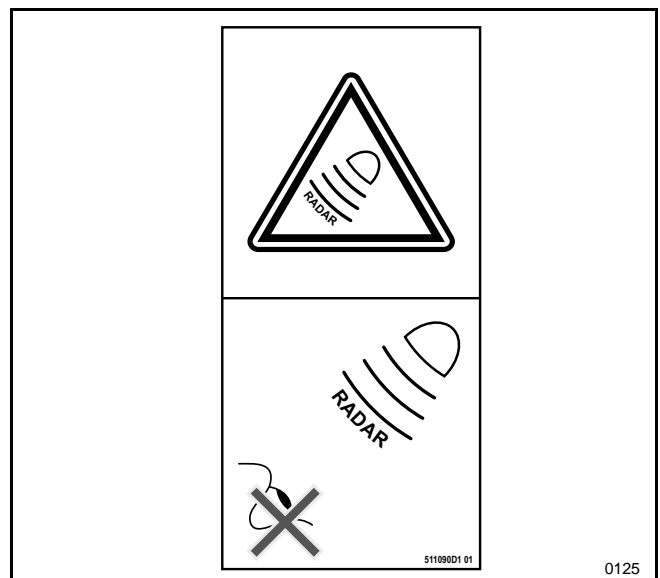
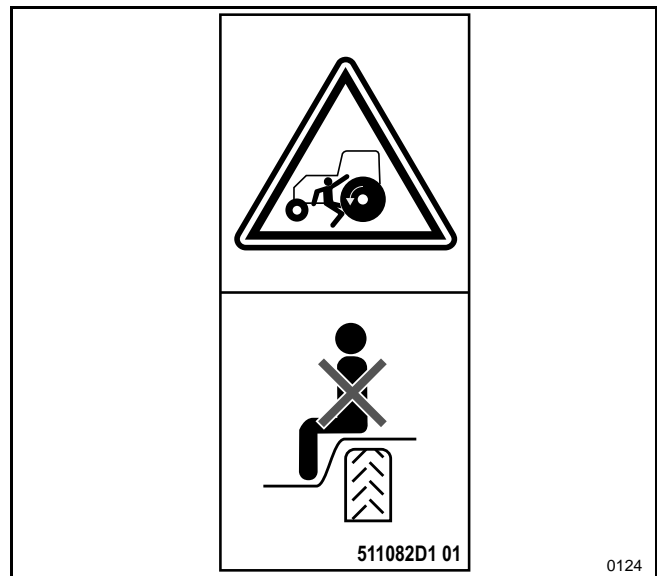

FIG. 12

**FIG. 13:** Warning - No Passengers (2)

The safety sign is located on left front post inside cab. Do not allow passengers anywhere on machine except on an approved passenger seat. Severe injury or death could result from a fall or from contact with moving components or machinery. Loss of control causing personal injury could occur if operator's view or access to controls is obstructed.

**FIG. 13**

**FIG. 14:** Warning - Rotating Blade Hazard - (3) - The safety sign is located on both sides under the front hood. Keep out of engine compartment while engine is running. Keep hands clear of fan while engine is running. Shut off engine and remove key before performing maintenance or repair work.

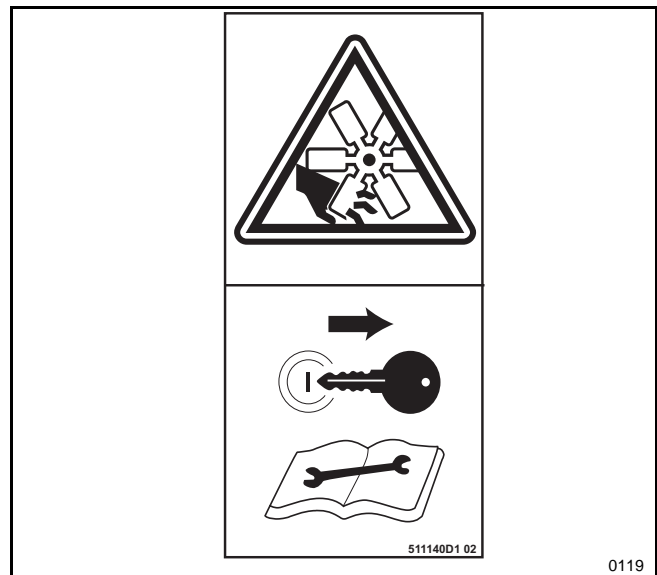
**FIG. 14**

**FIG. 15:** Warning - Electrical Shock Hazard (4) - Risk of personal injury and component damage.

The safety sign is located on both sides of fan shroud. Remove negative cable(s) from battery(s) before removing starter solenoid cover and before servicing electrical system.

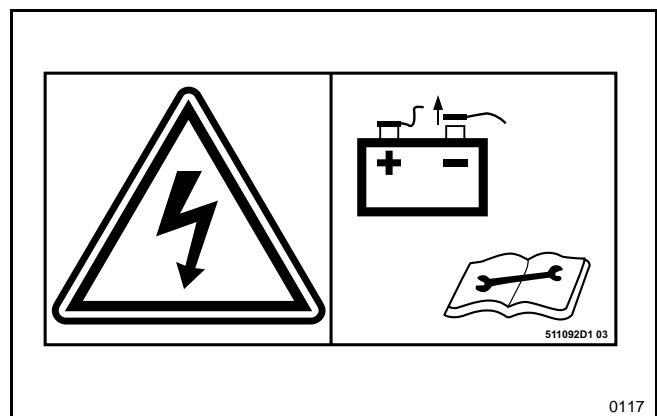
**FIG. 15**

## SAFETY

**FIG. 16:** Warning - Seatbelt sign is located inside the cab on the left side corner (5). Operators and passengers must have seatbelt securely fastened during any operation.



**FIG. 16**

## Front View

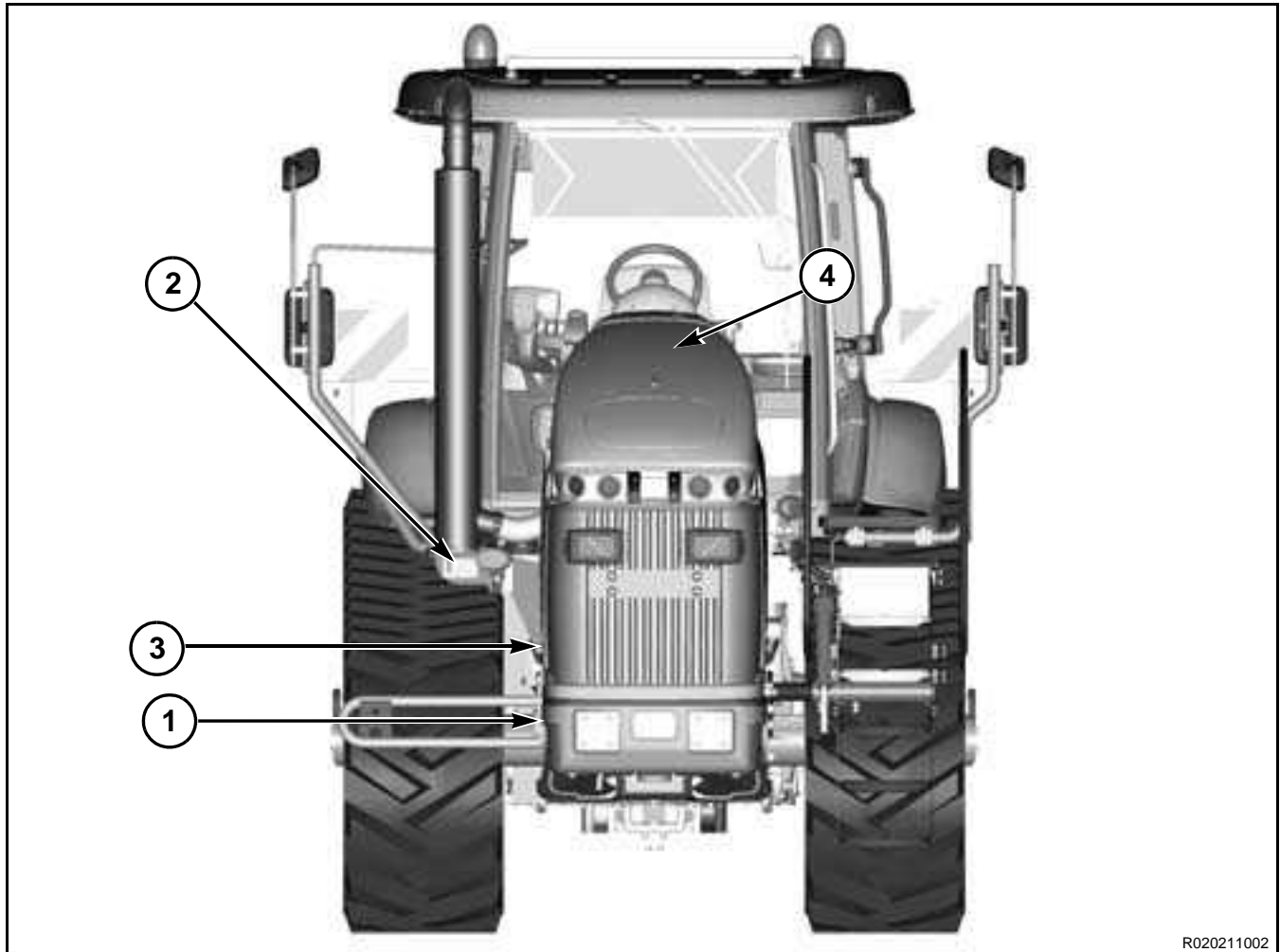

R020211002

FIG. 17

## FIG. 17: Front View

**FIG. 18:** Warning - Battery Explosion Hazard (1)

The safety sign is located on frame rail on right side of machine and on hold down bracket for batteries.

Improper jumper cable connections can cause explosion resulting in personal injury. When using jumper cables, always connect positive (+) cable, from external source, to positive (+) jump start post and negative (-) cable, from external source, to engine block or frame.

Remove negative cable (s) from battery(s) before removing starter solenoid cover and before servicing electrical system.

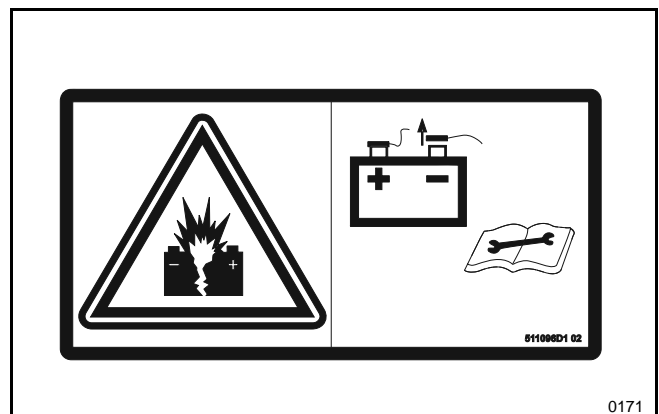

0171

FIG. 18

# SAFETY

**FIG. 19:** Warning - Hot Surface (2)

The safety sign is located under muffler on right side of machine.

Avoid contact with hot surfaces. Exhaust piping and engine components become hot during engine operation and cool slowly after engine shutdown. Any contact with hot surfaces can cause severe burns.

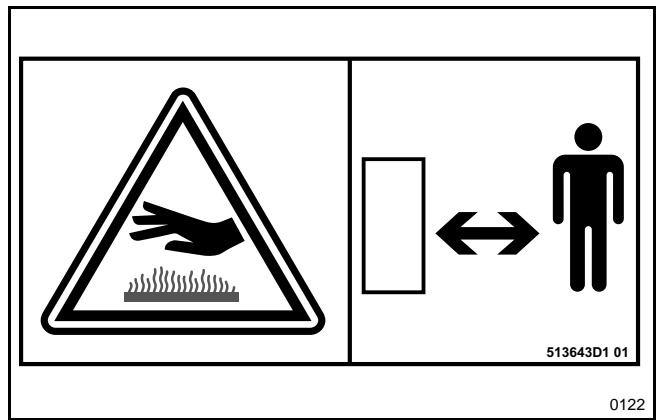
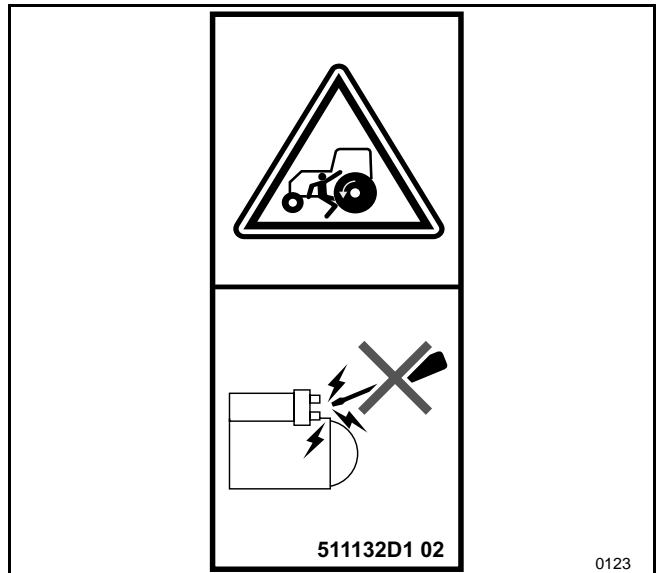

**FIG. 19**

**FIG. 20:** Danger - Starter Bypass (3)

The safety sign is located on starter motor on left and right side of machine.

Start engine from operator's seat only. Personal injury could result from inadvertent machine operation if neutral start switch or starter solenoid is bypassed.

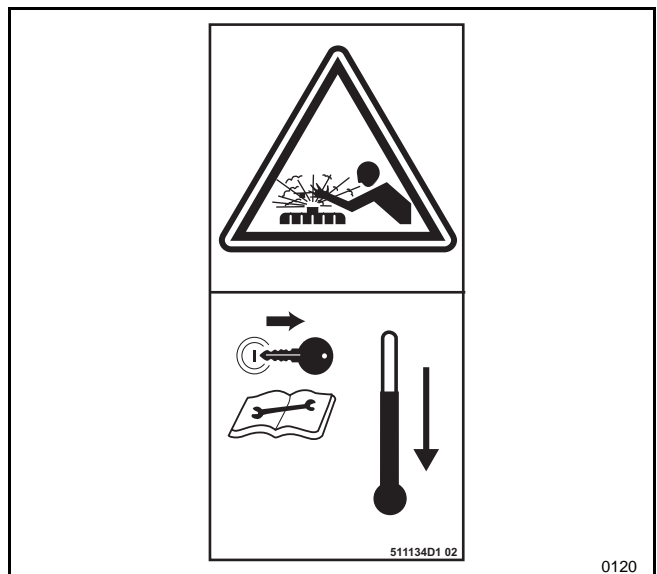

**FIG. 20**

**FIG. 21:** Warning - Hot Pressurized Coolant (4)

The safety sign is located underneath cover for expansion tank.

Pressurized System: Hot coolant can cause serious burns. To open cooling system filler cap, stop engine and wait until cooling system components are cool. Loosen cooling system pressure cap slowly to relieve pressure.



**FIG. 21**

## Rear View

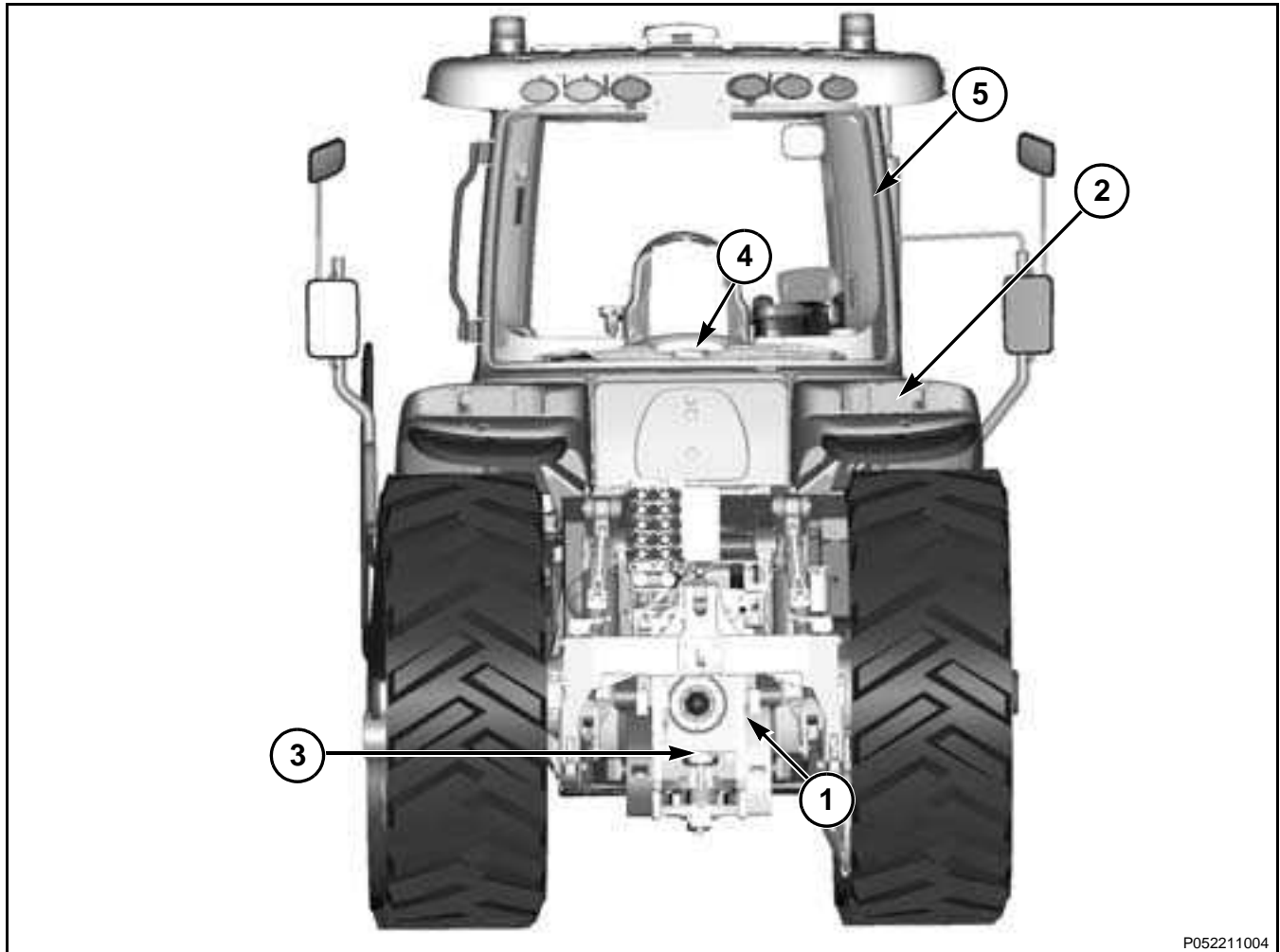

P052211004

FIG. 22

FIG. 22: Rear View

**FIG. 23: Danger Hazard - Power Take Off (1)**

The safety signs are located on each side of PTO shaft. To avoid personal injury due to entanglement with rotating shaft, keep PTO master cover and all power drive system covers in place. Install PTO shaft guard when system is not in use.

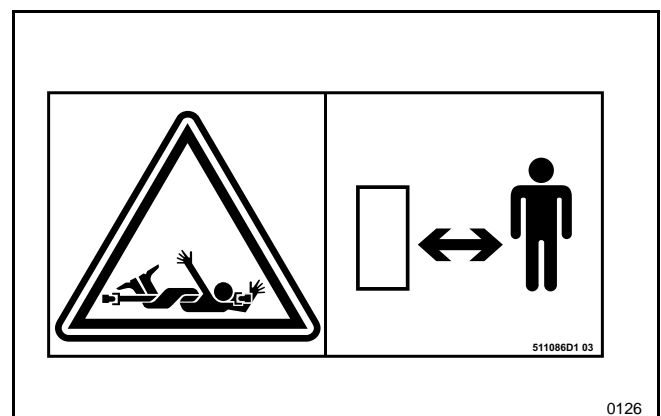

511086D1 03

0126

FIG. 23

## SAFETY

**FIG. 24:** Warning Hazard - Three Point Hitch Control (2). The safety sign is located on each rear fender of machine. Do not stand on or between implement and machine while any hitch controls are being operated. Stand away from implement and machine when any hitch control are being operated. Standing on or between implement and machine while hitch controls are operated may result in personal injury or death.



**FIG. 24**

**FIG. 25:** Danger - Rear Rollover (3). Safety sign is located on back of machine.

Pull only from drawbar. Pulling from any other point may cause a rollover.

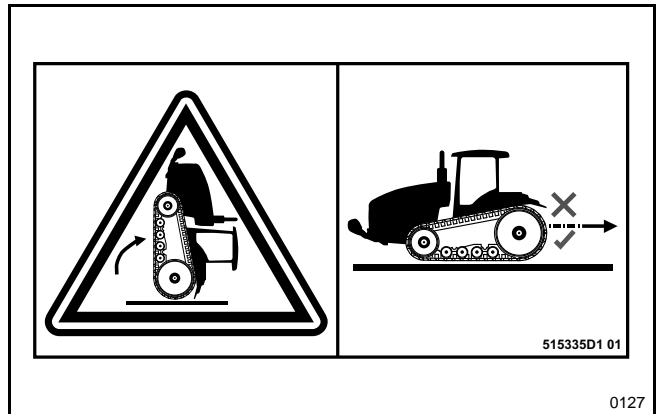

**FIG. 25**

**FIG. 26:** In case of emergency, use rear window as an alternate means of exit (4). Both strut supports must be disconnected from window before using as an exit.

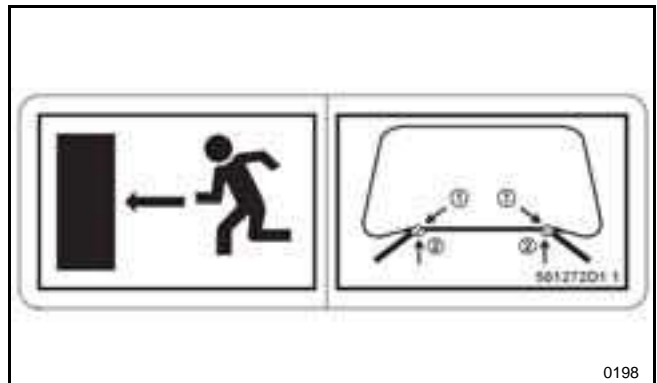

**FIG. 26**



**FIG. 27:** Warning - Operators Manual (5)

The safety sign is located on right rear post and rear power outlet panel inside cab.

Read and understand the operator and safety instructions in operator's manual and on machine. Locate and understand control operations.

Failure to follow safety and operational instructions can result in serious operator or bystander injury.

**FIG. 27**

**NOTES**

**GENERAL INFORMATION**  
**Contents**

Machine Identification ..... B-3  
    Machine Identification Information ..... B-3  
Serial Number Definition ..... B-5  
Intended Use ..... B-6  
Proper Disposal of Waste ..... B-6  
Emissions Warranty ..... B-7  
EC Declaration of Conformity ..... B-10

**GENERAL INFORMATION**

---

**MACHINE IDENTIFICATION**

**Machine Identification Information**

**Plate Locations**

The product identification number (PIN) will be used to identify a powered tractor designed for an operator to ride.

Components such as engines, transmissions and major attachments that are not designed for an operator to ride are identified by serial numbers.

For quick reference, record the identification numbers in the spaces that are provided below Illustration.

**FIG. 1:** Machine pin. The plate is located on right side of frame rail

Machine PIN: \_\_\_\_\_



**FIG. 1**

**FIG. 2:** Engine Serial Number. The plate is located on left side of engine.

Engine Serial Number: \_\_\_\_\_



**FIG. 2**

**FIG. 3:** Transmission Serial Number. The plate is located on left front side of transmission above hardbar.

Transmission Serial Number: \_\_\_\_\_



**FIG. 3**

## GENERAL INFORMATION

**FIG. 4:** Cab Serial Number. The plate (1) is located outside cab on left front corner of cab.

Cab Serial Number: \_\_\_\_\_



**FIG. 4**

**FIG. 5:** Operators Seat Serial Number. The tag (1) is located on rear of operators seat.

Seat Serial Number: \_\_\_\_\_

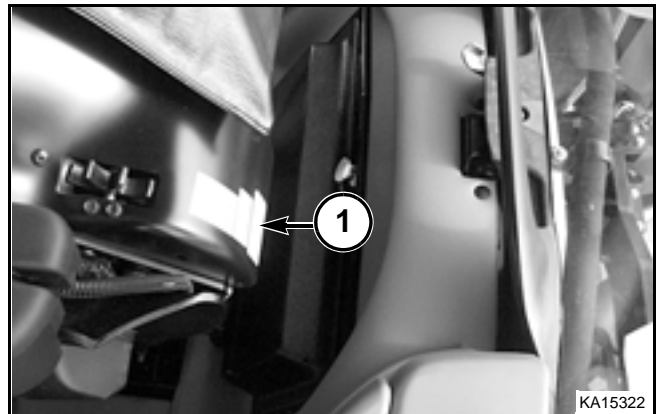

**FIG. 5**

**FIG. 6:** Track Belt Serial Number. Serial number is located on edge of each belt.

Left Belt Serial Number: \_\_\_\_\_

Right Belt Serial Number: \_\_\_\_\_



**FIG. 6**

**FIG. 7:** Serial Number for Differential and for Axles. The plate is located beneath rockshaft for three-point hitch.

Differential and Axles Serial Number: \_\_\_\_\_



**FIG. 7**

This as a preview PDF file from [best-manuals.com](http://best-manuals.com)



Download full PDF manual at [best-manuals.com](http://best-manuals.com)