

CX36B
Tier 4B (final)
Compact Hydraulic Excavator
PIN NETN36001(PX17-40001) and above

SERVICE MANUAL

Part number 47797999

1st edition English

October 2014





INTRODUCTION

Contents

INTRODUCTION

Foreword - Important notice regarding equipment servicing	3
Safety rules	4
Safety rules - Ecology and the environment (*)	5
Safety rules Personal Safety (*)	6
Basic instructions - Shop and assembly (*)	7
Torque - Minimum tightening torques for normal assembly (*)	9
Torque - Standard torque data for hydraulics (*)	12
Capacities	14
Hydraulic contamination (*)	17
General specification	18
Product identification (*)	19

(*) See content for specific models

Foreword - Important notice regarding equipment servicing

All repair and maintenance work listed in this manual must be carried out only by qualified dealership personnel, strictly complying with the instructions given, and using, whenever possible, the special tools.

Anyone who performs repair and maintenance operations without complying with the procedures provided herein shall be responsible for any subsequent damages.

The manufacturer and all the organizations of its distribution chain, including - without limitation - national, regional, or local dealers, reject any responsibility for damages caused by parts and/or components not approved by the manufacturer, including those used for the servicing or repair of the product manufactured or marketed by the manufacturer. In any case, no warranty is given or attributed on the product manufactured or marketed by the manufacturer in case of damages caused by parts and/or components not approved by the manufacturer.

The manufacturer reserves the right to make improvements in design and changes in specifications at any time without notice and without incurring any obligation to install them on units previously sold. Specifications, descriptions, and illustrative material herein are as accurate as known at time of publication but are subject to change without notice.

In case of questions, refer to your CASE CONSTRUCTION Sales and Service Networks.

Safety rules

Personal safety





This is the safety alert symbol. It is used to alert you to potential personal injury hazards. Obey all safety messages that follow this symbol to avoid possible death or injury.

Throughout this manual you will find the signal words DANGER, WARNING, and CAUTION followed by special instructions. These precautions are intended for the personal safety of you and those working with you.

Read and understand all the safety messages in this manual before you operate or service the machine.

 DANGER indicates a hazardous situation that, if not avoided, will result in death or serious injury.

 WARNING indicates a hazardous situation that, if not avoided, could result in death or serious injury.

 CAUTION indicates a hazardous situation that, if not avoided, could result in minor or moderate injury.

FAILURE TO FOLLOW DANGER, WARNING, AND CAUTION MESSAGES COULD RESULT IN DEATH OR SERIOUS INJURY.

Machine safety

NOTICE: Notice indicates a situation that, if not avoided, could result in machine or property damage.

Throughout this manual you will find the signal word Notice followed by special instructions to prevent machine or property damage. The word Notice is used to address practices not related to personal safety.

Information

NOTE: Note indicates additional information that clarifies steps, procedures, or other information in this manual.

Throughout this manual you will find the word Note followed by additional information about a step, procedure, or other information in the manual. The word Note is not intended to address personal safety or property damage.

Safety rules - Ecology and the environment

CX36B

Soil, air, and water quality is important for all industries and life in general. When legislation does not yet rule the treatment of some of the substances that advanced technology requires, sound judgment should govern the use and disposal of products of a chemical and petrochemical nature.

NOTE: *The following are recommendations that may be of assistance:*

- Familiarize yourself with the relative legislation applicable to your country, and make sure that you understand this legislation.
- Where no legislation exists, obtain information from suppliers of oils, filters, batteries, fuels, anti-freeze, cleaning agents, etc., with regard to the effect of these substances on man and nature and how to safely store, use, and dispose of these substances.

Helpful hints

- Avoid the use of cans or other inappropriate pressurized fuel delivery systems to fill tanks. Such delivery systems may cause considerable spillage.
- In general, avoid skin contact with all fuels, oils, acids, solvents, etc. Most of these products contain substances that may be harmful to your health.
- Modern oils contain additives. Do not burn contaminated fuels and or waste oils in ordinary heating systems.
- Avoid spillage when you drain fluids such as used engine coolant mixtures, engine oil, hydraulic fluid, brake fluid, etc. Do not mix drained brake fluids or fuels with lubricants. Store all drained fluids safely until you can dispose of the fluids in a proper way that complies with all local legislation and available resources.
- Do not allow coolant mixtures to get into the soil. Collect and dispose of coolant mixtures properly.
- The air-conditioning system contains gases that should not be released into the atmosphere. Consult an air-conditioning specialist or use a special extractor to recharge the system properly.
- Repair any leaks or defects in the engine cooling system or hydraulic system immediately.
- Do not increase the pressure in a pressurized circuit as this may lead to a component failure.
- Protect hoses during welding. Penetrating weld splatter may burn a hole or weaken hoses, allowing the loss of oils, coolant, etc.

Battery recycling

Batteries and electric accumulators contain several substances that can have a harmful effect on the environment if the batteries are not properly recycled after use. CASE CONSTRUCTION strongly recommends that equipment owners return all used batteries to a [Brand] dealer, who will dispose of the used batteries or recycle the used batteries properly. In some countries, this is a legal requirement.

Safety rules Personal Safety

CX36B	
-------	--

Most accidents involving machine operation and maintenance can be avoided by following basic safety rules and precautions. Read and understand all the safety messages in this manual and the safety signs on the machine before you operate or service the machine. See your dealer if you have any questions.

READ THIS MANUAL COMPLETELY and make sure you understand the controls. All equipment has a limit. Make sure you understand the speed, brakes, steering, stability, and load characteristics of the machine before you start to operate this machine.

DO NOT remove this manual from the machine.

The safety information given in this manual does not replace safety codes, insurance needs, federal, state, or local laws. Make sure that your machine has the correct equipment according to these rules or laws.

Additional safety messages are used in the text of the manual to show specific safety hazards.

NOTICE: *The safety messages in this chapter point out conditions which can happen during the normal operation and maintenance of your machine. These safety messages also give possible ways of dealing with these conditions.*

Basic instructions - Shop and assembly

CX36B	
-------	--

Shimming

For each adjustment operation, select adjusting shims and measure the adjusting shims individually using a micrometer, then add up the recorded values. Do not rely on measuring the entire shimming set, which may be incorrect, or the rated value shown on each shim.

Rotating shaft seals

For correct rotating shaft seal installation, proceed as follows:

1. Before assembly, allow the seal to soak in the oil it will be sealing for at least thirty minutes.
2. Thoroughly clean the shaft and check that the working surface on the shaft is not damaged.
3. Position the sealing lip facing the fluid.

NOTE: *With hydrodynamic lips, take into consideration the shaft rotation direction and position the grooves so that they will move the fluid towards the inner side of the seal.*

4. Coat the sealing lip with a thin layer of lubricant (use oil rather than grease). Fill the gap between the sealing lip and the dust lip on double lip seals with grease.
5. Insert the seal in its seat and press down using a flat punch or seal installation tool. Do not tap the seal with a hammer or mallet.
6. While you insert the seal, check that the seal is perpendicular to the seat. When the seal settles, make sure that the seal makes contact with the thrust element, if required.
7. To prevent damage to the seal lip on the shaft, position a protective guard during installation operations.

O-ring seals

Lubricate the O-ring seals before you insert them in the seats. This will prevent the O-ring seals from overturning and twisting, which would jeopardize sealing efficiency.

Sealing compounds

Apply a sealing compound on the mating surfaces when specified by the procedure. Before you apply the sealing compound, prepare the surfaces as directed by the product container.

Spare parts

Only use CNH Original Parts or CASE CONSTRUCTION Original Parts.

Only genuine spare parts guarantee the same quality, duration, and safety as original parts, as they are the same parts that are assembled during standard production. Only CNH Original Parts or CASE CONSTRUCTION Original Parts can offer this guarantee.

When ordering spare parts, always provide the following information:

- Machine model (commercial name) and Product Identification Number (PIN)
- Part number of the ordered part, which can be found in the parts catalog

Protecting the electronic and/or electrical systems during charging and welding

To avoid damage to the electronic and/or electrical systems, always observe the following practices:

1. Never make or break any of the charging circuit connections when the engine is running, including the battery connections.
2. Never short any of the charging components to ground.
3. Always disconnect the ground cable from the battery before arc welding on the machine or on any machine attachment.
 - Position the welder ground clamp as close to the welding area as possible.
 - If you weld in close proximity to a computer module, then you should remove the module from the machine.
 - Never allow welding cables to lie on, near, or across any electrical wiring or electronic component while you weld.
4. Always disconnect the negative cable from the battery when charging the battery in the machine with a battery charger.

NOTICE: *If you must weld on the unit, you must disconnect the battery ground cable from the machine battery. The electronic monitoring system and charging system will be damaged if this is not done.*

5. Remove the battery ground cable. Reconnect the cable when you complete welding.

⚠ WARNING

Battery acid causes burns. Batteries contain sulfuric acid.

Avoid contact with skin, eyes or clothing. Antidote (external): Flush with water. Antidote (eyes): flush with water for 15 minutes and seek medical attention immediately. Antidote (internal): Drink large quantities of water or milk. Do not induce vomiting. Seek medical attention immediately.

Failure to comply could result in death or serious injury.

W0111A

Special tools

The special tools that CASE CONSTRUCTION suggests and illustrate in this manual have been specifically researched and designed for use with CASE CONSTRUCTION machines. The special tools are essential for reliable repair operations. The special tools are accurately built and rigorously tested to offer efficient and long-lasting operation.

By using these tools, repair personnel will benefit from:

- Operating in optimal technical conditions
- Obtaining the best results
- Saving time and effort
- Working in safe conditions

Torque - Minimum tightening torques for normal assembly

CX36B

Decimal hardware

Grade 5 bolts, nuts and studs

Size	Nm	lb in/lb ft
1/4 in	12 - 15 Nm	108 - 132 lb in
5/16 in	23 - 28 Nm	204 - 252 lb in
3/8 in	48 - 57 Nm	420 - 504 lb in
7/16 in	73 - 87 Nm	54 - 64 lb ft
1/2 in	109 - 130 Nm	80 - 96 lb ft
9/16 in	149 - 179 Nm	110 - 132 lb ft
5/8 in	203 - 244 Nm	150 - 180 lb ft
3/4 in	366 - 439 Nm	270 - 324 lb ft
7/8 in	542 - 651 Nm	400 - 480 lb ft
1 in	787 - 944 Nm	580 - 696 lb ft
1-1/8 in	1085 - 1193 Nm	800 - 880 lb ft
1-1/4 in	1519 - 1681 Nm	1120 - 1240 lb ft
1-3/8 in	1980 - 2278 Nm	1460 - 1680 lb ft
1-1/2 in	2631 - 2983 Nm	1940 - 2200 lb ft

Grade 8 bolts, nuts and studs

Size	Nm	lb in/lb ft
1/4 in	16 - 20 Nm	144 - 180 lb in
5/16 in	33 - 39 Nm	288 - 348 lb in
3/8 in	61 - 73 Nm	540 - 648 lb in
7/16 in	95 - 114 Nm	70 - 84 lb ft
1/2 in	149 - 179 Nm	110 - 132 lb ft
9/16 in	217 - 260 Nm	160 - 192 lb ft
5/8 in	298 - 358 Nm	220 - 264 lb ft
3/4 in	515 - 618 Nm	380 - 456 lb ft
7/8 in	814 - 976 Nm	600 - 720 lb ft
1 in	1220 - 1465 Nm	900 - 1080 lb ft
1-1/8 in	1736 - 1953 Nm	1280 - 1440 lb ft
1-1/4 in	2468 - 2712 Nm	1820 - 2000 lb ft
1-3/8 in	3227 - 3688 Nm	2380 - 2720 lb ft
1-1/2 in	4285 - 4827 Nm	3160 - 3560 lb ft

NOTE: Use thick nuts with Grade 8 bolts.

Metric hardware

Grade 8.8 bolts, nuts and studs

Size	Nm	lb in/lb ft
4 mm	3 - 4 Nm	24 - 36 lb in
5 mm	7 - 8 Nm	60 - 72 lb in
6 mm	11 - 12 Nm	96 - 108 lb in
8 mm	26 - 31 Nm	228 - 276 lb in
10 mm	52 - 61 Nm	456 - 540 lb in
12 mm	90 - 107 Nm	66 - 79 lb ft
14 mm	144 - 172 Nm	106 - 127 lb ft
16 mm	217 - 271 Nm	160 - 200 lb ft
20 mm	434 - 515 Nm	320 - 380 lb ft
24 mm	675 - 815 Nm	500 - 600 lb ft
30 mm	1250 - 1500 Nm	920 - 1100 lb ft
36 mm	2175 - 2600 Nm	1600 - 1950 lb ft

INTRODUCTION

Grade 10.9 bolts, nuts and studs

Size	Nm	lb in/lb ft
4 mm	4 - 5 Nm	36 - 48 lb in
5 mm	9 - 11 Nm	84 - 96 lb in
6 mm	15 - 18 Nm	132 - 156 lb in
8 mm	37 - 43 Nm	324 - 384 lb in
10 mm	73 - 87 Nm	54 - 64 lb ft
12 mm	125 - 150 Nm	93 - 112 lb ft
14 mm	200 - 245 Nm	149 - 179 lb ft
16 mm	310 - 380 Nm	230 - 280 lb ft
20 mm	610 - 730 Nm	450 - 540 lb ft
24 mm	1050 - 1275 Nm	780 - 940 lb ft
30 mm	2000 - 2400 Nm	1470 - 1770 lb ft
36 mm	3500 - 4200 Nm	2580 - 3090 lb ft

Grade 12.9 bolts, nuts and studs

Size	Nm	lb in/lb ft
Typically the torque values specified for grade 10.9 hardware can be used satisfactorily on grade 12.9 hardware.		

Steel hydraulic fittings

37° flare fitting

Tube outside diameter/Hose inside diameter		Thread size	Nm	lb in/lb ft
mm	inch			
6.4 mm	1/4 in	7/16-20 in	8 - 16 Nm	72 - 144 lb in
7.9 mm	5/16 in	1/2-20 in	11 - 22 Nm	96 - 192 lb in
9.5 mm	3/8 in	9/16-18 in	14 - 34 Nm	120 - 300 lb in
12.7 mm	1/2 in	3/4-16 in	20 - 57 Nm	180 - 504 lb in
15.9 mm	5/8 in	7/8-14 in	34 - 79 Nm	300 - 696 lb in
19.0 mm	3/4 in	1-1/16-12 in	54 - 108 Nm	40 - 80 lb ft
22.2 mm	7/8 in	1-3/16-12 in	81 - 135 Nm	60 - 100 lb ft
25.4 mm	1 in	1-5/16-12 in	102 - 158 Nm	75 - 117 lb ft
31.8 mm	1-1/4 in	1-5/8-12 in	169 - 223 Nm	125 - 165 lb ft
38.1 mm	1-1/2 in	1-7/8-12 in	285 - 338 Nm	210 - 250 lb ft

Straight threads with O-ring

Tube outside diameter/Hose inside diameter		Thread size	Nm	lb in/lb ft
mm	inch			
6.4 mm	1/4 in	7/16-20 in	16 - 26 Nm	144 - 228 lb in
7.9 mm	5/16 in	1/2-20 in	22 - 34 Nm	192 - 300 lb in
9.5 mm	3/8 in	9/16-18 in	34 - 54 Nm	300 - 480 lb in
12.7 mm	1/2 in	3/4-16 in	57 - 91 Nm	540 - 804 lb in
15.9 mm	5/8 in	7/8-14 in	79 - 124 Nm	58 - 92 lb ft
19.0 mm	3/4 in	1-1/16-12 in	108 - 174 Nm	80 - 128 lb ft
22.2 mm	7/8 in	1-3/16-12 in	136 - 216 Nm	100 - 160 lb ft
25.4 mm	1 in	1-5/16-12 in	159 - 253 Nm	117 - 187 lb ft
31.8 mm	1-1/4 in	1-5/8-12 in	224 - 357 Nm	165 - 264 lb ft
38.1 mm	1-1/2 in	1-7/8-12 in	339 - 542 Nm	250 - 400 lb ft

Split flange mounting bolts

Size	Nm	lb in/lb ft
5/16-18 in	20 - 27 Nm	180 - 240 lb in
3/8-16 in	27 - 34 Nm	240 - 300 lb in
7/16-14 in	47 - 61 Nm	420 - 540 lb in
1/2-13 in	74 - 88 Nm	55 - 65 lb ft

INTRODUCTION

Size	Nm	lb in/lb ft
5/8-11 in	190 - 203 Nm	140 - 150 lb ft

Nominal SAE dash size	O-ring face seal end		Thread size	Nm	lb in/lb ft	O-ring boss end fitting or lock nut		
	Tube outside diameter mm	in				Thread size	Nm	lb in/lb ft
-4	6.4 mm	1/4 in	9/16-18 in	14 - 16 Nm	120 - 144 lb in	7/16-20 in	23 - 27 Nm	204 - 240 lb in
-6	9.5 mm	3/8 in	11/16-16 in	24 - 27 Nm	216 - 240 lb in	9/16-18 in	34 - 41 Nm	300 - 360 lb in
-8	12.7 mm	1/2 in	13/16-16 in	43 - 54 Nm	384 - 480 lb in	3/4-16 in	61 - 68 Nm	540 - 600 lb in
-10	15.9 mm	5/8 in	1-14 in	62 - 76 Nm	552 - 672 lb in	7/8-14 in	81 - 88 Nm	60 - 65 lb ft
-12	19.0 mm	3/4 in	1-3/16-12 in	90 - 110 Nm	65 - 80 lb ft	1-1/16-12 in	115 - 122 Nm	85 - 90 lb ft
-14	22.2 mm	7/8 in	1-3/16-12 in	90 - 110 Nm	65 - 80 lb ft	1-13/16-12 in	129 - 136 Nm	95 - 100 lb ft
-16	25.41 mm	1.0 in	1-7/16-12 in	125 - 140 Nm	92 - 105 lb ft	1-5/16-12 in	156 - 169 Nm	115 - 125 lb ft
-20	31.8 mm	1-1/4 in	1-11/16-12 in	170 - 190 Nm	125 - 140 lb ft	1-5/8-12 in	201 - 217 Nm	150 - 160 lb ft
-24	38.1 mm	1-1/2 in	2-12 in	200 - 254 Nm	150 - 180 lb ft	1-7/8-12 in	258 - 271 Nm	190 - 200 lb ft

Torque - Standard torque data for hydraulics

CX36B

Installation of adjustable fittings in straight thread O-ring bosses

1. Lubricate the O-ring by coating it with a light oil or petroleum. Install the O-ring in the groove adjacent to the metal backup washer which is assembled at the extreme end of the groove (4).
2. Install the fitting into the SAE straight thread boss until the metal backup washer contacts the face of the boss (5).

NOTE: Do not over tighten and distort the metal backup washer.

3. Position the fitting by turning out (counterclockwise) up to a maximum of one turn. Holding the pad of the fitting with a wrench, tighten the locknut and washer against the face of the boss (6).

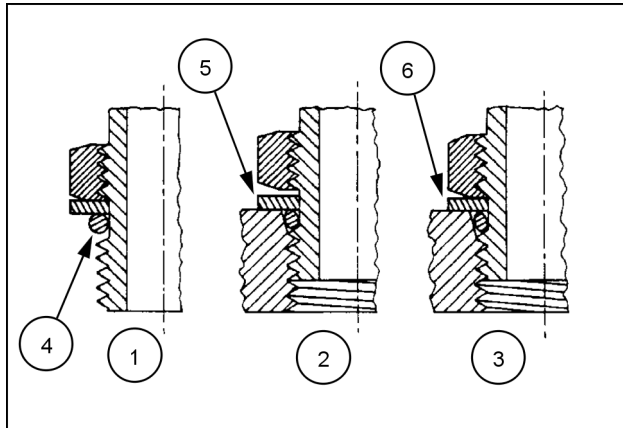

23085659 1

Standard torque data for hydraulic tubes and fittings

Tube nuts for 37° flared fittings				O-ring boss plugs adjustable fitting locknuts, swivel JIC-37° seats
Size	Tubing OD	Thread size	Torque	Torque
4	6.4 mm (1/4 in)	7/16-20	12 - 16 N·m (9 - 12 lb ft)	8 - 14 N·m (6 - 10 lb ft)
5	7.9 mm (5/16 in)	1/2-20	16 - 20 N·m (12 - 15 lb ft)	14 - 20 N·m (10 - 15 lb ft)
6	9.5 mm (3/8 in)	9/16-18	29 - 33 N·m (21 - 24 lb ft)	20 - 27 N·m (15 - 20 lb ft)
8	12.7 mm (1/2 in)	3/4-16	47 - 54 N·m (35 - 40 lb ft)	34 - 41 N·m (25 - 30 lb ft)
10	15.9 mm (5/8 in)	7/8-14	72 - 79 N·m (53 - 58 lb ft)	47 - 54 N·m (35 - 40 lb ft)
12	19.1 mm (3/4 in)	1-1/16-12	104 - 111 N·m (77 - 82 lb ft)	81 - 95 N·m (60 - 70 lb ft)
14	22.2 mm (7/8 in)	1-3/16-12	122 - 136 N·m (90 - 100 lb ft)	95 - 109 N·m (70 - 80 lb ft)
16	25.4 mm (1 in)	1-5/16-12	149 - 163 N·m (110 - 120 lb ft)	108 - 122 N·m (80 - 90 lb ft)
20	31.8 mm (1-1/4 in)	1-5/8-12	190 - 204 N·m (140 - 150 lb ft)	129 - 158 N·m (95 - 115 lb ft)
24	38.1 mm (1-1/2 in)	1-7/8-12	217 - 237 N·m (160 - 175 lb ft)	163 - 190 N·m (120 - 140 lb ft)
32	50.8 mm (2 in)	2-1/2-12	305 - 325 N·m (225 - 240 lb ft)	339 - 407 N·m (250 - 300 lb ft)

These torques are not recommended for tubes of 12.7 mm (1/2 in) OD and larger with wall thickness of 0.889 mm (0.035 in) or less. The torque is specified for 0.889 mm (0.035 in) wall tubes on each application individually.

Before installing and torquing 37° flared fittings, clean the face of the flare and threads with a clean solvent or Loctite cleaner and apply hydraulic sealant **LOCTITE® 569™** to the 37° flare and the threads.

Install fitting and torque to specified torque, loosen fitting and retorque to specifications.

Pipe thread fitting torque

Before installing and tightening pipe fittings, clean the threads with a clean solvent or Loctite cleaner and apply sealant **LOCTITE® 567™ PST PIPE SEALANT** for all fittings including stainless steel or **LOCTITE® 565™ PST** for most metal fittings. For high filtration/zero contamination systems use **LOCTITE® 545™**.

Thread size	Torque (maximum)
1/8-27	13 N·m (10 lb ft)
1/4-18	16 N·m (12 lb ft)
3/8-18	22 N·m (16 lb ft)
1/2-14	41 N·m (30 lb ft)
3/4-14	54 N·m (40 lb ft)

Installation of ORFS (O-Ring Flat Seal fittings)

When installing ORFS fittings thoroughly clean both flat surfaces of the fittings **(1)** and lubricate the O-ring **(2)** with light oil. Make sure both surfaces are aligned properly. Torque the fitting to specified torque listed throughout the repair manual.

NOTICE: *If the fitting surfaces are not properly cleaned, the O-ring will not seal properly. If the fitting surfaces are not properly aligned, the fittings may be damaged and will not seal properly.*

NOTICE: *Always use genuine factory replacement oils and filters to ensure proper lubrication and filtration of engine and hydraulic system oils.*

The use of proper oils, grease, and keeping the hydraulic system clean will extend machine and component life.

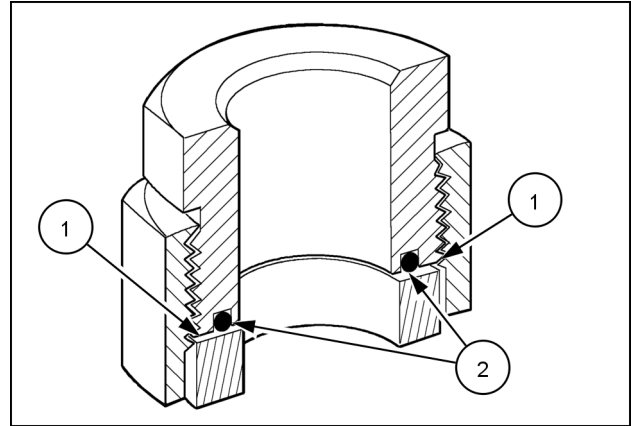

50011183 2

Capacities

Component to be filled	Quantity	Consumable	Manufacturer specifications	International specifications
Engine oil pan	3.9 - 6.7 L (1.0 - 1.8 US gal)	CASE AKCELA NO. 1™ ENGINE OIL SAE 10W-30	MAT3507	API CI 4/CH-4 ACEA E7/E5
		CASE AKCELA NO. 1™ ENGINE OIL SAE 15W-40	MAT3507	
Travel motor	0.6 L (0.2 US gal) x 2	CASE AKCELA GEAR 135 H EP 80W-90	MAT3511	API GL 5
Upper rollers	55.0 cm ³ (3.4 in ³) x 2			
Idler wheels	80.0 cm ³ (4.9 in ³) x 2			
Lower rollers	65.0 cm ³ (4.0 in ³) x 10	CASE AKCELA ENGINE OIL 10W-30	MAT3521	API CI 4/CH-4 ACEA E7/E5
Radiator (1)	1.8 L (0.5 US gal) 3.8 L (1.0 US gal) (total system)	CASE AKCELA PREMIUM ORGANIC ANTI-FREEZE	—	ASTM D 3306
Fuel tank	42.0 L (11.1 US gal)	—	—	EN 590
Hydraulic oil tank (2)	20.4 L (5.4 US gal) 44.8 L (11.8 US gal) (hydraulic system)	CASE AKCELA HYDRAULIC EXCAVATOR FLUID	MAT3509	—
Boom, arm, linkage, and attachment	15 places	CASE AKCELA MOLY GREASE	MAT3550	NLGI 2
Dozer blade cylinder	4 places			
Slewing bearing	1 place			
Boom swing cylinder pin	2 place			
Operating lever and pedal	As needed, disassembly is required			
Swing pinion	1 place	CASE AKCELA MOLY GREASE	MAT3550	NLGI 2
Air conditioning	0.60 kg (1.32 lb)	R134A	—	—
Compressor	120 cm ³ (7.32 in ³)	SANDEN SP-10 LUBRICANT	—	—

NOTE: (1) Coolant to be mixed with water at 50 %. Cooling system total volume: ~ 6 l (1.59 US gal)

NOTICE: (2) Hydraulic system total volume: ~ 44.8 L (11.8 US gal) . If the machine was filled with biodegradable hydraulic oil PANOLIN HLP SYNTH 46 (option), take note that this oil cannot be mixed with mineral hydraulic oil.

Temperature operating ranges

	Consumable	Viscosity	Temperature operating range
Engine	CASE AKCELA NO. 1™ ENGINE OIL	SAE 10W - 30	-25.0 - 25.0 °C (-13.0 - 77.0 °F)
		SAE 15W - 40	-15.0 - 40.0 °C (5.0 - 104.0 °F)
Travel motor, upper rollers and idler wheels	CASE AKCELA GEAR 135 H EP 80W-90	SAE 80W - 90	-25.0 - 45.0 °C (-13.0 - 113.0 °F)
Hydraulic system	CASE AKCELA HYDRAULIC EXCAVATOR FLUID	ISO VG-46	-20.0 - 50.0 °C (-4.0 - 122.0 °F)

Use of biodegradable oils

When you use biodegradable oil, please refer to following:

- There are two types of biodegradable oil available: vegetable-based and synthetic-based. We recommend using synthetic oils, because vegetable ones have a maximum operating temperature of **80 °C (176 °F)**. For this reason, the degradation of vegetable-based oil occurs more rapidly, and they have a reduced service life.
- Do not mix bio-oil with original factory-filled mineral oil; in case it is necessary to use bio-oil, flush the hydraulic system that was filled with bio-oil three times.
- If you use bio-oil, the performance of the rotation brake and that of the parking/travel brake will be reduced, because of the lower friction factor of bio-oil compared to that of mineral oil.
- For further information about the type of biodegradable lubricant and the relevant specifications for use and maintenance, please refer to chapter ACCESSORIES.

Use of coolant

- There are two types of coolant depending on the corrosion inhibitors base: ORGANIC-base and INORGANIC base.
- Both type can be used, BUT THEY CANNOT BE MIXED. Flush the cooling system before change coolant type.

Hydraulic contamination

CX36B	
-------	--

Contamination in the hydraulic system is a major cause of the malfunction of hydraulic components. Contamination is any foreign material in the hydraulic oil.

Contamination can enter the hydraulic system in several ways:

- When you drain the oil or disconnect any line
- When you disassemble a component
- From normal wear of the hydraulic components
- From damaged seals or worn seals
- From a damaged component in the hydraulic system

All hydraulic systems operate with some contamination. The design of the components in this hydraulic system permits efficient operation with a small amount of contamination. An increase in this amount of contamination can cause problems in the hydraulic system.

The following list includes some of these problems:

- Cylinder rod seals that leak
- Control valve spools that do not return to neutral
- Movement of control valve spools is difficult
- Hydraulic oil that becomes too hot
- Pump gears, housing, and other parts that wear rapidly
- Relief valves or check valves held open by dirt
- Quick failure of components that have been repaired
- Slow cycle times are slow. The machine does not have enough power.

If your machine has any of these problems, check the hydraulic oil for contamination.

There are two types of contamination: microscopic and visible.

Microscopic contamination occurs when very fine particles of foreign material are suspended in the hydraulic oil. These particles are too small to see or feel. Microscopic contamination can be found by identification of the following problems or by testing in a laboratory.

Examples of problems caused by microscopic contamination:

- Cylinder rod seals that leak
- Control valve spools that do not return to neutral
- The hydraulic system has a high operating temperature

Visible contamination is foreign material that can be found by sight, touch, or odor. Visible contamination can cause a sudden failure of components.

Examples of problems caused by visible contamination:

- Particles of metal or dirt in the oil
- Air in the oil
- Dark or thick oil
- Oil with an odor of burned oil
- Water in the oil

If you find contamination, use a portable filter to clean the hydraulic system.

General specification

Complete machine weight

Rubber crawler belt		Iron crawler shoe	
Canopy	Cab	Canopy	Cab
3650 kg (8047 lb)	3810 kg (8400 lb)	3740 kg (8245 lb)	3900 kg (8598 lb)

Speed and gradeability

Detail	Rubber crawler belt		Iron crawler shoe	
Rotation speed	8.4 RPM			
Travel speed	Low (1 st)	High (2 nd)	Low (1 st)	High (2 nd)
	2.5 km/h (1.6 mph)	4.4 km/h (2.7 mph)	2.5 km/h (1.3 mph)	4.2 km/h (2.6 mph)
Gradient	58 % (30 °)			

Engine

Model	YANMAR 3TNV88F-E
Total displacement	1.642 L (81.16 in³)
Power	Maximum power 17.2 kW (23.4 Hp) at 2400 RPM

Swing and dozer

Type	Boom swing by hydraulic cylinder	
Boom swing angle	Right	60 °
	Left	70 °
Stroke of dozer (up/down)	395.0 mm (15.6 in)/ 320.0 mm (12.6 in)	

Product identification

CX36B	
-------	--

The terms right-hand, left-hand, front, and rear are used in this manual to indicate the sides as they are seen from the operator's seat.

1. Front
2. Right
3. Rear
4. Left

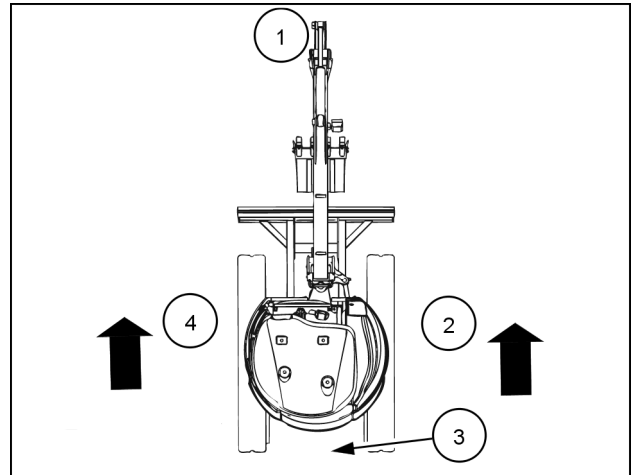

RAIL14CEX0007AA 1



SERVICE MANUAL

Machine completion and equipment

**CX36B Cab TIER 4B (FINAL)
CX36B Canopy TIER 4B (FINAL)**

Contents

Machine completion and equipment - 05

[05.102] Machine completion	05.1
-----------------------------------	------



Machine completion and equipment - 05

Machine completion - 102

CX36B Cab TIER 4B (FINAL)
CX36B Canopy TIER 4B (FINAL)

Contents

Machine completion and equipment - 05

Machine completion - 102

TECHNICAL DATA

Machine completion	
General specification	3
General specification Machine dimensions	5
General specification Specifications and performance	6
Weight Machine and components mass (Dry weight)	7
General specification Transportation	8
General specification Crawler shoes	11
General specification Bucket	11
General specification Machine dimensions (*)	11
General specification Specifications and performance (*)	13
Weight Machine and components mass (Dry weight) (*)	14

(*) See content for specific models

Machine completion - General specification

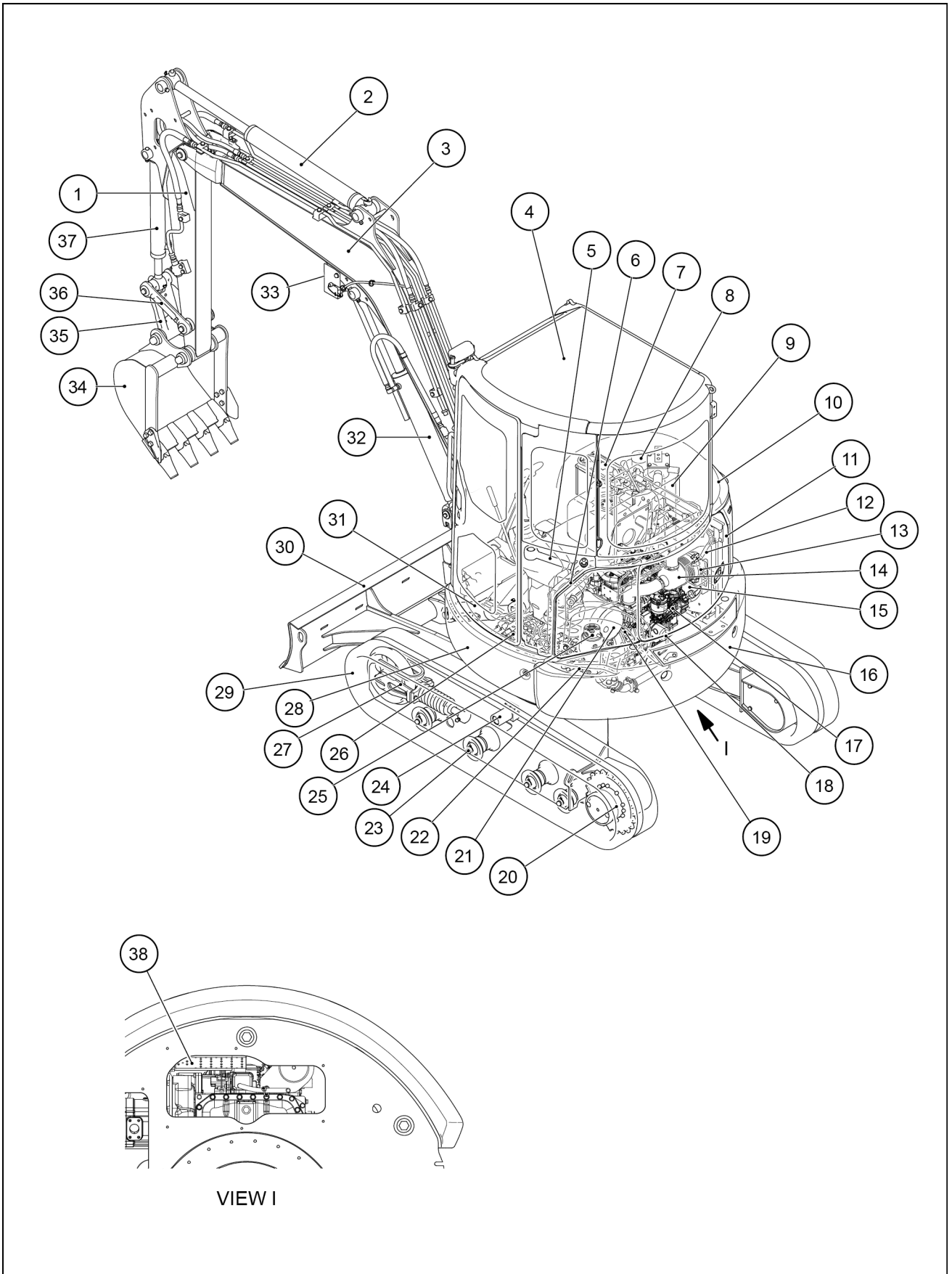

RAIL14CEX1325HA 1

Machine completion and equipment - Machine completion

1	Arm	20	Travel motor
2	Arm cylinder	21	Muffler
3	Boom	22	Swing bearing
4	Cab	23	Lower roller
5	Boom swing cylinder	24	Upper roller
6	Swing motor	25	Swivel joint
7	Battery	26	Control valve
8	Fuel tank	27	Idler assembly
9	Hydraulic oil tank	28	Guard
10	Right side cover	29	Rubber track shoe
11	Radiator	30	Dozer
12	Engine hood	31	Dozer cylinder
13	Reserve tank	32	Boom cylinder
14	Air cleaner	33	Light
15	Fuel cooler	34	Bucket
16	Counter weight	35	Bucket link
17	Engine	36	Idler link
18	Oil filter	37	Bucket cylinder
19	Hydraulic pump	38	Tail pipe

Machine with cab

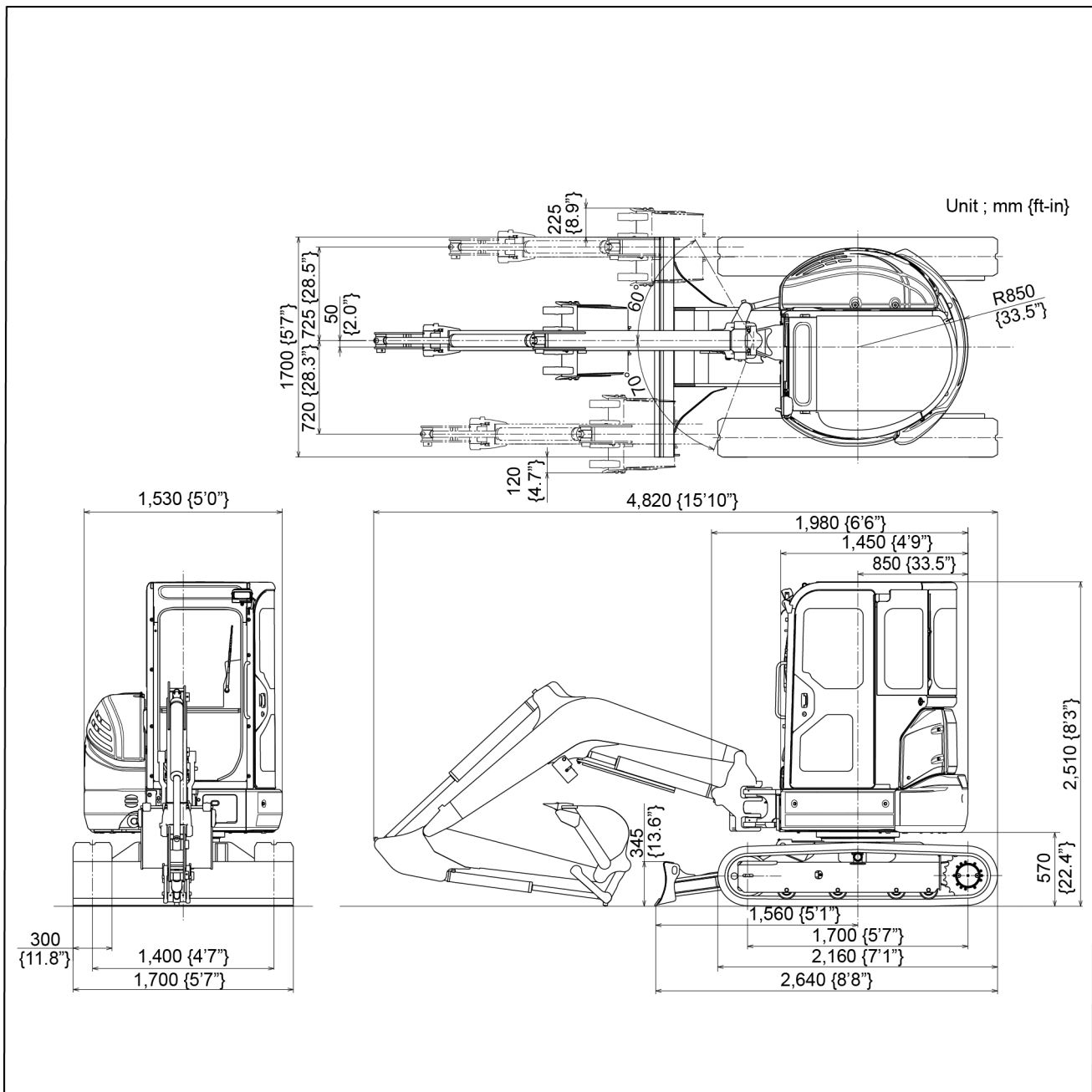

RAIL14CEX1351GA 2

Machine completion - General specification Specifications and performance

Speed and gradeability

Shoe type	Rubber shoe		Iron shoe	
Swing speed	8.4 RPM			
Travel speed	Low (1st)	High (2nd)	Low (1st)	High (2nd)
	2.5 km/h (1.6 mph)	4.4 km/h (2.7 mph)	2.5 km/h (1.6 mph)	4.2 km/h (2.6 mph)
Gradeability % (degree)	58(30)			

Engine

Type	Water cooled, 4-cycle type swirl chamber type diesel engine
Number of cylinders - Bore X Stroke	3 - 88 dia. mm X 90 mm (3.34 in. X 3.54 in.)
Total displacement	1.642 L (100.2 in³)
Output rating	18.2 kW at 2400 RPM 24.8 Hp at 2400 RPM
Maximum torque	83.4 N·m at 1440 RPM 92.2 lb ft at 1440 RPM
Starting motor	12 V X 1.7 kW
Alternator	12 V X 55 A

Hydraulic components

Hydraulic pump	Variable displacement axial piston and gear pump
Hydraulic motor	Axial piston
Hydraulic motor with reducer (Travel)	2-Axial piston, 2-Speed motor
Control valve	10-multiple control valve
Cylinder (Boom, Arm, Boom swing, Bucket, and Dozer)	Double action cylinder
Return filter	Filter type $\beta 10 \geq 8 \mu$

Side digging and dozer

Type	Boom swing by hydraulic cylinder	
Boom swing angle	Right	60 °
	Left	70 °
Stroke of the dozer — above/below		395.0 mm (15.6 in)
		320.0 mm (12.6 in)

Mass

Machine mass	Canopy		Cab	
	Rubber shoe	Iron shoe	Rubber shoe	Iron shoe
	3650 kg (8050 lb)	3740 kg (8250 lb)	3810 kg (8400 lb)	3900 kg (8600 lb)
Upper swing body	2055 kg (4530 lb)		2220 kg (4900 lb)	
Travel system	1750 kg (3858 lb)	1900 kg (4189 lb)	1750 kg (3858 lb)	1900 kg (4189 lb)
Attachment (Boom + standard arm + standard bucket)	465 kg (1030 lb)			
Oil & water	80 kg (175 lb)			

Machine completion - Weight Machine and components mass (Dry weight)

	Rubber shoe		Steel shoe	
	Canopy	Cab	Canopy	Cab
Complete machine	3650.0 kg (8046.9 lb)	3810.0 kg (8399.6 lb)	3740.0 kg (8245.3 lb)	3900.0 kg (8598.0 lb)
Upper frame assembly	2055.0 kg (4530.5 lb)	2220.0 kg (4894.3 lb)	2055.0 kg (4530.5 lb)	2220.0 kg (4894.3 lb)
Upper frame	410.0 kg (903.9 lb)			
Canopy/ Cab	73.0 kg (160.9 lb)	216.0 kg (476.2 lb)	73.0 kg (160.9 lb)	216.0 kg (476.2 lb)
Engine	150.0 kg (330.7 lb)			
Hydraulic pump	21.0 kg (46.3 lb)			
Radiator	3.0 kg (6.6 lb)			
Hydraulic tank	30.0 kg (66.1 lb)			
Fuel tank	4.0 kg (8.8 lb)			

Boom swing bracket	77.0 kg (169.8 lb)		
Boom swing cylinder	30.0 kg (66.1 lb)		
Swing motor	35.0 kg (77.2 lb)		
Control valve	25.0 kg (55.1 lb)		
Counter weight	665.0 kg (1466.1 lb)		
Guard - Bonnet	87.0 kg (191.8 lb)		
Boom cylinder	40.0 kg (88.2 lb)		
Lower frame assembly	1210.0 kg (2667.6 lb)	1300.0 kg (2866.0 lb)	
Lower frame	375.0 kg (826.7 lb)		
Swing bearing	43.0 kg (94.8 lb)		
Travel motor	36.0 kg (79.4 lb) X 2		
Lower roller	9.0 kg (19.8 lb) X 8		
Front idler	24.0 kg (52.9 lb) X 2		
Idler adjuster	14.0 kg (30.9 lb) X 2		
Sprocket	11.0 kg (24.3 lb) X 2		
300.0 mm (11.8 in) Rubber crawler shoe	146.0 kg (321.9 lb)		
Iron shoe	192.0 kg (423.3 lb)		
Swivel joint	22.0 kg (48.5 lb)		
Dozer	175.0 kg (385.8 lb)		
Dozer cylinder	23.0 kg (50.7 lb)		
Attachment assembly	465.0 kg (1025.1 lb)		
Boom assembly	248.0 kg (546.7 lb)		
Boom	141.0 kg (310.9 lb)		
Arm cylinder	39.0 kg (86.0 lb)		
Arm assembly	134.0 kg (295.4 lb)		
Arm	74.0 kg (163.1 lb)		
Bucket cylinder	23.0 kg (50.7 lb)		
Bucket link	10.0 kg (22.0 lb)		
Idler link	4.0 kg (8.8 lb) X 2		
Stand bucket assembly	83.0 kg (183.0 lb)		
	Rubber shoe		Steel shoe
	Canopy	Cab	Canopy Cab
Fluids	80.0 kg (176.4 lb)		
Hydraulic oil	40.0 kg (88.2 lb)		
Fuel	35.0 kg (77.2 lb)		
Coolant	5.0 kg (11.0 lb)		

Machine completion - General specification Transportation

Loading the machine on a trailer

1. Keep the trailer bed clean. Place chocks against the truck wheels.
2. Use a ramp or a loading deck. Ramps must be strong, have a low angle, and correct height. Load and unload the machine on a level surface.
3. Drive machine onto the ramps slowly. Center the machine over the trailer.
4. Lower all attachments.
5. Stop the engine. Remove key from the ignition switch.
6. Do not place chains against the hydraulic lines or the hydraulic hoses. Do not place chains over the hydraulic lines or the hydraulic hoses.

7. Fasten the machine to the trailer with chains or cables. During transportation, the bucket or attachments may hit the cab. Therefore, set the machine in the transporting position by observing following points:
 - a. Extend the bucket cylinder fully.
 - b. Extend the arm cylinder fully.
 - c. Lower the boom.
 - d. If the machine cannot be transported with the arm cylinder fully extended, remove the bucket or attachment then extend arm cylinder.

Transportation dimensions and mass of the attachments

Boom with arm cylinder

Dimensions L x H x W	2560.0 mm (100.8 in) X 940.0 mm (37.0 in) X 250.0 mm (9.8 in)
Mass	180.0 kg (396.8 lb)

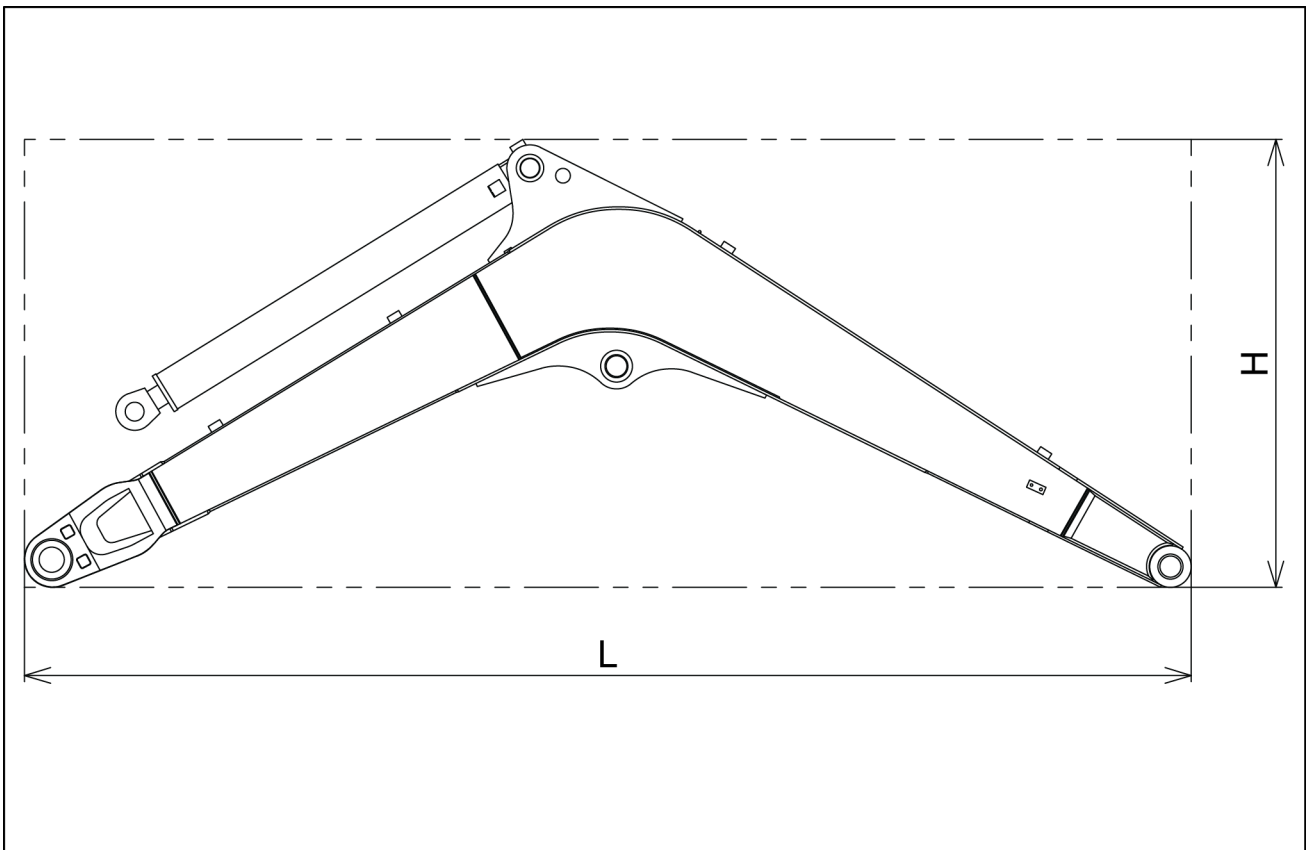

RAIL14CEX1381FA 1

Arm

Dimensions L x H x W	1800.0 mm (70.9 in) X 420.0 mm (16.5 in) X 220.0 mm (8.7 in)
Mass	130.0 kg (286.6 lb)

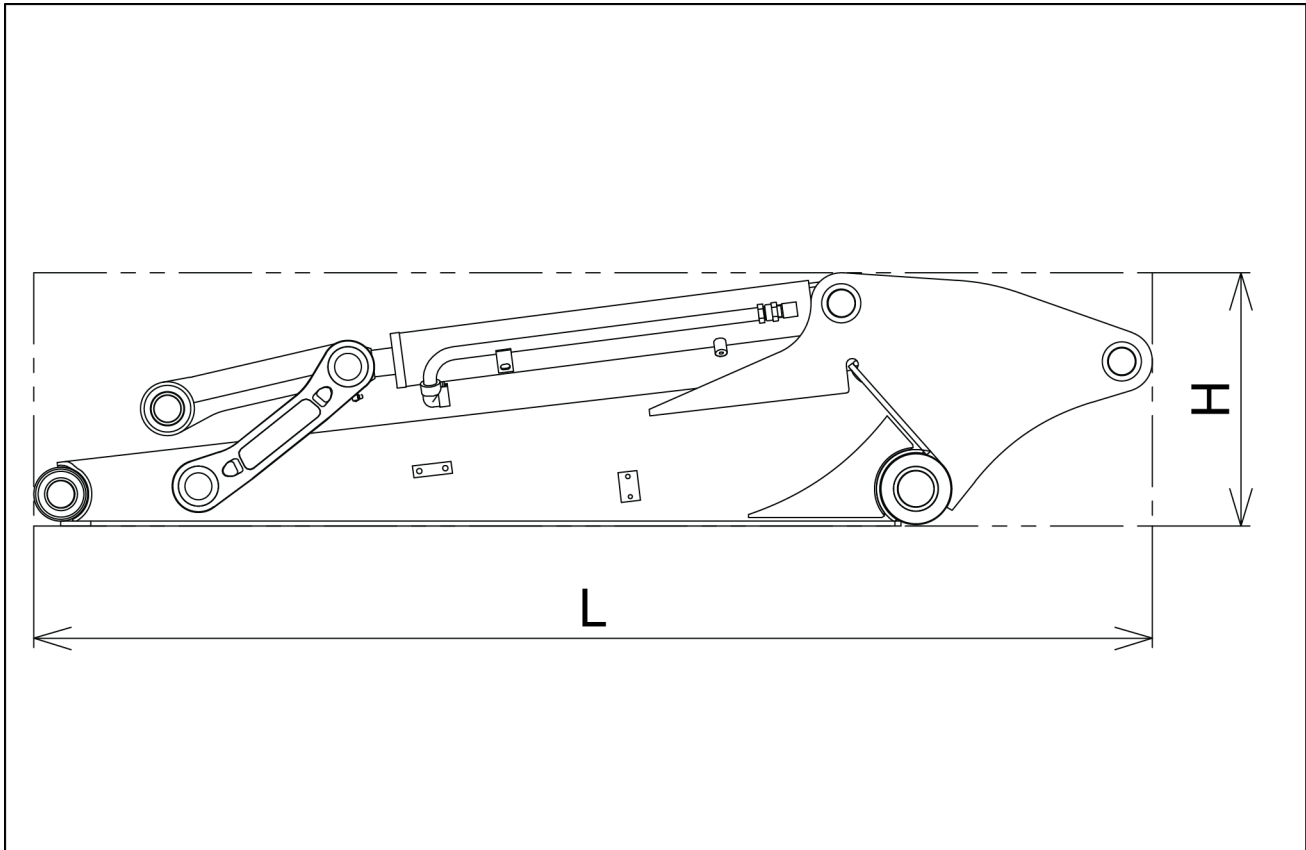

RAIL14CEX1382FA 2

Dozer (without cylinders)

Dimensions L x H x W	1240.0 mm (48.8 in) X 330.0 mm (13.0 in) X 1700.0 mm (66.9 in)
Mass	180.0 kg (396.8 lb)

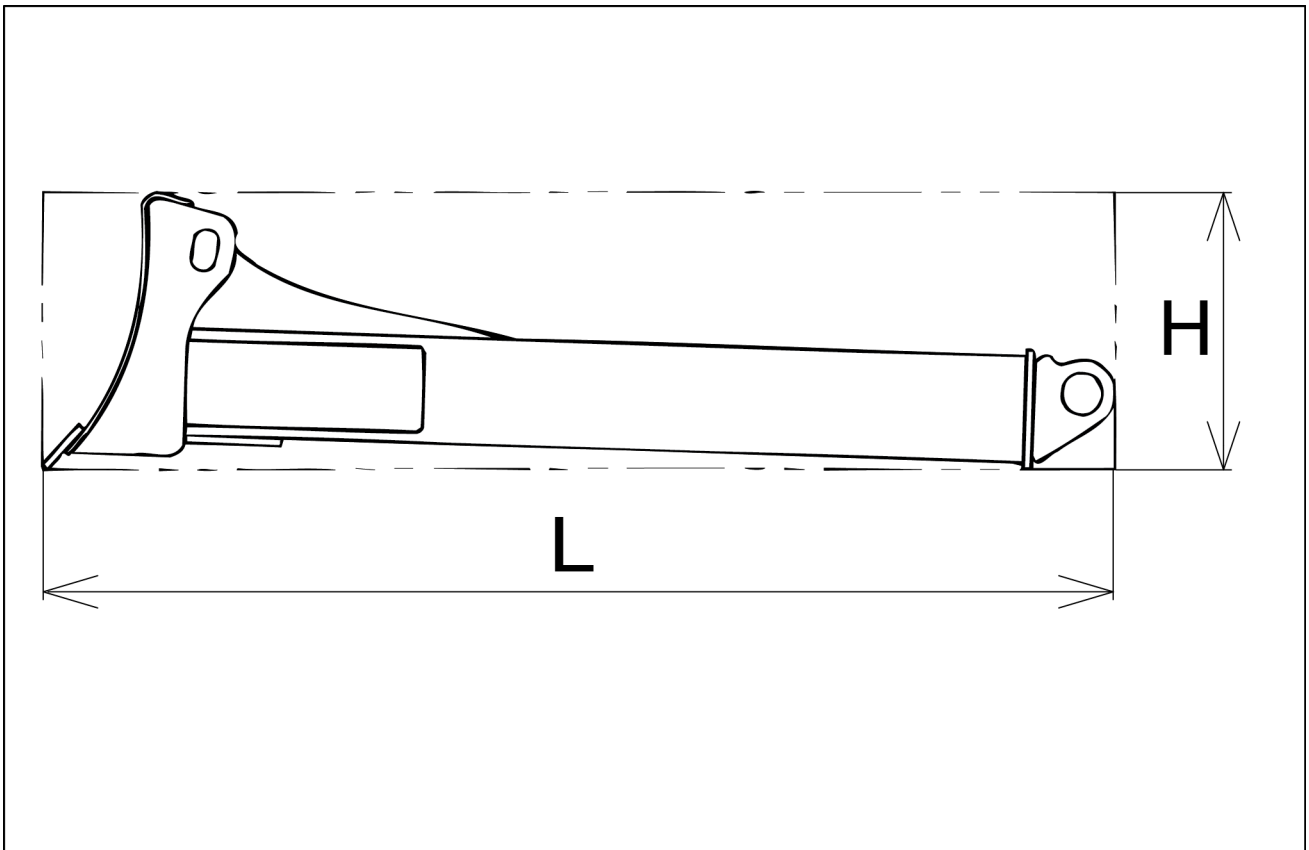

RAIL14CEX1380FA 3

Machine completion - General specification Crawler shoes

	Width	Length between the center of the idler to the center of the travel motor	Ground pressure	
			Canopy	Cab
Rubber track	300.0 mm (11.8 in)	1700.0 mm (66.9 in)	33.2 kPa (4.8 psi)	33.8 kPa (4.9 psi)
Steel tracks	300.0 mm (11.8 in)	1700.0 mm (66.9 in)	32.4 kPa (4.7 psi)	34.6 kPa (5.0 psi)

Machine completion - General specification Bucket

Heaped capacity	Outer diameter		Number of teeth	Mass	Remarks
	With side cutter	Without side cutter			
0.10 m ³ (0.13 yd ³)	600.0 mm (23.6 in)	560.0 mm (22.0 in)	4	83.0 kg (183.0 lb)	Standard bucket

Machine completion - General specification Machine dimensions

CX36B	
-------	--

Machine with canopy

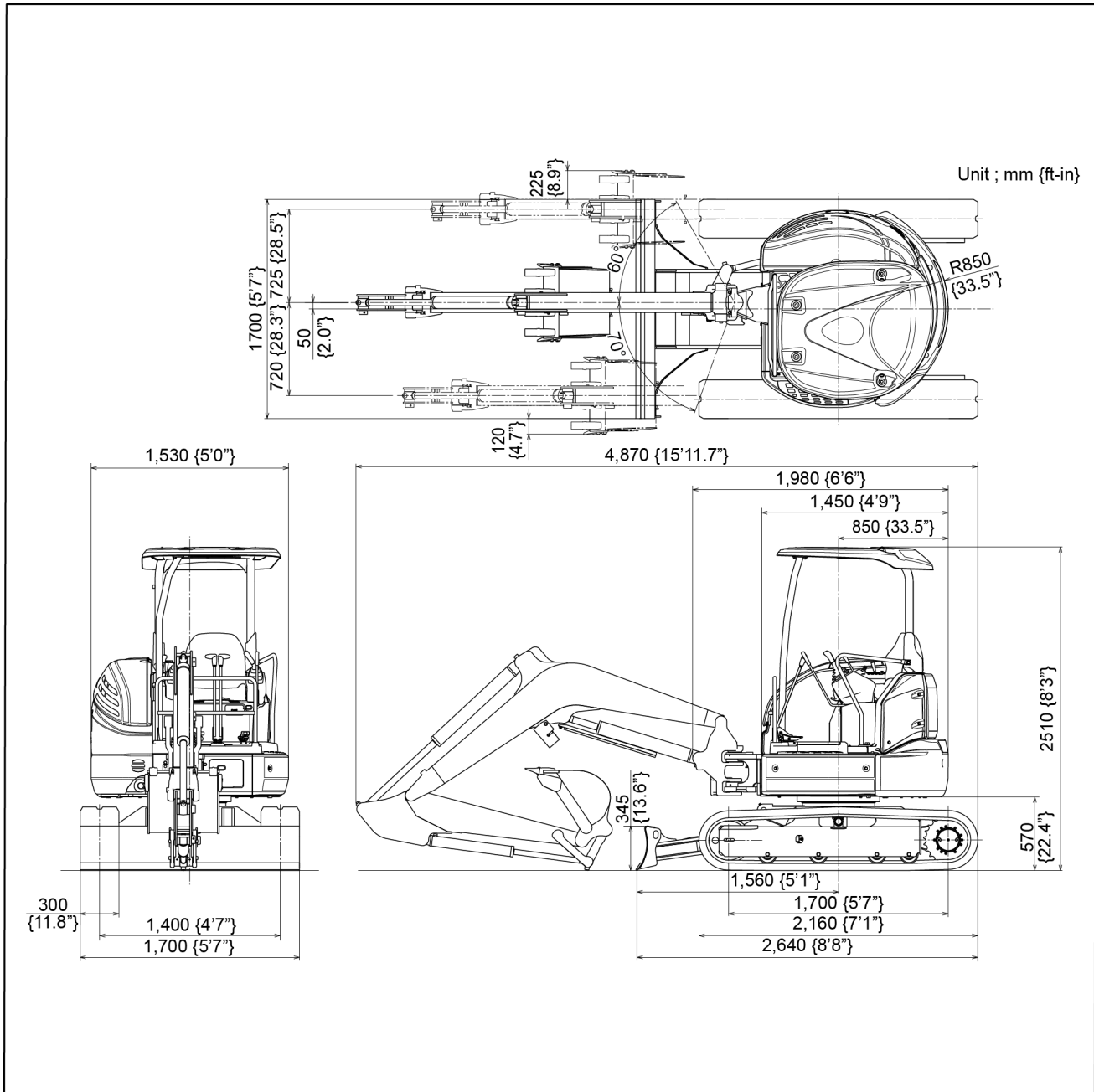

RAIL14CEX1744GA 1

Machine with cab

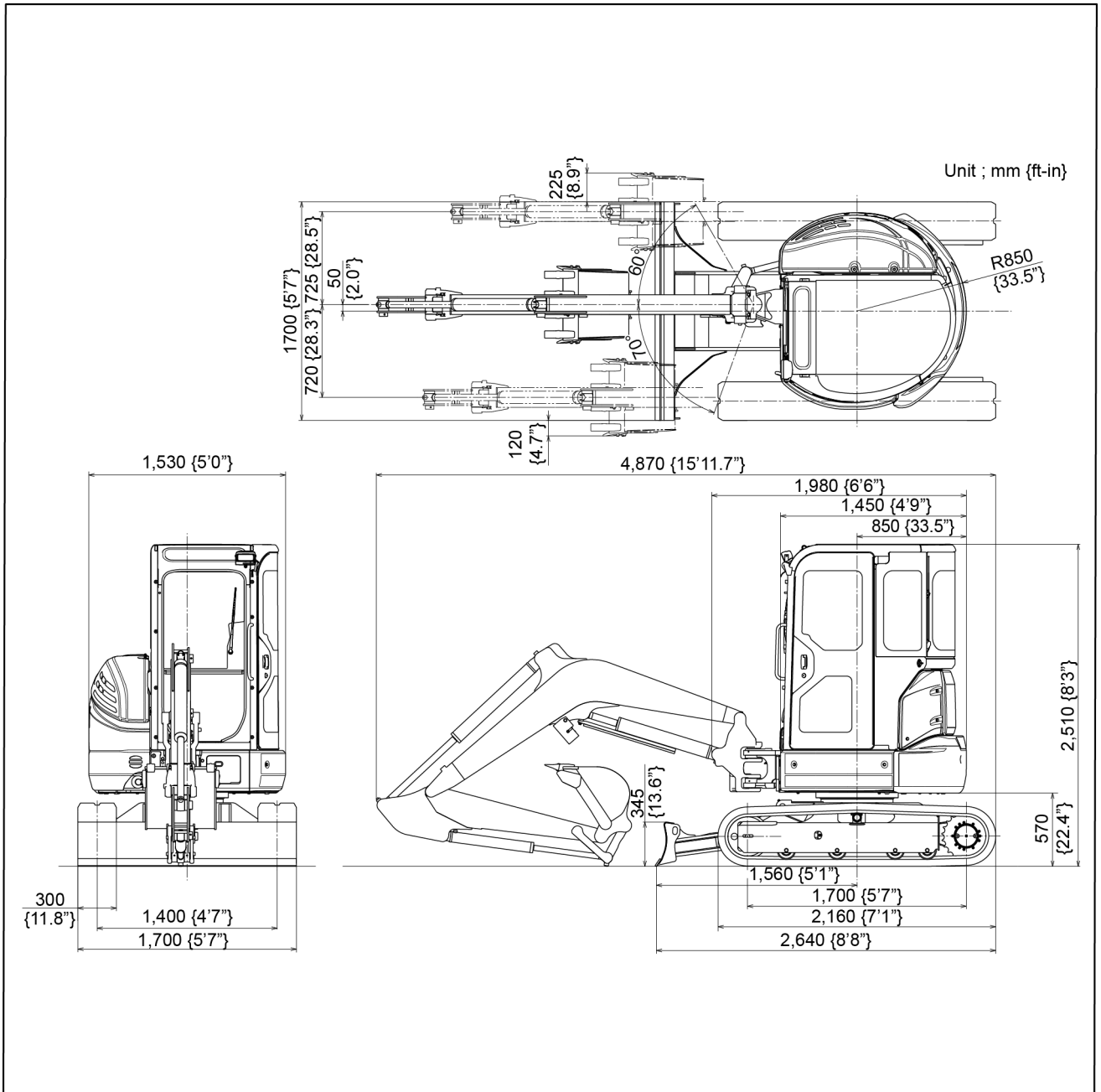

RAIL14CEX1745GA 2

Machine completion - General specification Specifications and performance

CX36B

Speed and gradeability

	Canopy				Cab			
	Rubber shoe		Iron track		Rubber shoe		Iron track	
Swing speed								
Travel speed	Low (1st)	High (2nd)	Low (1st)	High (2nd)	Low (1st)	High (2nd)	Low (1st)	High (2nd)
	2.5 km/h (1.6 mph)	4.4 km/h (2.7 mph)	2.5 km/h (1.6 mph)	4.2 km/h (2.6 mph)	2.5 km/h (1.6 mph)	4.4 km/h (2.7 mph)	2.5 km/h (1.6 mph)	4.2 km/h (2.6 mph)

Gradeability % (degree)	58(30)
-------------------------	--------

Engine

Type	Water cooled, 4-cycle type swirl chamber type diesel engine
Number of cylinders - Bore X Stroke	3 - 82 dia. mm X 84 mm (3.23 in. X 3.31 in.)
Total displacement	1.3310 L (81.2226 in³)
Output rating	17.1 kW at 2400 RPM 23.3 Hp at 2400 RPM
Maximum torque	77.1 N·m at 1440 RPM 57.3 lb ft at 1440 RPM
Starting motor	12 V X 1.7 kW
Alternator	12 V X 55 A

Hydraulic components

Hydraulic pump	Variable displacement axial piston and gear pump
Hydraulic motor	Axial piston
Hydraulic motor with reducer (Travel)	2-Axial piston, 2-Speed motor
Control valve	10-spool multiple control valve
Cylinder (Boom, Arm, Boom swing, Bucket, and Dozer)	Double action cylinder
Return filter	Filter type $\beta_{10} \geq 8 \mu$

Side digging and dozer

Type	Boom swing by hydraulic cylinder	
Boom swing angle	Right	60 °
	Left	70 °
Stroke of the dozer — above/below		395.0 mm (15.6 in)
		320.0 mm (12.6 in)

Mass

Machine mass	Canopy		Cab	
	Rubber shoe	Iron shoe	Rubber shoe	Iron shoe
	3630.0 kg (8002.8 lb)	3720.0 kg (8201.2 lb)	3780.0 kg (8333.5 lb)	3870.0 kg (8531.9 lb)
Upper swing body	2055 kg (4530 lb)		2220 kg (4900 lb)	
Travel system	1210.0 kg (2667.6 lb)	1300.0 kg (2866.0 lb)	1210.0 kg (2667.6 lb)	1300.0 kg (2866.0 lb)
Attachment (Boom + standard arm + standard bucket)	465 kg (1030 lb)			
Oil & water	80 kg (175 lb)			

Machine completion - Weight Machine and components mass (Dry weight)

CX36B

	Rubber shoe		Steel shoe	
	Canopy	Cab	Canopy	Cab
Complete machine	3630.0 kg (8002.8 lb)	3780.0 kg (8333.5 lb)	3720.0 kg (8201.2 lb)	3870.0 kg (8531.9 lb)
Upper frame assembly	2055.0 kg (4530.5 lb)	2220.0 kg (4894.3 lb)	2055.0 kg (4530.5 lb)	2220.0 kg (4894.3 lb)
Upper frame	410.0 kg (903.9 lb)			

Machine completion and equipment - Machine completion

Canopy/ Cab	73.0 kg (160.9 lb)	216.0 kg (476.2 lb)	73.0 kg (160.9 lb)	216.0 kg (476.2 lb)
Engine	150.0 kg (330.7 lb)			
Hydraulic pump	21.0 kg (46.3 lb)			
Radiator	3.0 kg (6.6 lb)			
Hydraulic tank	30.0 kg (66.1 lb)			
Fuel tank	4.0 kg (8.8 lb)			
Boom swing bracket	77.0 kg (169.8 lb)			
Boom swing cylinder	30.0 kg (66.1 lb)			
Swing motor	35.0 kg (77.2 lb)			
Control valve	25.0 kg (55.1 lb)			
Counter weight	665.0 kg (1466.1 lb)			
Guard - Bonnet	87.0 kg (191.8 lb)			
Boom cylinder	40.0 kg (88.2 lb)			
Lower frame assembly	1210.0 kg (2667.6 lb)		1300.0 kg (2866.0 lb)	
Lower frame	375.0 kg (826.7 lb)			
Swing bearing	43.0 kg (94.8 lb)			
Travel motor	36.0 kg (79.4 lb) x 2			
Lower roller	9.0 kg (19.8 lb) x 8			
Front idler	24.0 kg (52.9 lb) x 2			
Idler adjuster	14.0 kg (30.9 lb) x 2			
Sprocket	11.0 kg (24.3 lb) x 2			
300.0 mm (11.8 in) Rubber crawler shoe	146.0 kg (321.9 lb) x 2			
Steel shoe			192.0 kg (423.3 lb) x 2	
Swivel joint	22.0 kg (48.5 lb)			
Dozer	175.0 kg (385.8 lb)			
Dozer cylinder	23.0 kg (50.7 lb)			
Attachment assembly	465.0 kg (1025.1 lb)			
Boom assembly	248.0 kg (546.7 lb)			
Boom	141.0 kg (310.9 lb)			
Arm cylinder	39.0 kg (86.0 lb)			
Arm assembly	134.0 kg (295.4 lb)			
Arm	74.0 kg (163.1 lb)			
Bucket cylinder	23.0 kg (50.7 lb)			
Bucket link	10.0 kg (22.0 lb)			
Idler link	4.0 kg (8.8 lb) x 2			
Stand bucket assembly	83.0 kg (183.0 lb)			
	Rubber shoe		Steel shoe	
	Canopy	Cab	Canopy	Cab
Fluids	80.0 kg (176.4 lb)			
Hydraulic oil	40.0 kg (88.2 lb)			
Fuel	35.0 kg (77.2 lb)			
Coolant	5.0 kg (11.0 lb)			

Index

Machine completion and equipment - 05

Machine completion - 102

Machine completion - General specification	3
Machine completion - General specification Bucket	11
Machine completion - General specification Crawler shoes	11
Machine completion - General specification Machine dimensions	5
Machine completion - General specification Machine dimensions (*)	11
Machine completion - General specification Specifications and performance	6
Machine completion - General specification Specifications and performance (*)	13
Machine completion - General specification Transportation	8
Machine completion - Weight Machine and components mass (Dry weight)	7
Machine completion - Weight Machine and components mass (Dry weight) (*)	14

(*) See content for specific models



PRINTED IN U.S.A.

© 2014 CNH Industrial America LLC.

All rights reserved. No part of the text or illustrations of this publication may be reproduced.

CASE CONSTRUCTION policy is one of continuous improvement and the right to change prices, specification or equipment at any time without notices is reserved.

All data given in this publication is subject to production variations. Dimensions and weight are approximate only and the illustrations do not necessarily show products in standard condition. For exact information about any particular product, please consult your CASE CONSTRUCTION Dealer.



SERVICE MANUAL

Engine

**CX36B Cab TIER 4B (FINAL)
CX36B Canopy TIER 4B (FINAL)**

Contents

Engine - 10

[10.202] Air cleaners and lines	10.1
[10.216] Fuel tanks	10.2
[10.254] Intake and exhaust manifolds and muffler	10.3
[10.400] Engine cooling system	10.4



Engine - 10

Air cleaners and lines - 202

**CX36B Cab TIER 4B (FINAL)
CX36B Canopy TIER 4B (FINAL)**

Contents

Engine - 10

Air cleaners and lines - 202

SERVICE

Air cleaner	
Remove	3
Install	4

Air cleaner - Remove

Tools required	
Flat-head screwdriver	Wrench: 13 mm

1. Loosen clips **(7)** and **(5)**.
2. Remove air hoses **(6)** and **(8)**.
3. Loosen two bolts **(2)** (M8 x 20) and remove air cleaner **(4)** and bracket **(3)** assembly.
4. Loosen four bolts **(1)** (M8 x 16) and remove air cleaner assembly **(4)**.

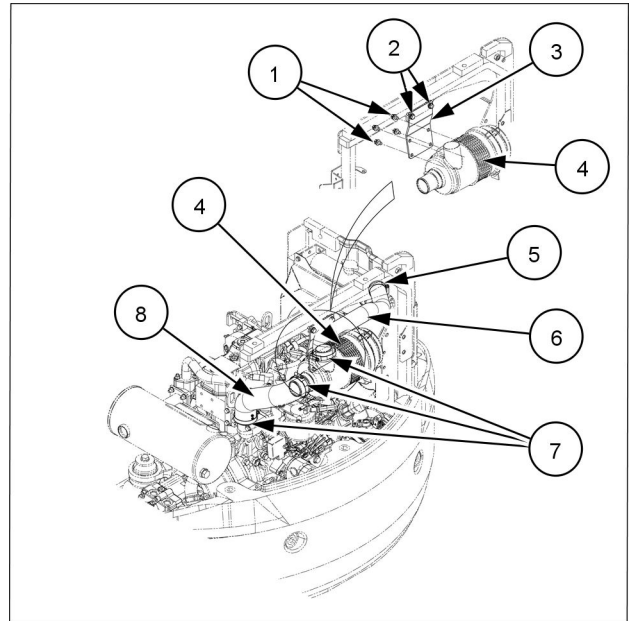

RAIL14CEX1353GA 1

Air cleaner - Install

Tools required

Flat-head screwdriver

Wrench: 13 mm

1. Secure the air cleaner assembly (4) to the bracket (3) using two bolts (2). Tighten the bolts to **23.5 N·m (17.3 lb ft)**.

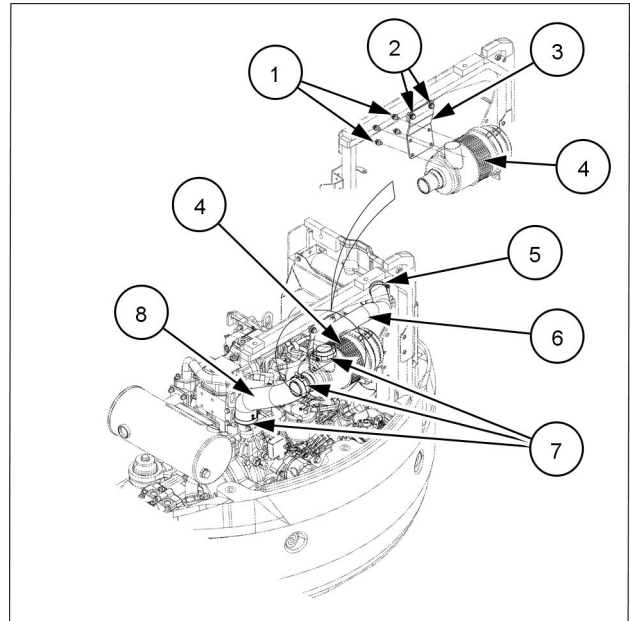

RAIL14CEX1353GA 1

2. Fasten the air cleaner assembly to the frame using four bolts (1). Torque the bolts to **17.7 N·m (13.1 lb ft)**.
3. Install air hoses (6) and (8) using clips (7) and (5).

Index

Engine - 10

Air cleaners and lines - 202

Air cleaner - Install	4
Air cleaner - Remove	3



Engine - 10

Fuel tanks - 216

**CX36B Cab TIER 4B (FINAL)
CX36B Canopy TIER 4B (FINAL)**

This as a preview PDF file from best-manuals.com



Download full PDF manual at best-manuals.com