



# Bobcat®

---

## Operation & Maintenance Manual T180 Compact Track Loader

---

S/N 531460001 & Above  
S/N 531560001 & Above

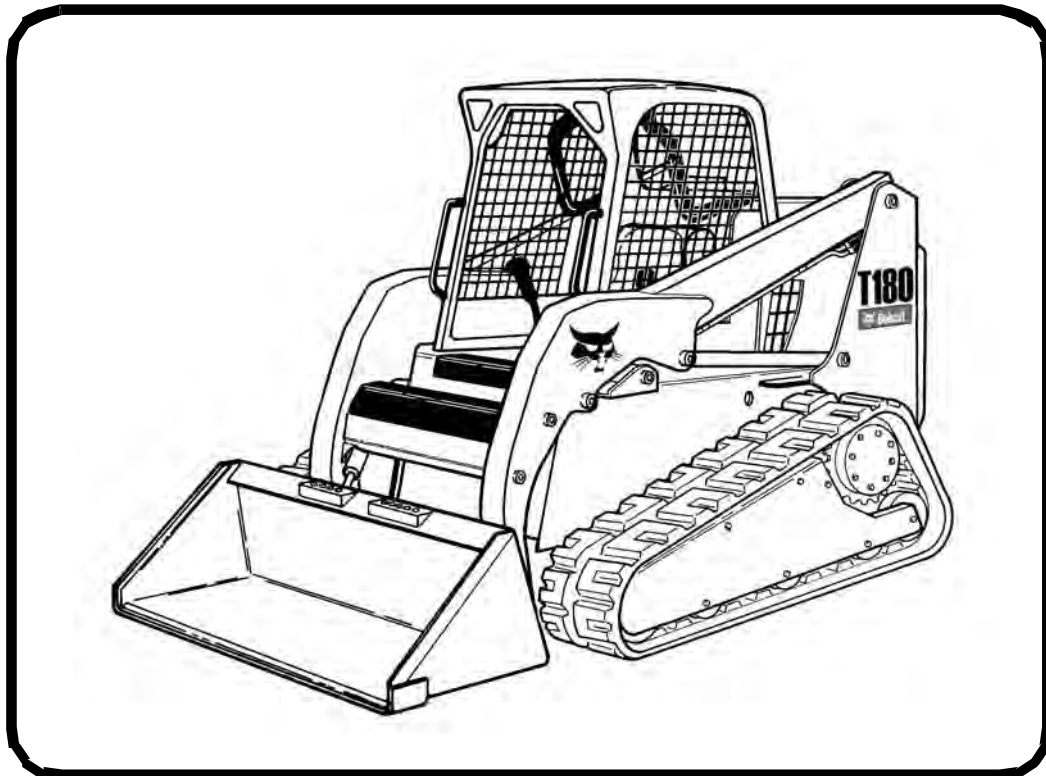

**EQUIPPED WITH  
BOBCAT INTERLOCK  
CONTROL SYSTEM (BICS™)**

*Doosan purchased Bobcat Company from Ingersoll-Rand Company in 2007. Any reference to Ingersoll-Rand Company or use of trademarks, service marks, logos, or other proprietary identifying marks belonging to Ingersoll-Rand Company in this manual is historical or nominative in nature, and is not meant to suggest a current affiliation between Ingersoll-Rand Company and Bobcat Company or the products of either.*





# OPERATOR SAFETY WARNINGS



## WARNING

Operator must have instructions before running the machine. Untrained operators can cause injury or death.

W-2001-1285



**Safety Alert Symbol:** This symbol with a warning statement, means: "Warning, be alert! Your safety is involved!" Carefully read the message that follows.

## CORRECT

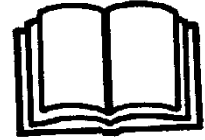

B-10731a



Never use the loader without instructions. See machine signs (decals), Operation & Maintenance Manual, and Operator's Handbook.

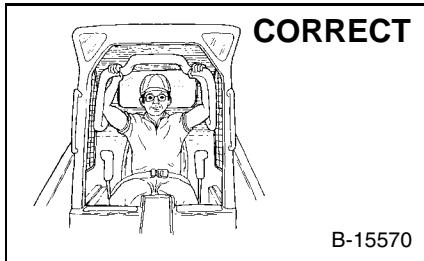

## CORRECT

B-15570



Always use the seat bar and fasten seat belt snugly.



Always keep feet on the foot pedals or footrests when operating loader.

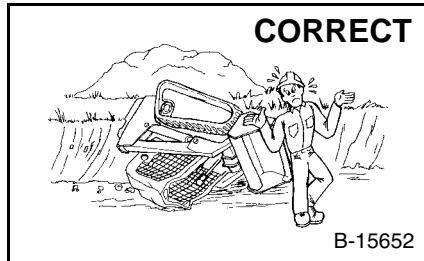

## CORRECT

B-15652



Never use loader without operator cab with ROPS and FOPS approval. Fasten your seat belt.

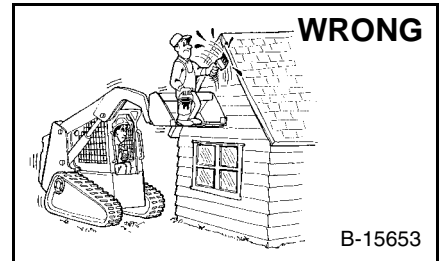

## WRONG

B-15653



Never use loader as man lift or elevating device for personnel.

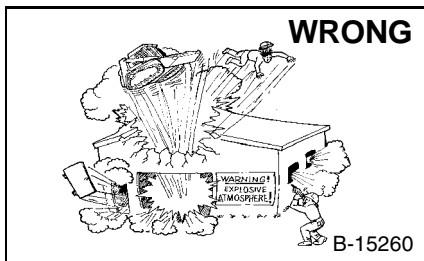

## WRONG

B-15260



Do not use loader in atmosphere with explosive dust, explosive gas, or where exhaust can contact flammable material.

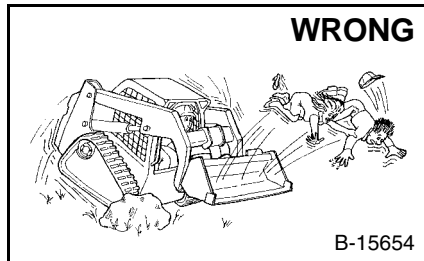

## WRONG

B-15654



Never carry riders.



Keep bystanders away from work area.

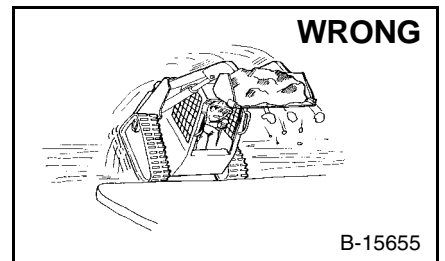

## WRONG

B-15655



Always carry bucket or attachments as low as possible.



Do not travel or turn with lift arms up.



Load, unload, and turn on flat level ground.

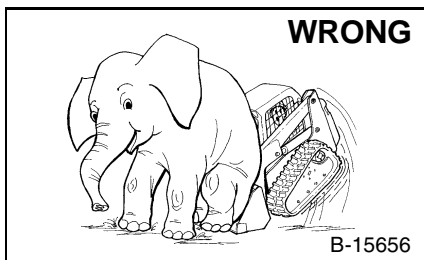

## WRONG

B-15656



Never exceed Rated Operating Capacity.

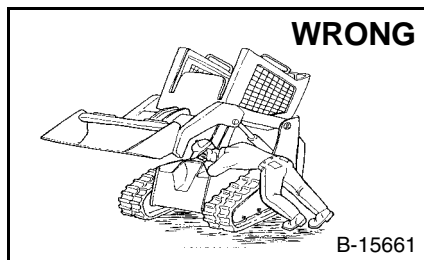

## WRONG

B-15661



Never leave loader with engine running or with lift arms up.



To park, engage parking brake and put attachment flat on the ground.

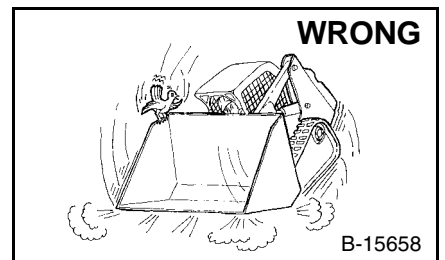

## WRONG

B-15658



Never modify equipment.



Use only attachments approved by Bobcat Company for this model loader.

## SAFETY EQUIPMENT

The Bobcat Loader must be equipped with safety items necessary for each job. Ask your dealer for information on the safe use of attachments and accessories.

1. SEAT BELT: Check belt fasteners and check for damaged webbing or buckle.
2. SEAT BAR: When up, it must lock the loader controls.
3. OPERATOR CAB (ROPS and FOPS): It must be on the loader with all fasteners tight.
4. HANDBOOK: Must be in the cab.
5. SAFETY SIGNS (DECALS): Replace if damaged.
6. SAFETY TREADS: Replace if damaged.
7. GRAB HANDLES: Replace if damaged.
8. LIFT ARM SUPPORT DEVICE: Replace if damaged.
9. PARKING BRAKE
10. BOBCAT INTERLOCK CONTROL SYSTEM (BICS)



**Bobcat®**

# CONTENTS

FOREWORD..... III  
SAFETY & TRAINING RESOURCES..... XI  
OPERATING INSTRUCTIONS ..... OI-1  
PREVENTIVE MAINTENANCE ..... PM-1  
SYSTEM SETUP & ANALYSIS..... SA-1  
MACHINE SIGN TRANSLATIONS ..... MST-1  
SPECIFICATIONS..... SPEC-1  
WARRANTY ..... WARRANTY-1  
ALPHABETICAL INDEX ..... INDEX-1

**FOREWORD**

**SAFETY &  
TRAINING  
RESOURCES**

**OPERATING  
INSTRUCTIONS  
(OI)**

**PREVENTIVE  
MAINTENANCE  
(PM)**

**SYSTEM SETUP  
& ANALYSIS  
(SA)**

**MACHINE SIGN  
TRANSLATIONS  
(MST)**

**SPECIFICATIONS  
(SPEC)**

**WARRANTY**

**ALPHABETICAL  
INDEX**

## REFERENCE INFORMATION

Write the correct information for YOUR Bobcat loader in the spaces below. Always use these numbers when referring to your Bobcat loader.

Loader Serial Number \_\_\_\_\_  
Engine Serial Number \_\_\_\_\_  
\_\_\_\_\_

NOTES:

\_\_\_\_\_  
\_\_\_\_\_  
\_\_\_\_\_  
\_\_\_\_\_

YOUR BOBCAT DEALER:

ADDRESS:

PHONE:

Bobcat Company  
P.O. Box 128  
Gwinner, ND 58040-0128

Bobcat Company Europe  
Drève Richelle 167  
B-1410 WATERLOO  
Belgium



**Bobcat®**

This Operation & Maintenance Manual was written to give the owner / operator instructions on the safe operation and maintenance of the Bobcat loader. **READ AND UNDERSTAND THIS OPERATION & MAINTENANCE MANUAL BEFORE OPERATING YOUR BOBCAT LOADER.** If you have any questions, see your Bobcat dealer. This manual may illustrate options and accessories not installed on your loader.

BOBCAT COMPANY IS ISO 9001:2000 CERTIFIED . . . . . V

DELIVERY REPORT . . . . . VI

FEATURES, ACCESSORIES AND ATTACHMENTS . . . . . VIII

    Attachments . . . . . IX

    Buckets Available . . . . . IX

    High-Flow Attachments . . . . . IX

    Options And Accessories . . . . . VIII

    Special Applications Kit . . . . . X

    Special Applications Kit Inspection And Maintenance . . . . . X

    Standard Items . . . . . VIII

LOADER IDENTIFICATION . . . . . VII

REGULAR MAINTENANCE ITEMS . . . . . V

SERIAL NUMBER LOCATIONS . . . . . VI

    Engine Serial Number . . . . . VI

    Loader Serial Number . . . . . VI



**Bobcat®**



**BOBCAT COMPANY IS ISO 9001:2000 CERTIFIED**













**ISO 9001:2000** is an international standard that controls the processes and procedures which we use to design, develop, manufacture and distribute Bobcat products.

British Standards Institute (**BSI**) is the Certified Registrar Bobcat Company chose to assess the Company's compliance with the ISO 9001:2000 standard. The BSI registration certifies that Bobcat's manufacturing facilities in Gwinner and Bismarck, North Dakota (North America), Pontchateau (France), Dobris (Czech Republic) and the Bobcat corporate offices (Gwinner, Bismarck & West Fargo) in North Dakota are in compliance with ISO 9001:2000. Only certified assessors, like BSI, can grant registrations.

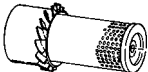
ISO 9001:2000 means that as a company we say what we do and do what we say. In other words, we have established procedures and policies, and we provide evidence that the procedures and policies are followed.

**CALIFORNIA PROPOSITION 65 WARNING**  
 Diesel engine exhaust and some of its constituents are known to the state of California to cause cancer, birth defects and other reproductive harm.

**REGULAR MAINTENANCE ITEMS**

	<b>ENGINE OIL FILTER (6 Pack)</b> 6675517		<b>HYDROSTATIC CASE DRAIN FILTERS</b> 6661022
	<b>FUEL FILTER</b> 6667352		<b>BATTERY</b> 6673865
	<b>AIR FILTER, Outer</b> 6598492		<b>FLUID, Hydraulic / Hydrostatic</b>  6903117 - (2.5 Gal.) 6903118 - (5 Gal.) 6903119 - (55 Gal.)
	<b>AIR FILTER, Inner</b> 6598362		
	<b>HYDRAULIC CHARGE FILTER</b> 6686926		<b>BREATHER CAP</b> 6684923
	<b>HYDROSTATIC FILTER</b> 6661248		<b>ANTI-FREEZE, Propylene Glycol</b>  6983128 - Premixed 6983129 - Concentrate
<b>MOTOR OIL</b>		<b>MOTOR OIL</b>	
6903105	SAE 15W40 CE/SG (12 qt.)	6903106	SAE 15W40 CE/SG (1 Gal.)
6903107	SAE 10W30 CE/SG (12 qt.)	6903108	SAE 10W30 CE/SG (1 Gal.)
6903109	SAE 30W CE/SG (12 qt.)	6903110	SAE 30W CE/SG (1 Gal.)
6903113	SAE 15W40 CE/SG (2.5 Gal.)		
6903112	SAE 10W30 CE/SG (2.5 Gal.)		
6903111	SAE 30W CE/SG (2.5 Gal.)		

**NOTE: Always verify Part Numbers with your Bobcat dealer.**

## SERIAL NUMBER LOCATIONS

Always use the serial number of the loader when requesting service information or when ordering parts. Early or later models (identification made by serial number) may use different parts, or it may be necessary to use a different procedure in doing a specific service operation.

**Figure 1**



### Loader Serial Number

The loader serial number plate [Figure 1] is located on the outside of the loader frame.

Explanation of loader Serial Number:

XXXX XXXXX

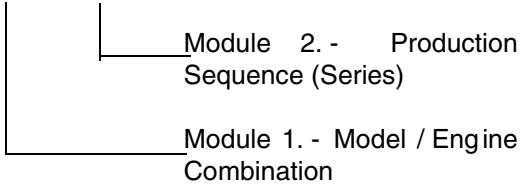

1. The four digit Model / Engine Combination Module number identifies the model number and engine combination.

2. The five digit Production Sequence Number identifies the order which the loader is produced.

## Engine Serial Number

**Figure 2**

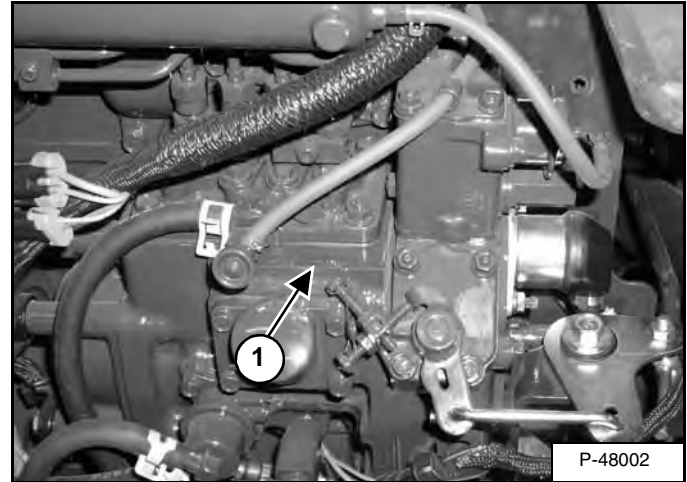

The engine serial number is located on the side of the engine (Item 1) [Figure 2] above the oil filter.

## DELIVERY REPORT

**Figure 3**

The delivery report [Figure 3] must be filled out by the dealer and signed by the owner or operator when the Bobcat loader is delivered. An explanation of the form must be given to the owner. Make sure it is filled out completely.

# LOADER IDENTIFICATION

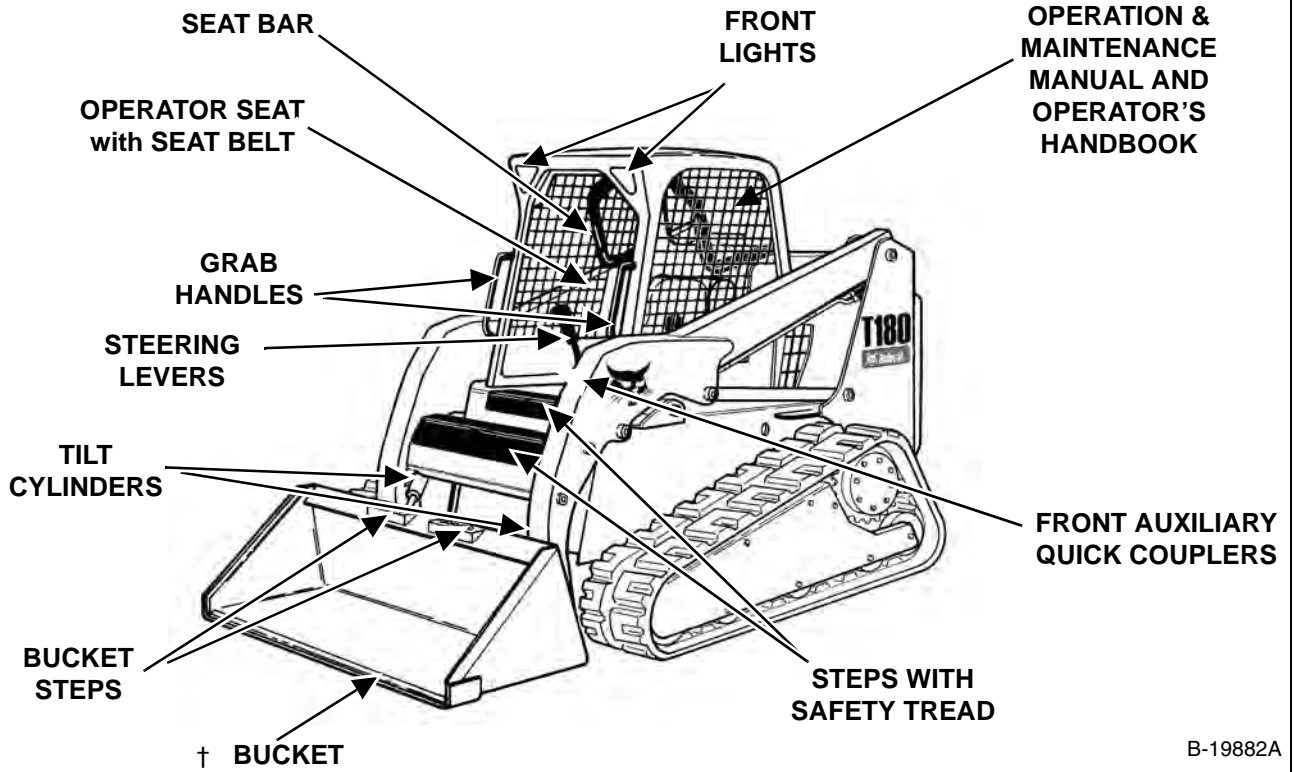

B-19882A

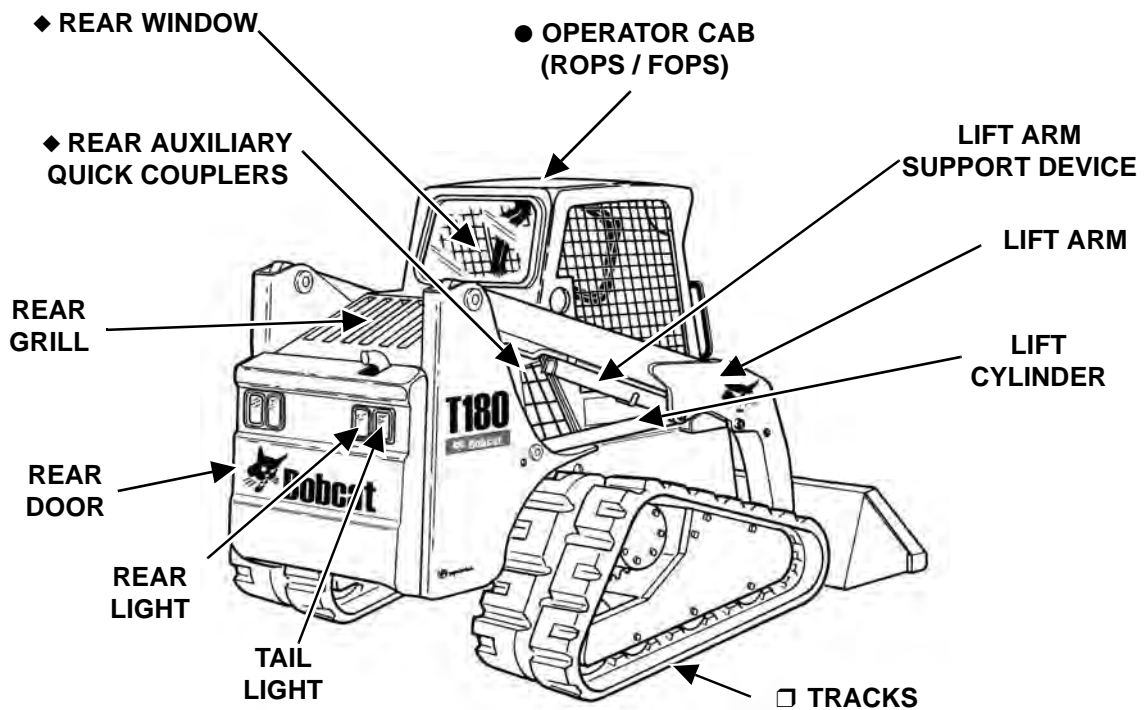

B-19883A

◆ Optional or Field Accessory (Not Standard Equipment)

□ TRACKS - Optional tracks are available.

† Bucket - Several different buckets and other attachments are available for this machine.

● ROPS, FOPS - Roll Over Protective Structure, per ISO 3471, and Falling Object Protective Structure per ISO 3449, Level I. Level II is available.

## FEATURES, ACCESSORIES AND ATTACHMENTS

### Standard Items

Model T180 Bobcat loaders are equipped with the following standard items:

- Adjustable Vinyl Suspension Seat
- Automatically Activated Glow Plugs
- Auxiliary Hydraulics
- Bobcat Interlock Control System (BICS™)
- Bob-Tach
- Deluxe Cab (includes: interior insulation, top and rear windows, accessory harness, dome light and 12 volt power port) ROPS and FOPS Approved
- Engine / Hydraulic Systems Shutdown
- Instrumentation: Hourmeter, Engine Temperature and Fuel Gauges and Warning Lights
- Lift Arm Support Device
- Lights, Front and Rear
- Parking Brake
- Seat Bar
- Seat Belt
- Spark Arrestor Muffler
- Tracks, Rubber - 12.6 inch (320 mm)
- Turbo-Charger

### Options And Accessories

Below is a list of some equipment available from your Bobcat loader dealer as Dealer and / or Factory Installed Accessories and Factory Installed Options. See your Bobcat dealer for other available options and accessories.

- Accessories Electrical Harness
- Advanced Control System (ACS) (Selectable Foot Pedal or Hand Control)
- Selectable Joystick Controls (SJC) (Selectable 'ISO' or 'H' Pattern Control)
- Auxiliary Hydraulics, Rear
- Auxiliary Hydraulics, Front - Right Hand Side
- Air Conditioning
- Attachment Control Device (ACD)
- Back-up Alarm
- Cab Door
- Cab Enclosure
- Cab Heater
- Catalytic Exhaust Purifier
- Deluxe Instrumentation Panel
- Dual Attachment Control Kit
- Dual Steering Dampener Kit
- Engine Heater
- Extended Pedals

### Options And Accessories (Cont'd)

- Fire Extinguisher
- FOPS Kit (Level II)
- GPS System (GlobalTRACS®)
- High-Flow Auxiliary Hydraulics
- Horn
- Hose Guide
- Hydraulic Bucket Positioning (Includes On / Off Selection)
- Lift Kit (4-Point, Single Point)
- Locking Fuel Cap
- Power Bob-Tach
- Radiator Screen Kit
- Radio Remote Control
- Rear Window Wiper
- Ride Control
- Rotating Beacon
- Seat Belt with 3-Point Restraint
- Seat Belt - 3 Inch Wide
- Seat Belt - Retractable
- Sound Cab (Reduces noise at operator ear)
- Sound Insulation (Reduces noise to bystanders)
- Special Applications Kit
- Strobe Light
- Tailgate Lock
- Tool Container
- Tracks:
  - Rubber - 16 inch (400 mm)
  - Winter Rubber - 12.6 inch (320 mm)
- Warning Lights: Four-Way Flasher (Includes Direction Signals)
- Vinyl Cab Enclosure
- Weighlog Kit
- Windows:
  - Top and Rear Windows
  - Side Windows
  - Polycarbonate Rear Window
  - Polycarbonate Top Window
  - Externally Removable Rear Window

***Specifications subject to change without notice.***

## FEATURES, ACCESSORIES AND ATTACHMENTS (CONT'D)

These and other attachments are approved for use on this model loader. Do not use unapproved attachments. Attachments not manufactured by Bobcat may not be approved.

The versatile Bobcat loader quickly turns into a multi-job machine with a tight-fit attachment hook-up . . . from bucket to grapple to pallet fork to backhoe and a variety of other attachments.

See your Bobcat dealer for information about approved attachments and attachment Operation & Maintenance Manuals.

Increase the versatility of your Bobcat loader with a variety of bucket styles and sizes.

## Buckets Available

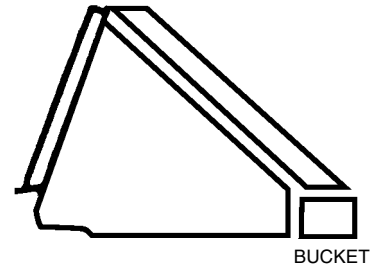

Many bucket styles, widths and different capacities are available for a variety of different applications. They include Construction & Industrial, Low Profile, Fertilizer and Snow, to name a few. See your Bobcat dealer for the correct bucket for your Bobcat loader and application.

---

## Attachments

- Angle Broom
- Auger
- Backhoe
- Blades
  - Box Blade
  - Dozer
  - Snow
  - V-Blade
- Bob-Tach Backhoe
- Breaker, Hydraulic
- Brush Saw
- Buckets
- Chipper
- Combination Bucket
- Concrete Mixer
- Concrete Pump
- Digger
- Drop Hammer
- Dumping Hopper
- Flail Cutter
- Forks, Utility
- Grader
- Grapple, Farm / Utility
- Grapple, Industrial
- Grapple, Root
- Landplane
- Landscape Rake
- Mower
- Packer Wheel
- Pallet Forks
- Planer
- Rear Stabilizers
- Rotary Cutter (Brushcat)
- Scarifier
- Scraper
- Seeder
- Silt Fence Installer
- Snow Pusher
- Snowblower
- Sod Layer
- Soil Conditioner
- Spreader
- Stump Grinder
- Sweeper
- Three-Point Hitch Adapter
- Tiller
- Tree Spade
- Trench Compactor
- Trencher
- Utility Frame
- Vibratory Roller
- Water Kit
- Whisker Broom
- X-Change Frame

## High-Flow Attachments

**The following attachments are approved for use on High-Flow machines. See your Bobcat dealer for an updated list of approved attachments.**

- Angle Broom
- Chipper
- Concrete Pump
- Planer
- Rotary Cutter (Brushcat)
- Snowblower
- Soil Conditioner
- Tiller
- Trencher
- Wheel Saw

## FEATURES, ACCESSORIES AND ATTACHMENTS (CONT'D)

### Special Applications Kit

Figure 4

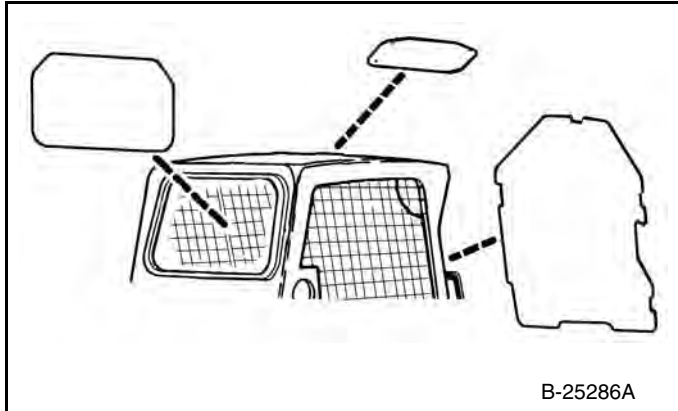

Available for special applications to restrict material from entering cab openings. Kit includes 1/2 inch thick polycarbonate front door, top and rear windows [Figure 4].

See your Bobcat dealer for availability.

### Special Applications Kit Inspection And Maintenance

- Inspect for cracks or damage. Replace if required.
- Pre-rinse with water to remove gritty materials.
- Wash with a mild household detergent and warm water.
- Use a sponge or soft cloth. Rinse well with water and dry with a clean soft cloth or rubber squeegee.
- Do not use abrasive or highly alkaline cleaners.
- Do not clean with metal blades or scrapers.

## SAFETY & TRAINING RESOURCES

### SAFETY & TRAINING RESOURCES

FIRE PREVENTION .....	XV
Electrical .....	XV
Fire Extinguishers .....	XVI
Fueling .....	XVI
Hydraulic System .....	XVI
Maintenance .....	XV
Operation .....	XV
Spark Arrestor Exhaust System .....	XVI
Starting .....	XVI
Welding And Grinding .....	XVI
 MACHINE SIGNS (DECALS) .....	 XVIII
 PUBLICATIONS AND TRAINING RESOURCES .....	 XX
 SAFETY INSTRUCTIONS .....	 XIII
Avoid Silica Dust .....	XV
Before Operation .....	XIII
Safe Operation Is The Operator's Responsibility .....	XIV
Safe Operation Needs A Qualified Operator .....	XIV



**Bobcat®**



## SAFETY INSTRUCTIONS

### Before Operation

Carefully follow the operating and maintenance instructions in this manual.

The Bobcat loader is highly maneuverable and compact. It is rugged and useful under a wide variety of conditions. This presents an operator with hazards associated with off highway, rough terrain applications, common with Bobcat loader usage.

The Bobcat loader has an internal combustion engine with resultant heat and exhaust. All exhaust gases can kill or cause illness so use the Loader with adequate ventilation.

The dealer explains the capabilities and restrictions of the Bobcat loader and attachment for each application. The dealer demonstrates the safe operation according to Bobcat instructional materials, which are also available to operators. The dealer can also identify unsafe modifications or use of unapproved attachments. The attachments and buckets are designed for a Rated Operating Capacity (some have restricted lift heights). They are designed for secure fastening to the Bobcat loader. The user must check with the dealer, or Bobcat literature, to determine safe loads of materials of specified densities for the machine - attachment combination.

The following publications and training materials provide information on the safe use and maintenance of the Bobcat machine and attachments:

- The Delivery Report is used to assure that complete instructions have been given to the new owner and that the machine and attachment is in safe operating condition.
- The Operation & Maintenance Manual delivered with the machine or attachment gives operating information as well as routine maintenance and service procedures. It is a part of the machine and can be stored in a container provided on the machine. Replacement Operation & Maintenance Manuals can be ordered from your Bobcat dealer.
- Machine signs (decals) instruct on the safe operation and care of your Bobcat machine or attachment. The signs and their locations are shown in the Operation & Maintenance Manual. Replacement signs are available from your Bobcat dealer.

- An Operator's Handbook is fastened to the operator cab of the loader. It's brief instructions are convenient to the operator. The Handbook is available from your dealer in an English edition or one of many other languages. See your Bobcat dealer for more information on translated versions.
- The AEM Safety Manual delivered with the machine gives general safety information.
- The Skid-Steer Loader Operating Training Course is available through your Bobcat dealer. This course is intended to provide rules and practices of correct operation of the Bobcat loader. The course is available in English and Spanish versions.
- Service Safety Training Courses are available from your Bobcat dealer. They provide information for safe and correct service procedures.
- See the PUBLICATIONS AND TRAINING RESOURCES Page in this manual or your Bobcat dealer for Service and Parts Manuals, printed materials, videos, or training courses available. Also check the Bobcat web sites [www.training.bobcat.com](http://www.training.bobcat.com) or [www.bobcat.com](http://www.bobcat.com)

The dealer and owner / operator review the recommended uses of the product when delivered. If the owner / operator will be using the machine for a different application(s) he or she must ask the dealer for recommendations on the new use.



**Call Before You Dig**  
**Dial 811 (USA Only)**  
**1-888-258-0808 (USA & Canada)**

When you call, you will be directed to a location in your state / province, or city for information about buried lines (telephone, cable TV, water, sewer, gas, etc.).

SI SSL-0208

## SAFETY INSTRUCTIONS (CONT'D)

### Safe Operation Is The Operator's Responsibility



Operator must have instructions before running the machine. Untrained operators can cause injury or death.

W-2001-1285



This notice identifies procedures which must be followed to avoid damage to the machine.

I-2019-0284



The signal word DANGER on the machine and in the manuals indicates a hazardous situation which, if not avoided, will result in death or serious injury.

D-1002-1107



The signal word WARNING on the machine and in the manuals indicates a potentially hazardous situation which, if not avoided, could result in death or serious injury.

W-2044-1107

The Bobcat loader and attachment must be in good operating condition before use.

Check all of the items on the Bobcat Service Schedule Decal under the 8-10 hour column or as shown in the Operation & Maintenance Manual.

### Safe Operation Needs A Qualified Operator

For an operator to be qualified, he or she must not use drugs or alcoholic drinks which impair alertness or coordination while working. An operator who is taking prescription drugs must get medical advice to determine if he or she can safely operate a machine.

*A Qualified Operator Must Do The Following:*

*Understand the Written Instructions, Rules and Regulations*

- The written instructions from Bobcat Company include the Delivery Report, Operation & Maintenance Manual, Operator's Handbook, Safety Manual and machine signs (decals).
- Check the rules and regulations at your location. The rules may include an employer's work safety requirements. Regulations may apply to local driving requirements or use of a Slow Moving Vehicle (SMV) emblem. Regulations may identify a hazard such as a utility line.

*Have Training with Actual Operation*

- Operator training must consist of a demonstration and verbal instruction. This training is given by your Bobcat dealer before the product is delivered.
- The new operator must start in an area without bystanders and use all the controls until he or she can operate the machine and attachment safely under all conditions of the work area. Always fasten seat belt before operating.
- Operator Training Courses are available from your Bobcat dealer in English and Spanish. They provide information for safe and efficient equipment operation. Safety videos are also available.
- Service Safety Training Courses are available from your Bobcat dealer. They provide information for safe and correct service procedures.

*Know the Work Conditions*

- Know the weight of the materials being handled. Avoid exceeding the Rated Operating Capacity (ROC) of the machine. Material which is very dense will be heavier than the same volume of less dense material. Reduce the size of the load if handling dense material.
- The operator must know any prohibited uses or work areas, for example, he or she needs to know about excessive slopes.
- Know the location of any underground lines. Call local utilities or the TOLL FREE phone number found in the *Before Operation* Section of this manual.
- Wear tight fitting clothing. Always wear safety glasses when doing maintenance or service. Safety glasses, respiratory equipment, hearing protection or Special Applications Kits are required for some work. See your Bobcat dealer about Bobcat Safety Equipment for your model.

SI SSL-0208

## SAFETY INSTRUCTIONS (CONT'D)

### Avoid Silica Dust



Cutting or drilling concrete containing sand or rock containing quartz may result in exposure to silica dust. Do not exceed Permissible Exposure Limits (PEL) to silica dust as determined by OSHA or other job site Rules and Regulations. Use a respirator, water spray or other means to control dust. Silica dust can cause lung disease and is known to the state of California to cause cancer.

## FIRE PREVENTION



### Maintenance

The machine and some attachments have components that are at high temperatures under normal operating conditions. The primary source of high temperatures is the engine and exhaust system. The electrical system, if damaged or incorrectly maintained, can be a source of arcs or sparks.

Flammable debris (leaves, straw, etc.) must be removed regularly. If flammable debris is allowed to accumulate, it can cause a fire hazard. Clean often to avoid this accumulation. Flammable debris in the engine compartment is a potential fire hazard.

The operator's area, engine compartment and engine cooling system must be inspected every day and cleaned if necessary to prevent fire hazards and overheating.

All fuels, most lubricants and some coolants mixtures are flammable. Flammable fluids that are leaking or spilled onto hot surfaces or onto electrical components can cause a fire.

### Operation

Do not use the machine where exhaust, arcs, sparks or hot components can contact flammable material, explosive dust or gases.

### Electrical



Check all electrical wiring and connections for damage. Keep the battery terminals clean and tight. Repair or replace any damaged part or wires that are loose or frayed.

Battery gas can explode and cause serious injury. Use the procedure in the Operation & Maintenance Manual for connecting the battery and for jump starting. Do not jump start or charge a frozen or damaged battery. Keep any open flames or sparks away from batteries. Do not smoke in battery charging area.

SI SSL-0208

## FIRE PREVENTION (CONT'D)

### Hydraulic System

Check hydraulic tubes, hoses and fittings for damage and leakage. Never use open flame or bare skin to check for leaks. Hydraulic tubes and hoses must be properly routed and have adequate support and secure clamps. Tighten or replace any parts that show leakage.

Always clean fluid spills. Do not use gasoline or diesel fuel for cleaning parts. Use commercial nonflammable solvents.

### Fueling



Stop the engine and let it cool before adding fuel. No smoking! Do not refuel a machine near open flames or sparks. Fill the fuel tank outdoors.

### Starting

Do not use ether or starting fluids on any engine that has glow plugs. These starting aids can cause explosion and injure you or bystanders.

Use the procedure in the Operation & Maintenance Manual for connecting the battery and for jump starting.

### Spark Arrestor Exhaust System

The spark arrestor exhaust system is designed to control the emission of hot particles from the engine and exhaust system, but the muffler and the exhaust gases are still hot.

Check the spark arrestor exhaust system regularly to make sure it is maintained and working properly. Use the procedure in the Operation & Maintenance Manual for cleaning the spark arrestor muffler (if equipped).

### Welding And Grinding

Always clean the machine and attachment, disconnect the battery, and disconnect the wiring from the Bobcat controllers before welding. Cover rubber hoses, battery and all other flammable parts. Keep a fire extinguisher near the machine when welding.

Have good ventilation when grinding or welding painted parts. Wear dust mask when grinding painted parts. Toxic dust or gas can be produced.

Dust generated from repairing nonmetallic parts such as hoods, fenders or covers can be flammable or explosive. Repair such components in a well ventilated area away from open flames or sparks.

### Fire Extinguishers

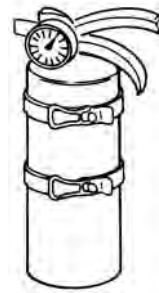

Know where fire extinguishers and first aid kits are located and how to use them. Inspect the fire extinguisher and service the fire extinguisher regularly. Obey the recommendations on the instructions plate.

This as a preview PDF file from [best-manuals.com](http://best-manuals.com)



Download full PDF manual at [best-manuals.com](http://best-manuals.com)