



OPERATOR'S MANUAL

COMPACT CRAWLER EXCAVATOR

CX36B
TIER 4



READ, UNDERSTAND, AND FOLLOW ALL SAFETY PRECAUTIONS AND INSTRUCTIONS FOUND IN THIS MANUAL BEFORE OPERATING THE MACHINE.

CNH America, LLC reserves the right to make improvements in design or changes in specifications at any time without incurring any obligation to install them on units previously sold.

All data given in this publication is subject to production variations. Dimensions and weights are only approximate. Illustrations do not necessarily show products in standard condition. For exact information about any particular product, please consult your Dealer

This unit first became available 01-2008			
REVISION HISTORY			
Issue	Issue Date	Applicable Machines	Remarks
First Edition	01Jan 08	CX36B Tier 4 Compact Crawler Excavator	87722071 NA



THIS SAFETY ALERT SYMBOL INDICATES IMPORTANT SAFETY MESSAGES IN THIS MANUAL. WHEN YOU SEE THIS SYMBOL, CAREFULLY READ THE MESSAGE THAT FOLLOWS AND BE ALERT TO THE POSSIBILITY OF DEATH OR SERIOUS INJURY.

Safety Decals on this machine use the words Danger, Warning, or Caution, which are defined as follows:



- **DANGER:** Indicates an immediate hazardous situation that, if not avoided, will result in death or serious injury.

The color associated with Danger is RED.

- **WARNING:** Indicates a potentially hazardous situation that, if not avoided, could result in death or serious injury. The color associated with Warning is ORANGE.

- **CAUTION:** Indicates a potentially hazardous situation which, if not avoided, may result in minor or moderate injury. It may also be used to alert against unsafe practices. The color associated with Caution is YELLOW.

If Safety Decals on this machine are ISO two panel Pictorial, decals are defined as follows:

- The first panel indicates the nature of the hazard.
- The second panel indicates the appropriate avoidance of the hazard.
- Background color is YELLOW
- Prohibition symbols such as , , and  if used, are RED.

WARNING

IMPROPER OPERATION OF THIS MACHINE CAN CAUSE DEATH OR SERIOUS INJURY. BEFORE USING THIS MACHINE, MAKE CERTAIN THAT EVERY OPERATOR:

- ② Is instructed in safe and proper use of the machine.
- ② Reads and understands the Manual(s) pertaining to the machine.
- ② Reads and understands ALL Safety Decals on the machine.
- ② Clears the area of other persons.
- ② Learns and practices safe use of machine controls in a safe, clear area before operating this machine on a job site.

It is your responsibility to observe pertinent laws and regulations and follow instructions on machine operation and maintenance.

CALIFORNIA PROPOSITION 65 WARNING

Diesel engine exhaust and some of its constituents are known to the State of California to cause cancer, birth defects, and other reproductive harm.

Battery post, terminals and related accessories contain lead and lead compounds. Wash hands after handling.

TECHNICAL MANUALS

Manuals are available from your Dealer for the operation, service, and repair of your machine.

Contact your Dealer for assistance in obtaining the manuals for your machine. Your Dealer can expedite your order for Operator's Manuals, Parts Catalogs, Service Manuals, and maintenance records.

Always give the Machine Name, Model, and P. I. N. (Product Identification Number) or S. N. (Serial Number) of your machine so your Dealer can provide the correct manuals for your machine.

TABLE OF CONTENTS

GENERAL INFORMATION	
To the Owner	1-1
Right, Left, Front, and Rear of the Machine	1-2
Machine Components	1-3
Identification Numbers	1-4
CHAPTER 2	
SAFETY, DECALS, AND HAND SIGNALS	
Table of Contents	2-1
Safety Rules	2-3
Operator Precautions	2-5
Decals	2-10
Cap and Key Cover - Caution	2-22
Stop Engine - Danger	2-22
Hand Signals	2-26
CHAPTER 3	
INSTRUMENTS AND CONTROLS	
Table of Contents	3-1
Operator Cab and Operator Seat	3-3
Machine Access Compartments and Doors	3-7
Operator's Compartment Controls and Accessories	3-8
CHAPTER 4	
OPERATING INSTRUCTIONS	
Table of Contents	4-1
Before Operating the Machine	4-3
Operating the Machine	4-3
Starting and Stopping Machine Engine	4-4
Starting and Stopping Machine Engine in Cold Climates	4-5
Control Decal	4-9
Basic Operation of Hydraulic Controls	4-10
Practices to Improve Efficiency	4-16
Hydraulic Breaker	4-20
Transportation	4-26
Machine Storage	4-30
CHAPTER 5	
LUBRICATION, FILTERS, AND FLUIDS	
Table of Contents	5-1
Fluids and Filters	5-3
Lubricant Specifications	5-5
Use of Bio-Degradable Oils	5-5
CHAPTER 6	
MAINTENANCE AND ADJUSTMENTS	
Table of Contents	6-1
General Information	6-3
General Safety	6-3
Releasing Pressure in the Hydraulic System	6-6
Lubrication and Maintenance Quick Reference Chart	6-8
Daily Inspection and Maintenance	6-10
50 hour maintenance:	6-17
250 Hour Maintenance	6-25
500 Hour Maintenance	6-30

1000 Hour Maintenance	6-34
1500 Hour Maintenance	6-37
2000 Hour Maintenance	6-38
5000 Hour Maintenance	6-47
Special Procedures	6-48

CHAPTER 7

ELECTRICAL

Table of Contents	7-1
-------------------------	-----

CHAPTER 8

SPECIFICATIONS

Table of Contents	8-1
General Specifications	8-3
Lifting Capacities	8-10
Torque Specifications	8-11

CHAPTER 9

INDEX

GENERAL INFORMATION

TO THE OWNER

CX36B COMPACT CRAWLER EXCAVATOR - TIER 4

Your machine has been designed and built to the highest standards of quality. It conforms to all current safety regulations. The risk of accidents can never be completely excluded. That is why it is essential to observe elementary safety rules and precautions.

Read this manual carefully, paying particular attention to the instructions concerning safety, operation and maintenance so as to avoid the risk of injury while operating or servicing the machine.

The standard attachments and tools of this machine are designed to carry out all kinds of earth moving and rehandling operations. If you want to use this machine to handle a load (pipes, culverts, formwork, etc.), make sure that it is equipped to carry out this kind of work. For this type of application, the machine must be equipped with safety valves, a load handling chart corresponding to the type of machine and its attachment and a load fixing point. All legal requirements must also be strictly observed.

Do not use this machine for any application or purpose other than those described in this manual. If the machine is to be used for work involving the use of special attachments, accessories or equipment, consult your Case Dealer in order to make sure that any adaptations or modifications made are in keeping with the machine's technical specifications and with prevailing safety requirements.

Any modification or adaptation which is not approved by the manufacturer may invalidate the machine's initial conformity with safety requirements.

The machine must undergo regular inspections, the frequency of which varies according to the type of use. Consult your authorized Case Dealer.

Before permitting a new operator on this machine, make sure:

That the operator has received the necessary training on how to operate the machine correctly and safely.

That the operator has read and understood the instructions given in this manual.

Contact your dealer for operator manuals translated into Spanish or French Canadian.

Always keep this manual in the operator's compartment (in the seat back, behind the operator's seat). Make sure it is complete and in good condition. If you wish to obtain extra copies, or copies in languages other than that of the country of use, consult your authorized Case Dealer.

Your Case Dealer is available for any further information. They will also provide any after-sales service you may need, and genuine Case spare parts, your guarantee of quality and match.

RIGHT, LEFT, FRONT, AND REAR OF THE MACHINE

The terms **Right-hand**, **Left-hand**, **Front**, and **Rear** are used in this manual to indicate the sides as they are seen from the operator's seat when the cab is over the idler wheels.

The following illustration shows the machine in normal **TRAVEL** position. In normal **TRAVEL** position, the cab is over the idler wheels. The travel reduction gears are at the rear of the upper structure.

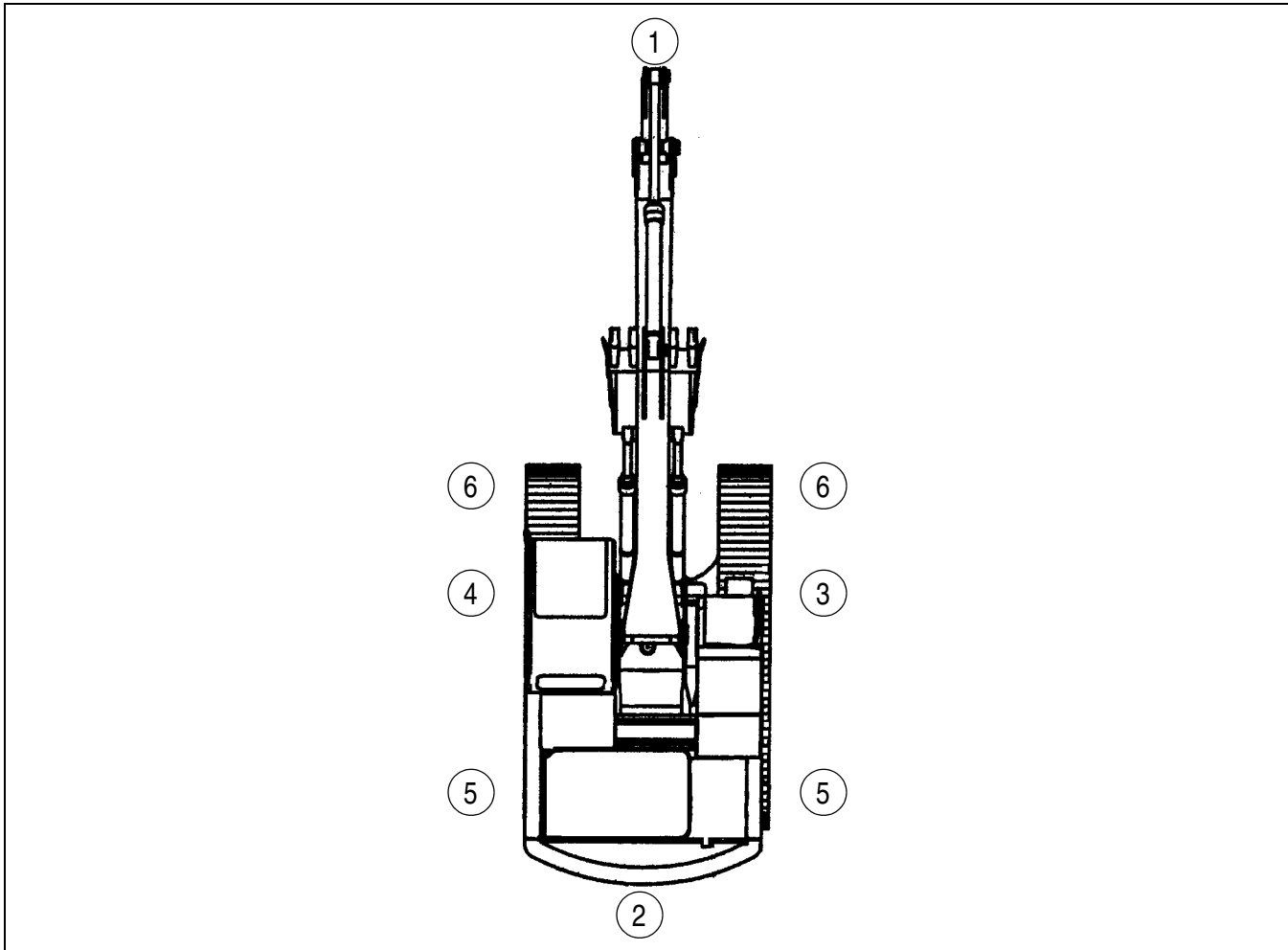

DC03H142

Figure 1

1. FRONT
2. REAR

3. RIGHT HAND SIDE
4. LEFT HAND SIDE

5. TRAVEL REDUCTION GEARS (TRAVEL MOTORS)
6. IDLER WHEELS

MACHINE COMPONENTS

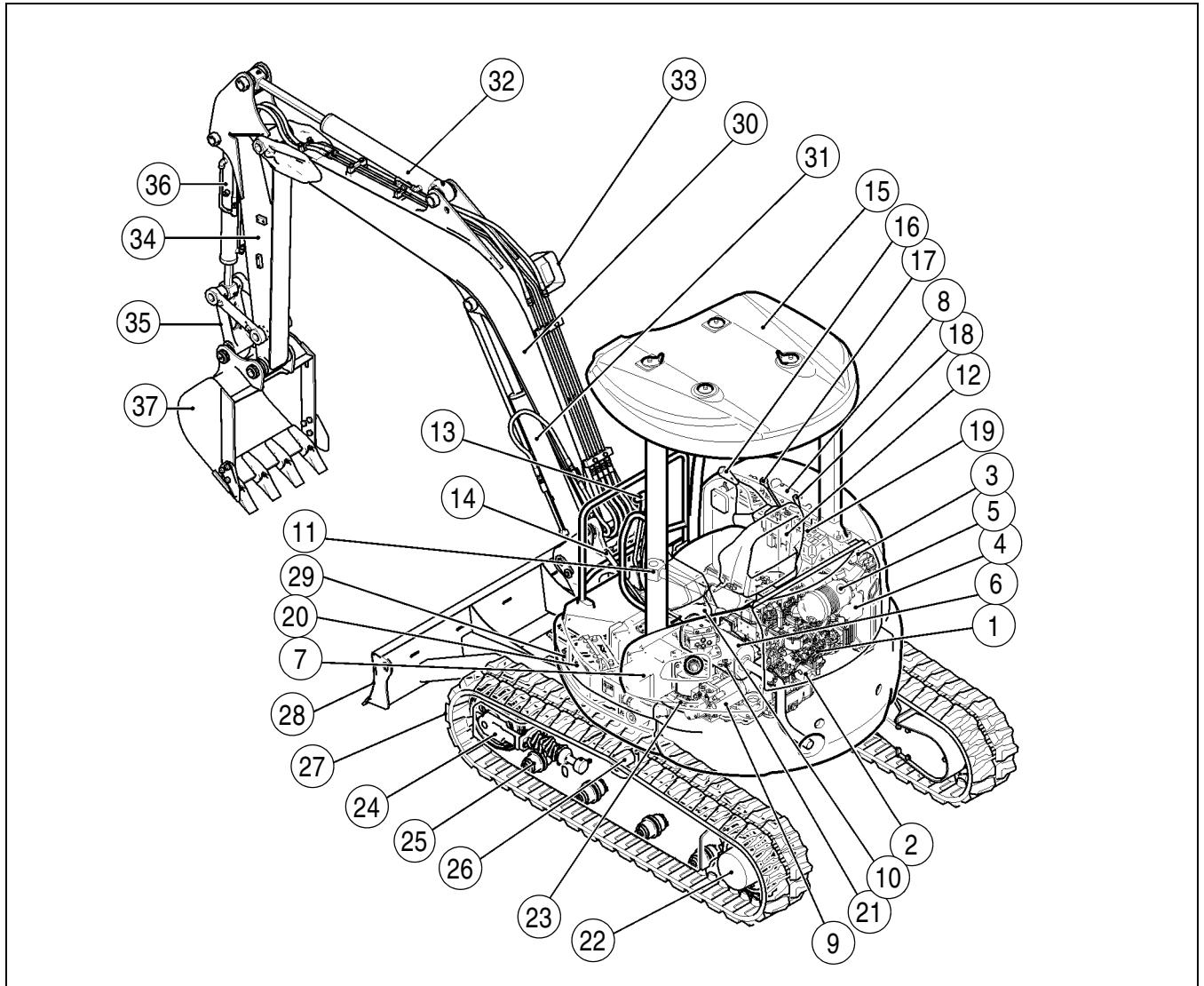

BS07M601

Figure 2

MACHINE COMPONENTS

- | | | | |
|-------------------|-------------------------|-------------------------|---------------------|
| 1. ENGINE | 11. SWING CYLINDER | 21. SWIVEL JOINT | 31. BOOM CYLINDER |
| 2. OIL FILTER | 12. CONTROL VALVE | 22. TRAVEL MOTOR | 32. ARM CYLINDER |
| 3. RADIATOR | 13. TRAVEL LEVER | 23. SWING BEARING | 33. WORK LAMP |
| 4. RESERVOIR TANK | 14. SAFETY LOCK LEVER | 24. IDLER ASSEMBLY | 34. ARM |
| 5. AIR CLEANER | 15. CANOPY | 25. LOWER ROLLER | 35. LINK |
| 6. MUFFLER | 16. CONTROL LEVER | 26. UPPER ROLLER | 36. BUCKET CYLINDER |
| 7. FUEL TANK | 17. DOZER CONTROL LEVER | 27. RUBBER CRAWLER BELT | 37. BUCKET |
| 8. HYDRAULIC TANK | 18. THROTTLE LEVER | 28. DOZER BLADE | |
| 9. HYDRAULIC PUMP | 19. MONITOR PANEL | 29. DOZER CYLINDER | |
| 10. SWING MOTOR | 20. BATTERY | 30. BOOM | |

IDENTIFICATION NUMBERS

MODEL, SERIAL NUMBER, AND YEAR OF MANUFACTURE

When ordering parts, obtaining information or assistance, always supply your Case Dealer with the type and serial number of your machine or accessories.

Write the following in the spaces below: The type, serial number and year of manufacture of your machine, accessories and the serial numbers of the various hydraulic and mechanical components.

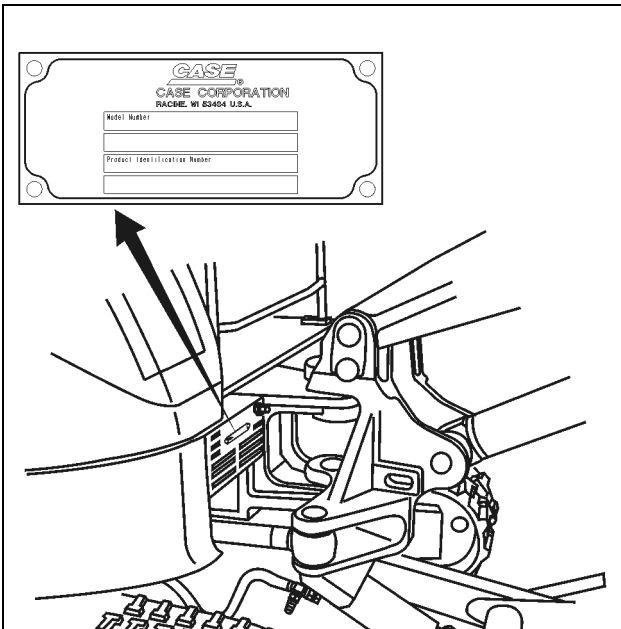

BS07N400

Figure 3

PRODUCT IDENTIFICATION PLATE	
➤ _____	Model
➤ _____	Serial Number
➤ _____	Manufacturing Year

ENGINE

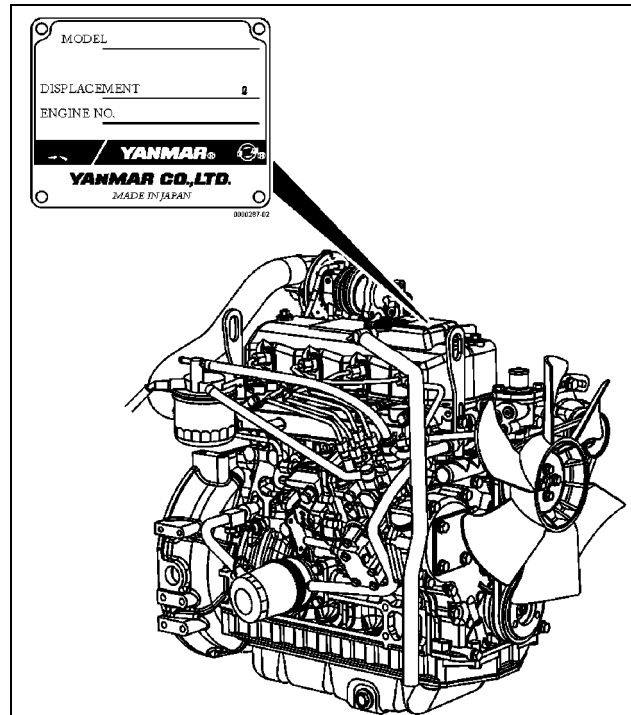

BS07M603

Figure 4

ENGINE	
➤ _____	Make and Model
➤ _____	Serial Number

COMPONENT SERIAL NUMBERS

COMPONENT SERIAL NUMBERS	
➤ _____	Hydraulic Pump
➤ _____	Swing Reduction Gear
➤ _____	Travel Reduction Gears
➤ _____	Travel Control Valve
➤ _____	Attachment Control Valve
➤ _____	Swing Control Valve

CHAPTER 2
SAFETY, DECALS, AND HAND SIGNALS
TABLE OF CONTENTS

SAFETY RULES	2-3
Personal Safety	2-3
Safety Area	2-3
Utility Safety	2-4
OPERATOR PRECAUTIONS	2-5
Personnel	2-5
General	2-5
Mounting and Dismounting Precautions	2-5
Starting and Stopping Precautions	2-5
Operating Precautions	2-6
Maintenance Precautions	2-7
Fuel Handling Precautions	2-8
Burn Prevention	2-8
Hazardous Chemical Precautions	2-8
Transporting Precautions	2-8
Roll-Over Protective Structure (If equipped)	2-8
Fire Extinguisher	2-8
Fire Prevention	2-8
Seat Belt Precautions	2-9
Emergency Exit Hammer	2-9
Specific Precautions to this Machine	2-9
DECALS	2-10
Boom and Arm Movement - Caution	2-11
Hydraulic Oil - Warning	2-11
Safety Controls - Warning	2-12
Hot Surfaces - Caution	2-12
Pressurized Fluids and Lubricants - Warning	2-13
Engine Stop - Caution	2-13
Counterweight Swing Area - Danger	2-14
Engine Stop - Caution	2-14
Booster Cable - Warning	2-15
track Tension Adjuster - Warning	2-15
Keep Clear of Working Area - Danger	2-16
Battery - Danger	2-17
Selector Valve - Caution	2-18
Safety Lock Lever - Warning	2-18
Seat Belt - Warning	2-19
Falling Front Window - Caution	2-20
Hydraulic Oil Check Position - Notice	2-21
Stop Engine - Danger	2-22
Confirm Attachment Movement- Warning	2-22
Do Not Operate This Machine- Warning	2-23
California Proposition 65 - Warning	2-23
HAND SIGNALS	2-24
Raise Load Vertically	2-24
Lower Load Vertically	2-24
Move Load In Horizontally	2-24
Move Load Out Horizontally	2-24
Raise Boom	2-24
Lower Boom	2-25
Swing Left	2-25

Swing Right	2-25
Arm In	2-25
Arm Out	2-25
Counter Rotate Left	2-25
Counter Rotate Right	2-26
Travel Forward.	2-26
Travel Reverse	2-26
Close Bucket (Bucket In Or Dig)	2-26
Open Bucket (Bucket Out Or Dump)	2-26
Turn Left	2-26
Turn Right	2-27
Move This Much	2-27
Move Slowly	2-27
Stop	2-27
Emergency Stop	2-27
Stop Engine	2-27

SAFETY RULES

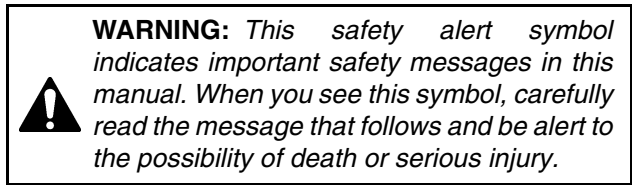

M171C

Most accidents involving machine operating and maintenance can be avoided by following basic safety rules and precautions. Read and understand all the safety messages in this manual, the safety manual and the safety signs on the machine before you operate or service the machine. See your dealer if you have any questions.

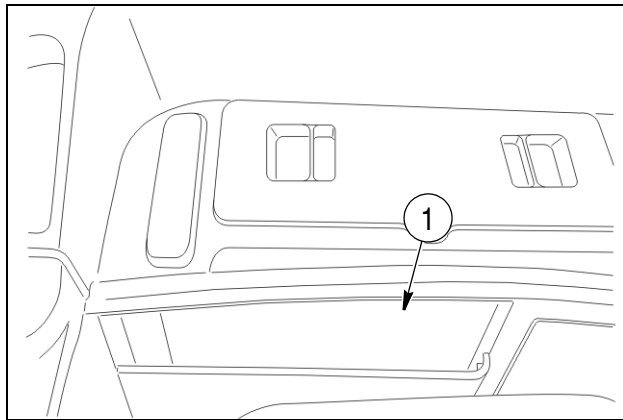

BS06H091

Figure 1

1. OPERATOR'S MANUAL STORAGE SPACE

READ THIS MANUAL COMPLETELY and make sure you understand the controls. All equipment has a limit. Make sure you understand the speed, brakes, steering, stability, and load characteristics of this machine before you start to operate this machine.

DO NOT remove this manual or the safety manual from the machine. See your dealer for additional manuals. Also see the manual information on the Title pages (first and second pages in front of the Table of Contents) of this manual.

The safety information given in this manual does not replace safety codes, insurance needs, federal, state, or local laws. Make sure that your machine has the correct equipment according to these rules or laws.



Additional safety messages are used in the text of the manual to show specific safety hazards.

IMPORTANT: *The safety messages in this chapter point out conditions which can happen during the normal operation and maintenance of your machine. These safety messages also give possible ways of dealing with these conditions.*

PERSONAL SAFETY

If Safety Decals on this machine are ISO two panel Pictorial, decals are defined as follows:

- The first panel indicates the nature of the hazard.
- The second panel indicates the appropriate avoidance of the hazard.
- Background color is YELLOW

Prohibition symbols such as   and  if used, are RED.

SAFETY AREA

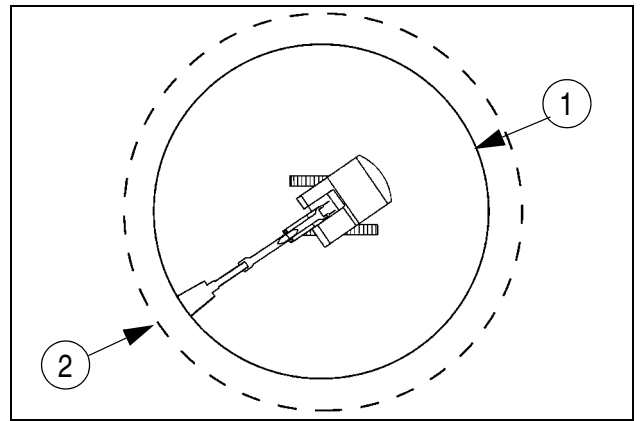

BC02N198

Figure 2

1. WORKING AREA
2. SAFETY AREA

The safety area is the space necessary for the machine to operate at the maximum range of the tool. The area is a full 360° swing plus 6 feet (2 meters).

UTILITY SAFETY

Safety precautions **MUST** be followed when working near buried and overhead Utility Lines.

During operation it is likely that you will be working around or near buried or overhead utility lines which may include, but are not limited to:

- Electrical Power Line
- Gas Line
- Water Line
- Communication Line - Telephone or Cable Television
- Telephone or Cable Television

IMPORTANT: *Before beginning any machine operation, it is your responsibility to be aware of all such utility lines buried and overhead in the area of your project and to avoid them.*

ALWAYS have all local utility companies mark the location of their lines.

In U.S.A. and Canada call one of many “One Call System Director” services. If you do not know the local number, call the national number (U.S.A. and Canada only): 1-888-258-0808.

IMPORTANT: *Check with local authorities for laws, regulations and/or strict penalties requiring you to locate and avoid existing utilities.*

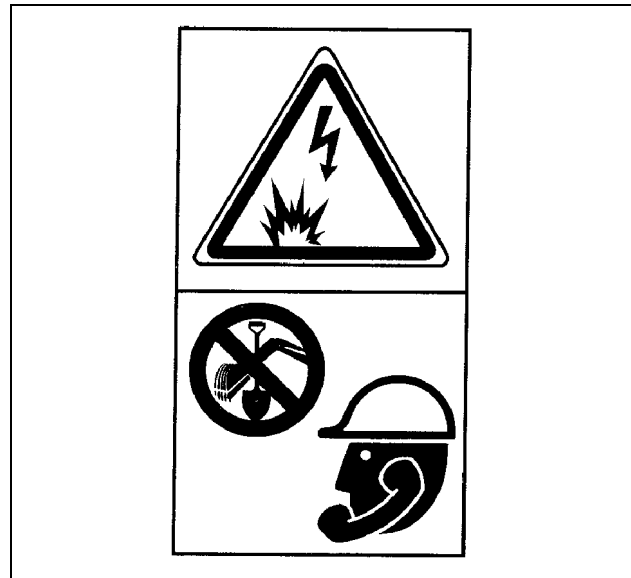

RH99G001

Figure 3

CALL ALL LOCAL UTILITY COMPANIES BEFORE YOU PERFORM ANY MACHINE OPERATION

Know the utility color code (U.S.A. and Canada):

- Electric Red
- Gas, Oil, or Petroleum. Yellow
- Communication, Telephone, Television. . . Orange
- Water Blue
- Sewer Green/Brown
- Proposed Excavation White
- Surveying Pink
- Reclaimed Water and Slurry. Purple

After locating any buried utility lines, carefully dig a hole by hand and/or with automatic vacuum equipment to the utility line to verify the location and depth of the line.

OPERATOR PRECAUTIONS

PERSONNEL

- Be prepared for emergencies. Always have a first aid kit and a working fire extinguisher with you and know how to use each.
- Avoid loose fitting clothing, loose or uncovered long hair, jewelry and loose personal articles.
- Know and use the protective equipment that is to be worn when operating this machine. Hard hats, protective glasses, protective shoes, gloves, reflector type vests, respirators and ear protection are examples of the type of equipment that may be required.
- Certain protective equipment should be replaced and renewed upon age and wear. Old or damaged hard hats may not provide the same level of protection as a new hard hat. Faded and soiled vests are no longer as highly visible as new vests. See the manufacturer's recommendation.
- Do not rush. Walk, do not run.
- Know and use the hand signals required for particular jobs and know who has the responsibility for signaling.

GENERAL

- It is the responsibility of the operator to read and understand the Operator's Manual and other information provided and use the correct operating procedure. Machines should be operated only by qualified operators.
- DO NOT OPERATE this machine or perform maintenance work if you have not had appropriate training and read and fully understand the instructions and warnings in this manual.
- Wear the seat belt to maximize the protection capability of a ROPS (Roll Over Protective Structure) when the machine is so equipped.
- Inspect the ROPS and seat belt mounting bolts on a daily basis to ensure their integrity.
- Do not permit riders on the machine if there is no manufacturer's designated place for a rider.
- DO NOT use the bucket or attachment to lift persons or carry riders on the machine.
- Make sure that all protective guards, canopies, doors, etc. are in place and secure.
- Remove all loose object stored in the machine. Remove all objects which do not belong in or on the machine and its equipment.

MOUNTING AND DISMOUNTING PRECAUTIONS

- Use the hand holds and steps with at least three points of support when getting on and off the machine. Keep steps and platform clean. Face the machine when climbing up and down.
- Do not jump off the machine.
- Do not dismount while the machine is in motion.
- Foreign material or grease on the steps and hand rails can cause an accident. Keep the steps and hand rails clean.

STARTING AND STOPPING PRECAUTIONS

- Walk around the machine and warn all personnel who may be servicing the machine or are in the machine path prior to starting. Do not start until all personnel are clearly away from the machine. Sound the horn, if equipped, before starting.
- Walk around the machine's tool, attachment, or furthest contact point to view operation danger area from the work site personnel view and angle.
- Check that the parking device is applied, place the transmission in neutral or park as specified by the manufacturer before starting the machine.
- Adjust, secure and latch the seat and fasten the seat belt before starting the machine.
- Start and operate the machine only from the operator's seat.
- Do not bypass the machine's neutral-start system. The neutral-start system must be repaired if it malfunctions.
- Use booster cables only in the recommended manner. Improper use can result in battery explosion or unexpected machine motion. Ventilate the battery area before using booster cables. Make sure that using booster cables will not interfere or harm electronic processing or computer devices.
- DO NOT OPERATE the engine in an enclosed area without adequate ventilation.
- Park the machine on level ground whenever possible and apply the parking brake. On grades, park the machine with the wheels or track securely blocked.
- Before leaving the operator's station, lower the equipment to the ground, shut off the engine and place the function cancellation lever into the locked or up position.
- Remove the starter key or disconnect switch when leaving the machine parked or unattended.

OPERATING PRECAUTIONS

- Check brakes, steering and other machine control devices in accordance with the manufacturer's instructions prior to starting operation. Observe all gauges or warning instruments for proper operation. Operate all controls to insure proper operation. If any malfunctions are found, remove the starter key or disconnect switch key. Place a DO NOT OPERATE tag on the machine until the malfunction is corrected.
- If a failure that causes loss of control such as steering, service brakes or engine occurs, stop the machine motion as quickly as possible, remove the starter key or disconnect switch key. Place a DO NOT OPERATE tag on the machine and keep it securely parked until the malfunction is corrected or the machine can be safely towed.
- Understand the machine limitations and keep the machine under control.
- Operate and drive the machine with care and at speed compatible with conditions. Use extra caution when operating over rough ground, on slopes, and when turning.
- Note and avoid all hazards and obstructions such as ditches, underground lines, trees, cliffs, overhead electrical wires or areas where there is danger of a slide.
- Carry loads in recommended positions for maximum stability.
- Never lift loads in excess of capacity.
- Use the recommended machine ballast and counterweighting.
- Know and understand the job site traffic flow patterns and obey signalmen, road signs and flagmen.
- Know and understand that job site conditions may change on an hourly basis. Hills of dirt, debris or obstructions may grow and change from the time you began the day. It is your responsibility to monitor the changes and keep the machine, tools and attachments, etc. a safe distance.
- Watch for bystanders and never allow anyone to be under or to reach through the machine and its equipment while operating.
- Select a gear that will prevent excessive speed when going downhill. Do not coast downhill.
- When roading a machine, know and use the signaling devices required on the machine. Provide an escort for roading where required.
- On machines with independently operated wheel brakes, lock the brake pedals together when roading to provide equalized brake application.
- Use the recommended transport devices when roading the machine.
- Use the approved drawbar and / or attachment point when using the machine for towing. If a cable or chain is used, keep people away from the tow line.
- Before you operate at night, check that all lamps illuminate.
- If your machine has a cab make sure that all windows are clean and that the windshield wipers and washers work correctly.
- Engine exhaust fumes can cause death. If you operate this machine in an enclosed area, make sure there is ventilation to replace the exhaust fumes with fresh air.
- Check all controls in a clear area and make sure the machine is operating correctly.
- Dust, fog, smoke, etc., can decrease your vision and cause an accident. Stop the machine or decrease the speed until you can see.
- Contact with high voltage power lines, underground cables, etc., can cause serious injury or death from electrocution.
- Before you drive or operate in an area with high voltage lines, cables, or a power station, tell the power or utility company what you are going to do. You **MUST HAVE THE POWER DISCONNECTED OR KEEP A SAFE WORKING DISTANCE** from the lines, cables, or power station. Keep all parts of the machine a safe distance away from the power source. You must also know any federal, state/provincial, or local safety codes or regulations that apply to the job site.
- If a part of the machine touches high voltage power:
 1. Warn other workers **NOT TO TOUCH THE MACHINE** and to stay away from the machine.
 2. If you can break contact, reverse the operation that caused contact with the high voltage power, and move the machine away from the danger area. If you cannot break contact stay in the machine until the utility company de-energizes the line and tells you that the power is off.
- If you have extreme conditions, such as a fire, etc., and you are forced to leave the machine, do not step off the machine. Jump as far from the machine as possible with your feet together and do not touch the ground with your hands.

- DO NOT OPERATE the machine if you do not feel well. This can be dangerous for you and for the people around you.
- You must make a judgment if weather, road, or earth conditions will permit safe operation on a hill, ramp, or rough ground.
- Stay away from hazardous areas such as ditches, overhangs, etc. Walk around the work area before you start and look for hazards.
- Be alert and always know the location of all workers in your area. Keep all other persons completely away from your machine. Injury or death can result if you do not follow these instructions.
- Develop fluid and smooth operating techniques and maintain the surface condition where the machine travels in order to control vibration transfer to the operator.

MAINTENANCE PRECAUTIONS

- Do not attempt repairs unless trained. Refer to manuals and experienced repair personnel for help.



DC04E084

Figure 4

- Avoid lubrication or mechanical adjustments with the machine in motion or the engine operating. If the engine must be in operation to make certain adjustments, place the transmission in neutral, apply the parking brake, place the equipment in a safe position, securely block the tracks and use extreme caution.
 - Securely block the machine or any component that may fall before working on the machine or component. If possible, use a back up or secondary blocking device, also.
 - To prevent unexpected movement, securely block working elements when repairing or changing working tool parts such as cutting edges.
 - Never make repairs on pressurized components, fluid, gas or mechanical until the pressure has been relieved according to the manufacturer's instructions.
 - Use extreme caution when removing radiator caps, drain plugs, grease fittings or pressure taps. Park the machine and let it cool down before opening a pressurized tank.
 - Release all pressure before working on systems which have an accumulator. Use a piece of cardboard, newspaper, or wood to check for pressurized leaks to prevent fluid penetrating the skin. Pressurize accumulators with the proper gas according to manufacturer's recommendations.
 - When absolutely necessary to tow the machine, do not exceed the recommended towing speed. Be sure the towing machine has sufficient braking capacity to stop the towed load. If the towed machine cannot be braked, a tow bar must be used or two towing machines must be used. - one in front pulling and one in the rear to act as a brake. Avoid towing over long distances.
 - Observe proper maintenance procedures.
 - Whenever servicing or replacing hardened pins, etc., use a brass drift or other suitable material between the hammer and pin. Alternate: Use a brass hammer, drift or suitable material on the pin, etc.
 - Keep the brakes and steering systems in good operating condition.
 - Replace all missing, illegible or damaged safety signs. Keep all safety signs clean.
- Before beginning any inspection or maintenance procedures, secure a "DO NOT OPERATE" tag to the operator's console to inform the operator that the machine will be inoperable for inspection and maintenance. This tag will prevent accidental starting of the machine.
 - Wear protective glasses and other required safety equipment when servicing or repairing the machine.
 - Wear gloves to protect hands when handling cable.
 - Disconnect the battery before working on the electrical system. Know the consequences of disconnecting any electronic or computer devices.

FUEL HANDLING PRECAUTIONS

- Do not smoke or permit open flames while fueling or near fueling operations.
- Never remove the fuel cap or refuel gasoline engine powered machines with the engine running or hot. Never allow fuel to spill on hot machine components. Never allow fuel to contaminate the environment.
- To avoid spilling fuel, maintain control of the fuel filler nozzle when filling the tank.
- Do not fill the fuel tank completely to the top. Allow room for expansion.
- Clean up spilled fuel immediately and dispose of contaminated material in an environmentally correct manner.
- Tighten the fuel tank cap securely. Should the fuel cap be lost, replace it only with the original manufacturers approved cap. Use of a non-approved cap without proper venting may result in pressurization of the tank.
- Never use fuel for cleaning purposes.
- Use the correct fuel grade for the operating season.

BURN PREVENTION

WARNING: BATTERY ACID CAUSES SEVERE BURNS. Batteries contain sulfuric acid. Avoid contact with skin, eyes or clothing.

Antidote: **EXTERNAL** - Flush with water.

 Antidote: **INTERNAL** - Drink large quantities of water or milk.

DO NOT induce vomiting. Seek medical attention immediately.

EYES - Flush with water for 15 minutes and seek medical attention immediately.

M144B

WARNING: BATTERIES PRODUCE EXPLOSIVE GASES. Keep sparks, flame, cigars and cigarettes away. Ventilate when charging or using in enclosed area. Always wear eye protection when working near batteries. Wash hands after handling. **KEEP OUT OF REACH OF CHILDREN.**



- When the battery electrolyte is frozen, the battery can explode if, you try to charge the battery, or you try to jump start and run the engine. To prevent the battery electrolyte from freezing, try to keep the battery at full charge. If you do not follow these instructions, you or others in the area can be injured

- Hot coolant can spray out if the radiator cap is removed. To remove the radiator cap, let the cooling system cool, turn to the first notch, wait until the pressure is released, then remove the radiator cap.

HAZARDOUS CHEMICAL PRECAUTIONS

- If you are exposed to or come in contact with hazardous chemicals you can be seriously injured. The fluids, lubricants, paints, adhesives, coolants, etc., used with your machine can be hazardous.
- Material Safety Data Sheets (MSDS) provide information about the chemical substances within a product, safe handling procedures, first aid measures and procedures to be taken when the product is accidentally spilled or released. MSDS are available from your dealer.
- Before you service your machine, check the MSDS for each fluid, lubricant, etc., used in this machine. This information indicates what the risks are and how to service the machine safely. Follow this information when servicing the machine.
- Before you service this machine and before you dispose of the old fluids and lubricants, always remember the environment. **DO NOT** put oil or fluids into the ground or into containers that can leak.
- Check with your local environmental or recycling center or your dealer for correct disposal information.

TRANSPORTING PRECAUTIONS

Know the rules, laws, and safety equipment necessary for transporting this machine on a road or highway.

ROLL-OVER PROTECTIVE STRUCTURE (IF EQUIPPED)

Do **NOT** modify the ROPS in any manner. Unauthorized modifications such as welding, drilling, cutting, or adding attachments can weaken the structure and reduce your protection. Replace ROPS if it is subjected to roll-over or damage. Do not attempt to repair.

FIRE EXTINGUISHER

It is recommended that you have a fire extinguisher on your machine. Contact your dealer for the type and location of a fire extinguisher on this machine.

FIRE PREVENTION

Remove all trash or debris from the machine each day. Check the engine area and exhaust system

SEAT BELT PRECAUTIONS

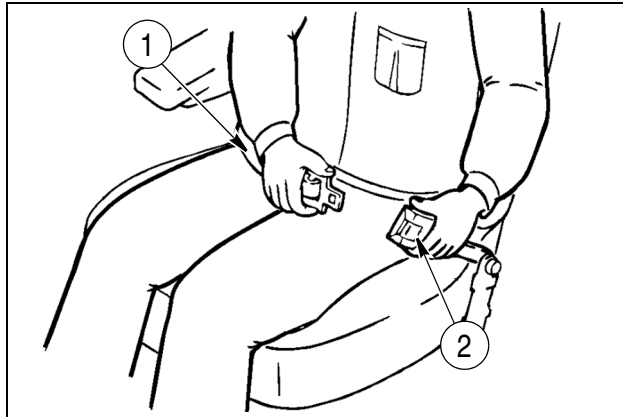

BC02N375

Figure 5

1. RIGHT HAND BELT STRAP
2. LATCH MECHANISM

1. Insert the metal end of the right-hand belt strap into the latch mechanism on the left-hand side of the seat.
2. To unlatch the seat belt, press the red button on the left-hand side latch mechanism.



WARNING: Before starting the engine make certain seat belts are securely fastened. The seat belt can help insure your safety if it is used and properly maintained. Never wear a seat belt loosely or with slack in the belt system. Never wear the belt in a twisted condition or pinched between the seat structural members.

M422A

EMERGENCY EXIT HAMMER

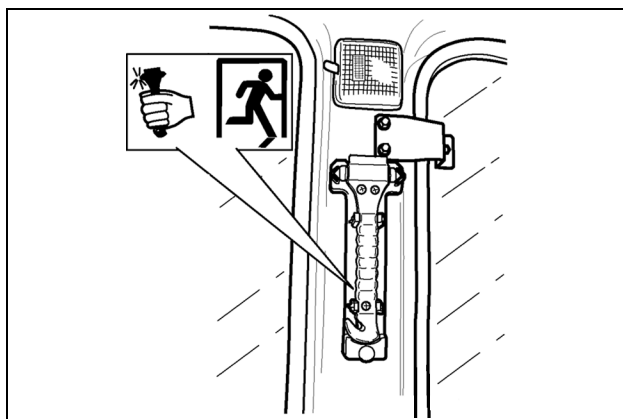

DC04D572

Figure 6

An emergency exit hammer is provided on the right side of cab. In case of emergency, take the emergency hammer, break the cab glass, and escape from the cab. In addition, the emergency hammer is equipped with a cutter on the lever side to cut seat belt, etc.

SPECIFIC PRECAUTIONS TO THIS MACHINE

- Keep the load or tool as low as possible while moving the machine around the job site.
- Never smoke while refueling.
- Do not use tractive force of the machine for loading the bucket attachment nor to push or pull any objects.
- Do not use swinging force of the machine for operations.
- Do not perform “hammering” operation with the bucket.
- Do not use this machine for anything other than its intended purpose.
- DO NOT OPERATE bucket and arm cylinders to stroke end repeatedly.
- Do not over exert the machine’s capacities.
- Never pull standing objects toward the machine.
- Do not use the long reach attachment for general construction work at any time.

DECALS



WARNING: *An illegible or missing decal can have far-reaching consequences. Inspect decals daily. Clean and replace damaged decals as necessary.*

CE-NA000



WARNING: *Make sure that the decals are perfectly legible, clean them regularly and replace decals that are destroyed, lost, painted over or no longer legible, with new ones. When parts bearing decals are replaced, be sure to put new decals on each new part.*

CE-NA000



NOTE: *When you clean the decals, use only a cloth, water and soap. Do not use solvents, gasoline, etc.*

NOTE: *This chapter only covers decals relating to safety and machine operation and servicing. For information on all decals for the machine, consult your authorized dealer.*

NOTE: *Safety Decals on this machine use the words **Danger, Warning, or Caution**, which are defined as follows:*

- **DANGER:** Indicates an immediate hazardous situation that, if not avoided, will result in death or serious injury. The color associated with Danger is RED.
- **WARNING:** Indicates a potentially hazardous situation that, if not avoided, could result in death or serious injury. The color associated with Warning is ORANGE.
- **CAUTION:** Indicates a potentially hazardous situation which, if not avoided, may result in minor or moderate injury. It may also be used to alert against unsafe practices. The color associated with Caution is YELLOW.

If Safety Decals on this machine are ISO two panel Pictorial, decals are defined as follows:

- The first panel indicates the nature of the hazard.
- The second panel indicates the appropriate avoidance of the hazard.
- Background color is YELLOW
- Prohibition symbols such as   and  if used are RED.

BOOM AND ARM MOVEMENT - CAUTION

Located on seat stand cover - Part Number YN20T01013P1

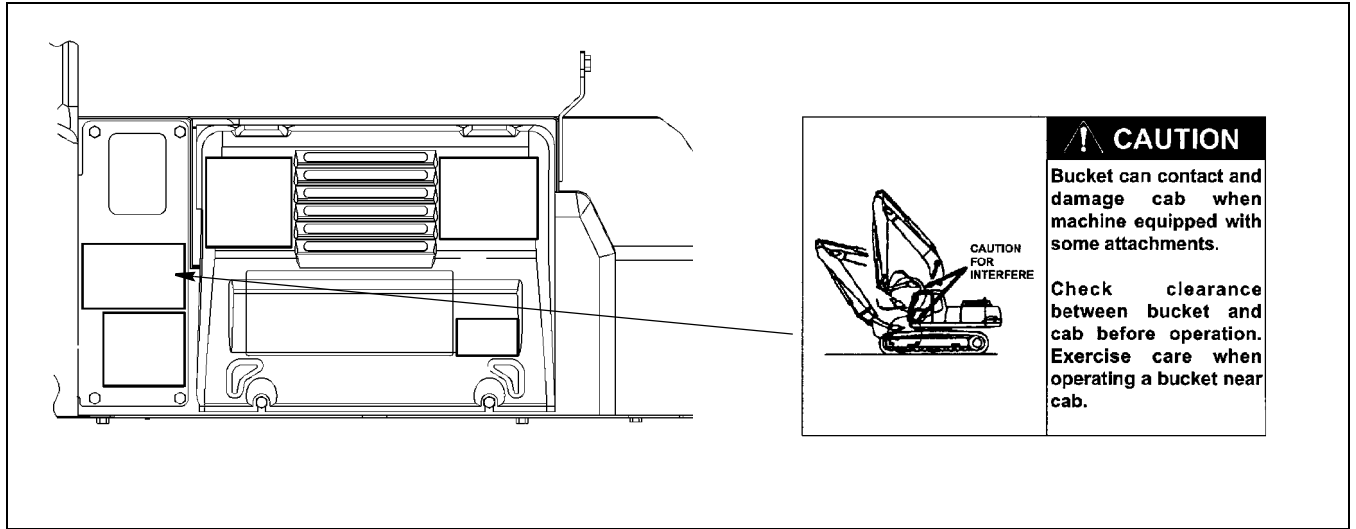

BS08A058/BS07M647

Figure 7

HYDRAULIC OIL - WARNING

Located on hydraulic tank- Part Number PW20T01007P1

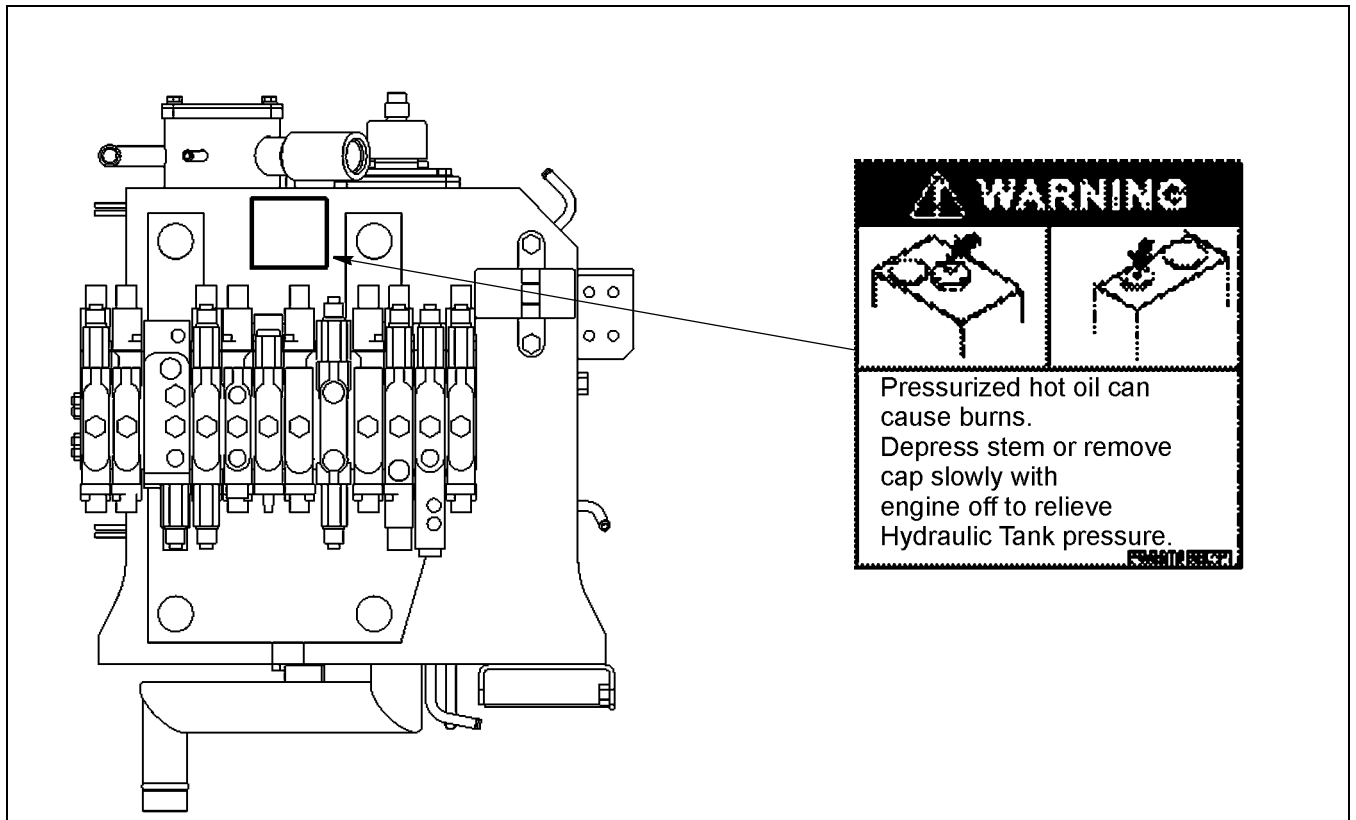

BS07M639/PW20T01007P1

Figure 8

SAFETY CONTROLS - WARNING

Located on seat stand cover - Part Number YN20T01016P1

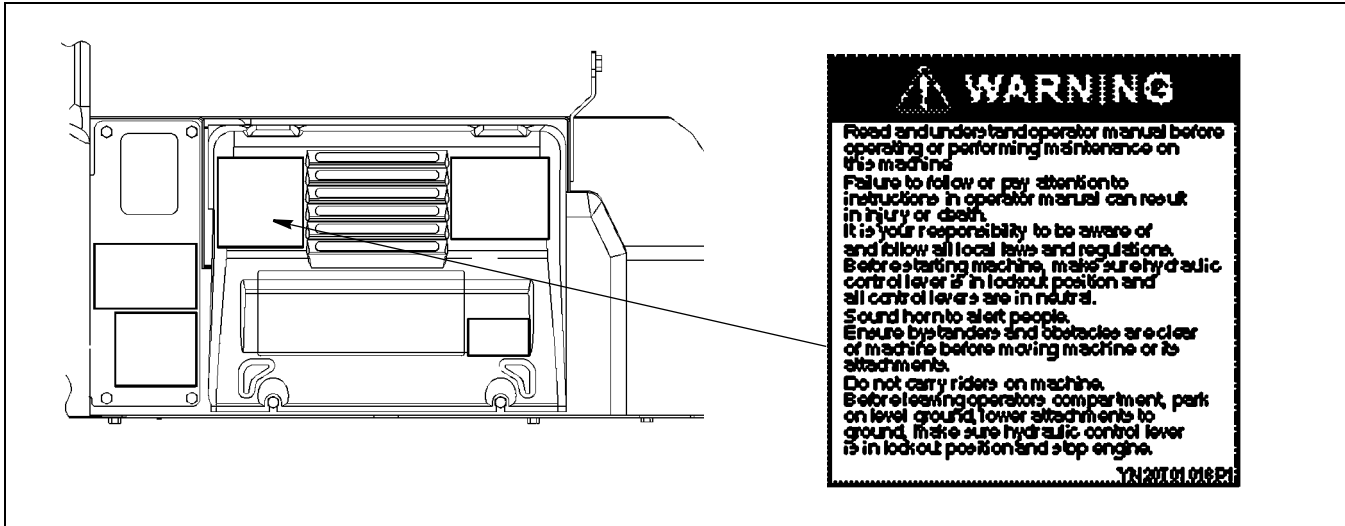

BS08A058/BS07M647

Figure 9

HOT SURFACES - CAUTION

Located on engine door hinge - Part Number YN20T01220P1

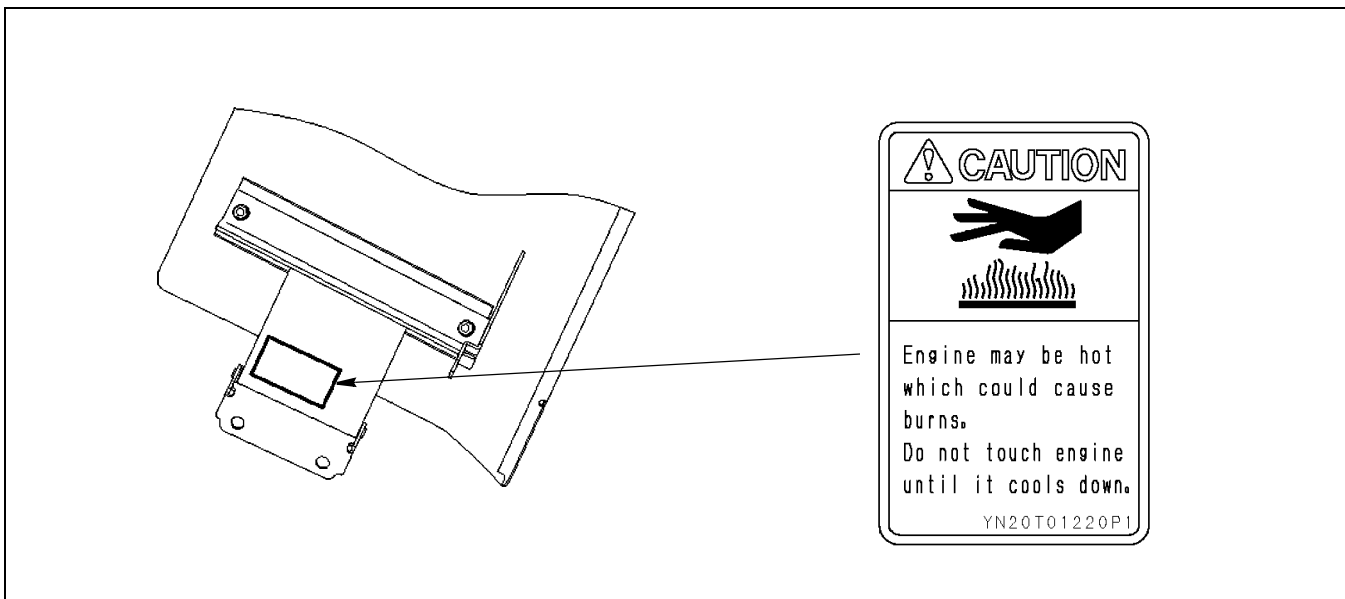

BS07M640/YN20T01220P1

Figure 10

This as a preview PDF file from best-manuals.com



Download full PDF manual at best-manuals.com