

BOMAG

FAYAT GROUP

Service Manual

BC 573 RB-3



S-930-0070

S/N 101 930 16 1001>

Refuse compactor

Table of contents

1	General	9
	1.1 Introduction	10
	1.2 Concerning your safety	12
	1.2.1 Basic prerequisites.....	12
	1.2.2 Definition of responsible persons.....	15
	1.2.3 Fundamentals for safe operation.....	16
	1.2.4 Handling fuels and lubricants.....	18
	1.2.5 Loading / transporting the machine.....	24
	1.2.6 Start up procedure.....	25
	1.2.7 Driving the machine; working operation.....	26
	1.2.8 Refuelling.....	28
	1.2.9 Emergency procedures.....	28
	1.2.10 Maintenance work.....	29
	1.2.11 Repair.....	31
	1.2.12 Signage.....	31
	1.3 Maintenance and repair	38
	1.3.1 Notes on repair.....	38
	1.3.2 Preliminary remarks and safety notes.....	54
	1.3.3 Preparations / concluding work.....	55
	1.3.4 Parking the machine in secured condition.....	60
2	Technical data	63
	2.1 Technical data	64
	2.1.1 Noise and vibration data.....	67
	2.2 Additional technical data	68
	2.3 Terms and basis of calculation	71
	2.4 Fuels and lubricants	72
	2.4.1 Engine oil.....	72
	2.4.2 Fuel.....	73
	2.4.3 Coolant.....	74
	2.4.4 Hydraulic oil.....	77
	2.4.5 Gear oil SAE 80W-140.....	77
	2.4.6 Lubrication grease.....	78
	2.5 List of fuels and lubricants	79
3	Overview of machine	81
	3.1 General information	82
	3.2 Electric systems	85
	3.3 Overview of hydraulics	87
	3.4 Machine assemblies	90
	3.4.1 Diesel engine.....	90
	3.4.2 Air conditioning.....	92
	3.4.3 Central lubrication system.....	93
	3.4.4 Overview of maintenance flaps and doors.....	96
4	Electric systems	97
	4.1 Basic principles	99

Table of contents

4.1.1	Measuring method.....	99
4.1.2	Understanding circuit diagrams.....	104
4.1.3	Telemecanique switch.....	115
4.1.4	Deutsch plug, series DT and DTM.....	117
4.1.5	Magnetic coil plug.....	121
4.1.6	Clip-on technology.....	123
4.2	Overview of electric system.....	127
4.2.1	Operator's stand.....	129
4.2.2	Wiring.....	131
4.2.3	CAN BUS overview.....	137
4.2.4	Table of fuels and lubricants.....	138
4.3	Starting the engine with jump leads.....	148
4.4	Installation locations of control units.....	149
4.5	Fuse assignment.....	154
4.5.1	Notes on safety.....	154
4.5.2	Central electrics.....	154
4.5.3	Main fuses.....	155
4.5.4	Control console cabin.....	156
4.6	Description of electrical components.....	157
4.6.1	Control console cabin.....	163
4.6.2	Control unit for air conditioning, A72.....	165
4.7	Training of electric system.....	168
4.8	Inspection and maintenance work.....	226
4.8.1	Maintenance Table.....	226
4.8.2	Every 500 operating hours.....	226
4.8.3	As required.....	227
5	Hydraulic system.....	229
5.1	Basic principles.....	231
5.1.1	Open and closed hydraulic circuit.....	231
5.1.2	Swash plate principle, pump.....	233
5.1.3	Swash plate principle, motor.....	234
5.1.4	External gear pumps.....	236
5.2	Overview of hydraulics.....	238
5.3	Description of hydraulic components.....	243
5.3.1	Travel pump, A4VG71 DA.....	243
5.3.2	Travel pump, A4VG71 DG.....	250
5.3.3	Fan pump, A4VG56 EF-EP.....	256
5.3.4	Steering and working pump, A10VO/VSO.....	261
5.3.5	Travel motor, A6VM HA2T.....	266
5.3.6	Fan motor.....	270
5.4	Description of hydraulic circuits.....	272
5.4.1	Charge circuit, engine hood, brake and travel speed range selection.....	273
5.4.2	Travel system.....	280
5.4.3	Cooling system.....	284
5.4.4	Working hydraulics.....	290
5.5	Tests and adjustments.....	294

5.5.1	Pressure tests in the travel circuit.....	296
5.5.2	Checking high pressure relief valves and pressure override.....	297
5.5.3	Charge pump high pressure test.....	299
5.5.4	Travel pump high pressure test (individual test).....	300
5.5.5	Checking the charge pressure.....	301
5.6	Inspection and maintenance work.....	303
5.6.1	Maintenance Table.....	303
5.6.2	Checks prior to start up.....	303
5.6.3	Every 500 operating hours.....	305
5.6.4	Every 1000 operating hours.....	306
5.6.5	Every 2000 operating hours.....	309
6	Machine assemblies.....	313
6.1	Diesel engine.....	314
6.1.1	Diesel engine - description.....	315
6.1.2	Engine electrics.....	335
6.1.3	Inspection and maintenance work.....	372
6.2	Oscillating articulated joint.....	396
6.2.1	Repair overview.....	397
6.2.2	Repairing the articulated joint.....	398
6.2.3	Inspection and maintenance work.....	404
6.3	Compactor wheels and dozer blade.....	405
6.3.1	Inspection and maintenance work.....	405
6.4	Central lubrication system.....	416
6.4.1	Overview of central lubrication system.....	416
6.4.2	Technical description.....	417
6.4.3	Control board.....	419
6.4.4	Lubrication process.....	426
6.4.5	Progressive distributor.....	427
6.4.6	Lubrication oil pump.....	430
6.4.7	Inspection and maintenance work.....	434
6.5	Air conditioning.....	437
6.5.1	Overview of air conditioning.....	438
6.5.2	Control unit for air conditioning, A72.....	440
6.5.3	Physical principles.....	443
6.5.4	Refrigerant R134a.....	445
6.5.5	Compressor oil / refrigeration oil.....	447
6.5.6	Working principle of the air conditioning system.....	449
6.5.7	Monitoring devices.....	450
6.5.8	Description of components.....	451
6.5.9	Compressor.....	457
6.5.10	Emptying in case of repair.....	459
6.5.11	Drying and evacuation.....	460
6.5.12	Filling instructions.....	460
6.5.13	Steam table for R134a.....	464
6.5.14	Inspection and maintenance work.....	468
6.6	Auxiliary heating, AIRTRONIC.....	479

Table of contents

6.6.1	Description of function.....	479
6.6.2	Fuse assignment.....	482
6.6.3	Control panel.....	482
6.6.4	Inspection and maintenance work.....	484
7	Troubleshooting.....	487
7.1	Preliminary remarks.....	489
7.2	Emergency procedures.....	490
7.2.1	Actuating the emergency stop switch.....	490
7.2.2	Emergency exit.....	490
7.2.3	Disconnect the battery.....	490
7.2.4	Towing the machine.....	490
7.2.5	After towing.....	493
7.3	Troubleshooting, electrical systems.....	495
7.3.1	Preliminary remarks.....	495
7.3.2	Starting the engine with jump leads.....	498
7.3.3	Checking the main battery switch.....	499
7.3.4	Fuse assignment.....	499
7.3.5	ESX, checking the electric power supply.....	502
7.3.6	Diagnostics concept.....	510
7.4	Trouble shooting, diesel engine.....	513
7.4.1	Engine faults.....	513
7.4.2	Starting the engine with jump leads.....	515
7.4.3	Operating the engine emergency mode.....	516
7.4.4	Deutz DTC fault code list, EMR3.....	517
7.5	Trouble shooting, hydraulics.....	584
7.5.1	Emergency operation of hood.....	584
7.5.2	Insufficient hydraulic power.....	587
7.5.3	Troubleshooting axial piston pumps.....	590
7.5.4	Troubleshooting axial piston motors.....	592
7.5.5	Troubleshooting table for hydraulic components.....	594
7.6	Troubleshooting, air conditioning system.....	602
7.6.1	Trouble shooting in refrigerant circuit, basic principles.....	602
7.6.2	Trouble shooting procedure.....	608
7.6.3	Leak test.....	617
7.6.4	Checking the magnetic clutch.....	618
7.7	Troubleshooting, central lubrication system.....	620
7.7.1	Function control.....	620
7.7.2	Faults and causes.....	622
7.7.3	Fault - Cause - Remedy.....	624
7.7.4	Failure of central lubrication system (grease emerges from relief valve).....	626
7.8	Troubleshooting, auxiliary heating.....	628
7.8.1	Fuse assignment.....	628
7.8.2	Components.....	629
7.8.3	Control and safety elements.....	630
7.8.4	Trouble shooting.....	630
7.8.5	Diagnostics of control panel, old version.....	631

7.8.6	Diagnostics of control panel, new version.....	639
7.8.7	Check the fuel supply.....	642
7.8.8	Circuit diagram, AIRTRONIC D2/D4.....	644
8	Special tools.....	649
8.1	Special tools, electrics.....	650
8.2	List of special tools.....	651
9	Measures prior to extended shutdown period.....	653
9.1	Measures before shutting down.....	654
9.2	Battery service during prolonged machine downtimes.....	655
9.3	Measures before restarting.....	656
10	Index.....	657
	Appendix.....	669
A	Circuit diagrams.....	673
A.1	Circuit diagram 382.....	673
A.2	Hydraulic diagram 571 908 26.....	748

1

General

1.1 Introduction	10
1.2 Concerning your safety	12
1.2.1 Basic prerequisites.....	12
1.2.2 Definition of responsible persons.....	15
1.2.3 Fundamentals for safe operation.....	16
1.2.4 Handling fuels and lubricants.....	18
1.2.5 Loading / transporting the machine.....	24
1.2.6 Start up procedure.....	25
1.2.7 Driving the machine; working operation.....	26
1.2.8 Refuelling.....	28
1.2.9 Emergency procedures.....	28
1.2.10 Maintenance work.....	29
1.2.11 Repair.....	31
1.2.12 Signage.....	31
1.3 Maintenance and repair	38
1.3.1 Notes on repair.....	38
1.3.2 Preliminary remarks and safety notes.....	54
1.3.3 Preparations / concluding work.....	55
1.3.4 Parking the machine in secured condition.....	60

1.1 Introduction

General

This manual:

- addresses the BOMAG Customer Service and professionally trained personnel.
- provides support for repair work or maintenance procedures on the machine.

This manual described the deinstallation, dismantling , assembly, installation as well as the repair of components and assembly groups as far as this makes sense with respect to tools and spare parts supply.

Index

The index is a reference register that will help you to find information in this Service Manual. The index lists keywords in alphabetical order. Cross references (keywords related to page numbers) enable quick and convenient search/navigation.

Keywords concerning the following subjects are listed in the index:

- Electrical operating means
- Plug designations
- Overviews
- Fault codes
- Troubleshooting
- ...

Documentation

For the BOMAG machines described in this manual the following documentation is additionally available:

- Operating and maintenance instructions
- Spare parts catalogue
- Service information (if necessary)

Maintenance/parts service

- Specialist teams are available for you in Germany, Europe and overseas. This tight network ensures close customer contact all over the world.
- Parts for maintenance, service and repair are available from our branch offices and dealers at very short notice.
- BOMAG guarantees long-term availability of all common parts.
- Well-designed catalogues provide an easy guide to finding and ordering the required parts.
- Only use genuine BOMAG parts. These have been specially adapted to the corresponding machine. In this way, you will prevent any problems arising and unnecessary downtimes of your machine.

Updating service

This manual is not subject of an updating service. For this reason we would like to draw your attention to the additionally published service informations.

In case of a new release all necessary changes will be included.

In the course of technical development we reserve the right for technical modifications without prior notification.

Copyright

Information and illustrations in this manual must not be reproduced and distributed, nor must they be used for the purpose of competition without the consent of BOMAG. All rights according to the copyright law remain expressly reserved.

1.2 Concerning your safety

1.2.1 Basic prerequisites

1.2.1.1 General

This machine has been built in compliance with the latest technical standard and complies with the applicable regulations and technical rules.

However, dangers for persons and property may arise from this machine, if:

- it is used for purposes other than the ones it is intended for,
- it is operated by untrained personnel,
- it is changed or converted in an unprofessional way,
- the safety instructions are not observed.

Each person involved in the operation, maintenance and repair of the machine must therefore read and comply with these safety regulations. If necessary, the operating company must obtain the relevant signatures as confirmation.

Furthermore, the following obviously also applies:

- applicable accident prevention instructions,
- generally accepted safety and road traffic regulations,
- country/state specific safety regulations.

It is the duty of the operator to be acquainted with the safety regulations and to apply these accordingly. This also applies for local regulations and regulations concerning different types of handling activities. Should the recommendations in these instructions be different from the regulations valid in your country, you must comply with the safety regulations valid in your country.

1.2.1.2 Explanation of signal words used:



DANGER!

Danger to life if failing to comply!

Sections marked accordingly indicate an extremely dangerous situation that could lead to fatal or severe injuries, if this warning is disregarded.



WARNING!

Danger to life or danger of severe injuries if failing to comply!

Sections marked accordingly indicate a dangerous situation that could lead to fatal or severe injuries, if this warning is disregarded.

General – Concerning your safety



CAUTION!

Danger of injury if failing to comply!

Sections marked accordingly indicate a dangerous situation that could lead to fatal or severe injuries, if this warning is disregarded.



NOTICE!

Danger of material damage if failing to comply!

Sections marked accordingly indicate possible dangers for machines or components.



Sections marked accordingly indicate technical information or notes on using the machine or its components.





ENVIRONMENT!

Environmental damage if failing to comply!





Paragraphs marked accordingly indicate practices for safe and environment-friendly disposal of fuels and lubricants as well as replacement parts.

1.2.1.3 Personal protective equipment

Depending on the work to be carried out, personal protective equipment is required (to be provided by the operating company):

	Working clothes	Tight fitting working clothes with low tear resistance, tight sleeves and without any projecting parts protect against being caught by moving components.
	Safety shoes	To protect against heavy falling parts and slipping on slippery ground.
	Protective gloves	To protect the hands against excoriation, punctures or deep injuries, against irritating and caustic substances as well as against burns.

General – Concerning your safety

	Safety goggles	To protect the eyes against airborne particles and squirting fluids.
	Face protection	To protect the face against airborne particles and squirting fluids.
	Hard hat	To protect the head against falling parts and to protect against injuries.
	Hearing protection	To protect hearing against excessive noise.
	Respiratory protection	To protect respiratory tracts against substances or particles.

1.2.1.4 Intended use

This machine must only be used for:

- Compaction and distribution of refuse on sanitary landfill sites.

Intended use also includes compliance with the specified operating, maintenance and repair measures.

1.2.1.5 Intended use

This machine must only be used for:

- Soil and refuse compaction as well as distribution and levelling work.

Intended use also includes compliance with the specified operating, maintenance and repair measures.

1.2.1.6 Improper use

Dangers may arise from the machine when it is used for purposes other than the one it is intended for.

Any danger caused by improper use is the sole responsibility of the operating company or driver/operator, the manufacturer cannot be made liable.

Examples for improper use are:

- Driving on ground with insufficient load bearing capacity (soft spots, edges, embankments)
- Driving on subbases or under conditions, which could be destroyed by the wheels
- Fire fighting operations
- Lifting gear operation; attachment of lifting tackle to dozer blade/bucket
- Lifting gear operation; attachment of lifting tackle to dozer blade/tilt blade

transporting persons, except the machine driver, is prohibited.

starting and operation of the machine in explosive environments and in underground mining is prohibited.

1.2.2 Definition of responsible persons

1.2.2.1 Operating company

The operating company is the natural or juridical person who uses the machine or in who's name the machine is used.

The operating company must make sure that the machine is only used for the purpose it is intended for and in strict compliance with the safety regulations mentioned in these operating and maintenance instructions.

The operating company must determine and assess the danger in its company. It must then take appropriate action to ensure health and safety at work for its employees and point out any remaining dangers.

The operating company must determine whether there are special operational hazards such as a toxic atmosphere or limiting soil conditions. Such conditions require special, additional measures to remove or reduce the hazard.

The operating company must make sure that all users read and understand the information concerning safety.

The operating company is responsible for the planning and professional execution of regular safety inspections.

1.2.2.2 Expert / qualified person

An expert / qualified person is a person who, based on his/her professional education and experience, has profound knowledge in the field of construction equipment and the machine in question in particular.

This person is acquainted with the applicable governmental industrial safety regulations, accident prevention instructions, guidelines and generally acknowledged technical rules and regulations (standards, directives, technical rules of other member states of the European Union or other contractual states concerning the agreement about the European Economic Area) in as far as is necessary to be able to judge the safe condition of this machine.

1.2.2.3 Driver / operator

This machine must only be operated by trained, instructed persons entrusted by the operating company aged 18 or more.

Observe your local laws and regulations.

Rights, obligations and rules of conduct for driver or operator:

The driver or operator must:

- be instructed about his rights and obligations,
- wear protective equipment as appropriate for the application,
- have read and understood the operating instructions,
- have made himself familiar with the operation of the machine,
- be physically and psychologically able to drive and operate the machine.

Persons under the influence of alcohol, medication or drugs are not allowed to operate, service or repair the machine.

Maintenance and repair work requires specific knowledge and must therefore only be performed by trained specialists.

1.2.3 Fundamentals for safe operation

1.2.3.1 Remaining dangers, remaining risks

Despite careful work and compliance with standards and regulations it cannot be ruled out that further dangers may arise when working with and handling the machine.

Both the machine as well as all other system components comply with the currently valid safety regulations. Nevertheless, remaining risks cannot be ruled out completely, even when using the machine for the purpose it is intended for and following all information given in the operating instructions.

A remaining risk can also not be excluded beyond the actual danger zone of the machine. Persons remaining in this area must pay particular attention to the machine, so that they can react immediately in case of a possible malfunction, an incident or failure etc.

All persons remaining in the area of the machine must be informed about the dangers that arise from the operation of the machine.

1.2.3.2 Regular safety inspections

Have the machine inspected by an expert / qualified person as required for the conditions the machine is working under, but at least once every year.

1.2.3.3 Modifications and alterations to the machine

Unauthorized changes to the machine are prohibited for safety reasons.

Original parts and accessories have been specially designed for this machine.

We wish to make explicitly clear that we have not tested or approved any parts or accessories not supplied by us.

The installation and/or use of such products may have an adverse effect on the active and/or passive safety.

1.2.3.4 Damage, defects, misuse of safety devices

Machines which are not safe to operate or in traffic must be immediately taken out of service and shall not be used, until these deficiencies have been properly rectified.

Safety installations and switches must neither be removed nor must they be made ineffective.

1.2.3.5 Roll Over Protective Structure (ROPS)

The frame of the machine must not be warped, bent or cracked in the area of the ROPS fastening.

The ROPS must not show any rust, damage, hairline cracks or open fractures.

The real machine weight must never exceed the testing weight for the ROPS.

No accessories may be welded or bolted on and no additional holes must be drilled without the consent of the manufacturer, since this will impair the strength of the unit.

The ROPS must therefore also not be straightened or repaired if it is damaged.

A defect ROPS must generally be replaced with an original spare part in close coordination with the manufacturer.

1.2.4 Handling fuels and lubricants

1.2.4.1 Preliminary remarks

The operating company must ensure that all professional users have read and follow the corresponding safety data sheets for the individual fuels and lubricants.

Safety data sheets provide valuable information about the following characteristics:

- name of substance
- possible dangers
- composition / information on constituents
- first-aid measures
- fire fighting measures
- measures in case of accidental release
- handling and storage
- limitation and monitoring of exposure / personal protective equipment
- physical and chemical properties
- stability and reactivity
- toxicological data
- environmental data
- notes on waste disposal
- information on transport
- legislation
- other data

1.2.4.2 Safety regulations and environmental protection regulations for handling diesel fuel

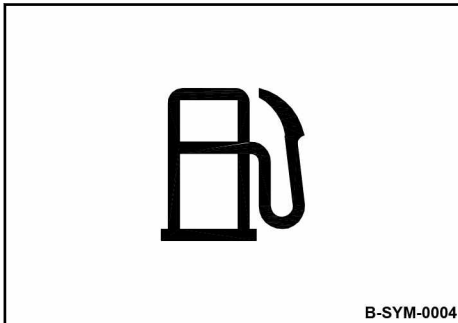

Fig. 1



WARNING!

Danger of burning by ignited diesel fuel!

- Do not allow diesel fuel to come into contact with hot components.
- Smoking and open fire is prohibited!
- Wear your personal protective equipment (protective gloves, protective clothing).



CAUTION!

Health hazard caused by contact with diesel fuel!

- Wear your personal protective equipment (protective gloves, protective clothing).
- Do not inhale any fuel fumes.
- Avoid contact.



CAUTION!

Danger of slipping on spilled diesel fuel!

- Immediately bind spilled diesel fuel with an oil-binding agent.



ENVIRONMENT!

Diesel fuel is an environmentally hazardous substance!

- Always keep diesel fuel in proper containers.
- Immediately bind spilled diesel fuel with an oil-binding agent and dispose of properly.
- Dispose of diesel fuel and fuel filters according to regulations.

General – Concerning your safety

1.2.4.3 Safety regulations and environmental protection regulations for handling oil

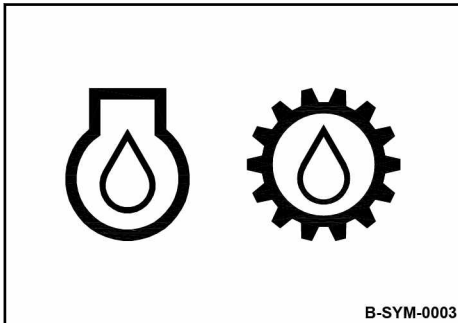

Fig. 2



WARNING!

Danger of burning by ignited oil!

- Do not allow oil to come into contact with hot components.
- Smoking and open fire is prohibited!
- Wear your personal protective equipment (protective gloves, protective clothing).



CAUTION!

Health hazard caused by contact with oil!

- Wear your personal protective equipment (protective gloves, protective clothing).
- Do not inhale any oil vapours.
- Avoid contact.



CAUTION!

Danger of slipping on spilled oil!

- Immediately bind spilled oil with an oil-binding agent.



ENVIRONMENT!

Oil is an environmentally hazardous substance!

- Always keep oil in proper containers.
- Immediately bind spilled oil with an oil-binding agent.
- Dispose of oil and oil filter according to regulations.

1.2.4.4 Safety regulations and environmental protection regulations for handling hydraulic oil

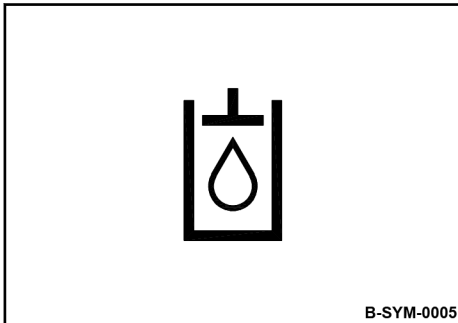

Fig. 3



WARNING!

Danger of injury caused by escaping pressure fluid!

- Always depressurize the hydraulic system before starting work in the hydraulic system.
- Wear your personal protective equipment (protective gloves, protective clothing, goggles).



Should pressure fluid penetrate the skin, immediate medical help is required.



WARNING!

Danger of burning by ignited hydraulic oil!

- Do not allow hydraulic oil to come into contact with hot components.
- Smoking and open fire is prohibited!
- Wear your personal protective equipment (protective gloves, protective clothing).



CAUTION!

Health hazard caused by contact with hydraulic oil!

- Wear your personal protective equipment (protective gloves, protective clothing).
- Do not inhale any oil vapours.
- Avoid contact.



CAUTION!

Danger of slipping on spilled oil!

- Immediately bind spilled oil with an oil-binding agent.



ENVIRONMENT!

Oil is an environmentally hazardous substance!

- Always keep oil in proper containers.
- Immediately bind spilled oil with an oil-binding agent.
- Dispose of oil and oil filter according to regulations.

General – Concerning your safety

1.2.4.5 Safety regulations and environmental protection regulations for handling coolants

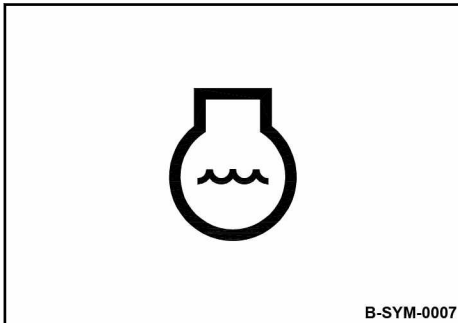

Fig. 4



WARNING!

Danger of scalding by hot fluid!

- Open the compensation tank only when the engine is cold.
- Wear your personal protective equipment (protective gloves, protective clothing, goggles).



CAUTION!

Health hazard caused by contact with coolant and coolant additives!

- Wear your personal protective equipment (protective gloves, protective clothing).
- Do not inhale any fumes.
- Avoid contact.



CAUTION!

Danger of slipping on spilled coolant!

- Immediately bind spilled coolant with an oil-binding agent.



ENVIRONMENT!

Coolant is an environmentally hazardous substance!

- Always keep coolant and coolant additives in proper containers.
- Immediately bind spilled coolant with an oil-binding agent and dispose of it according to regulations.
- Dispose of coolant according to regulations.

1.2.4.6 Safety regulations and environmental protection regulations for handling battery acid

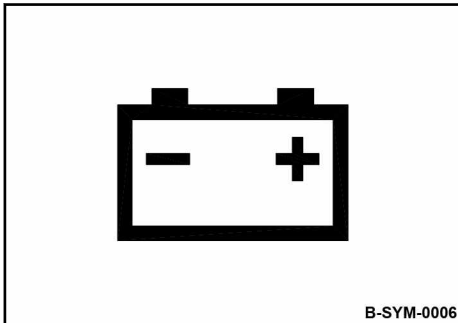

Fig. 5:



WARNING!

Danger of cauterization with acid!

- Wear your personal protective equipment (protective gloves, protective clothing, goggles).
- Do not allow clothes, skin or eyes to come into contact with acid.
- Rinse off spilled battery acid immediately with lots of water.



Rinse acid off clothes, skin or eyes immediately with lots of clean water.

Immediately call for medical advice in case of cauterization.



WARNING!

Danger of injury caused by exploding gas mixture!

- Remove the plugs before starting to recharge the battery.
- Ensure adequate ventilation.
- Smoking and open fire is prohibited!
- Do not lay any tools or other metal objects on the battery.
- Do not wear jewellery (watch, bracelets, etc.) when working on the battery.
- Wear your personal protective equipment (protective gloves, protective clothing, goggles).



ENVIRONMENT!

Battery acid is an environmentally hazardous substance!

- Dispose of battery and battery acid according to regulations.

General – Concerning your safety

1.2.4.7 Safety regulations and environmental protection regulations when handling lubrication grease

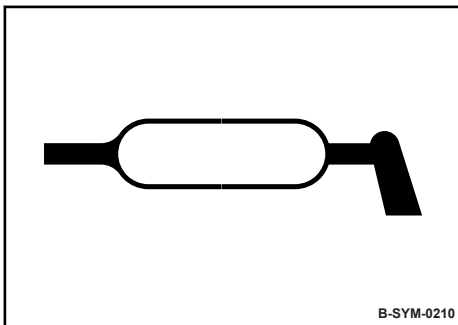

Fig. 6



CAUTION!

Health hazard caused by contact with lubrication grease!

- Wear your personal protective equipment (protective gloves, safety goggles, protective clothing).
- Avoid contact.



CAUTION!

Danger of slipping on lubrication grease!

- Collect and remove excess lubrication grease immediately.



ENVIRONMENT!

Lubrication grease is an environmentally hazardous substance!

- Always keep lubrication grease in proper containers.
- Collect excess lubrication grease and dispose of it according to regulations.
- Dispose of cloths soiled with lubrication grease according to regulations.

1.2.5 Loading / transporting the machine

Use only stable loading ramps of sufficient load bearing capacity.

Loading ramps and transport vehicle must be free of grease, oil, snow and ice.

The ramp inclination must be less than the gradability of the machine.

Make sure that persons are not endangered by the machine tipping or sliding off. The instructing person must stand within the view of the operator, but outside the danger area.

Do not use damaged or in any other way impaired lifting points.

Always use appropriate lifting and lashing means on the lifting and lashing points.

Use lifting and lashing gear only in the prescribed direction of load application.

Lifting and lashing gear must not be damaged by machine components.

Secure the machine on the transport vehicle against rolling, slipping and turning over.

Loads must only be attached and hoisted by an expert / capable person.

Lifting the machine is not permitted.

For transport by ship use a flat container with collapsible front and rear walls, so that the machine can be driven onto the container.

1.2.6 Start up procedure

1.2.6.1 Prior to starting up

Use only machines which are serviced at regular intervals.

Become acquainted with the equipment, the indicators and control elements, the working principle of the machine and the working area.

Use your personal protective equipment (hard hat, safety boots, if necessary also goggles and ear protection).

Do not take any loose objects with you or fasten them to the machine.

Before mounting the machine check whether:

- persons or obstructions are beside or under the machine,
- the machine is free of oily and combustible materials,
- all access steps, grips and platforms are free of obstacles, grease, oils, fuel, dirt, snow and ice,
- all safety elements are in place,
- all maintenance flaps and doors are closed and locked.

Use only the intended access steps and grips to mount the machine.

Before start up, carry out all required visual inspections and function tests.

If the following tests reveal damages or other faults, the machine must not be operated, until these deficiencies have been corrected.

Do not operate the machine with defective indicators and control elements.

1.2.6.2 Starting the engine

The machine must only be started and operated from the driver's seat.

Before starting and moving the machine, make sure that there is nobody in the danger zone.

To start, set all control levers to "neutral position".

Do not use any starting aids like start pilot or ether.

The machine must not be operated with damaged, missing or non-functional safety installations.

After starting check all display instruments.

General – Concerning your safety

Do not inhale exhaust fumes, because they contain toxic substances, which could cause damage to health, unconsciousness or even death.

For operation in closed or partly closed rooms ensure adequate ventilation.

1.2.6.3 Starting the engine with jump leads

Connect positive with positive and negative with negative (ground cable) – always connect the ground strap last and disconnect it first! A wrong connection will cause severe damage in the electric system.

Do not start the engine by shorting the electric terminals on the starter motor, because the machine may start to drive immediately.

1.2.6.4 Auxiliary heating

Exhaust gases are highly dangerous! Do not operate the auxiliary heating inside closed rooms.

1.2.7 Driving the machine; working operation

1.2.7.1 Persons in the danger area

Before taking up work, also after breaks, you should always convince yourself that the danger zone is free of persons or obstructions, especially when driving in reverse.

Give warning signals, if necessary. Stop work immediately if persons remain in the danger zone, despite the warning.

Do not step or stand in the articulation area of the machine when the engine is running.

1.2.7.2 Driving the machine

Always wear the seat belt when driving.

Do not drive on bases with insufficient load bearing capacity.

If the machine has contacted high-voltage power lines:

- do not leave the operator's stand,
- warn others from coming close to or touching the machine,
- if possible drive the machine out of the danger zone,
- have the power switched off.

Operate the machine only from the operator's platform.

Keep the cabin doors closed.

Do not adjust the driver's seat while driving.

Do not climb onto or off the machine while the machine is driving.

Change the travel direction only at standstill.

Do not use the machine to transport persons.

Do not use the dozer blade/bucket to transport persons – danger to life!

Do not use the dozer blade/tilt blade to transport persons – danger to life!

In case of unusual noises and development of smoke perform trouble shooting and have the fault corrected.

Match the speed to the working conditions.

Switch the lights on if the visibility is poor.

Always keep a safe distance to excavation pit borders, embankments and edges.

Refrain from any work that could adversely affect the stability of the machine.

Always keep a sufficient distance when passing through subways, under bridges, tunnels, electric power lines etc.

1.2.7.3 Driving up and down slopes

Do not drive on gradients or slopes exceeding the maximum gradeability of the machine ↪ *Chapter 2 „Technical data“ on page 63.*

Drive extremely carefully on gradients and always directly up or down the slope.

Soil conditions and weather influences impair the gradeability of the machine.

Wet and loose soil considerably reduces traction of the machine on inclinations and slopes. Increased danger of accident!

1.2.7.4 Parking the machine

Park the machine on horizontal, level, firm ground.

Before leaving the machine:

- Lower the dozer blade / bucket to the ground,
- Lower the dozer blade / tilt blade to the ground,
- shift all control levers to "Neutral position", "Off" or "0",
- apply the parking brake,
- shut down the engine, pull off the ignition key,
- pull off the main battery switch,
- secure the machine against unauthorized use.

Do not jump off the machine, but use hand grips and access steps.

Mark machines, which could be in the way, with a clearly visible sign.

When parking on ascents or descents use appropriate means to secure the machine against rolling.

1.2.8 Refuelling

Do not inhale any fuel fumes.

Refuel only with the engine stopped and the auxiliary heater switched off.

Do not refuel in closed rooms.

No open fire, do not smoke.

Static charges may be generated in the fuel as it passes through the filling system. The discharge of these charges in the presence of combustible vapours can cause fire or an explosion.

Ultra-low sulphur diesel fuel poses a higher risk of combustion caused by the static charging than diesel fuel with a higher sulphur content.

You should therefore always make sure that the filling system is properly grounded and that there is equipotential bonding to the machine. If necessary use a connecting cable between filling system and vehicle ground.

Apply measures against electrostatic charging.

Monitor the entire refuelling process.

Do not spill any fuel. Catch running out fuel, do not let it seep into the ground.

Wipe off spilled fuel. Keep dirt and water away from the fuel.

A leaking fuel tank can cause an explosion. Ensure tight fit of the fuel tank cover, if necessary replace immediately.

1.2.9 Emergency procedures

1.2.9.1 Actuating the emergency stop switch

In events of emergency and in case of danger actuate the emergency stop switch immediately.

The machine is braked immediately, the engine is shut down.

Restart the machine only after the danger that caused the actuation of the emergency stop switch has been eliminated.

In case of frequent use the wear on the multi-discs brakes will be very high, you should therefore never use the emergency stop switch as a service brake.

1.2.9.2 Disconnecting the battery

In events of emergency, e.g. in case of a cable fire, disconnect the battery from the vehicle network.

Pull out the main battery switch or lift off the battery pole to do so.

1.2.9.3 Towing the machine

Tow the machine only in case of emergency or to avoid an accident.

Before releasing the parking brake apply suitable measures to secure the machine against unintended rolling.

Use a tractor vehicle with sufficient traction and braking power for the unbraked towed load.

You should generally use a tow bar.

Before starting towing operations make sure that the fastening means are able to withstand the load and are fastened at the points provided for this purpose.

Before removing the towing facility apply appropriate measures to secure the machine against unintended rolling.

1.2.10 Maintenance work

1.2.10.1 Preliminary remarks

Adhere to the specified operating, maintenance and repair measures.

The machine must only be serviced by qualified personnel authorised by the operating company.

Keep unauthorised persons away from the machine.

When performing maintenance work on machines used in contaminated environments, all applicable national or local safety regulations must be applied.

Perform maintenance work only with the engine shut down.

Make sure that the engine cannot be accidentally started during maintenance work.

1.2.10.2 Work on hydraulic lines

Always lower the dozer blade / bucket to the ground and shut down the engine before relieving the hydraulic system.

Always lower the dozer blade / tilt blade to the ground and shut down the engine before relieving the hydraulic system.

Relieve hydraulic pressures before working on hydraulic lines. Hydraulic oil escaping under pressure can penetrate the skin and cause severe injury. Immediately call for medical advice when injured by hydraulic oil.

Do not step in front of or behind the wheels when performing adjustment work in the hydraulic system.

Do not change the setting of pressure relief valves.

Drain the hydraulic oil at operating temperature – danger of scalding!

General – Concerning your safety

Any hydraulic oil must be caught and disposed of in an environmentally friendly manner.

Always catch and dispose of hydraulic oils separately.

Do not start the engine after draining the hydraulic oil. Once all work is completed (with the system still depressurized!) check all connections and fittings for leaks.

Hydraulic hoses must be visually inspected at regular intervals.

Do not mix up hoses by mistake.

Only genuine BOMAG replacement hydraulic hoses ensure that the correct hose type (pressure range) is used at the right location.

1.2.10.3 Working on the engine

Do not work on the fuel system while the engine is running - danger to life due to high pressures!

Wait until the engine has stopped, then wait approx. another 15 minutes.

Keep out of the danger zone during the initial test run.

In case of leaks return to the workshop immediately.

Drain the engine oil at operating temperature – danger of scalding!

Wipe off spilled oil, collect leaking oil and dispose of it in an environmentally friendly way.

Store used filters and other oil contaminated materials in a separate, specially marked container and dispose of them in an environmentally friendly way.

The settings for idle speed and highest speed must not be changed, since this would affect the exhaust gas values and cause damage to engine and power train.

Engine and exhaust system work at high temperatures. Keep combustible materials away and do not touch any hot surfaces.

Check and change coolant only when the engine is cold. Collect coolant and dispose of it in an environmentally friendly way.

1.2.10.4 Maintenance work on electric components and battery

Before starting to work on electric parts of the machine disconnect the battery and cover it with insulating material.

Do not use fuses with higher ampere ratings and do not bridge fuses.

When working on the battery, smoking or open fire is prohibited!

Do not lay any tools or other metal objects on the battery.

Do not wear jewellery (watch, bracelets, etc.) when working on the battery.

The connection cables of the battery must not touch or rub against machine parts.

1.2.10.5 Working on the air conditioning

Faults on the air conditioning should only be remedied by authorized service personnel.

Do not perform welding work in the vicinity of the air conditioning. Danger of explosion!

Do not release refrigerant into the atmosphere, but dispose of it in line with environmental regulations.

1.2.10.6 Cleaning work

Do not perform cleaning work while the motor is running.

Allow the engine to cool down before starting cleaning work on engine and exhaust system.

Never use gasoline or other easily inflammable substances for cleaning.

When cleaning with a high pressure cleaner, do not subject electrical parts and insulation material to the direct jet of water, or cover them beforehand.

Do not guide the water jet into the exhaust pipe and into the air filter.

1.2.10.7 After maintenance work

Reassemble all guards and protective devices.

Close all maintenance flaps and maintenance doors again.

1.2.11 Repair

Identify a defective machine with a warning sign.

Only operate the machine after it has been repaired.

Repairs must only be performed by an expert/qualified person.

When replacing safety relevant components, only original spare parts must be used.

1.2.12 Signage

Keep stickers and signage in good and legible condition and comply with their meaning.

Replace damaged and illegible stickers or signage immediately.

General – Concerning your safety

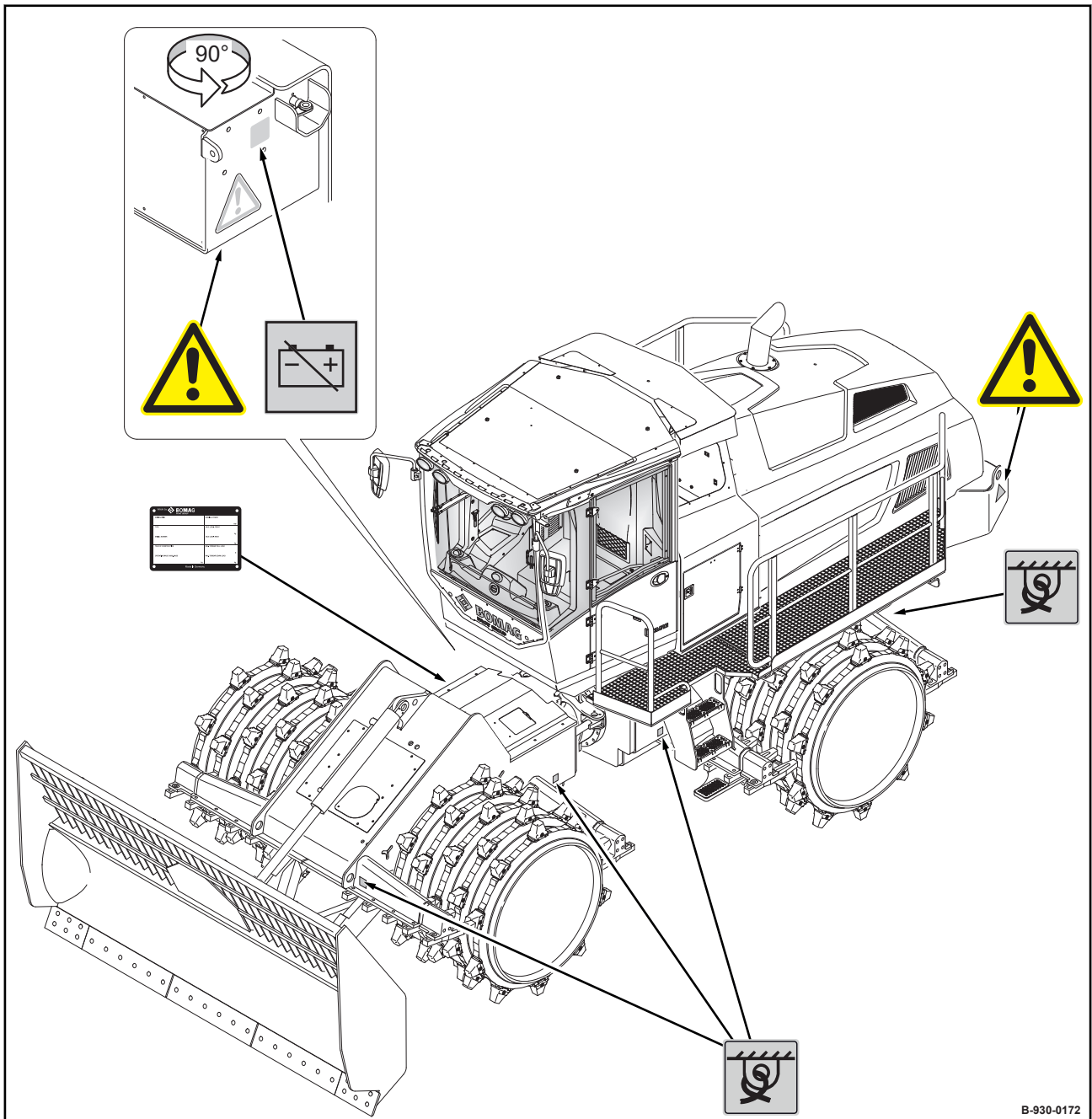
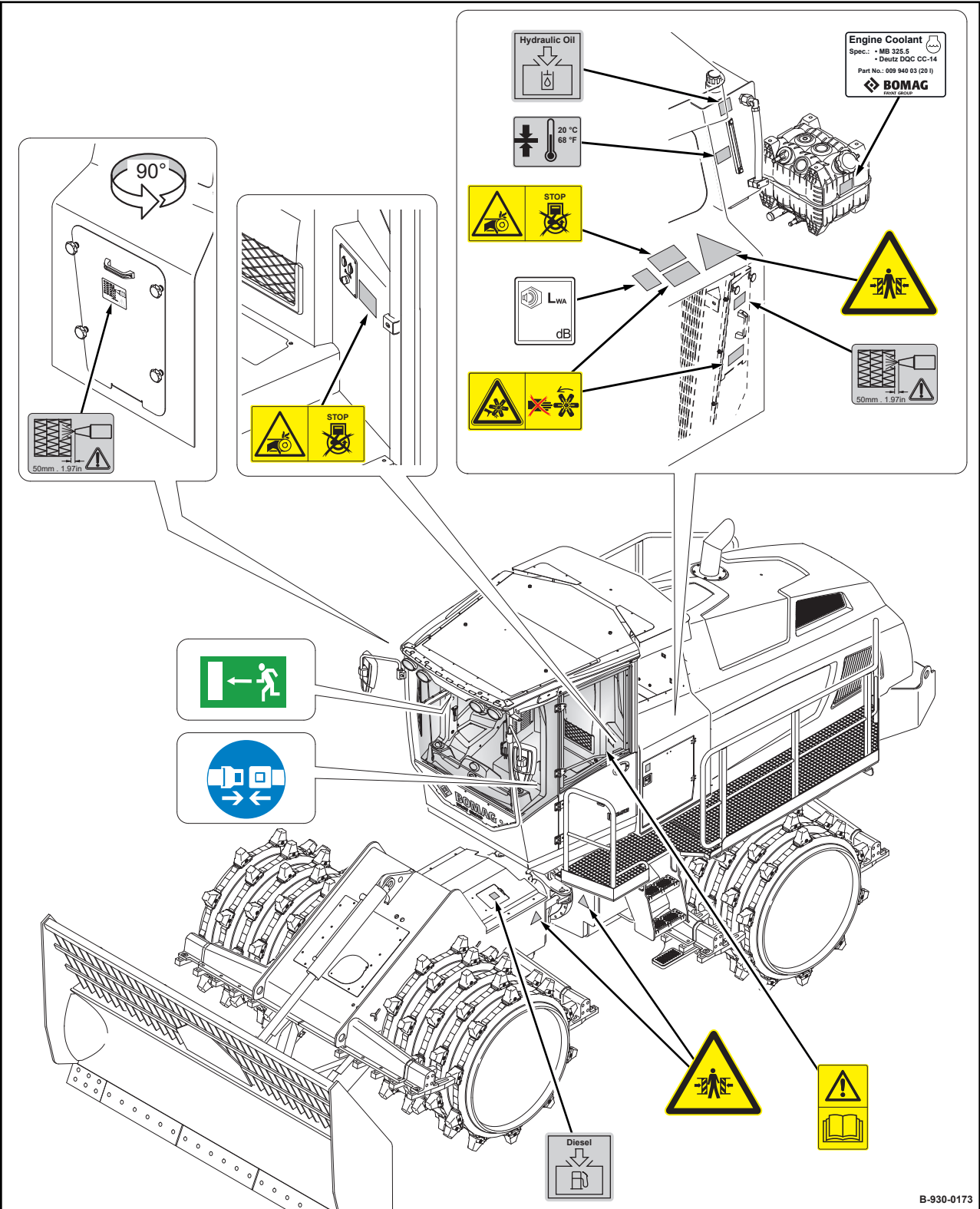

Fig. 7



B-930-0173

Fig. 8

General – Concerning your safety



Warning sticker - Danger zone

Fig. 9

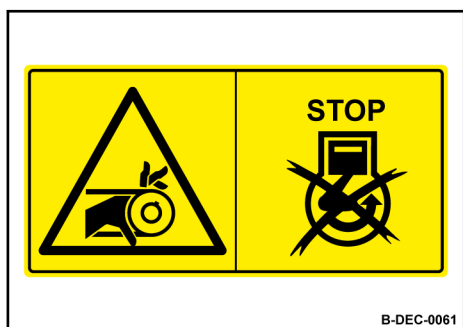

Warning sticker - Danger of being pulled in: Shut down the engine

Fig. 10

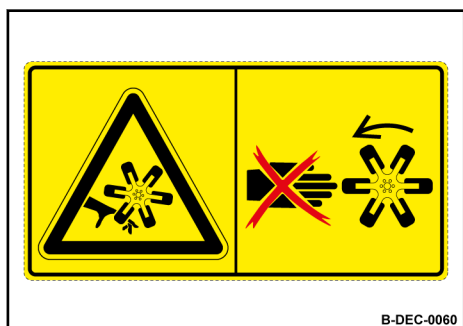

Warning sticker - Danger of cutting and getting caught by radiator fan

Fig. 11



Warning sticker - Danger of crushing

Fig. 12



Warning sticker - Follow operating instructions

Fig. 13

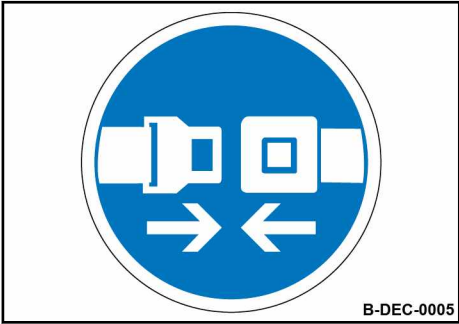

Instruction sticker - Always wear your seat belt

Fig. 14

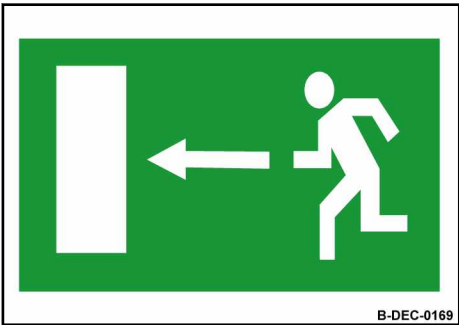

Information sticker - Emergency exit

Fig. 15

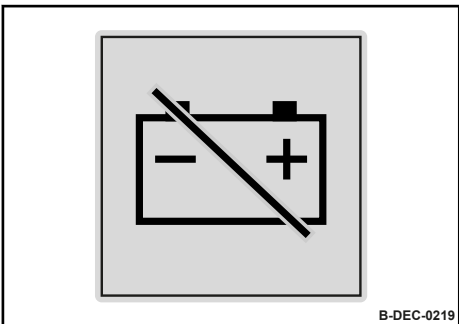

Information sticker - Disconnecting the battery

Fig. 16

General – Concerning your safety

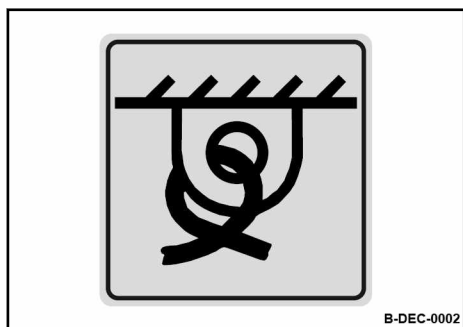

Information sticker - Lashing point

Fig. 17

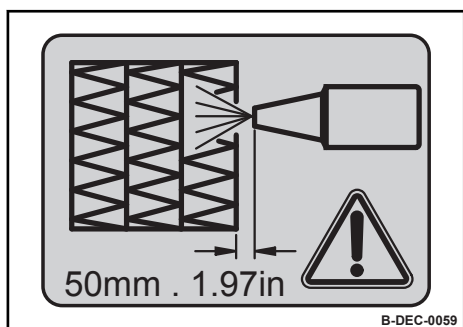

Information sticker - Clean cooling module

Fig. 18

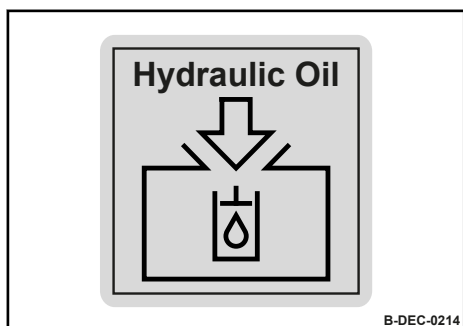

Information sticker - Filler opening for hydraulic oil

Fig. 19

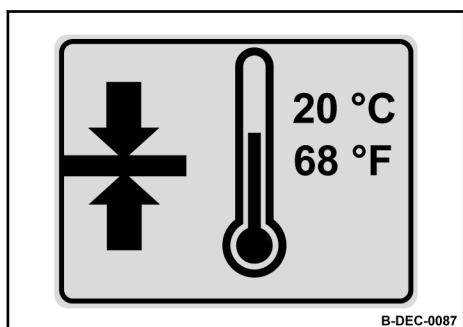

Information sticker - Hydraulic oil level

Fig. 20

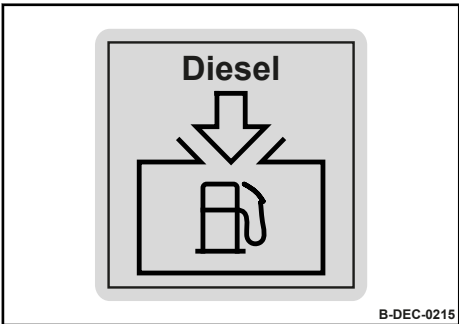

Information sticker - Filler opening for diesel

Fig. 21

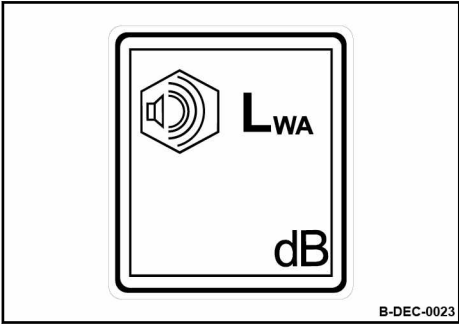

Information sticker - Guaranteed sound capacity level

Fig. 22

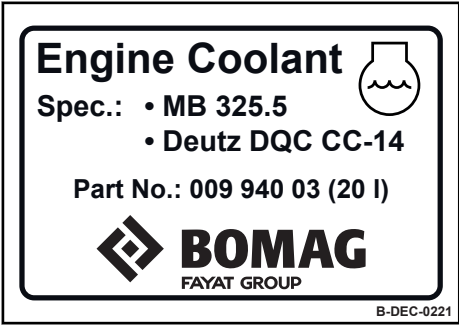

Information sticker - Coolant

Fig. 23

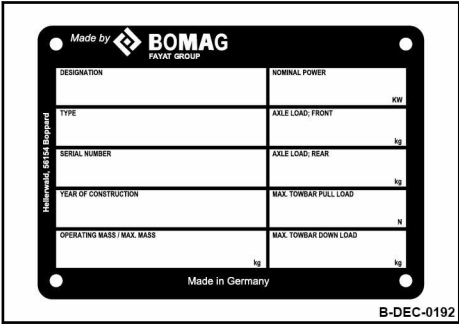

Machine type plate (example)

Fig. 24

1.3 Maintenance and repair

1.3.1 Notes on repair

1.3.1.1 General repair instructions



NOTICE!

Ensure strict cleanliness when performing repair work!

- No foreign objects should enter into open systems.
- Thoroughly clean the area around the affected components.
- Dry off wet locations with compressed air.

Before removing or disassembling parts, assembly groups, components or hoses mark these parts for easier assembly.

1.3.1.1.1 Repair notes for electrics

Electrics and welding



NOTICE!

Electrical components may get damaged by welding work!

- Always remove the main battery switch.
- Disconnect the batteries and connect negative and positive cables.
- Pull the plugs off the control units.

Always fasten the earth clamp of the welding unit in the immediate vicinity of the welding location.

When choosing the location for the earth clamp make sure that the welding current will not pass through joints or bearings.

Battery



Maintenance free batteries also need care. Maintenance free only means that the fluid level does not need to be checked.

Every battery has a self-discharge, which may, if not checked occasionally, even cause damage to the battery as a result of exhaustive discharge.

Exhausted batteries (batteries with formation of sulphate on the plates) are not covered under warranty!

- When removing a battery always disconnect the minus pole before the plus pole. When installing the battery connect the minus pole after the plus pole to avoid short circuits.
- Assemble the battery terminal clamps without force.

- Always keep battery poles and terminal clams clean to avoid high transition resistances when starting and the related development of heat.
- Make sure the battery is properly fastened in the vehicle.

Generator

- Before removing the generator you must disconnect the ground cable from the minus pole of the battery while the ignition is switched off. Do not disconnect the generator while the engine is running, because this may cause extremely high voltage peaks in the vehicle wiring system ("Load Dump"), which could possibly damage control units, radios or other electronic equipment.
- When removing the battery cable, the B+-nut underneath on the generator side may also be loosened. This nut must in this case be retightened.
- When connecting e.g. the battery cable to the terminal of the generator you must make sure that the polarity is correct (generator B+ to the + pole of the battery). Mixing up the polarities by mistake causes short circuit and damage to the rectifier elements - the generator will be out of function.
- The generator can only be operated with the battery connected. Under special conditions emergency operation without battery is permitted, the lifetime of the generator is in such cases especially limited.
- Plus and minus cables must be disconnected during rapid charging of the battery or electric welding on the vehicle.
- When cleaning the generator with a steam or water jet make sure not to direct the steam or water jet directly on or into the generator openings or ball bearings. After cleaning the generator should be operated for about 1 - 2 minutes to remove any deposits of water from the generator.

Starter

- So-called jump starting (using an additional external battery) without the battery connected is dangerous. When disconnecting the cables from the poles high inductivities (arcs, voltage peaks) may occur and destroy the electrical installation.
- For purposes like e.g. purging the fuel systems, starters may be operated for maximum 1 minute without interruption. Then you should wait for at least 30 minutes (cooling down) until trying again. During the 1 minute starting period this process should not be interrupted.
- Starter motors must not be cleaned with high pressure steam cleaning equipment.
- The contacts on starter terminals 30, 45, 50 must be protected against unintended shorting (jump protection).
- When replacing the starter the ring gear on the engine flywheel must be checked for damage and its number of teeth - if necessary replace the ring gear.
- Always disconnect the battery before starting assembly work in the starter area of the engine or on the starter itself.

1.3.1.1.2 Repair notes for hydraulics

Please note



Cleanliness is of utmost importance. Dirt and other contaminations must strictly be kept out of the system.

- Connections and screw fittings, filler neck covers and their immediate surrounding areas must be cleaned before removal.
- Before loosening hoses, pipe lines etc. relieve all pressure from the system.
- During repair work keep all openings closed with clean plastic plugs and caps.
- Never run pumps, motors and engine without oil or hydraulic oil.
- When cleaning hydraulic components take care not to damage any fine machined surfaces.
- Chemical and rubber dissolving cleansing agents may only be used to clean metal parts. Do not let such substances come in contact with rubber parts.
- Rinse of cleaned parts thoroughly, dry them with compressed air and apply anti-corrosion oil immediately. Do not install parts that show traces of corrosion.
- Avoid the formation of rust on fine machined parts caused by hand sweat.
- Use new O-rings or seal rings for reassembly.
- Use only hydraulic oil as sliding agent when reassembling. Do not use any grease!
- Use only the specified pressure gauges. Risk of damaging the pressure gauges under too high pressure.
- Check the hydraulic oil level before and after the work.
- Use only clean hydraulic oil in strict compliance with the specification in the operating and maintenance instructions to fill the hydraulic system.
- Check the hydraulic system for leaks, if necessary find and rectify the cause.
- Before taking new hydraulic components into operation fill these with hydraulic oil as specified in the operating and maintenance instructions.
- After changing a hydraulic component thoroughly flush, refill and bleed the complete hydraulic system.
- Perform pressure tests at operating temperature of the hydraulic oil (approx. 40 °C).
- After the completion of all tests perform a test run and then check all connections and fittings for leaks with the engine still stopped and the hydraulic system depressurized.

Before commissioning

- Fill the housings of hydraulic pumps and motors with hydraulic oil. Use only hydraulic oils according to the specification in the maintenance instructions.
- After changing a component flush the hydraulic system as described in the flushing instructions.

This as a preview PDF file from best-manuals.com



Download full PDF manual at best-manuals.com