

OPERATOR'S MANUAL

T6020

T6030

T6040

T6050

T6060

T6070

Elite

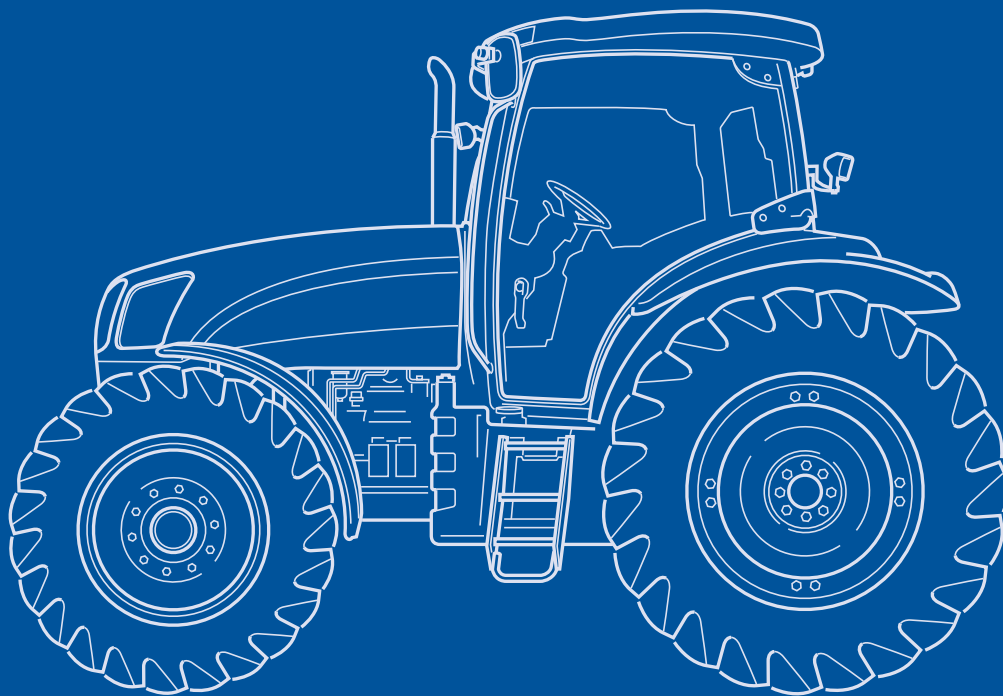

Print No. 84146211

2nd edition
English 08/08



OPERATOR'S MANUAL

T6020

T6030

T6040

T6050

T6060

T6070

Elite

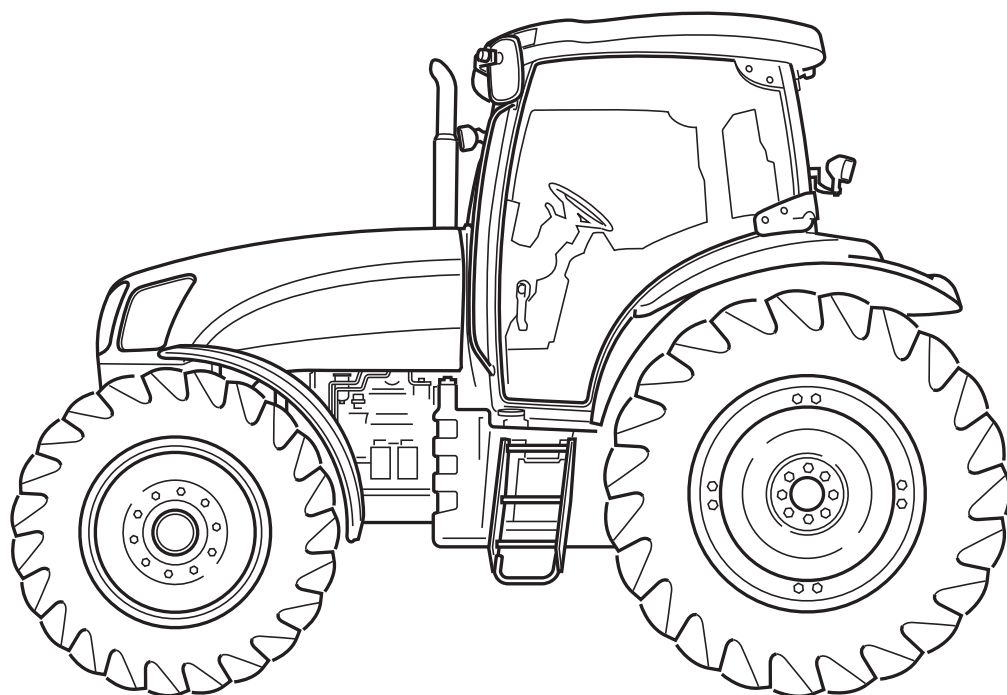

Print No. 84146211

2nd edition

English 08/08

 **NEW HOLLAND**
AGRICULTURE

CONTENTS

Title	Page
Section 1 - General Information and Safety	
To the Owner	1-1
Product Identification	1-3
Ecology and the Environment	1-7
Safety Precautions	1-8
Safety Decals	1-16
International Symbols	1-22
Airborne Noise Emission	1-23
Section 2 - Controls, Instruments and Operation	
Cab	2-6
Seats	2-26
Handbrake, Throttle and Foot Controls	2-31
Instrument Console	2-33
Analogue/Digital Instruments	2-36
Electro Command Transmission (16 x 16 and 17 x 16)	2-65
Differential Lock and Four Wheel Drive	2-82
Section 3 - Field Operation	
Important Information	3-2
Using Jump Leads (Booster Cables)	3-7
Starting the Engine	3-8
Stopping the Engine	3-11
Engine Power Management	3-13
Fast Steer	3-28
Rear Power Take-Off	3-30
Front Power Take-Off and Hydraulic Lift	3-51
Electronic Draft Control	3-59
Headland Turn Sequence	3-16
Remote Control Valves	3-71
Electro-Hydraulic Remote Control Valves	3-81
Additional Oil Supply for Remote Services	3-93
Using Remote Hydraulic Equipment	3-95
Three-point Linkage	3-97
Quick Hitch	3-104
Linkage Stabilisers	3-106
Drawbars and Towing Attachments	3-111
Hydraulic Trailer Brakes	3-128
Air-Operated Trailer Brakes	3-130
Front Wheel Track Adjustment	3-135
Rear Wheel Track Adjustment	3-141
Ballasting and Tyres	3-148

Section 4 - Lubrication and Maintenance

General Information	4-1
Guard Removal	4-7
Lubrication and Maintenance Chart	4-12
Servicing: When Warning Lights Illuminate	4-14
10-hour/daily service	4-18
50-hour service	4-20
100-hour service	4-31
300-hour service	4-31
600-hour service	4-35
1200-hour/12 month service	4-42
1200-hour/24 month service	4-49
Every 3 years	4-55
General Maintenance - as required	4-56
Protecting the electrical system	4-72
Storing the tractor	4-73

Section 5 - Fault Finding

Introduction	5-1
Engine	5-2
Transmission - 16 x 16 (17 x 16) Electro Command	5-5
Hydraulics	5-6
Three-point lift	5-7
Brakes	5-8
Cab	5-8
Electrical	5-9

Section 6 - Accessories

Auxiliary Headlights	6-2
Battery Isolator Switch	6-2
Loader Subframe and Control Valve (Joystick)	6-3

Section 7 - Specification

General Dimensions 7-2
Vehicle Weights 7-10
Lubricant and Fluid Capacities 7-11
Engine 7-12
Fuel System 7-12
Cooling System 7-13
Transmission Options 7-13
Brakes 7-14
Rear Power Take-Off 7-14
Front Power Take-Off 7-15
Steering 7-15
Maximum Operating Angle 7-15
Hydraulic System 7-16
Rear Three-Point Hitch 7-16
Remote control valves 7-19
Front Three-Point Hitch 7-19
Front Remote Valves 7-20
Electrical Equipment 7-20
Hardware Torque Tables 7-21

Section 8 - First 50-hour Service Forms 8-1

Section 9 - Index 9-1



SECTION 1

GENERAL INFORMATION AND SAFETY

TO THE OWNER

GENERAL

This Manual has been prepared to assist you in the correct procedure for running-in, driving and operating and for the maintenance of your new tractor. Read this Manual carefully. Your tractor is intended for use in normal and customary agricultural applications.

If at any time you require advice concerning your tractor, do not hesitate to contact your authorised dealer. He has factory trained personnel, genuine manufacturers' parts and the necessary equipment to carry out all your service requirements.

Your tractor has been designed and built to give maximum performance, economy and ease of operation under a wide variety of operating conditions. Prior to delivery, the tractor was carefully inspected, both at the factory and by your dealer to ensure that it reaches you in optimum condition. To maintain this condition and ensure trouble-free operation, it is important that the routine services, as specified in Section 4 of this Manual, are carried out at the recommended intervals.

OPERATORS MANUAL STORAGE

A storage pocket for the Operators Manual can be found on the rear of the seat. The manual should be kept in this pocket at all times when not in use.

SAFETY

Pages 1-8 to 1-15 inclusive list the precautions to be observed to ensure your safety and the safety of others. Read the safety precautions and follow the advice offered **before** operating the tractor.

CLEANING THE TRACTOR

Your tractor is a state-of-the-art machine with sophisticated, electronic controls. This should be borne in mind when cleaning the tractor, particularly if using a high pressure washer. Even though every precaution has been taken to safeguard electronic components and connections, the pressure generated by some of these machines is such that complete protection against water ingress cannot be guaranteed.

When using a high pressure washer, do not stand too close to the tractor and avoid directing the jet at electronic components, electrical connections, breathers, seals, filler caps, etc. Never direct a cold water jet at a hot engine or exhaust.

ELECTRO-MAGNETIC INTERFERENCE (EMC)

This tractor complies strictly with the European Regulations on electro-magnetic emissions. However, interference may arise as a result of add-on equipment which may not necessarily meet the required standards. As such interference can result in serious malfunction of the unit and/or create unsafe situations, you must observe the following:

- Ensure that each piece of non-New Holland equipment fitted to the tractor bears the CE mark.
- The maximum power of emission equipment (radio, telephones, etc.) must not exceed the limits imposed by the national authorities of the country where you use the tractor.
- The electro-magnetic field generated by the add-on system should not exceed 24 V/m at any time and at any location in the proximity of electronic components.

Failure to comply with these rules will render the New Holland warranty null and void.

FIRST 50 HOUR SERVICE

In Section 8, at the back of this Manual, you will find the 50-hour service reports.

After you have operated the tractor for 50 hours, take your tractor, together with this Manual, to your dealer. He will then perform the factory recommended 50 hour service and complete the service report sheets (pages 8-1 and 8-3). The first sheet (page 8-1) is the dealer's copy and should be removed by the dealer after the service has been carried out. The second sheet (page 8-3) is your copy of the service performed. **Ensure that you and the dealer sign both copies.**

SERVICE PARTS

It should be pointed out that genuine parts have been examined and approved by the Company. The installation and/or use of 'non-genuine' products could have negative effects upon the design characteristics of your tractor and thereby affect its safety. The Company is not liable for any damage caused by the use of 'non-genuine' parts and accessories. Only genuine New Holland replacement parts should be used. The use of non-genuine parts may invalidate legal approvals associated with this product.

It is prohibited to carry out any modifications to the tractor unless specifically authorised, in writing, by the After Sales Service department of the Company.

WARRANTY

Your tractor is warranted according to legal rights in your country and the contractual agreement with the selling dealer. No warranty shall, however, apply if the tractor has not been used, adjusted and maintained according to the instructions given in the Operator's Manual.

PRODUCT IDENTIFICATION

The tractor and major components are identified using serial numbers and/or manufacturing codes. Tractor identification data must be supplied to the dealer when requesting parts or service and will also be needed to aid in identifying the tractor if it is ever stolen.

The following provides the locations of the identification data.

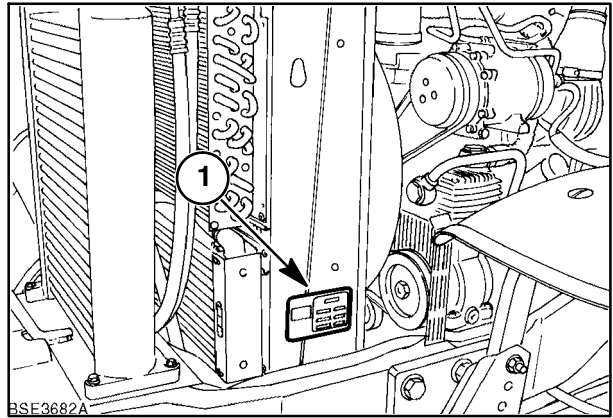

1

Vehicle Identification Plate

The vehicle identification plate, (1) Figure 1 is located on the left-hand radiator support. Record the information on the sample identification plate provided below.

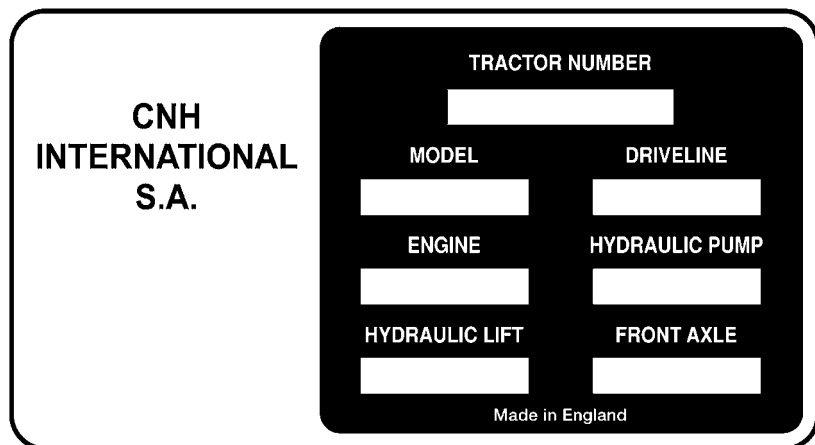

2

Tractor Identification

The serial number and model identification information is stamped on the top of the front support (1). These numbers are also repeated on the vehicle identification plate reproduced above.

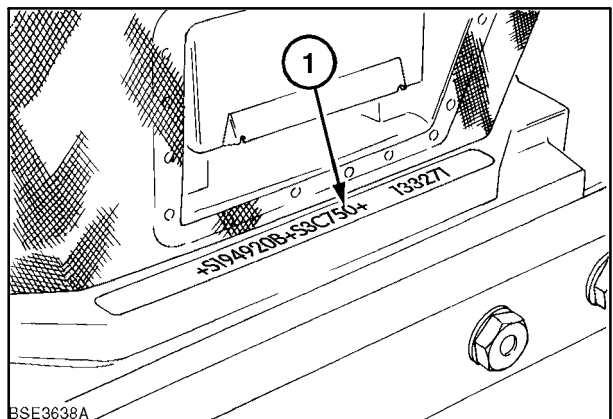

3

SECTION 1 - GENERAL INFORMATION AND SAFETY

Engine Information

The engine serial number and date of manufacture are stamped on the right-hand side of engine block (1), below the manifold. Record the number below.

Engine Serial No. _____

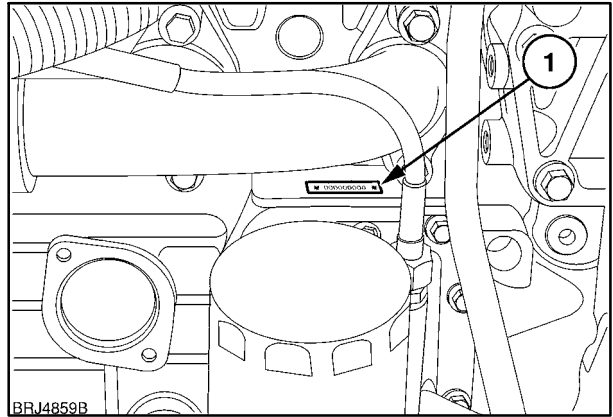

4

The engine serial number is repeated on the information plate located on the left side of the engine oil pan.

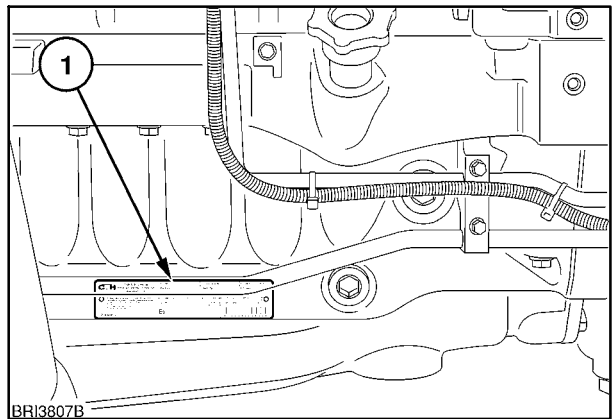

5

Further information relating to engine adjustments and emission level compliance are also shown on the engine information plate.

NOTE: The details displayed on the engine information plate may change according to the country in which the tractor is sold.

	CNH U.K. Limited IMPORTANT ENGINE INFORMATION Assembled in UK	CID/Litre	Engine Serial No.	FEL g/kW-hr	EPA
	This engine conforms to Regulations for large non-road compression ignition diesel engines. This engine is designed to operate on commercially available diesel fuel. When making adjustments set parking brake and block wheels.	E.P.A. Family	Model Type	NOx+NMHC	
Advised BHP/kW		rpm	Engine Model	PM	
Valve Lash Cold (mm)		Inlet	Exh.	Initial Injection Timing	BTDC
Low Idle		rpm	Fuel rate @ advertised power		mm ³ /Stroke
Date of Manufacture				 3 8 1 9 3 1 8 7 5 2 0 6 7 8	

SECTION 1 - GENERAL INFORMATION AND SAFETY

Driveline Identification

The serial number plate (1) is located on top of the transmission casing. Access to the number can be gained by removing the plate in the floor of the cab as shown in the illustration. This number is repeated on the vehicle identification plate. Record the information below for quick reference.

Driveline Serial No. _____

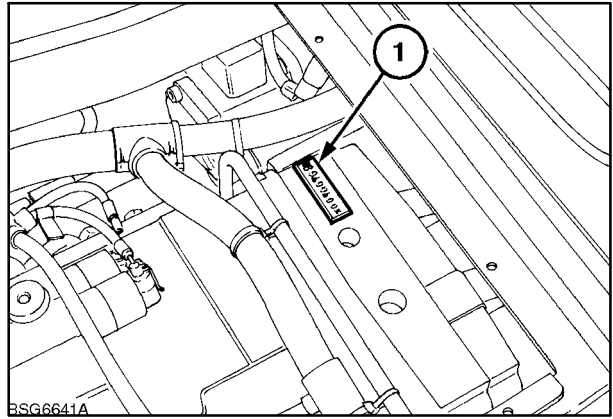

6

Cab Identification

The cab serial number and other information is on the OECD certification plate. This plate can be found on the right-hand side of the cab trim panel, below the rear window. Record the cab serial number below for quick reference.

Cab Serial No. _____

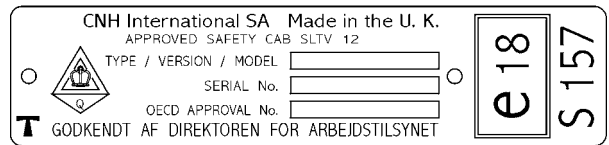

7

TRANSPORTING TOWED EQUIPMENT AT SAFE SPEEDS

Product Identification Number Plate

The Product Identification Number plate provides important information on tractor and towed equipment weight combinations. This plate can be found on the right-hand side of the cab exterior trim panel, below the rear window.

The figures shown are the maximum permissible vehicle and towing weights and should not be exceeded, to do so may affect the safe operation of the tractor. See Drawbars and Towing Attachments in Section 3.

CNH International SA		Made in the U.K.		A B S
TYPE				
No.				C O E F F
IDENTIFICATION No.				
TOTAL PERMISSIBLE MASS :		KG	<input type="checkbox"/>	
PERMISSIBLE FRONT AXLE LOAD :		KG		
PERMISSIBLE REAR AXLE LOAD :		KG		
<input type="radio"/> PERMISSIBLE TOWABLE MASS			<input type="radio"/>	
UNBRAKED TOWABLE MASS :		KG		
INDEPENDENTLY - BRAKED :		KG		
INERTIA - BRAKED :		KG		
ASSISTED BRAKE :		KG		

ECOLOGY AND THE ENVIRONMENT

Soil, air and water are vital factors of agriculture and life in general. Where legislation does not yet rule the treatment of some of the substances which are required by advanced technology, common sense should govern the use and disposal of products of a chemical and petrochemical nature.

The following are recommendations which may be of assistance:

- Become acquainted with and ensure that you understand the relative legislation applicable to your country.
- Where no legislation exists, obtain information from suppliers of oils, filters, batteries, fuels, anti freeze, cleaning agents, etc., with regard to their effect on man and nature and how to safely store, use and dispose of these substances. Agricultural consultants will, in many cases, be able to help you as well.

HELPFUL HINTS

1. Avoid filling tanks using unsuitable containers or inappropriate pressurised fuel delivery systems which may cause considerable spillage.
2. In general, avoid skin contact with all fuels, oils, acids, solvents, etc. Most of them contain substances which can be harmful to your health.
3. Modern oils contain additives. Do not burn contaminated fuels and/or waste oils in ordinary heating systems.
4. Avoid spillage when draining off used engine coolant mixtures, engine, gearbox and hydraulic oils, brake fluids, etc. Do not mix drained brake fluids or fuels with lubricants. Store them safely until they can be disposed of in a proper way to comply with local legislation and available resources.
5. Modern coolant mixtures, i.e. antifreeze and other additives, should be replaced every two years. They should not be allowed to get into the soil but should be collected and disposed of safely.
6. Do not open the air-conditioning system yourself. It contains gases which should not be released into the atmosphere. Your dealer or air conditioning specialist has a special extractor for this purpose and will have to recharge the system anyway.
7. Repair any leaks or defects in the engine cooling or hydraulic system immediately.
8. Do not increase the pressure in a pressurised circuit as this may lead to the components exploding.
9. Protect hoses during welding as penetrating weld splatter may burn a hole or weaken them, causing the loss of oils, coolant, etc.

SAFETY PRECAUTIONS

A careful operator is the best operator. Most accidents can be avoided by observing certain precautions. To help prevent accidents, read and take the following precautions **before** driving, operating or servicing the tractor. Equipment should be operated only by those who are responsible and instructed to do so.

PRECAUTIONARY STATEMENTS

Throughout this Manual you will see text, preceded by the words **NOTE**, **ATTENTION**, **IMPORTANT**, **CAUTION**, **WARNING** or **DANGER**. Such text has the following significance:

MACHINE SAFETY

NOTE: This text stresses a correct operating technique or procedure.

ATTENTION: This text warns the operator of potential machine damage if a certain procedure is not followed.

IMPORTANT: This text informs the reader of something that he needs to know to prevent minor machine damage if a certain procedure is not followed.

PERSONAL SAFETY



The word **CAUTION** is used where a safe behavioural practice, according to operating and maintenance instructions and common safety practices will protect the operator and others from accident involvement.



The word **WARNING** denotes a potential or hidden hazard which could possibly cause serious injury. It is used to warn operators and others to exercise due care and attention to avoid a surprise accident with machinery.



The word **DANGER** denotes a forbidden practice in connection with a serious hazard.

Failure to follow the **CAUTION**, **WARNING** and **DANGER** instructions may result in serious bodily injury or even death.

THE TRACTOR

1. Read the Operator's Manual carefully before using the tractor. Lack of operating knowledge can lead to accidents.
2. Only allow properly trained and qualified persons to operate the tractor.
3. To prevent falls, use the handrails and step plates when getting on and off the tractor. Keep steps and platform clear of mud and debris.
4. Replace all missing, illegible or damaged safety decals.
5. Keep safety decals free of dirt or grime.

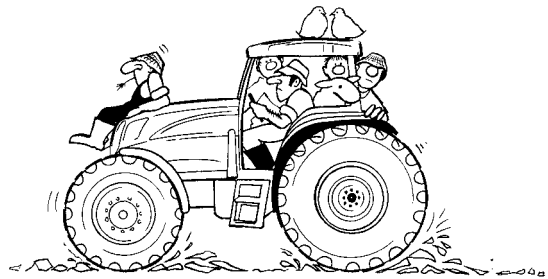

6. Do not permit anyone but the operator to ride on the tractor except for driver training or instruction. When used for these purposes an additional seat may be fitted in the cab. Passengers should not be carried on the tractor at any time.
7. Keep children away from the tractor and farm machinery at all times.
8. Do not modify or alter or permit anyone else to modify or alter the tractor or any of its components or any tractor function without first consulting your dealer.
9. Install all guards before starting the engine or operating the tractor.

DRIVING THE TRACTOR

1. Always sit in the driver's seat while starting or driving the tractor.
2. When driving on public roads, have consideration for other road users. Pull in to the side of the road occasionally to allow any following traffic to pass. Do not exceed the legal speed limit set in your country for agricultural tractors.
3. Use a rotating beacon and/or Slow Moving Vehicle warning when driving on public roads to indicate that the vehicle is slow moving and is a possible hazard.
4. Dip the tractor lights when meeting a vehicle at night. Make sure the lights are adjusted to prevent blinding the driver of an oncoming vehicle.
5. Reduce speed before turning or applying the brakes. Brake both wheels simultaneously when making an emergency stop. Ensure that both brake pedals are locked together when travelling at road speeds or when on public roads to ensure correct operation of trailer brakes, balanced operation of the tractor brakes and four wheel braking (4WD tractors only).



6. On four wheel drive tractors, the drive to the front axle is automatically engaged, to provide four wheel braking, when both footbrakes are applied. Owners should be aware of the effectiveness of four wheel braking which greatly enhances braking performance. Appropriate care should be exercised during fierce braking.
7. Use extreme caution and avoid hard application of the tractor brakes when towing heavy loads at road speeds.

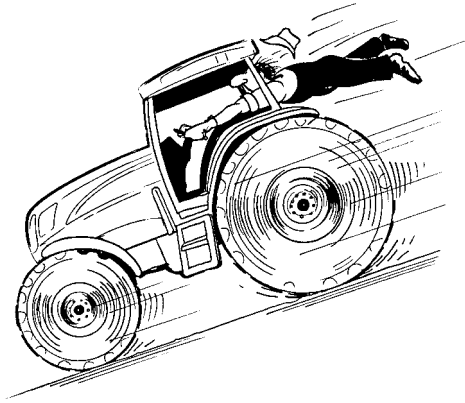

8. Keep the tractor in the same gear when going downhill as would be used when going uphill. Do not coast or freewheel down hills.
9. For safe operation any towed vehicle whose total weight exceeds that of the towing tractor must be equipped with a braking system that complies with the legal requirements of that country.
10. Never apply the differential lock when turning. When engaged, the differential lock will prevent the tractor from turning.
11. Always check overhead clearance, especially when transporting the tractor. Watch where you are going, especially at row ends, on roads and around trees and low overhanging obstacles.
12. To avoid overturns, drive the tractor with care and at speeds compatible with safety, especially when operating over rough ground, when crossing ditches or slopes and when turning corners.

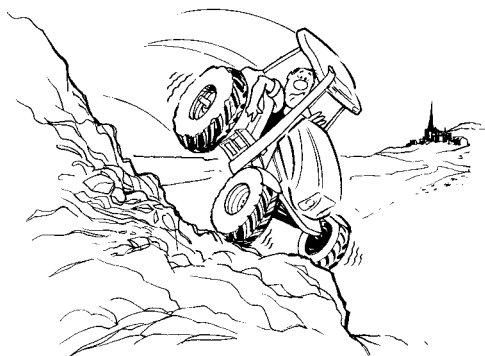

13. Use extreme caution when operating on steep slopes.
14. If the tractor becomes stuck or the tyres are frozen to the ground, reverse the tractor out to prevent overturning.

OPERATING THE TRACTOR

1. Apply the parking brake, place the P.T.O. control in the 'OFF' position, the lift control lever in the down position, the remote control valve levers in the neutral position and the transmission levers in neutral before starting the tractor.
2. Do not start the engine or operate controls (other than externally located hydraulic lift or P.T.O. switches, if fitted) while standing beside the tractor. Always sit in the tractor seat when starting the engine or operating the controls.
3. Do not bypass the transmission and P.T.O. neutral start switches. Consult your authorised dealer if your neutral start controls malfunction. Use jump leads only in the recommended manner. Improper use can result in a tractor runaway.



4. Avoid accidental contact with the gear shift levers while the engine is running. Unexpected tractor movement can result from such contact.
5. Do not get off the tractor while it is in motion.
6. If the power steering or engine ceases operating, stop the tractor immediately as the tractor will be more difficult to control.
7. Before leaving the tractor, park the tractor on level ground, apply the parking brake, lower attached implements to the ground, disengage the P.T.O. and stop the engine.

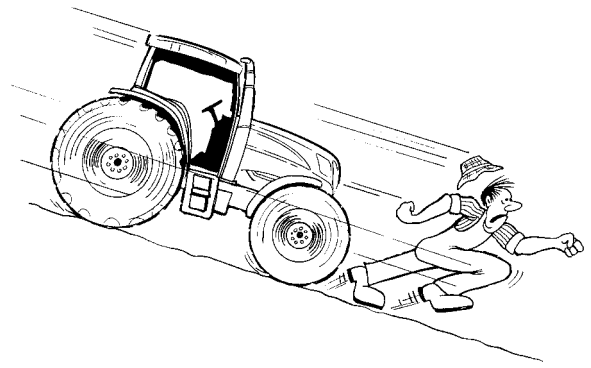

8. Do not park the tractor on a steep incline.
9. The cab is designed to provide the minimum noise level at the operator's ears and meets or exceeds applicable standards in this respect. However, noise (sound pressure level) in the workplace can exceed 85 dB(A) when working between buildings or in confined spaces, with cab windows open. Therefore, it is recommended that operators wear suitable ear protectors when operating in high noise level conditions.

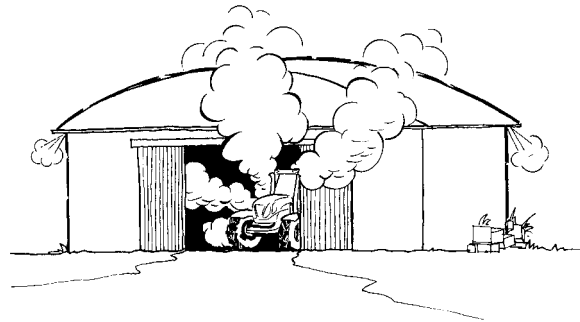

10. Do not run the tractor engine in an enclosed building without adequate ventilation. Exhaust fumes are toxic and can cause death.
11. Pull only from the pick-up hitch, swinging drawbar or the lower link drawbar in the lowered position. Use only a drawbar pin that locks in place. Pulling from the tractor rear axle or any point above the axle may cause the tractor to overturn.

12. Always select Position Control when attaching equipment and when transporting equipment. Be sure hydraulic couplers are properly mounted and will disconnect safely in case of accidental detachment of the implement.

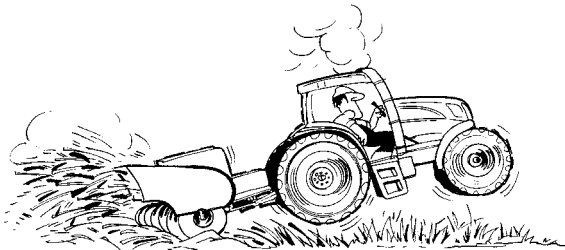

13. If the front end of the tractor tends to rise when heavy implements are attached to the three-point hitch, install front end or front wheel weights. Do not operate the tractor with a light front end.
14. Engage the clutch slowly when driving out of a ditch, gully or up a steep hillside. Disengage the clutch promptly if the front wheels rise off the ground.
15. Ensure any attached equipment or accessories are correctly installed, are approved for use with the tractor, do not overload the tractor and are operated and maintained in accordance with the instructions issued by the equipment or accessory manufacturer.
16. Remember that your tractor, if abused or incorrectly used, can be dangerous and become a hazard both to the operator and to bystanders. Do not overload or operate with attached equipment which is unsafe, not designed for the particular task or is poorly maintained.
17. Do not leave equipment in the raised position when the vehicle is stopped or unattended.
18. Do not drive equipment near open fires.
19. Always wear a protective mask when working with toxic spray chemicals. Follow the directions on the chemical container.

OPERATING THE P.T.O.

1. When operating P.T.O.- driven equipment, shut off the engine, switch off the P.T.O. and wait until the P.T.O. stops before getting off the tractor and disconnecting the equipment.



2. Do not wear loose clothing when operating the power take-off or especially when near rotating equipment.
3. When operating stationary P.T.O.-driven equipment, always apply the tractor parking brake and block the rear wheels front and back.



4. To avoid injury, do not clean, adjust, unclog or service P.T.O. driven equipment when the tractor engine is running. Ensure that the P.T.O. is switched off.
5. Make sure the P.T.O. guard is in position at all times and always replace the P.T.O. cap when the P.T.O. is not in use.

SERVICING THE TRACTOR



1. The cooling system operates under pressure which is controlled by the expansion tank cap. It is dangerous to remove the cap while the system is hot. Always turn the cap slowly to the first stop and allow the pressure to escape before removing the cap entirely. Never remove the cap from the top of the radiator unless the expansion tank pressure cap has first been removed.
2. Do not smoke while refuelling the tractor. Keep any type of open flame away.
3. Keep the tractor and equipment, particularly brakes and steering, maintained in a reliable and satisfactory condition to ensure your safety and comply with legal requirements.
4. To prevent fire or explosion, keep open flames away from battery or cold weather starting aids. To prevent sparks which could cause explosion, use jumper cables according to instructions.
5. Do not attempt to service the air conditioning system. It is possible to be severely frost bitten or injured by escaping refrigerant. Special equipment and instruments are required to service the air conditioning system. See your authorised dealer for service.
6. Stop the engine before performing any service on the tractor.
7. Hydraulic fluid and fuel oil in the injection system operate under high pressure. Escaping hydraulic fluid or fuel oil under pressure can penetrate the skin causing serious injury.

Unqualified persons should not remove or attempt to adjust a pump, injector, nozzle or any other part of the fuel injection or hydraulic systems. Failure to follow these instructions can result in serious injury.

- Do **not** use your hand to check for leaks. Use a piece of cardboard or paper to search for leaks.
- Stop the engine and relieve pressure before connecting or disconnecting lines.

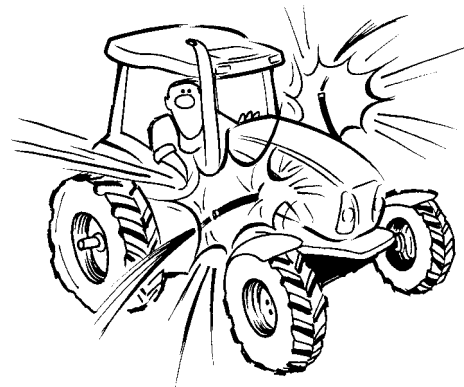

- Tighten all connections before starting the engine or pressurising lines.
 - If fluid is injected into the skin obtain medical attention immediately or gangrene may result.
8. Do not modify or alter or permit anyone else to modify or alter the tractor or any of its components or any tractor function without first consulting an authorised dealer.
 9. Continuous long term contact with used engine oil may cause skin cancer. Avoid prolonged contact with used engine oil. Wash skin promptly with soap and water.
 10. Keep equipment clean and properly maintained.
 11. Dispose of all drained fluids and removed filters properly.
 12. Tractor wheels are very heavy. Handle with care and ensure, when stored, that they cannot topple and cause injury.

PREVENTION OF FIRE OR EXPLOSION

1. Due to the flammable nature of some crop materials, the risk of tractor fire can be high. This risk can be minimised by frequent removal of accumulated crop material from the tractor. If oil leaks appear, correct the fault by re-torquing the bolts or replacing the gaskets as necessary.
2. When operating in flammable crop conditions, check and remove all trash or debris from the tractor each day, especially around the engine area and exhaust system.

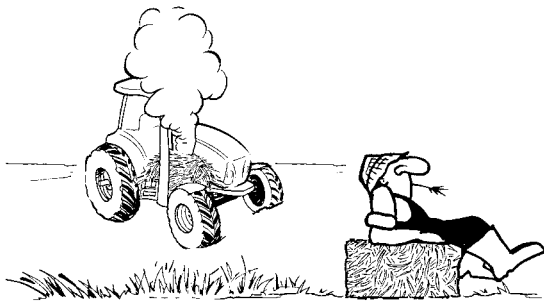

3. Sparks or open flame can cause the hydrogen gas in a battery to explode. To prevent an explosion carry out the following:
 - When disconnecting the battery cables, remove the negative (-) cable first. When re-connecting the battery cables, connect the negative (-) cable last.
 - When using jumper cables to start the engine, use only the procedure shown in Section 3 of this manual.
 - Do not short circuit the battery terminals with a metal object.
 - Do not weld, grind or smoke near a battery.
4. Periodically check the tractor electrical system for loose connections or frayed insulation. Repair or replace any damaged parts.

5. Sparks from the electrical system or engine exhaust can cause an explosion and fire. Before you operate the tractor in an area with flammable dust or vapours, use a good ventilation system the remove the flammable dust or vapours.
6. Use a non flammable cleaning solvent when cleaning parts on the tractor.
7. A fire can cause injury or death. It is advisable to have a fire extinguisher near or on the tractor when operating in conditions where a fire may occur. Ensure fire extinguishers are serviced according to the manufacturers instructions.
8. If a fire extinguisher has been used, always recharge or replace the extinguisher before operating the tractor in conditions where a fire may occur.
9. **DO NOT** store flammable materials (oil soaked rags etc.) on the tractor.

DIESEL FUEL

1. Under no circumstances should gasoline, alcohol or blended fuels be added to diesel fuel. These combinations can create an increased fire or explosive hazard. In a closed container such as a fuel tank these blends are more explosive than pure gasoline. Do not use these blends.
2. Never remove the fuel cap or refuel with the engine running or hot.
3. Do not smoke while refuelling the tractor or when standing near fuel. Keep any type of open flame away.
4. Maintain control of the fuel filler pipe nozzle when filling the tank.
5. Do not fill the fuel tank to capacity. Fill only to the bottom of the filler neck to allow room for expansion.
6. Wipe up spilled fuel immediately.
7. Always tighten the fuel tank cap securely.
8. If the original fuel tank cap is lost, replace it with an approved cap. A non-approved cap may not be safe.
9. Never use fuel for cleaning purposes.
10. Arrange fuel purchases so that summer grade fuels are not held over and used in the winter.



**WHENEVER YOU SEE THIS SYMBOL  IT MEANS: ATTENTION!
BECOME ALERT! YOUR SAFETY IS INVOLVED!**

OPERATOR PROTECTIVE STRUCTURE



Your machine is equipped with an operator Protective Structure, such as: a Roll Over Protective Structure (ROPS) or Falling Object Protective Structure (FOPS) or Cab with ROPS. A ROPS may be a cab frame or a two-posted or four-posted structure used for the protection of the operator to minimise the possibility of serious injury.

The Protective Structure is a special safety component of your machine.

DO NOT attach any device to the Protective Structure for pulling purposes. DO NOT drill holes to the Protective Structure.

The Protective Structure and interconnecting components are a certified system. Any damage, fire, corrosion or modification will weaken the structure and reduce your protection. If this occurs, the **Protective Structure MUST be replaced** so that it will provide the same protection as a new Protective Structure. Contact your dealer for Protective Structure inspection and replacement.

After an accident, fire, tip or roll over, the following **MUST** be performed by a qualified technician before returning the machine to field or job site operation.

- The Protective Structure **MUST be replaced**.
- The mounting or suspension for the Protective Structure, operator seat and suspension, seat belts and mounting components and wiring within the operator's protective system **MUST** be carefully inspected for damage.
- All damaged parts **MUST be replaced**.

DO NOT WELD, DRILL HOLES, ATTEMPT TO STRAIGHTEN OR REPAIR THE PROTECTIVE STRUCTURE. MODIFICATION IN ANY WAY CAN REDUCE THE STRUCTURAL INTEGRITY OF THE STRUCTURE WHICH COULD CAUSE DEATH OR SERIOUS INJURY IN THE EVENT OF FIRE, TIP, ROLL OVER, COLLISION OR ACCIDENT.

SAFETY DECALS

The decals reproduced on the following pages were installed on your tractor in the positions indicated in the drawings below. They are intended for your safety and for those working with you. Please take this Manual and walk around your tractor, noting the location of the decal and their significance. Review the decals and operating instructions detailed in this Manual with the machine operators. Keep the decals clean and legible. If they become damaged or illegible, obtain replacements from your authorised dealer.

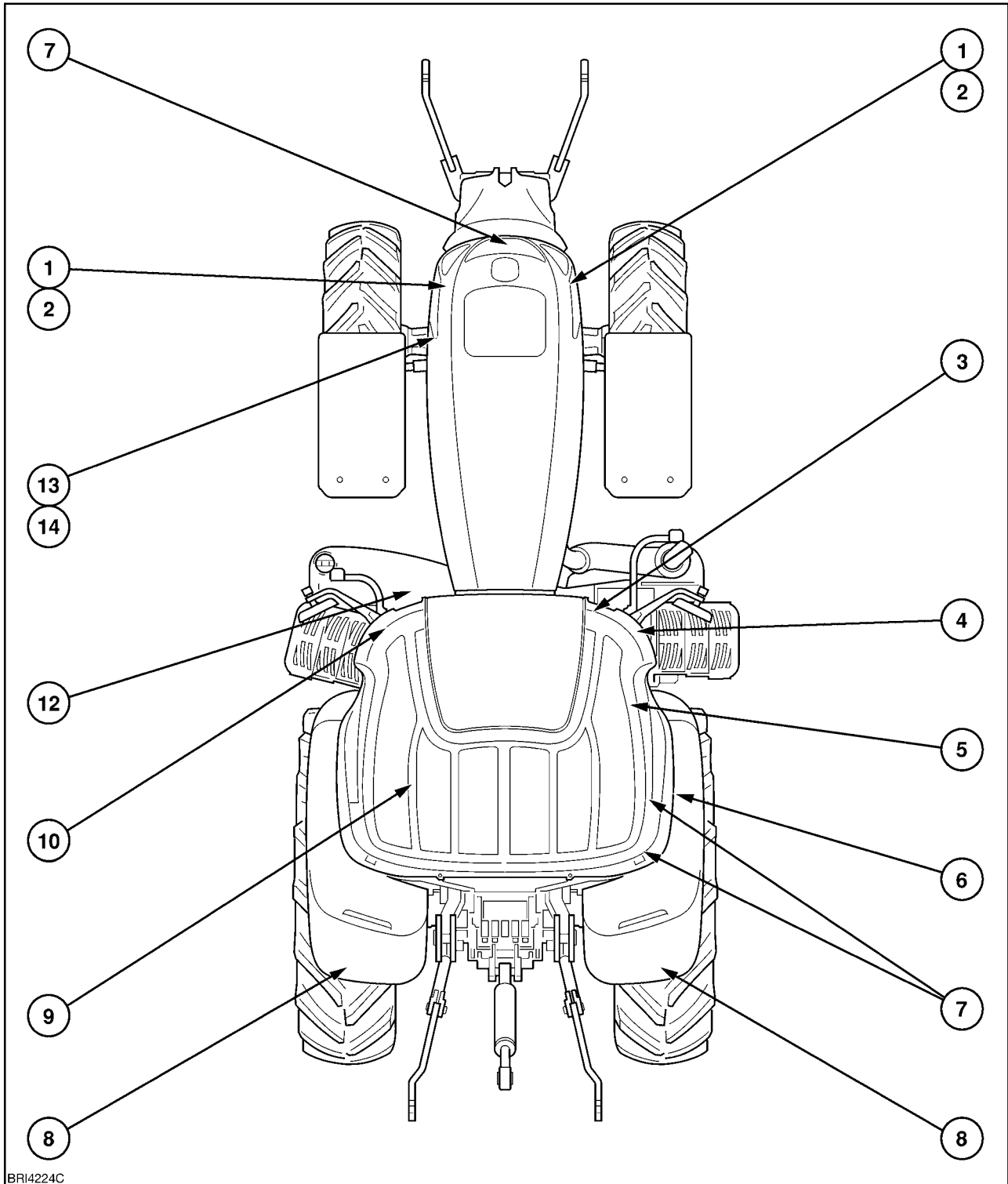

1. Location:
Left and right-hand side of fan guard

To prevent serious injury, keep hands and clothing away from rotating fan and drive belt.

Part No. 81871830

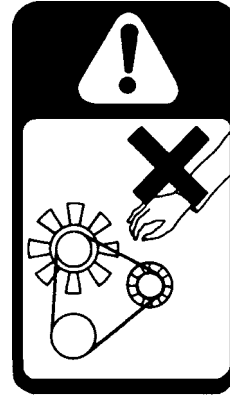

2. Location:
Left and right-hand side of radiator

Warning! Pressurised cooling system. Allow to cool then remove cap carefully. Using a cloth, turn cap to the first stop and allow pressure to subside before removing cap completely.

Part No. 5194556

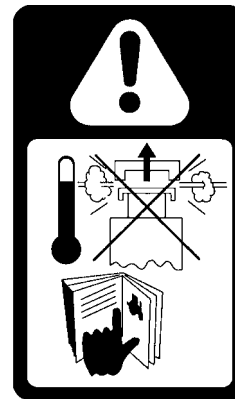

3. Location:
Radar sensor mounting bracket

To avoid possible eye damage from micro-wave signals emitted by the radar sensor, do not look directly into the sensor face.

Part No. 82002071

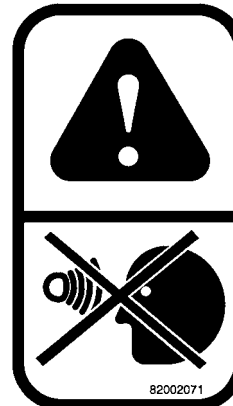

**4. Location:
Top of battery**

Danger! Corrosive acid. Explosive gas. Wear eye protection. Avoid producing sparks. See Operator's Manual.

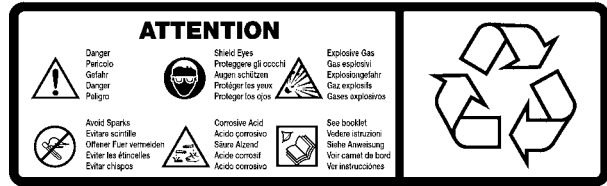

**5. Location:
Right-hand 'A' pillar inside cab**

Warning! De-activate Fast Steer system before travelling on the highway. Read Operator's Manual.

Part No. 87331567

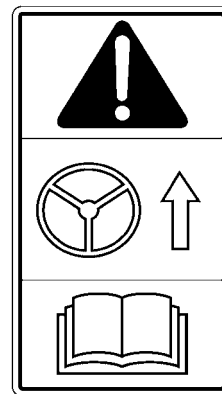

**6. Location:
Front of right-hand control console**

Caution! Always use grab handles when entering or leaving the platform/cab

Part No. 81871702



7. Location:
Hydraulic accumulator/s

Caution! High pressure hydraulic/gas accumulator.
Follow service manual instructions for removal or
repair.

Part No. 82029751

NOTE: The number and position of the hydraulic
accumulators may change according to tractor
specification.

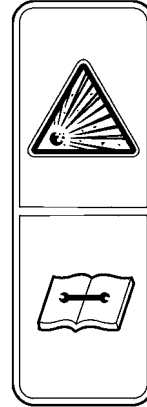

8. Location:
**Rear of both fenders (with external power
controls only)**

To avoid injury, do not stand on the implement or
between the implement and tractor while operating
the external lift or P.T.O. controls.

Part No. 83982553



9. Location:
Parking Brake Lever

Read the Operator's Manual.

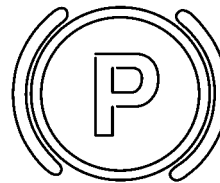

10.Location:

Left-hand 'A' pillar inside the cab

Multi-function decal

General Warning.

Read and understand all the warning notes printed in the Operator's Manual. In particular, read the General Information and Safety section in the Operator's Manual.

Towing the Tractor.

Caution! Rear the Operator's Manual before attempting to tow the tractor.

In an Overturn.

In an overturn, hold on tightly to the steering wheel. Do not attempt to jump out.

Part No. 87345805

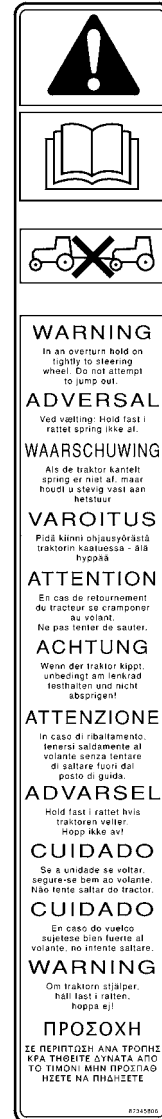

12.Location:

Top of toolbox

Do not stand on toolbox.

Part No. 82010947

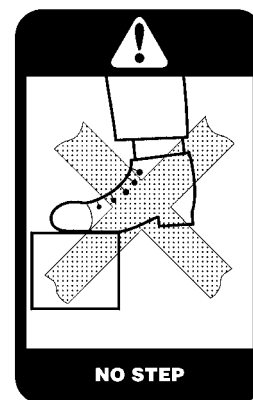

13.Location:
Air conditioning compressor

Warning! Fluid under pressure, do not disconnect any lines. Read Operator's Manual.

Part No. 83946774



14.Location:
Left-hand side of radiator

Warning! Heater Grid cold start aid. Do not use ether or risk of explosion will occur.

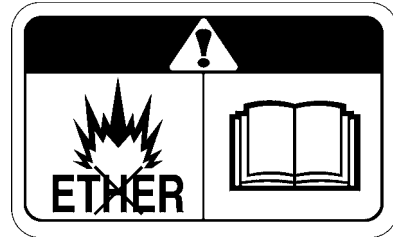

Part No. 87802167



BSG6600A

INTERNATIONAL SYMBOLS

As a guide to the operation of your tractor, various universal symbols have been utilised on the instruments, controls, switches, and fuse box. The symbols are shown below with an indication of their meaning.

	Thermostart starting aid		Radio		P.T.O.		Position Control
	Alternator charge		Keep alive memory		Transmission in neutral		Draft Control
	Fuel level		Turn signals		Creeper gears		Accessory socket
	Automatic Fuel shut-off		Turn signals -one trailer		Slow or low setting		Implement socket
	Engine speed (rev/min x 100)		Turn signals -two trailers		Fast or high setting		%age slip
	Hours recorded		Front wind-screen wash/wipe		Ground speed		Hitch raise (rear)
	Engine oil pressure		Rear wind-screen wash/wipe		Differential lock		Hitch lower (rear)
	Engine coolant temperature		Heater temperature control		Rear axle oil temperature		Hitch height limit (rear)
	Coolant level		Heater fan		Transmission oil pressure		Hitch height limit (front)
	Tractor lights		Air conditioner		FWD engaged		Hitch disabled
	Headlamp main beam		Air filter blocked		FWD dis-engaged		Hydraulic and transmission filters
	Headlamp dipped beam		Parking brake		Warning!		Remote valve extend
	Work lamps		Brake fluid level		Hazard warning lights		Remote valve retract
	Stop lamps		Trailer brake		Variable control		Remote valve float
	Horn		Roof beacon		Warning! Corrosive substance		Malfunction! See Operator's Manual
			Warning! Pressurised! Open carefully		Malfunction! (alternative symbol)		

AIRBORNE NOISE EMISSION

In accordance with E.E.C. directives, the noise levels of tractors covered by this manual are as follows:

Tractors with Cabin and Fixed Windscreen with Air Cleaner Extraction System

	Transmission	Noise level at operators ear		Drive by noise level
		Closed ⁽¹⁾ Annex II*	Open ⁽²⁾ Annex II*	Annex IV**
T6020	Electro Command	71.0 dB(A)	77.0 dB(A)	81.0 dB(A)
T6040	Electro Command	71.0 dB(A)	77.0 dB(A)	81.0 dB(A)
T6060	Electro Command	71.0 dB(A)	77.0 dB(A)	81.0 dB(A)
T6030	Electro Command	71.0 dB(A)	78.0 dB(A)	84.0 dB(A)
T6050	Electro Command	71.0 dB(A)	78.0 dB(A)	84.0 dB(A)
T6070	Electro Command	71.0 dB(A)	78.0 dB(A)	84.0 dB(A)

Tractors with Cabin and Fixed Windscreen without Air Cleaner Extraction System

	Transmission	Noise level at operators ear		Drive by noise level
		Closed ⁽¹⁾ Annex II*	Open ⁽²⁾ Annex II*	Annex IV**
T6020	Electro Command	71.0 dB(A)	77.0 dB(A)	80.0 dB(A)
T6040	Electro Command	71.0 dB(A)	77.0 dB(A)	80.0 dB(A)
T6060	Electro Command	71.0 dB(A)	77.0 dB(A)	80.0 dB(A)
T6030	Electro Command	71.0 dB(A)	79.0 dB(A)	84.0 dB(A)
T6050	Electro Command	71.0 dB(A)	79.0 dB(A)	84.0 dB(A)
T6070	Electro Command	71.0 dB(A)	79.0 dB(A)	84.0 dB(A)

* Test results are in accordance with directive 77/311/EEC Annex II.

Maximum noise level at the operators ear with:

- 1) all cab windows and doors closed, tractor off load
- 2) rear window and roof hatch open, tractor off load.

** Test results are in accordance with directive 74/151/EEC Annex VI.

This as a preview PDF file from best-manuals.com



Download full PDF manual at best-manuals.com