

1021F
1121F
Tier 2
Wheel Loader

SERVICE MANUAL

Part number 47392461
1st edition English
July 2012



Contents

INTRODUCTION

Engine.....	10
Engine and crankcase.....	10.001
Air cleaners and lines.....	10.202
Engine lubrication system	10.304
Aftercooler.....	10.310
Fan and drive.....	10.414
Transmission.....	21
Powershift transmission	21.113
Powershift transmission external controls	21.135
Gearbox internal components	21.145
Powershift transmission internal components.....	21.155
Four-Wheel Drive (4WD) system	23
Drive shaft.....	23.314
Front axle system	25
Powered front axle	25.100
Front bevel gear set and differential.....	25.102
Final drive hub, steering knuckles, and shafts	25.108
Rear axle system.....	27
Powered rear axle	27.100
Brakes and controls	33
Parking brake / Parking lock.....	33.110
Hydraulic service brakes	33.202
Hydraulic systems.....	35
Hydraulic systems	35.000
Variable displacement pump	35.106
Reservoir, cooler, and filters.....	35.300

Pilot system.....	35.357
Main control valve	35.359
Auxiliary hydraulic valves and lines	35.525
Front loader arm hydraulic system	35.701
Steering.....	41
Auxiliary steering	41.910
Wheels.....	44
Front wheels.....	44.511
Cab climate control	50
Air conditioning	50.200
Electrical systems	55
Electrical system	55.000
Fuel tank system	55.011
Engine cooling system	55.012
Engine control system.....	55.015
Transmission control system	55.024
Service brake electrical system	55.030
Parking brake electrical system	55.031
Hydraulic system control	55.036
Steering control system	55.047
Heating, Ventilation, and Air-Conditioning (HVAC) control system.....	55.050
Cab Heating, Ventilation, and Air-Conditioning (HVAC) controls.....	55.051
Harnesses and connectors	55.100
Engine starting system	55.201
Cold start aid	55.202
Alternator	55.301
Battery	55.302
External lighting	55.404
External lighting switches and relays.....	55.405

Warning indicators, alarms, and instruments.....	55.408
Loader arm and bucket control system.....	55.415
Cab/Platform harnesses and connectors.....	55.510
Cab controls	55.512
Cab lighting	55.514
Wiper/Washer system	55.518
Cab brake controls	55.519
Cab controls (Lift arm, Boom, Dipper, Bucket)	55.524
FAULT CODES	55.DTC
Platform, cab, bodywork, and decals	90
Machine shields and guards.....	90.105
Protections and footboards.....	90.118
Pneumatically-adjusted operator seat.....	90.124
Cab	90.150



INTRODUCTION

Contents

INTRODUCTION

Torque	3
1021F INT, 1121F INT	
Capacities	6
1021F INT, 1121F INT	
Consumables - Biodiesel Fuel	12
Hydraulic contamination	13

Torque

1021F INT, 1121F INT

Alternator

Alternator pulley retaining nut	95 - 109 N·m (70 - 80 lb ft)
Battery terminal nut	6 - 8 N·m (55 - 72 lb in)
Indicator light terminal nut	2 - 3 N·m (16 - 24 lb in)

Axle

Planetary carrier lock screws	200 N·m (148 lb ft)
Brake spring retainer cover	34 N·m (25 lb ft)
Axle wheel end screw plug	50 N·m (37 lb ft)
Nut Securing Brake Tube to Connector	100 N·m (74 lb ft)
Brake Tube Fitting to Wheel End Fitting	36 N·m (27 lb ft)
Axle housing bolts	560 N·m (413 lb ft)
Input flange slotted nut	1200 N·m (885 lb ft)
Differential releasing housing cover bolts	185 N·m (136 lb ft)
Differential housing cover bolts	400 N·m (295 lb ft)
Wheel mounting bolts	644 - 719 N·m (475 - 530 lb ft)
Axle breather valve	4 - 6 N·m (35 - 53 lb in)
Front axle mounting bolts	1519 - 1708 N·m (1120 - 1260 lb ft)
Rear trunnion cover bolts	103 - 115 N·m (76 - 85 lb ft)
Rear trunnion spacer bolts	285 - 319 N·m (210 - 235 lb ft)
Trunnion casting mounting	651 - 732 N·m (480 - 540 lb ft)

Chassis

Cab and canopy mounting bolts	773 - 854 N·m (570 - 630 lb ft)
Counterweight mounting bolts	1125 - 1261 N·m (830 - 930 lb ft)
Lower step support bolts	27 - 31 N·m (20 - 23 lb ft)
Battery hold down bolts	651 - 732 N·m (480 - 540 lb ft)

Cooling

Cooling frame mounting	271 - 298 N·m (200 - 220 lb ft)
Fan mounting nut	109 - 122 N·m (80 - 90 lb ft)

Drivetrain

Flex plate to flywheel bolts	33 - 41 N·m (24 - 30 lb ft)
Carrier bearing bolt	149 - 163 N·m (110 - 120 lb ft)
Drive line mounting bolts	136 - 149 N·m (100 - 110 lb ft)
Transmission sight gauge mounting bolts	3 - 5 N·m (24 - 48 lb in)
Transmission shock mount nuts	929 - 1044 N·m (685 - 770 lb ft)
Transmission-to-bracket bolts	1125 - 1275 N·m (830 - 940 lb ft)
Transmission-to-flywheel housing bolts	54 - 60 N·m (40 - 44 lb ft)
Transmission fill tube bolts	17 - 33 N·m (151 - 292 lb in)
Banjo tube bolt	160 N·m (118 lb ft)
Bypass valve hose clamps	10 - 11 N·m (90 - 100 lb in)

Engine

Air intake hose clamps	4 - 5 N·m (35 - 44 lb in)
Aspirator hose clamps	3 N·m (30 lb in)
Muffler flex tube clamp	18 - 22 N·m (13 - 16 lb ft)
Muffler clamp at turbo	5 - 6 N·m (44 - 53 lb in)
Starter motor mounting bolts	41 - 48 N·m (30 - 35 lb ft)
Engine support bracket-to-rear chassis bolts	386 - 434 N·m (285 - 320 lb ft)
Engine shock mount nuts	397 - 447 N·m (293 - 330 lb ft)

Fuel tank

Tighten the fuel sender bolts in the sequence as shown in the image (2) to a torque of **6 - 8 N·m (53 - 71 lb in)**.

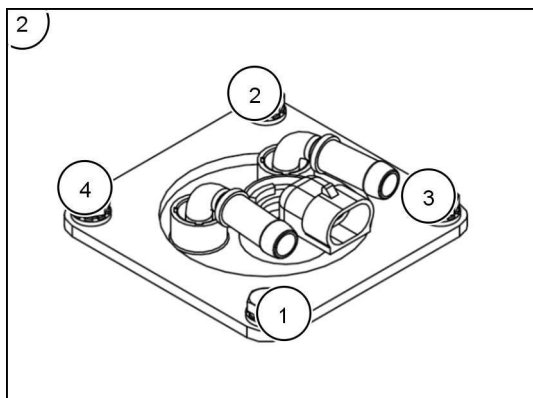

RCPH11WHL117AAR 1

Fuel sender mounting bolts	6 - 8 N·m (53 - 71 lb in)
Fuel tank skid plate bolts (bolts and nuts are to be torqued only one time. Replace as necessary)	122 - 164 N·m (90 - 121 lb ft)
Fuel tank mounting bolts (bolts and nuts are to be torqued only one time. Replace as necessary)	301 - 407 N·m (222 - 300 lb ft)

Hydraulics

Priority valve mounting bolts	85 - 102 N·m (63 - 75 lb ft)
Main hydraulic pump elbow	85 - 102 N·m (63 - 75 lb ft)
Hydraulic tank sight gauge mounting	3 - 6 N·m (27 - 53 lb in)
Surge tank hose clamp mounting	48 N·m (35 lb ft)
Brake pump mounting bolts	149 - 170 N·m (110 - 125 lb ft)
Hydraulic oil tank suction hose clamps	10 - 11 N·m (90 - 100 lb in)
Split, half clamp flange bolts (hydraulic tank-to-pumps and priority valve-to-pump)	73 - 90 N·m (54 - 67 lb ft)
Split, half clamp flange bolts (priority valve-to-loader valve)	198 - 242 N·m (146 - 179 lb ft)
Pump mounting bolts	149 - 170 N·m (110 - 125 lb ft)

Wheels

Tighten the wheel nuts in two stages. First, tighten the wheel nuts in the sequence as shown in the image (1) to a torque of **278 N·m (205 lb ft)**. Second, tighten the wheel nuts in the sequence as shown in the image (1) to a torque of **640 - 720 N·m (472 - 531 lb ft)**.

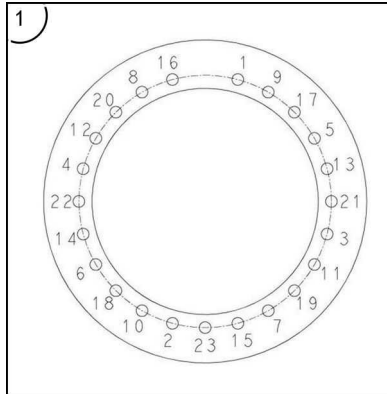

RCPH11WHL202AAH 2

Wheel nuts

First stage: **278 N·m (205 lb ft)**. Second stage: **640 - 720 N·m (472 - 531 lb ft)**

Capacities

1021F INT, 1121F INT

1021F Capacities and specifications

Engine	
Type of oil	CASE AKCELA ENGINE OIL 15W-40
Capacity (with filter change)	28.5 l (30.1 US qt)
Cooling system	
System capacity	56.8 l (60.0 US qt)
Fuel system	
System capacity	473.0 l (125.0 US gal)
Hydraulic system	
Type of fluid	CASE AKCELA HY-TRAN® ULTRA™ HYDRAULIC TRANSMISSION OIL
Total system capacity	250.0 l (66.0 US gal)
Reservoir capacity	134.0 l (35.4 US gal)
Transmission	
Type of oil	CASE AKCELA NEXPLORE™ FLUID
Service capacity - with filter change	45.4 l (48.0 US qt)
Axles	
Type of oil	CASE AKCELA NEXPLORE™ FLUID
Front axle	42.0 l (44.4 US qt)
Rear axle	42.0 l (44.4 US qt)
Front axle with axle cooler	45.7 l (48.3 US qt)
Rear axle with axle cooler	45.7 l (48.3 US qt)
Heavy duty front axle	62.0 l (65.5 US qt)
Heavy duty front axle with cooler	65.7 l (69.4 US qt)
Grease fittings, as required	CASE AKCELA MOLY GREASE

* Machines are shipped from the factory with break-in oil.

1121F Capacities and specifications

Engine	
Type of oil	CASE AKCELA ENGINE OIL 15W-40
Capacity (with filter change)	28.5 l (30.1 US qt)
Cooling system	
System capacity	56.8 l (60.0 US qt)
Fuel system	
System capacity	473.0 l (125.0 US gal)
Hydraulic system	
Type of fluid	CASE AKCELA HY-TRAN® ULTRA™ HYDRAULIC TRANSMISSION OIL
Total system capacity	250.0 l (66.0 US gal)
Reservoir capacity	134.0 l (35.4 US gal)
Transmission	
Type of oil	CASE AKCELA NEXPLORE™ FLUID
Service capacity - with filter change	45.4 l (48.0 US qt)
Axles	
Type of oil	CASE AKCELA NEXPLORE™ FLUID
Front axle	64.0 l (67.6 US qt)
Rear axle	64.0 l (67.6 US qt)
Front axle with axle cooler	67.7 l (71.5 US qt)
Rear axle with axle cooler	67.7 l (71.5 US qt)
Front axle with differential lock	62.0 l (65.5 US qt)
Front axle with differential lock and axle cooler	65.7 l (69.4 US qt)
Grease fittings, as required	CASE AKCELA MOLY GREASE

* Machines are shipped from the factory with break-in oil.

Engine oil viscosity/Temperature ranges

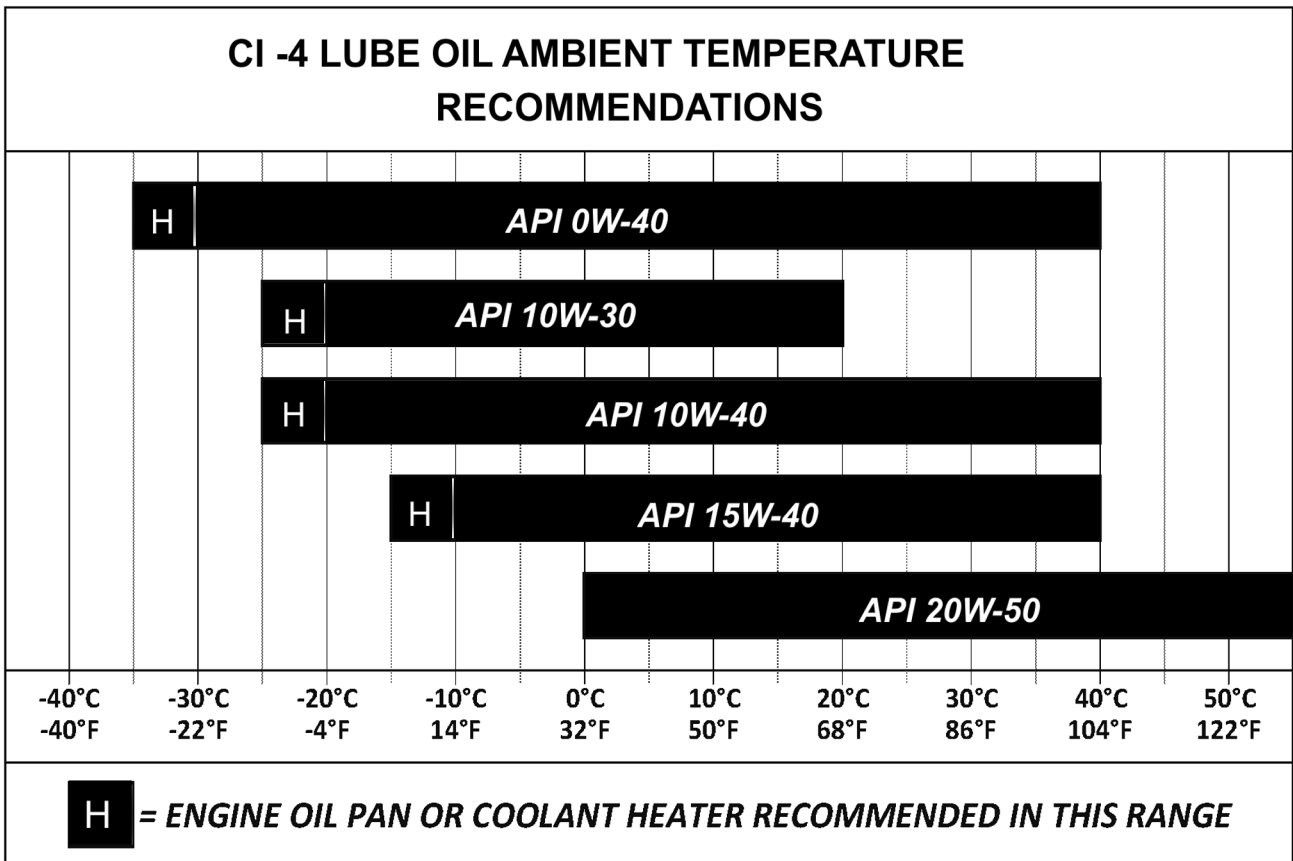

RCPH11WHL023FAH 1

NOTE: Use of an engine oil pan heater or an engine coolant heater may be required when operating temperatures are in Winter or Arctic conditions.

Transmission oil viscosity/Temperature ranges

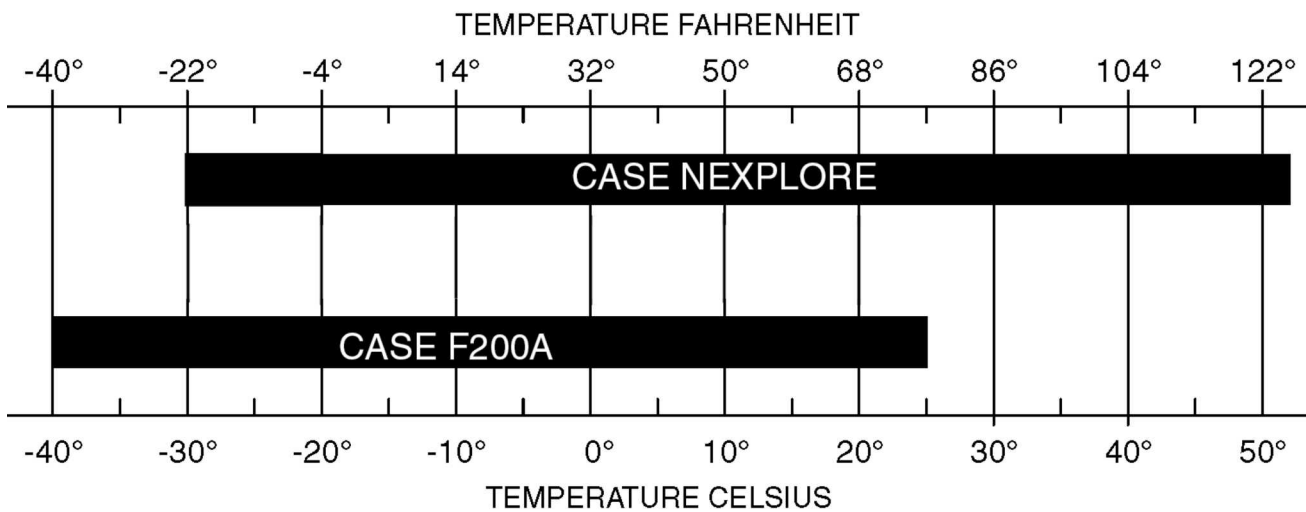

RCPH10WHL453BAH 2

Hydraulic/Brake system - temperature range

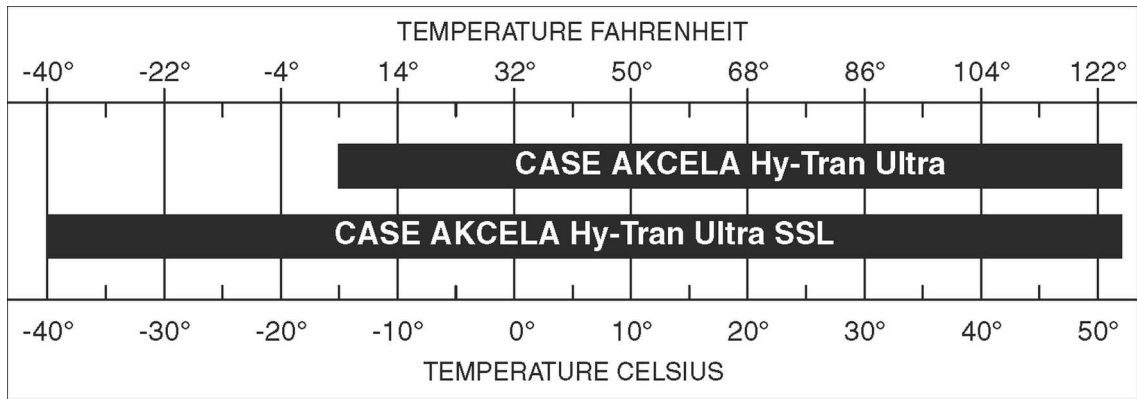

RCPH10WHL006EAL 3

Coolant solution

Put only ethylene-glycol coolant solution in the cooling system. Use good quality ethylene-glycol that has a high boiling point with no additives to prevent leakage. Do not use non-approved anti-rust additives. Anti-rust additives and ethylene-glycol can mix and work against each other, reducing anti-corrosion protection, forming deposits in the cooling system, and causing damage to the cooling system and radiator. Contact your dealer who can supply you with the suitable coolant solution.

Anti-freeze/Anti-corrosion

Use anti-freeze in all seasons to protect the cooling system from corrosion and risk of freezing. For areas where the ambient temperature is over **-36 °C (-32.8 °F)** use a blend of 50% ethylene-glycol based anti-freeze.

For areas where the temperature is below **-36 °C (-32.8 °F)**- it is advisable to use a blend of 40% water and 60% anti-freeze.

Fuel

Use diesel fuel suitable for the ambient temperature conditions (ASTM-D-975).

Use fuel which is to ASTM (American Society for Testing and Materials) D975 standard.

Use grade No. 2 fuel. The use of other types of fuel can result in a loss of power of the engine and may cause high fuel consumption.

In very low ambient temperatures, use a mixture of fuels No. 1 and No. 2 as necessary. Consult your fuel supplier for appropriate fuel supply.

If the temperature falls below the fuel cloud point (point at which wax begins to form) the wax crystals will cause power loss or will prevent the engine from starting.

In cold weather, fill the fuel tank at the end of the day's work in order to prevent the formation of condensation.

Fuel storage

Prolonged storage of fuel can lead to the accumulation of impurities and condensation in the fuel. Engine trouble can often be traced to the presence of water in the fuel.

The storage tank must be placed outside and the temperature of the fuel should be kept as low as possible. Drain off water and impurities regularly.

Hydraulic fluid

Case Akcela Hy-Tran Ultra hydraulic fluid is specifically designed for high pressure applications and for Case hydraulic systems. Your Case Dealer can provide hydraulic fluid to fulfill different climate/temperature conditions. Refer to the charts at the beginning of this section.

Transmission component oil

Extreme pressure oil should be used for enclosed transmission components. Choose an oil that is manufactured for your climate/temperature conditions such as Case Nexplore or CNH F200A. See charts at the beginning of this section.

Grease

The type of grease to use depends on ambient temperature such as: Case Akcela Molydisulfide Grease

Environment

Before you service this machine and dispose of oil, fluids, and lubricants, obey environmental regulations. Do not drain oil or fluids on to the ground or into containers that leak. Check with your local environmental, recycling center or your dealer for correct disposal information.

Engine oil

Case Akcela engine oil is recommended for your engine. This oil insures correct lubrication of your engine in all working conditions. See charts at the beginning of this section to choose the correct oil for climate/temperatures.

If Case Akcela engine oil cannot be obtained, use only oil of the API SERVICE CI-4 category.

NOTE: Do not put any Performance Additive or other additive in the sump. Oil change intervals shown in this manual are based on tests carried out utilizing Case lubricants.



RCPH10WHL012AAD 4

Consumables - Biodiesel Fuel

Fatty Acid Methyl Ester Biodiesel (Biodiesel Fuel) consists of a family of fuels derived from vegetable oils treated with methyl esters.

NOTICE: *Biodiesel fuel blends are approved for your engine only if they comply with Specification Standards EN 14214 or ASTM D6751.*

NOTICE: *Verify with your local dealer which blends are approved for your engine. Use of biodiesel fuel that does not comply with the Standards EN14214 or ASTM D6751 could lead to severe damage to engine and fuel system. Use of non-approved biodiesel fuels may void warranty coverage.*

Biodiesel Fuel Usage Conditions

Biodiesel fuels must be purchased from a trusted supplier that understands the product and maintains good fuel quality. Biodiesel fuels must be pre-blended by the supplier. Mixing biodiesel fuels on site can result in an incorrect mixture which can damage engine and fuel system.

Engine performance is effected by the use of biodiesel fuels. There may be up to 12 percent reduction in power or torque depending on the blend used.

NOTICE: *DO NOT modify the engine and/or fuel injection pump settings to recover reduced performance.*

The reduced power must be accepted if using any biodiesel fuel blends.

NOTICE: *The use of high biodiesel fuel blends is not recommended in cold weather conditions.*

Using biodiesel fuels may require changing engine oil, engine oil filters, and fuel filter elements more frequently. Biodiesel fuels can remove rust and other particles that adhere to the inside of the fuel tank. These particles are trapped by vehicle filters and may cause shortened filter life or filter blockages. Blockages are more common in cold weather conditions. Consult your dealer for information on cold weather operation and proper maintenance intervals when using any biodiesel fuel blend.

Biodiesel fuel may degrade natural rubber gaskets and hoses, as it is more solvent than petro-diesel. Frequently inspect hoses and other engine components when using biodiesel fuel.

DO NOT allow water to collect in the fuel or storage tanks. Biodiesel fuel attracts moisture from the atmosphere. Keep fuel tanks and storage tanks as full as possible to limit the amount of air and water vapors. It may be necessary to drain machine fuel filter more frequently. Potential oxidation and stability could create a problem with fuel stored in the machine.

Biodiesel Storage

NOTICE: *DO NOT store machines for more than three months with biodiesel blends in the fuel system. DO NOT store biodiesel fuel in on-site storage tanks for more than three months.*

If long periods of storage are required, run the machine for 20 hours using regular diesel fuel to flush the biodiesel fuel from the engine fuel system.

NOTICE: *Biodiesel fuels must not be stored in on-site storage tanks for more than 3 months. Any spillage of biodiesel fuels must be cleaned up immediately before it can cause damage to the environment or the paint finish of the machine. Before using biodiesel fuel blends, you should consult with your dealer to receive full information about the approved blend for your machine and any detailed conditions of its usage. Failure to follow the requirements and conditions of biodiesel fuel usage will void your machine's warranty.*

NOTE: *B7 is the highest biodiesel (7% blend) that should be used in this machine.*

Hydraulic contamination

Contamination in the hydraulic system is a major cause of the malfunction of hydraulic components. Contamination is any foreign material in the hydraulic oil. Contamination can enter the hydraulic system in several ways.

- (A) When you drain the oil or disconnect any line.
- (B) When you disassemble a component.
- (C) From normal wear of the hydraulic components.
- (D) From damaged or worn seals.
- (E) From a damaged component in the hydraulic system.

All hydraulic systems operate with some contamination. The design of the components in this hydraulic system permits efficient operation with a small amount of contamination. An increase in this amount of contamination can cause problems in the hydraulic system. The following list includes some of these problems.

- (A) Cylinder rod seals leak.
- (B) Control valve spools do not return to neutral.
- (C) Movement of control valve spools is difficult.
- (D) Hydraulic oil becomes too hot.
- (E) Pump gears, housing, and other parts wear rapidly.
- (F) Relief valves or check valves held open by dirt.
- (G) Quick failure of components that have been repaired.
- (H) Cycle times are slow; machine does not have enough power.

If your machine has any of these problems, check the hydraulic oil for contamination. There are two types of contamination, microscopic and visible.

Microscopic contamination occurs when very fine particles of foreign material are in suspension in the hydraulic oil. These particles are too small to see or feel. Microscopic contamination can be found by identification of the following problems or by testing in a laboratory. Examples of the problems:

- (A) Cylinder rod seal leak.
- (B) Control valve spools do not return to NEUTRAL.
- (C) The hydraulic system has a high operating temperature.

Visible contamination is foreign material that can be found by sight, touch, or odor. Visible contamination can cause a sudden failure of components. Examples of visible contamination:

- (A) Particles of metal or dirt in the oil.
- (B) Air in the oil.
- (C) The oil is dark and thick.
- (D) The oil has an odor of burned oil.
- (E) Water in the oil.

If you find contamination, use a Portable Filter to clean the hydraulic system.

CONSUMABLES INDEX

Consumable	IU	PAGE
CASE Akcela Engine oil 15W-40	Capacities	6
CASE Akcela HY-TRAN® Ultra™ hydraulic transmission oil	Capacities	6
CASE Akcela NEXPLORE™ fluid	Capacities	6
CASE Akcela NEXPLORE™ fluid	Capacities	6
CASE Akcela Moly grease	Capacities	6
CASE Akcela Engine oil 15W-40	Capacities	7
CASE Akcela HY-TRAN® Ultra™ hydraulic transmission oil	Capacities	7
CASE Akcela NEXPLORE™ fluid	Capacities	7
CASE Akcela NEXPLORE™ fluid	Capacities	7
CASE Akcela Moly grease	Capacities	7

CASE

CONSTRUCTION

SERVICE MANUAL

Engine

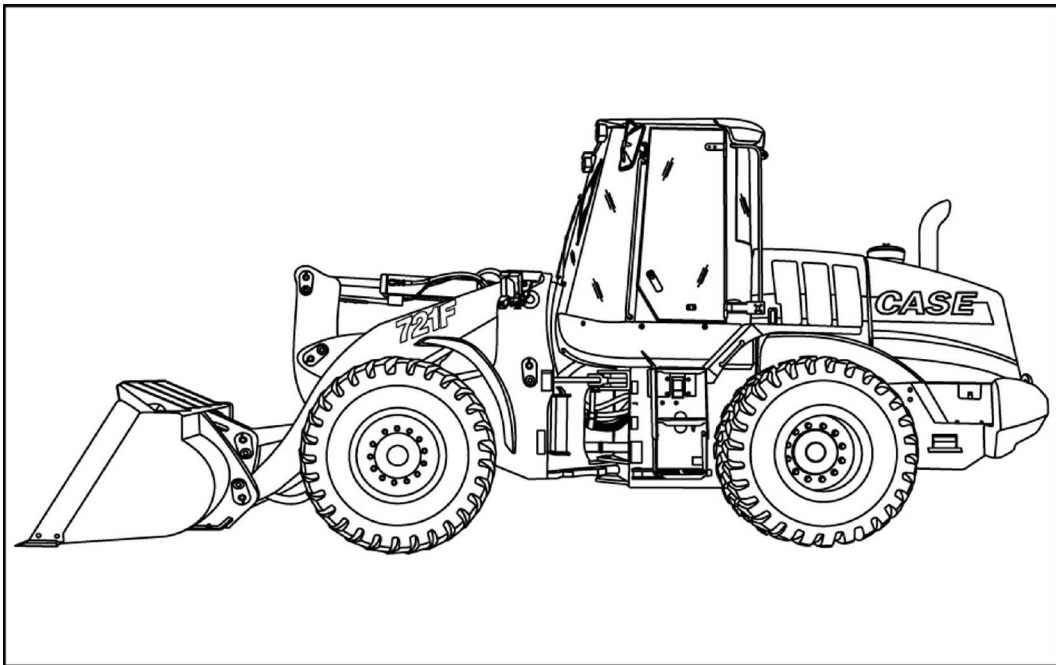

**1021F
1121F**

Contents

Engine - 10

Engine and crankcase.....	10.001
1021F , 1121F	
Air cleaners and lines.....	10.202
1021F , 1121F	
Engine lubrication system	10.304
1021F , 1121F	
Aftercooler.....	10.310
1021F , 1121F	
Fan and drive.....	10.414
1021F , 1121F	

CONSUMABLES INDEX

Consumable	IU	PAGE
DOW 732 RTV Silicone clear	Engine - Install	10.001 / 19



Engine - 10

Engine and crankcase - 001

**1021F
1121F**

Contents

Engine - 10

Engine and crankcase - 001

TECHNICAL DATA

Engine	
Speeds	4

SERVICE

Engine	
Remove	5
1021F INT, 1121F INT	
Install	18
1021F INT, 1121F INT	

CONSUMABLES INDEX

Consumable	IU	PAGE
DOW 732 RTV Silicone clear	Engine - Install	10.001 / 19

Engine - Speeds

1021F \ 1121F

Machine idled (alternate low idle)	570 - 630 rpm
Machine idled (cold weather alternate accelerated low idle)	1170 - 1230 rpm

Engine - Remove

1021F INT, 1121F INT

Prior operation:

Engine hood - Remove (90.105)

NOTE: Put caps on the fittings and plugs in the hoses to prevent foreign material from entering the system when disconnecting fuel lines or hydraulic hoses.

1. Park the machine on a level surface and lower the bucket to the ground. Put the articulation lock **(1)** in the locked position.

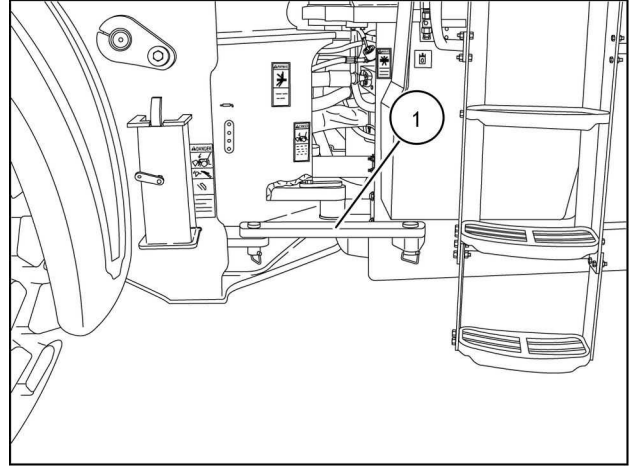

RCPH11WHL039AAH 1

2. Key in the run position, engine off, place the pilot control switch **(1)** in the normal operation position.

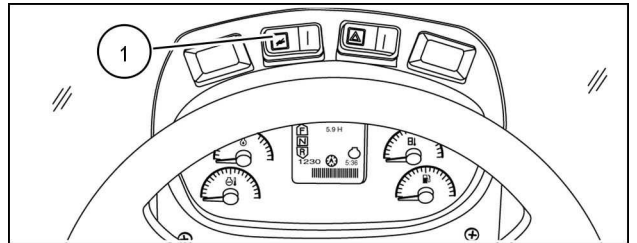

RCPH10WHL982FAH 2

3. Move the loader hydraulic control handle to the raise and lower position in order to release any hydraulic pressure in the lift circuit.
4. Move the loader control handle in and out of the tilt position several times, this will relieve any pressure in the pilot accumulator.
5. Release the pressure in the ride control accumulator with the bleeder valve in the valve load travel stabilizer.
6. Depress the brake pedal several times to discharge brake accumulators.
7. Slowly loosen the filler cap on the hydraulic oil tank to release air pressure.

8. Put the master disconnect switch **(1)** in the off position.

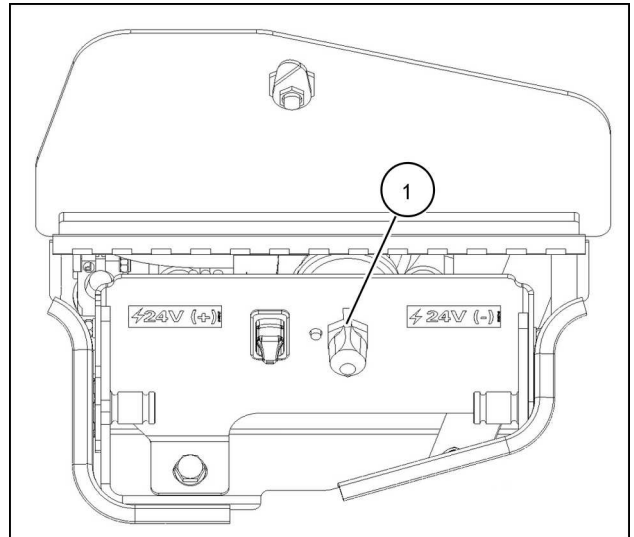

RCPH11WHL094AAH 3

9. Drain the engine radiator coolant.
10. Drain the engine oil.
11. Loosen the hose clamp **(1)** on the air intake hose under the air inlet hood.

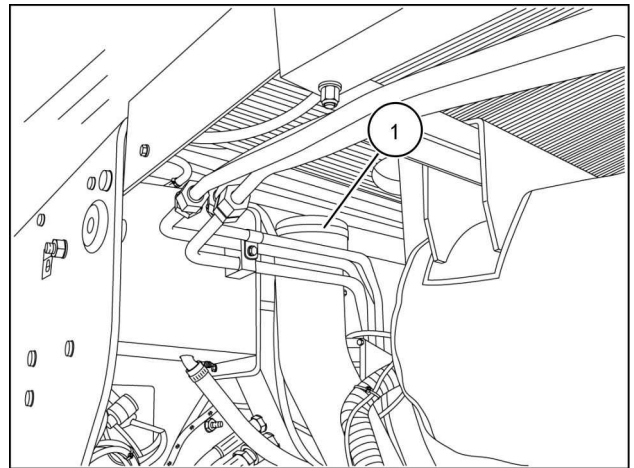

RCPH11WHL053AAR 4

12. Remove the mounting bolts on the exhaust stack hood. Attach lifting equipment to the exhaust stack. Remove the exhaust stack hood **(1)**.

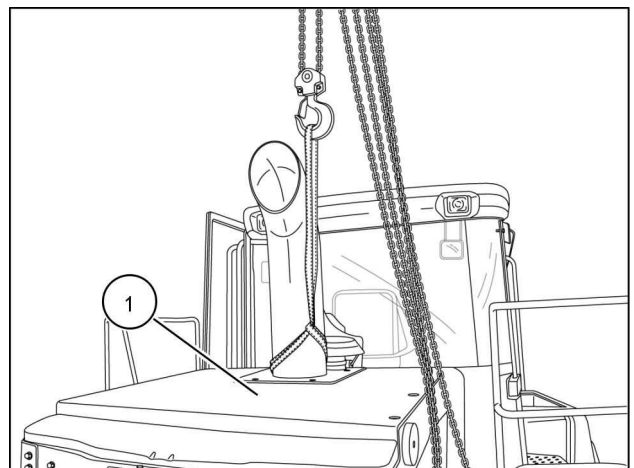

RCPH11WHL010AAR 5

13. Remove the muffler assembly.

14. Disconnect the deaeration tank overflow hose (2).
15. Remove the P-clamps (1) that secure the overflow hose to the wall and brackets. Position the overflow hose away from the engine and engine wall.

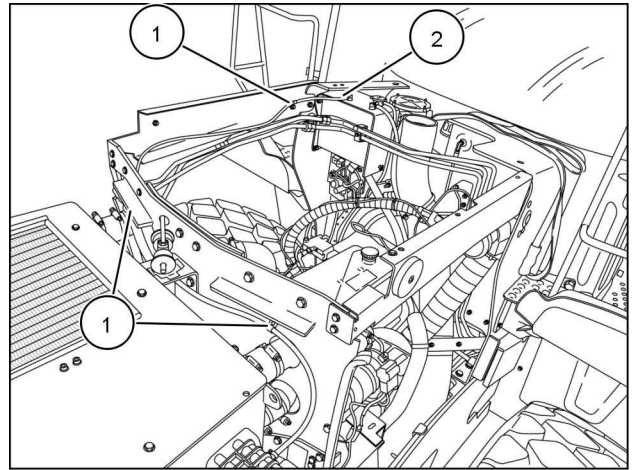

RCPH11WHL012AAR 6

16. Remove the left bracket (1) and right bracket (2).

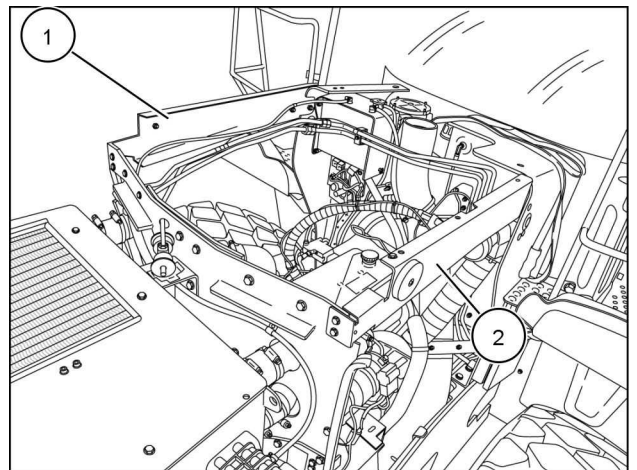

RCPH11WHL012AAR 7

17. Remove the hydraulic oil lines (1).

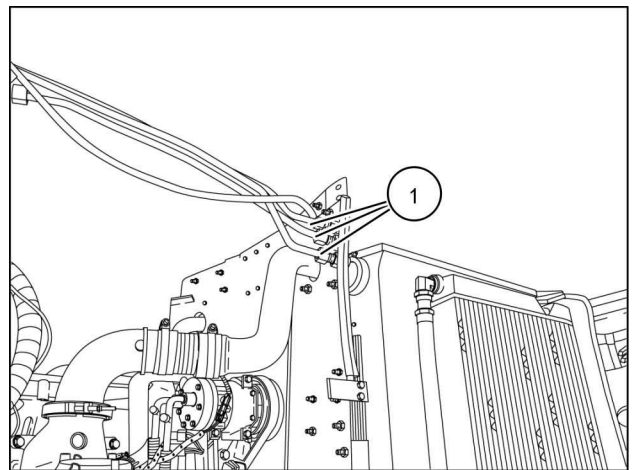

RCPH11WHL013AAR 8

18. Remove the after air cooler tube **(1)** .
19. Remove the bulkheads **(2)**.

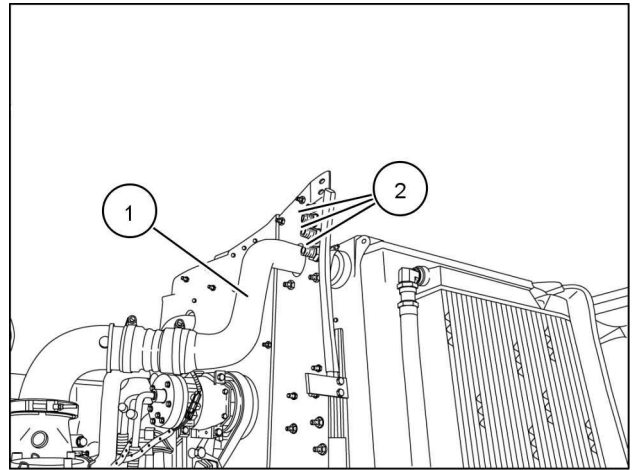

RCPH11WHL014AAR 9

20. Remove the oil dipstick P-clamp **(3)** . Pull the oil dipstick tube **(1)** through the wall.
21. Label and disconnect the hood lift strut electrical connector **(2)**.

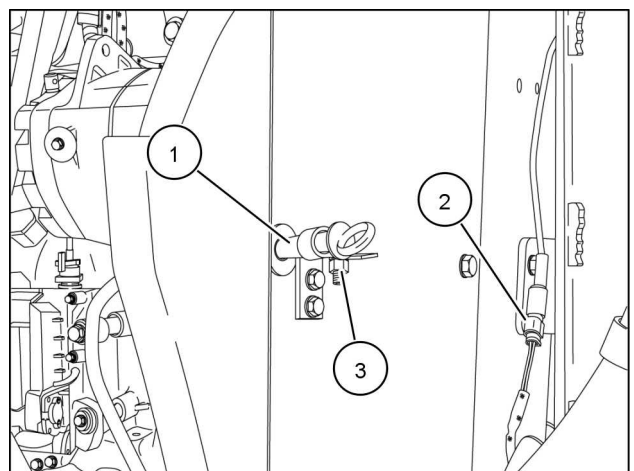

RCPH11WHL015AAR 10

22. Remove the before air cooler tube **(1)**.
23. Remove the upper radiator tube **(2)**.

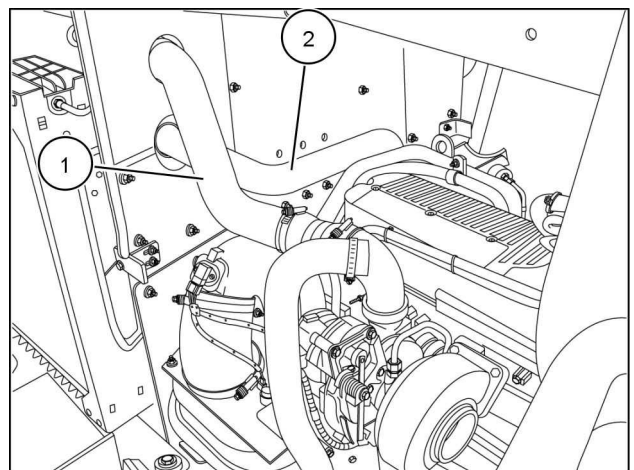

RCPH11WHL016AAR 11

24. Label and disconnect the humidity sensor electrical connector **(1)**.
25. Remove the turbo inlet tube **(2)**.
26. Label and disconnect the air filter restriction sensor electrical connector **(3)**.

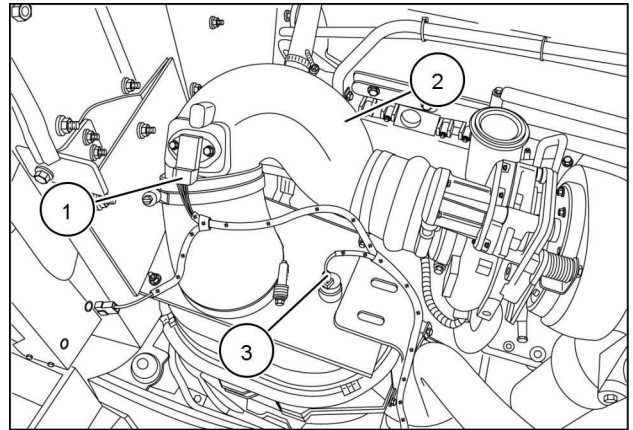

RCPH11WHL017AAR 12

27. Remove the wire harness P-clamp **(1)**.
28. Loosen the hose clamp on the air intake hose **(2)**. Disconnect the air intake hose **(3)**.

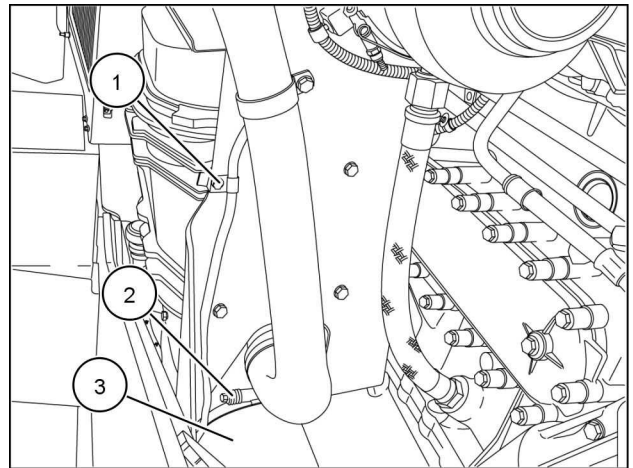

RCPH11WHL018AAR 13

29. Remove the lower, right panel **(1)** on the engine wall.

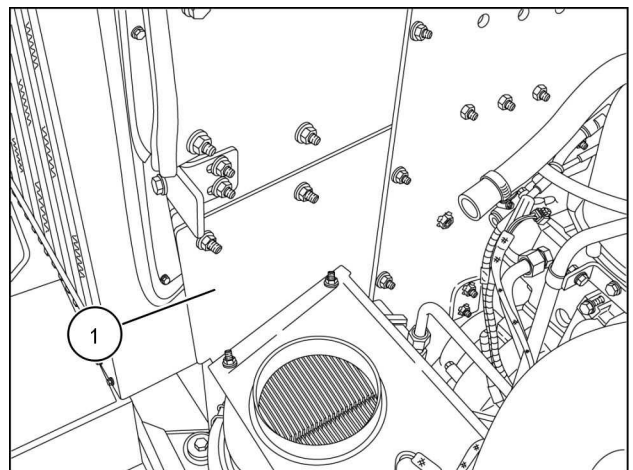

RCPH11WHL020AAR 14

30. Remove the air box assembly.

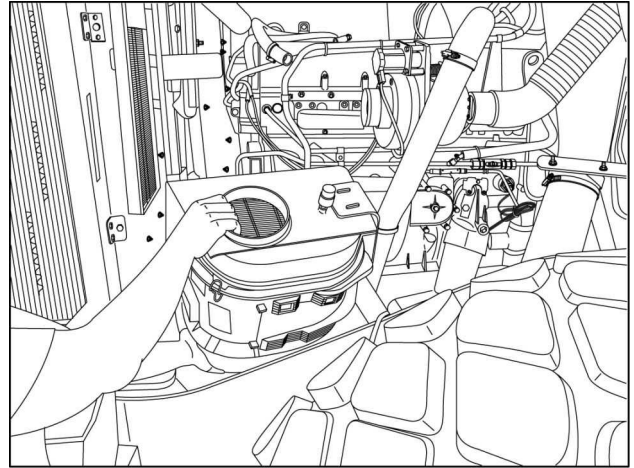

RCPH11WHL019AAR 15

31. Remove the lower radiator tube (1) .

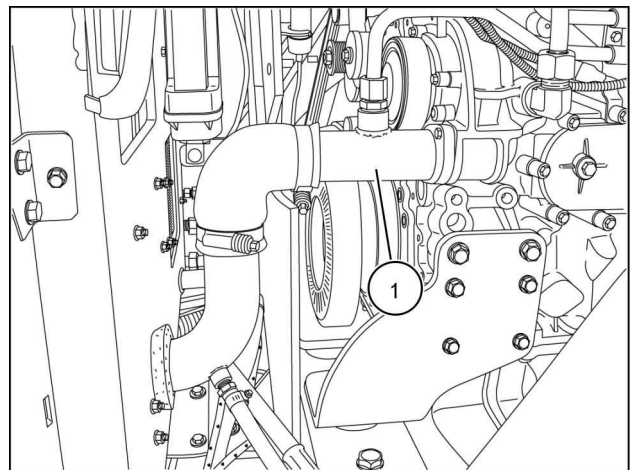

RCPH11WHL021AAR 16

32. Attach lifting equipment to the engine wall. Remove the engine wall's hold-down bolts. Lift and remove the engine wall.

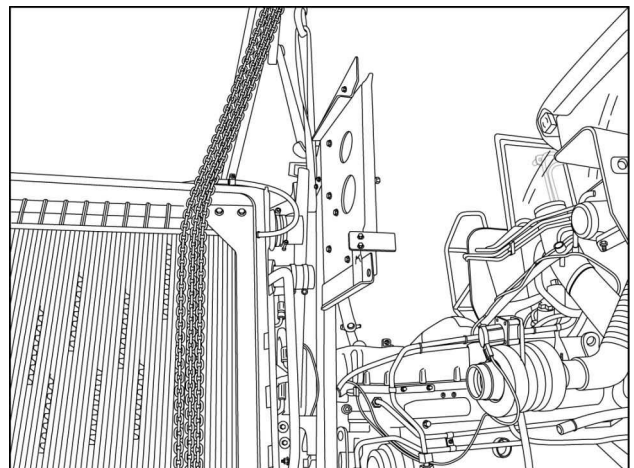

RCPH11WHL039AAR 17

33. Remove the turbo exhaust tube (1).

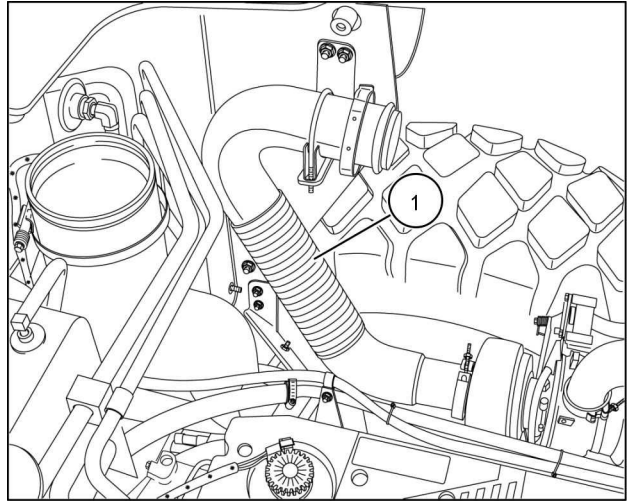

RCPH11WHL022AAR 18

34. Remove two bolts (2), washers (3), and nuts (4). Remove the air intake hose (1).

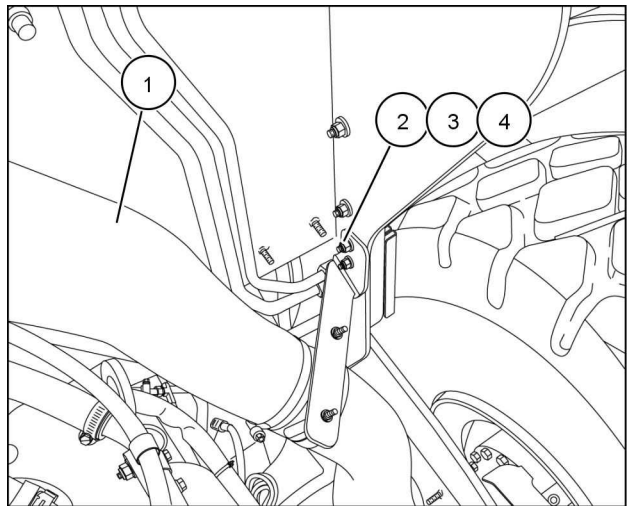

RCPH11WHL023AAR 19

35. Disconnect the inlet and outlet heater core heater hoses (1).

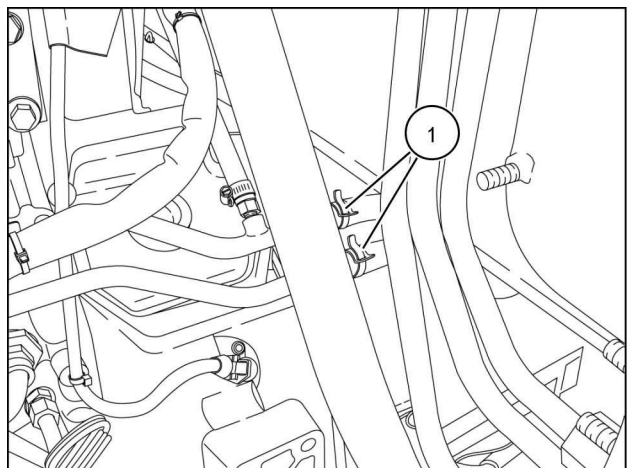

RCPH11WHL038AAR 20

36. Disconnect the starter battery cables **(1)** and starter switch wire **(2)**.

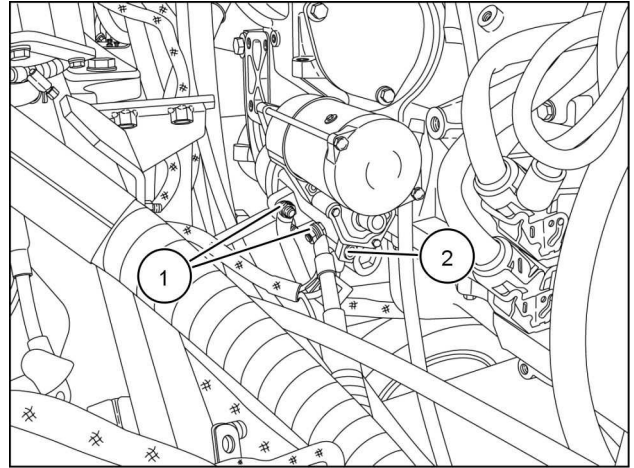

RCPH11WHL049AAR 21

37. Disconnect the following from the crank case ventilation/fuel filter bracket assembly:

- Fuel pump electrical connector
- Water sensor electrical connector
- Ground wire
- Wire harness P-clamp
- Crank case filter inlet hose
- Crank case filter outlet hose
- Crank case filter oil return hose
- Fuel pump inlet tube
- Fuel pump outlet tube

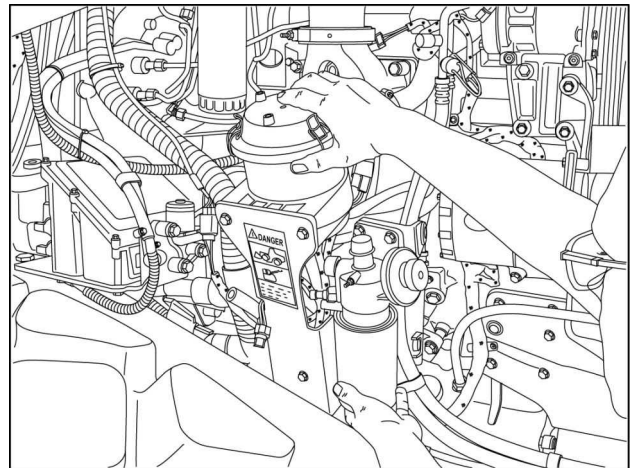

RCPH11WHL040AAR 22

38. Remove the crank case ventilation/fuel filter bracket assembly.

39. Label and disconnect the engine control module electrical connector **(1)**.

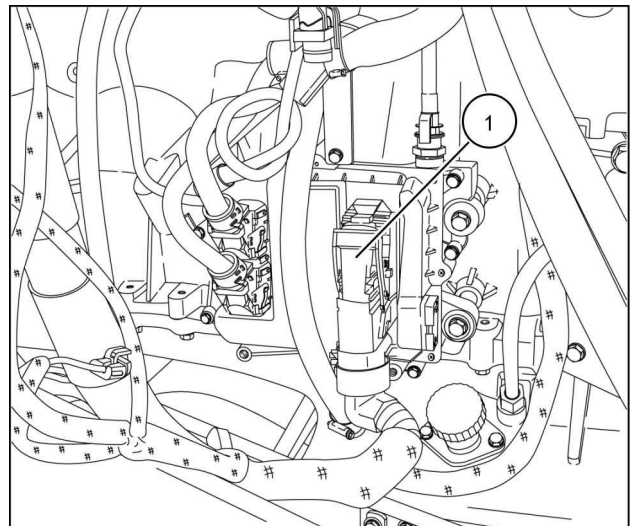

RCPH11WHL041AAR 23

40. Disconnect the fuel return line **(1)**.
41. Disconnect the battery positive wire **(2)** on the air grid heater.

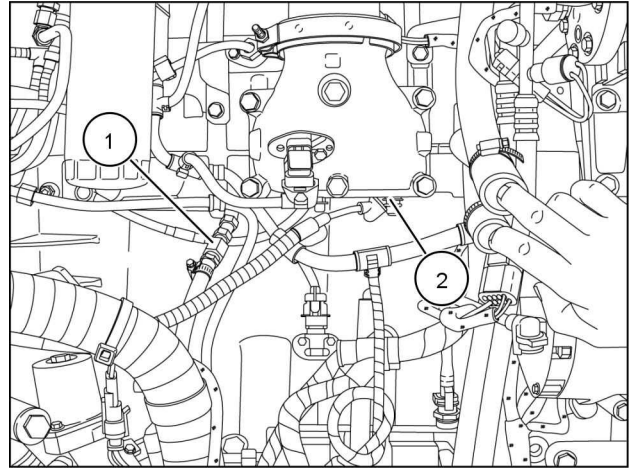

RCPH11WHL042AAR 24

42. Disconnect the engine ground wires **(1)**.
43. Remove the wire harness P-clamp **(2)**.

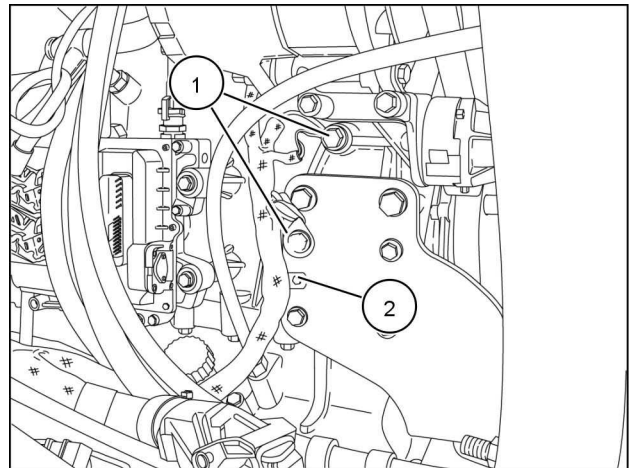

RCPH11WHL043AAR 25

44. Remove the engine serpentine belt **(1)**.

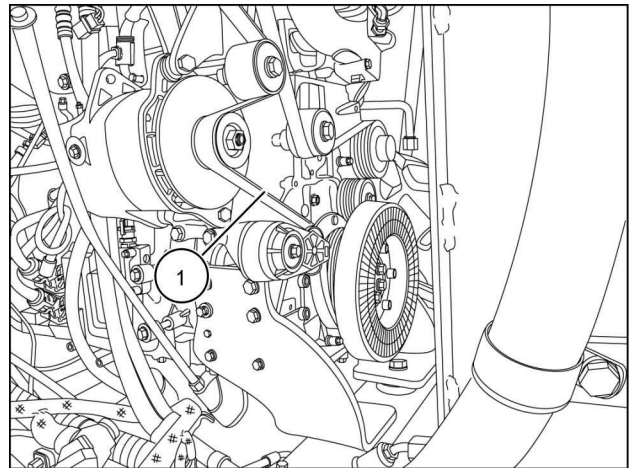

RCPH11WHL051AAR 26

45. Label and disconnect the A/C compressor electrical connector **(1)**.
46. Label and disconnect the A/C pressure switch electrical connector **(4)**.
47. Remove the alternator power wire. **(3)**.
48. Label and disconnect the bulk electrical connector **(5)**.

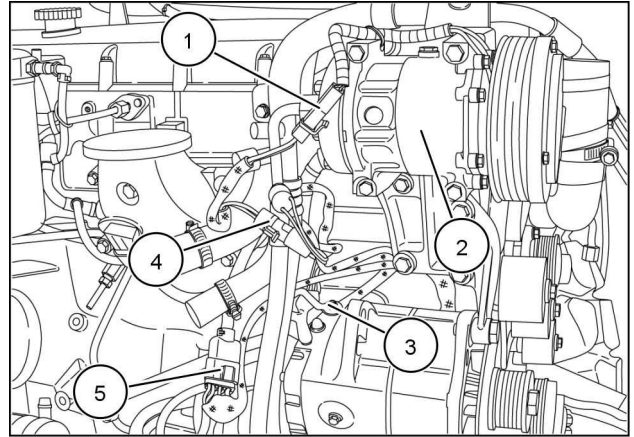

RCPH11WHL045AAR 27

49. Remove the A/C compressor **(2)**. Position the A/C compressor **(2)** away from the engine.
50. Remove the wire harness P-clamps **(1)**.

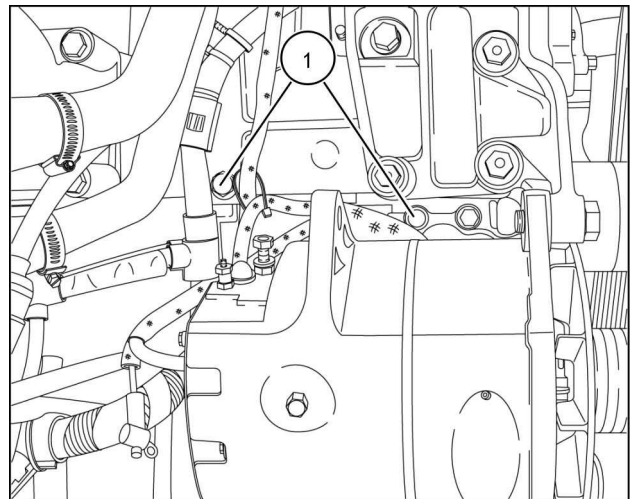

RCPH11WHL046AAR 28

51. Remove the engine oil drain tube **(1)**.

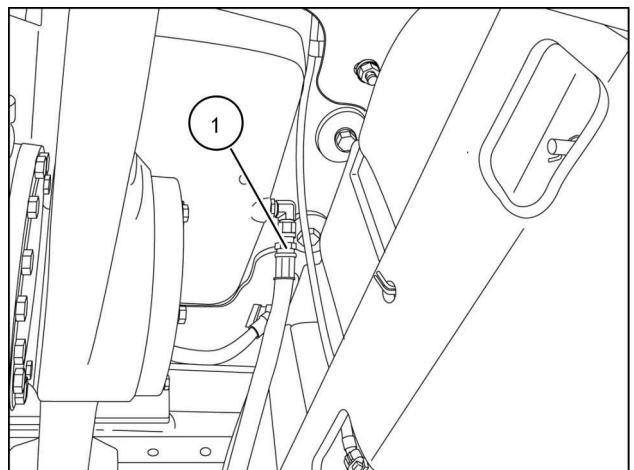

RCPH11WHL047AAR 29

52. Attach lifting equipment to the engine. Support the engine.

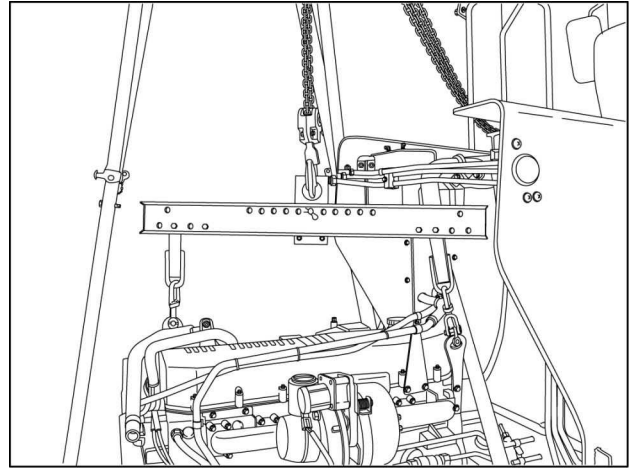

RCPH11WHL048AAR 30

53. Remove the hydraulic oil return tube P-clamp (1). Position the hydraulic oil return tube away from the converter housing cover plate.

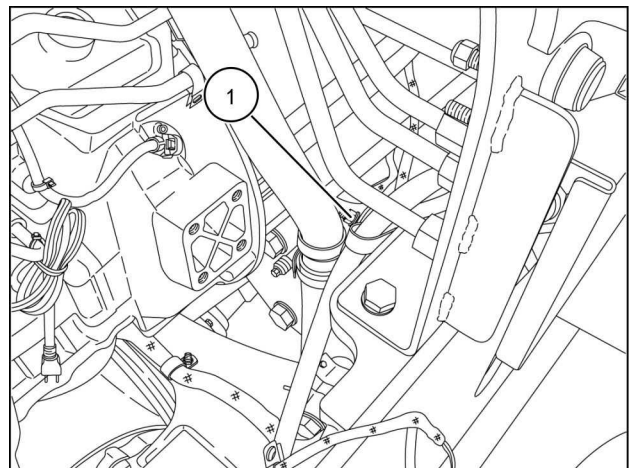

RCPH11WHL050AAR 31

54. For 1021F models, do procedure A. For 1121F models, do procedure B.
- A. Remove the converter housing cover plate (1). See figure 32.
 - B. Remove access cover located above starter, then remove plug behind cover. Carefully remove torque converter bolts through plug hole. Use care to ensure bolts do not fall into engine housing. Supporting figure is currently not available.

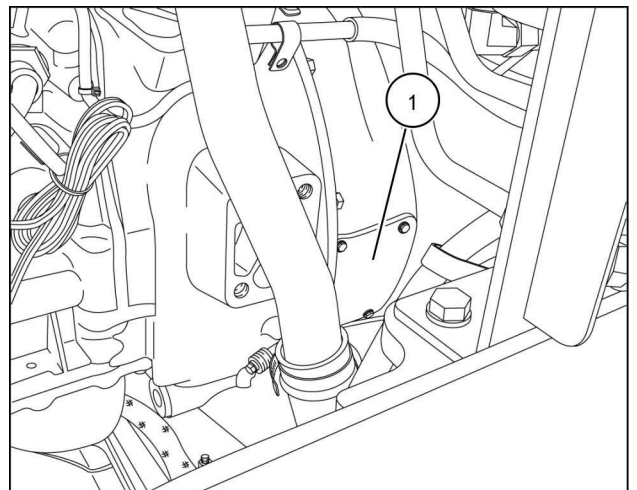

RCPH11WHL034AAR 32

55. Remove the flex plate bolts (1).

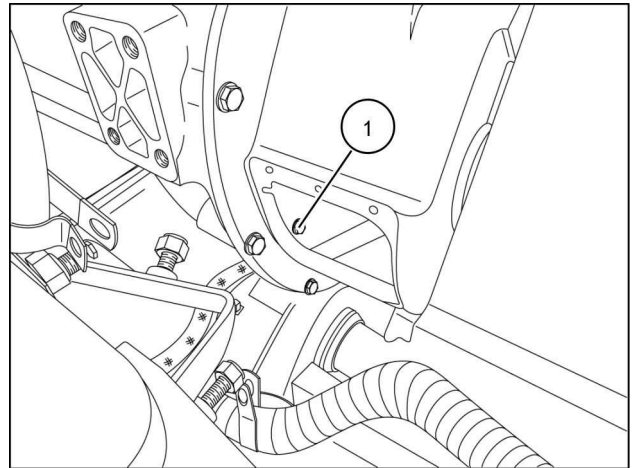

RCPH11WHL035AAR 33

56. Remove the harmonic balancer (1).

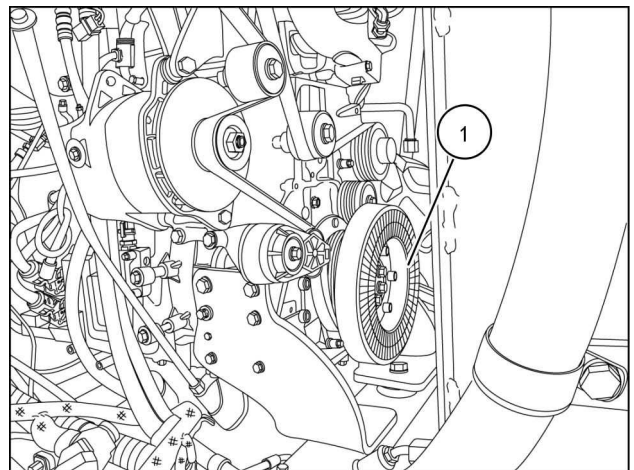

RCPH11WHL051AAR 34

57. Remove the front engine mounts (1) and engine mount plate (2).

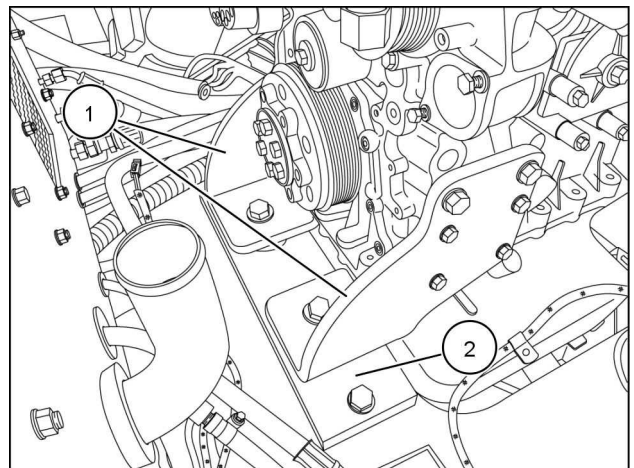

RCPH11WHL052AAR 35

58. Remove the bell housing bolts (1).

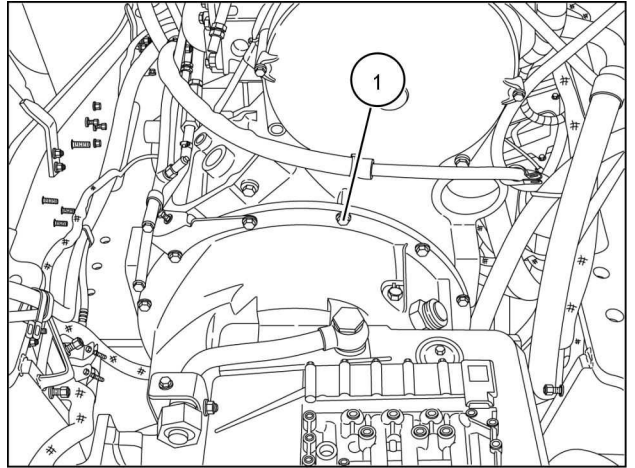

RCPH11WHL036AAR 36

59. Remove the engine.

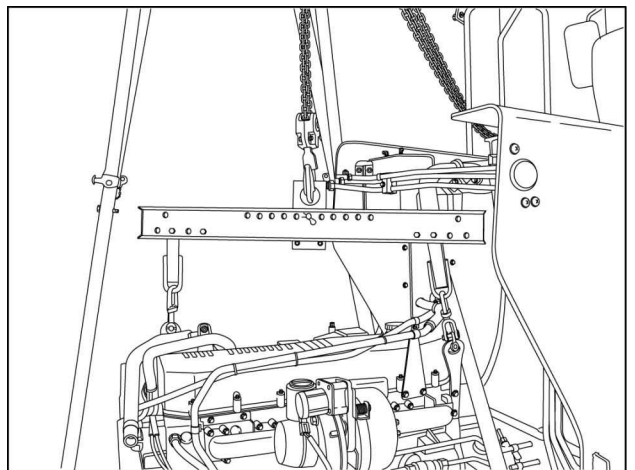

RCPH11WHL048AAR 37

Engine - Install

1021F INT, 1121F INT

1. Carefully lower the engine into the chassis.

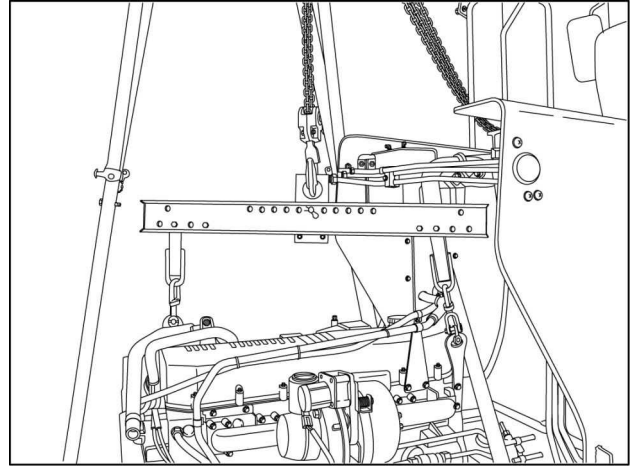

RCPH11WHL048AAR 1

2. Install the bell housing bolts (1). Tighten the bell housing bolts (1) to a torque of **54 - 60 N·m (40 - 44 lb ft)**.

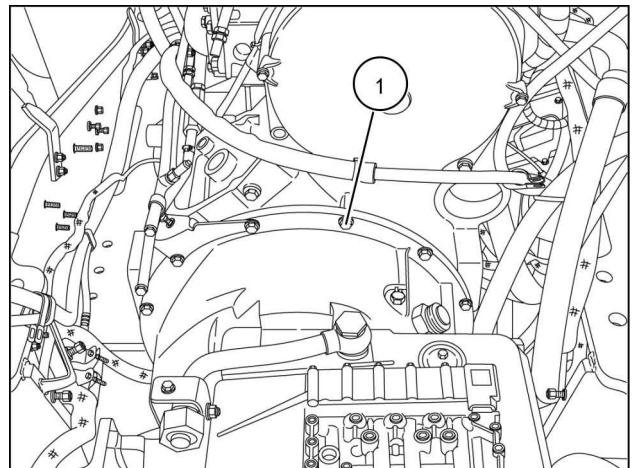

RCPH11WHL036AAR 2

3. Install the engine mount plate (5) and the engine mount brackets (1), but do not tighten the bolts to a torque value.
4. Tighten the engine bracket upper bolts (2) to a torque of **171 - 231 N·m (126 - 170 lb ft)**. Tighten the engine bracket lower bolts (3) to a torque of **69 - 80 N·m (51 - 59 lb ft)**. Tighten the engine mount plate bolts (4) to a torque of **386 - 434 N·m (285 - 320 lb ft)**. Tighten the engine bracket-to-engine mount plate bolts (6) to a torque of **397 - 447 N·m (293 - 330 lb ft)**.

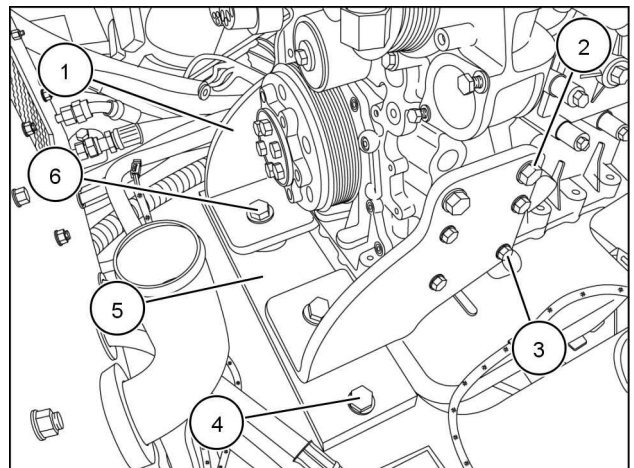

RCPH11WHL052AAR 3

5. Install the harmonic balancer (1). Tighten the harmonic balancer bolts (2) to a torque of **115 N·m (85 lb ft)**.

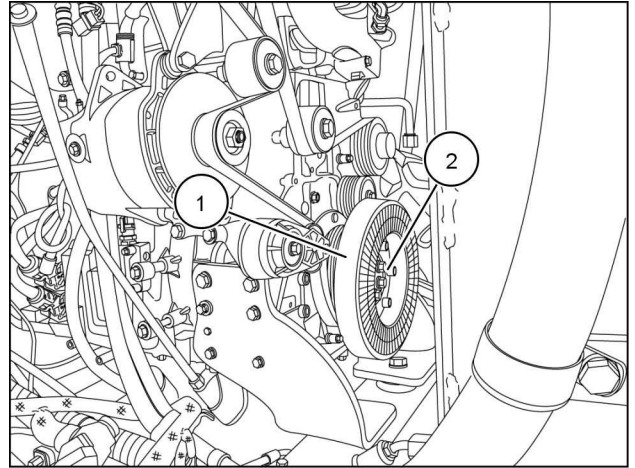

RCPH11WHL051AAR 4

6. Install the flex plate bolts (1). Tighten the flex plate bolts (1) to a torque of **33 - 41 N·m (24 - 30 lb ft)**.

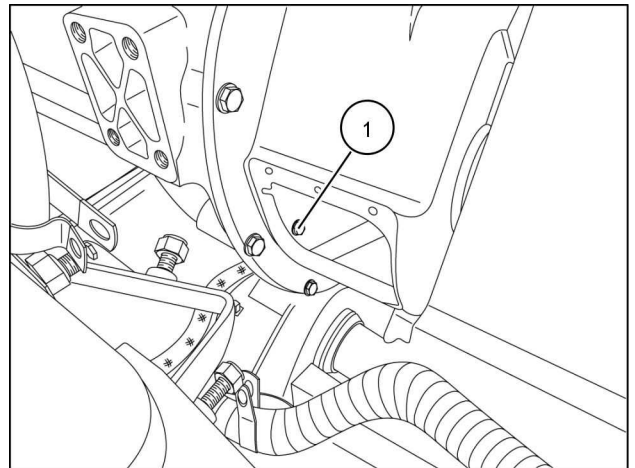

RCPH11WHL035AAR 5

7. For 1021F models, do procedure A. For 1121F models, do procedure B.
- A. Apply **DOW 732 RTV SILICONE CLEAR** to the converter housing cover plate (1). See figure 6.
 - B. Carefully install torque converter bolts through plug hole. Tighten bolts to standard torque. Install plug and housing cover plate. Supporting figure is currently not available.

8. Install the converter housing cover plate (1).

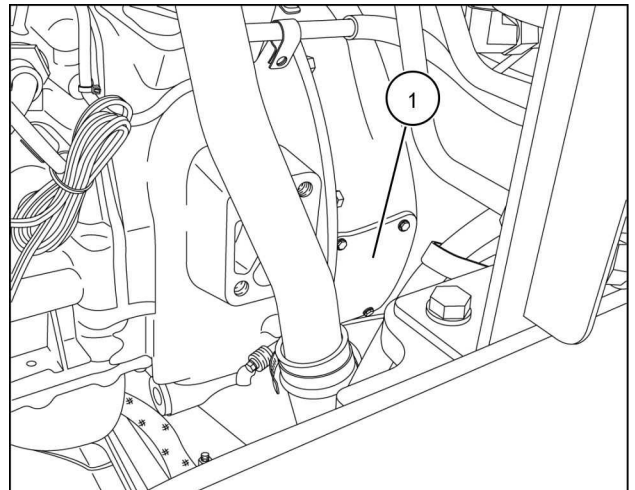

RCPH11WHL034AAR 6

9. Connect the inlet and outlet heater core heater hoses (1).

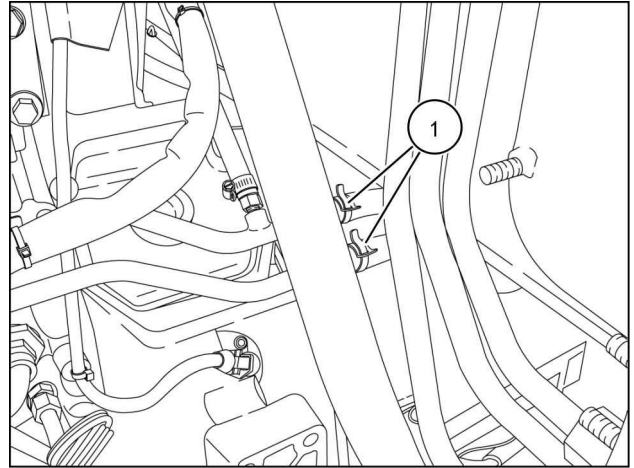

RCPH11WHL038AAR 7

10. Reposition the hydraulic oil return tube. Install the hydraulic oil return tube P-clamp (1).

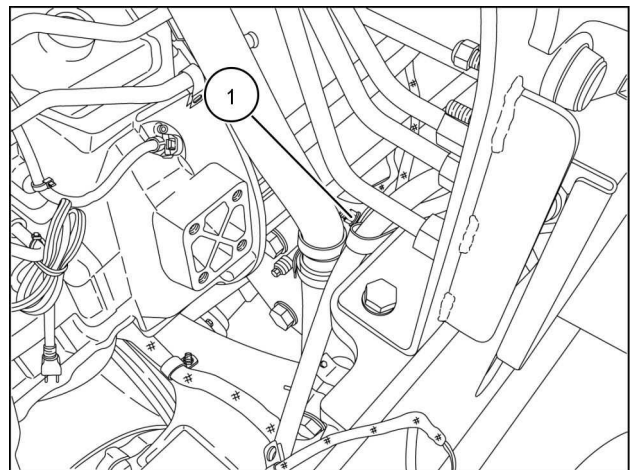

RCPH11WHL050AAR 8

11. Install the air box snorkel (1). Install two bolts (2), washers (3), and nuts (4).

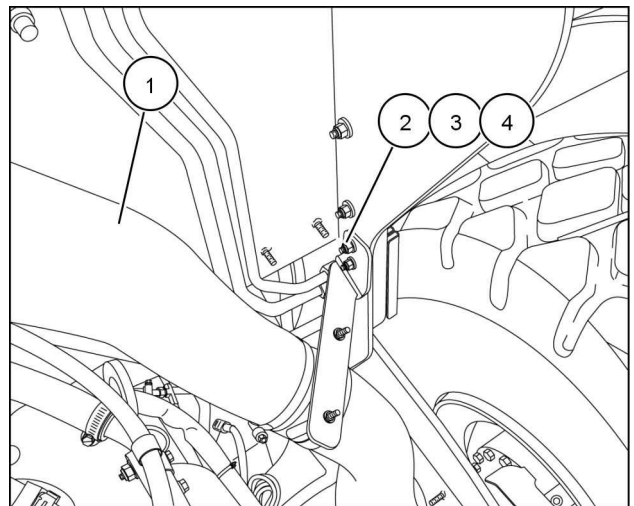

RCPH11WHL023AAR 9

12. Install the turbo exhaust tube (1).
13. Tighten the turbo muffler clamp (2) to a torque of **5 - 6 N·m (44 - 53 lb in)**.

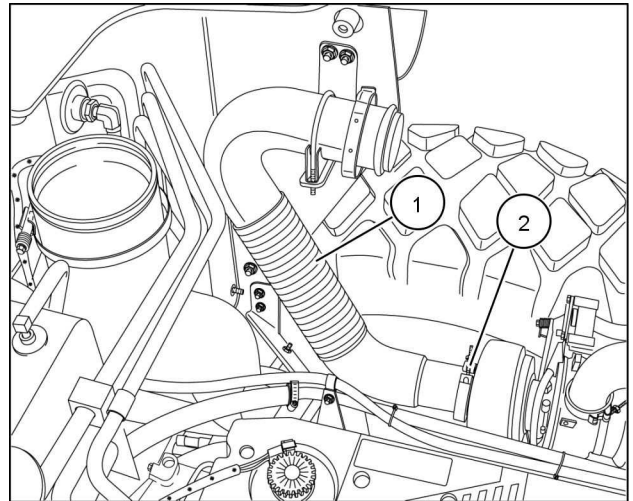

RCPH11WHL022AAR 10

14. Remove lifting equipment (1) from the engine.

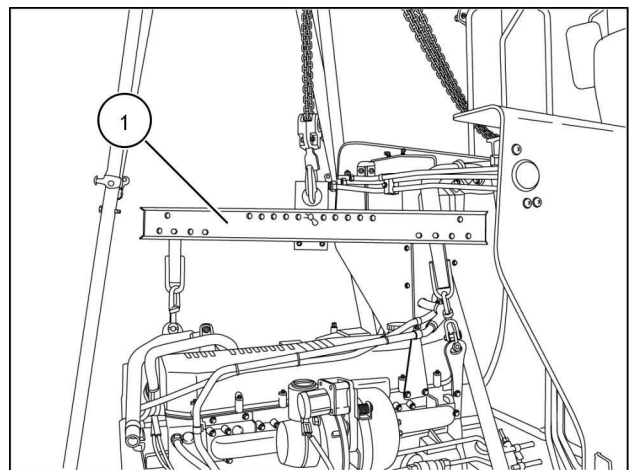

RCPH11WHL048AAR 11

15. Install the engine wall.

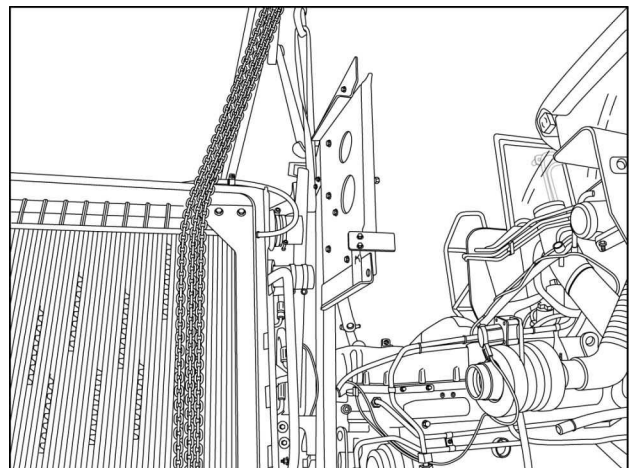

RCPH11WHL039AAR 12

16. Install the lower radiator tube (1).

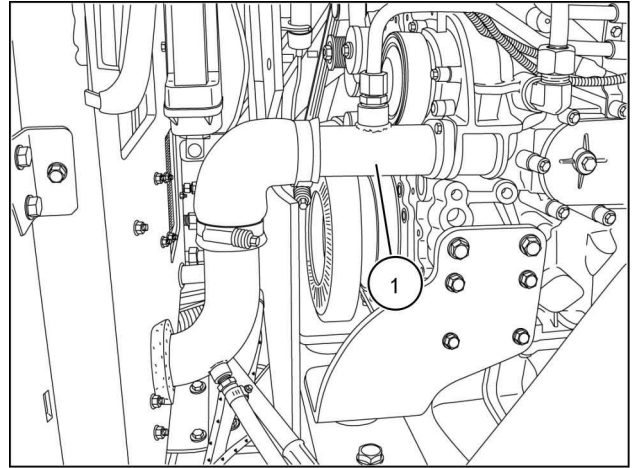

RCPH11WHL021AAR 13

17. Install the air box.

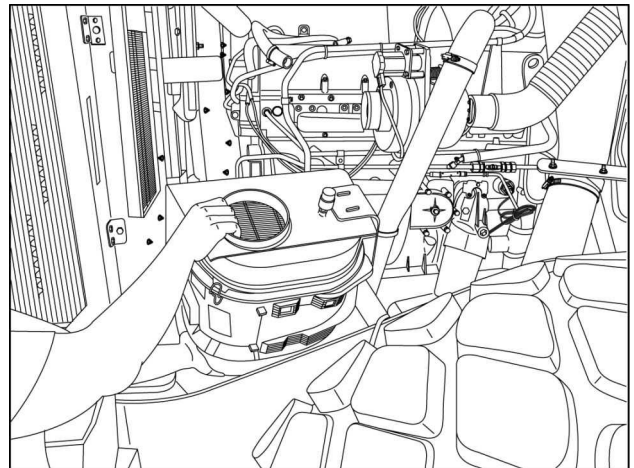

RCPH11WHL019AAR 14

18. Install the wire harness P-clamp (1) .
19. Connect the air intake hose (3). Tighten the hose clamp on the air intake hose (2) to a torque of **4 - 5 N·m (35 - 40 lb in)**.

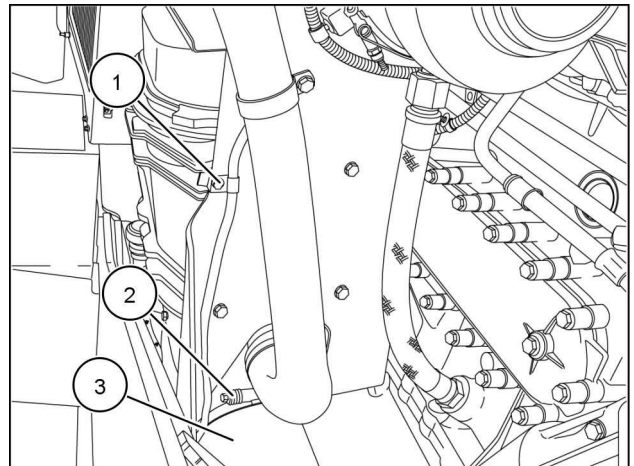

RCPH11WHL018AAR 15

20. Install the lower, right panel (1) on the engine wall.

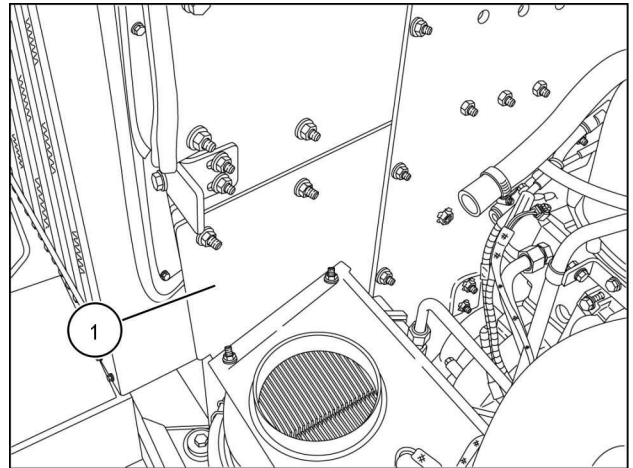

RCPH11WHL020AAR 16

21. Install the turbo inlet tube (2).
22. Tighten the air intake hose clamp (3) to a torque of **4 - 5 N·m (35 - 40 lb in)**.
23. Connect the humidity sensor electrical connector (1).
24. Connect the air filter restriction sensor electrical connector (4).

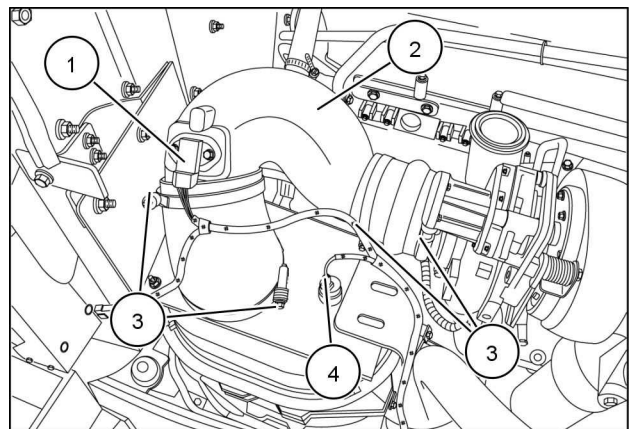

RCPH11WHL017AAR 17

25. Install the upper radiator tube (2).
26. Install the before air cooler tube (1).

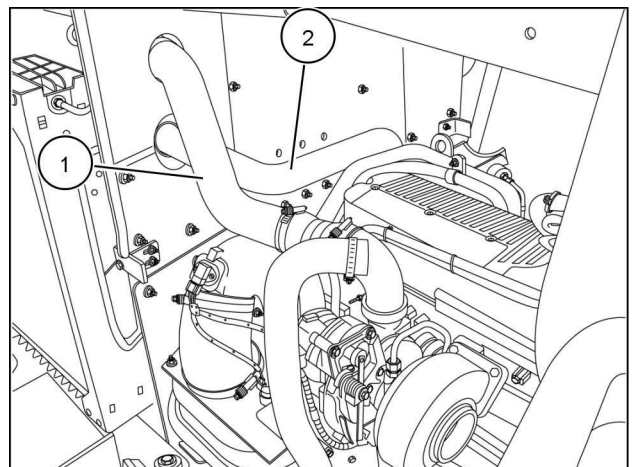

RCPH11WHL016AAR 18

27. Install the engine oil drain tube (1).

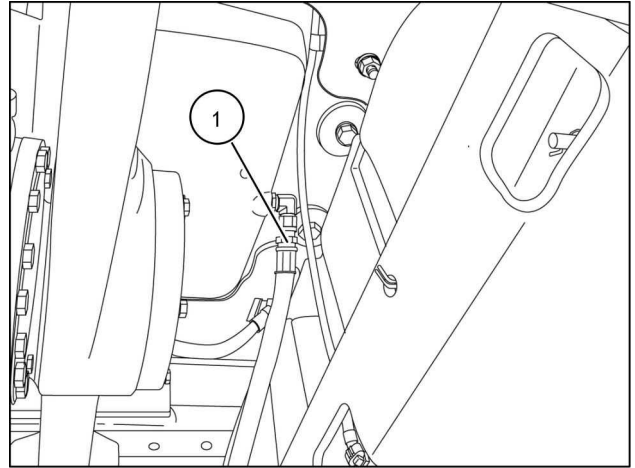

RCPH11WHL047AAR 19

28. Install the wire harness P-clamps (1).

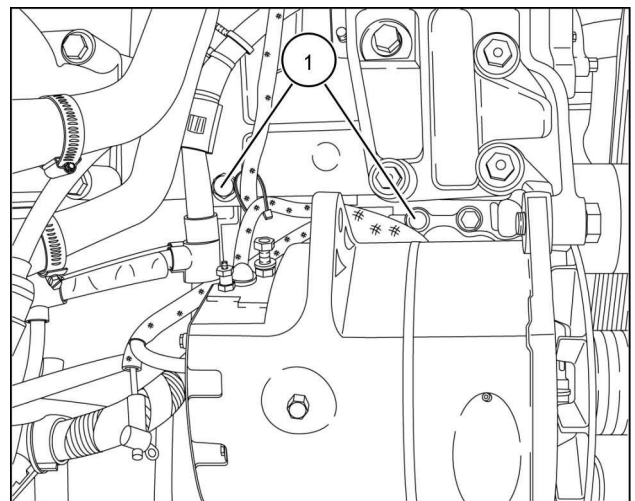

RCPH11WHL046AAR 20

29. Install the engine serpentine belt (1).

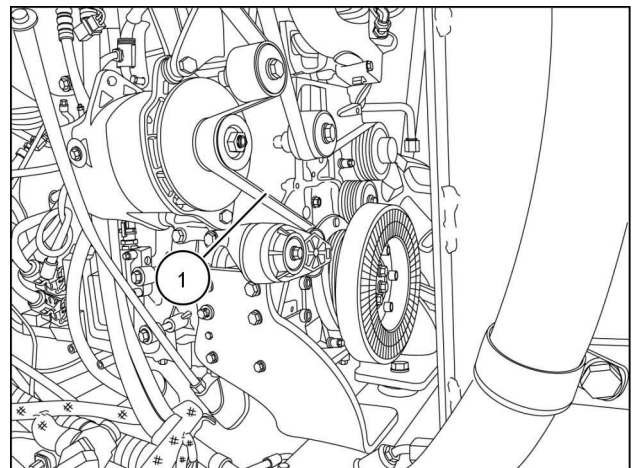

RCPH11WHL051AAR 21

30. Install the A/C compressor (2).
31. Connect the A/C compressor electrical connector (1).
32. Connect the A/C pressure switch electrical connector (4).
33. Connect the alternator power wire (3). Tighten the nut to a torque of **6 - 8 N·m (55 - 70 lb in)**.
34. Connect the bulk electrical connector (5).

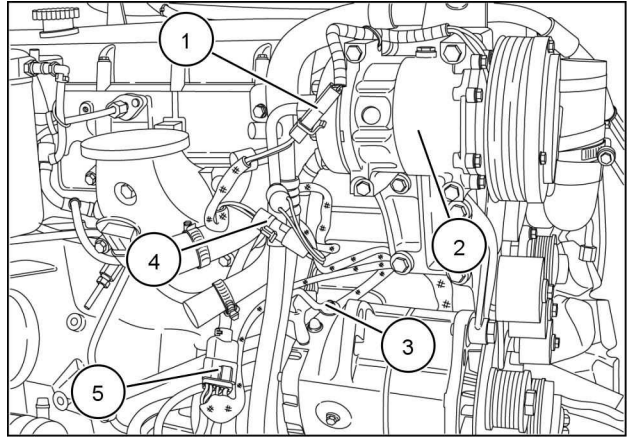

RCPH11WHL045AAR 22

35. Connect the engine ground wires (1).
36. Install the wire harness P-clamp (2).

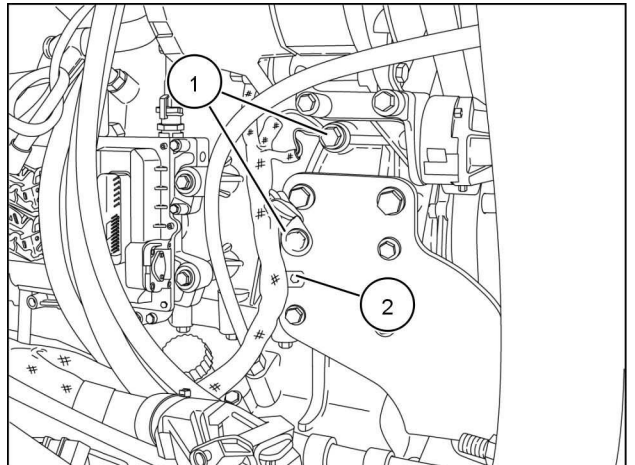

RCPH11WHL043AAR 23

37. Connect the fuel return line (1).
38. Connect the battery positive wire (2) on the air grid heater.

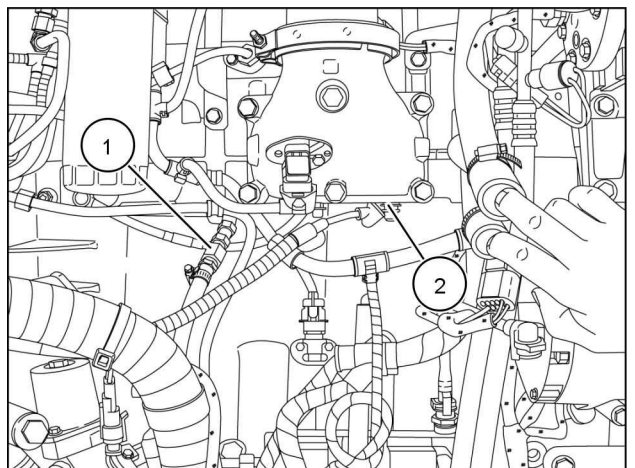

RCPH11WHL042AAR 24

39. Connect the engine control module electrical connector (1).

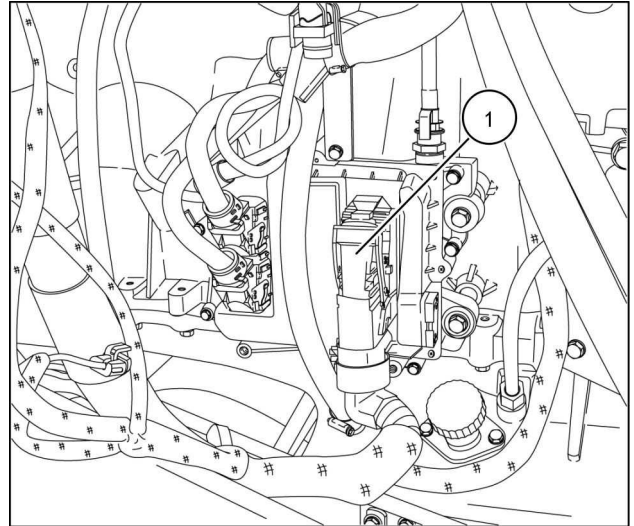

RCPH11WHL041AAR 25

40. Install the crank case ventilation/fuel filter bracket assembly.

41. Connect the following on the crank case ventilation/fuel filter assembly:

- Fuel pump electrical connector
- Water sensor electrical connector
- Ground wire
- Wire harness P-clamp
- Crankcase filter inlet hose
- Crankcase filter outlet hose
- Crankcase filter oil return hose
- Fuel pump inlet tube
- Fuel pump outlet tube

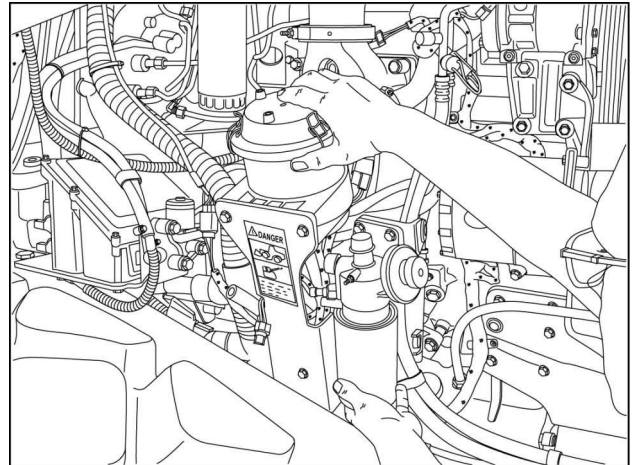

RCPH11WHL040AAR 26

42. Connect the starter battery cables (1) and starter switch wire (2).

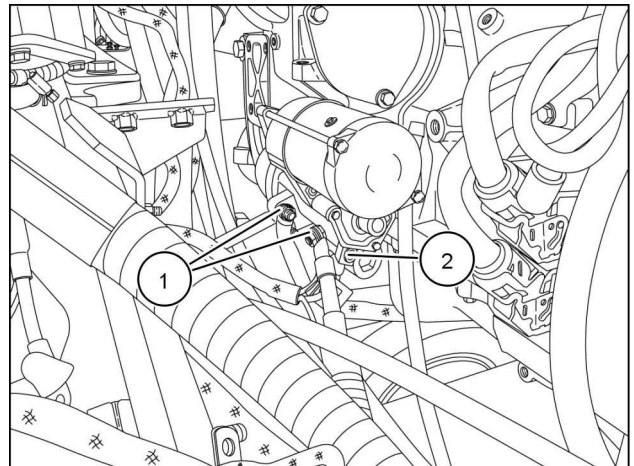

RCPH11WHL049AAR 27

43. Connect the hood lift strut electrical connector **(2)**.
44. Slip the oil dipstick tube **(1)** through the engine wall. Install the dipstick tube P-clamp **(3)**.

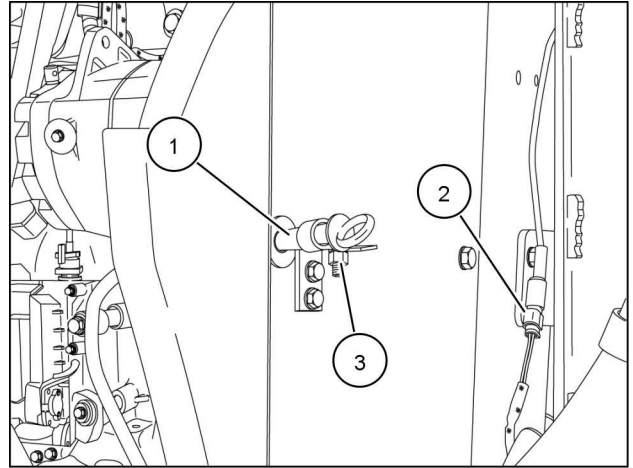

RCPH11WHL015AAR 28

45. Install the bulkheads **(2)**.
46. Install the after air cooler tube **(1)**.

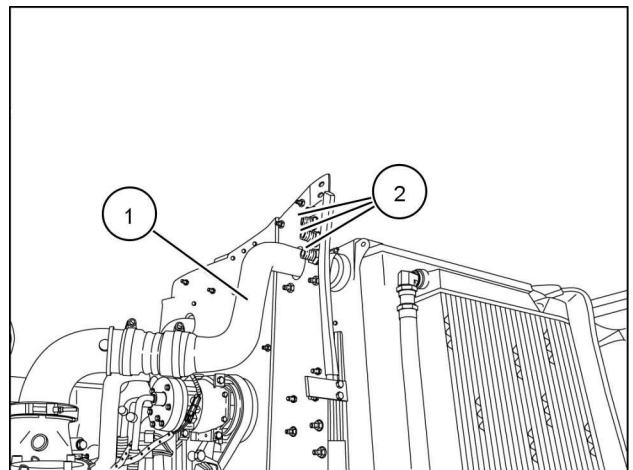

RCPH11WHL014AAR 29

47. Install the hydraulic lines **(1)**.

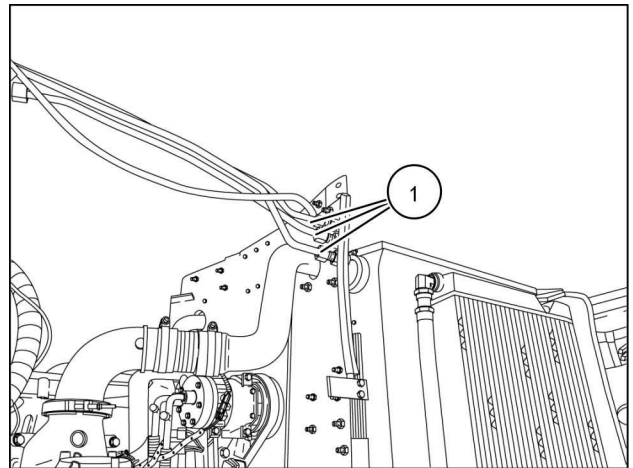

RCPH11WHL013AAR 30

48. Install the left bracket **(1)** and right bracket **(2)**.

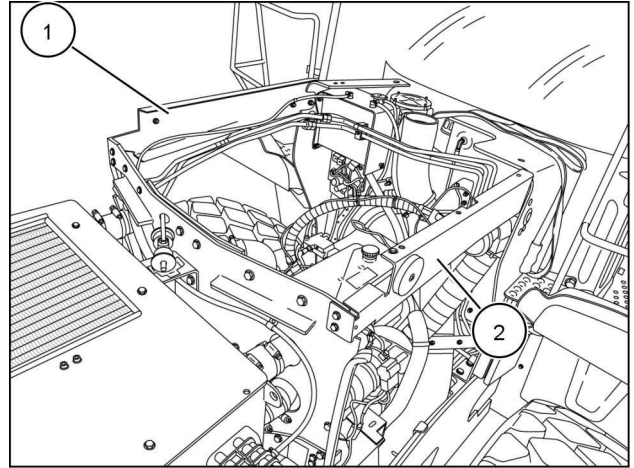

RCPH11WHL012AAR 31

49. Install the P-clamps **(2)** and overflow tube **(1)** to the engine wall, left bracket, and deaeration tank **(3)**.

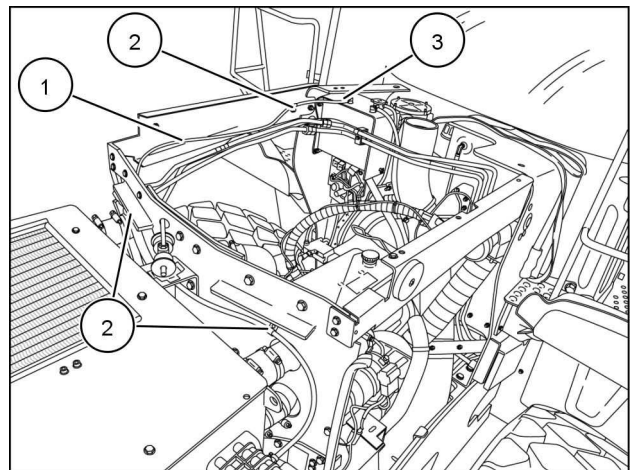

RCPH11WHL012AAR 32

50. Install the muffler assembly.
51. Lower the exhaust stack hood **(1)** in front of the engine wall and onto the left bracket, right bracket, and hydraulic oil tank.
52. Install the exhaust stack hood mounting bolts.

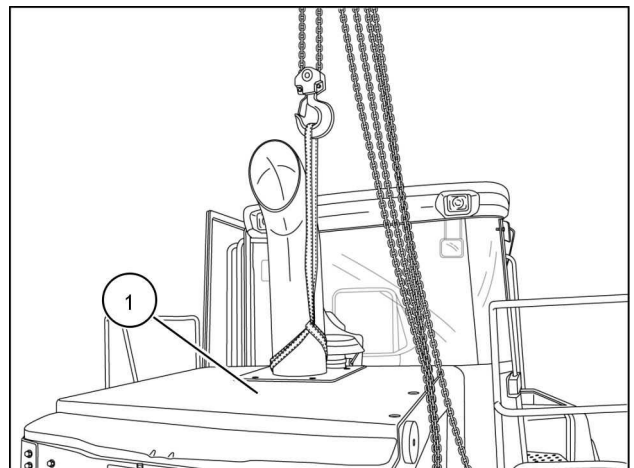

RCPH11WHL010AAR 33

This as a preview PDF file from best-manuals.com



Download full PDF manual at best-manuals.com