

# SERVICE MANUAL

**T4.75 / T4.85 / T4.95 / T4.105 / T4.115**

**Tractor**

*PIN ZDJT13873 and above*

Part number 47803847

English

November 2014





## SERVICE MANUAL

**T4.105 less cab, with mechanical or power shuttle transmission [ZxJT0xxxx], T4.105 with cab, with mechanical or power shuttle transmission [ZxJT0xxxx], T4.105 with cab, with hi-lo transmission [ZxJT0xxxx], T4.105 with cab, with hi-lo transmission, with Supersteer™ front axle [ZxJT0xxxx], T4.105 less cab, with hi-lo transmission [ZxJT0xxxx], T4.115 less cab, with mechanical or power shuttle transmission [ZxJT0xxxx], T4.115 with cab, with mechanical or power shuttle transmission [ZxJT0xxxx], T4.115 less cab, with hi-lo transmission [ZxJT0xxxx], T4.115 with cab, with hi-lo transmission [ZxJT0xxxx], T4.115 with cab, with hi-lo transmission, with Supersteer™ front axle [ZxJT0xxxx], T4.75 less cab, with mechanical or power shuttle transmission [ZxJT0xxxx], T4.75 with cab, with mechanical or power shuttle transmission [ZxJT0xxxx], T4.75 with cab, with hi-lo transmission [ZxJT0xxxx], T4.75 with cab, with hi-lo transmission, with Supersteer™ front axle [ZxJT0xxxx], T4.75 less cab, with hi-lo transmission [ZxJT0xxxx], T4.85 less cab, with mechanical or power shuttle transmission [ZxJT0xxxx], T4.85 with cab, with mechanical or power shuttle transmission [ZxJT0xxxx], T4.85 with cab, with hi-lo transmission [ZxJT0xxxx], T4.85 with cab, with hi-lo transmission, with Supersteer™ front axle [ZxJT0xxxx], T4.85 less cab, with hi-lo transmission [ZxJT0xxxx], T4.95 less cab, with mechanical or power shuttle transmission [ZxJT0xxxx], T4.95 with cab, with mechanical or power shuttle transmission [ZxJT0xxxx], T4.95 with cab, with hi-lo transmission [ZxJT0xxxx], T4.95 with cab, with hi-lo transmission, with Supersteer™ front axle [ZxJT0xxxx], T4.95 less cab, with hi-lo transmission [ZxJT0xxxx]**

## Link Product / Engine

| Product   | Market Product        | Engine         |
|---|-----------------------|----------------|
| T4.105 senza cabina, con trasmissione meccanica o Power Shuttle [ZxJT0xxxx]             | Australia New Zealand | F5DFL413L*A001 |
| T4.105 senza cabina, con trasmissione meccanica o Power Shuttle [ZxJT0xxxx]             | Asia Pacific          | F5DFL413L*A001 |
| T4.105 senza cabina, con trasmissione meccanica o Power Shuttle [ZxJT0xxxx]             | Middle East Africa    | F5DFL413L*A001 |
| T4.105 senza cabina, con trasmissione meccanica o Power Shuttle [ZxJT0xxxx]             | Europe                | F5DFL413L*A001 |
| T4.105 con cabina, con trasmissione meccanica o Power Shuttle [ZxJT0xxxx]               | Asia Pacific          | F5DFL413L*A001 |
| T4.105 con cabina, con trasmissione meccanica o Power Shuttle [ZxJT0xxxx]               | Australia New Zealand | F5DFL413L*A001 |
| T4.105 con cabina, con trasmissione meccanica o Power Shuttle [ZxJT0xxxx]               | Europe                | F5DFL413L*A001 |
| T4.105 con cabina, con trasmissione meccanica o Power Shuttle [ZxJT0xxxx]               | Middle East Africa    | F5DFL413L*A001 |
| T4.105 con cabina, con trasmissione hi-lo [ZxJT0xxxx]                                   | Europe                | F5DFL413L*A001 |
| T4.105 con cabina, con trasmissione hi-lo [ZxJT0xxxx]                                   | Middle East Africa    | F5DFL413L*A001 |
| T4.105 con cabina, con trasmissione hi-lo [ZxJT0xxxx]                                   | Asia Pacific          | F5DFL413L*A001 |
| T4.105 con cabina, con trasmissione hi-lo [ZxJT0xxxx]                                   | Australia New Zealand | F5DFL413L*A001 |
| T4.105 con cabina, con trasmissione hi-lo, con assale anteriore Supersteer™ [ZxJT0xxxx] | Europe                | F5DFL413L*A001 |
| T4.105 con cabina, con trasmissione hi-lo, con assale anteriore Supersteer™ [ZxJT0xxxx] | Asia Pacific          | F5DFL413L*A001 |
| T4.105 con cabina, con trasmissione hi-lo, con assale anteriore Supersteer™ [ZxJT0xxxx] | Middle East Africa    | F5DFL413L*A001 |
| T4.105 con cabina, con trasmissione hi-lo, con assale anteriore Supersteer™ [ZxJT0xxxx] | Australia New Zealand | F5DFL413L*A001 |

| <b>Product</b>   | <b>Market Product</b> | <b>Engine</b>  |
|--|-----------------------|----------------|
| T4.105 senza cabina, con trasmissione hi-lo [ZxJT0xxxx]                                | Middle East Africa    | F5DFL413L*A001 |
| T4.105 senza cabina, con trasmissione hi-lo [ZxJT0xxxx]                                | Australia New Zealand | F5DFL413L*A001 |
| T4.105 senza cabina, con trasmissione hi-lo [ZxJT0xxxx]                                | Europe                | F5DFL413L*A001 |
| T4.105 senza cabina, con trasmissione hi-lo [ZxJT0xxxx]                                | Asia Pacific          | F5DFL413L*A001 |
| T4.75 senza cabina, con trasmissione meccanica o Power Shuttle [ZxJT0xxxx]             | Asia Pacific          | F5DFL413H*A002 |
| T4.75 senza cabina, con trasmissione meccanica o Power Shuttle [ZxJT0xxxx]             | Europe                | F5DFL413H*A002 |
| T4.75 senza cabina, con trasmissione meccanica o Power Shuttle [ZxJT0xxxx]             | Australia New Zealand | F5DFL413H*A002 |
| T4.75 senza cabina, con trasmissione meccanica o Power Shuttle [ZxJT0xxxx]             | Middle East Africa    | F5DFL413H*A002 |
| T4.75 con cabina, con trasmissione meccanica o Power Shuttle [ZxJT0xxxx]               | Middle East Africa    | F5DFL413H*A002 |
| T4.75 con cabina, con trasmissione meccanica o Power Shuttle [ZxJT0xxxx]               | Europe                | F5DFL413H*A002 |
| T4.75 con cabina, con trasmissione meccanica o Power Shuttle [ZxJT0xxxx]               | Asia Pacific          | F5DFL413H*A002 |
| T4.75 con cabina, con trasmissione meccanica o Power Shuttle [ZxJT0xxxx]               | Australia New Zealand | F5DFL413H*A002 |
| T4.75 con cabina, con trasmissione hi-lo [ZxJT0xxxx]                                   | Australia New Zealand | F5DFL413H*A002 |
| T4.75 con cabina, con trasmissione hi-lo [ZxJT0xxxx]                                   | Middle East Africa    | F5DFL413H*A002 |
| T4.75 con cabina, con trasmissione hi-lo [ZxJT0xxxx]                                   | Europe                | F5DFL413H*A002 |
| T4.75 con cabina, con trasmissione hi-lo [ZxJT0xxxx]                                   | Asia Pacific          | F5DFL413H*A002 |
| T4.75 con cabina, con trasmissione hi-lo, con assale anteriore Supersteer™ [ZxJT0xxxx] | Australia New Zealand | F5DFL413H*A002 |
| T4.75 con cabina, con trasmissione hi-lo, con assale anteriore Supersteer™ [ZxJT0xxxx] | Middle East Africa    | F5DFL413H*A002 |
| T4.75 con cabina, con trasmissione hi-lo, con assale anteriore Supersteer™ [ZxJT0xxxx] | Asia Pacific          | F5DFL413H*A002 |
| T4.75 con cabina, con trasmissione hi-lo, con assale anteriore Supersteer™ [ZxJT0xxxx] | Europe                | F5DFL413H*A002 |

| <b>Product</b>   | <b>Market Product</b> | <b>Engine</b>  |
|--|-----------------------|----------------|
| T4.75 senza cabina, con trasmissione hi-lo [ZxJT0xxxx]                                 | Asia Pacific          | F5DFL413H*A002 |
| T4.75 senza cabina, con trasmissione hi-lo [ZxJT0xxxx]                                 | Middle East Africa    | F5DFL413H*A002 |
| T4.75 senza cabina, con trasmissione hi-lo [ZxJT0xxxx]                                 | Europe                | F5DFL413H*A002 |
| T4.75 senza cabina, con trasmissione hi-lo [ZxJT0xxxx]                                 | Australia New Zealand | F5DFL413H*A002 |
| T4.85 senza cabina, con trasmissione meccanica o Power Shuttle [ZxJT0xxxx]             | Europe                | F5DFL413J*A001 |
| T4.85 senza cabina, con trasmissione meccanica o Power Shuttle [ZxJT0xxxx]             | Middle East Africa    | F5DFL413J*A001 |
| T4.85 senza cabina, con trasmissione meccanica o Power Shuttle [ZxJT0xxxx]             | Australia New Zealand | F5DFL413J*A001 |
| T4.85 senza cabina, con trasmissione meccanica o Power Shuttle [ZxJT0xxxx]             | Asia Pacific          | F5DFL413J*A001 |
| T4.85 con cabina, con trasmissione meccanica o Power Shuttle [ZxJT0xxxx]               | Asia Pacific          | F5DFL413J*A001 |
| T4.85 con cabina, con trasmissione meccanica o Power Shuttle [ZxJT0xxxx]               | Europe                | F5DFL413J*A001 |
| T4.85 con cabina, con trasmissione meccanica o Power Shuttle [ZxJT0xxxx]               | Middle East Africa    | F5DFL413J*A001 |
| T4.85 con cabina, con trasmissione meccanica o Power Shuttle [ZxJT0xxxx]               | Australia New Zealand | F5DFL413J*A001 |
| T4.85 con cabina, con trasmissione hi-lo [ZxJT0xxxx]                                   | Australia New Zealand | F5DFL413J*A001 |
| T4.85 con cabina, con trasmissione hi-lo [ZxJT0xxxx]                                   | Asia Pacific          | F5DFL413J*A001 |
| T4.85 con cabina, con trasmissione hi-lo [ZxJT0xxxx]                                   | Middle East Africa    | F5DFL413J*A001 |
| T4.85 con cabina, con trasmissione hi-lo [ZxJT0xxxx]                                   | Europe                | F5DFL413J*A001 |
| T4.85 con cabina, con trasmissione hi-lo, con assale anteriore Supersteer™ [ZxJT0xxxx] | Australia New Zealand | F5DFL413J*A001 |
| T4.85 con cabina, con trasmissione hi-lo, con assale anteriore Supersteer™ [ZxJT0xxxx] | Europe                | F5DFL413J*A001 |
| T4.85 con cabina, con trasmissione hi-lo, con assale anteriore Supersteer™ [ZxJT0xxxx] | Asia Pacific          | F5DFL413J*A001 |
| T4.85 con cabina, con trasmissione hi-lo, con assale anteriore Supersteer™ [ZxJT0xxxx] | Middle East Africa    | F5DFL413J*A001 |

| <b>Product</b>   | <b>Market Product</b> | <b>Engine</b>  |
|--|-----------------------|----------------|
| T4.85 senza cabina, con trasmissione hi-lo [ZxJT0xxxx]                                 | Australia New Zealand | F5DFL413J*A001 |
| T4.85 senza cabina, con trasmissione hi-lo [ZxJT0xxxx]                                 | Europe                | F5DFL413J*A001 |
| T4.85 senza cabina, con trasmissione hi-lo [ZxJT0xxxx]                                 | Asia Pacific          | F5DFL413J*A001 |
| T4.85 senza cabina, con trasmissione hi-lo [ZxJT0xxxx]                                 | Middle East Africa    | F5DFL413J*A001 |
| T4.95 senza cabina, con trasmissione meccanica o Power Shuttle [ZxJT0xxxx]             | Asia Pacific          | F5DFL413K*A001 |
| T4.95 senza cabina, con trasmissione meccanica o Power Shuttle [ZxJT0xxxx]             | Europe                | F5DFL413K*A001 |
| T4.95 senza cabina, con trasmissione meccanica o Power Shuttle [ZxJT0xxxx]             | Middle East Africa    | F5DFL413K*A001 |
| T4.95 senza cabina, con trasmissione meccanica o Power Shuttle [ZxJT0xxxx]             | Australia New Zealand | F5DFL413K*A001 |
| T4.95 con cabina, con trasmissione meccanica o Power Shuttle [ZxJT0xxxx]               | Middle East Africa    | F5DFL413K*A001 |
| T4.95 con cabina, con trasmissione meccanica o Power Shuttle [ZxJT0xxxx]               | Asia Pacific          | F5DFL413K*A001 |
| T4.95 con cabina, con trasmissione meccanica o Power Shuttle [ZxJT0xxxx]               | Europe                | F5DFL413K*A001 |
| T4.95 con cabina, con trasmissione meccanica o Power Shuttle [ZxJT0xxxx]               | Australia New Zealand | F5DFL413K*A001 |
| T4.95 con cabina, con trasmissione hi-lo [ZxJT0xxxx]                                   | Europe                | F5DFL413K*A001 |
| T4.95 con cabina, con trasmissione hi-lo [ZxJT0xxxx]                                   | Middle East Africa    | F5DFL413K*A001 |
| T4.95 con cabina, con trasmissione hi-lo [ZxJT0xxxx]                                   | Australia New Zealand | F5DFL413K*A001 |
| T4.95 con cabina, con trasmissione hi-lo [ZxJT0xxxx]                                   | Asia Pacific          | F5DFL413K*A001 |
| T4.95 con cabina, con trasmissione hi-lo, con assale anteriore Supersteer™ [ZxJT0xxxx] | Australia New Zealand | F5DFL413K*A001 |
| T4.95 con cabina, con trasmissione hi-lo, con assale anteriore Supersteer™ [ZxJT0xxxx] | Middle East Africa    | F5DFL413K*A001 |
| T4.95 con cabina, con trasmissione hi-lo, con assale anteriore Supersteer™ [ZxJT0xxxx] | Asia Pacific          | F5DFL413K*A001 |
| T4.95 con cabina, con trasmissione hi-lo, con assale anteriore Supersteer™ [ZxJT0xxxx] | Europe                | F5DFL413K*A001 |

| <b>Product</b>   | <b>Market Product</b> | <b>Engine</b>  |
|--|-----------------------|----------------|
| T4.95 senza cabina, con trasmissione hi-lo [ZxJT0xxxx] | Europe                | F5DFL413K*A001 |
| T4.95 senza cabina, con trasmissione hi-lo [ZxJT0xxxx] | Asia Pacific          | F5DFL413K*A001 |
| T4.95 senza cabina, con trasmissione hi-lo [ZxJT0xxxx] | Middle East Africa    | F5DFL413K*A001 |
| T4.95 senza cabina, con trasmissione hi-lo [ZxJT0xxxx] | Australia New Zealand | F5DFL413K*A001 |

# Contents

---

## INTRODUCTION

|  |           |
|--|-----------|
| <b>Engine</b> .....  | <b>10</b> |
| [10.001] Engine and crankcase .....  | 10.1      |
| [10.216] Fuel tanks .....  | 10.2      |
| [10.501] Exhaust Gas Recirculation (EGR) - Diesel Particulate Filter (DPF) exhaust treatment ..... | 10.3      |
| [10.414] Fan and drive .....   | 10.4      |
| <b>Clutch</b> .....  | <b>18</b> |
| [18.100] Clutch mechanical release control .....   | 18.1      |
| [18.104] Clutch hydraulic release control.....   | 18.2      |
| [18.110] Clutch and components .....   | 18.3      |
| <b>Transmission</b> .....  | <b>21</b> |
| [21.130] Mechanical transmission external controls.....  | 21.1      |
| [21.112] Power shuttle transmission.....   | 21.2      |
| [21.110] Master clutch housing .....   | 21.3      |
| [21.134] Power shuttle transmission external controls .....  | 21.4      |
| [21.154] Power shuttle transmission internal components .....                                      | 21.5      |
| [21.160] Creeper .....   | 21.6      |
| [21.162] Reverser .....  | 21.7      |
| [21.168] Hi-Lo unit.....   | 21.8      |
| [21.109] Transmission cooler and lines.....  | 21.9      |
| [21.118] Transmission/Rear drive .....   | 21.10     |
| [21.148] Transmission/Rear drive internal components .....   | 21.11     |
| [21.AAA] Transmission generic sub-group .....  | 21.12     |
| <b>Four-Wheel Drive (4WD) system</b> .....   | <b>23</b> |
| [23.202] Electro-hydraulic control .....   | 23.1      |
| [23.314] Drive shaft.....  | 23.2      |



|   |           |
|---|-----------|
| <b>Front axle system .....</b>                                | <b>25</b> |
| [25.100] Powered front axle .....                             | 25.1      |
| [25.102] Front bevel gear set and differential .....          | 25.2      |
| [25.108] Final drive hub, steering knuckles, and shafts ..... | 25.3      |
| [25.400] Non-powered front axle .....                         | 25.4      |
| <b>Rear axle system.....</b>                                  | <b>27</b> |
| [27.106] Rear bevel gear set and differential.....            | 27.1      |
| [27.120] Planetary and final drives .....                     | 27.2      |
| [27.100] Powered rear axle.....                               | 27.3      |
| <b>Power Take-Off (PTO).....</b>                              | <b>31</b> |
| [31.101] Rear mechanical control .....                        | 31.1      |
| [31.104] Rear electro-hydraulic control.....                  | 31.2      |
| [31.110] One-speed rear Power Take-Off (PTO) .....            | 31.3      |
| [31.114] Two-speed rear Power Take-Off (PTO) .....            | 31.4      |
| [31.146] Front Power Take-Off (PTO) .....                     | 31.5      |
| <b>Brakes and controls .....</b>                              | <b>33</b> |
| [33.202] Hydraulic service brakes .....                       | 33.1      |
| [33.110] Parking brake or parking lock .....                  | 33.2      |
| [33.220] Trailer brake hydraulic control.....                 | 33.3      |
| [33.224] Trailer brake pneumatic control .....                | 33.4      |
| <b>Hydraulic systems.....</b>                                 | <b>35</b> |
| [35.000] Hydraulic systems.....                               | 35.1      |
| [35.104] Fixed displacement pump.....                         | 35.2      |
| [35.160] Front hitch controls and lines .....                 | 35.3      |
| [35.204] Remote control valves .....                          | 35.4      |
| [35.114] Three-point hitch control valve .....                | 35.5      |
| [35.116] Three-point hitch cylinder .....                     | 35.6      |
| [35.701] Front loader arm hydraulic system .....              | 35.7      |

|   |           |
|---|-----------|
| [35.723] Front loader bucket hydraulic system .....     | 35.8      |
| <b>Hitches, drawbars, and implement couplings.....</b>  | <b>37</b> |
| [37.100] Drawbars and towing hitches .....              | 37.1      |
| [37.110] Rear three-point hitch .....                   | 37.2      |
| [37.162] Front hitch .....                              | 37.3      |
| [37.166] Front hitch linkage.....                       | 37.4      |
| <b>Steering.....</b>                                    | <b>41</b> |
| [41.101] Steering control .....                         | 41.1      |
| [41.106] Tie rods.....                                  | 41.2      |
| [41.200] Hydraulic control components.....              | 41.3      |
| [41.206] Pump .....                                     | 41.4      |
| [41.216] Cylinders .....                                | 41.5      |
| <b>Wheels .....</b>                                     | <b>44</b> |
| [44.511] Front wheels.....                              | 44.1      |
| [44.520] Rear wheels .....                              | 44.2      |
| <b>Cab climate control .....</b>                        | <b>50</b> |
| [50.100] Heating .....                                  | 50.1      |
| [50.104] Ventilation .....                              | 50.2      |
| [50.200] Air conditioning.....                          | 50.3      |
| <b>Electrical systems .....</b>                         | <b>55</b> |
| [55.032] Trailer brake electrical system .....          | 55.1      |
| [55.100] Harnesses and connectors.....                  | 55.2      |
| [55.201] Engine starting system .....                   | 55.3      |
| [55.301] Alternator.....                                | 55.4      |
| [55.302] Battery.....                                   | 55.5      |
| [55.640] Electronic modules .....                       | 55.6      |
| [55.048] Rear Power Take-Off (PTO) control system ..... | 55.7      |
| [55.160] Front hitch electronic control system.....     | 55.8      |

|  |           |
|--|-----------|
| [55.408] Warning indicators, alarms, and instruments ..... | 55.9      |
| [55.DTC] FAULT CODES.....                                  | 55.10     |
| <b>Front loader and bucket.....</b>                        | <b>82</b> |
| [82.100] Arm.....  | 82.1      |
| [82.300] Bucket.....                                       | 82.2      |
| [82.AAA] Front loader and bucket generic sub-group .....   | 82.3      |
| <b>Platform, cab, bodywork, and decals .....</b>           | <b>90</b> |
| [90.150] Cab.....  | 90.1      |
| [90.151] Cab interior.....                                 | 90.2      |
| [90.160] Cab interior trim and panels.....                 | 90.3      |
| [90.154] Cab doors and hatches .....                       | 90.4      |
| [90.110] Operator platform less cab .....                  | 90.5      |
| [90.100] Engine hood and panels .....                      | 90.6      |



# INTRODUCTION

# Contents

---

## INTRODUCTION

|  |    |
|--|----|
| Advice .....   | 3  |
| Note to the Owner WARNINGS FOR AIR CONDITIONING SYSTEM REPAIR OPERATIONS | 4  |
| Safety rules SAFETY REGULATIONS .....                                    | 5  |
| Personal safety CAB AIR CONDITIONING SYSTEM .....                        | 8  |
| Basic instructions .....   | 9  |
| Special tools NOTES FOR EQUIPMENT .....                                  | 11 |
| Consumables .....  | 12 |
| Part identification .....  | 13 |

## **Advice**

### **IMPORTANT NOTICE**

All maintenance and repair work described in this manual must be performed exclusively by NEW HOLLAND service technicians, in strict accordance with the instructions given and using any specific tools necessary. Anyone performing the operations described herein without strictly following the instructions is personally responsible for any eventual injury or damage to property.

---

## **Note to the Owner WARNINGS FOR AIR CONDITIONING SYSTEM REPAIR OPERATIONS**

Starting the system at low temperatures can damage the compressor. Only operate the air conditioner when the engine is hot and the temperature inside the cab is at least **20 °C (68.00 °F)**.

When disconnecting the hoses, close the ends with plastic caps to prevent foreign matter and humidity from getting inside the hoses.

Handle the thermostatic sensor carefully to avoid damage that may prevent efficient system operation.

Always use two spanners to unscrew the hose fittings to avoid twisting the fitting.

Do not use any type of engine oil to lubricate the compressor and the system.

Never leave the compressor oil container open, always make sure that it is tightly closed. If left exposed the oil will absorb humidity from the air and may, subsequently, damage the system.

Do not transfer compressor oil from the original container to another container.

Do not introduce any additives to the compressor oil. Any additional substances could contain elements which are incompatible with the chemical base of the refrigerant and thus alter its characteristics.

Check that the thermostatic sensor is correctly inserted in the fins on the evaporator to ensure efficient system operation.

---

## Safety rules SAFETY REGULATIONS

### TO PREVENT ACCIDENTS

Most accidents or injuries that occur in workshops are the result of non-observance of simple and fundamental safety regulations.

For this reason, IN MOST CASES THESE ACCIDENTS CAN BE AVOIDED: by foreseeing possible causes and consequently acting with the necessary caution and care.

Accidents may occur with all types of vehicle, regardless of how well it was designed and built.

A careful and judicious service technician is the best guarantee against accidents.

Precise observance of the most basic safety rule is normally sufficient to avoid many serious accidents.

DANGER: Never carry out any cleaning, lubrication or maintenance operations when the engine is running.

### GENERAL

- Carefully follow specified repair and maintenance procedures.
- Do not wear rings, wristwatches, jewellery, unbuttoned or loose articles of clothing such as: ties, torn clothing, scarves, open jackets or shirts with open zips that may remain entangled in moving parts.  
It is advised to wear approved safety clothing, e.g: non-slip footwear, gloves, safety goggles, helmets, etc.
- Do not carry out repair operations with someone sitting in the driver's seat, unless the person is a trained technician who is assisting with the operation in question.
- Operate the vehicle and use the implements exclusively from the driver's seat.
- Do not carry out operations on the vehicle with the engine running, unless specifically indicated.
- Stop the engine and ensure that all pressure is relieved from hydraulic circuits before removing caps, covers, valves, etc.
- All repair and maintenance operations must be carried out using extreme care and attention.
- Service steps and platforms used in a workshop or in the field should be built in compliance with the safety rules in force.
- Disconnect the batteries and label all controls to indicate that the vehicle is being serviced. Block the machine and all equipment which should be raised.
- Do not check or fill fuel tanks, accumulator batteries, nor use starting liquid when smoking or near naked flames, as these fluids are inflammable.
- Brakes are inoperative if manually released for repair or maintenance purposes.  
In such cases, the machine should be kept constantly under control using blocks or similar devices.
- The fuel nozzle should always be in contact with the filling aperture. Maintain this position until filling operations are completed in order to avoid possible sparks caused by the accumulation of static electricity.
- Only use specified towing points for towing the tractor, connect parts carefully. Make sure that all pins and/or locks are secured in position before applying traction.  
Never remain near the towing bars, cables or chains that are operating under load
- Transport vehicles that cannot be driven using a trailer or a low-loading platform trolley, if available.
- When loading or unloading the vehicle from the trailer (or other means of transport), select a flat area capable of sustaining the trailer or truck wheels, firmly secure the tractor to the truck or trailer and lock the wheels in the position.
- Electric heaters, battery-chargers and similar equipment must only be powered by auxiliary power supplies with efficient ground insulation to avoid electrical shock hazards.
- Always use suitable hoisting or lifting devices when raising or moving heavy parts.
- Take extra care if bystanders are present.
- Never pour gasoline or diesel oil into open, wide and low containers.
- Never use gasoline, diesel oil or other inflammable liquids as cleaning agents. Use non-flammable non-toxic proprietary solvents.
- Wear safety goggles with side guards when cleaning parts with compressed air.
- Limit the air pressure to a maximum of **2.1 bar (30.5 psi)**, according to local regulations.



## INTRODUCTION

---

- Do not run the engine in confined spaces without suitable ventilation.
- Do not smoke, use naked flames, or cause sparks in the area when fuel filling or handling highly inflammable liquids.
- Never use naked flames for lighting when working on the machine or checking for leaks.
- All movements must be carried out carefully when working under, on or near the vehicle and wear protective equipment: helmets, goggles and special footwear.
- When carrying out checks with the engine running, request the assistance of an operator in the driver's seat. The operator must maintain visual contact with the service technician at all times.
- If operating outside the workshop, position the vehicle on a flat surface and lock in position. If working on a slope, lock the vehicle in position and move to a flat area as soon as is safely possible.
- Damaged or bent chains or cables are unreliable. Do not use them for lifting or towing. Always use suitable protective gloves when handling chains or cables.
- Chains should always be safely secured. Ensure that fastening device is strong enough to hold the load foreseen. No persons should stop near the fastening point, trailing chains or cables.
- Maintenance and repair operations must be carried out in a CLEAN and DRY area, eliminate any water or oil spillage immediately.
- Do not create piles of oil or grease--soaked rags as they represent a serious fire hazard; store them in a closed metal container.  
Before starting the vehicle or implements, make sure that the driver's seat is locked in position and always check that the area is free of persons or obstacles.
- Empty pockets of all objects that may fall unobserved into the vehicle parts when disassembled.
- In the presence of protruding metal parts, use protective goggles or goggles with side guards, helmets, special footwear and gloves.
- Handle all parts carefully, do not put your hands or fingers between moving parts, wear suitable safety clothing -- safety goggles, gloves and shoes.

## WELDING OPERATIONS

- When welding, use protective safety devices: tinted safety goggles, helmets, special overalls, gloves and footwear. All persons present in the area where welding is taking place must wear tinted goggles.  
**NEVER LOOK AT THE WELDING ARC IF YOUR EYES ARE NOT SUITABLY PROTECTED.**
- Where possible, remove the part or tool that requires arc welding from the tractor.
- Disconnect both battery leads. Isolate the cable ends to avoid contact with each other and the tractor.
- Position the welder ground clamp as near as possible to the area where welding is taking place.
- Remove the electronic control units located on the tractor if welding is to be carried out near these control units.
- Never allow welding cables to lay on, near or across any electrical wiring or electronic component while welding is in progress.
- Metal cables tend to fray with repeated use. Always use suitable protective devices (gloves, goggles, etc.) when handling cables.

## START UP

- Never start the engine in confined spaces that are not equipped with adequate ventilation for exhaust gas extraction.
- Never place the head, body, limbs, feet, hands or fingers near fans or rotating belts.

## ENGINE

- Always loosen the radiator cap slowly before removing it to allow any remaining pressure in the system to be discharged. Coolant should be topped up only when the engine is stopped or idle if hot.
- Never fill up with fuel when the engine is running, especially if hot, in order to prevent the outbreak of fire as a result of fuel spillage
- Never check or adjust fan belt tension when the engine is running.  
Never adjust the fuel injection pump when the vehicle is moving.

- Never lubricate the vehicle when the engine is running.

### **ELECTRICAL SYSTEMS**

- If it is necessary to use auxiliary batteries, remember that both ends of the cables must be connected as follows: (+) with (+) and (-) with (-).
- Avoid short-circuiting the terminals. **GAS RELEASED FROM BATTERIES IS HIGHLY INFLAMMABLE.**
- During charging, leave the battery compartment uncovered to improve ventilation.
- Never check the battery charge using "jumpers" (metal objects placed on the terminals).
- Avoid sparks or flames near the battery zone to prevent explosion hazards.
- Before servicing operations, check for fuel or current leaks. Eliminate any eventual leaks before starting work.
- Never charge batteries in confined spaces. Make sure that there is adequate ventilation in order to prevent accidental explosion hazards as a result of the accumulation of gases released during charging operations.
- Always disconnect the battery before performing any kind of servicing on the electrical system.

### **HYDRAULIC SYSTEMS**

- Some fluid slowly coming out from a very small port can be almost invisible and be strong enough to penetrate the skin. Check for leaks using a piece of cardboard, **NEVER USE HANDS.**
- If any liquid penetrates skin tissue, call for medical aid immediately
- Serious skin infections may result if medical attention is not given.
- Use the specific tools when checking pressure values on the hydraulic system.

### **WHEELS AND TYRES**

- Check that the tyres are correctly inflated at the pressure specified by the manufacturer. Periodically check possible damages to the rims and tyres.
- Stand away from (at the side of) the tire when checking inflation pressure.
- Only check pressure when the vehicle is unloaded and the tires are cold, to avoid incorrect readings as a result of over--pressure.
- Do not re--use parts of recovered wheels as incorrect welding or brazing may heat the material, causing it to weaken and eventually damage or break the wheel.
- Never cut, nor weld a rim with the inflated tyre assembled.
- When removing the wheels, lock both the front and rear vehicle wheels.
- Always position support stands when raising the vehicle, in order to conform to current safety regulations.
- Deflate the tyre before removing any object caught into the tyre tread.
- Never inflate tires using inflammable gases; this could cause an explosion and put operator safety at risk.

### **REMOVAL AND RE-FITTING**

- Lift and handle all heavy parts using suitable lifting equipment and make sure that all slings and hooks are correctly secured.
- Handle all parts carefully during lifting operations, keep an eye on the personnel working near the load to be lifted. Never insert hands or fingers between parts, always wear approved accident prevention clothing (goggles, gloves and work boots).
- Avoid twisting chains or metal cables and always wear safety gloves when handling cables or chains.

---

## Personal safety CAB AIR CONDITIONING SYSTEM

### SAFETY REGULATIONS

- The refrigerant must be handled with great care in order to avoid personal injury; always use safety goggles and gloves.
- Liquid refrigerant can cause freezing of the skin and serious damage to the eyes, sometimes resulting in permanent blindness.
- Keep the refrigerant container away from heat sources. Heat will cause an increase in pressure of the refrigerant and could cause the container to explode.
- If refrigerant comes into contact with a naked flame or a hot metal surface it produces a toxic gas, which is dangerous if inhaled.
- In order to avoid accidents follow the simple precautions described below.
- The operation of emptying and charging the system must be carried out in a well-ventilated area, well away from any naked flames.
- During the charging and emptying operations, take the necessary precautions to protect the face and above all the eyes from accidental contact with refrigerant.
- In the event of an accident, proceed as follows:
  - if refrigerant splashes into the eyes, wash immediately with a few drops of mineral oil, then wash them thoroughly with a solution of boric acid and water (one spoonful of acid in 1/4 cup of water) and seek medical assistance immediately.
  - freezing of the skin caused by contact with liquid refrigerant may be treated by gradually warming the injured area with cold water, followed by the application of a greasy cream. Request medical assistance.
  - the air conditioning system contains a mixture of refrigerant and oil under high pressure; under no circumstances loosen pipe fittings/unions or work on the pipes without having first drained the system.
  - do not loosen or remove the compressor oil level check cap with the system pressurized.
  - do not heat the refrigerant container. If the temperature exceeds **50 °C (122.00 °F)** the pressure will increase very rapidly.
  - keep the air conditioning system away from heat sources to prevent explosions as a result of an increase in pressure in the system piping.
- When transferring refrigerant from one container to another, only use homologated liquid refrigerant containers equipped with safety valves.
- Never fill liquid refrigerant containers over **80 % (80.0 %)** of their maximum capacity.
- Do not modify the settings of safety valves and the control devices.
- Never connect the recovery/recycling and evacuation/charging stations to electrical power outlets with voltages other than those specified; do not leave the stations powered up unless they are to be used immediately.

## Basic instructions

### BATTERY

Before commencing any work on the vehicle, always disconnect and isolate the negative lead from the battery, unless otherwise indicated for a specific operation (for example: an operation to be carried out with the engine running), on completion of which the negative lead should be disconnected before proceeding with the work.

### SHIMMING

At each adjustment, select the shims measuring them one at a time with a micrometer and summing the values obtained: do not measure the complete pack of shims all together or rely on the nominal values indicated on the shims as these could produce incorrect measurements.

### ROTATING SHAFT SEALS

For correct rotating shaft seal installation, proceed as follows:

- before assembly, allow the seal to soak in the oil it will be sealing for at least thirty minutes;
- thoroughly clean the shaft and check that the working surface on the shaft is not damaged;
- position the sealing lip facing the fluid; with hydrodynamic lips, take into consideration the shaft rotation direction and position the grooves so that they will deviate the fluid towards the inner side of the seal;
- coat the sealing lip with a thin layer of lubricant (use oil rather than grease) and fill the gap between the sealing lip and the dust lip on double lip seals with grease;
- insert the seal in its seat and press down using a flat punch; do not tap the seal with a hammer or mallet;
- whilst inserting the seal, check that it is perpendicular to the seat; once settled, make sure that it makes contact with the thrust element, if required;
- to prevent damaging the seal lip on the shaft, position a protective guard during installation operations.

### O--RING SEALS

Lubricate the O--RING seals before inserting them in the seats, this will prevent them from overturning and twisting, which would jeopardise sealing efficiency.

### sealants

Apply one of the following sealing compounds on the mating surfaces marked with an X: **RTV 1473**, **RHODORSIL® CAF 1** or **LOCTITE® PLASTIC GASKET**.

Before applying the sealing compound, prepare the surfaces as follows:

- remove any incrustations using a wire brush;
- thoroughly de--grease the surfaces using one of the following cleaning agents: trichlorethylene, petrol or a water and soda solution.

### BEARINGS

When installing bearings it is advised to:

- heat the bearings to 80 ÷ 90 °C before fitting on the shafts;
- allow the bearings to cool before installing them.

### SPRING PINS

When fitting split socket elastic pins, ensure that the pin notch is positioned in the direction of the force required to stress the pin.

Spiral spring pins do not require special positioning.

## **NOTICES**

Wear limit values indicated for certain parts are recommended, but not binding. The terms “front”, “rear”, “right-hand” and “left-hand” (when referred to different parts) are intended as seen from the driving position with the tractor in the normal direction of movement.

## **MOVING THE TRACTOR WITH THE BATTERY REMOVED**

External power supply cables should only be connected to the respective positive and negative cable terminals, using efficient clamps that guarantee adequate and secure contact. Disconnect all services (lights, windshield wipers, etc.) before starting the vehicle. If the vehicle electrical system requires checking, carry out operations with the power supply connected; Once checking is completed, disconnect all services and switch off the power supply before disconnecting the cables.

---

## **Special tools NOTES FOR EQUIPMENT**

The tools that NEW HOLLAND propose and illustrate in this manual are:

- specifically researched and designed for use with NEW HOLLAND vehicles;
- necessary to make reliable repair;
- accurately built and strictly tested to offer efficient and long--lasting working means.

By using these tools, repair personnel will benefit from:

- operating in optimal technical conditions;
- obtaining the best results;
- saving time and effort;
- working in safe conditions.

## Consumables

|                                     | QUANTITY  | RECOMMENDED NEW HOLLAND PRODUCTS                                    | SPECIFICATION NEW HOLLAND | INTERNATIONAL SPECIFICATION        |
|-------------------------------------|---|---|---------------------------|------------------------------------|
| Cooling system                      | <b>16 l (4.2 US gal)</b><br>Model without cab<br><b>14 l (3.7 US gal)</b> | Water and <b>NEW HOLLAND AMBRA AGRIFLU</b> fluid <b>50 % + 50 %</b> | NH 900 A                  | -                                  |
| Windshield washer reservoir         | <b>2 l (0.5 US gal)</b>   | Water and detergent liquid  | -                         | -                                  |
| Fuel tank                           | <b>115 l (30 US gal)</b>  | Decanted, filtered diesel fuel                                      | -                         | -                                  |
| Engine oil                          | <b>8.5 l (2 US gal)</b>   | <b>NEW HOLLAND AMBRA UNITEK MASTERGOLD SBL CJ-4 SAE 10W-40</b>      | MAT3521                   | API CJ-4<br>ACEA E7/E9             |
| Brake control circuit               | <b>0.7 l (0.18 US gal)</b>  | <b>NEW HOLLAND AMBRA BRAKE LHM</b>                                  | NH 610 A                  | ISO 7308                           |
| Front axle                          | <b>4.5 l (1.2 US gal)</b>   | <b>NEW HOLLAND AMBRA MULTI G™ HYDRAULIC TRANSMISSION OIL</b>        | NH 410 B                  | API GL4<br>ISO 32/46<br>SAE 10W-30 |
| Final drives (each)                 | <b>1.0 l (0.3 US gal)</b>   |   |                           |                                    |
| Transmission/rear axle              |   |   |                           |                                    |
| Mechanical                          | <b>48 l (12.7 US gal)</b>   |   |                           |                                    |
| Hydraulic                           | <b>58 l (15.3 US gal)</b>   |   |                           |                                    |
| Front wheel hubs<br>Grease fittings |   | <b>NEW HOLLAND AMBRA GR-9 MULTI-PURPOSE GREASE</b>                  | NH 710 A                  | NLGI 2                             |
| Air-conditioning refrigerant        | <b>650 g (23 oz)</b>  | -   | -                         | R134                               |
| Air-conditioning compressor oil     | <b>0.185 l (0.05 US gal)</b>  | -   | -                         | SP10                               |

## Part identification

Use solely genuine parts, which guarantee the same quality, duration and safety as the original parts as they are identical to the ones fitted during production.  
Only genuine parts can offer this guarantee.

When ordering spare parts, always provide the following information:

- tractor model (commercial name) and frame number;
- engine type and number;
- part number of the ordered part, which can be found in the “Microfiches” or the “Spare Parts Catalogue”, used for order processing.







## SERVICE MANUAL

### Engine

**T4.105 less cab, with mechanical or power shuttle transmission [ZxJT0xxxx], T4.105 with cab, with mechanical or power shuttle transmission [ZxJT0xxxx], T4.105 with cab, with hi-lo transmission [ZxJT0xxxx], T4.105 with cab, with hi-lo transmission, with Supersteer™ front axle [ZxJT0xxxx], T4.105 less cab, with hi-lo transmission [ZxJT0xxxx], T4.115 less cab, with mechanical or power shuttle transmission [ZxJT0xxxx], T4.115 with cab, with mechanical or power shuttle transmission [ZxJT0xxxx], T4.115 less cab, with hi-lo transmission [ZxJT0xxxx], T4.115 with cab, with hi-lo transmission [ZxJT0xxxx], T4.115 with cab, with hi-lo transmission, with Supersteer™ front axle [ZxJT0xxxx], T4.75 less cab, with mechanical or power shuttle transmission [ZxJT0xxxx], T4.75 with cab, with mechanical or power shuttle transmission [ZxJT0xxxx], T4.75 with cab, with hi-lo transmission [ZxJT0xxxx], T4.75 with cab, with hi-lo transmission, with Supersteer™ front axle [ZxJT0xxxx], T4.75 less cab, with hi-lo transmission [ZxJT0xxxx], T4.85 less cab, with mechanical or power shuttle transmission [ZxJT0xxxx], T4.85 with cab, with mechanical or power shuttle transmission [ZxJT0xxxx], T4.85 with cab, with hi-lo transmission [ZxJT0xxxx], T4.85 with cab, with hi-lo transmission, with Supersteer™ front axle [ZxJT0xxxx], T4.85 less cab, with hi-lo transmission [ZxJT0xxxx], T4.95 less cab, with mechanical or power shuttle transmission [ZxJT0xxxx], T4.95 with cab, with mechanical or power shuttle transmission [ZxJT0xxxx], T4.95 with cab, with hi-lo transmission [ZxJT0xxxx], T4.95 with cab, with hi-lo transmission, with Supersteer™ front axle [ZxJT0xxxx], T4.95 less cab, with hi-lo transmission [ZxJT0xxxx]**

# Contents

---

## Engine - 10

|  |      |
|--|------|
| [10.001] Engine and crankcase .....  | 10.1 |
| [10.216] Fuel tanks .....  | 10.2 |
| [10.501] Exhaust Gas Recirculation (EGR) - Diesel Particulate Filter (DPF) exhaust treatment | 10.3 |
| [10.414] Fan and drive .....   | 10.4 |



## Engine - 10

### Engine and crankcase - 001

**T4.105 less cab, with mechanical or power shuttle transmission [ZxJT0xxxx], T4.105 with cab, with mechanical or power shuttle transmission [ZxJT0xxxx], T4.105 with cab, with hi-lo transmission [ZxJT0xxxx], T4.105 with cab, with hi-lo transmission, with Supersteer™ front axle [ZxJT0xxxx], T4.105 less cab, with hi-lo transmission [ZxJT0xxxx], T4.115 less cab, with mechanical or power shuttle transmission [ZxJT0xxxx], T4.115 with cab, with mechanical or power shuttle transmission [ZxJT0xxxx], T4.115 less cab, with hi-lo transmission [ZxJT0xxxx], T4.115 with cab, with hi-lo transmission [ZxJT0xxxx], T4.115 with cab, with hi-lo transmission, with Supersteer™ front axle [ZxJT0xxxx], T4.75 less cab, with mechanical or power shuttle transmission [ZxJT0xxxx], T4.75 with cab, with mechanical or power shuttle transmission [ZxJT0xxxx], T4.75 with cab, with hi-lo transmission [ZxJT0xxxx], T4.75 with cab, with hi-lo transmission, with Supersteer™ front axle [ZxJT0xxxx], T4.75 less cab, with hi-lo transmission [ZxJT0xxxx], T4.85 less cab, with mechanical or power shuttle transmission [ZxJT0xxxx], T4.85 with cab, with mechanical or power shuttle transmission [ZxJT0xxxx], T4.85**



**with cab, with hi-lo transmission [ZxJT0xxxx], T4.85 with cab, with hi-lo transmission, with Supersteer™ front axle [ZxJT0xxxx], T4.85 less cab, with hi-lo transmission [ZxJT0xxxx], T4.95 less cab, with mechanical or power shuttle transmission [ZxJT0xxxx], T4.95 with cab, with mechanical or power shuttle transmission [ZxJT0xxxx], T4.95 with cab, with hi-lo transmission [ZxJT0xxxx], T4.95 with cab, with hi-lo transmission, with Supersteer™ front axle [ZxJT0xxxx], T4.95 less cab, with hi-lo transmission [ZxJT0xxxx]**



# Contents

---

## Engine - 10

### Engine and crankcase - 001

#### SERVICE

##### Engine

|                   |    |
|-------------------|----|
| Remove (*) .....  | 3  |
| Remove (*) .....  | 13 |
| Install (*) ..... | 23 |
| Install (*) ..... | 33 |

(\*) See content for specific models

## Engine - Remove

|  |  |
|--|--|
| T4.105 with cab, with mechanical or power shuttle transmission [ZxJT0xxxx] |  |
| T4.105 less cab, with mechanical or power shuttle transmission [ZxJT0xxxx] |  |
| T4.115 with cab, with mechanical or power shuttle transmission [ZxJT0xxxx] |  |
| T4.115 less cab, with mechanical or power shuttle transmission [ZxJT0xxxx] |  |
| T4.75 with cab, with mechanical or power shuttle transmission [ZxJT0xxxx]  |  |
| T4.75 less cab, with mechanical or power shuttle transmission [ZxJT0xxxx]  |  |
| T4.85 with cab, with mechanical or power shuttle transmission [ZxJT0xxxx]  |  |
| T4.85 less cab, with mechanical or power shuttle transmission [ZxJT0xxxx]  |  |
| T4.95 with cab, with mechanical or power shuttle transmission [ZxJT0xxxx]  |  |
| T4.95 less cab, with mechanical or power shuttle transmission [ZxJT0xxxx]  |  |

1. Remove the engine hood (1), as indicated in **Hood - Remove (90.100)**.
2. Remove the battery, as described in **Battery - Remove (55.302)**.
3. Remove the tank, as described in **Fuel tank - Remove (10.216)**.
4. Loosen the retaining bolts (1). Remove the front wheel fenders (2) (if any). Do this on both sides.

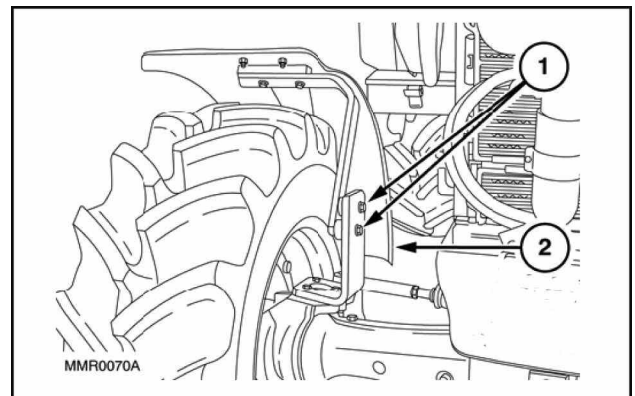

WLAPL4S10C104A 1

5. Recover the refrigerant from the system via the fittings (1) and (2) using the specific tool **380000315**. Detach the two lines by disconnecting any support straps.

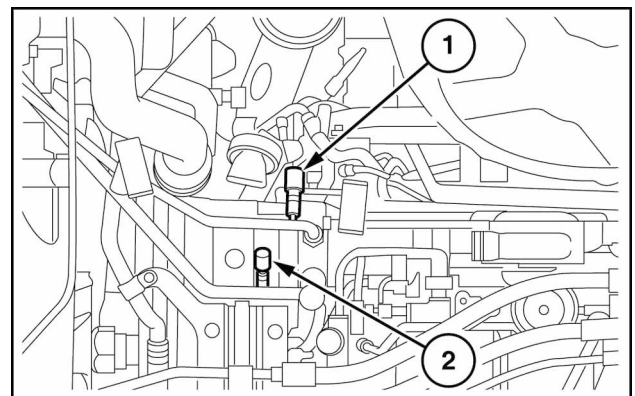

WLAPL4S10C106AA 2

6. Then detach the lower pipe (3) on the condenser (1). Free the pipe from any straps or clamps. Disconnect the sensor (2). Place the pipe on the cab.

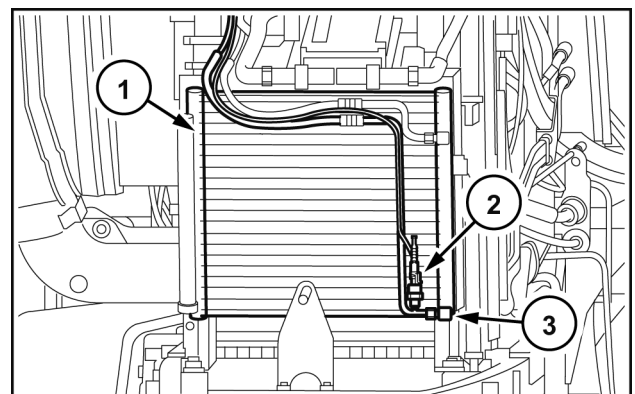

WLAPL4S10C107A 3



7. Raise the rear of the tractor with a hydraulic jack. Place a mechanical jack stand under the reduction gear case. Use a pneumatic gun to remove the retaining nuts of the left-hand rear wheel. Then remove the wheel.

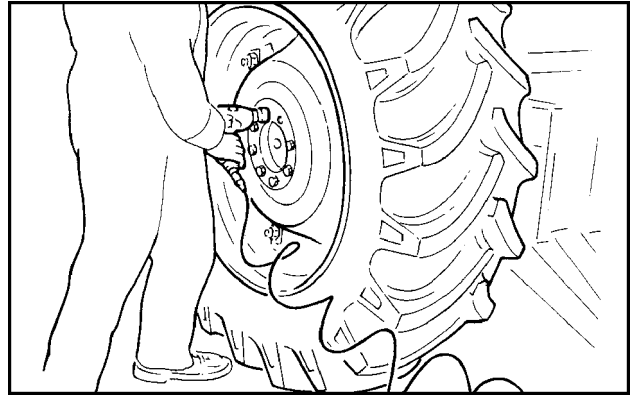

WLAPL4S10C110A 4

8. Unscrew the front, central, and rear retaining bolts on the guard of the front axle control shaft. Then remove the guard (1).

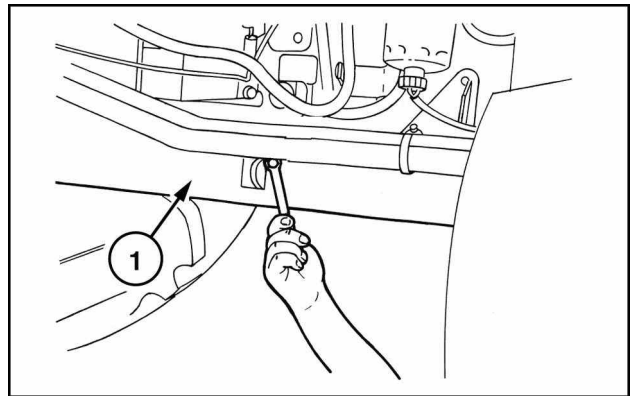

WLAPL4S10C112AA 5

9. Remove the circlip (2) and move the front sleeve (1) in the direction indicated by the arrow until it is released from the groove on the front axle.

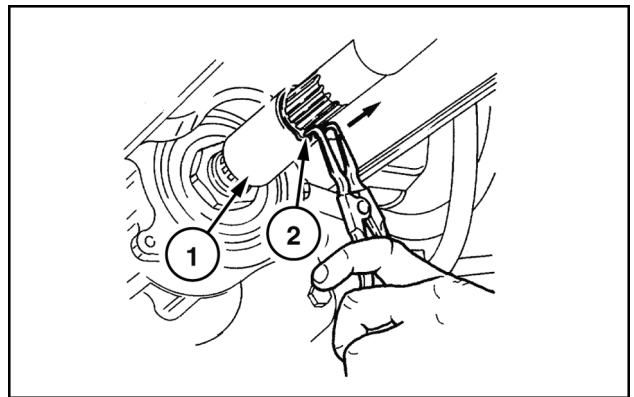

WLAPL4S10C113AA 6

10. Remove the bolts that secure the central support (1) of the drive shaft. Remove the shaft complete with the support. Also remove the shim that adjusts the clearance of the shaft on the back.

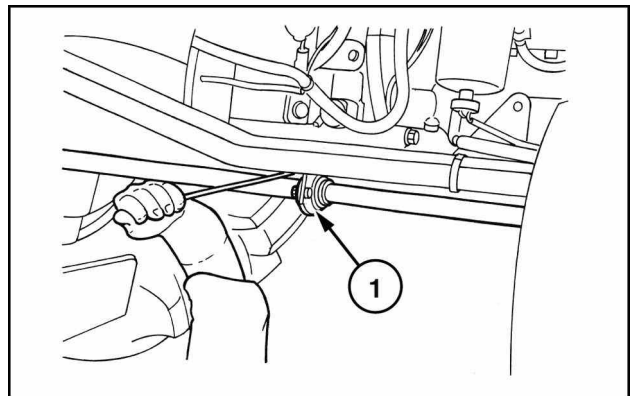

WLAPL4S10C115AA 7

11. Loosen the union of the radiator coolant return line of the cab heater. Drain and collect the engine coolant.

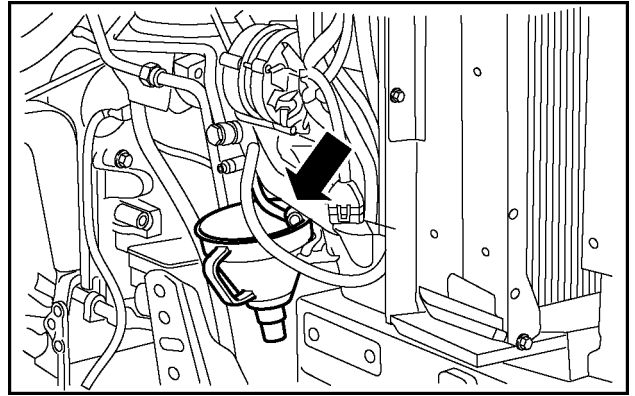

WLAPL4S10C116A 8

12. Place a suitable container under the drain plug (1) for the gearbox-transmission oil. Loosen the plug. Drain the oil.

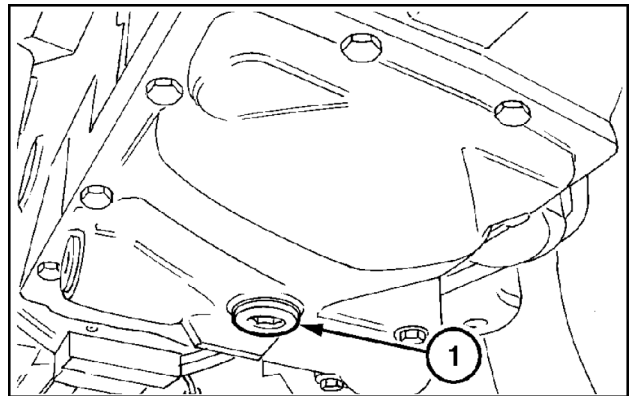

MOIL13TR00197AA 9

13. Remove the brakes reservoir heat shield (1).

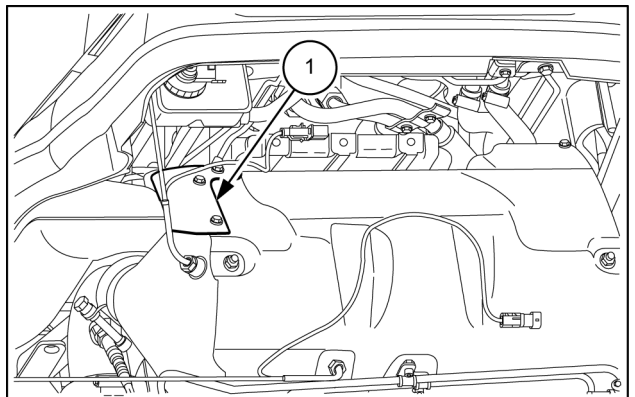

MOIL12APL98 10

14. Loosen the fixing clamp (1) to the filter DPF and the support clamp (2). Remove the exhaust pipe (3).

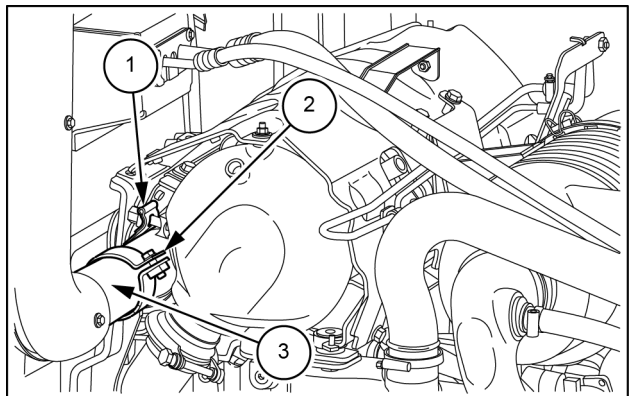

MOIL13TR01798AA 11

15. Loosen the fixing clamps (1). Extract the tubing from the turbine to the radiator intercooler (2). Perform the same operation for the tubing from the radiator intercooler to the engine (3).

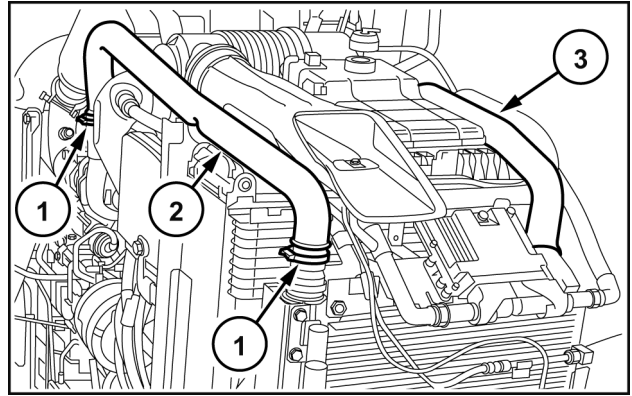

WLAPL4S10C119A 12

16. Loosen the clamp (2) that fastens the air intake duct to the turbine. Then free the air cleaner (4) together with the support bracket (3) from the screws that secure it. Disconnect the oil vapor duct (1) on the right-hand side of the engine.

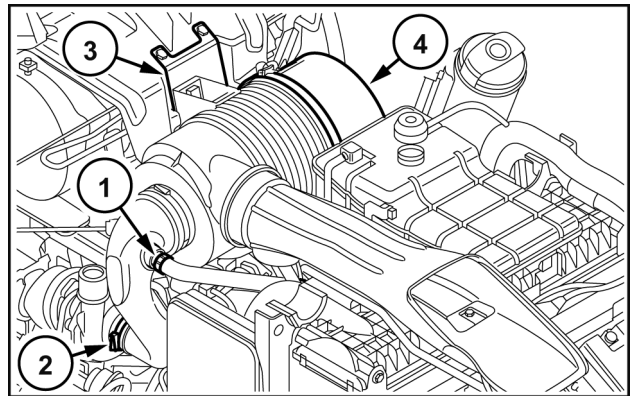

WLAPL4S10C120A 13

17. Free the air cleaner bracket – hood support (1) from the fixing screws and remove it.

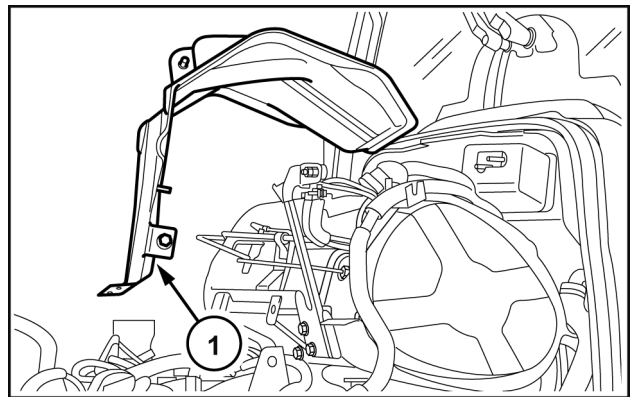

WLAPL4S10C121A 14

**ATTENTION:** The filter outlet union DPF (1) at its terminal (2) has a decoupler that responds to temperature variations by changing length.

A small misalignment of the axis of the decoupler with respect to the axis of the turbine outlet (3) would produce an adjustment that would no longer be lengthwise, in line with the direction of the tractor, but abnormal transversal adjustment that would impair its durability.

18. Disconnect all of the filter sensors. Loosen the clamp (4). Remove the entire filter together with the sensors, pressure sensing tubes, lambda probe, and heat shrouds by undoing the four screws (5) that secure it on the bottom cradle.

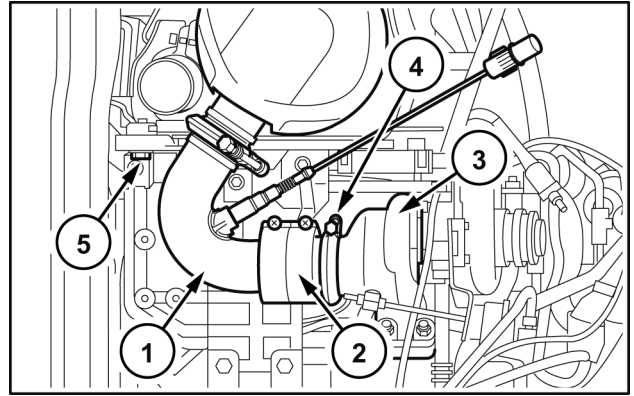

WLAPL4S10C122A 15

**ATTENTION:** Only if you have to work on the parts underneath the DPF filter support, it is advisable to remove the support.

The upper part (1) and the right-hand part (2) should be removed as a block, when possible, by removing the fixing screws (3) to the right-hand side of the engine. (These screws work on a vertical slot that allows the support (2) to take on various height positions). Before removal, take some references on the position of the unit on the engine so that, during re-assembly, it is possible to restore it to the exact position in which it was originally found.

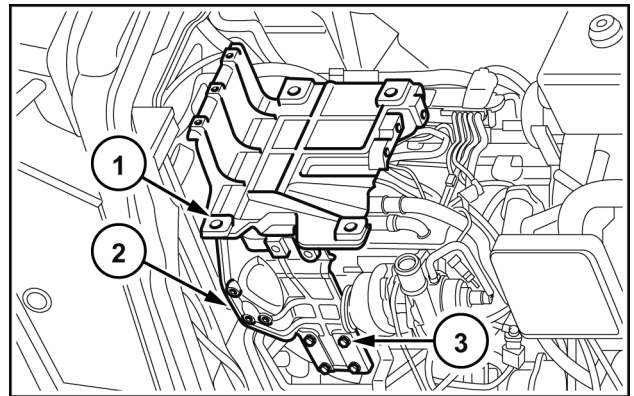

WLAPL4S10C123A 16

19. To remove the rear shield, loosen the two upper screws that fasten the support (4) to the support (1). To remove the left-hand support (5), loosen the two upper screws, the respective centring bushings that secure the left-hand bracket to the support (1). As regards removing the support (1) and (2), there are no special instructions to follow.

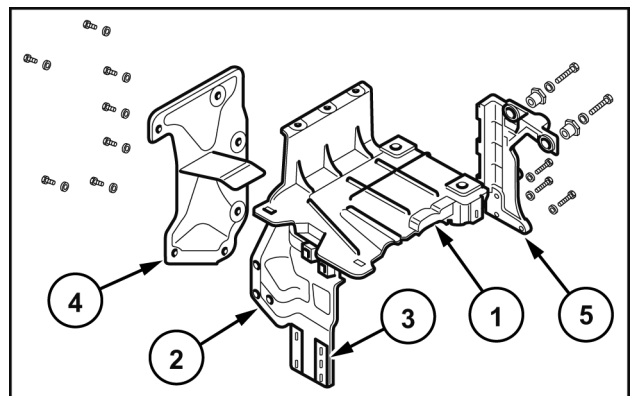

WLAPL4S10C124A 17

20. Detach the steering lines **(1)** and **(2)** and the tube supplying oil to the control valve **(3)**. Remove the fixings of the bracket **(4)** from the engine.

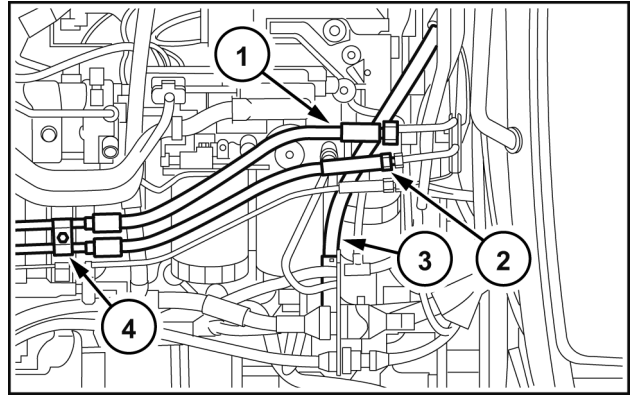

WLAPL4S10C125A 18

21. Detach the exhaust pipe of the power steering control valve on the gearbox control valve **(2)**. On the same filter, detach the gearbox control valve supply pipe **(1)**. Subsequently remove the filter together with the support **(3)**.

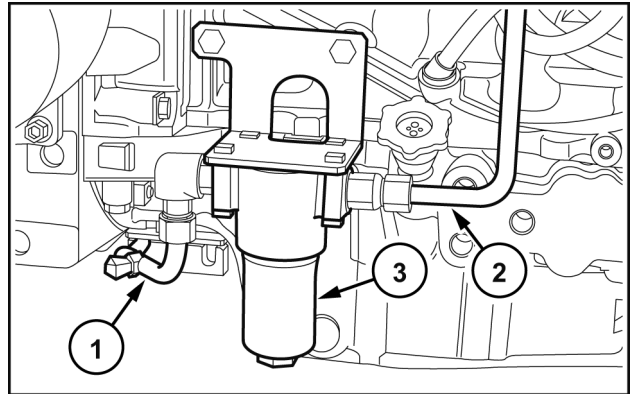

WLAPL4S10C126A 19

22. Detach the oil filter inlet pipe from the transmission **(2)**.  
 23. Detach the supply pipe **(1)** from the mid-mount remote valves.

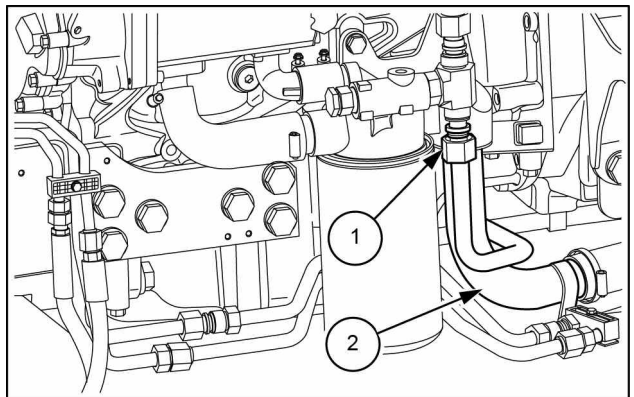

MOIL13TR01799AA 20

24. Detach the pipes **(2)** of the heat exchanger and, if applicable, of the front braking assembly **(1)**.  
 25. Free the pipes that were previously detached from the supports, brackets, and clamps secured to the engine. Also do the same thing for the pipes directed to the cylinder **(3)**.

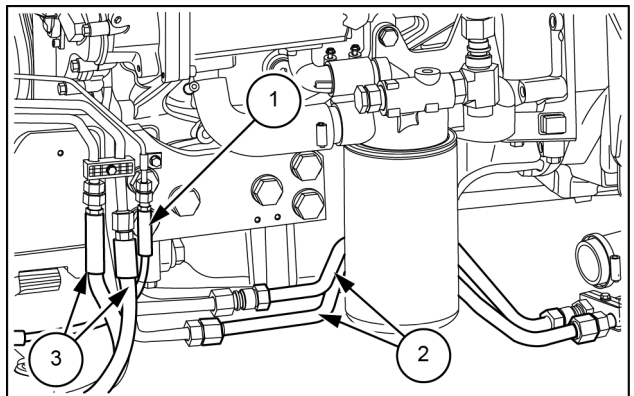

MOIL13TR01800AA 21

26. On the right-hand side, detach the cab heating pipes (1), the pipe inserted on the engine sleeve (2) coming from the expansion tank. Then loosen the clamps. Detach from the engine the lower (3) and upper rubber sleeves of the radiator-engine connection.

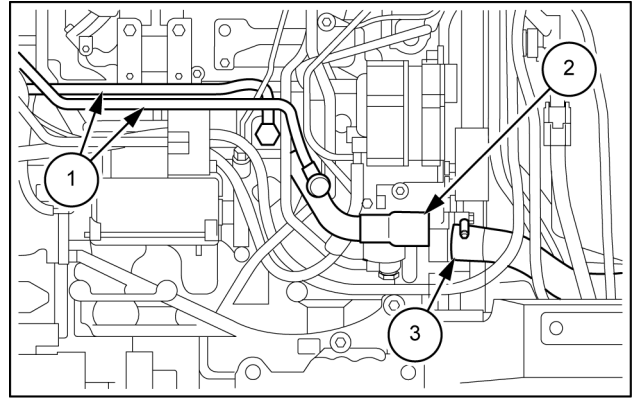

MOIL13TR01739AB 22

27. On the right-hand side, remove the shroud (1) on the starter motor (2). Disconnect the starting cable, the battery cut-off switch, and the cable that joins it to the alternator. Also disconnect the alternator and the battery positive. Free all of the wire harnesses detached from the various clamps.
28. Detach the mounting bolt (3). Then remove the ground cable of the engine and battery system. Remove the other mounting bolts of the motor and remove it.

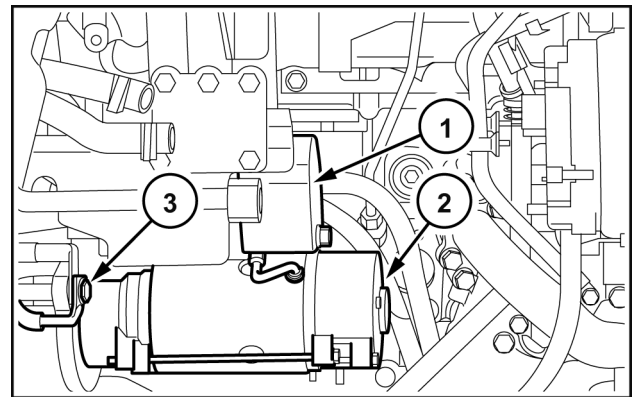

WLAPL4S10C135A 23

29. On the cable (1) of the FTP cable-engine interface, detach all of the connections (2). Leave only those connections on the maxi fuse case and on the glow plug controller. Then, after cutting the clamps, pick up the cable on the front, near the controller (5).
30. Starting from the connector on the controller (4), on the main engine cable (3) disconnect the connectors from the maxi fuse box and from the various switches and sensors located on the engine. After freeing the connector from the clamps, move the connector onto the back, at the height of the right-hand steps.

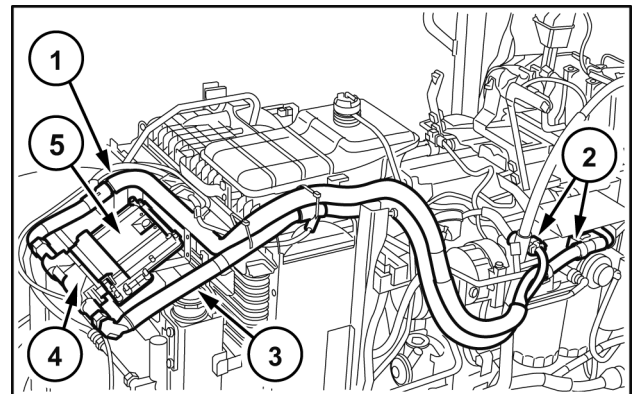

WLAPL4S10C137A 24

31. On the left-hand side, disconnect the connector of the power cable of the cab (1). Free the connector from the clamps. Move the connector onto the maxi fuse box.
32. Detach the bracket (2) supporting the cab connectors, cab power, and cup filter (3). Disconnect the pipe that joins the latter to the mechanical priming pump on the sediment filter.

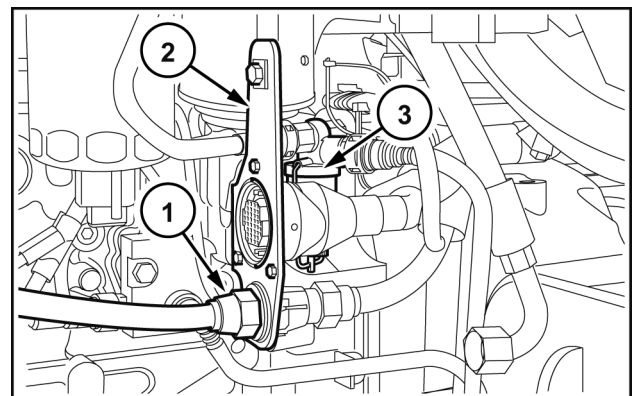

WLAPL4S10C139A 25

33. Hook the rear part of the engine to a hoist using chains or ropes for lifting. (Apply two eyebolts, one to the right-hand side and one to the left-hand side, on the upper part of the flange containing the flywheel.) Position a fixed jack stand (2) under the clutch case (1) near the engine attachment flanging. Apply the hand brake.

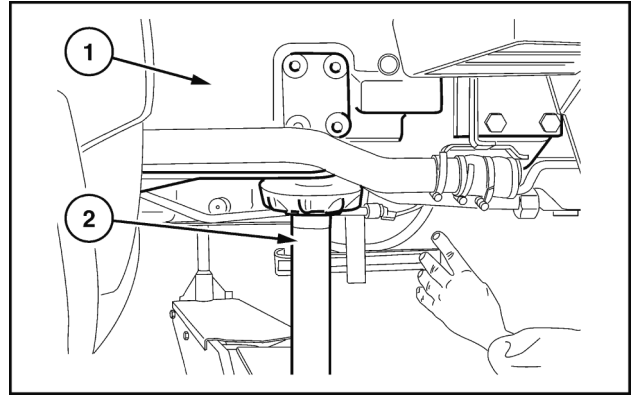

WLAPL4S10C129A 26

34. Position the movable tool for dismantling tractors (2) 380000405 with the bracket and adapter plate under the engine. Place a wooden block (1) between the points of contact between the tool and the engine. Wedge the axle to prevent swinging.

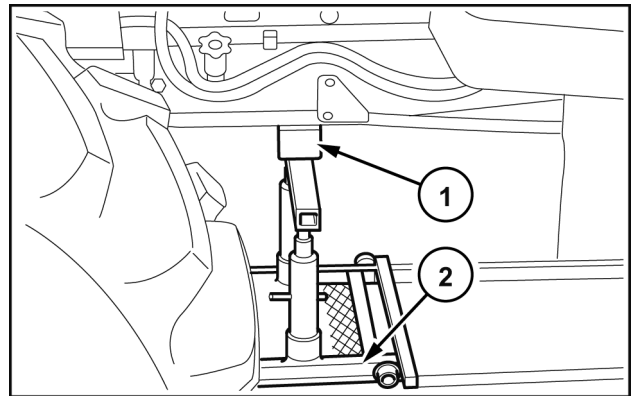

WLAPL4S10C140A 27

35. Remove the retaining bolts (1) between the engine and the transmission.

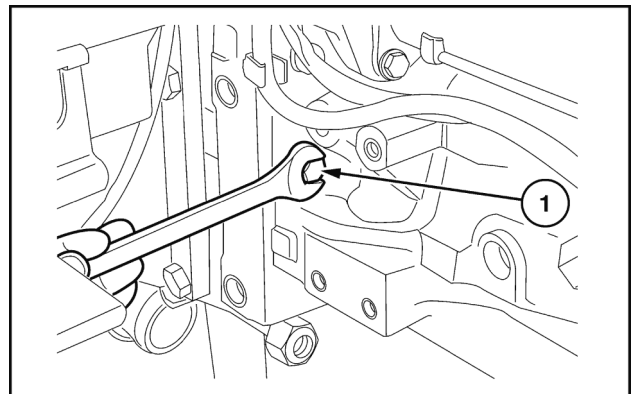

WLAPL4S10C130A 28

36. Separate the engine (1) from the transmission with the appropriate tool 380000405 (2).

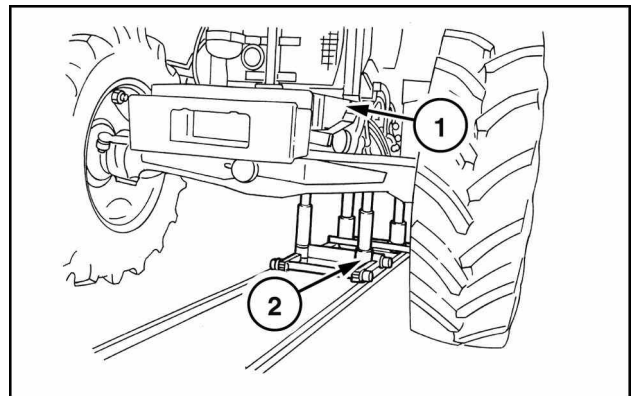

WLAPL4S10C131AA 29

37. Insert a fixed jack stand (1) under the ballast support. Chock the front wheels with wooden wedges (2).

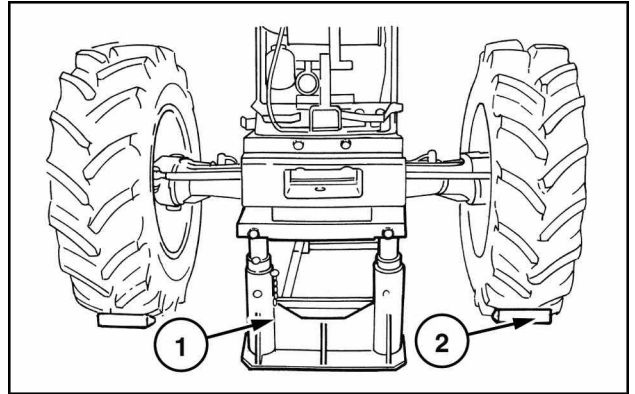

WLAPL4S10C132AA 30

38. Position a fixed jack stand (3) under the support of the groove (1) of the drive of the front axle, inserting a wooden plug (2) between parts (3) and (1).

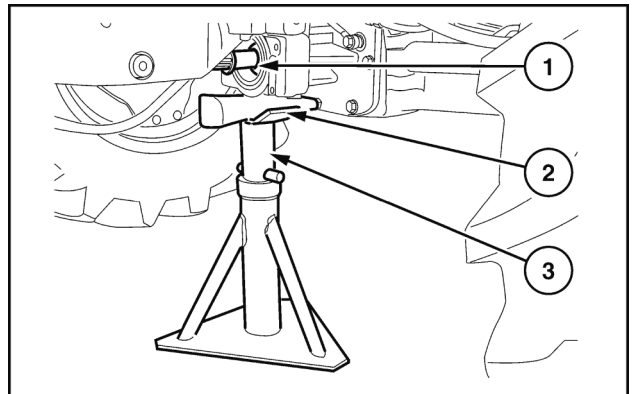

WLAPL4S10C133A 31

39. Position a jack stand under the rear of the engine so as to be able to safely release the hoist with the coupling device. Add a rope or chain (1) also on the front of the engine. Take up the slack with the lifting device, keeping the engine balanced.

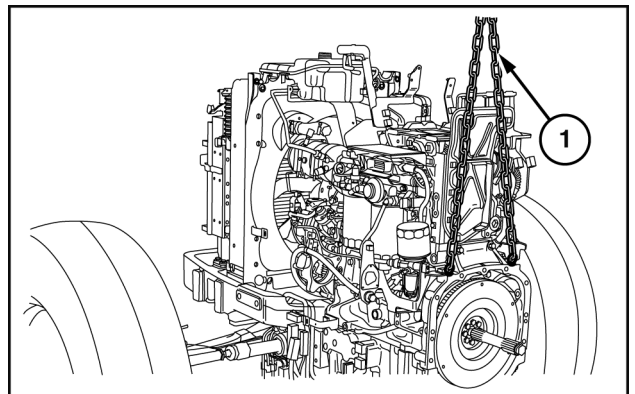

WLAPL4S10C136A 32

40. Remove the bolts (2) fastening the front axle support (1) to the engine.

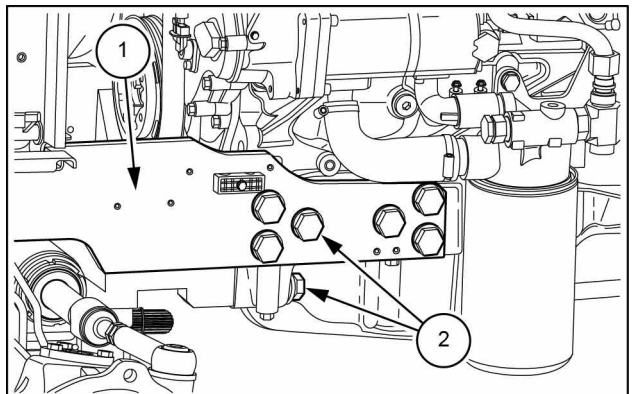

MOIL13TR01801AA 33



41. Check that there are no brackets between the engine and the cooling assembly. Detach the engine (2) from the front axle (3). Try to avoid incorrect maneuvers with the hoist in order to not damage the fins of the radiator on the axle with the engine fan (1). Rest the engine (2) on a support.

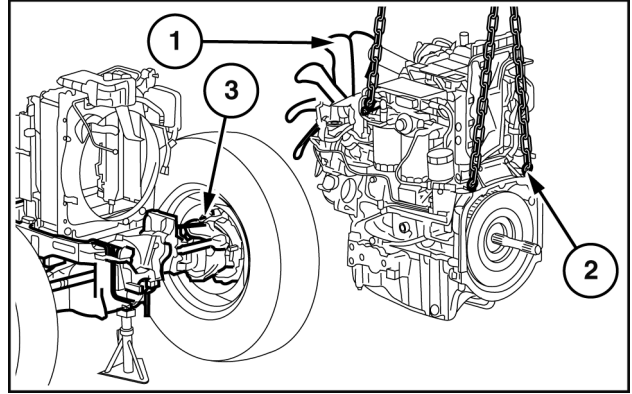

WLAPL4S10C138A 34

42. Remove the cooling fan (1).

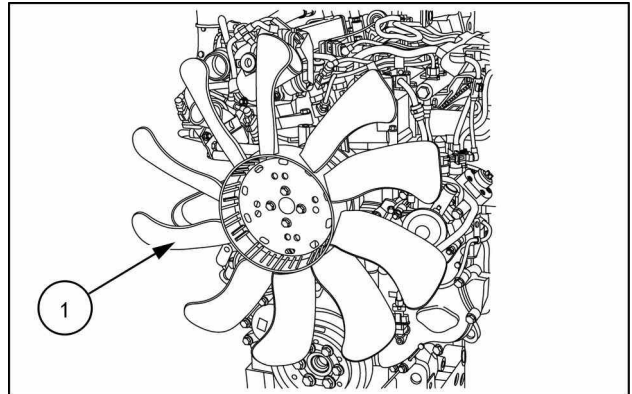

MOIL14UTL0038AA 35

43. Loosen the compressor fixing screws (4). Remove the belt (5). Then remove the compressor.
44. Completely loosen the belt tensioner (2). Remove the flexible belt (3). Then remove the alternator (1).

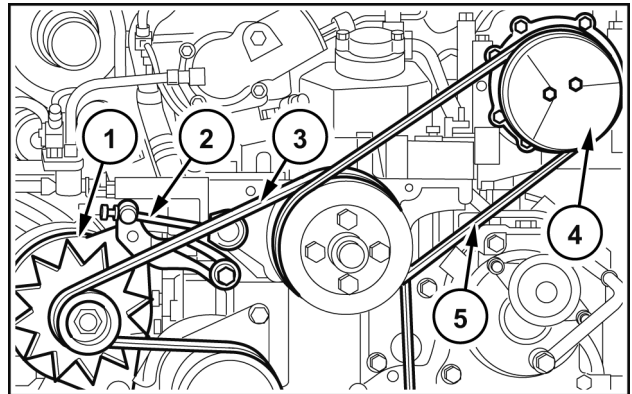

WLAPL4S10C145A 36

## Engine - Remove

|   |  |
|---|--|
| T4.105 with cab, with hi-lo transmission [ZxJT0xxxx]                              |  |
| T4.105 with cab, with hi-lo transmission, with Supersteer™ front axle [ZxJT0xxxx] |  |
| T4.105 less cab, with hi-lo transmission [ZxJT0xxxx]                              |  |
| T4.115 with cab, with hi-lo transmission [ZxJT0xxxx]                              |  |
| T4.115 less cab, with hi-lo transmission [ZxJT0xxxx]                              |  |
| T4.75 with cab, with hi-lo transmission [ZxJT0xxxx]                               |  |
| T4.75 with cab, with hi-lo transmission, with Supersteer™ front axle [ZxJT0xxxx]  |  |
| T4.75 less cab, with hi-lo transmission [ZxJT0xxxx]                               |  |
| T4.85 with cab, with hi-lo transmission [ZxJT0xxxx]                               |  |
| T4.85 with cab, with hi-lo transmission, with Supersteer™ front axle [ZxJT0xxxx]  |  |
| T4.85 less cab, with hi-lo transmission [ZxJT0xxxx]                               |  |
| T4.95 with cab, with hi-lo transmission [ZxJT0xxxx]                               |  |
| T4.95 with cab, with hi-lo transmission, with Supersteer™ front axle [ZxJT0xxxx]  |  |
| T4.95 less cab, with hi-lo transmission [ZxJT0xxxx]                               |  |

1. Remove the engine hood (1), as indicated in **Hood - Remove (90.100)**.
2. Remove the battery, as described in **Battery - Remove (55.302)**.
3. Remove the tank, as described in **Fuel tank - Remove (10.216)**.
4. Loosen the retaining bolts (1). Remove the front wheel fenders (2) (if any). Do this on both sides.

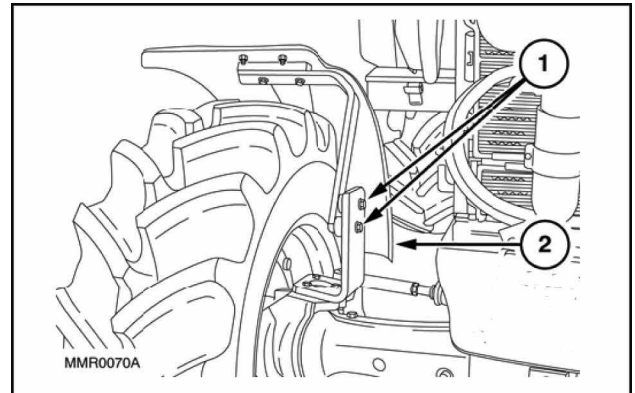

WLAPL4S10C104A 1

5. Recover the refrigerant from the system via the fittings (1) and (2) using the specific tool **380000315**. Detach the two lines by disconnecting any support straps.

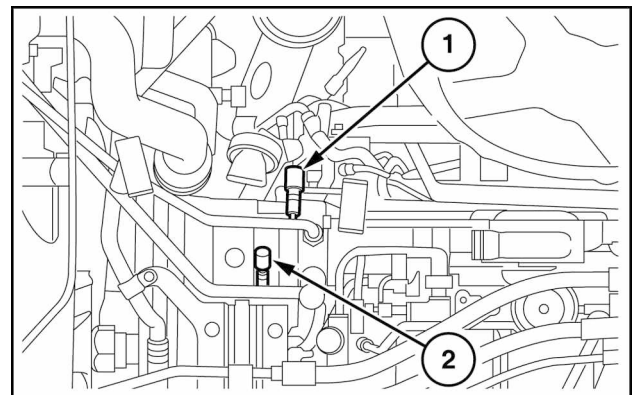

WLAPL4S10C106AA 2

6. Then detach the lower pipe (3) on the condenser (1). Free the pipe from any straps or clamps. Disconnect the sensor (2) and take it to the cab.

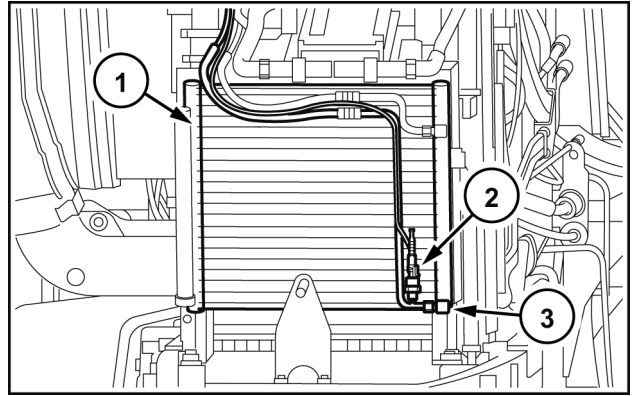

WLAPL4S10C107A 3

7. Raise the rear of the tractor with a hydraulic jack. Place a mechanical jack stand under the reduction gear case. Use a pneumatic gun to remove the retaining nuts of the left-hand rear wheel. Then remove the wheel.

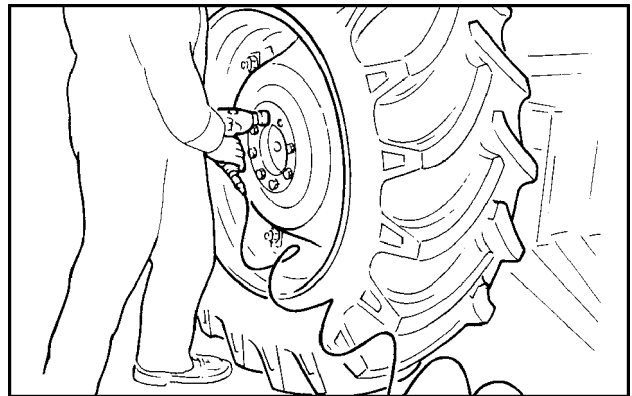

WLAPL4S10C110A 4

8. Unscrew the front, central, and rear retaining bolts on the guard of the front axle control shaft. Then remove the guard (1).

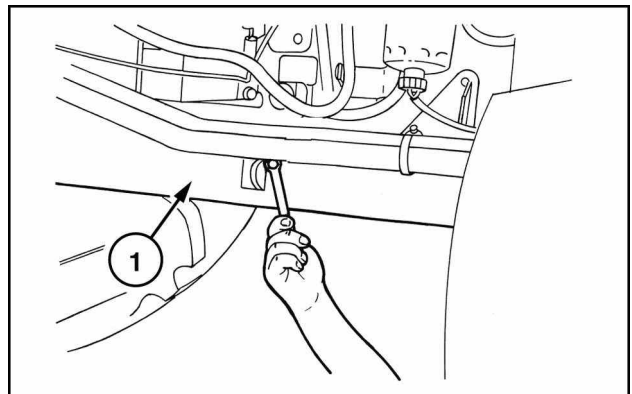

WLAPL4S10C112AA 5

9. Remove the circlip (2) and move the front sleeve (1) in the direction indicated by the arrow until it is released from the groove on the front axle.

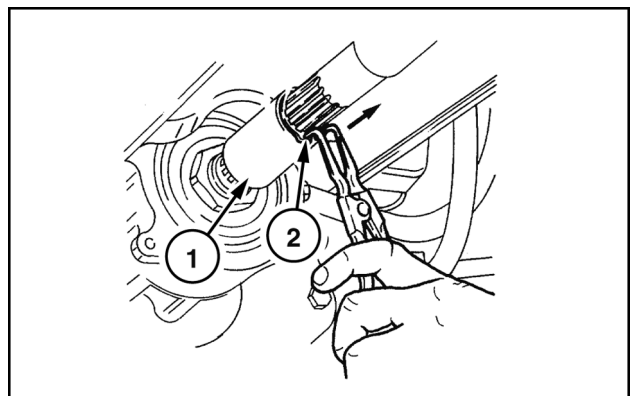

WLAPL4S10C113AA 6

10. Remove the bolts that secure the central support **(1)** of the drive shaft. Remove the shaft complete with the support. Also remove the shim that adjusts the clearance of the shaft on the back.

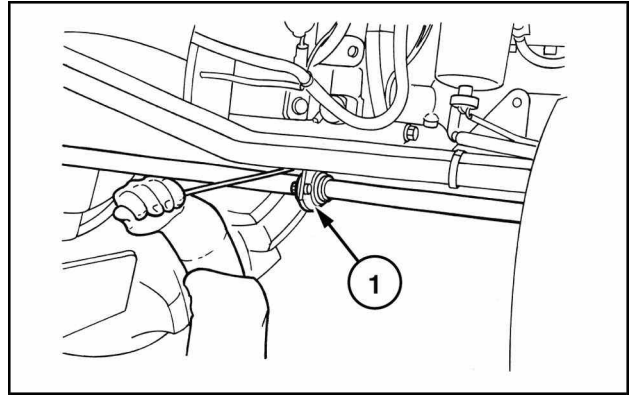

WLAPL4S10C115AA 7

11. Loosen the union of the radiator coolant return line of the cab heater. Drain and collect the engine coolant.

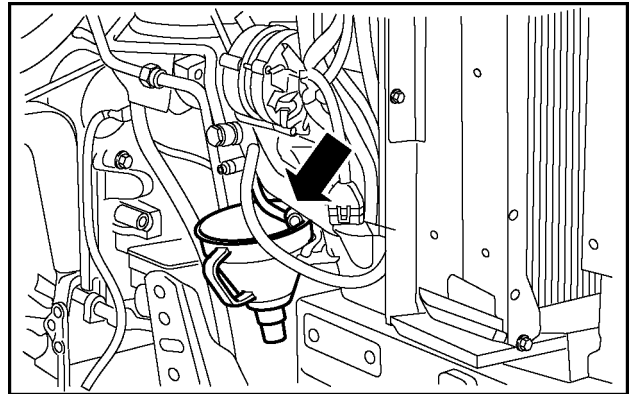

WLAPL4S10C116A 8

12. Place a suitable container under the drain plug **(1)** for the gearbox-transmission oil. Loosen the plug. Drain the oil.

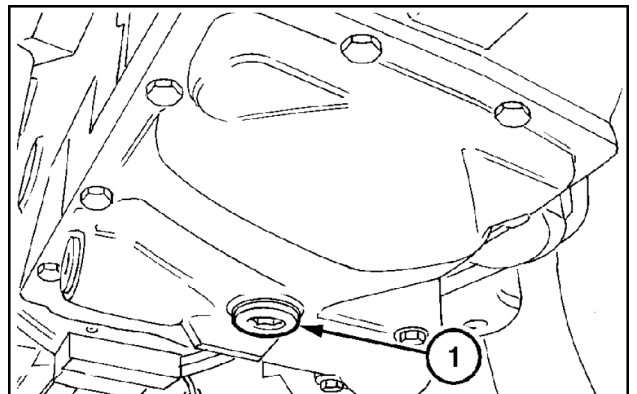

MOIL13TR00197AA 9

13. Remove the brakes reservoir heat shield **(1)**.

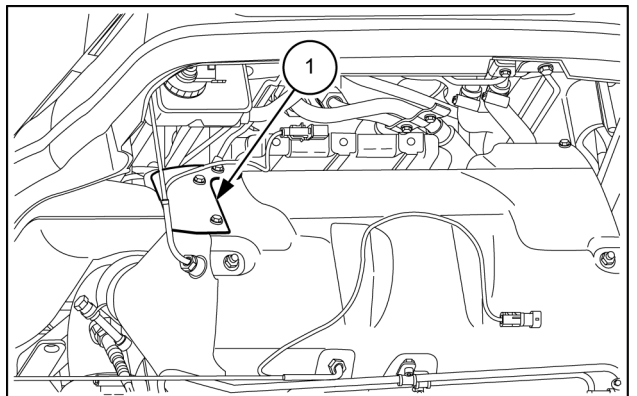

MOIL12APL98 10

14. Loosen the fixing clamp (1) to the filter DPF and the support clamp (2). Remove the exhaust pipe (3).

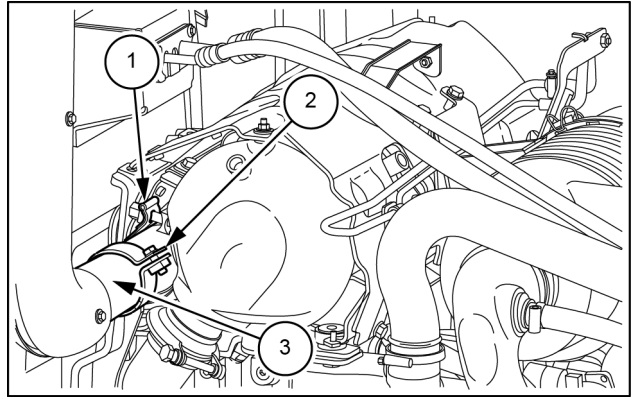

MOIL13TR01798AA 11

15. Loosen the fixing clamps (1). Extract the tubing from the turbine to the radiator intercooler (2). Perform the same operation for the tubing from the radiator intercooler to the engine (3).

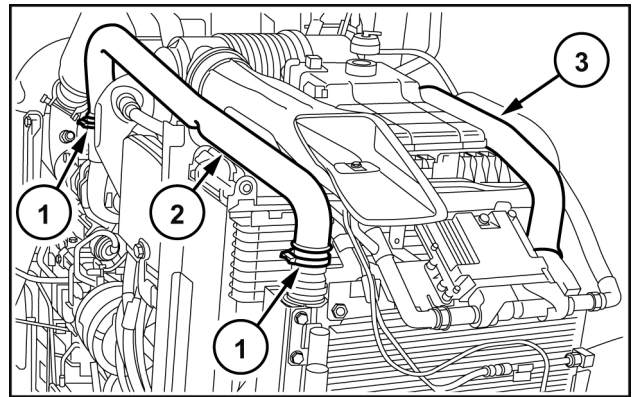

WLAPL4S10C119A 12

16. Loosen the clamp (2) that fastens the air intake duct to the turbine. Then free the air cleaner (4) together with the support bracket (3) from the screws that secure it. Disconnect the oil vapor duct (1) on the right-hand side of the engine.

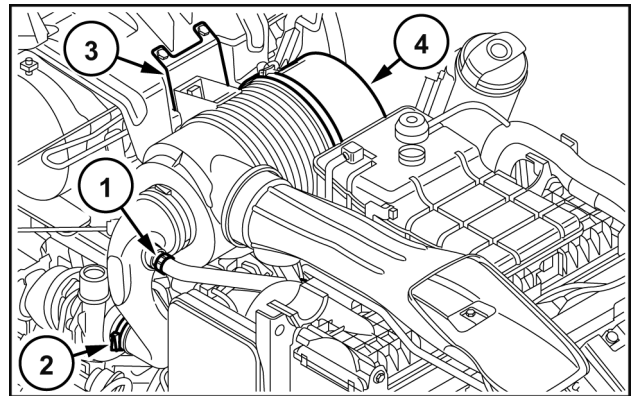

WLAPL4S10C120A 13

17. Free the air cleaner bracket – hood support (1) from the fixing screws and remove it.

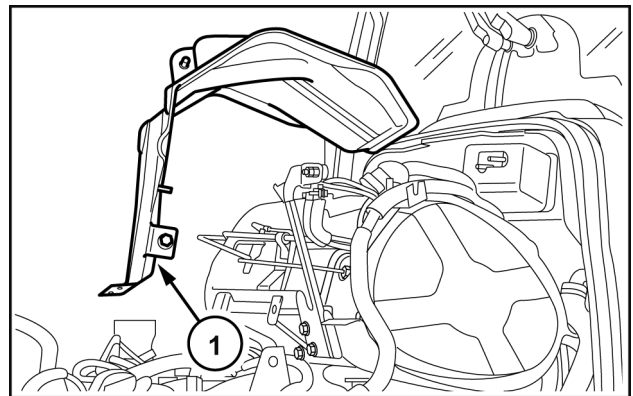

WLAPL4S10C121A 14

**ATTENTION:** The filter outlet union DPF (1) at its terminal (2) has a decoupler that responds to temperature variations by changing length.

A small misalignment of the axis of the decoupler with respect to the axis of the turbine outlet (3) would produce an adjustment that would no longer be lengthwise, in line with the direction of the tractor, but abnormal transversal adjustment that would impair its durability.

18. Disconnect all of the filter sensors. Loosen the clamp (4). Remove the entire filter together with the sensors, pressure sensing tubes, lambda probe, and heat shrouds by undoing the four screws (5) that secure it on the bottom cradle.

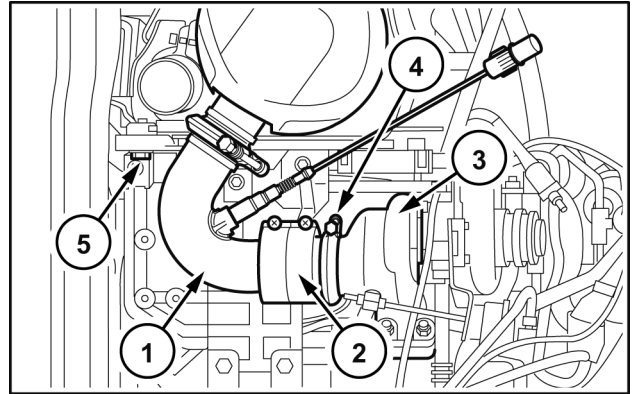

WLAPL4S10C122A 15

**ATTENTION:** Only if you have to work on the parts underneath the DPF filter support, it is advisable to remove the support.

The upper part (1) and the right-hand part (2) should be removed as a block, when possible, by removing the fixing screws (3) to the right-hand side of the engine. (These screws work on a vertical slot that allows the support (2) to take on various height positions). Before removal, take some references on the position of the unit on the engine so that, during re-assembly, it is possible to restore it to the exact position in which it was originally found.

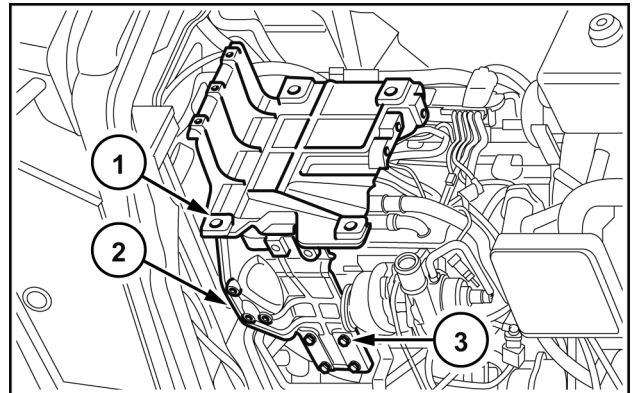

WLAPL4S10C123A 16

19. To remove the rear shield, loosen the two upper screws that fasten the support (4) to the support (1). To remove the left-hand support (5), loosen the two upper screws, the respective centring bushings that secure the left-hand bracket to the support (1). As regards removing the support (1) and (2), there are no special instructions to follow.

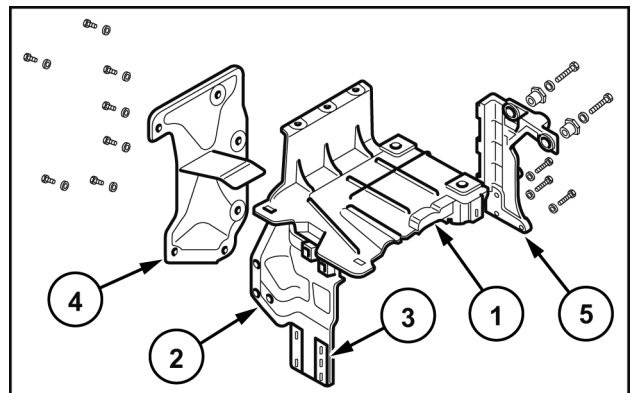

WLAPL4S10C124A 17

20. Detach the steering lines (1) and (2) and the tube supplying oil to the control valve (3). Remove the fixings of the bracket (4) from the engine.

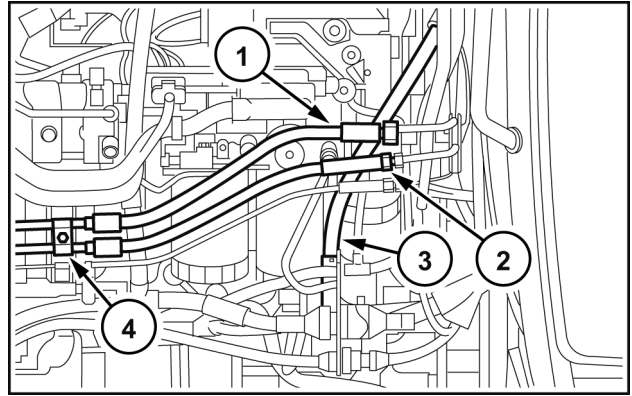

WLAPL4S10C125A 18

21. Detach the exhaust pipe of the power steering control valve on the gearbox control valve (2). On the same filter, detach the gearbox control valve supply pipe (1). Subsequently remove the filter together with the support (3).

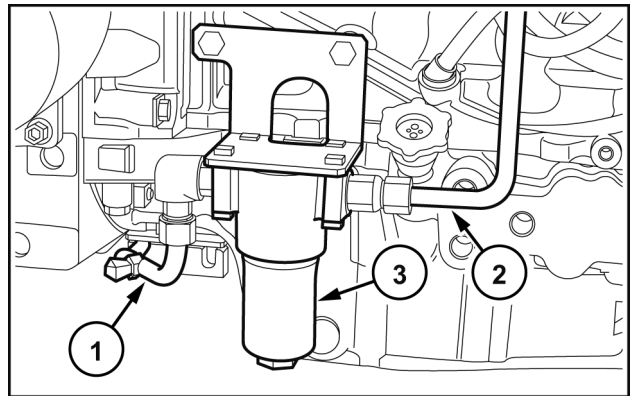

WLAPL4S10C126A 19

22. Detach the oil filter inlet pipe from the transmission (2).  
 23. Detach the supply pipe (1) from the mid-mount remote valves.

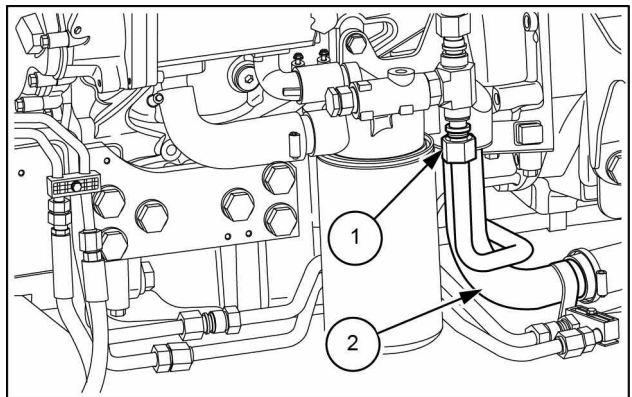

MOIL13TR01799AA 20

24. Detach the pipes (2) of the heat exchanger and, if applicable, of the front braking assembly (1).  
 25. Free the pipes that were previously detached from the supports, brackets, and clamps secured to the engine. Also do the same thing for the pipes directed to the cylinder (3).

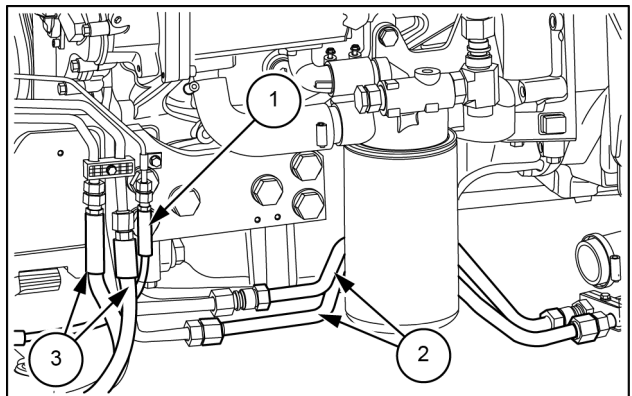

MOIL13TR01800AA 21

26. On the right-hand side, detach the cab heating pipes (1), the pipe inserted on the engine sleeve (2) coming from the expansion tank. Then loosen the clamps. Detach from the engine the lower (3) and upper rubber sleeves of the radiator-engine connection.

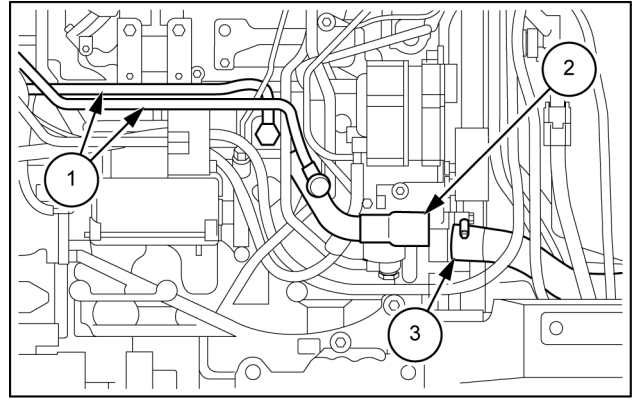

MOIL13TR01739AB 22

27. On the right-hand side, remove the shroud (1) on the starter motor (2). Disconnect the starting cable, the battery cut-off switch, and the cable that joins it to the alternator. Also disconnect the alternator and the battery positive. Free all of the wire harnesses detached from the various clamps.
28. Detach the mounting bolt (3). Then remove the ground cable of the engine and battery system. Remove the other mounting bolts of the motor and remove it.

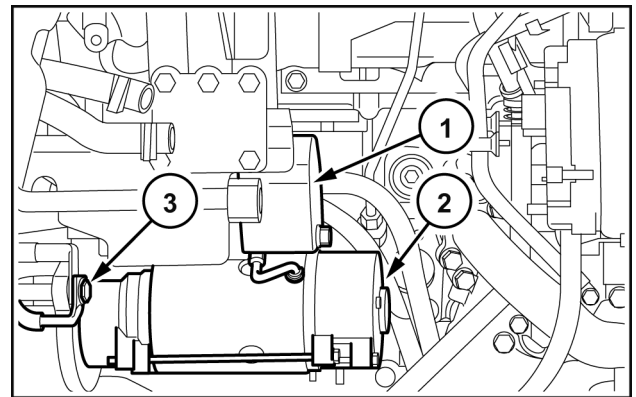

WLAPL4S10C135A 23

29. On the cable (1) of the FTP cable-engine interface, detach all of the connections (2). Leave only those connections on the maxi fuse case and on the glow plug controller. Then, after cutting the clamps, pick up the cable on the front, near the controller (5).
30. Starting from the connector on the controller (4), on the main engine cable (3) disconnect the connectors from the maxi fuse box and from the various switches and sensors located on the engine. After freeing the connector from the clamps, move the connector onto the back, at the height of the right-hand steps.

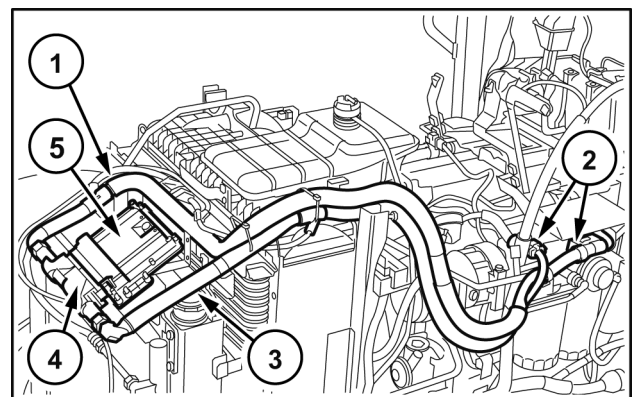

WLAPL4S10C137A 24

31. On the left-hand side, disconnect the connector of the power cable of the cab (1). Free the connector from the clamps. Move the connector onto the maxi fuse box.
32. Detach the bracket (2) supporting the cab connectors, cab power, and cup filter (3). Disconnect the pipe that joins the latter to the mechanical priming pump on the sediment filter.

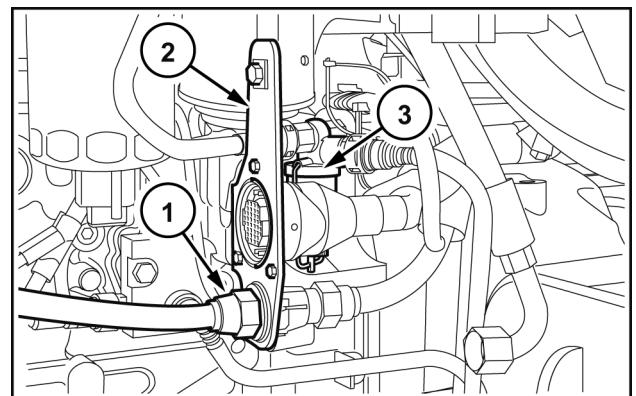

WLAPL4S10C139A 25



33. Hook the rear part of the engine to a hoist using chains or ropes for lifting. (Apply two eyebolts, one to the right-hand side and one to the left-hand side, on the upper part of the flange containing the flywheel.) Position a fixed jack stand (2) under the clutch case (1) near the engine attachment flanging. Apply the hand brake.

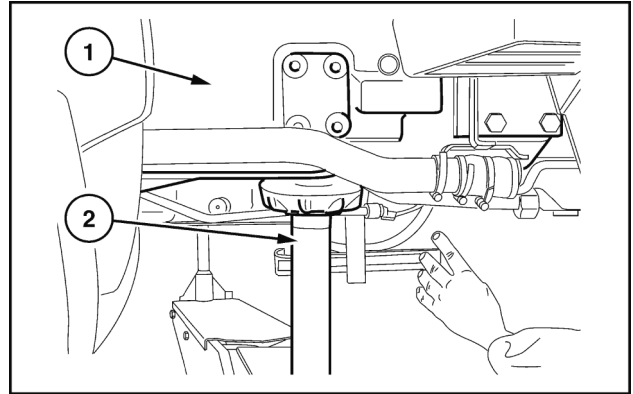

WLAPL4S10C129A 26

34. Position the movable tool for dismantling tractors (2) 380000405 with the bracket and adapter plate under the engine. Place a wooden block (1) between the points of contact between the tool and the engine. Wedge the axle to prevent swinging.

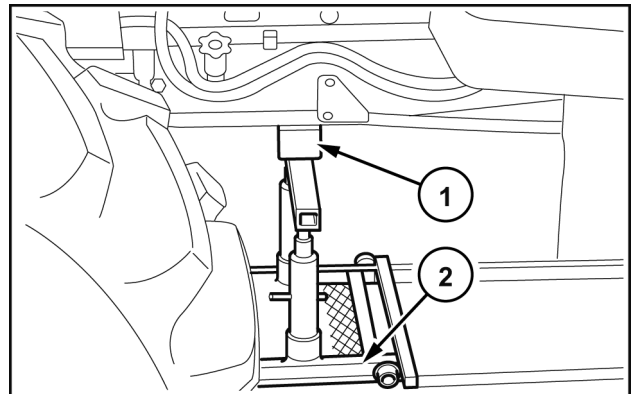

WLAPL4S10C140A 27

35. Remove the retaining bolts (1) between the engine and the transmission.

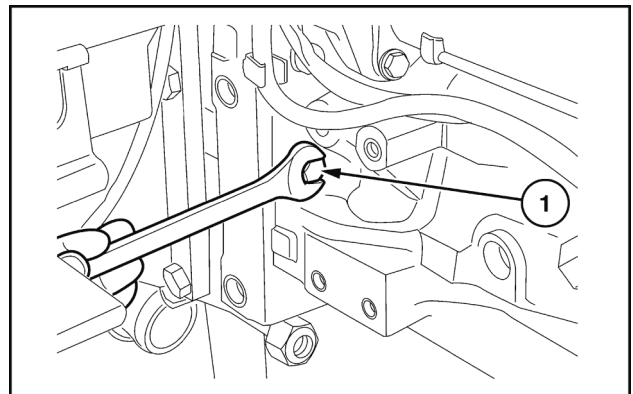

WLAPL4S10C130A 28

36. Separate the engine (1) from the transmission with the appropriate tool 380000405 (2).

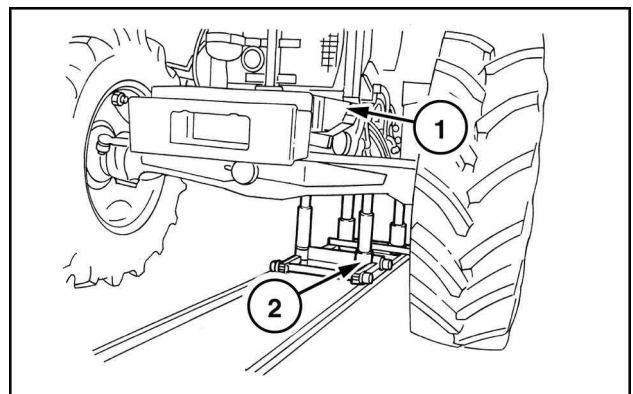

WLAPL4S10C131AA 29

37. Insert a fixed jack stand (1) under the ballast support. Chock the front wheels with wooden wedges (2).

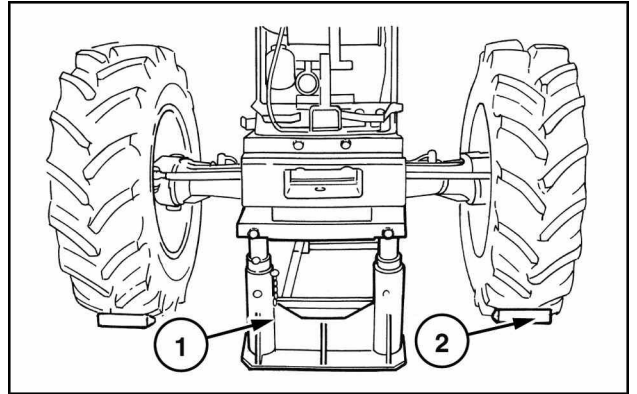

WLAPL4S10C132AA 30

38. Position a fixed jack stand (3) under the support of the groove (1) of the drive of the front axle, inserting a wooden plug (2) between parts (3) and (1).

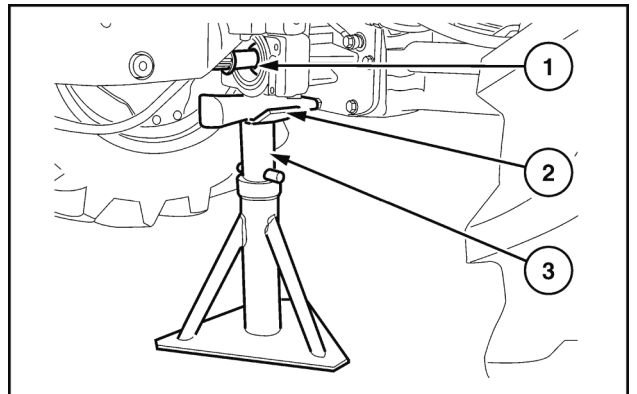

WLAPL4S10C133A 31

39. Position a jack stand under the rear of the engine so as to be able to safely release the hoist with the coupling device. Add a rope or chain (1) also on the front of the engine. Take up the slack with the lifting device, keeping the engine balanced.

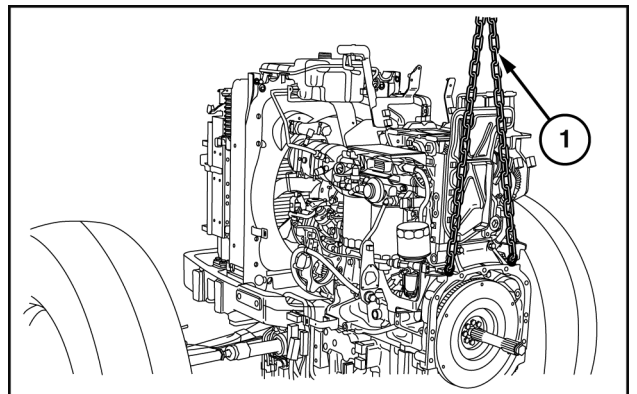

WLAPL4S10C136A 32

40. Remove the bolts (2) fastening the front axle support (1) to the engine.

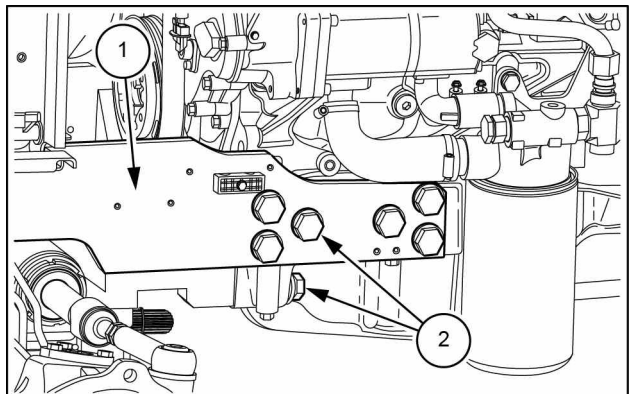

MOIL13TR01801AA 33

41. Check that there are no brackets between the engine and the cooling assembly. Detach the engine (2) from the front axle (3). Try to avoid incorrect maneuvers with the hoist in order to not damage the fins of the radiator on the axle with the engine fan (1). Rest the engine (2) on a support.

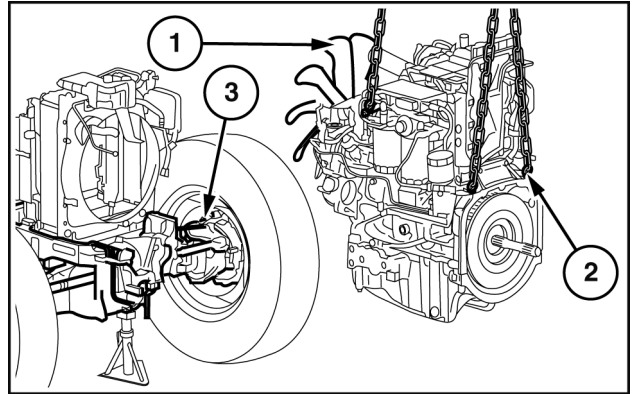

WLAPL4S10C138A 34

42. Remove the viscous coupling (1), together with the fan (2).

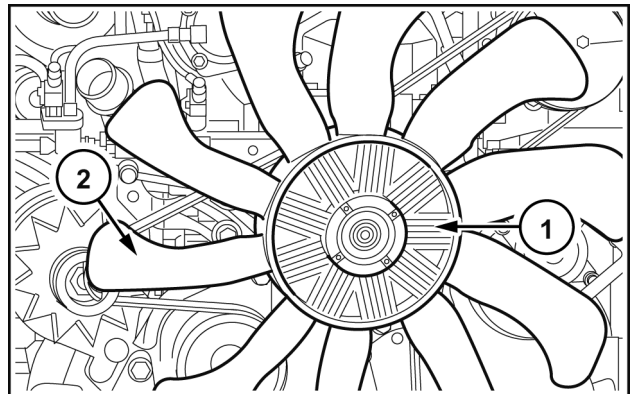

WLAPL4S10C144A 35

43. Loosen the compressor fixing screws (4). Remove the belt (5). Then remove the compressor.
44. Completely loosen the belt tensioner (2). Remove the flexible belt (3). Then remove the alternator (1).

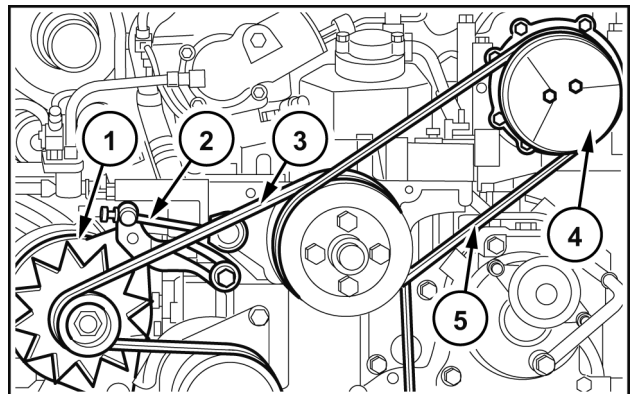

WLAPL4S10C145A 36

## Engine - Install

|  |  |
|--|--|
| T4.105 with cab, with mechanical or power shuttle transmission [ZxJT0xxxx] |  |
| T4.105 less cab, with mechanical or power shuttle transmission [ZxJT0xxxx] |  |
| T4.115 with cab, with mechanical or power shuttle transmission [ZxJT0xxxx] |  |
| T4.115 less cab, with mechanical or power shuttle transmission [ZxJT0xxxx] |  |
| T4.75 with cab, with mechanical or power shuttle transmission [ZxJT0xxxx]  |  |
| T4.75 less cab, with mechanical or power shuttle transmission [ZxJT0xxxx]  |  |
| T4.85 with cab, with mechanical or power shuttle transmission [ZxJT0xxxx]  |  |
| T4.85 less cab, with mechanical or power shuttle transmission [ZxJT0xxxx]  |  |
| T4.95 with cab, with mechanical or power shuttle transmission [ZxJT0xxxx]  |  |
| T4.95 less cab, with mechanical or power shuttle transmission [ZxJT0xxxx]  |  |

1. Refit the flexible belt on the alternator and take up the slack according to the procedure in **Alternator - Tension adjust (55.301)**.
2. Reposition the compressor and the relevant belt following this procedure:
  - Put the compressor back on the support and with the related pipe support. Secure with the bolts
  - To mount the polyv belt, use the specific tool **380200011**.
    - (1). Compressor clutch actuator drive bracket.
    - (2). polyv belt pulley outer edge.
    - (3). Tool recess. Used to drive the tool. This recess houses the bracket (1).
    - (4). Tail. Used to drive the polyv belt in the pulley seat.
    - (5). Hitching. Thanks to this recess, where the outer edge (2) is housed, the tool remains hitched to the compressor.

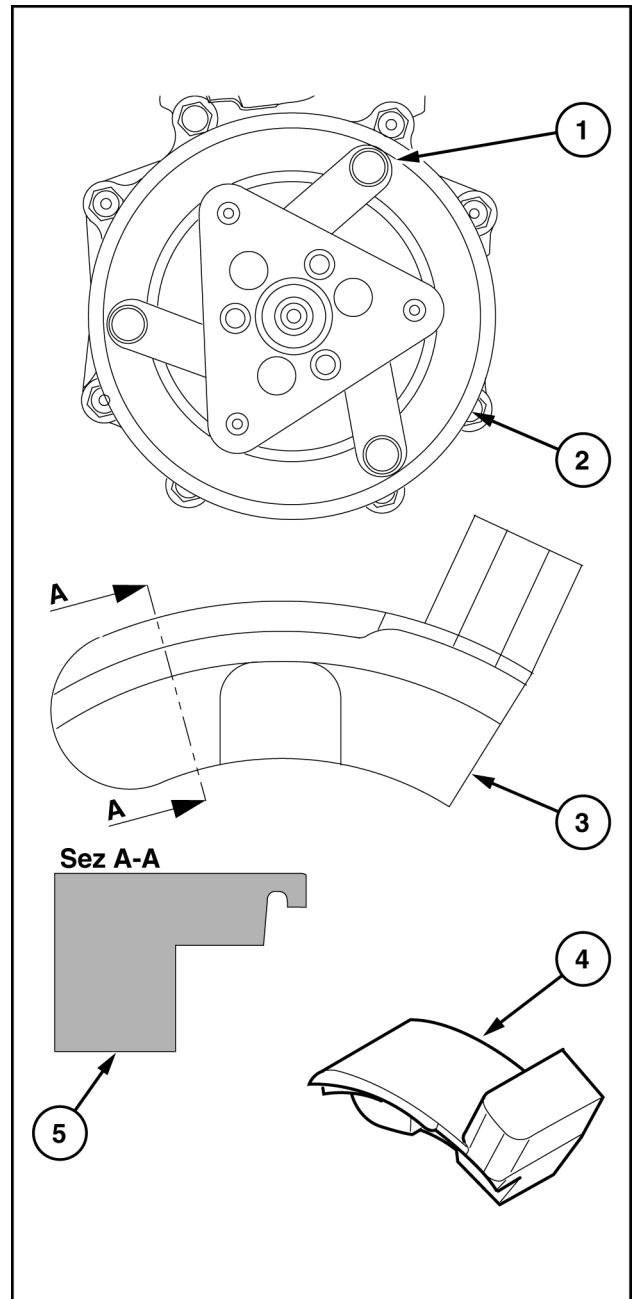

WLAPL4S10C101C 1

3. Remove the three bolts (1) and the related dust cover for the compressor clutch.

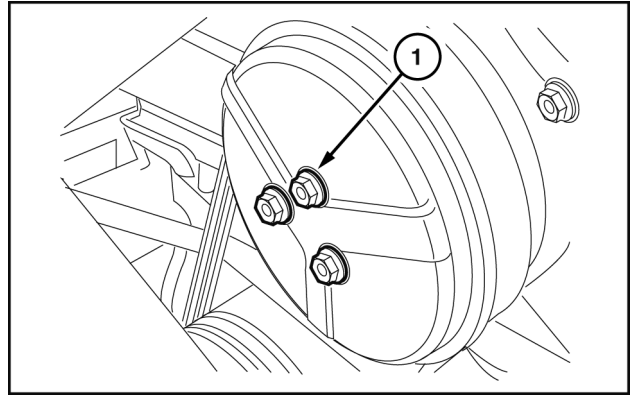

WLAPL4S10C142A 2

4. Ensure that the polyv belt (2) is perfectly housed on the fan pulley.
5. Move the belt (2) near to the compressor pulley. Keeping the tool 380200011 under the belt, hook the tool onto the compressor clutch at the innermost part in order to slightly force the belt.

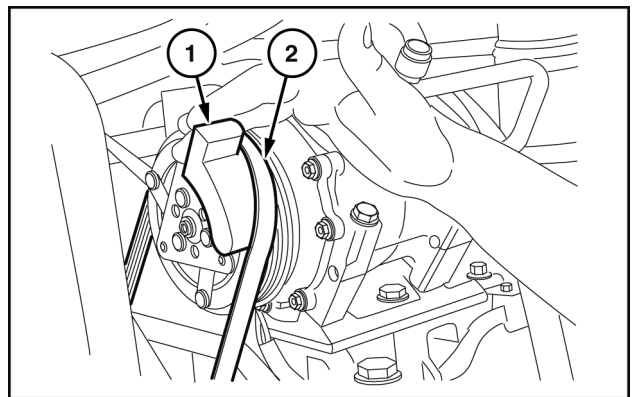

WLAPL4S10C143A 3

6. With your left hand on the fan and right hand on the tool, move both clockwise in order to take the belt onto the compressor pulley. Put the dust cup back onto the compressor clutch. Tighten the three screws, ensuring that you spread a film of thread lock on the ends so that they do not come loose.
7. Position the alternator (1) and the elastic belt (3). Tighten the belt tensioner (2).

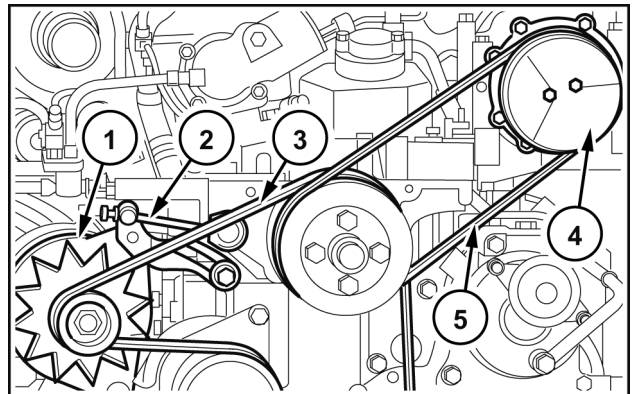

WLAPL4S10C145A 4

8. Refit the cooling fan (1).

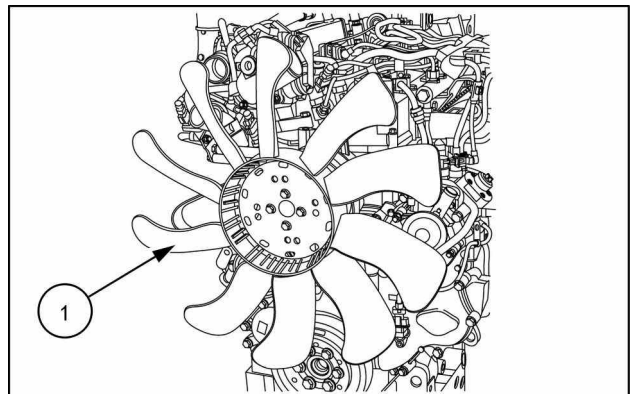

MOIL14UTL0038AA 5

9. Insert the three hooks of the chain in the eyelets on the engine. Using a hoist, lift the assembly off the platform support.
10. Position the engine (2) on the front axle (3), trying to avoid incorrect operations with the hoist so as not to let the engine fan damage the fins of the radiator (1). Then join the two assemblies together with the four retaining bolts and the necessary adjuster spacers for the cylinder block/sump support.

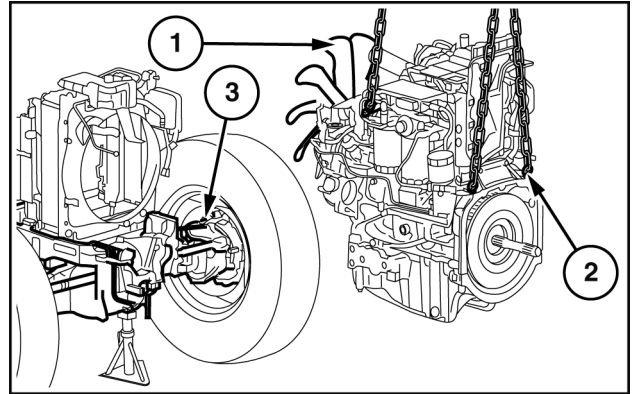

WLAPL4S10C138A 6

11. Reposition the movable tool for dismantling tractors (2) under the engine. Place a wooden block (1) in the point of contact between the tool and the engine.

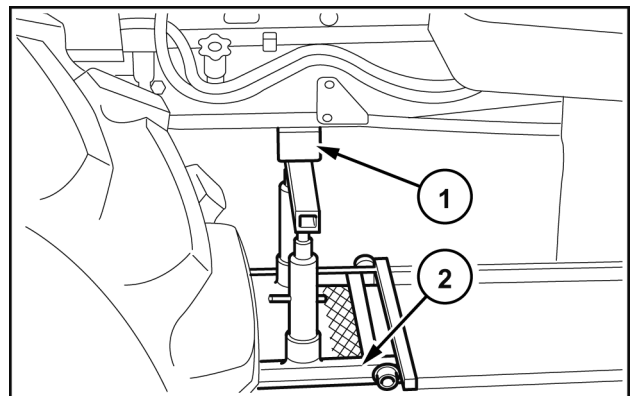

WLAPL4S10C140A 7

12. With the aid of the hoist, place the engine (1) on the tool (2). Remove the lifting eyebolts previously fitted on the rear of the engine.

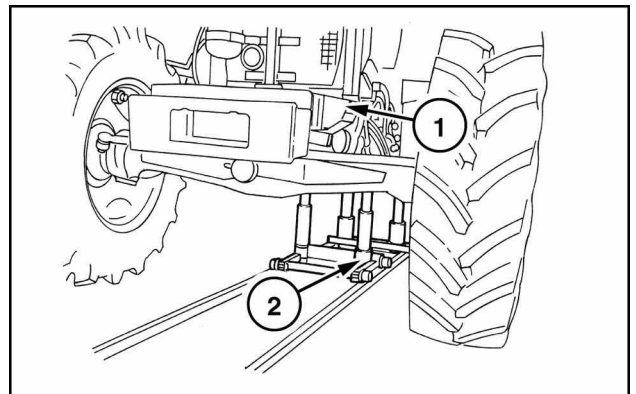

WLAPL4S10C131AA 8

13. Remove the fixed jack stand (3) previously positioned under the support of the groove (1) of the drive of the front axle and the wooden plug (2).

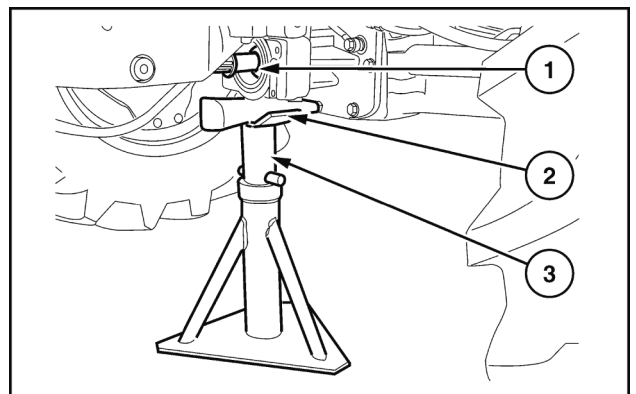

WLAPL4S10C133A 9

14. Remove the fixed jack stand (1) previously fitted under the ballast support and the wooden wedges (2) locking the front wheels.

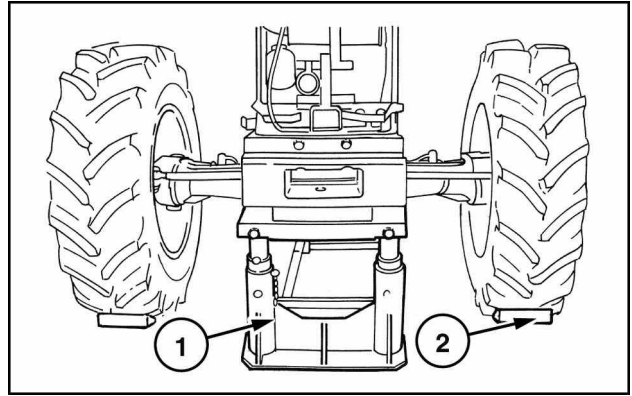

WLAPL4S10C132AA 10

15. Remove the old sealing paste from the two surfaces between the engine and clutch case.
16. Apply **LOCTITE® 518™** sealing compound on the mating surfaces of the engine and clutch case.
17. Put a wooden wedge under the right-hand rear wheel. Make sure that the hand brake is fully applied and that all fixed and mobile stands are safely positioned.
18. The installation phase described here requires the presence of two or three workers to use the specific movable tool for dismantling tractors to move the engine/front axle assembly close to the gearbox case.
19. In the phase of installing the engine/front axle assembly to the gearbox case, it is necessary to push on the front wheels, taking great care in the end phase of coupling over both the pipes and the cables/electrical connections to prevent crushing between the two bodies. Moreover, during this phase it is necessary to turn the crankshaft with the aid of the radiator cooling fan to aid coupling between the sleeve and the drive shaft.
20. Secure both assemblies by tightening all the bolts (1) locking the engine to the gearbox case.

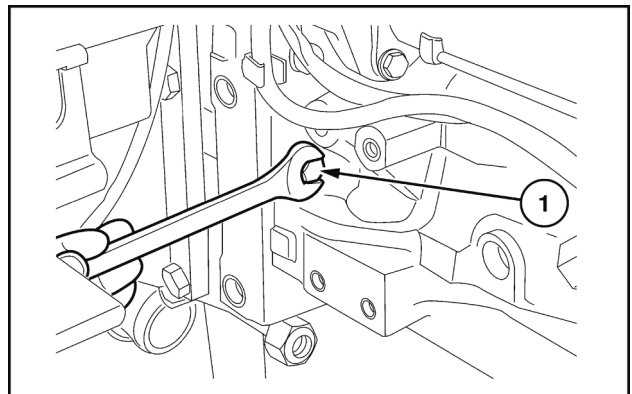

WLAPL4S10C130A 11

21. Disconnect the hoist chains. Remove the jack stand **(2)** previously fitted under the clutch case **(1)**. Retrieve the movable tool for dismantling tractors.

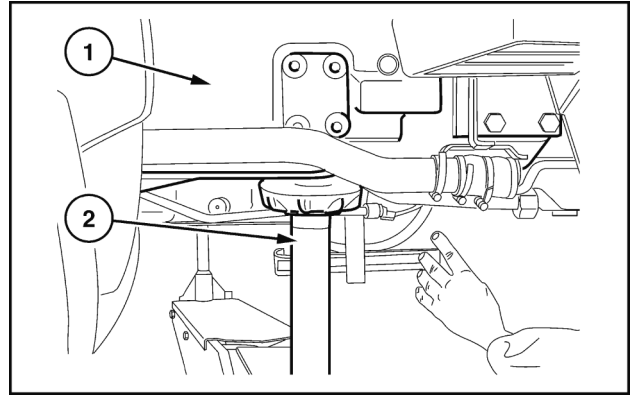

WLAPL4S10C129A 12

22. Refit the bracket **(2)** supporting the cab connectors, cab power and cup filter **(3)**. Connect the pipe that joins the latter to the mechanical priming pump on the sediment filter.
23. On the left-hand side, connect the cab power cable connector **(1)**. Put the connector on the maxi fuse box and lock with clamps.

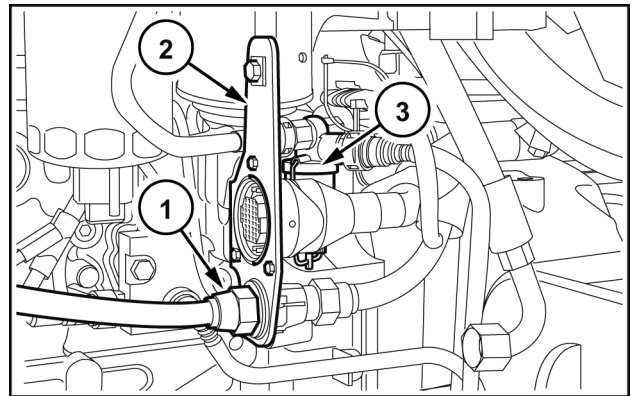

WLAPL4S10C139A 13

24. Return the main engine cable **(3)** back into position. Connect the sensors and switches located on the engine, the connectors **(4)** on the controller **(5)** and on the maxi fuse compartment. Fasten the wiring with clamps.
25. Lay out the FTP interface - engine cable **(1)** on the machine. Reconnect the various connections **(2)**. Secure the wiring with clamps.

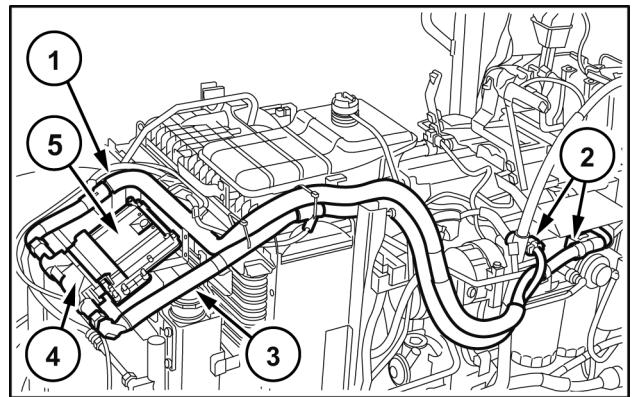

WLAPL4S10C137A 14

26. Refit the starter motor **(2)**. Then connect the ground cable of the engine and battery system. Secure the ground cable with the bolt **(3)**.
27. On the right-hand side, reconnect the battery positive cable and the wirings to the starter motor, battery cut-off switch and alternator. Refit the shroud **(1)** on the starter motor **(2)**.

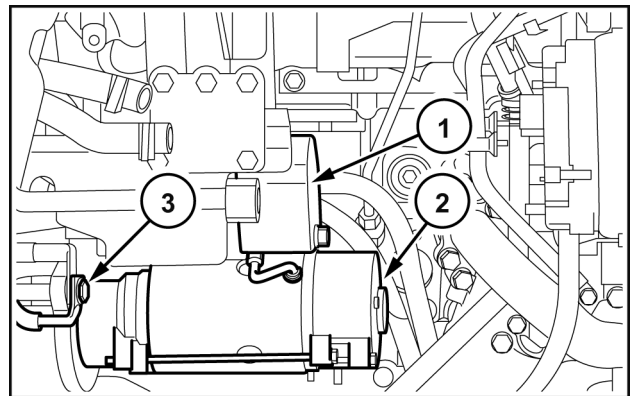

WLAPL4S10C135A 15



28. Refit the two supply and return lines to the cab heater (1) and the pipe (3) inserted on the lower sleeve coming from the expansion tank. Refit the upper and lower sleeves (4) of the engine radiator connection. Secure the straps and clamps tightening the pipes.

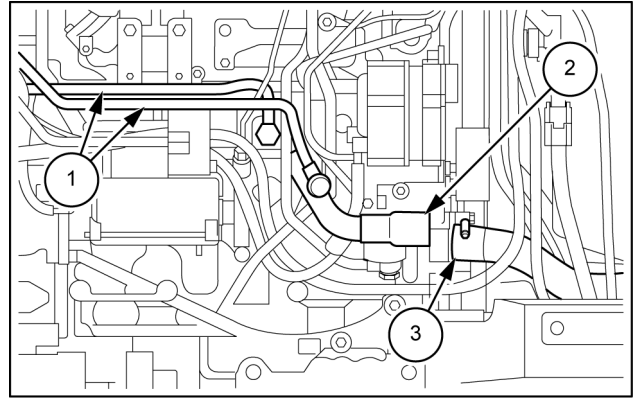

MOIL13TR01739AB 16

29. Reconnect the power steering control valve oil filter together with the support (3). Reconnect the oil drain line (2) from the power steering and the supply line to the control valve of the gearbox (1).

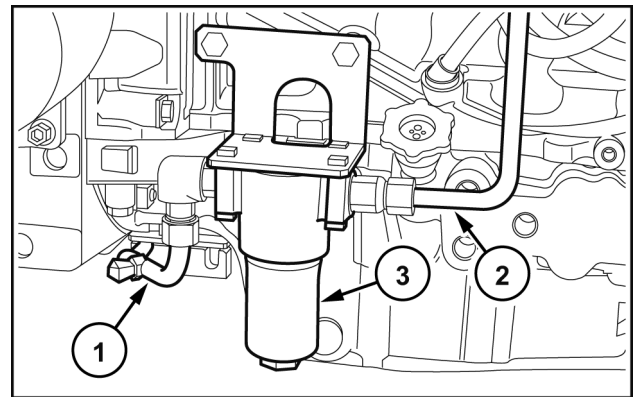

WLAPL4S10C126A 17

30. Refit the two pipes (2) of the heat exchanger and, if present, of the front braking assembly (1).

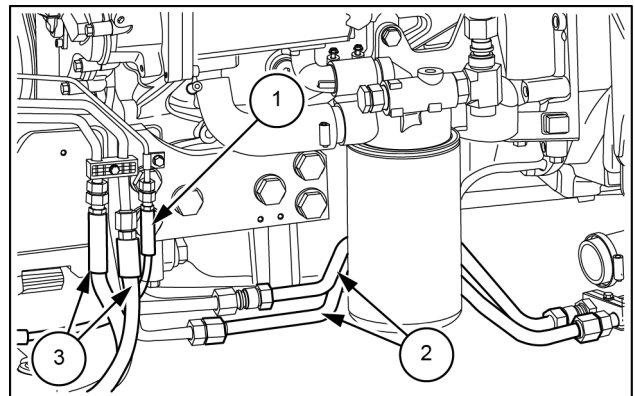

MOIL13TR01800AA 18

31. Reconnect the supply line to the mid-mount remote valves and the oil filter suction from the transmission (1).

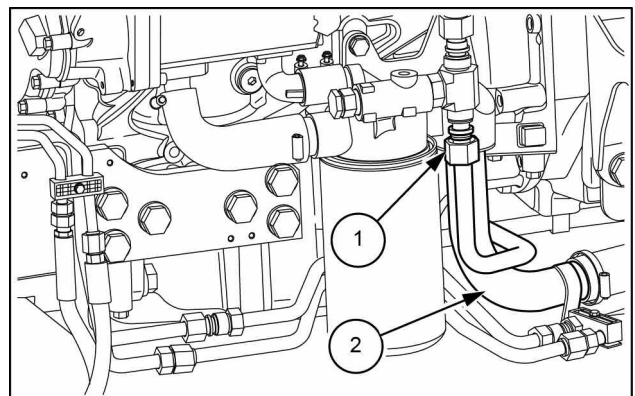

MOIL13TR01799AA 19

32. Connect the pipes to the power steering cylinder (1) and (2). Connect the power supply to the control valve (3). Refit the fixture (4).

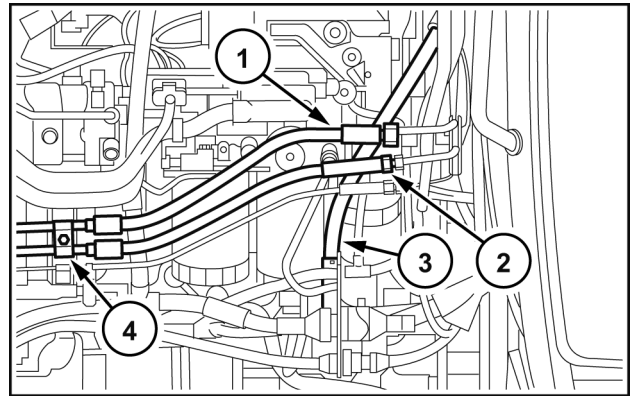

WLAPL4S10C125A 20

33. If it was necessary to remove the DPF support, proceed as follows:

- 1 – Mount the upper support (1) on the right-hand one (2) with the three Allen screws.
- 2 – Mount the left-hand support (5) securing it to the engine with the three lower screws.
- 3 – Mount the assembly of the supports (1) and (2) to the engine with the four screws in position (3), respecting the reference marks made when dismantling.
- 4 – Secure the support (5) to the support (1) with the two upper screws and the two adjustment bushings.
- 5 – Secure the support (4) to the engine with the two lower screws, to the support (5) with the three left-hand screws and to the support (1) with the two upper screws.

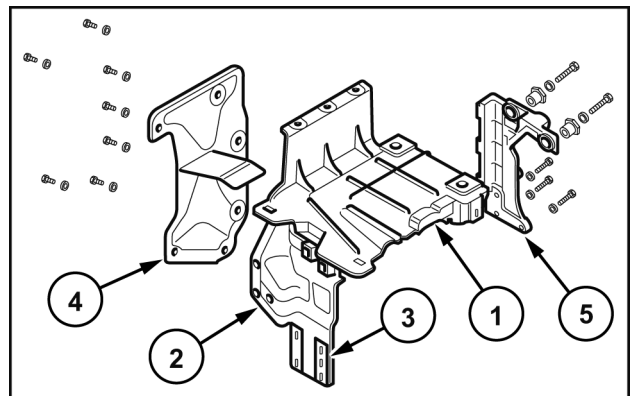

WLAPL4S10C124A 21

34. Refit the DPF filter assembly. Return the entire unit into position. Fasten the four fixing screws of the assembly to the cradle.

Observation:

If, after refitting the DPF filter, you find a slight misalignment with the axis of the turbine, it is possible to make a correction. On the two screws fixing the filter to the cradle there are two threaded bushings (2) held in position by a grub screw (1).

Loosen the grub screw with an Allen key. Tighten or loosen the bushing by the amount necessary to correct the misalignment. Retighten the grub screw. Secure the support.

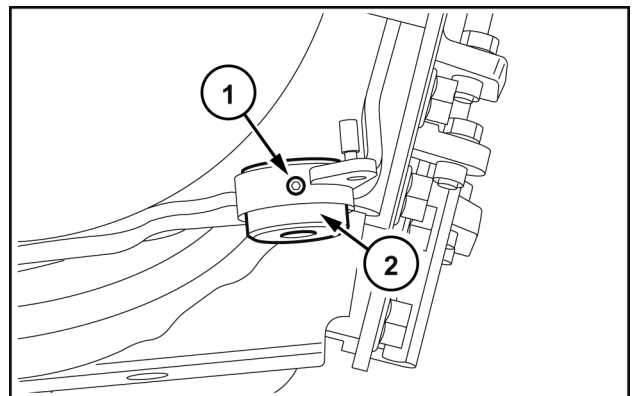

WLAPL4S10C146A 22

35. Tighten the clamp (4). Fix the filter to the bottom cradle using the four screws (5). Reconnect all of the sensors.

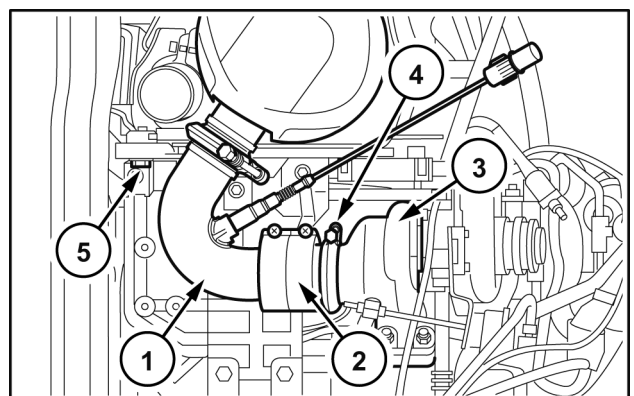

WLAPL4S10C122A 23

**ATTENTION:** The filter outlet union DPF (1) at its terminal (2) has a decoupler that responds to temperature variations by changing length.

*A small misalignment of the axis of the decoupler with respect to the axis of the turbine outlet (3) would produce an adjustment that would no longer be lengthwise, in line with the direction of the tractor, but abnormal transversal adjustment that would impair its durability.*

36. Refit the hood support of the air filter bracket (1).

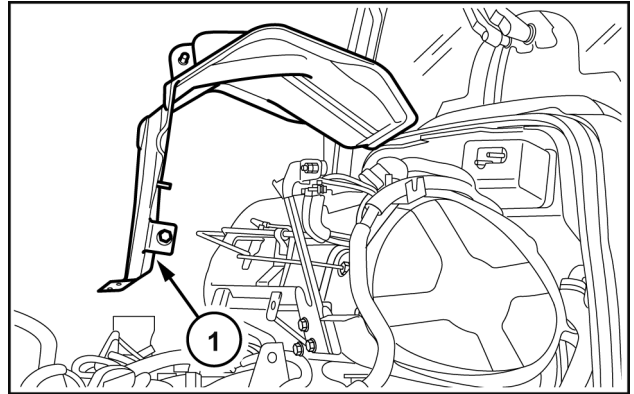

WLAPL4S10C121A 24

37. Reassemble the air filter unit (4) and the respective support (3). Fix the screws on the filter bracket and on the supply duct on the radiator. Refit the sleeve connected to the turbine (2), and the oil vapor duct (1).

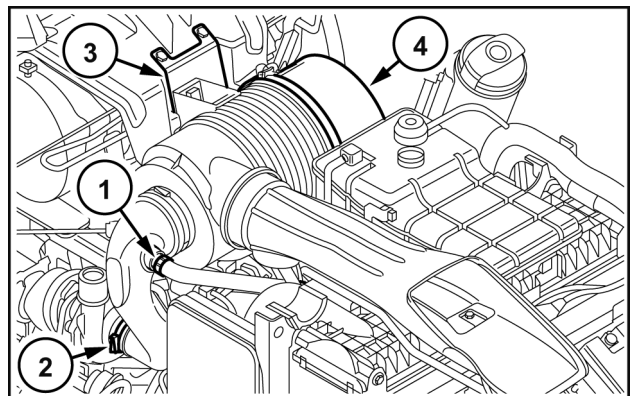

WLAPL4S10C120A 25

38. Refit the two pipes (2) and (3) to the radiator inter-cooler. Tighten the respective clamps (1).

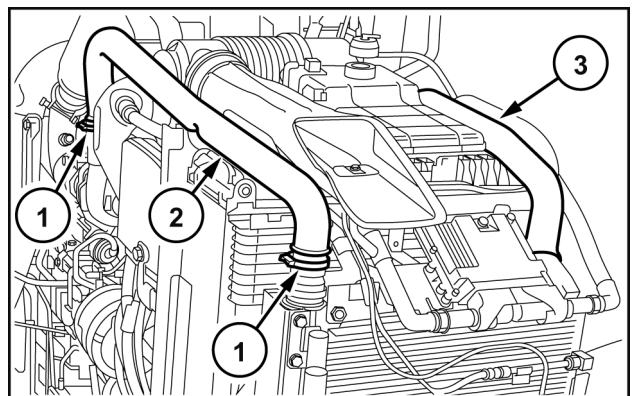

WLAPL4S10C119A 26

39. Refit the exhaust pipe (3). Tighten the relevant retaining clamps (1) and (2).

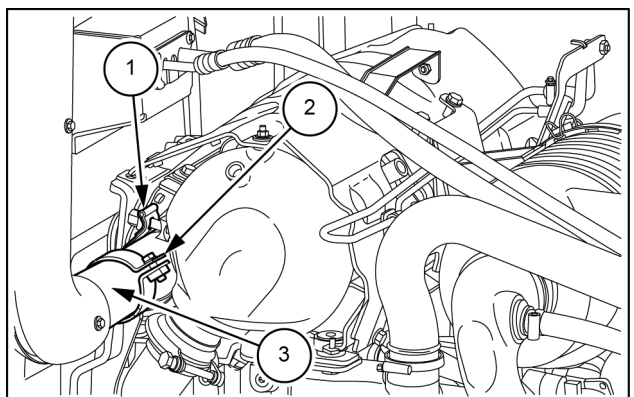

MOIL13TR01798AA 27

40. Refit the transmission oil drain plug (1). Refill with oil using a pump.

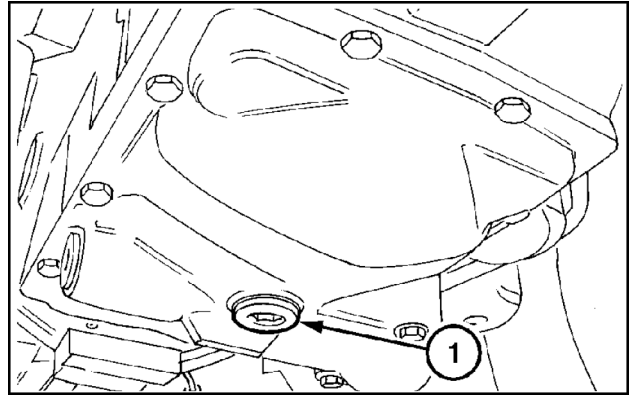

MOIL13TR00197AA 28

41. Refit the drive shaft together with the central support (1) and the retaining bolts. Insert the shim. Adjust the shaft end play.

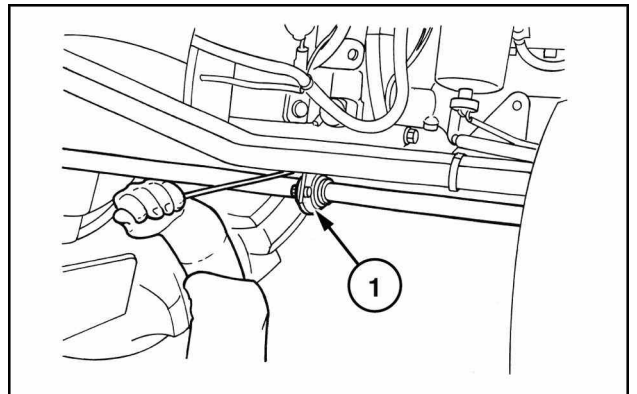

WLAPL4S10C115AA 29

42. Refit the guard of the front axle control shaft (1). Tighten the front, central, and rear retaining bolts.

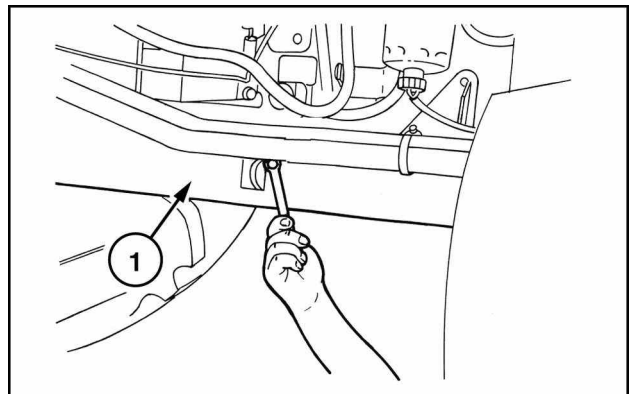

WLAPL4S10C112AA 30

43. Using a hydraulic jack, raise the rear of the tractor. Remove the mechanical jack stand under the left-hand reduction gear. Put the wheel back into position. Fit the retaining nuts with a pneumatic gun.

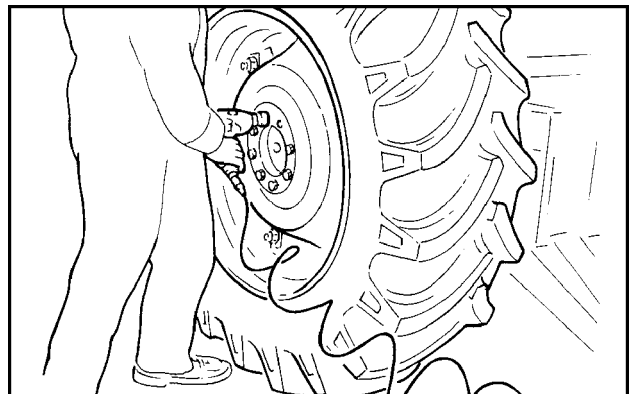

WLAPL4S10C110A 31

44. Reconnect the air-conditioning lines (3) and the sensor (2) to the condenser (1). Fix them with clamps and brackets.

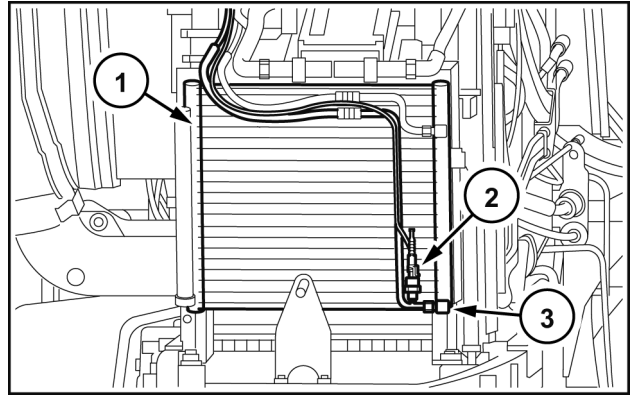

WLAPL4S10C107A 32

45. Reconnect the air-conditioning lines (1) and (2) on the compressor. Secure the lines with clamps and brackets.
46. Top up the air-conditioning system with refrigerant using the specific controller **380000315**.

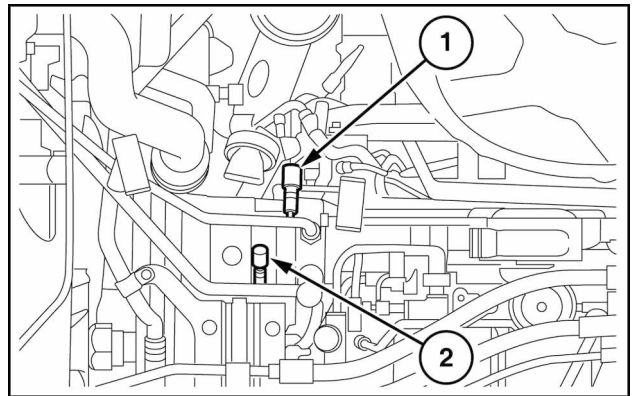

WLAPL4S10C106AA 33

47. Refit the front wheel fenders (2), if applicable. Tighten the respective fixtures (1).

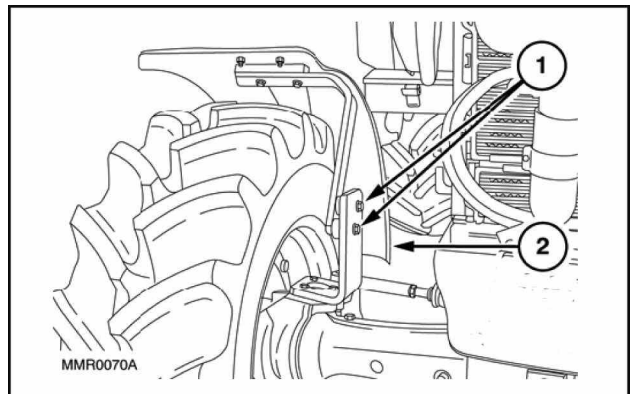

MMR0070A

WLAPL4S10C104A 34

48. Re-install the tank, as described in **Fuel tank - Install (10.216)**.
49. Re-install the battery, as described in **Battery - Install (55.302)**.
50. Refit the engine hood, as indicated in **Hood - Install (90.100)**.

## Engine - Install

|   |  |
|---|--|
| T4.105 with cab, with hi-lo transmission [ZxJT0xxxx]                              |  |
| T4.105 with cab, with hi-lo transmission, with Supersteer™ front axle [ZxJT0xxxx] |  |
| T4.105 less cab, with hi-lo transmission [ZxJT0xxxx]                              |  |
| T4.115 with cab, with hi-lo transmission [ZxJT0xxxx]                              |  |
| T4.115 less cab, with hi-lo transmission [ZxJT0xxxx]                              |  |
| T4.75 with cab, with hi-lo transmission [ZxJT0xxxx]                               |  |
| T4.75 with cab, with hi-lo transmission, with Supersteer™ front axle [ZxJT0xxxx]  |  |
| T4.75 less cab, with hi-lo transmission [ZxJT0xxxx]                               |  |
| T4.85 with cab, with hi-lo transmission [ZxJT0xxxx]                               |  |
| T4.85 with cab, with hi-lo transmission, with Supersteer™ front axle [ZxJT0xxxx]  |  |
| T4.85 less cab, with hi-lo transmission [ZxJT0xxxx]                               |  |
| T4.95 with cab, with hi-lo transmission [ZxJT0xxxx]                               |  |
| T4.95 with cab, with hi-lo transmission, with Supersteer™ front axle [ZxJT0xxxx]  |  |
| T4.95 less cab, with hi-lo transmission [ZxJT0xxxx]                               |  |

1. Refit the flexible belt on the alternator and take up the slack according to the procedure in **Alternator - Tension adjust (55.301)**.

2. Reposition the compressor and the relevant belt following this procedure:

- Put the compressor back on the support and with the related pipe support. Secure with the bolts

- To mount the polyv belt, use the specific tool **380200011**.

(1). Compressor clutch actuator drive bracket.

(2). polyv belt pulley outer edge.

(3). Tool recess. Used to drive the tool. This recess houses the bracket (1).

(4). Tail. Used to drive the polyv belt in the pulley seat.

(5). Hitching. Thanks to this recess, where the outer edge (2) is housed, the tool remains hitched to the compressor.

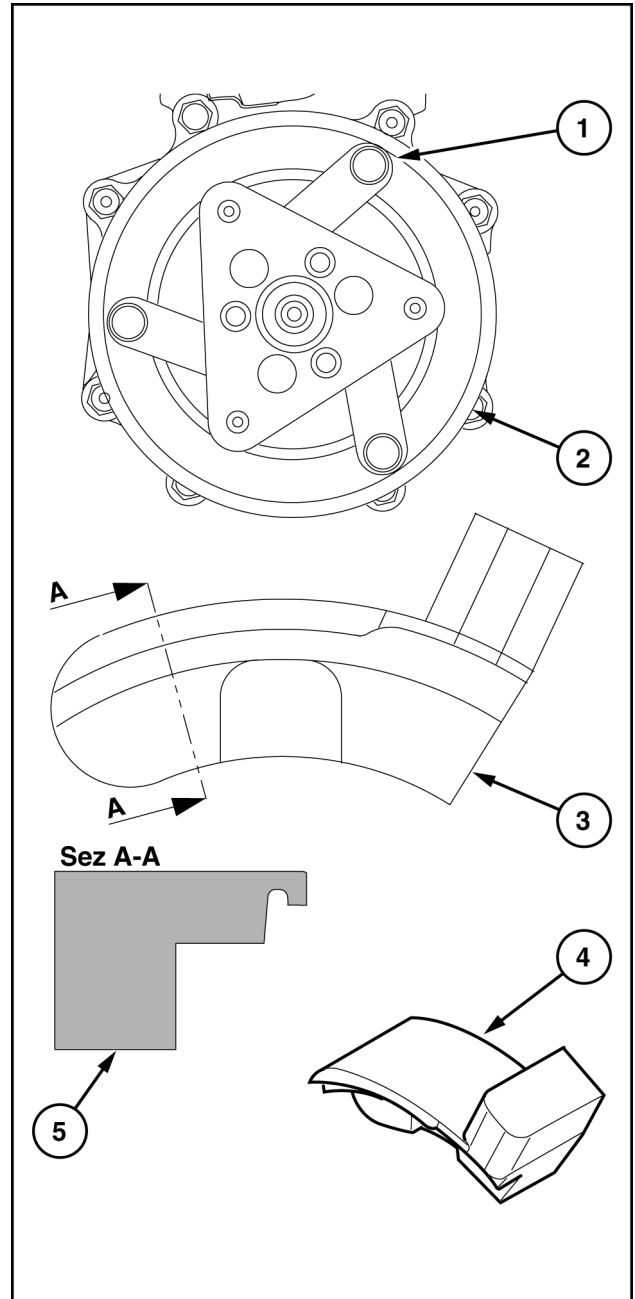

WLAPL4S10C101C 1

3. Remove the three bolts (1) and the related dust cover for the compressor clutch.

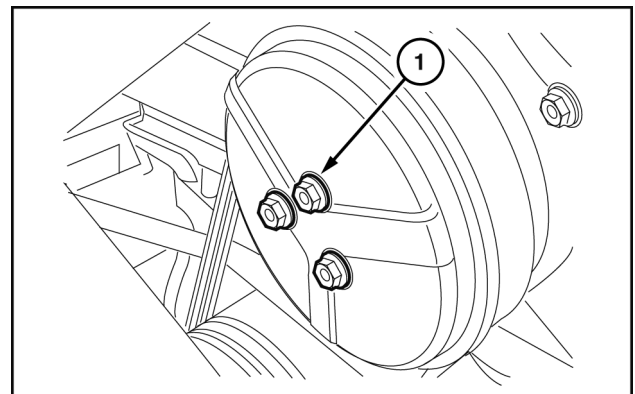

WLAPL4S10C142A 2

4. Ensure that the polyv belt (2) is perfectly housed on the fan pulley.

5. Move the belt (2) near to the compressor pulley. Keeping the tool **380200011** under the belt, hook the tool onto the compressor clutch at the innermost part in order to slightly force the belt.

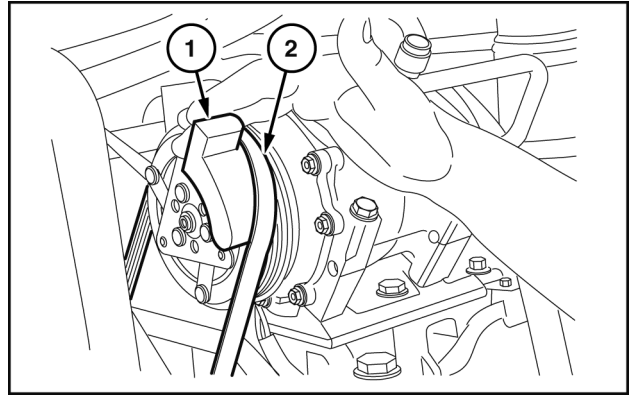

WLAPL4S10C143A 3

6. With your left hand on the fan and right hand on the tool, move both clockwise in order to take the belt onto the compressor pulley. Put the dust cup back onto the compressor clutch. Tighten the three screws, ensuring that you spread a film of thread lock on the ends so that they do not come loose.
7. Position the alternator (1) and the elastic belt (3). Tighten the belt tensioner (2).

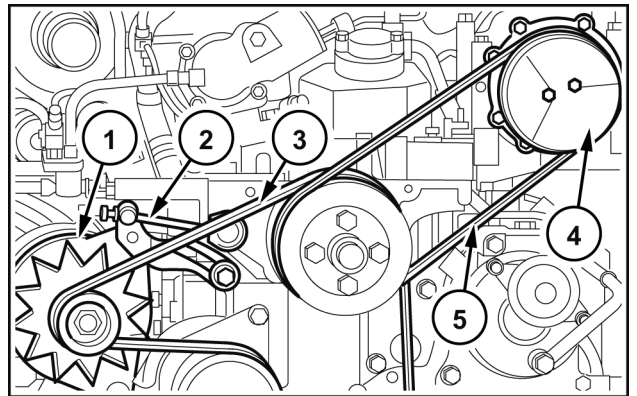

WLAPL4S10C145A 4

8. Reposition the viscous joint (1) and the cooling fan (2).

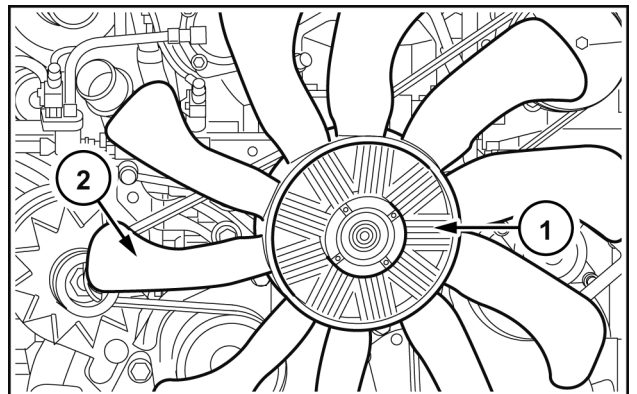

WLAPL4S10C144A 5

9. Insert the three hooks of the chain in the eyelets on the engine. Using a hoist, lift the assembly off the platform support.
10. Position the engine (2) on the front axle (3), trying to avoid incorrect operations with the hoist so as not to let the engine fan damage the fins of the radiator (1). Then join the two assemblies together with the four retaining bolts and the necessary adjuster spacers for the cylinder block/sump support.

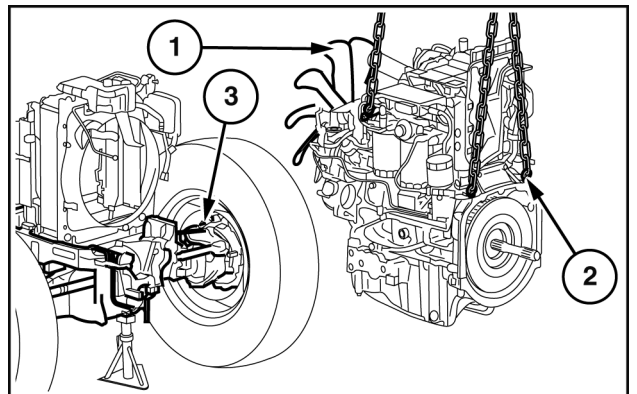

WLAPL4S10C138A 6



11. Reposition the movable tool for dismantling tractors **(2)** under the engine. Place a wooden block **(1)** in the point of contact between the tool and the engine.

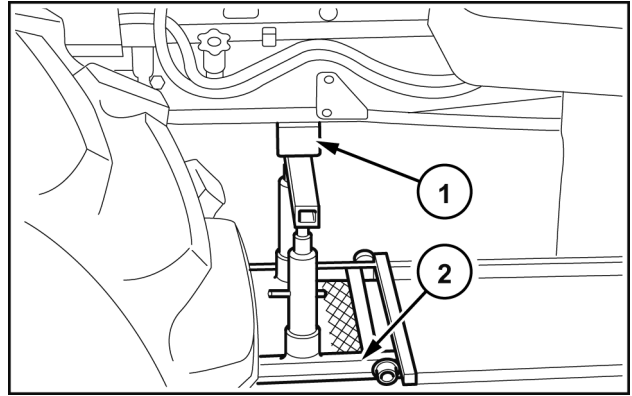

WLAPL4S10C140A 7

12. With the aid of the hoist, place the engine **(1)** on the tool **(2)**. Remove the lifting eyebolts previously fitted on the rear of the engine.

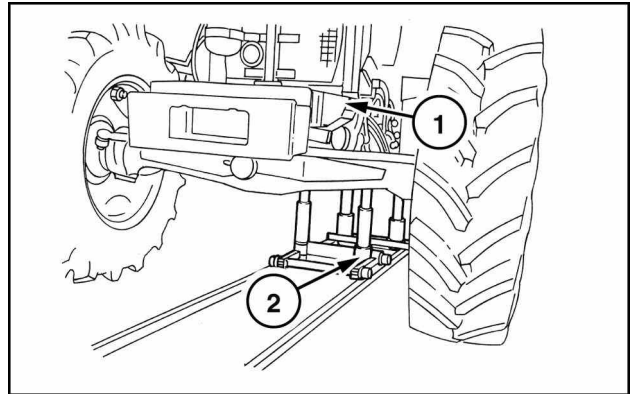

WLAPL4S10C131AA 8

13. Remove the fixed jack stand **(3)** previously positioned under the support of the groove **(1)** of the drive of the front axle and the wooden plug **(2)**.

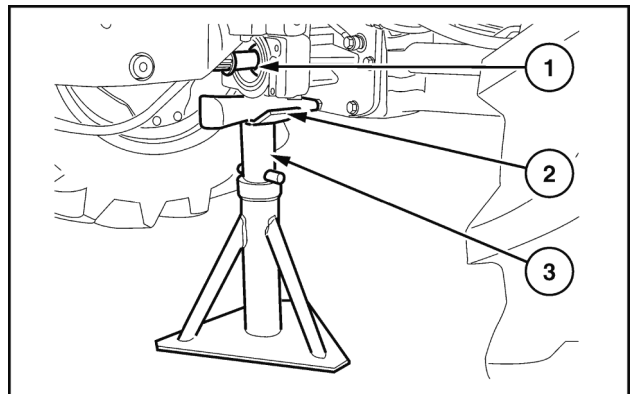

WLAPL4S10C133A 9

14. Remove the fixed jack stand **(1)** previously fitted under the ballast support and the wooden wedges **(2)** locking the front wheels.

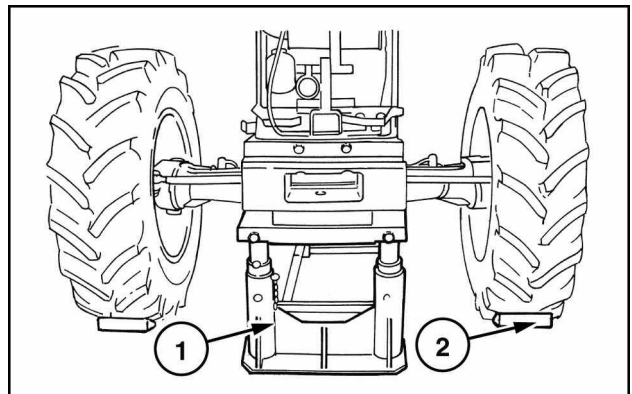

WLAPL4S10C132AA 10

15. Remove the old sealing paste from the two surfaces between the engine and clutch case.

16. Apply **LOCTITE® 518™** sealing compound on the mating surfaces of the engine and clutch case.
17. Put a wooden wedge under the right-hand rear wheel. Make sure that the hand brake is fully applied and that all fixed and mobile stands are safely positioned.
18. The installation phase described here requires the presence of two or three workers to use the specific movable tool for dismantling tractors to move the engine/front axle assembly close to the gearbox case.
19. In the phase of installing the engine/front axle assembly to the gearbox case, it is necessary to push on the front wheels, taking great care in the end phase of coupling over both the pipes and the cables/electrical connections to prevent crushing between the two bodies. Moreover, during this phase it is necessary to turn the crankshaft with the aid of the radiator cooling fan to aid coupling between the sleeve and the drive shaft.
20. Secure both assemblies by tightening all the bolts **(1)** locking the engine to the gearbox case.

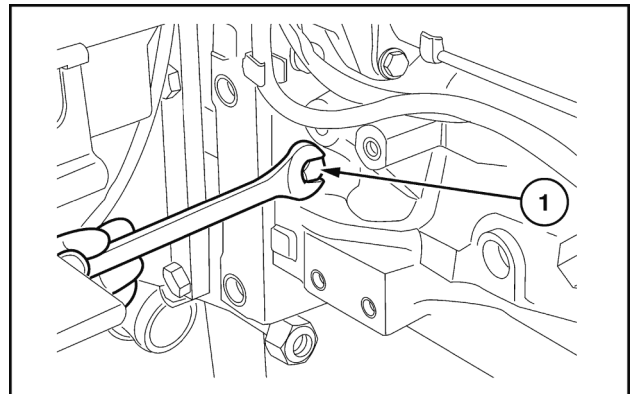

WLAPL4S10C130A 11

21. Disconnect the hoist chains. Remove the jack stand **(2)** previously fitted under the clutch case **(1)**. Retrieve the movable tool for dismantling tractors.

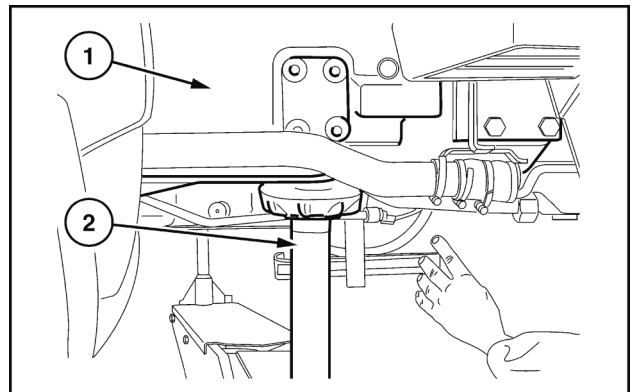

WLAPL4S10C129A 12

22. Refit the bracket **(2)** supporting the cab connectors, cab power and cup filter **(3)**. Connect the pipe that joins the latter to the mechanical priming pump on the sediment filter.

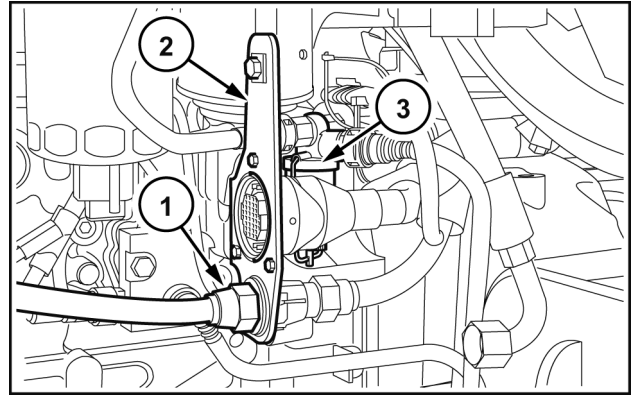

WLAPL4S10C139A 13

23. On the left-hand side, connect the cab power cable connector **(1)**. Put the connector on the maxi fuse box and lock with clamps.

24. Return the main engine cable **(3)** back into position. Connect the sensors and switches located on the engine, the connectors **(4)** on the controller **(5)** and on the maxi fuse compartment. Fasten the wiring with clamps.

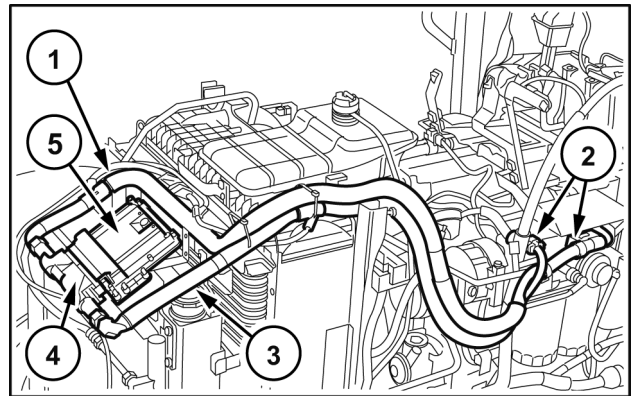

WLAPL4S10C137A 14

25. Lay out the FTP interface - engine cable **(1)** on the machine. Reconnect the various connections **(2)**. Secure the wiring with clamps.

26. Refit the starter motor **(2)**. Then connect the ground cable of the engine and battery system. Secure the ground cable with the bolt **(3)**.

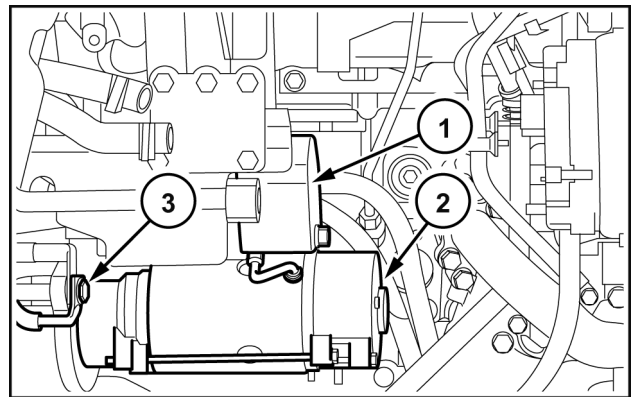

WLAPL4S10C135A 15

27. On the right-hand side, reconnect the battery positive cable and the wirings to the starter motor, battery cut-off switch and alternator. Refit the shroud **(1)** on the starter motor **(2)**.

28. Refit the two supply and return lines to the cab heater **(1)** and the pipe **(3)** inserted on the lower sleeve coming from the expansion tank. Refit the upper and lower sleeves **(4)** of the engine radiator connection. Secure the straps and clamps tightening the pipes.

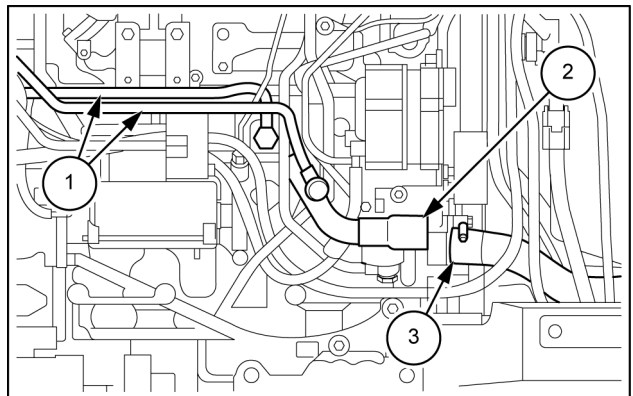

MOIL13TR01739AB 16

29. Reconnect the power steering control valve oil filter together with the support (3). Reconnect the oil drain line (2) from the power steering and the supply line to the control valve of the gearbox (1).

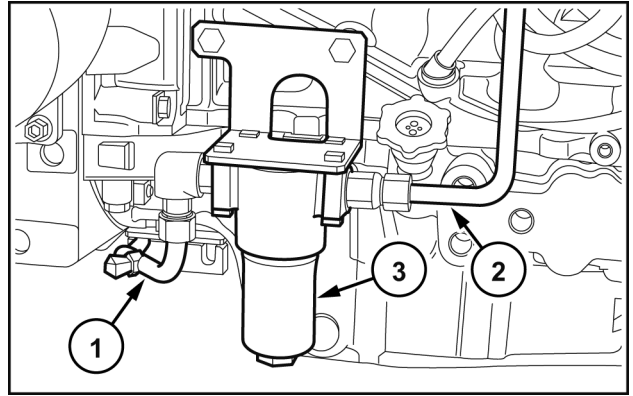

WLAPL4S10C126A 17

30. Refit the two pipes (2) of the heat exchanger and, if present, of the front braking assembly (1).

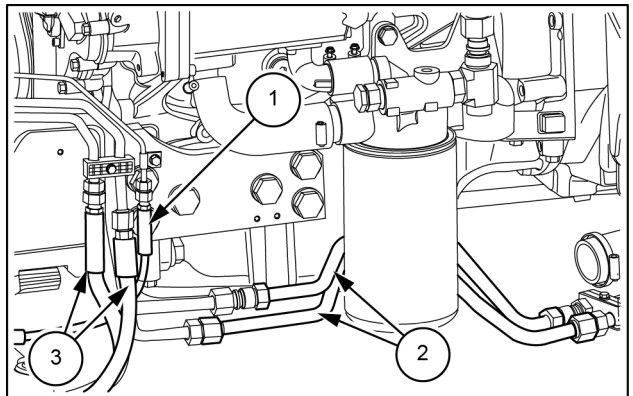

MOIL13TR01800AA 18

31. Reconnect the supply line to the mid-mount remote valves and the oil filter suction from the transmission (1).

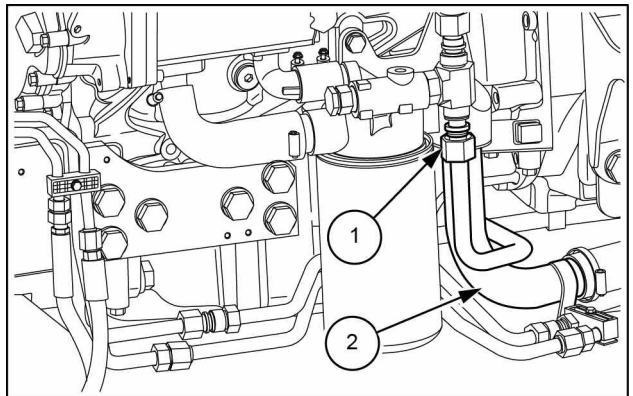

MOIL13TR01799AA 19

32. Connect the pipes to the power steering cylinder (1) and (2). Connect the power supply to the control valve (3). Refit the fixture (4).

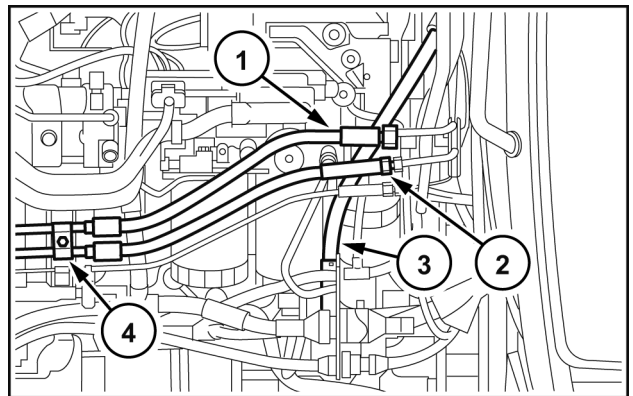

WLAPL4S10C125A 20

33. If it was necessary to remove the DPF support, proceed as follows:

- 1 – Mount the upper support (1) on the right-hand one (2) with the three Allen screws.
- 2 – Mount the left-hand support (5) securing it to the engine with the three lower screws.
- 3 – Mount the assembly of the supports (1) and (2) to the engine with the four screws in position (3), respecting the reference marks made when dismantling.
- 4 – Secure the support (5) to the support (1) with the two upper screws with the two adjustment bushings.
- 5 – Mount the support (4) to the engine with the two lower screws. Fasten the three left-hand screws to the support (5) and with the two upper screws to the support (1).

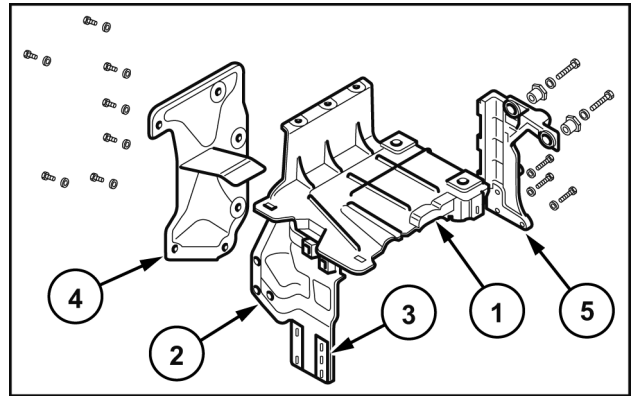

WLAPL4S10C124A 21

34. Refit the DPF filter assembly. Return the entire unit into position. Fasten the four fixing screws of the assembly to the cradle.

Observation:

If, after refitting the DPF filter, you find a slight misalignment with the axis of the turbine, it is possible to make a correction. On the two screws fixing the filter to the cradle there are two threaded bushings (2) held in position by a grub screw (1).

Loosen the grub screw with an Allen key. Tighten or loosen the bushing by the amount necessary to correct the misalignment. Retighten the grub screw. Secure the support.

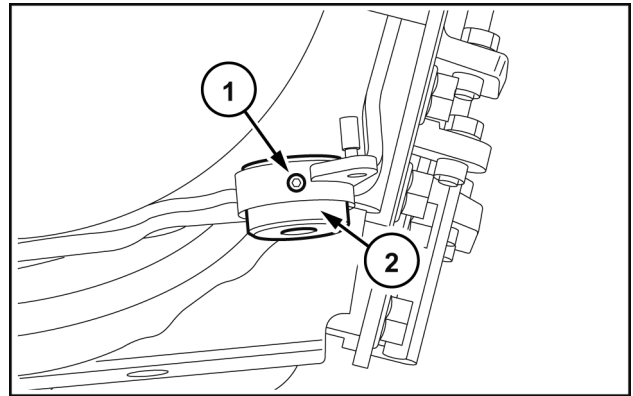

WLAPL4S10C146A 22

35. Tighten the clamp (4). Fix the filter to the bottom cradle using the four screws (5). Reconnect all of the sensors.

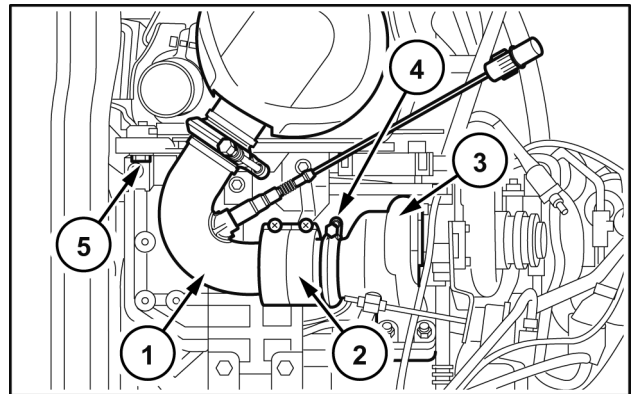

WLAPL4S10C122A 23

**ATTENTION:** The filter outlet union DPF (1) at its terminal (2) has a decoupler that responds to temperature variations by changing length.

A small misalignment of the axis of the decoupler with respect to the axis of the turbine outlet (3) would produce an adjustment that would no longer be lengthwise, in line with the direction of the tractor, but abnormal transversal adjustment that would impair its durability.

36. Refit the hood support of the air filter bracket (1).

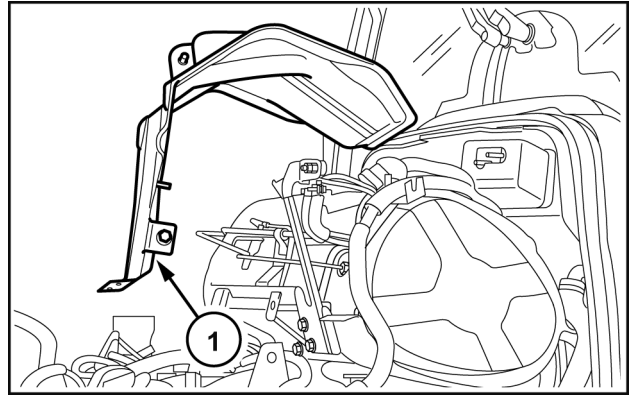

WLAPL4S10C121A 24

37. Reassemble the air filter unit (4) and the respective support (3). Fix the screws on the filter bracket and on the supply duct on the radiator. Refit the sleeve connected to the turbine (2), and the oil vapor duct (1).

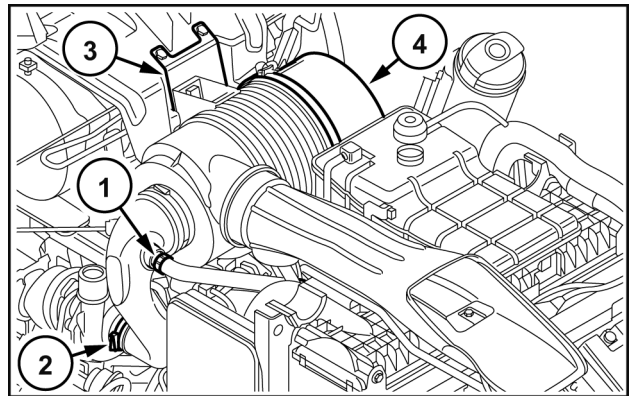

WLAPL4S10C120A 25

38. Refit the two pipes (2) and (3) to the radiator inter-cooler. Tighten the respective clamps (1).

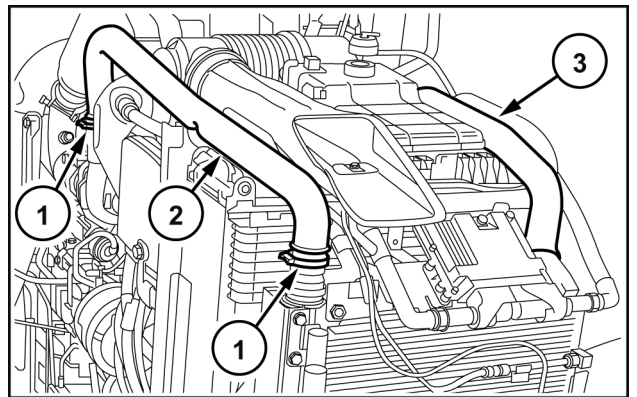

WLAPL4S10C119A 26

39. Refit the exhaust pipe (3). Tighten the relevant retaining clamps (1) and (2).

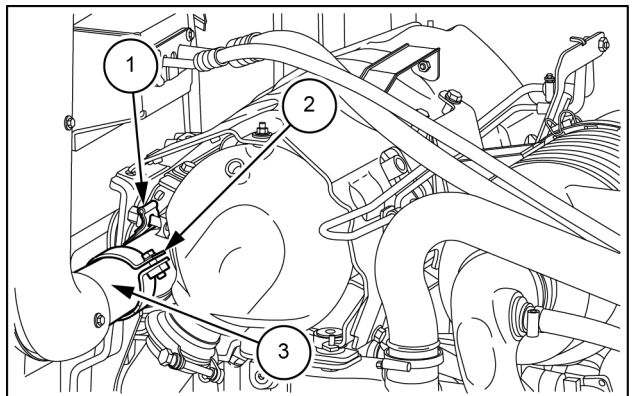

MOIL13TR01798AA 27

40. Refit the transmission oil drain plug **(1)**. Refill with oil using a pump.

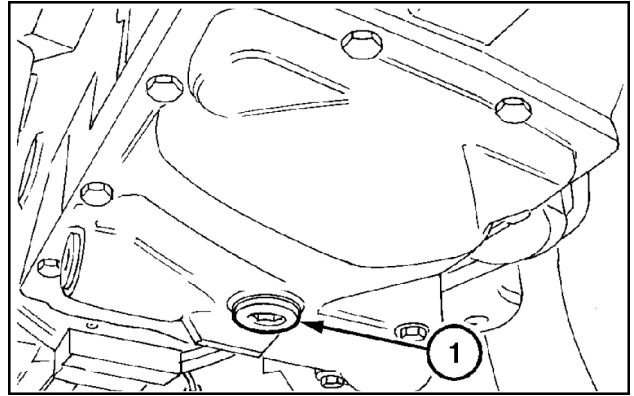

MOIL13TR00197AA 28

41. Refit the drive shaft together with the central support **(1)** and the retaining bolts. Insert the shim. Adjust the shaft end play.

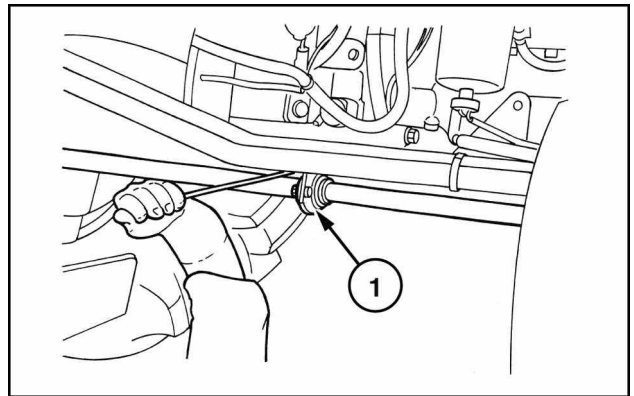

WLAPL4S10C115AA 29

42. Refit the guard of the front axle control shaft **(1)**. Tighten the front, central, and rear retaining bolts.

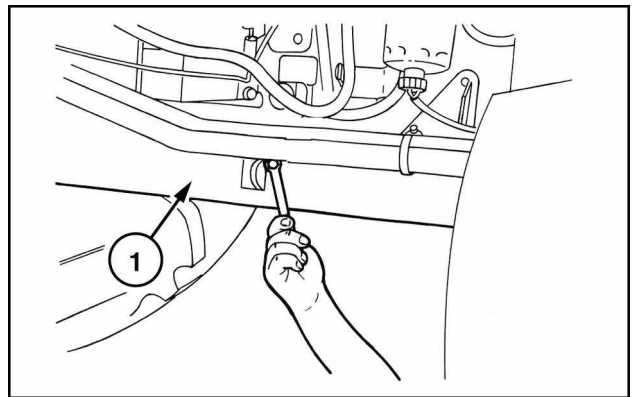

WLAPL4S10C112AA 30

43. Using a hydraulic jack, raise the rear of the tractor. Remove the mechanical jack stand under the left-hand reduction gear. Put the wheel back into position. Fit the retaining nuts with a pneumatic gun.

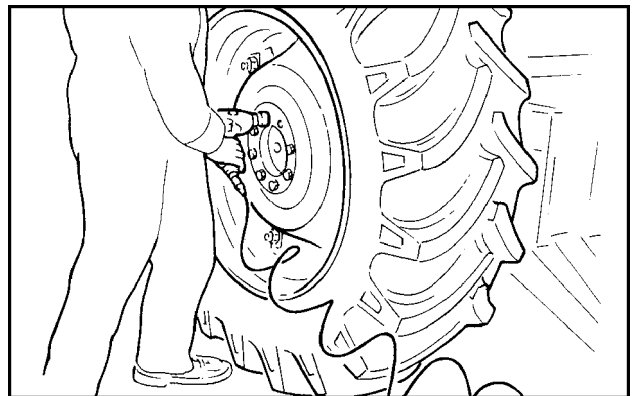

WLAPL4S10C110A 31

44. Reconnect the air-conditioning lines (3) and the sensor (2) to the condenser (1). Fix them with clamps and brackets.

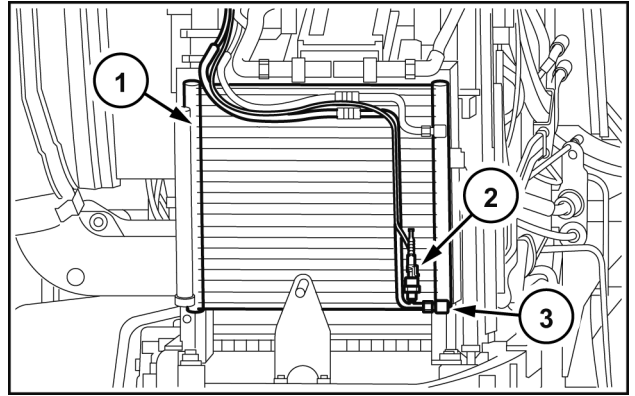

WLAPL4S10C107A 32

45. Reconnect the air-conditioning lines (1) and (2) on the compressor. Secure the lines with clamps and brackets.
46. Top up the air-conditioning system with refrigerant using the specific controller **380000315**.

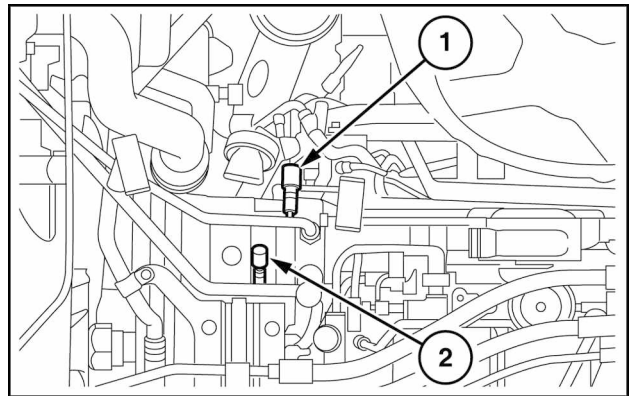

WLAPL4S10C106AA 33

47. Refit the front wheel fenders (2), if applicable. Tighten the respective fixtures (1).

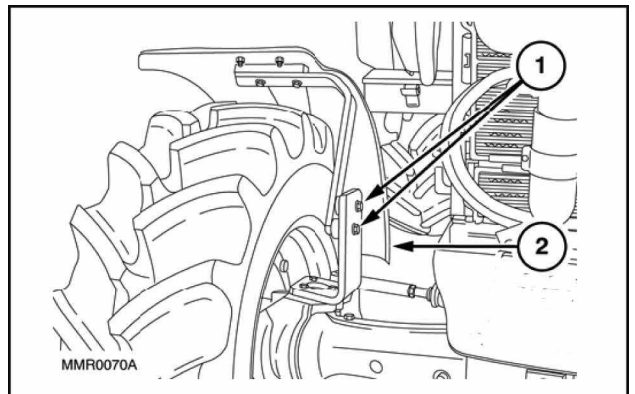

MMR0070A

WLAPL4S10C104A 34

48. Re-install the tank, as described in **Fuel tank - Install (10.216)**.
49. Re-install the battery, as described in **Battery - Install (55.302)**.
50. Refit the engine hood, as indicated in **Hood - Install (90.100)**.



# Index

---

## Engine - 10

### Engine and crankcase - 001

|                            |    |
|----------------------------|----|
| Engine - Install (*) ..... | 23 |
| Engine - Install (*) ..... | 33 |
| Engine - Remove (*) .....  | 3  |
| Engine - Remove (*) .....  | 13 |

(\*) See content for specific models



## **Engine - 10**

### **Fuel tanks - 216**

**T4.105 less cab, with mechanical or power shuttle transmission [ZxJT0xxxx], T4.105 with cab, with mechanical or power shuttle transmission [ZxJT0xxxx], T4.105 with cab, with hi-lo transmission [ZxJT0xxxx], T4.105 with cab, with hi-lo transmission, with Supersteer™ front axle [ZxJT0xxxx], T4.105 less cab, with hi-lo transmission [ZxJT0xxxx], T4.115 less cab, with mechanical or power shuttle transmission [ZxJT0xxxx], T4.115 with cab, with mechanical or power shuttle transmission [ZxJT0xxxx], T4.115 less cab, with hi-lo transmission [ZxJT0xxxx], T4.115 with cab, with hi-lo transmission [ZxJT0xxxx], T4.115 with cab, with hi-lo transmission, with Supersteer™ front axle [ZxJT0xxxx], T4.75 less cab, with mechanical or power shuttle transmission [ZxJT0xxxx], T4.75 with cab, with mechanical or power shuttle transmission [ZxJT0xxxx], T4.75 with cab, with hi-lo transmission [ZxJT0xxxx], T4.75 with cab, with hi-lo transmission, with Supersteer™ front axle [ZxJT0xxxx], T4.75 less cab, with hi-lo transmission [ZxJT0xxxx], T4.85 less cab, with mechanical or power shuttle transmission [ZxJT0xxxx], T4.85 with cab, with mechanical or power shuttle transmission [ZxJT0xxxx], T4.85**



**with cab, with hi-lo transmission [ZxJT0xxxx], T4.85 with cab, with hi-lo transmission, with Supersteer™ front axle [ZxJT0xxxx], T4.85 less cab, with hi-lo transmission [ZxJT0xxxx], T4.95 less cab, with mechanical or power shuttle transmission [ZxJT0xxxx], T4.95 with cab, with mechanical or power shuttle transmission [ZxJT0xxxx], T4.95 with cab, with hi-lo transmission [ZxJT0xxxx], T4.95 with cab, with hi-lo transmission, with Supersteer™ front axle [ZxJT0xxxx], T4.95 less cab, with hi-lo transmission [ZxJT0xxxx]**



# Contents

---

## Engine - 10

## Fuel tanks - 216

### SERVICE

|               |   |
|---------------|---|
| Fuel tank     |   |
| Remove .....  | 3 |
| Install ..... | 5 |

## Fuel tank - Remove

### **⚠ DANGER**

#### **Heavy objects!**

**Lift and handle all heavy components using lifting equipment with adequate capacity. Always support units or parts with suitable slings or hooks. Make sure the work area is clear of all bystanders. Failure to comply will result in death or serious injury.**

D0076A

1. Using a hydraulic jack, remove the left-hand wheel (1). Place a suitable jack stand under the axle.

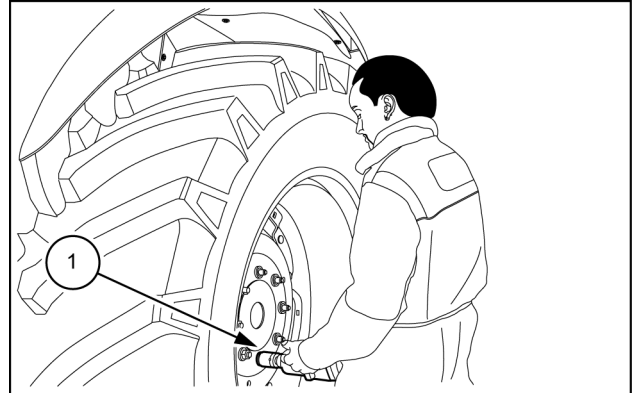

MOIL12TR00737AA 1

2. Loosen the relative bolts (1). Remove the ladder (2).

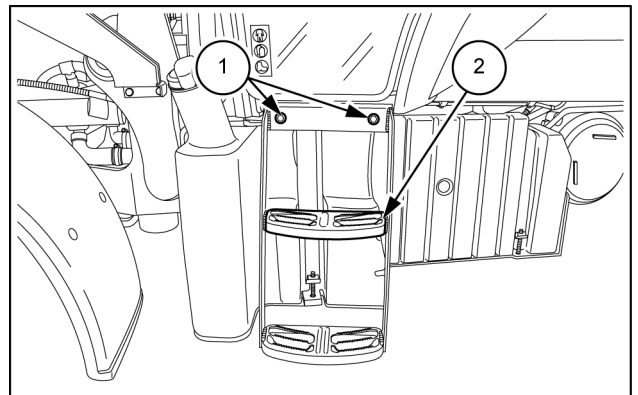

MOIL12TR00539AA 2

3. Drain the fuel tank (1).
4. Place a jack under the tank. Loosen the screws that secure the retaining straps (2) and (3). Remove the retaining straps. Partially pull out the tank.

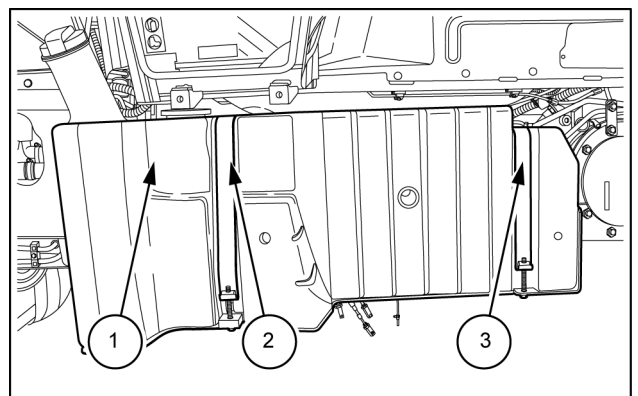

MOIL12TR00540AA 3

5. Disconnect the electrical connection **(1)**.
6. Label and disconnect the fuel suction and return lines **(2)**.

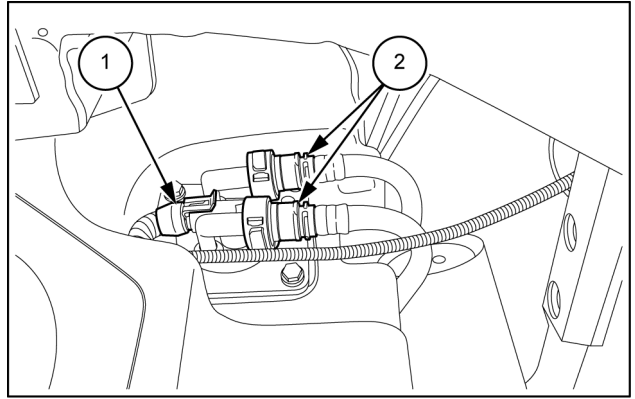

MOIL12TR00541AA 4

7. Remove the bracket **(1)** that secures the fuel intake line and the fuel return line to the tank. Then remove the tank.

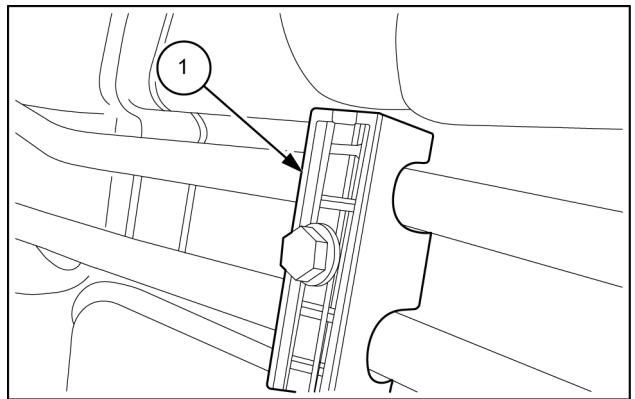

MOIL12TR00542AA 5

## Fuel tank - Install

### **⚠ DANGER**

**Heavy objects!**

**Lift and handle all heavy components using lifting equipment with adequate capacity. Always support units or parts with suitable slings or hooks. Make sure the work area is clear of all bystanders.**

**Failure to comply will result in death or serious injury.**

D0076A

1. Use a jack to hold the tank (1) in position. Tighten the retaining straps (2) and (3).

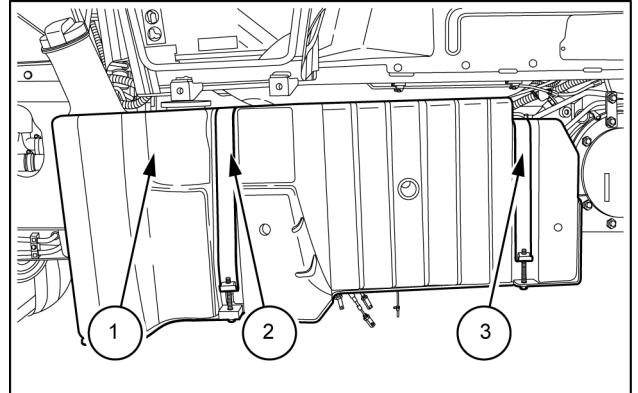

MOIL12TR00540AA 1

2. Connect the electrical connection (1).
3. Connect the fuel suction and return pipes (2).

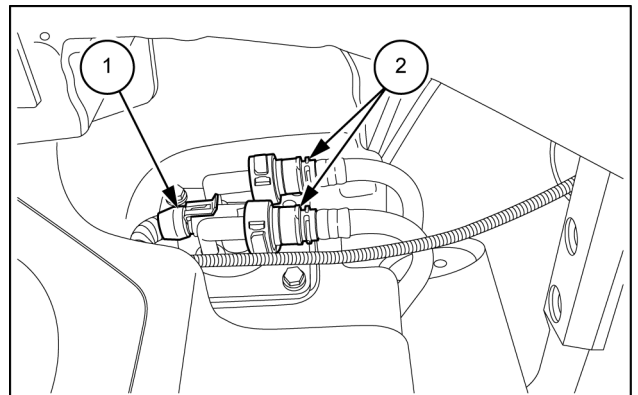

MOIL12TR00541AA 2

4. Refit the bracket (1) securing the fuel suction and return pipes to the tank.

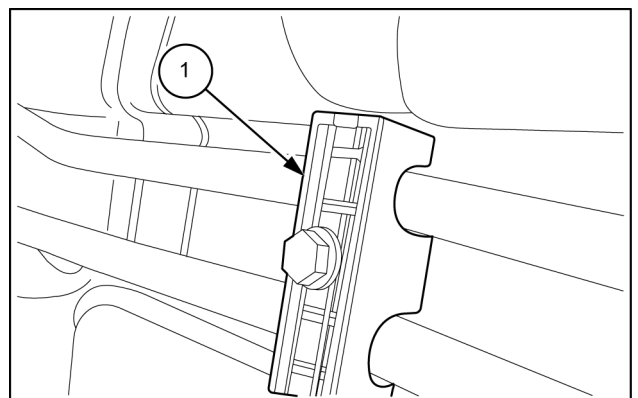

MOIL12TR00542AA 3



This as a preview PDF file from [best-manuals.com](http://best-manuals.com)



Download full PDF manual at [best-manuals.com](http://best-manuals.com)