

SERVICE MANUAL

T7.230 / T7.245 / T7.260

T7.230 AutoCommand™ / T7.245 AutoCommand™

T7.260 AutoCommand™ / T7.270 AutoCommand™

Stage IV

Tractor

Part number 47936454

English

November 2015





SERVICE MANUAL

**T7.230 AutoCommand™, T7.230, T7.245 AutoCommand™, T7.245, T7.260
AutoCommand™, T7.260, T7.270 AutoCommand™**

Link Product / Engine

Product	Market Product	Engine
T7.230 AutoCommand™	Europe	F4DFE613K*B006
T7.245 AutoCommand™	Europe	F4DFE613J*B006
T7.260 AutoCommand™	Europe	F4DFE613H*B003
T7.270 AutoCommand™	Europe	F4DFE613B*B006
T7.230	Europe	F4DFE613K*B006
T7.245	Europe	F4DFE613J*B006
T7.260	Europe	F4DFE613H*B003

Contents

INTRODUCTION

Engine	10
[10.001] Engine and crankcase	10.1
[10.216] Fuel tanks	10.2
[10.218] Fuel injection system.....	10.3
[10.254] Intake and exhaust manifolds and muffler	10.4
[10.500] Selective Catalytic Reduction (SCR) exhaust treatment.....	10.5
[10.400] Engine cooling system	10.6
[10.414] Fan and drive	10.7
[10.408] Oil cooler and lines.....	10.8
[10.101] Cylinder heads	10.9
Clutch	18
[18.112] Slip clutch or flywheel damper	18.1
Transmission	21
[21.113] Powershift transmission	21.1
[21.155] Powershift transmission internal components.....	21.2
[21.160] Creeper	21.3
[21.166] Overdrive.....	21.4
[21.504] Continuously Variable Transmission (CVT)	21.5
[21.505] Continuously Variable Transmission (CVT) external controls.....	21.6
[21.507] Continuously Variable Transmission (CVT) internal components.....	21.7
[21.506] Continuously Variable Transmission (CVT) lubrication system	21.8
[21.109] Transmission cooler and lines.....	21.9
Four-Wheel Drive (4WD) system	23
[23.202] Electro-hydraulic control	23.1
[23.314] Drive shaft.....	23.2

Front axle system	25
[25.100] Powered front axle	25.1
[25.102] Front bevel gear set and differential	25.2
[25.108] Final drive hub, steering knuckles, and shafts	25.3
[25.122] Axle suspension control	25.4
Rear axle system.....	27
[27.100] Powered rear axle.....	27.1
[27.106] Rear bevel gear set and differential.....	27.2
[27.120] Planetary and final drives	27.3
[27.126] Spur gear and final drives.....	27.4
Power Take-Off (PTO).....	31
[31.101] Rear mechanical control	31.1
[31.104] Rear electro-hydraulic control.....	31.2
[31.114] Two-speed rear Power Take-Off (PTO)	31.3
[31.116] Three-speed rear Power Take-Off (PTO)	31.4
[31.119] Four-speed rear Power Take-Off (PTO).....	31.5
[31.146] Front Power Take-Off (PTO)	31.6
Brakes and controls	33
[33.202] Hydraulic service brakes	33.1
[33.110] Parking brake or parking lock	33.2
[33.220] Trailer brake hydraulic control.....	33.3
[33.224] Trailer brake pneumatic control	33.4
[33.350] Anti-lock Brake System (ABS)	33.5
Hydraulic systems.....	35
[35.000] Hydraulic systems.....	35.1
[35.300] Reservoir, cooler, and filters.....	35.2
[35.106] Variable displacement pump	35.3
[35.102] Pump control valves.....	35.4

[35.105] Charge pump.....	35.5
[35.230] Priority valves	35.6
[35.322] Regulated/Low pressure system.....	35.7
[35.204] Remote control valves	35.8
[35.220] Auxiliary hydraulic pump	35.9
[35.114] Three-point hitch control valve	35.10
[35.160] Front hitch controls and lines	35.11
[35.162] Front hitch cylinders and lines	35.12
Pneumatic system	36
[36.100] Pneumatic system.....	36.1
Hitches, drawbars, and implement couplings.....	37
[37.120] Rear three-point hitch linkage.....	37.1
[37.110] Rear three-point hitch	37.2
[37.162] Front hitch.....	37.3
[37.106] Automatic pickup hitch	37.4
Frames and ballasting	39
[39.100] Frame	39.1
Steering.....	41
[41.101] Steering control	41.1
[41.106] Tie rods.....	41.2
[41.200] Hydraulic control components.....	41.3
[41.216] Cylinders	41.4
[41.432] Autoguidance steering	41.5
Wheels.....	44
[44.511] Front wheels.....	44.1
[44.520] Rear wheels.....	44.2
Cab climate control	50

[50.100] Heating	50.1
[50.104] Ventilation	50.2
[50.200] Air conditioning	50.3
Electrical systems	55
[55.000] Electrical system	55.1
[55.100] Harnesses and connectors	55.2
[55.640] Electronic modules	55.3
[55.015] Engine control system	55.4
[55.301] Alternator	55.5
[55.302] Battery	55.6
[55.011] Fuel tank system	55.7
[55.010] Fuel injection system	55.8
[55.988] Selective Catalytic Reduction (SCR) electrical system	55.9
[55.513] Cab transmission controls	55.10
[55.020] Transmission speed sensors	55.11
[55.021] Transmission pressure sensors	55.12
[55.022] Transmission temperature sensors	55.13
[55.023] Transmission position sensors	55.14
[55.610] Ground speed control	55.15
[55.045] Front axle control system	55.16
[55.048] Rear Power Take-Off (PTO) control system	55.17
[55.049] Front Power Take-Off (PTO) control system	55.18
[55.031] Parking brake electrical system	55.19
[55.035] Remote control valve electric control	55.20
[55.051] Cab Heating, Ventilation, and Air-Conditioning (HVAC) controls	55.21
[55.050] Heating, Ventilation, and Air-Conditioning (HVAC) control system	55.22
[55.047] Steering control system	55.23
[55.523] Cab hitch controls	55.24
[55.130] Rear three-point hitch electronic control system	55.25

[55.911] Global Positioning System (GPS)	55.26
[55.408] Warning indicators, alarms, and instruments	55.27
[55.350] Anti-lock Brake System (ABS) electrical system	55.28
[55.512] Cab controls	55.29
[55.030] Service brake electrical system	55.30
[55.510] Cab or platform harnesses and connectors	55.31
[55.DTC] FAULT CODES	55.32
Platform, cab, bodywork, and decals	90
[90.100] Engine hood and panels	90.1
[90.150] Cab	90.2



INTRODUCTION

Contents

INTRODUCTION

Safety rules	3
Safety rules - Ecology and the environment	4
Basic instructions - Important notice regarding equipment servicing	5
Basic instructions - Shop and assembly	6
Torque - Minimum tightening torques for normal assembly	8
Torque - Standard torque data for hydraulics	13
Hydraulic contamination	15
Capacities	16
Consumables	17

Safety rules

Personal safety





This is the safety alert symbol. It is used to alert you to potential personal injury hazards. Obey all safety messages that follow this symbol to avoid possible death or injury.

Throughout this manual you will find the signal words DANGER, WARNING, and CAUTION followed by special instructions. These precautions are intended for the personal safety of you and those working with you.

Read and understand all the safety messages in this manual before you operate or service the machine.

 DANGER indicates a hazardous situation that, if not avoided, will result in death or serious injury.

 WARNING indicates a hazardous situation that, if not avoided, could result in death or serious injury.

 CAUTION indicates a hazardous situation that, if not avoided, could result in minor or moderate injury.

FAILURE TO FOLLOW DANGER, WARNING, AND CAUTION MESSAGES COULD RESULT IN DEATH OR SERIOUS INJURY.

Machine safety

NOTICE: Notice indicates a situation that, if not avoided, could result in machine or property damage.

Throughout this manual you will find the signal word Notice followed by special instructions to prevent machine or property damage. The word Notice is used to address practices not related to personal safety.

Information

NOTE: Note indicates additional information that clarifies steps, procedures, or other information in this manual.

Throughout this manual you will find the word Note followed by additional information about a step, procedure, or other information in the manual. The word Note is not intended to address personal safety or property damage.

Safety rules - Ecology and the environment

Soil, air, and water quality is important for all industries and life in general. When legislation does not yet rule the treatment of some of the substances that advanced technology requires, sound judgment should govern the use and disposal of products of a chemical and petrochemical nature.

Familiarize yourself with the relative legislation applicable to your country, and make sure that you understand this legislation. Where no legislation exists, obtain information from suppliers of oils, filters, batteries, fuels, anti-freeze, cleaning agents, etc., with regard to the effect of these substances on man and nature and how to safely store, use, and dispose of these substances.

Helpful hints

- Avoid the use of cans or other inappropriate pressurized fuel delivery systems to fill tanks. Such delivery systems may cause considerable spillage.
- In general, avoid skin contact with all fuels, oils, acids, solvents, etc. Most of these products contain substances that may be harmful to your health.
- Modern oils contain additives. Do not burn contaminated fuels and or waste oils in ordinary heating systems.
- Avoid spillage when you drain fluids such as used engine coolant mixtures, engine oil, hydraulic fluid, brake fluid, etc. Do not mix drained brake fluids or fuels with lubricants. Store all drained fluids safely until you can dispose of the fluids in a proper way that complies with all local legislation and available resources.
- Do not allow coolant mixtures to get into the soil. Collect and dispose of coolant mixtures properly.
- The air-conditioning system contains gases that should not be released into the atmosphere. Consult an air-conditioning specialist or use a special extractor to recharge the system properly.
- Repair any leaks or defects in the engine cooling system or hydraulic system immediately.
- Do not increase the pressure in a pressurized circuit as this may lead to a component failure.
- Protect hoses during welding. Penetrating weld splatter may burn a hole or weaken hoses, allowing the loss of oils, coolant, etc.

Battery recycling

Batteries and electric accumulators contain several substances that can have a harmful effect on the environment if the batteries are not properly recycled after use. Improper disposal of batteries can contaminate the soil, groundwater, and waterways. NEW HOLLAND strongly recommends that you return all used batteries to a NEW HOLLAND dealer, who will dispose of the used batteries or recycle the used batteries properly. In some countries, this is a legal requirement.



Mandatory battery recycling

NOTE: *The following requirements are mandatory in Brazil.*

Batteries are made of lead plates and a sulfuric acid solution. Because batteries contain heavy metals such as lead, CONAMA Resolution 401/2008 requires you to return all used batteries to the battery dealer when you replace any batteries. Do not dispose of batteries in your household garbage.

Points of sale are obliged to:

- Accept the return of your used batteries
- Store the returned batteries in a suitable location
- Send the returned batteries to the battery manufacturer for recycling

Basic instructions - Important notice regarding equipment servicing

All repair and maintenance work listed in this manual must be carried out only by qualified dealership personnel, strictly complying with the instructions given, and using, whenever possible, the special tools.

Anyone who performs repair and maintenance operations without complying with the procedures provided herein shall be responsible for any subsequent damages.

The manufacturer and all the organizations of its distribution chain, including - without limitation - national, regional, or local dealers, reject any responsibility for damages caused by parts and/or components not approved by the manufacturer, including those used for the servicing or repair of the product manufactured or marketed by the manufacturer. In any case, no warranty is given or attributed on the product manufactured or marketed by the manufacturer in case of damages caused by parts and/or components not approved by the manufacturer.

The information in this manual is up-to-date at the date of the publication. It is the policy of the manufacturer for continuous improvement. Some information could not be updated due to modifications of a technical or commercial type, or changes to the laws and regulations of different countries.

In case of questions, refer to your NEW HOLLAND Sales and Service Networks.

Basic instructions - Shop and assembly

Shimming

For each adjustment operation, select adjusting shims and measure the adjusting shims individually using a micrometer, then add up the recorded values. Do not rely on measuring the entire shimming set, which may be incorrect, or the rated value shown on each shim.

Rotating shaft seals

For correct rotating shaft seal installation, proceed as follows:

1. Before assembly, allow the seal to soak in the oil it will be sealing for at least thirty minutes.
2. Thoroughly clean the shaft and check that the working surface on the shaft is not damaged.
3. Position the sealing lip facing the fluid.

NOTE: *With hydrodynamic lips, take into consideration the shaft rotation direction and position the grooves so that they will move the fluid towards the inner side of the seal.*

4. Coat the sealing lip with a thin layer of lubricant (use oil rather than grease). Fill the gap between the sealing lip and the dust lip on double lip seals with grease.
5. Insert the seal in its seat and press down using a flat punch or seal installation tool. Do not tap the seal with a hammer or mallet.
6. While you insert the seal, check that the seal is perpendicular to the seat. When the seal settles, make sure that the seal makes contact with the thrust element, if required.
7. To prevent damage to the seal lip on the shaft, position a protective guard during installation operations.

O-ring seals

Lubricate the O-ring seals before you insert them in the seats. This will prevent the O-ring seals from overturning and twisting, which would jeopardize sealing efficiency.

Sealing compounds

Apply a sealing compound on the mating surfaces when specified by the procedure. Before you apply the sealing compound, prepare the surfaces as directed by the product container.

Spare parts

Only use CNH Original Parts or NEW HOLLAND Original Parts.

Only genuine spare parts guarantee the same quality, duration, and safety as original parts, as they are the same parts that are assembled during standard production. Only CNH Original Parts or NEW HOLLAND Original Parts can offer this guarantee.

When ordering spare parts, always provide the following information:

- Machine model (commercial name) and Product Identification Number (PIN)
- Part number of the ordered part, which can be found in the parts catalog

Protecting the electronic and/or electrical systems during charging and welding

To avoid damage to the electronic and/or electrical systems, always observe the following practices:

1. Never make or break any of the charging circuit connections when the engine is running, including the battery connections.
2. Never short any of the charging components to ground.
3. Always disconnect the ground cable from the battery before arc welding on the machine or on any machine attachment.
 - Position the welder ground clamp as close to the welding area as possible.
 - If you weld in close proximity to a computer module, then you should remove the module from the machine.
 - Never allow welding cables to lie on, near, or across any electrical wiring or electronic component while you weld.
4. Always disconnect the negative cable from the battery when charging the battery in the machine with a battery charger.

NOTICE: *If you must weld on the unit, you must disconnect the battery ground cable from the machine battery. The electronic monitoring system and charging system will be damaged if this is not done.*

5. Remove the battery ground cable. Reconnect the cable when you complete welding.

⚠ WARNING

Battery acid causes burns. Batteries contain sulfuric acid. Avoid contact with skin, eyes or clothing. Antidote (external): Flush with water. Antidote (eyes): flush with water for 15 minutes and seek medical attention immediately. Antidote (internal): Drink large quantities of water or milk. Do not induce vomiting. Seek medical attention immediately. Failure to comply could result in death or serious injury.

W0111A

Special tools

The special tools that NEW HOLLAND suggests and illustrate in this manual have been specifically researched and designed for use with NEW HOLLAND machines. The special tools are essential for reliable repair operations. The special tools are accurately built and rigorously tested to offer efficient and long-lasting operation.

By using these tools, repair personnel will benefit from:

- Operating in optimal technical conditions
- Obtaining the best results
- Saving time and effort
- Working in safe conditions

Torque - Minimum tightening torques for normal assembly

METRIC NON-FLANGED HARDWARE

NOM. SIZE	CLASS 8.8 BOLT and CLASS 8 NUT		CLASS 10.9 BOLT and CLASS 10 NUT		LOCKNUT CL.8 W/CL8.8 BOLT	LOCKNUT CL.10 W/CL10.9 BOLT
	UNPLATED	PLATED W/ZnCr	UNPLATED	PLATED W/ZnCr		
M4	2.2 N·m (19 lb in)	2.9 N·m (26 lb in)	3.2 N·m (28 lb in)	4.2 N·m (37 lb in)	2 N·m (18 lb in)	2.9 N·m (26 lb in)
M5	4.5 N·m (40 lb in)	5.9 N·m (52 lb in)	6.4 N·m (57 lb in)	8.5 N·m (75 lb in)	4 N·m (36 lb in)	5.8 N·m (51 lb in)
M6	7.5 N·m (66 lb in)	10 N·m (89 lb in)	11 N·m (96 lb in)	15 N·m (128 lb in)	6.8 N·m (60 lb in)	10 N·m (89 lb in)
M8	18 N·m (163 lb in)	25 N·m (217 lb in)	26 N·m (234 lb in)	35 N·m (311 lb in)	17 N·m (151 lb in)	24 N·m (212 lb in)
M10	37 N·m (27 lb ft)	49 N·m (36 lb ft)	52 N·m (38 lb ft)	70 N·m (51 lb ft)	33 N·m (25 lb ft)	48 N·m (35 lb ft)
M12	64 N·m (47 lb ft)	85 N·m (63 lb ft)	91 N·m (67 lb ft)	121 N·m (90 lb ft)	58 N·m (43 lb ft)	83 N·m (61 lb ft)
M16	158 N·m (116 lb ft)	210 N·m (155 lb ft)	225 N·m (166 lb ft)	301 N·m (222 lb ft)	143 N·m (106 lb ft)	205 N·m (151 lb ft)
M20	319 N·m (235 lb ft)	425 N·m (313 lb ft)	440 N·m (325 lb ft)	587 N·m (433 lb ft)	290 N·m (214 lb ft)	400 N·m (295 lb ft)
M24	551 N·m (410 lb ft)	735 N·m (500 lb ft)	762 N·m (560 lb ft)	1016 N·m (750 lb ft)	501 N·m (370 lb ft)	693 N·m (510 lb ft)

NOTE: M4 through M8 hardware torque specifications are shown in pound-inches. M10 through M24 hardware torque specifications are shown in pound-feet.

METRIC FLANGED HARDWARE

NOM. SIZE	CLASS 8.8 BOLT and CLASS 8 NUT		CLASS 10.9 BOLT and CLASS 10 NUT		LOCKNUT CL.8 W/CL8.8 BOLT	LOCKNUT CL.10 W/CL10.9 BOLT
	UNPLATED	PLATED W/ZnCr	UNPLATED	PLATED W/ZnCr		
M4	2.4 N·m (21 lb in)	3.2 N·m (28 lb in)	3.5 N·m (31 lb in)	4.6 N·m (41 lb in)	2.2 N·m (19 lb in)	3.1 N·m (27 lb in)
M5	4.9 N·m (43 lb in)	6.5 N·m (58 lb in)	7.0 N·m (62 lb in)	9.4 N·m (83 lb in)	4.4 N·m (39 lb in)	6.4 N·m (57 lb in)
M6	8.3 N·m (73 lb in)	11 N·m (96 lb in)	12 N·m (105 lb in)	16 N·m (141 lb in)	7.5 N·m (66 lb in)	11 N·m (96 lb in)
M8	20 N·m (179 lb in)	27 N·m (240 lb in)	29 N·m (257 lb in)	39 N·m (343 lb in)	18 N·m (163 lb in)	27 N·m (240 lb in)
M10	40 N·m (30 lb ft)	54 N·m (40 lb ft)	57 N·m (42 lb ft)	77 N·m (56 lb ft)	37 N·m (27 lb ft)	53 N·m (39 lb ft)
M12	70 N·m (52 lb ft)	93 N·m (69 lb ft)	100 N·m (74 lb ft)	134 N·m (98 lb ft)	63 N·m (47 lb ft)	91 N·m (67 lb ft)
M16	174 N·m (128 lb ft)	231 N·m (171 lb ft)	248 N·m (183 lb ft)	331 N·m (244 lb ft)	158 N·m (116 lb ft)	226 N·m (167 lb ft)
M20	350 N·m (259 lb ft)	467 N·m (345 lb ft)	484 N·m (357 lb ft)	645 N·m (476 lb ft)	318 N·m (235 lb ft)	440 N·m (325 lb ft)
M24	607 N·m (447 lb ft)	809 N·m (597 lb ft)	838 N·m (618 lb ft)	1118 N·m (824 lb ft)	552 N·m (407 lb ft)	

IDENTIFICATION

Metric Hex head and carriage bolts, classes 5.6 and up

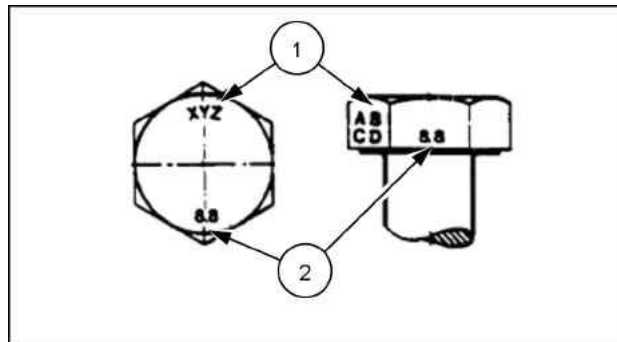

20083680 1

1. Manufacturer's Identification
2. Property Class

Metric Hex nuts and locknuts, classes 05 and up

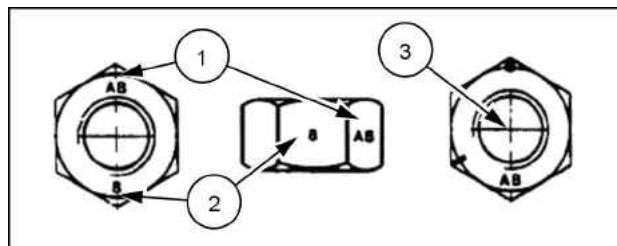

20083681 2

1. Manufacturer's Identification
2. Property Class
3. Clock Marking of Property Class and Manufacturer's Identification (Optional), i.e. marks **60 °** apart indicate Class 10 properties, and marks **120 °** apart indicate Class 8.

INCH NON-FLANGED HARDWARE

NOMINAL SIZE	SAE GRADE 5 BOLT and NUT		SAE GRADE 8 BOLT and NUT		LOCKNUT GrB W/ Gr5 BOLT	LOCKNUT GrC W/ Gr8 BOLT
	UN-PLATED or PLATED SILVER	PLATED W/ZnCr GOLD	UN-PLATED or PLATED SILVER	PLATED W/ZnCr GOLD		
1/4	8 N·m (71 lb in)	11 N·m (97 lb in)	12 N·m (106 lb in)	16 N·m (142 lb in)	8.5 N·m (75 lb in)	12.2 N·m (109 lb in)
5/16	17 N·m (150 lb in)	23 N·m (204 lb in)	24 N·m (212 lb in)	32 N·m (283 lb in)	17.5 N·m (155 lb in)	25 N·m (220 lb in)
3/8	30 N·m (22 lb ft)	40 N·m (30 lb ft)	43 N·m (31 lb ft)	57 N·m (42 lb ft)	31 N·m (23 lb ft)	44 N·m (33 lb ft)
7/16	48 N·m (36 lb ft)	65 N·m (48 lb ft)	68 N·m (50 lb ft)	91 N·m (67 lb ft)	50 N·m (37 lb ft)	71 N·m (53 lb ft)
1/2	74 N·m (54 lb ft)	98 N·m (73 lb ft)	104 N·m (77 lb ft)	139 N·m (103 lb ft)	76 N·m (56 lb ft)	108 N·m (80 lb ft)
9/16	107 N·m (79 lb ft)	142 N·m (105 lb ft)	150 N·m (111 lb ft)	201 N·m (148 lb ft)	111 N·m (82 lb ft)	156 N·m (115 lb ft)
5/8	147 N·m (108 lb ft)	196 N·m (145 lb ft)	208 N·m (153 lb ft)	277 N·m (204 lb ft)	153 N·m (113 lb ft)	215 N·m (159 lb ft)
3/4	261 N·m (193 lb ft)	348 N·m (257 lb ft)	369 N·m (272 lb ft)	491 N·m (362 lb ft)	271 N·m (200 lb ft)	383 N·m (282 lb ft)
7/8	420 N·m (310 lb ft)	561 N·m (413 lb ft)	594 N·m (438 lb ft)	791 N·m (584 lb ft)	437 N·m (323 lb ft)	617 N·m (455 lb ft)
1	630 N·m (465 lb ft)	841 N·m (620 lb ft)	890 N·m (656 lb ft)	1187 N·m (875 lb ft)	654 N·m (483 lb ft)	924 N·m (681 lb ft)

NOTE: For Imperial Units, *1/4 in* and *5/16 in* hardware torque specifications are shown in pound-inches. *3/8 in* through *1 in* hardware torque specifications are shown in pound-feet.

INCH FLANGED HARDWARE

NOM- INAL SIZE	SAE GRADE 5 BOLT and NUT		SAE GRADE 8 BOLT and NUT		LOCKNUT GrF W/ Gr5 BOLT	LOCKNUT GrG W/ Gr8 BOLT
	UNPLATED or PLATED SILVER	PLATED W/ZnCr GOLD	UNPLATED or PLATED SILVER	PLATED W/ZnCr GOLD		
1/4	9 N·m (80 lb in)	12 N·m (106 lb in)	13 N·m (115 lb in)	17 N·m (150 lb in)	8 N·m (71 lb in)	12 N·m (106 lb in)
5/16	19 N·m (168 lb in)	25 N·m (221 lb in)	26 N·m (230 lb in)	35 N·m (310 lb in)	17 N·m (150 lb in)	24 N·m (212 lb in)
3/8	33 N·m (25 lb ft)	44 N·m (33 lb ft)	47 N·m (35 lb ft)	63 N·m (46 lb ft)	30 N·m (22 lb ft)	43 N·m (32 lb ft)
7/16	53 N·m (39 lb ft)	71 N·m (52 lb ft)	75 N·m (55 lb ft)	100 N·m (74 lb ft)	48 N·m (35 lb ft)	68 N·m (50 lb ft)
1/2	81 N·m (60 lb ft)	108 N·m (80 lb ft)	115 N·m (85 lb ft)	153 N·m (113 lb ft)	74 N·m (55 lb ft)	104 N·m (77 lb ft)
9/16	117 N·m (86 lb ft)	156 N·m (115 lb ft)	165 N·m (122 lb ft)	221 N·m (163 lb ft)	106 N·m (78 lb ft)	157 N·m (116 lb ft)
5/8	162 N·m (119 lb ft)	216 N·m (159 lb ft)	228 N·m (168 lb ft)	304 N·m (225 lb ft)	147 N·m (108 lb ft)	207 N·m (153 lb ft)
3/4	287 N·m (212 lb ft)	383 N·m (282 lb ft)	405 N·m (299 lb ft)	541 N·m (399 lb ft)	261 N·m (193 lb ft)	369 N·m (272 lb ft)
7/8	462 N·m (341 lb ft)	617 N·m (455 lb ft)	653 N·m (482 lb ft)	871 N·m (642 lb ft)	421 N·m (311 lb ft)	594 N·m (438 lb ft)
1	693 N·m (512 lb ft)	925 N·m (682 lb ft)	979 N·m (722 lb ft)	1305 N·m (963 lb ft)	631 N·m (465 lb ft)	890 N·m (656 lb ft)

IDENTIFICATION

Inch Bolts and free-spinning nuts

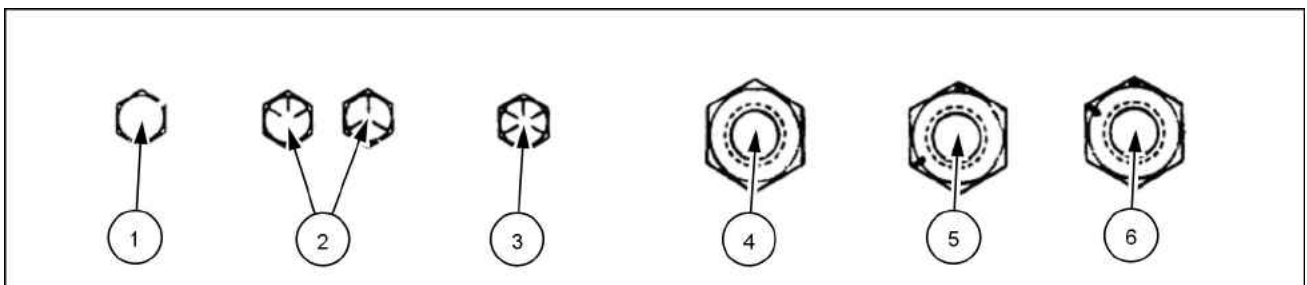

20083682 3

Grade Marking Examples

SAE Grade Identification			
1	Grade 2 - No Marks	4	Grade 2 Nut - No Marks
2	Grade 5 - Three Marks	5	Grade 5 Nut - Marks 120 ° Apart
3	Grade 8 - Five Marks	6	Grade 8 Nut - Marks 60 ° Apart

Inch Lock Nuts, All Metal (Three optional methods)

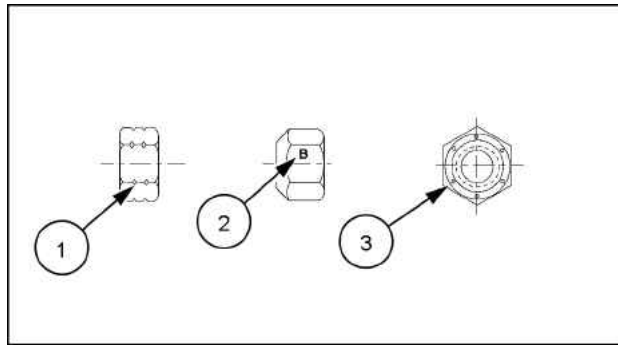

20090268 4

Grade Identification

Grade	Corner Marking Method (1)	Flats Marking Method (2)	Clock Marking Method (3)
Grade A	No Notches	No Mark	No Marks
Grade B	One Circumferential Notch	Letter B	Three Marks
Grade C	Two Circumferential Notches	Letter C	Six Marks

Torque - Standard torque data for hydraulics

INSTALLATION OF ADJUSTABLE FITTINGS IN STRAIGHT THREAD O RING BOSSES

1. Lubricate the O-ring by coating it with a light oil or petroleum. Install the O-ring in the groove adjacent to the metal backup washer which is assembled at the extreme end of the groove (4).
2. Install the fitting into the SAE straight thread boss until the metal backup washer contacts the face of the boss (5).

NOTE: Do not over tighten and distort the metal backup washer.

3. Position the fitting by turning out (counterclockwise) up to a maximum of one turn. Holding the pad of the fitting with a wrench, tighten the locknut and washer against the face of the boss (6).

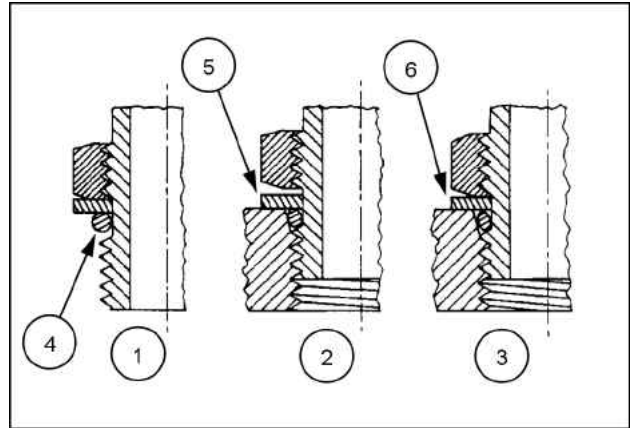

23085659 1

STANDARD TORQUE DATA FOR HYDRAULIC TUBES AND FITTINGS

TUBE NUTS FOR 37° FLARED FITTINGS				O-RING BOSS PLUGS ADJUSTABLE FITTING LOCKNUTS, SWIVEL JIC- 37° SEATS
SIZE	TUBING OD	THREAD SIZE	TORQUE	TORQUE
4	6.4 mm (1/4 in)	7/16-20	12 - 16 N·m (9 - 12 lb ft)	8 - 14 N·m (6 - 10 lb ft)
5	7.9 mm (5/16 in)	1/2-20	16 - 20 N·m (12 - 15 lb ft)	14 - 20 N·m (10 - 15 lb ft)
6	9.5 mm (3/8 in)	9/16-18	29 - 33 N·m (21 - 24 lb ft)	20 - 27 N·m (15 - 20 lb ft)
8	12.7 mm (1/2 in)	3/4-16	47 - 54 N·m (35 - 40 lb ft)	34 - 41 N·m (25 - 30 lb ft)
10	15.9 mm (5/8 in)	7/8-14	72 - 79 N·m (53 - 58 lb ft)	47 - 54 N·m (35 - 40 lb ft)
12	19.1 mm (3/4 in)	1-1/16-12	104 - 111 N·m (77 - 82 lb ft)	81 - 95 N·m (60 - 70 lb ft)
14	22.2 mm (7/8 in)	1-3/16-12	122 - 136 N·m (90 - 100 lb ft)	95 - 109 N·m (70 - 80 lb ft)
16	25.4 mm (1 in)	1-5/16-12	149 - 163 N·m (110 - 120 lb ft)	108 - 122 N·m (80 - 90 lb ft)
20	31.8 mm (1-1/4 in)	1-5/8-12	190 - 204 N·m (140 - 150 lb ft)	129 - 158 N·m (95 - 115 lb ft)
24	38.1 mm (1-1/2 in)	1-7/8-12	217 - 237 N·m (160 - 175 lb ft)	163 - 190 N·m (120 - 140 lb ft)
32	50.8 mm (2 in)	2-1/2-12	305 - 325 N·m (225 - 240 lb ft)	339 - 407 N·m (250 - 300 lb ft)

These torques are not recommended for tubes of 12.7 mm (1/2 in) OD and larger with wall thickness of 0.889 mm (0.035 in) or less. The torque is specified for 0.889 mm (0.035 in) wall tubes on each application individually.

Before installing and torquing 37 ° flared fittings, clean the face of the flare and threads with a clean solvent or Loctite cleaner and apply hydraulic sealant **LOCTITE® 569** to the 37 ° flare and the threads.

Install fitting and torque to specified torque, loosen fitting and retorquing to specifications.

PIPE THREAD FITTING TORQUE

Before installing and tightening pipe fittings, clean the threads with a clean solvent or Loctite cleaner and apply sealant **LOCTITE® 567 PST PIPE SEALANT** for all fittings including stainless steel or **LOCTITE® 565 PST** for most metal fittings. For high filtration/zero contamination systems use **LOCTITE® 545**.

PIPE THREAD FITTING	
Thread Size	Torque (Maximum)
1/8-27	13 N·m (10 lb ft)
1/4-18	16 N·m (12 lb ft)
3/8-18	22 N·m (16 lb ft)
1/2-14	41 N·m (30 lb ft)
3/4-14	54 N·m (40 lb ft)

INSTALLATION OF ORFS (O-RING FLAT FACED) FITTINGS

When installing ORFS fittings thoroughly clean both flat surfaces of the fittings **(1)** and lubricate the O-ring **(2)** with light oil. Make sure both surfaces are aligned properly. Torque the fitting to specified torque listed throughout the repair manual.

NOTICE: If the fitting surfaces are not properly cleaned, the O-ring will not seal properly. If the fitting surfaces are not properly aligned, the fittings may be damaged and will not seal properly.

NOTICE: Always use genuine factory replacement oils and filters to ensure proper lubrication and filtration of engine and hydraulic system oils.

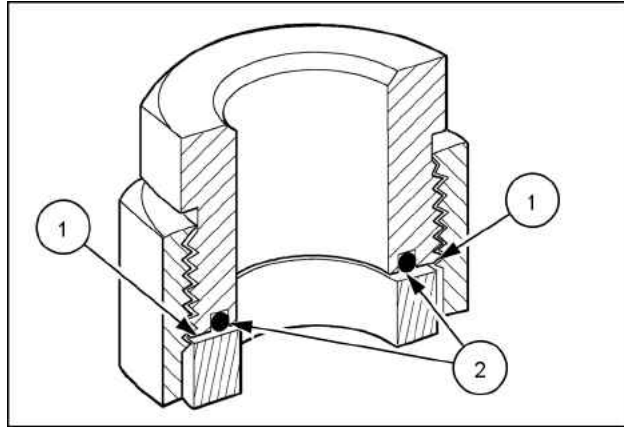

50011183 2

The use of proper oils, grease, and keeping the hydraulic system clean will extend machine and component life.

Hydraulic contamination

Contamination in the hydraulic system is a major cause of the malfunction of hydraulic components. Contamination is any foreign material in the hydraulic oil.

Contamination can enter the hydraulic system in several ways:

- When you drain the oil or disconnect any line
- When you disassemble a component
- From normal wear of the hydraulic components
- From damaged seals or worn seals
- From a damaged component in the hydraulic system

All hydraulic systems operate with some contamination. The design of the components in this hydraulic system permits efficient operation with a small amount of contamination. An increase in this amount of contamination can cause problems in the hydraulic system.

The following list includes some of these problems:

- Cylinder rod seals that leak
- Control valve spools that do not return to neutral
- Movement of control valve spools is difficult
- Hydraulic oil that becomes too hot
- Pump gears, housing, and other parts that wear rapidly
- Relief valves or check valves held open by dirt
- Quick failure of components that have been repaired
- Slow cycle times are slow. The machine does not have enough power.

If your machine has any of these problems, check the hydraulic oil for contamination.

There are two types of contamination: microscopic and visible.

Microscopic contamination occurs when very fine particles of foreign material are suspended in the hydraulic oil. These particles are too small to see or feel. Microscopic contamination can be found by identification of the following problems or by testing in a laboratory.

Examples of problems caused by microscopic contamination:

- Cylinder rod seals that leak
- Control valve spools that do not return to neutral
- The hydraulic system has a high operating temperature

Visible contamination is foreign material that can be found by sight, touch, or odor. Visible contamination can cause a sudden failure of components.

Examples of problems caused by visible contamination:

- Particles of metal or dirt in the oil
- Air in the oil
- Dark or thick oil
- Oil with an odor of burned oil
- Water in the oil

If you find contamination, use a portable filter to clean the hydraulic system.

Capacities

T7.230, T7.245, T7.260

Main fuel tank	312.0 L (82.4 US gal)
Auxiliary fuel tank	88.0 L (23.2 US gal)
DEF/ AdBlue®	56.0 L (14.8 US gal)

Cooling system	22.5 l (5.9 US gal)
----------------	----------------------------

Engine (including filter)	15 l (3.96 US gal)
---------------------------	---------------------------

Transmission/rear axle/hydraulics Power Command	82 l (21.7 US gal)
--	---------------------------

4WD front axle — differential	11 l (11.6 US qt)
-------------------------------	--------------------------

4WD front hubs (Class 4 axle — less brakes)	2.3 l (2.4 US qt)
--	--------------------------

4WD front hubs (Class 4 axle — with brakes)	3.8 l (4.0 US qt)
--	--------------------------

Front PTO	3.05 l (3.2 US qt)
-----------	---------------------------

T7.230 AC, T7.245 AC, T7.260 AC, T7.270 AC

Main fuel tank	312.0 L (82.4 US gal)
Auxiliary fuel tank	88.0 L (23.2 US gal)
DEF/ AdBlue®	56.0 L (14.8 US gal)

Cooling system	22.5 l (5.9 US gal)
----------------	----------------------------

Engine (including filter)	15 l (3.96 US gal)
---------------------------	---------------------------

Transmission/rear axle/hydraulics CVT Transmission	84 l (22.2 US gal)
---	---------------------------

4WD front axle — differential	11 l (11.6 US qt)
-------------------------------	--------------------------

4WD front hubs (Class 4 axle — less brakes)	2.3 l (2.4 US qt)
--	--------------------------

4WD front hubs (Class 4 axle — with brakes)	3.8 l (4.0 US qt)
--	--------------------------

Front PTO	3.05 l (3.2 US qt)
-----------	---------------------------

Consumables

Lubrications

The correct engine oil viscosity grade is dependent upon ambient temperature. Refer to the chart when selecting oil for your tractor engine.

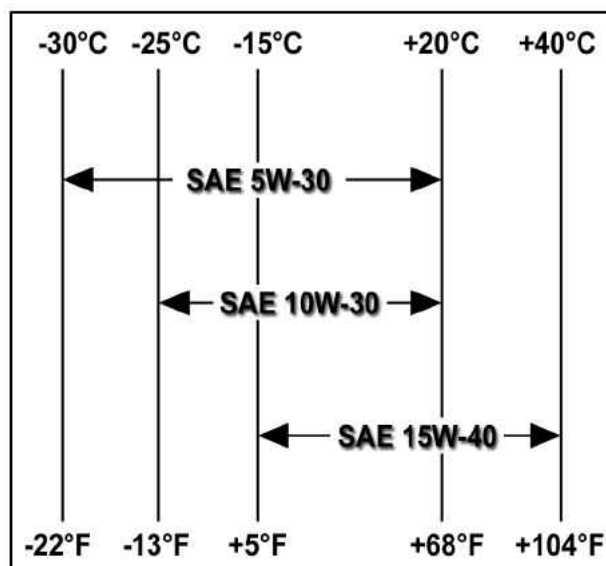

SS09J076 1

NOTE: In areas where prolonged periods of extreme temperatures are encountered, local lubricant practices are acceptable; such as the use of **SAE 5W30** in extreme low temperatures or **SAE 50** in extreme high temperatures.

Biodegradable transmission and hydraulic oil

⚠ WARNING

Burn hazard!

Be very careful to avoid contact with hot fluids. If fluid is extremely hot, allow it to cool to a moderately warm temperature before proceeding.

Failure to comply could result in death or serious injury.

W0362A

A biodegradable oil has been approved for use in the transmission, 4WD front axle and hubs, and the hydraulic system of your tractor. Although the oil is **90 %** biodegradable, it is important to follow safe handling and disposal practices.

The **NEW HOLLAND AMBRA MULTI BIO** oil is available from your authorized dealer.

Biodegradable oil should not be used in conjunction with other oils. Use the following procedure to replace standard oil with biodegradable lubricant.

1. Operate the tractor until the oil that is being changed reaches a temperature greater than **60 °C (140 °F)**.
2. Stop the engine and immediately drain the oil.
3. Replace all transmission and hydraulic filters.
4. Add the biodegradable oil to the correct level and run the tractor to circulate the oil.
5. Check for oil leaks and recheck the oil level.

Sulphur in fuel

The engine oil and filter change period are shown in the Lubrication and Maintenance in the operators manual. However, locally available fuel may have a high sulphur content, in which case the engine oil and filter change period should be adjusted as follows:

Sulphur content	Oil change period
Below 5 mg/kg (5 ppm)	Normal
From 5 - 10 mg/kg (5-10 ppm)	Half the normal
Above 10 mg/kg (10 ppm)	One quarter normal

Coolants

WARNING

Hazardous chemicals!

Chemical agent may be harmful.

-Avoid contact with eyes, and prolonged/repeated skin contact.

-Wear protective goggles when handling.

-Eye contact: Flush with water for 15 minutes. Seek immediate medical assistance.

-Wash skin with soap and water after handling.

-Keep out of reach of children.

Failure to comply could result in death or serious injury.

W0370A

To reduce the amount of deposits and corrosion, the water used in the cooling system must comply with the following values.

Property	Maximum value
Total solids	340 mg/kg (340 ppm)
Total hardness	9.5°dH (170 ppm)
Chloride (cl)	40 mg/kg (40 ppm)
Sulfate (SO4)	100 mg/kg (100 ppm)
Acidity pH	5.5 to 9.0

Using plain water

If you reside in a country where antifreeze is not available, use clean water premixed with **5 %** chemical inhibitor. The inhibitor is available from your authorized dealer.

Lubrications and coolant specifications

Recommended fluids and applications	CNH specification	International specification
Recommended engine oil NEW HOLLAND AMBRA UNITEK 10W-40, NEW HOLLAND AMBRA UNITEK SSL 0W-40	MAT 3521	API CJ-4, ACEA E9
Alternative engine oil NEW HOLLAND AMBRA MASTERGOLD™ HSP ENGINE OIL SAE 15W-40, NEW HOLLAND AMBRA MASTERGOLD™ HSP ENGINE OIL SAE 10W-30	NH 330 H, NH 324 H	API CJ-4, ACEA E7
Recommended transmission, rear axle and hydraulic system oil, front axle (axle and hubs) and front PTO gearbox oil NEW HOLLAND AMBRA MASTERTRAN® ULTRACTION	MAT 3540	n/a
Alternative transmission, rear axle and hydraulic system oil, front axle (axle and hubs) and front PTO gearbox oil NEW HOLLAND AMBRA MULTI G™ HYDRAULIC TRANSMISSION OIL	MAT 3525	SAE 10W-30, API GL4, ISO VG32/46
Engine coolant fluid NEW HOLLAND AMBRA ACTIFULL™ OT EXTENDED LIFE COOLANT (If a premixed coolant is not available, mix the concentrate with 50 % of water)	MAT 3624	ASTM D 6210 Fully Organic Technology
Brake oil NEW HOLLAND AMBRA BRAKE LHM	NH 610 A	ISO 7308
Air conditioning compressor oil Low Viscosity Oil SP10	n/a	PAG-E13 ISO100 Viscosity
Grease fittings and bearings NEW HOLLAND AMBRA GR-9 MULTI-PURPOSE GREASE	251H EP	NLGI2, Li-Ca

Regarding filling quantity - see **Capacities ()** .

NOTE: It is possible to mix **NEW HOLLAND AMBRA MASTERTRAN® ULTRACTION** with the other **NEW HOLLAND AMBRA MULTI G™ HYDRAULIC TRANSMISSION OIL** products until their current supply is depleted and a total changeover to **NEW HOLLAND AMBRA MASTERTRAN® ULTRACTION** in the hydraulic system is possible.

NOTE: Wrong oil introduced in the drive line will reduce performance and durability.



SERVICE MANUAL

Engine

**T7.230 AutoCommand™, T7.230, T7.245 AutoCommand™, T7.245, T7.260
AutoCommand™, T7.260, T7.270 AutoCommand™**

Contents

Engine - 10

[10.001] Engine and crankcase	10.1
[10.216] Fuel tanks	10.2
[10.218] Fuel injection system.....	10.3
[10.254] Intake and exhaust manifolds and muffler	10.4
[10.500] Selective Catalytic Reduction (SCR) exhaust treatment.....	10.5
[10.400] Engine cooling system	10.6
[10.414] Fan and drive	10.7
[10.408] Oil cooler and lines.....	10.8
[10.101] Cylinder heads	10.9



Engine - 10

Engine and crankcase - 001

**T7.230 AutoCommand™, T7.230, T7.245 AutoCommand™, T7.245, T7.260
AutoCommand™, T7.260, T7.270 AutoCommand™**

Contents

Engine - 10

Engine and crankcase - 001

SERVICE

Engine

Remove	3
Disconnect	18
Install	35
Connect	49

Engine - Remove

Prior operation:

Separate the front axle and front frame from the engine, for further information refer to **Front frame - Remove (39.100)**

Prior operation:

Remove the left-hand fuel tank, for further information refer to **Fuel tank - Remove (10.216)**

Prior operation:

Remove the selective catalytic reduction (SRC) muffler, for further information refer to **Selective Catalytic Reduction (SCR) muffler and catalyst - Remove (10.500)**

Prior operation:

Remove the engine hood, for further information refer to **Hood - Remove (90.100)**

⚠ WARNING

Heavy objects!

Lift and handle all heavy components using lifting equipment with adequate capacity. Always support units or parts with suitable slings or hooks. Make sure the work area is clear of all bystanders.

Failure to comply could result in death or serious injury.

W0398A

⚠ WARNING

Avoid injury!

Handle all parts carefully. Do not place your hands or fingers between parts. Use Personal Protective Equipment (PPE) as indicated in this manual, including protective goggles, gloves, and safety footwear.

Failure to comply could result in death or serious injury.

W0208A

NOTICE: Avoid DEF/AdBLUE® contamination of the electrical connector by disconnecting the DEF/AdBLUE® connectors first.

1. Disconnect the radar electrical connector (if fitted).
2. Remove the radar (if fitted).

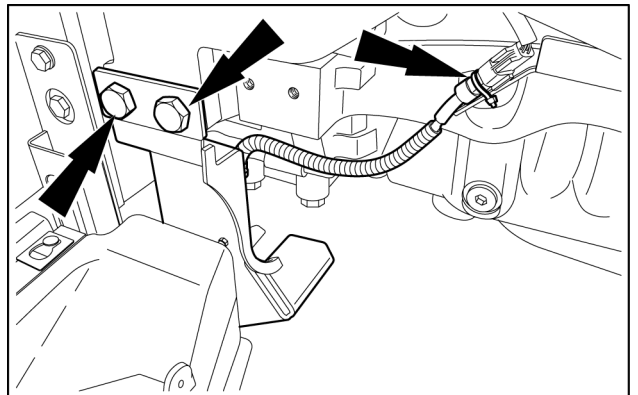

BAIL13TR01648AB 1

Vehicles with front hitch

2. Disconnect the mid-mount pipes from the mid-mount valve.

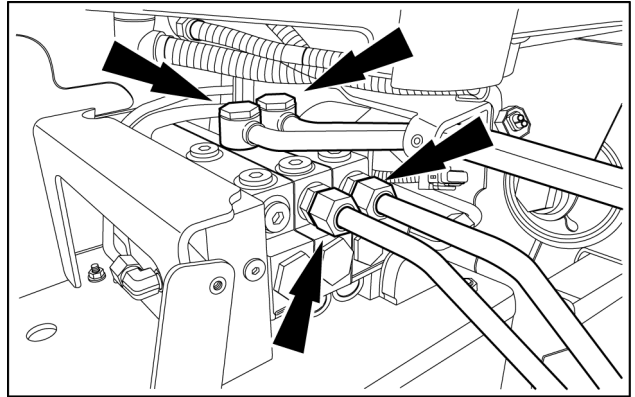

BAIL13TR01645AB 2

3. Remove the front hitch pipes.

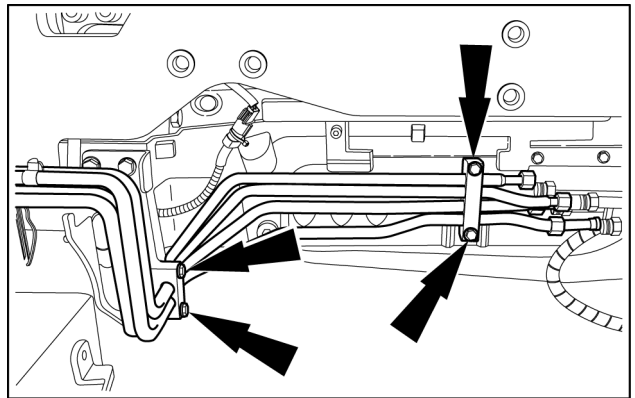

BAIL13TR01647AB 3

4. Remove the starter motor cover.

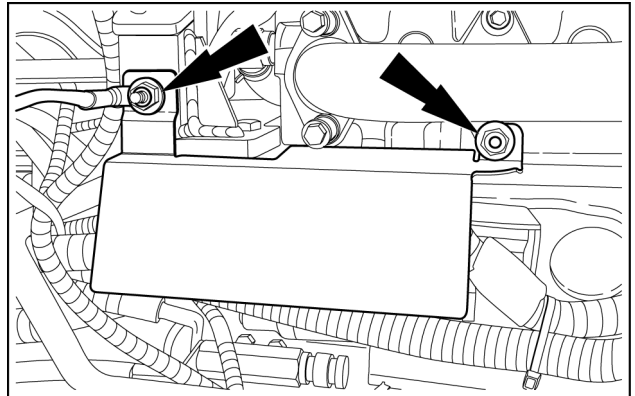

BAIL14TR00276AB 4

5. Remove the oil cooler pipe bracket.

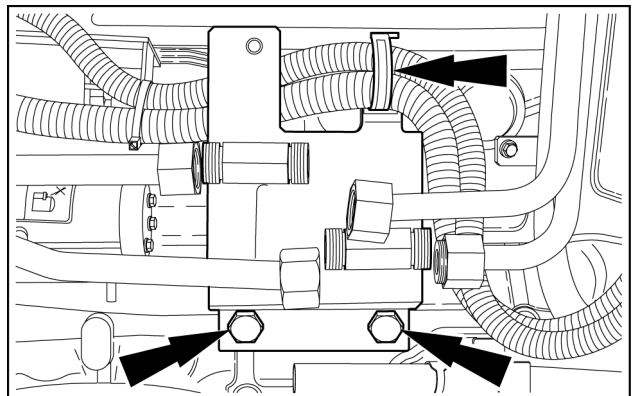

BAIL14TR00277AB 5

6. Detach the fuse box and position it to one side.

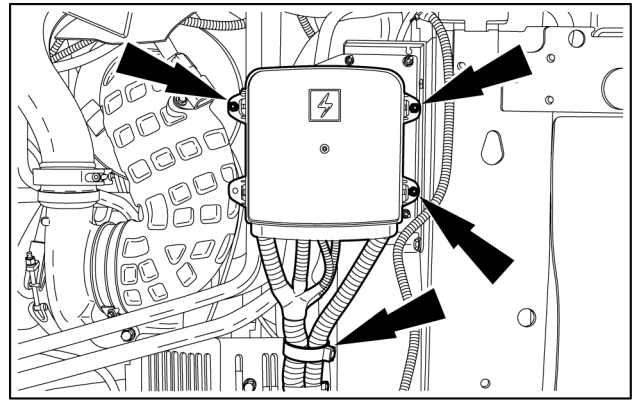

BAIL13TR01663AB 6

7. Disconnect the starter motor positive cables.

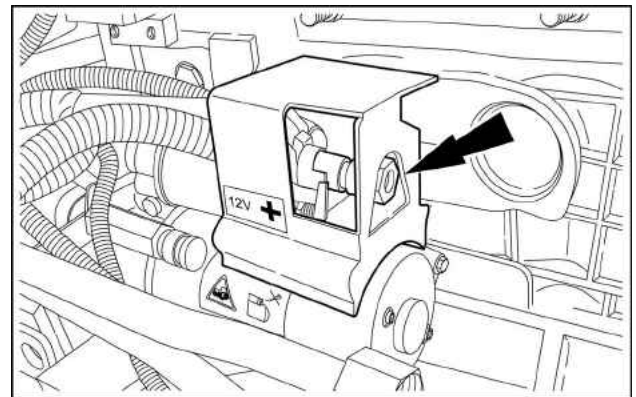

BAIL14TR00278AA 7

8. Disconnect the starter motor electrical connector.

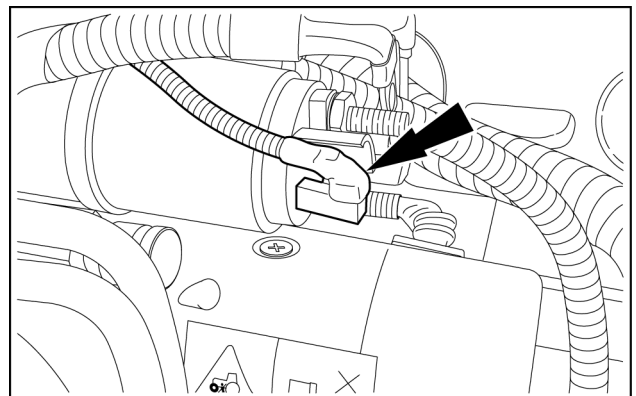

BAIL13TR01660AB 8

9. Disconnect the starter motor negative terminal.

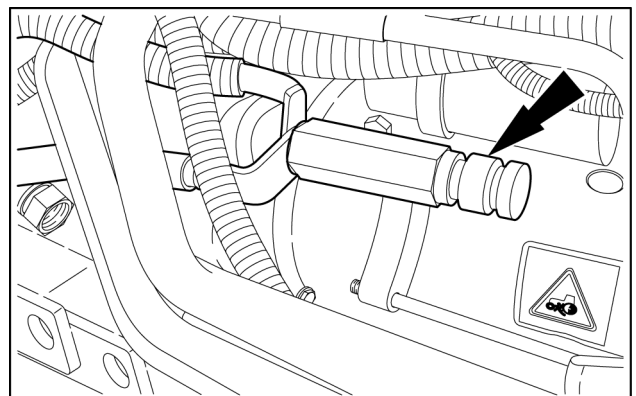

BAIL13TR01661AB 9

10. Disconnect the front axle electrical connectors.

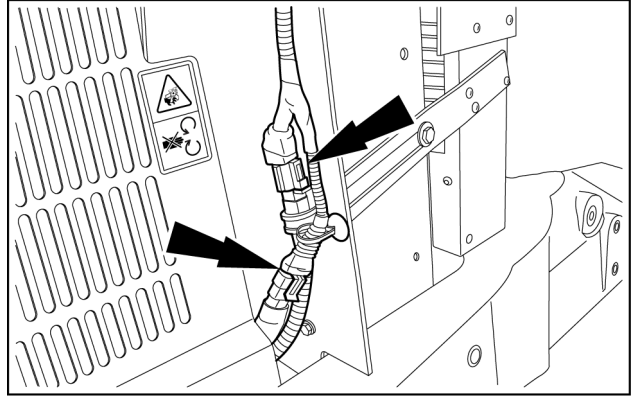

BAIL13TR01683AB 10

11. Disconnect the brake master cylinder oil supply pipes.

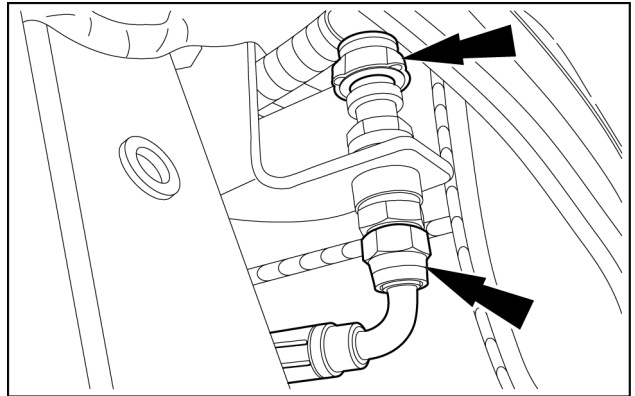

BAIL14TR00279AB 11

12. Disconnect the cab hand rail light electrical connectors (on both sides).

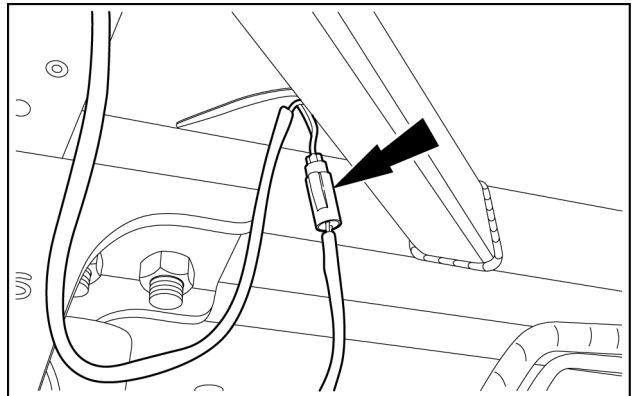

BAIL14TR00280AB 12

13. 1. Disconnect the steering pipes.
2. Disconnect the brake pipe.

NOTE: Mark the hoses to aid installation.

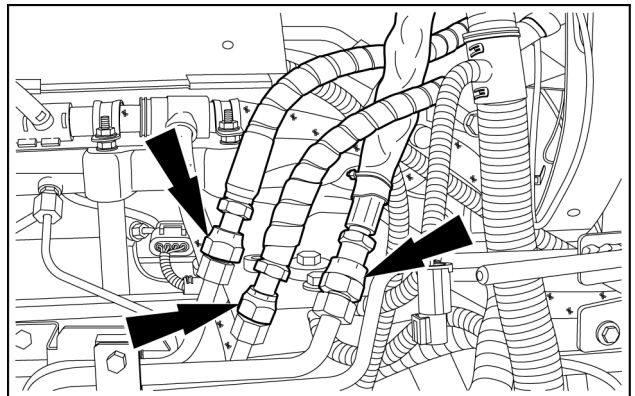

BAIL14TR00281AB 13

14. Disconnect the ground cables.

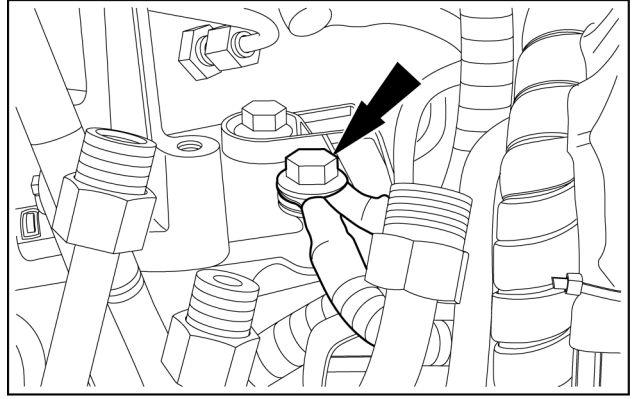

BAIL14TR00282AB 14

15. Disconnect the generator electrical connectors.

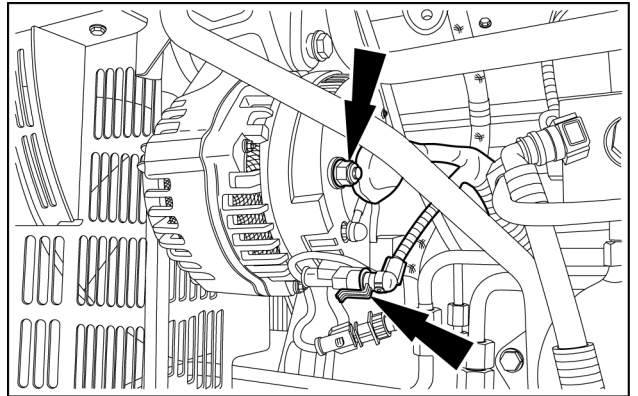

BAIL14TR00283AB 15

16. 1. Disconnect the brake accumulator electrical connector.
2. Disconnect the water-in-fuel sensor electrical connector.

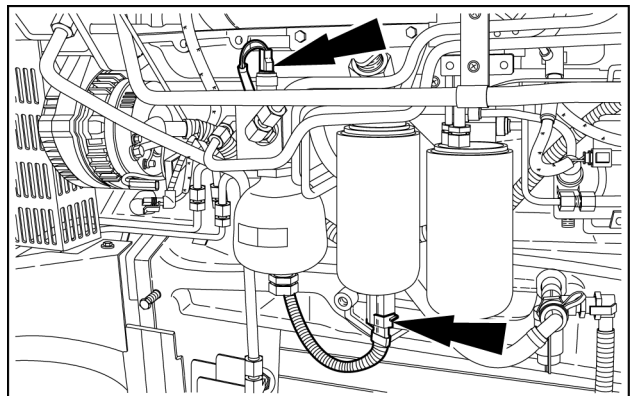

BAIL14TR00284AB 16

17. 1. Disconnect the flywheel speed sensor electrical connector.
2. Disconnect the engine wiring harness.

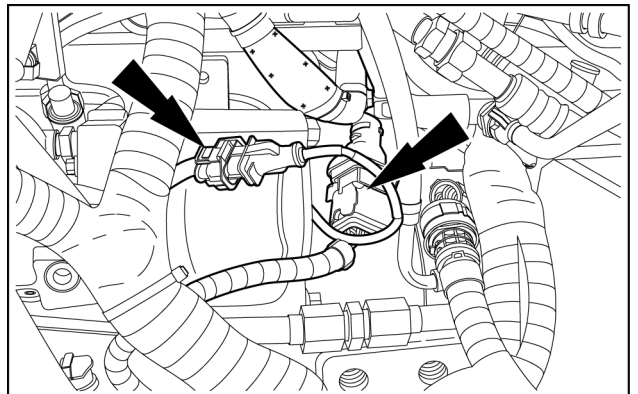

BAIL14TR00285AB 17

18. Disconnect the air conditioning (A/C) pipes.

NOTE: Make sure that all openings are sealed. Use new blanking caps.

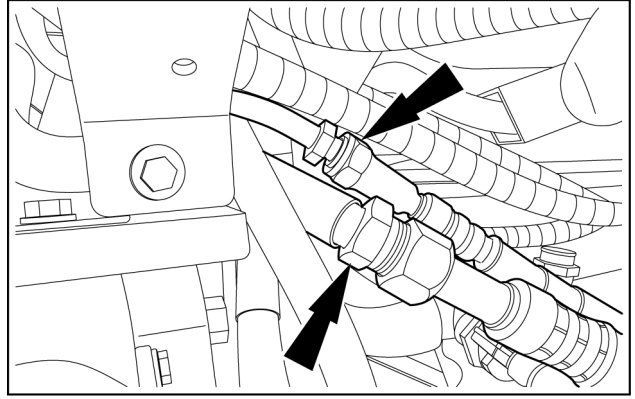

BAIL14TR00286AB 18

19. 1. Disconnect the coolant hose.
2. Disconnect the brake pipe.

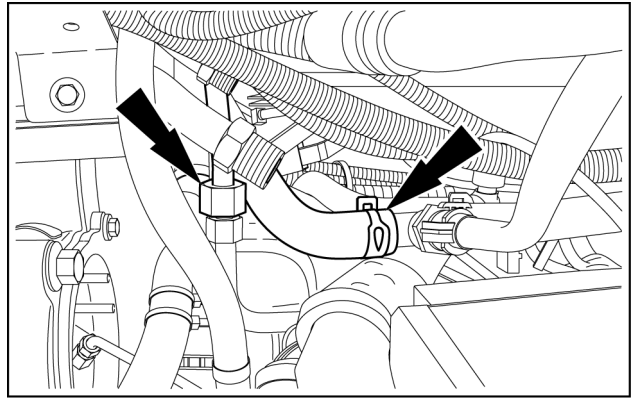

BAIL14TR00287AB 19

20. Cut the cable ties.

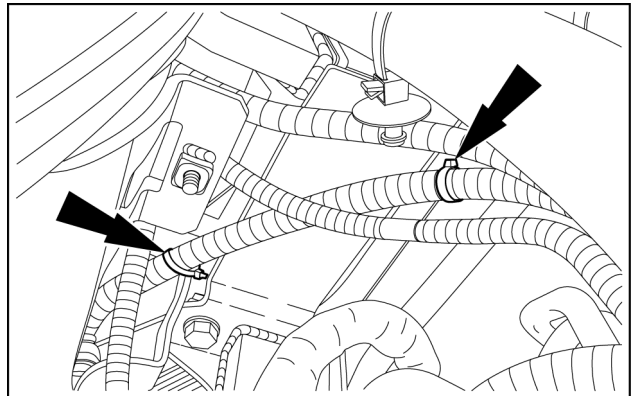

BAIL14TR00288AB 20

21. 1. Disconnect the Diesel Oxidation Catalyst (DOC) electrical connector.
2. Disconnect the hood wiring harness electrical connector.

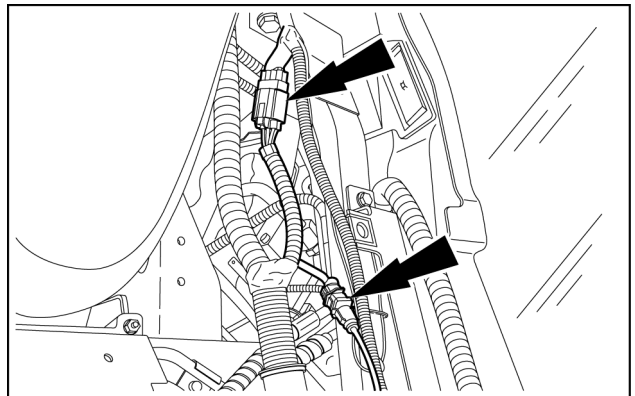

BAIL14TR00289AB 21

22. Cut the cable ties.

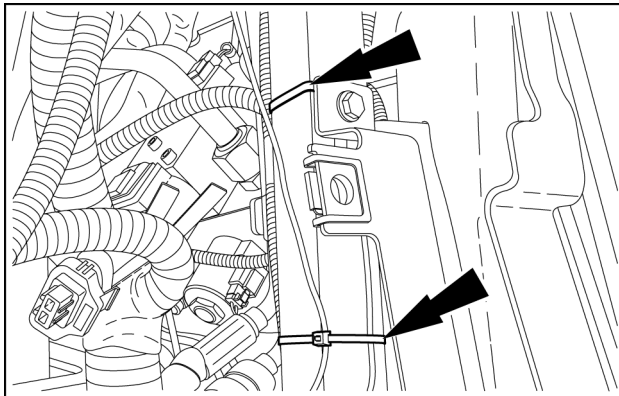

BAIL14TR00290AB 22

23. 1. Detach the DOC wiring harness and the **DEF/AdBLUE®** lines.
2. Detach the wiring harness.

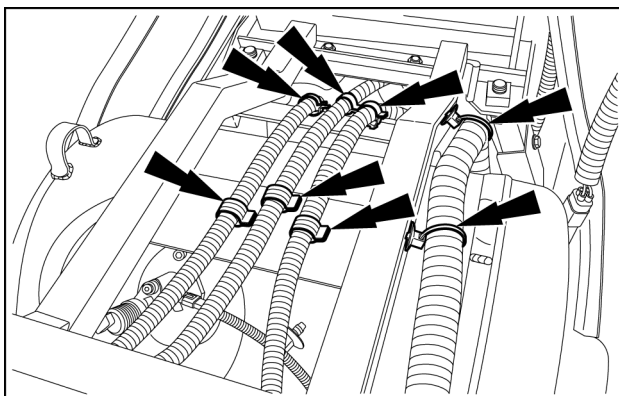

BAIL14TR00291AB 23

24. Disconnect the dosing module.
1. Disconnect the **DEF/AdBLUE®** lines.
2. Disconnect the dosing module electrical connector.

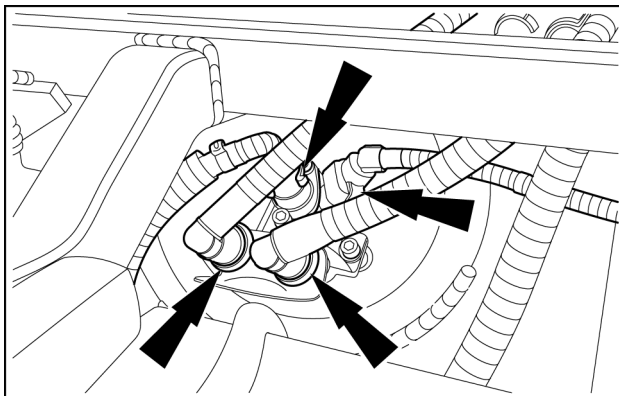

BAIL14TR00292AB 24

25. 1. Detach the wiring harness.
2. Cut the cable ties.

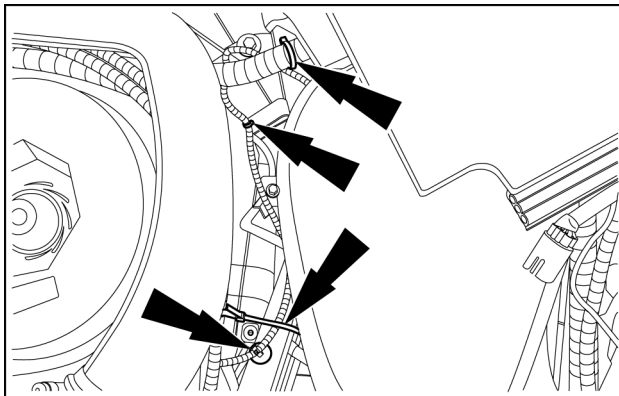

BAIL14TR00293AB 25

26. Cut the cable ties.

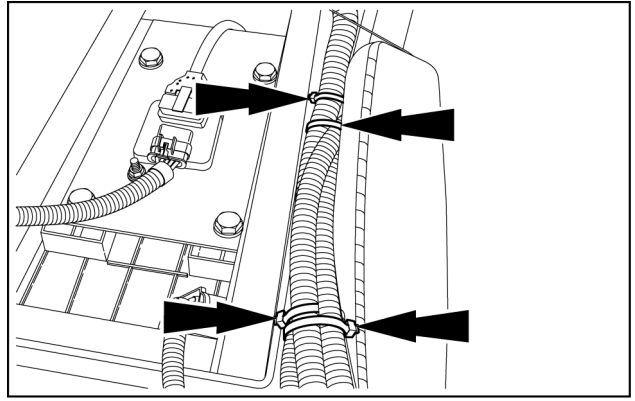

BAIL14TR00294AB 26

27. 1. Disconnect the fan electrical connector.
2. Disconnect front hitch electrical connector.

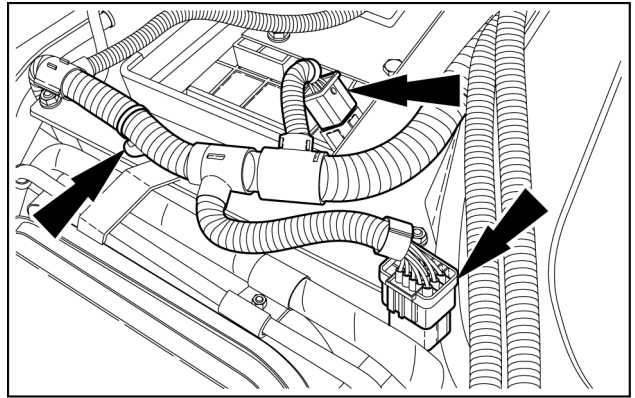

BAIL14TR00295AB 27

28. 1. Disconnect the NOx amplifier electrical connector.
2. Disconnect the coolant level sensor electrical connector.

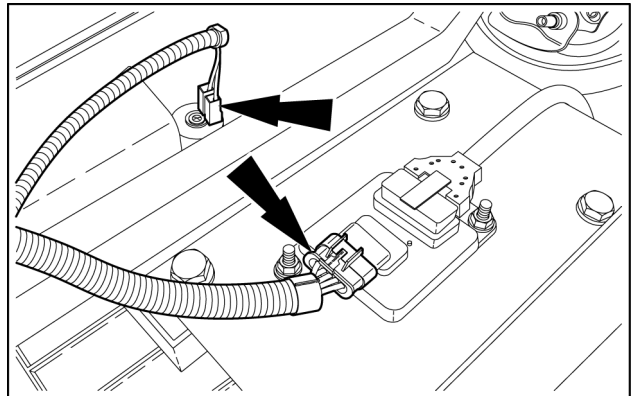

BAIL14TR00296AB 28

29. 1. Disconnect the AC pressure switch electrical connector.
2. Cut the cable tie.

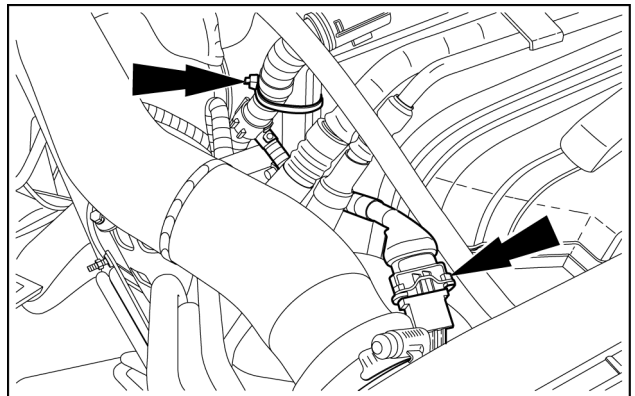

BAIL14TR00297AB 29

30. 1. Disconnect the air intake sensor electrical connector.
2. Disconnect the A/C compressor electrical connector.

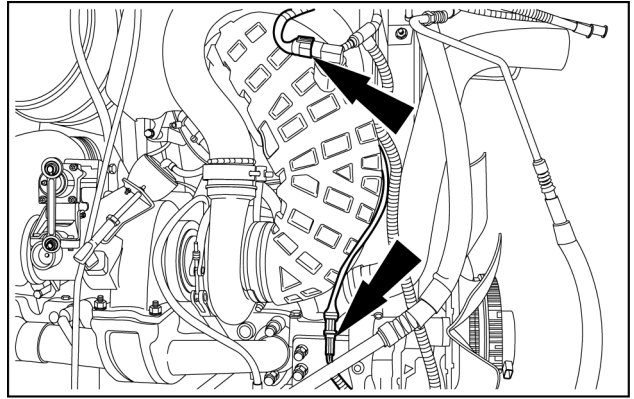

BAIL14TR00316AB 30

31. Remove the right-hand air intake pipe.

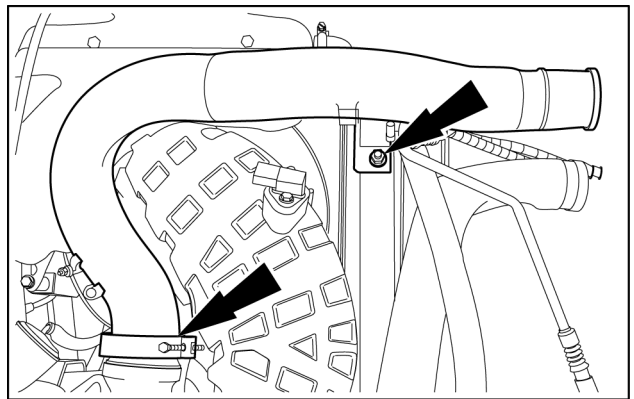

BAIL14TR00317AB 31

32. Remove the left-hand air intake pipe.

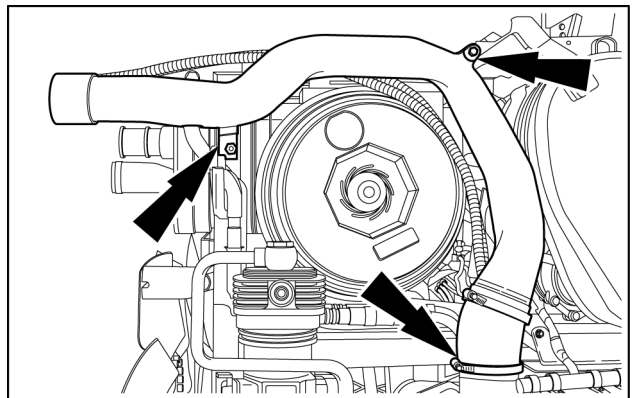

BAIL14TR00318AB 32

33. 1. Disconnect the air compressor supply pipe.
2. Disconnect the valve cover breather pipe.

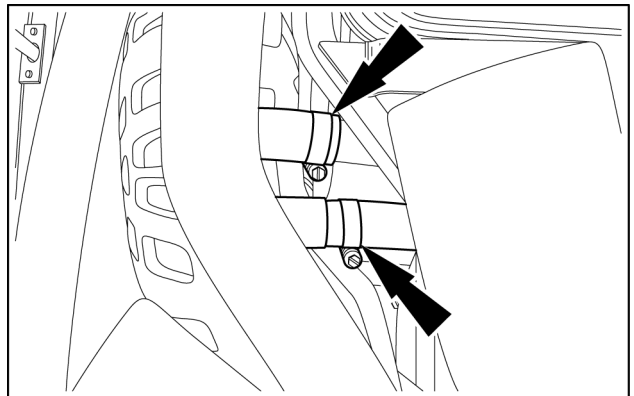

BAIL14TR00319AB 33

34. Remove the air cleaner outlet pipe.

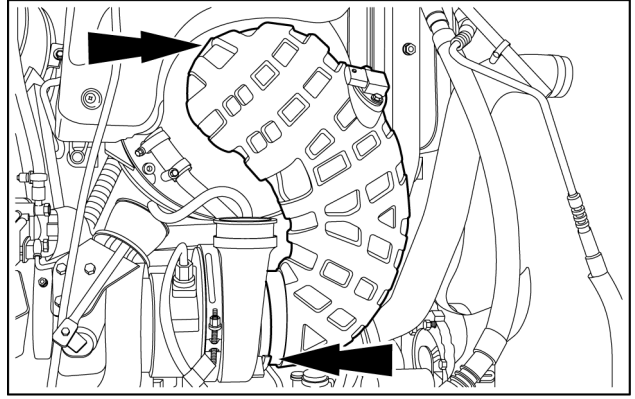

BAIL14TR00320AB 34

35. 1. Disconnect the coolant hose from the exhaust flap.
2. Disconnect the coolant expansion tank hose.
3. Remove the up-stream Nox sensor.

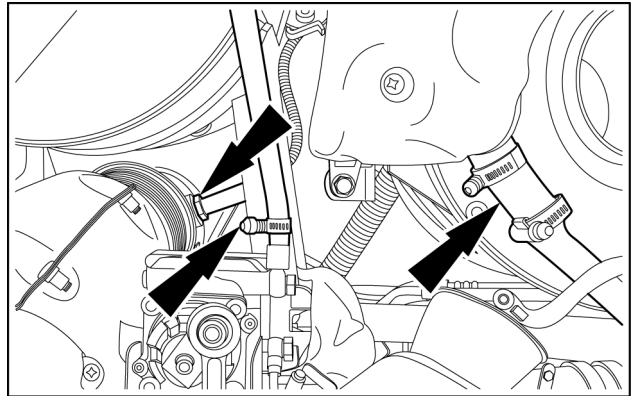

BAIL14TR00321AB 35

36. Disconnect the engine frame upper retaining bolts.

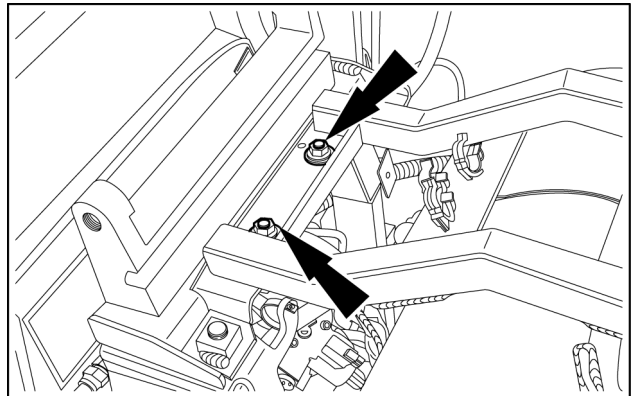

BAIL14TR00323AB 36

37. 1. Remove the engine frame front retaining nuts.
2. Remove the upper part of the engine frame.

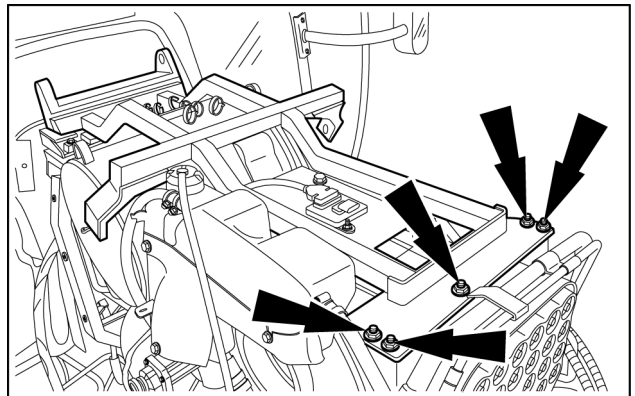

BAIL14TR00324AB 37

38. 1. Disconnect the coolant lines from the exhaust flap.
2. Disconnect the exhaust flap electrical connector.

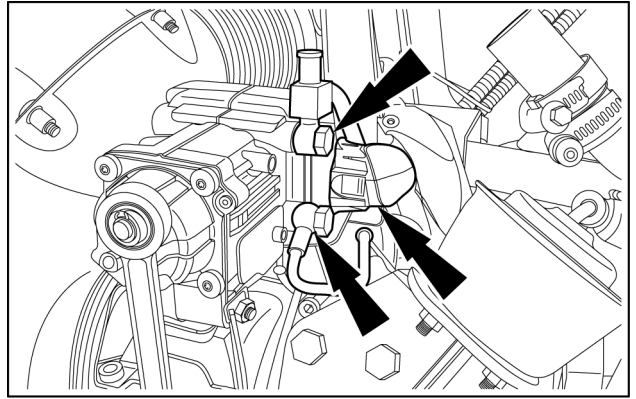

BAIL14TR00325AB 38

39. Remove the DOC frame rear retaining bolts.

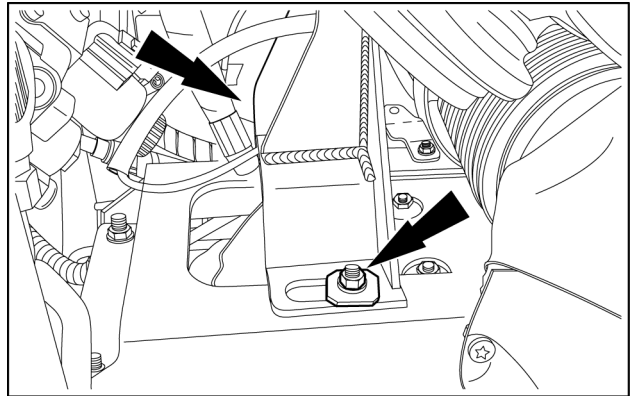

BAIL14TR00326AB 39

40. Remove the exhaust flap and exhaust front pipe.

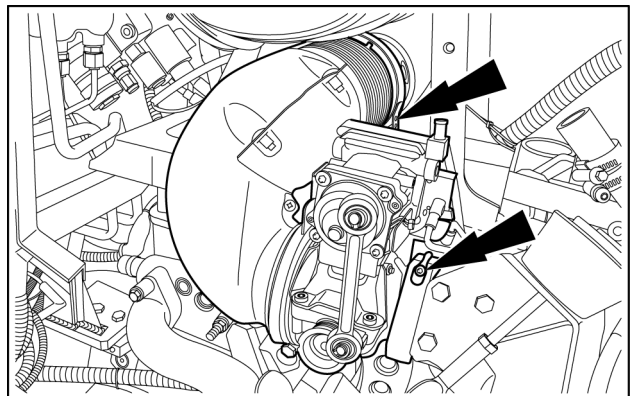

BAIL14TR00327AB 40

41. Remove the DOC and frame.

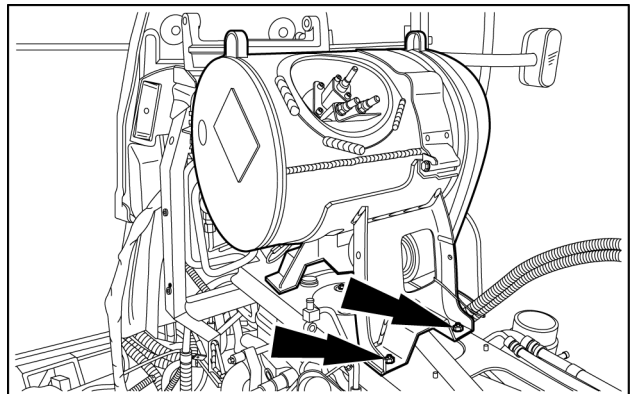

BAIL14TR00328AB 41

42. Remove the lower part of the engine frame.

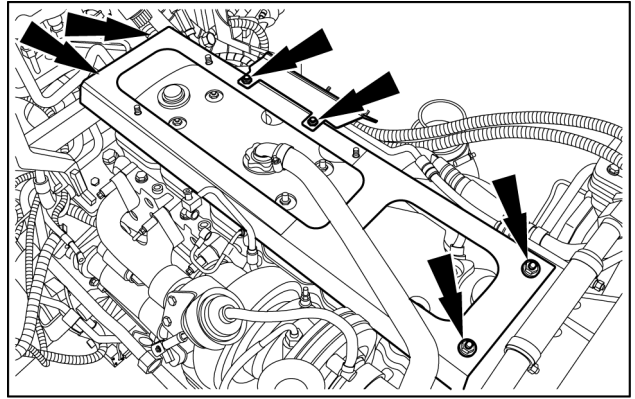

BAIL14TR00329AB 42

43. Remove the engine side cover bracket.

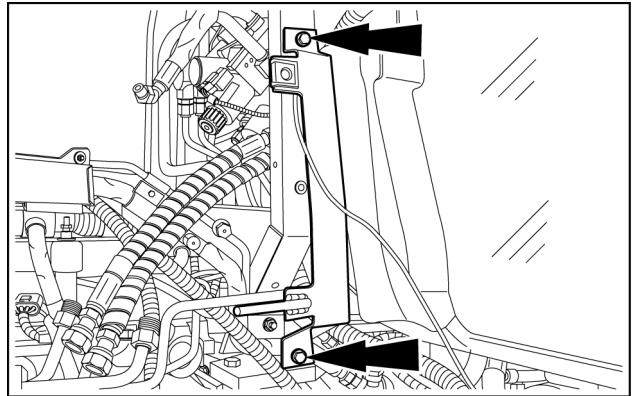

BAIL14TR00330AB 43

44. Remove the rear part of the engine frame.

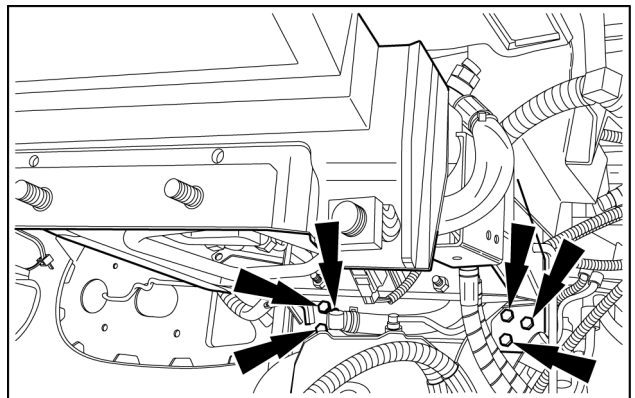

BAIL14TR00331AB 44

45. Remove the A/C pipes.

NOTE: Install blanking plugs.

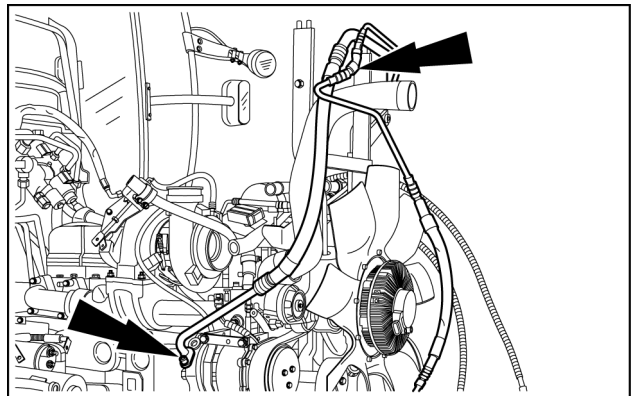

BAIL14TR00332AB 45

46. Remove the air compressor intake pipe.

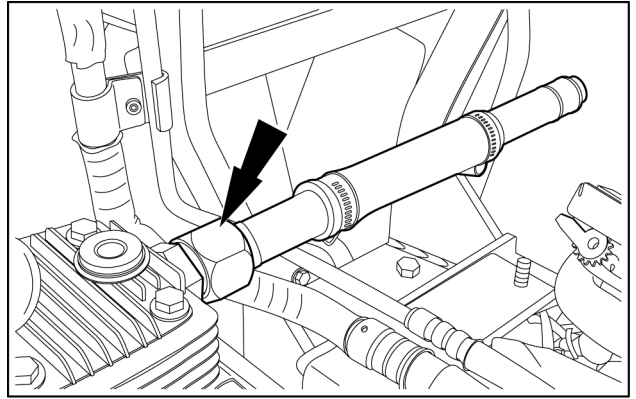

BAIL14TR00333AB 46

47. Remove the engine frame front retaining bolts.

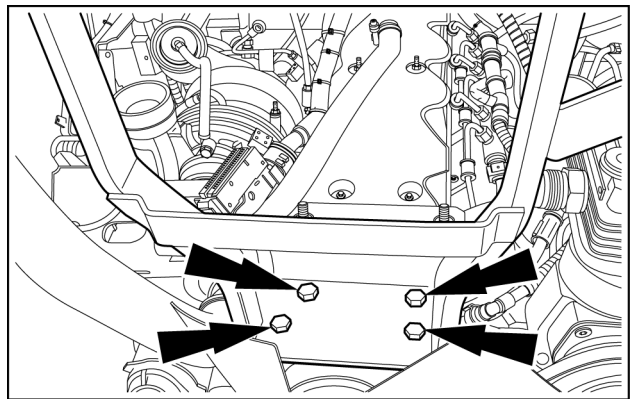

BAIL14TR00334AB 47

48. Position the static part of the tractor splitting stand **380003352** under the transmission and secure to the transmission.

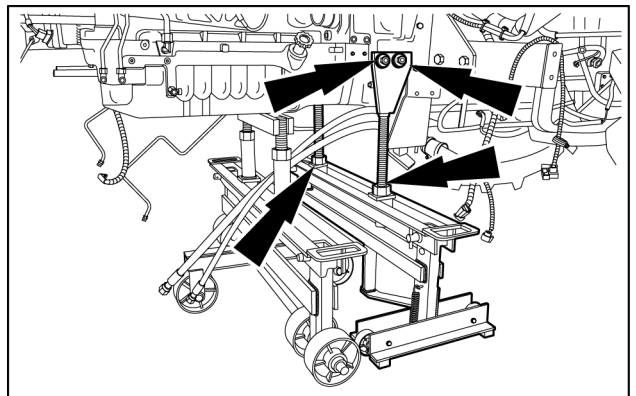

BAIL13TR01728AB 48

49. Install three engine lifting eyes **380200013**.

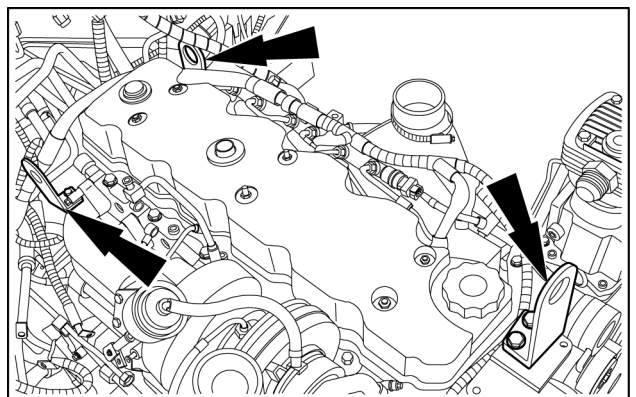

BAIL14TR00335AB 49

50. Using suitable lighting equipment, support the engine.

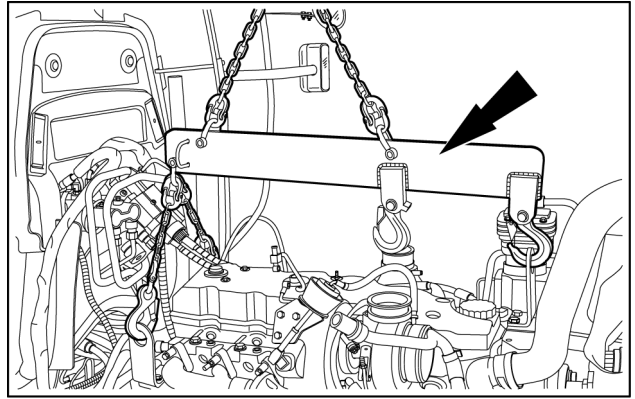

BAIL14TR00336AB 50

51. Remove the engine to transmission lower retaining bolts.

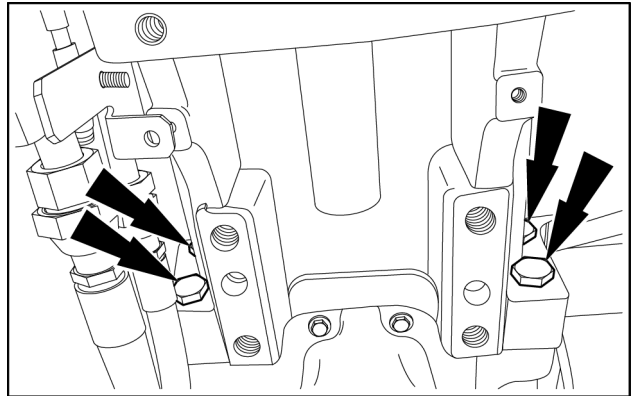

BAIL13TR01727AB 51

52. Remove the engine to transmission upper retaining bolts.

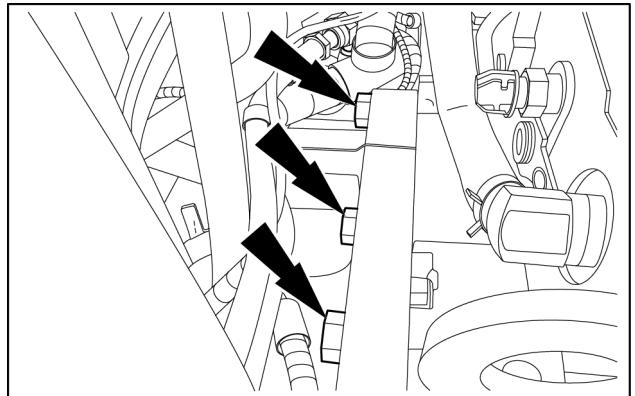

BAIL13TR01757AB 52

53. Remove the engine to transmission left-hand side retaining bolts.

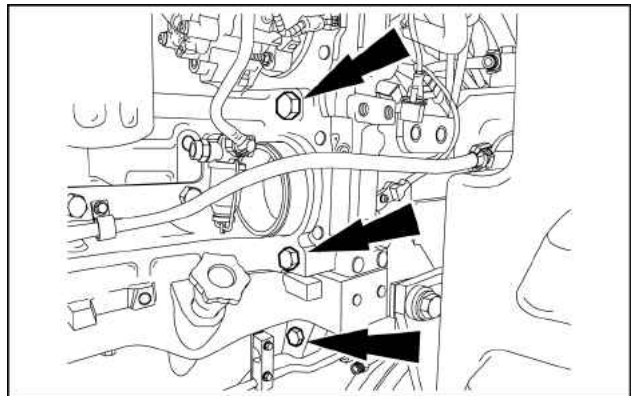

BAIL13TR00796AB 53

54. Remove the engine to transmission right-hand side retaining bolts.

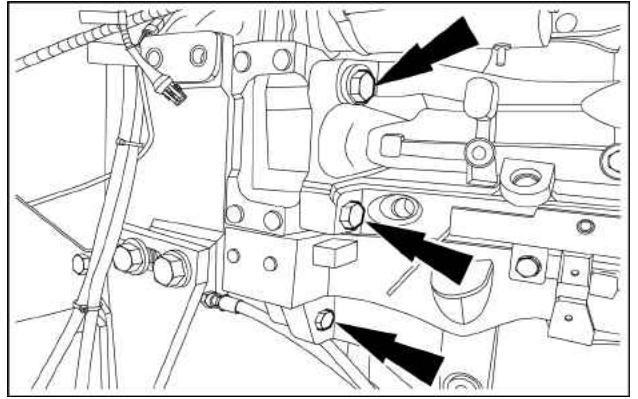

BAIL13TR00797AC 54

55. Using suitable lighting equipment, remove the engine.

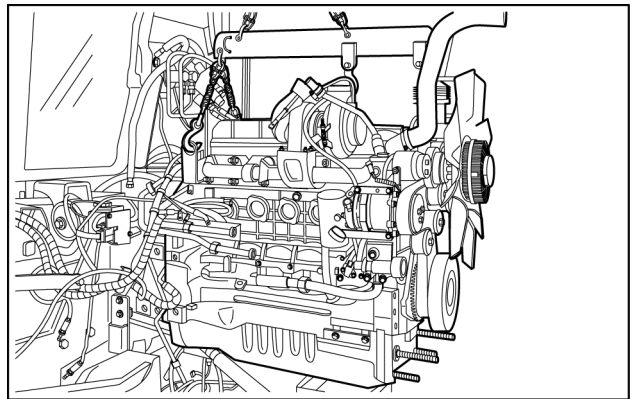

BAIL14TR00337AA 55

Engine - Disconnect

Prior operation:

Discharge the Air conditioning system, for further information refer to **Air conditioning - Discharging (50.200)**

Prior operation:

Drain the engine cooling system, for further information refer to **Engine cooling system - Drain fluid (10.400)**

Prior operation:

Disconnect the battery ground cable, for further information refer to **Battery - Disconnect (55.302)**

Prior operation:

Remove the Selective Catalytic Reduction (SCR) muffler, for further information refer to **Selective Catalytic Reduction (SCR) muffler and catalyst - Remove (10.500)**

Prior operation:

Remove the left-hand fuel tank, for further information refer to **Fuel tank - Remove (10.216)**

⚠ WARNING

Heavy objects!

Lift and handle all heavy components using lifting equipment with adequate capacity. Always support units or parts with suitable slings or hooks. Make sure the work area is clear of all bystanders.

Failure to comply could result in death or serious injury.

W0398A

⚠ WARNING

Avoid injury!

Handle all parts carefully. Do not place your hands or fingers between parts. Use Personal Protective Equipment (PPE) as indicated in this manual, including protective goggles, gloves, and safety footwear.

Failure to comply could result in death or serious injury.

W0208A

NOTICE: Avoid DEF/AdBLUE® contamination of the electrical connector by connecting the DEF/AdBLUE® connectors last.

1. ⚠ WARNING

Crushing hazard!

The wheels on this vehicle are very heavy. Always use a wheel remover or chain hoists to remove and install the wheels. Use an assistant as required.

Failure to comply could result in death or serious injury.

W0149A

Install the left-hand rear wheel.

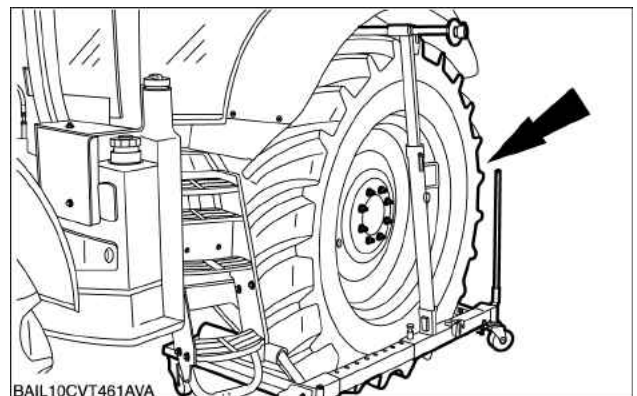

BAIL10CVT461AVA 1

2. A. Remove the transmission housing drain plug and drain the transmission oil into a suitable container.
- B. Install the drain plug and torque to **68 - 82 N·m (50 - 60 lb ft)**

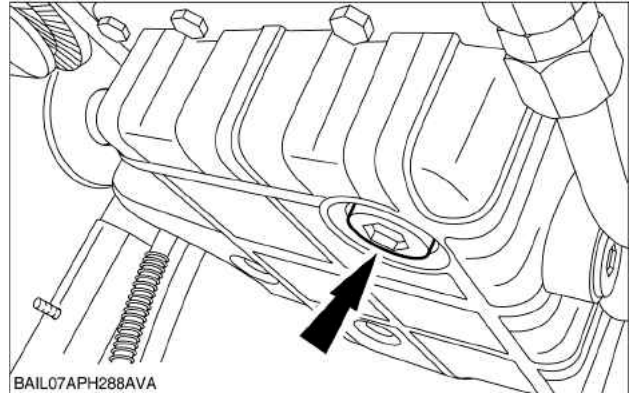

BAIL07APH288AVA 2

3. 1. Disconnect the radar electrical connector and remove radar (if fitted).
2. Remove the radar (if fitted).

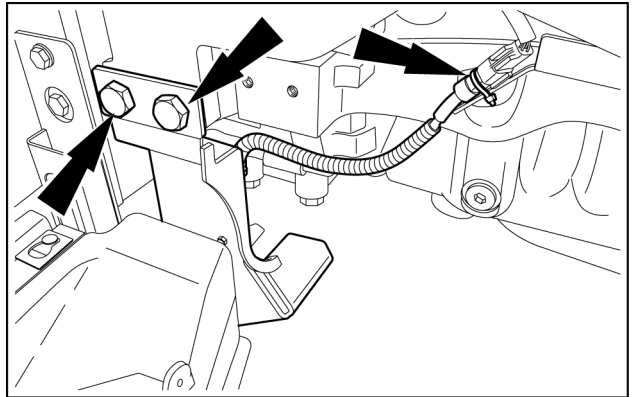

BAIL13TR01648AB 3

Vehicles with front hitch

4. **⚠ WARNING**

Heavy object!
ALWAYS use a hoist or get assistance to lift the component.
Failure to comply could result in death or serious injury.

W0086A

Remove the right-hand side rail.

NOTE: Repeat this step for the left-hand side.

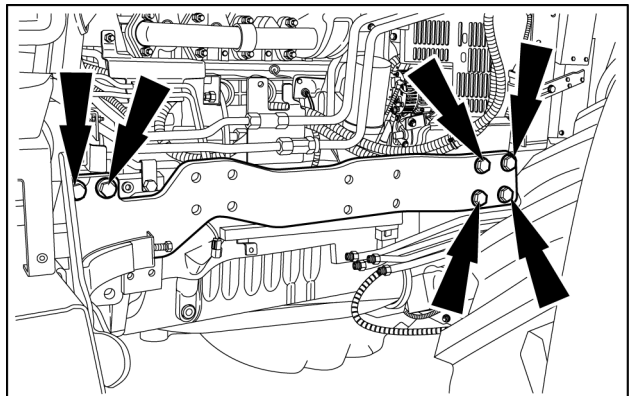

BAIL13TR01649AB 4

5. Disconnect the oil cooler supply and return pipes.

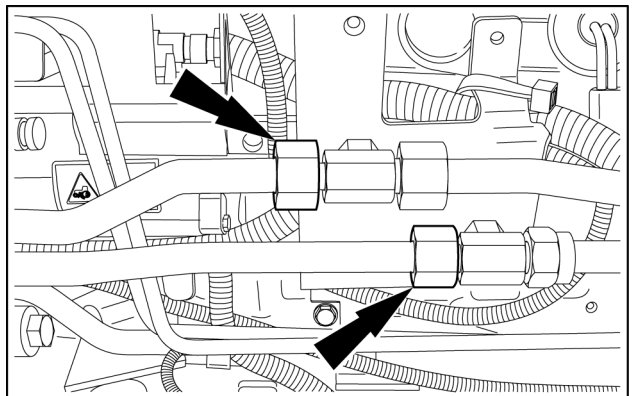

BAIL13TR01656AB 5

6. Detach the cab heater supply pipe.

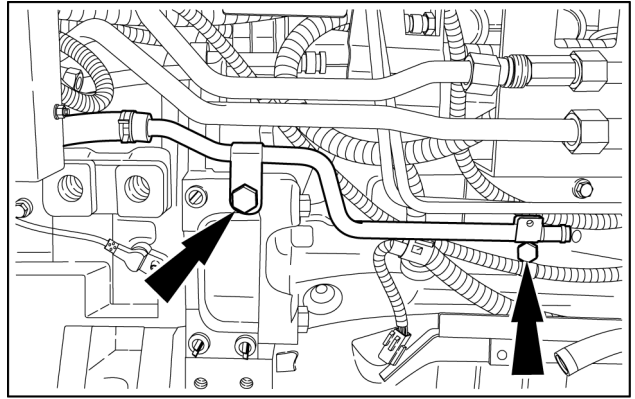

BAIL13TR01657AB 6

7. Remove the starter motor cover.

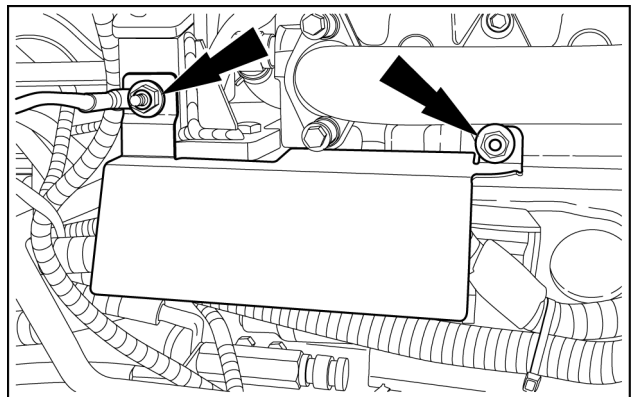

BAIL14TR00276AB 7

8. Remove the oil cooler pipe bracket.

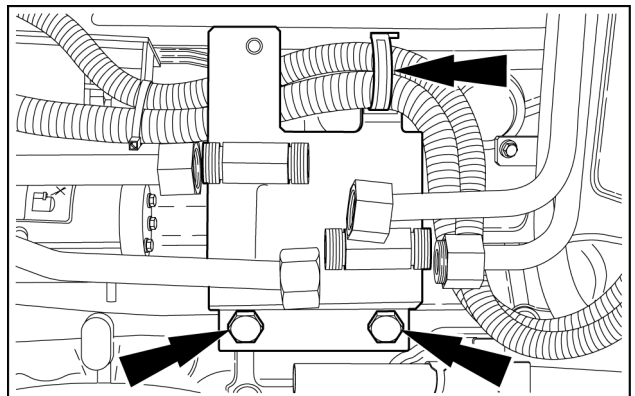

BAIL14TR00277AB 8

9. Detach the fuse box and position it to one side.

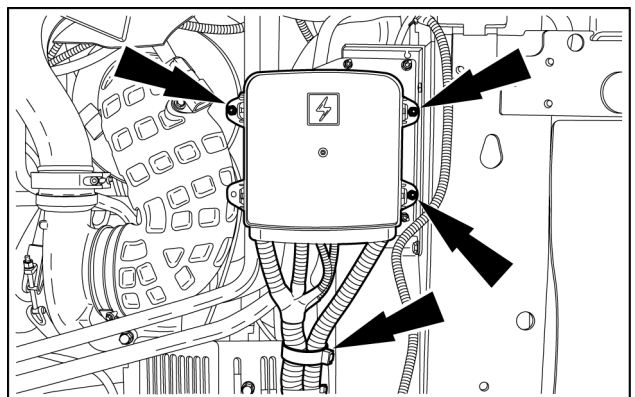

BAIL13TR01663AB 9

10. Disconnect the starter motor positive cables.

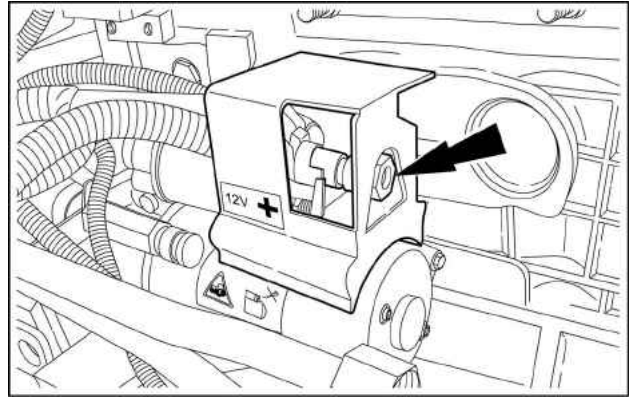

BAIL14TR00278AA 10

11. Disconnect the starter motor electrical connector.

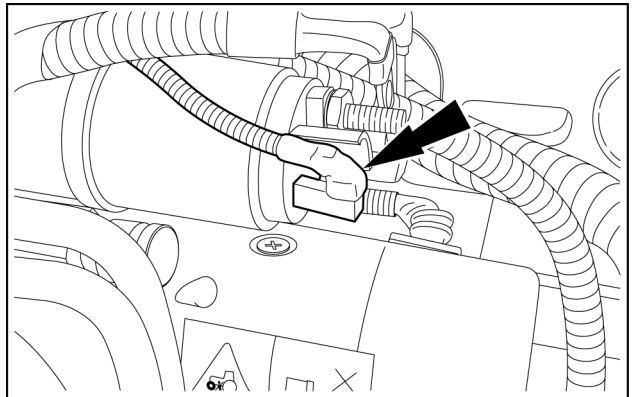

BAIL13TR01660AB 11

12. Disconnect the starter motor negative terminal.

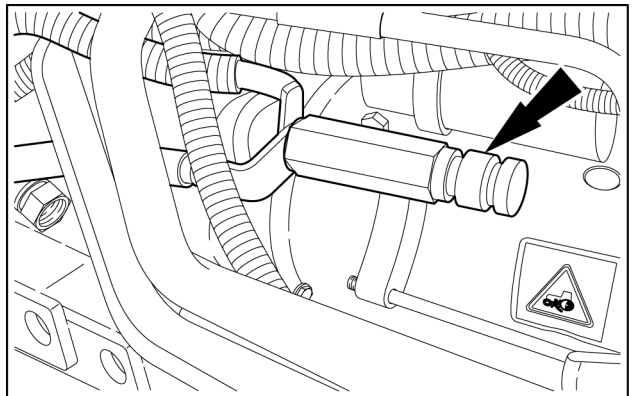

BAIL13TR01661AB 12

13. Disconnect the front axle electrical connectors.

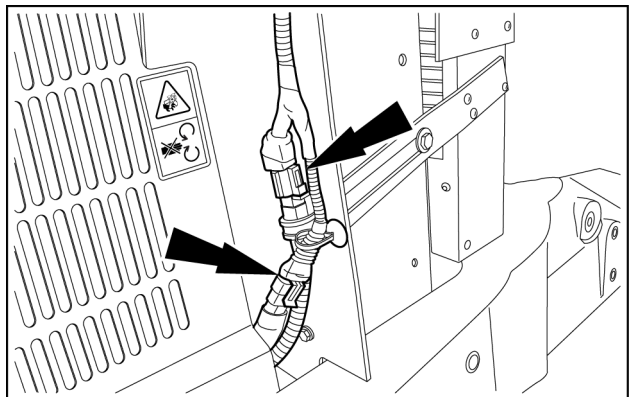

BAIL13TR01683AB 13

14. Disconnect the master cylinder oil supply pipes.

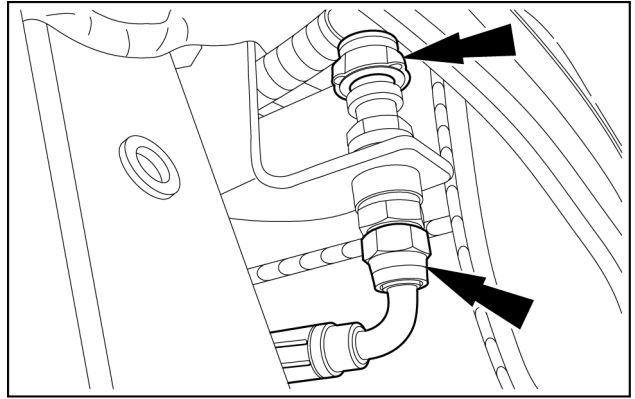

BAIL14TR00279AB 14

15. Disconnect the cab hand rail light electrical connectors (on both sides).

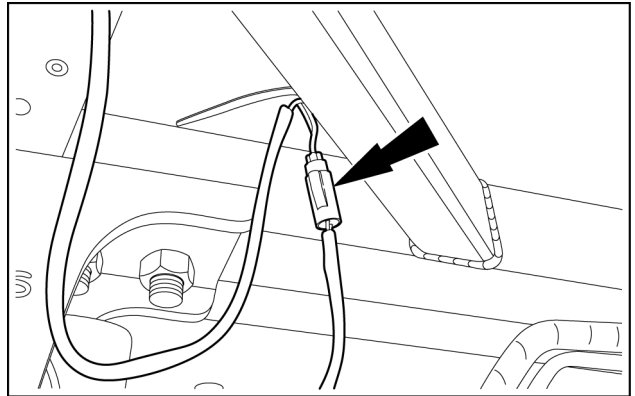

BAIL14TR00280AB 15

16. 1. Disconnect the steering pipes.
2. Disconnect the brake pipe.

NOTE: Mark the hoses to aid installation.

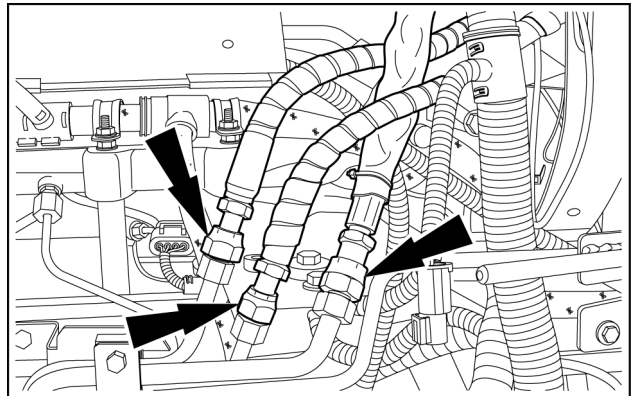

BAIL14TR00281AB 16

17. Disconnect the earth cables.

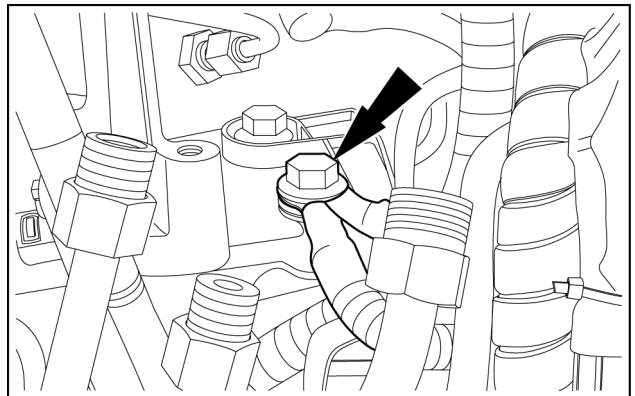

BAIL14TR00282AB 17

18. Disconnect the generator electrical connectors.

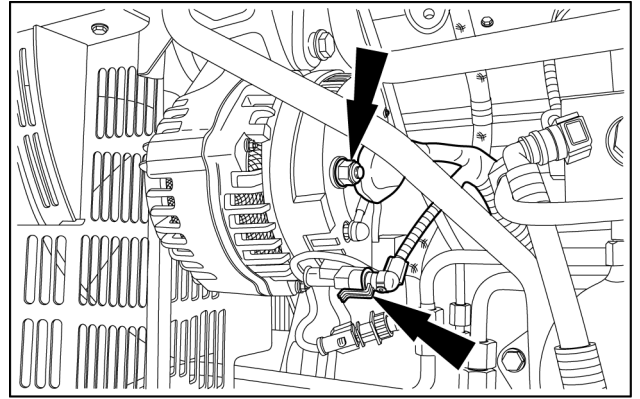

BAIL14TR00283AB 18

19. 1. Disconnect the brake accumulator electrical connector.
2. Disconnect the water-in-fuel electrical connector.

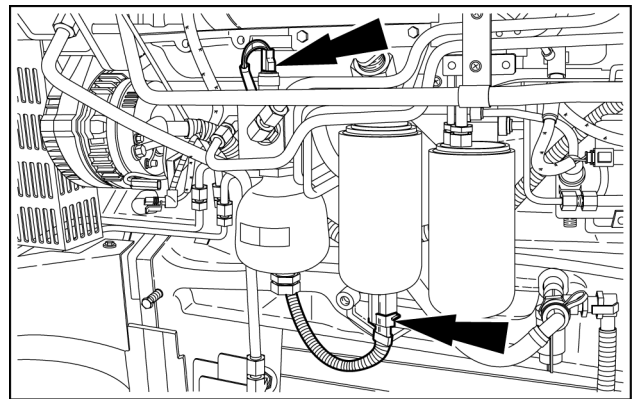

BAIL14TR00284AB 19

20. 1. Disconnect the flywheel speed sensor.
2. Disconnect the engine wiring harness.

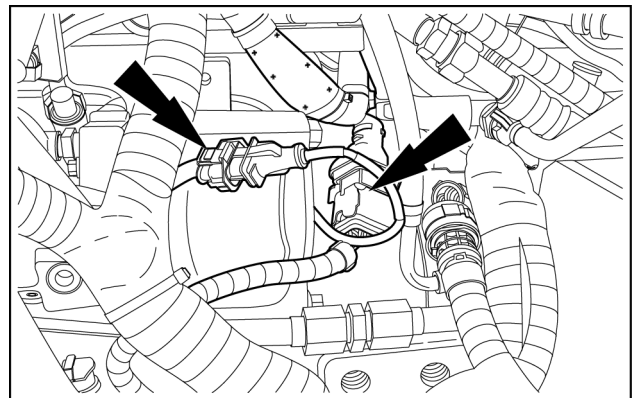

BAIL14TR00285AB 20

21. Disconnect the air conditioning (A/C) pipes.

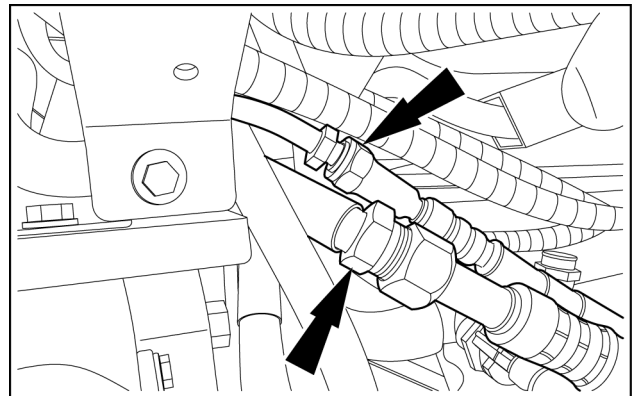

BAIL14TR00286AB 21

22. 1. Disconnect the coolant hose.
2. Disconnect the brake pipe.

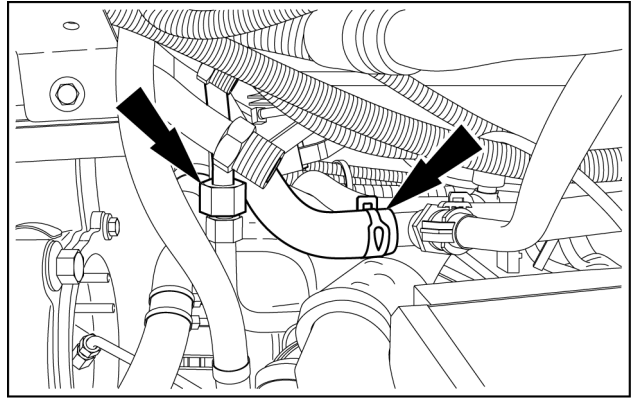

BAIL14TR00287AB 22

23. Cut the cable ties.

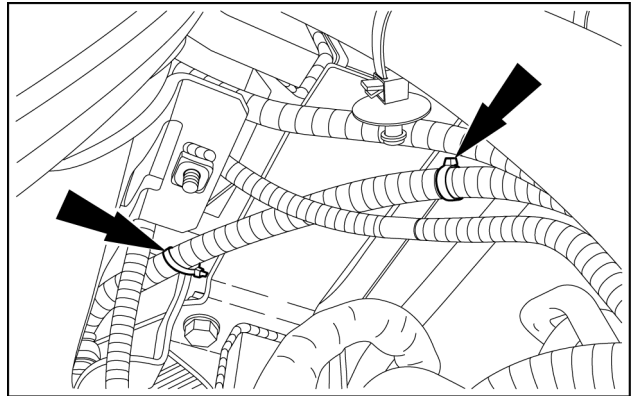

BAIL14TR00288AB 23

24. 1. Disconnect the Diesel Oxidation Catalyst (DOC) electrical connector.
2. Disconnect the hood wiring harness electrical connector.

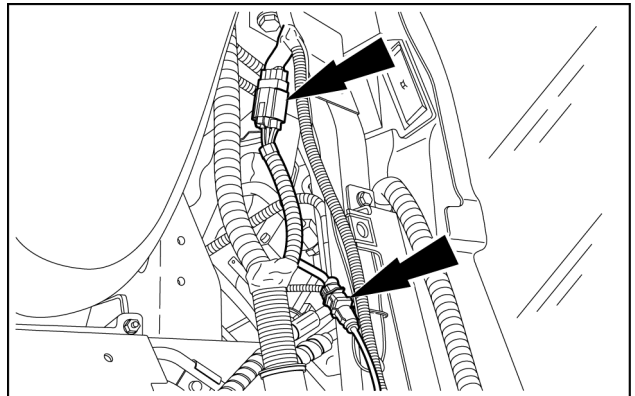

BAIL14TR00289AB 24

25. Cut the cable ties.

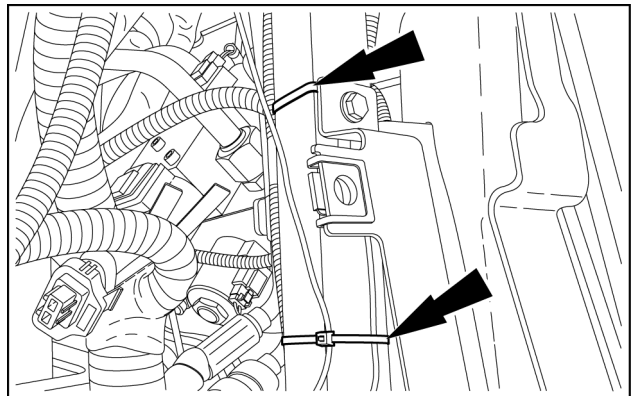

BAIL14TR00290AB 25

26. 1. Detach the DOC wiring harness and **DEF/AdBLUE®** lines.
2. Detach the engine wiring harness.

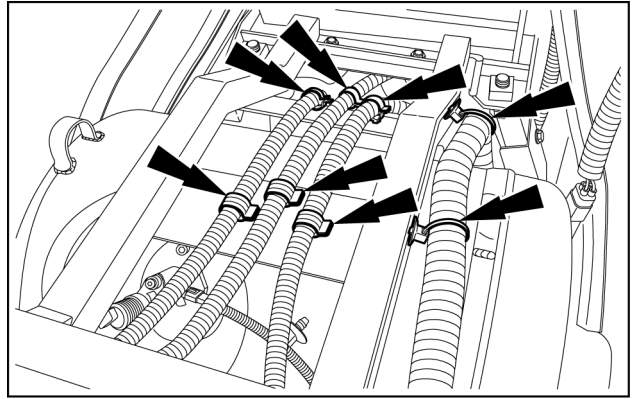

BAIL14TR00291AB 26

27. Disconnect the dosing module.
1. Disconnect the **DEF/AdBLUE®** lines.
2. Disconnect the electrical connector.

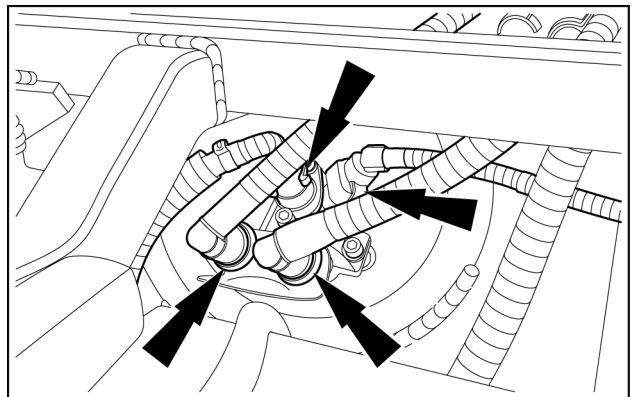

BAIL14TR00292AB 27

28. 1. Detach the wiring harness.
2. Cut the cable ties.

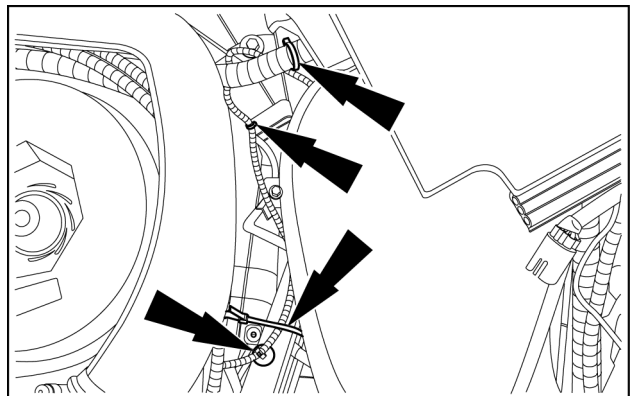

BAIL14TR00293AB 28

29. Cut the cable ties.

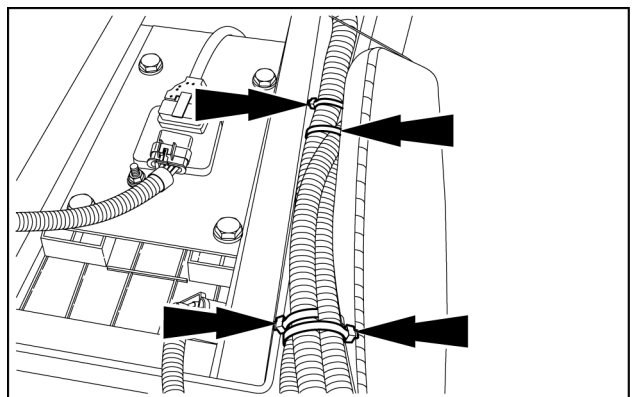

BAIL14TR00294AB 29

30. 1. Disconnect the fan electrical connector.
2. Disconnect front hitch electrical connector.

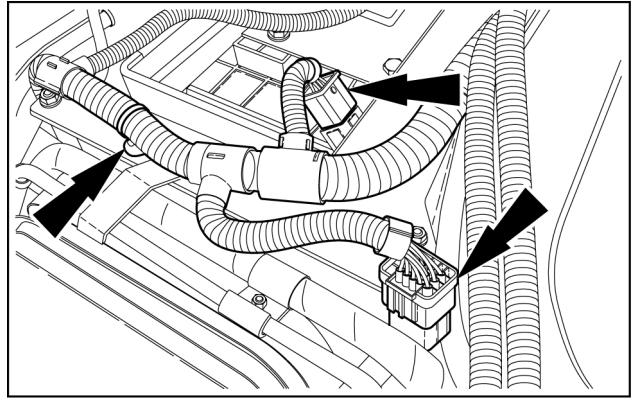

BAIL14TR00295AB 30

31. 1. Disconnect the NOx amplifier electrical connector.
2. Disconnect the coolant level sensor.

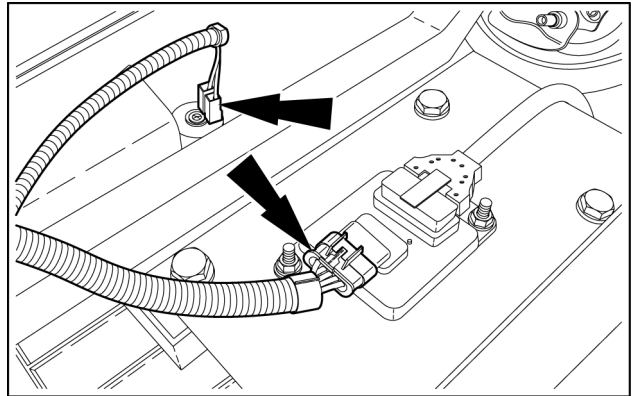

BAIL14TR00296AB 31

32. 1. Disconnect the AC pressure switch.
2. Cut the cable tie.

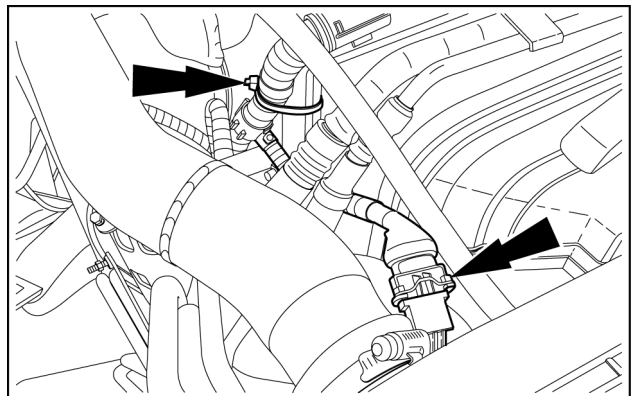

BAIL14TR00297AB 32

33. 1. Disconnect the air intake electrical connector.
2. Detach the wiring harness.

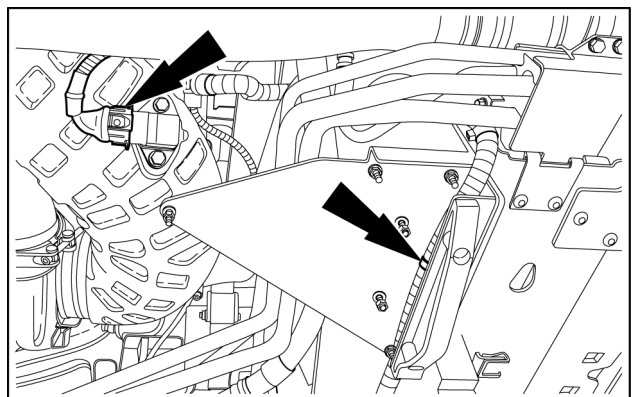

BAIL14TR00298AB 33

34. 1. Disconnect the A/C electrical connector
2. Detach the wiring harness.

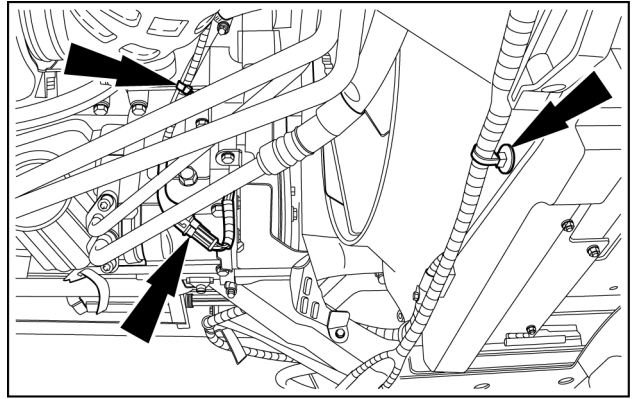

BAIL14TR00299AB 34

35. Disconnect the pneumatic trailer brake supply pipe.

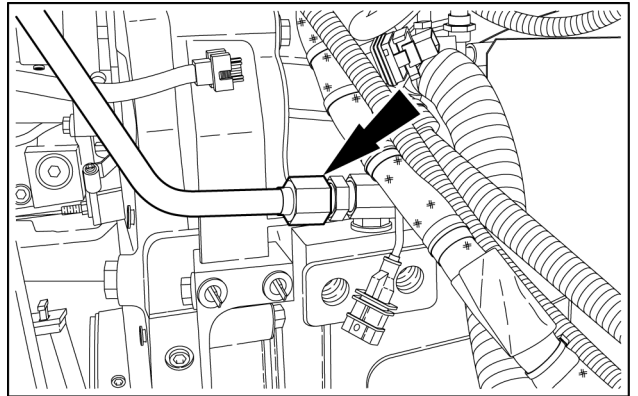

BAIL14TR00300AB 35

36. Remove the differential supply pipe.

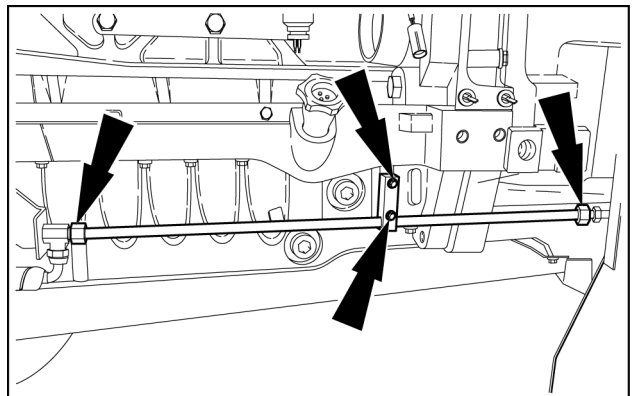

BAIL14TR00301AB 36

37. Disconnect the air intake electrical connectors.

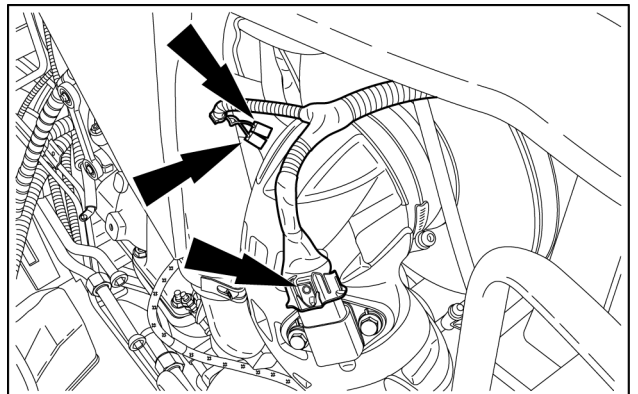

BAIL13TR01685AB 37

All vehicles

38. 1. Disconnect the differential lock supply pipe.
2. Disconnect the trailer brake air supply pipe.
3. Remove the differential lock supply pipe retaining bracket.

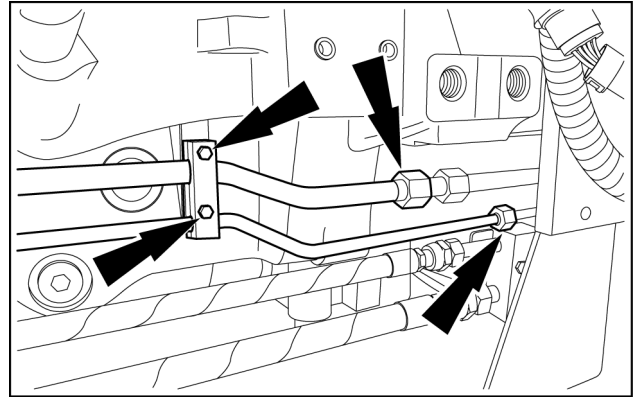

BAIL13TR01686AB 38

39. 1. Remove the differential lock supply pipe.
2. Remove the hose clamp.

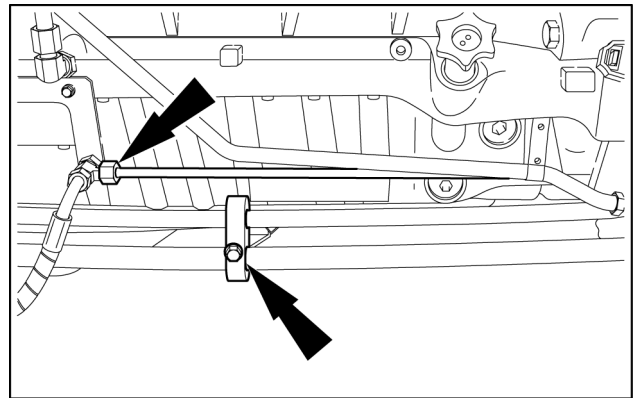

BAIL13TR01687AB 39

Vehicles with suspended front axle

40. Disconnect the front suspension hoses.

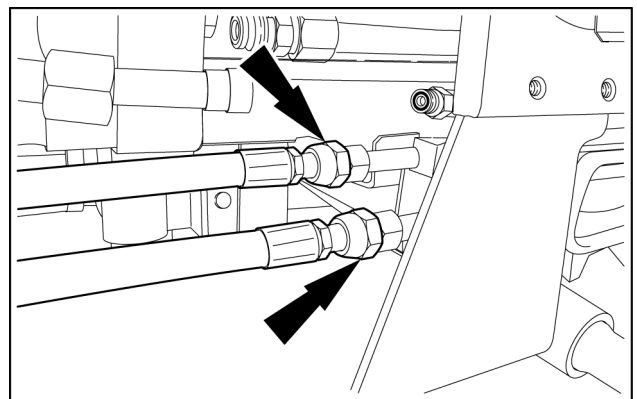

BAIL13TR01688AB 40

Vehicles with front hitch

41. Detach the front hitch external control switch.

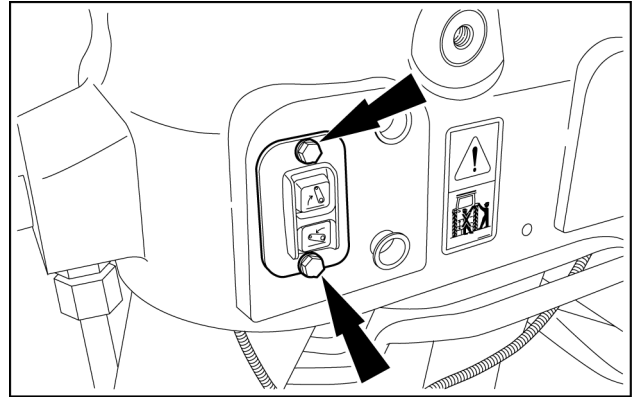

BAIL13TR01689AB 41

All vehicles

42. Using the tractor splitting stand **380003352**, install the larger wheeled part of the tractor splitting stand **380003352** under the front weight carrier and support the weight of the tractor with the splitting stand.

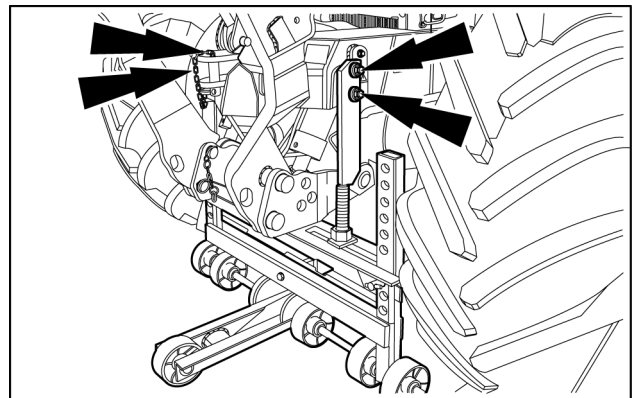

BAIL13TR01690AB 42

43. Using a suitable trolley jack, raise the front of the tractor.

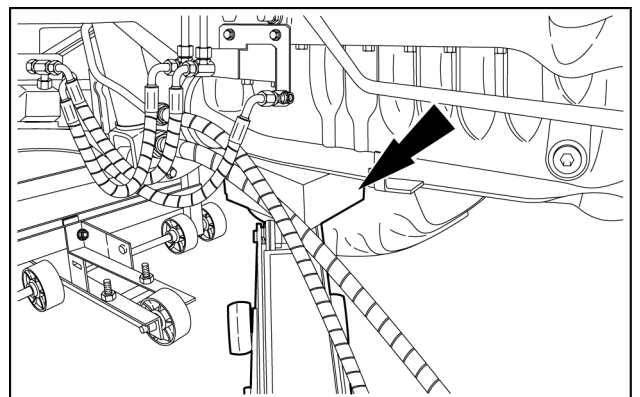

BAIL13TR01691AB 43

44. **⚠ WARNING**

Crushing hazard!
The wheels on this vehicle are very heavy. Always use a wheel remover or chain hoists to remove and install the wheels. Use an assistant as required.
Failure to comply could result in death or serious injury.

W0149A

Remove the front wheels.

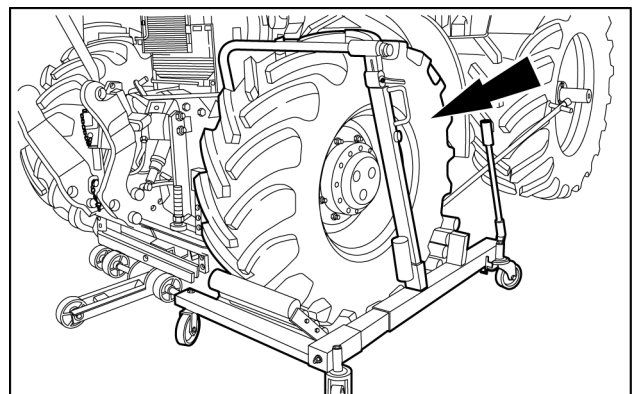

BAIL13TR01692AB 44

45. Lower the front of the tractor back onto the splitting stand.

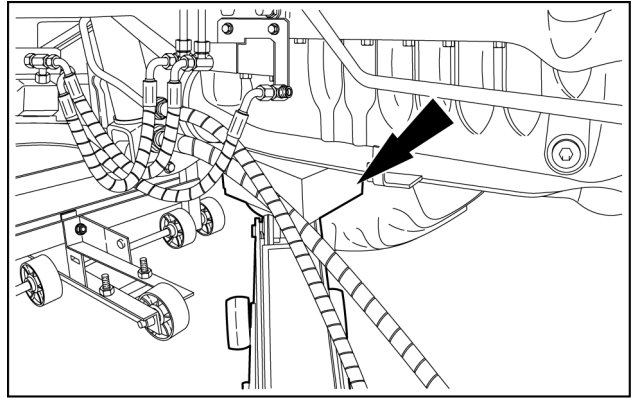

BAIL13TR01691AB 45

Vehicles with SuperSteer™ front axle

- 46.
1. Remove the front-wheel drive shaft guard retaining bolts.
 2. Remove the front wheel drive shaft guard.

NOTE: Repeat operation 1 on both sides of the vehicle.

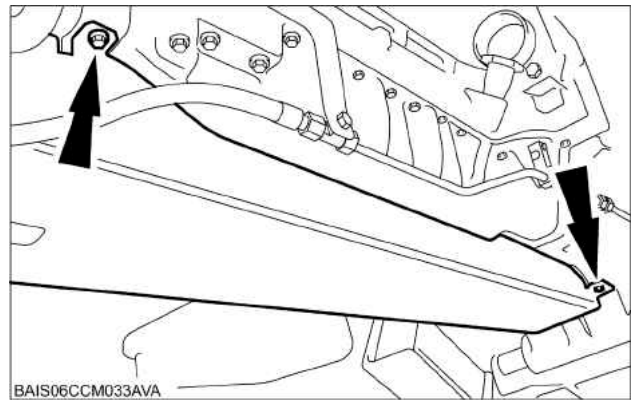

BAIS06CCM033AVA

BAIS06CCM033AVA 46

47. Remove the front-wheel drive shaft front retaining bolts.

NOTE: Support the front-wheel drive shaft.

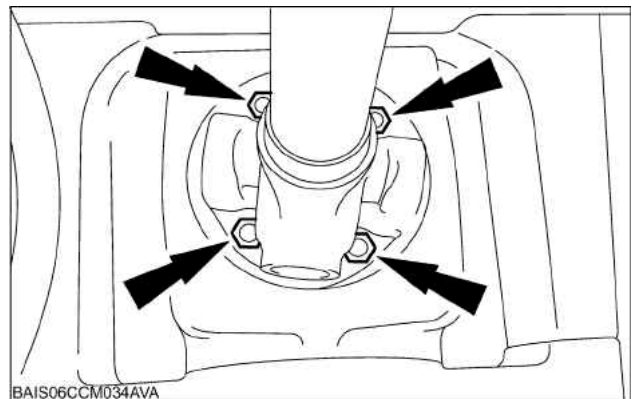

BAIS06CCM034AVA

BAIS06CCM034AVA 47

48. Remove the front wheel drive shaft.

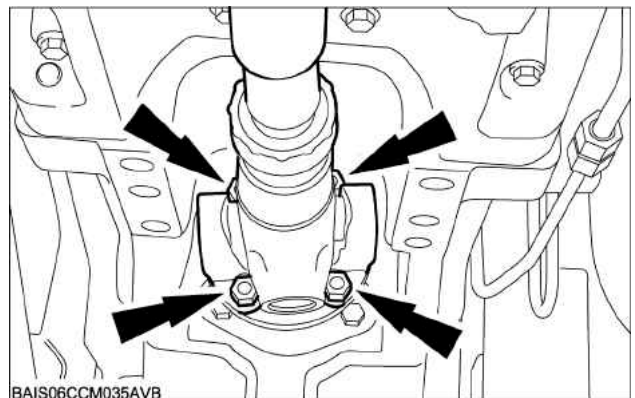

BAIS06CCM035AVB

BAIS06CCM035AVB 48

Vehicles with standard front axle

49. Remove the front wheel drive shaft guard and drive shaft.

NOTE: The type of drive shaft fitted is dependant on type of front axle installed.

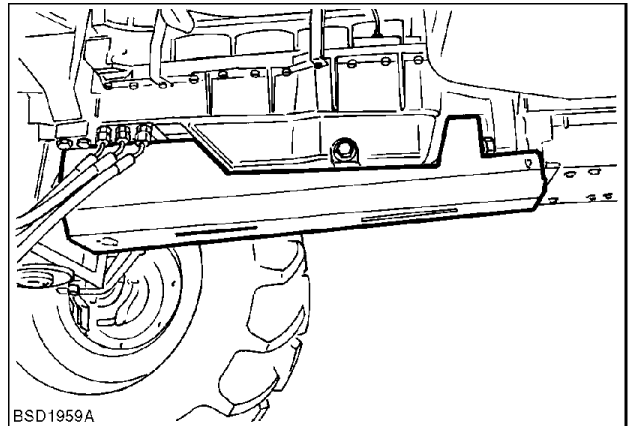

BSD1959A 49

50. Remove the drive shaft flange (where fitted).

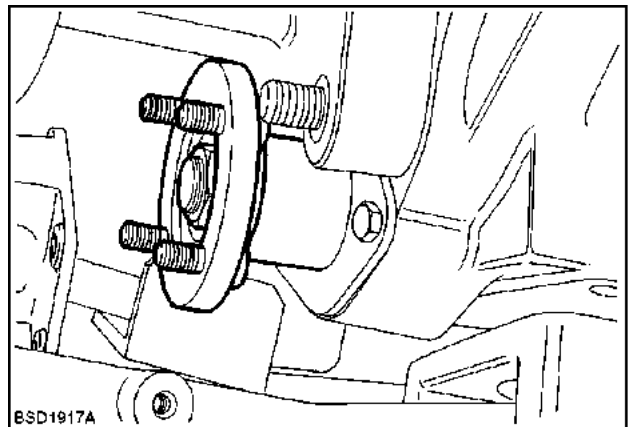

BSD1917A 50

Vehicles with suspended front axle

51. Remove the front wheel drive shaft guard.

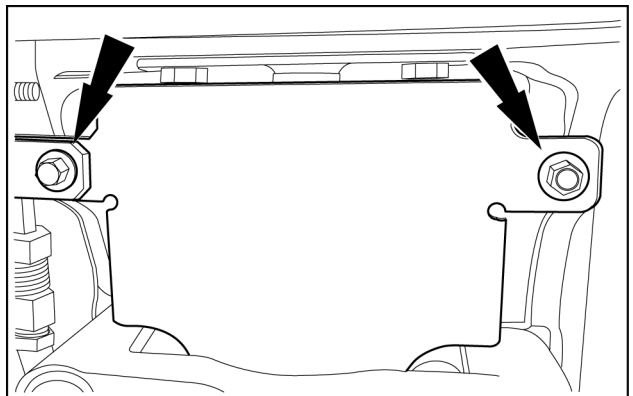

BAIL13TR01694AB 51

- 52. A. Remove the circlip (1).
- B. Slide the front wheel drive shaft sleeve (2).

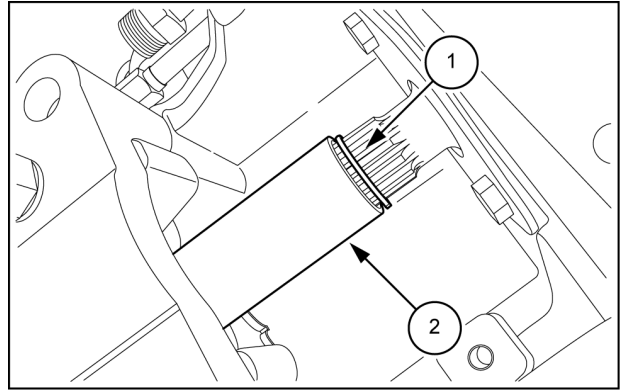

BAIL13TR01695AB 52

- 53. 1. Using a suitable trolley jack support the front axle suspension arm.
- 2. Remove the front axle suspension arm retaining bolts.
- 3. Lower the suspension arm and remove the trolley jack.

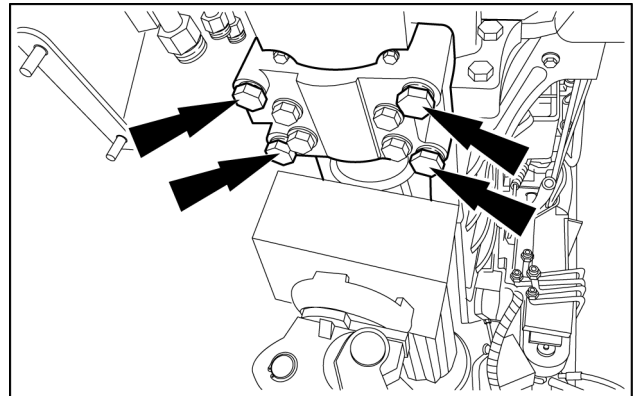

BAIL13TR01693AB 53

- 54. Install the tractor splitting stand **380003352** alignment bar to the front part of the splitting kit.

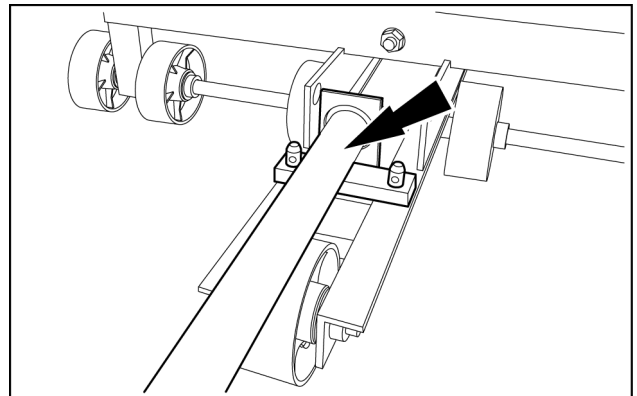

BAIL13TR01696AB 54

- 55. 1. Install the smaller wheeled part of the tractor splitting stand **380003352** under the engine.
- 2. Tighten the alignment bar bolt.

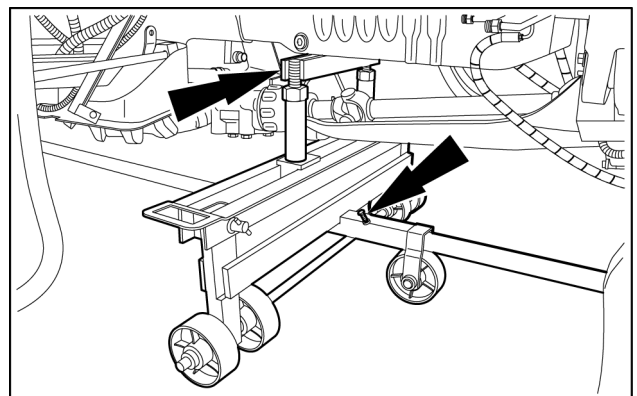

BAIL13TR01697AB 55

56. Remove the engine to transmission lower retaining bolts.

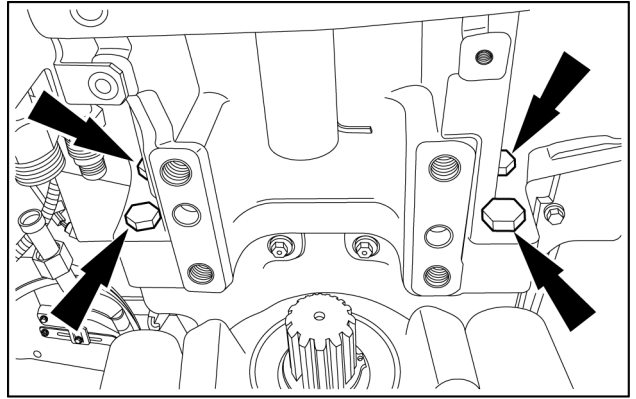

BAIL13TR01698AB 56

57. 1. Position the static part of the tractor splitting stand **380003352** under the transmission and secure to the transmission.

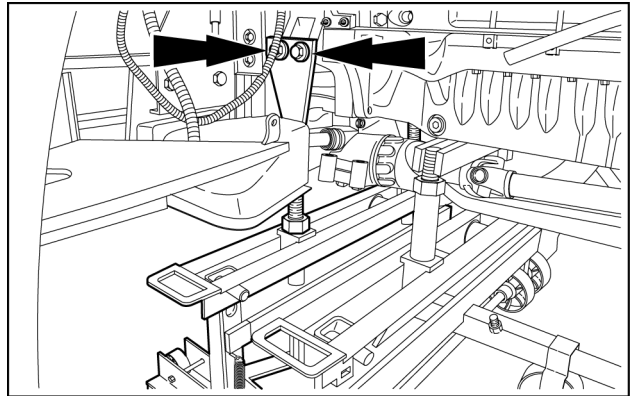

BAIL13TR01699AB 57

58. Remove the engine to transmission upper retaining bolts.

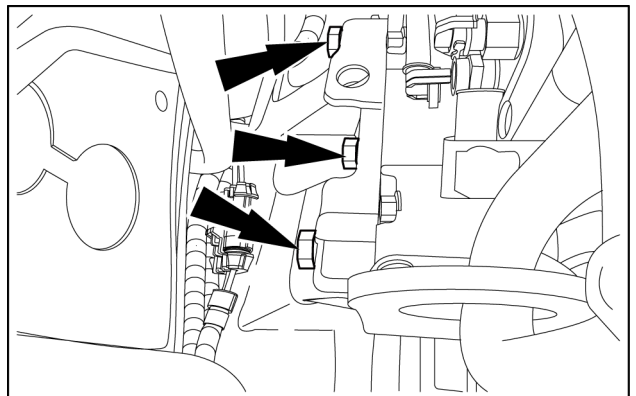

BAIL13TR00798AB 58

59. Remove the left-hand side engine to transmission retaining bolts.

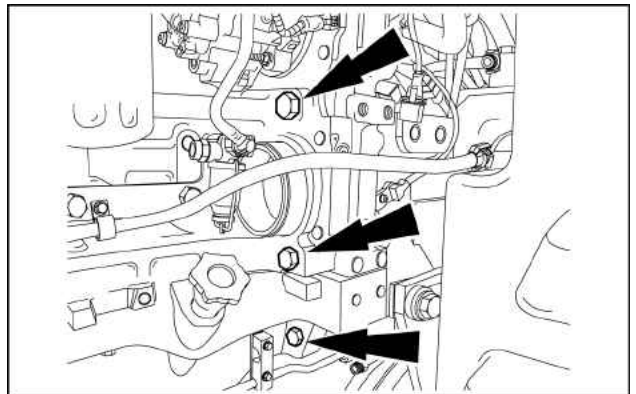

BAIL13TR00796AB 59

60. Remove the right-hand side engine to transmission retaining bolts.

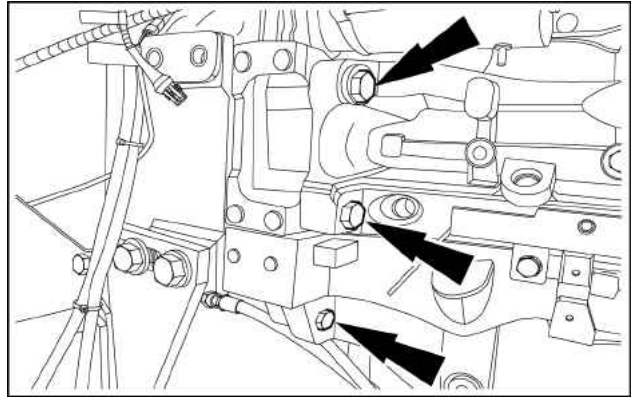

BAIL13TR00797AC 60

61. Roll the front axle and engine assembly away from the transmission.

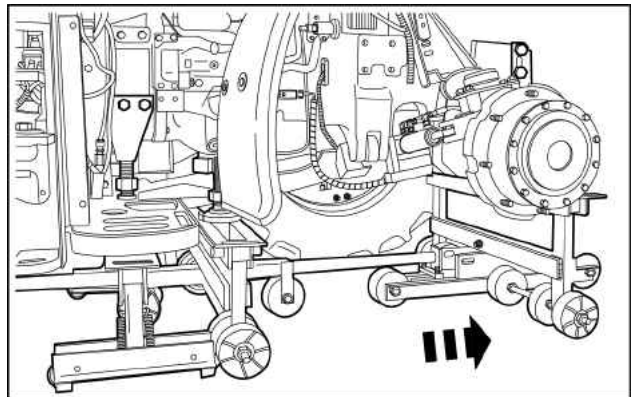

BAIL13TR00930AC 61

Engine - Install

⚠ WARNING

Heavy objects!

Lift and handle all heavy components using lifting equipment with adequate capacity. Always support units or parts with suitable slings or hooks. Make sure the work area is clear of all bystanders.

Failure to comply could result in death or serious injury.

W0398A

⚠ WARNING

Avoid injury!

Handle all parts carefully. Do not place your hands or fingers between parts. Use Personal Protective Equipment (PPE) as indicated in this manual, including protective goggles, gloves, and safety footwear.

Failure to comply could result in death or serious injury.

W0208A

1. Thoroughly clean the engine to transmission mating surfaces and apply a bead of sealant.
2. Using suitable lifting equipment, align and install the engine to the transmission.

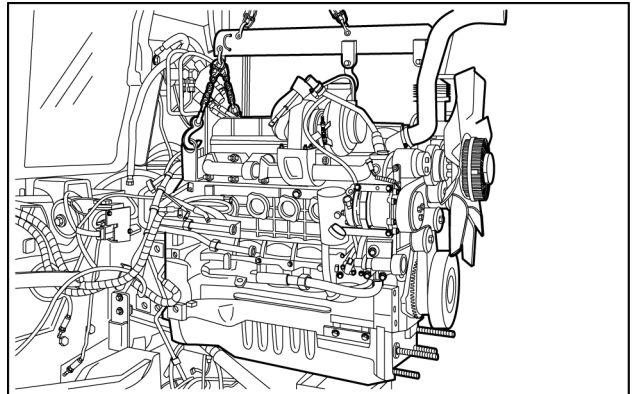

BAIL14TR00337AA 1

3. A. Install the engine to transmission right-hand side retaining bolts.
B. Torque to **285-315 Nm (210-232 lb ft)**.

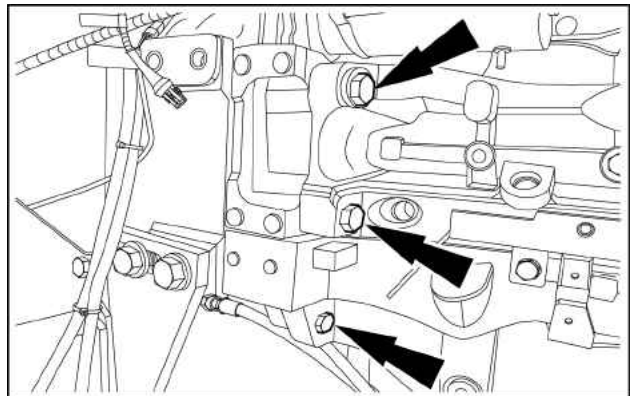

BAIL13TR00797AC 2

4. 1. Install the engine to transmission left-hand side retaining bolts.
2. Torque to **285-315 Nm (210-232 lb ft)**.

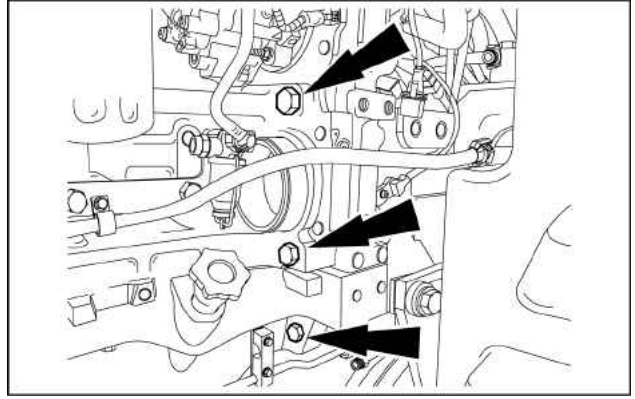

BAIL13TR00796AB 3

5. Remove the lifting equipment from the engine.

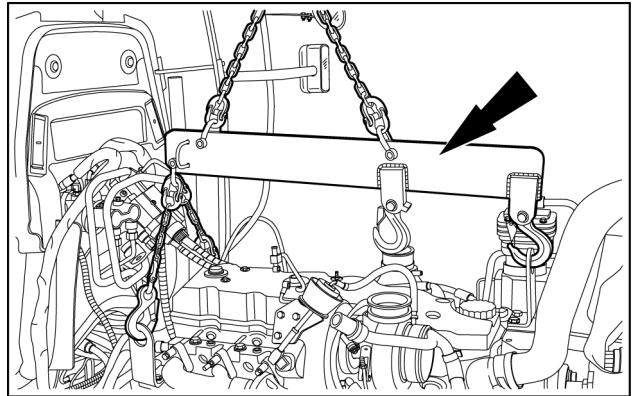

BAIL14TR00336AB 4

6. Remove the three engine lifting eyes **380200013**.

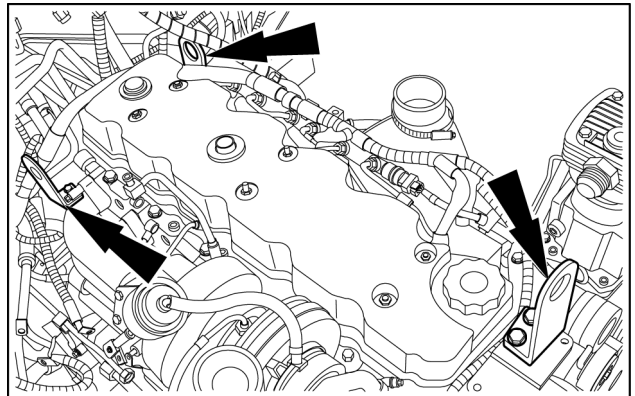

BAIL14TR00335AB 5

7. Install the engine frame front retaining bolts.

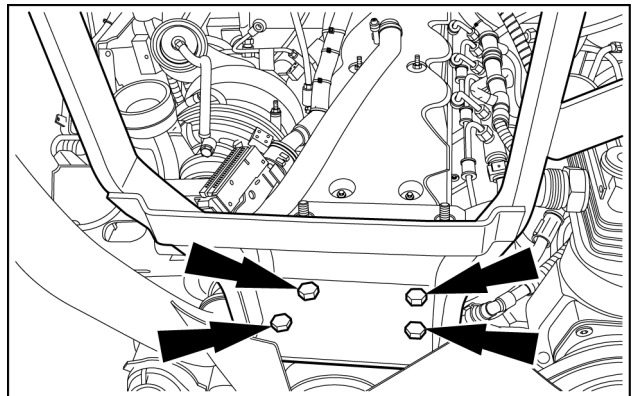

BAIL14TR00334AB 6

8. Install the air compressor intake pipe.

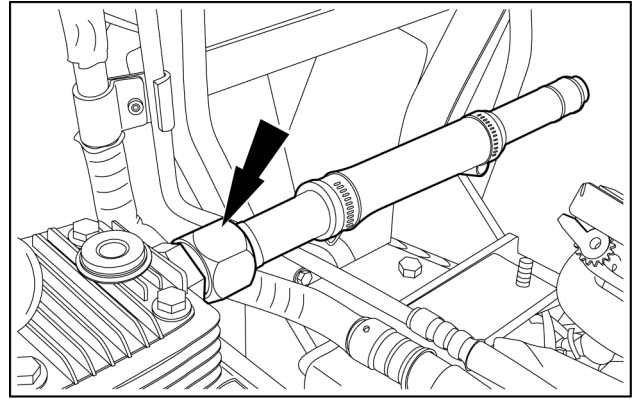

BAIL14TR00333AB 7

9. Install the air conditioning (A/C) pipes.

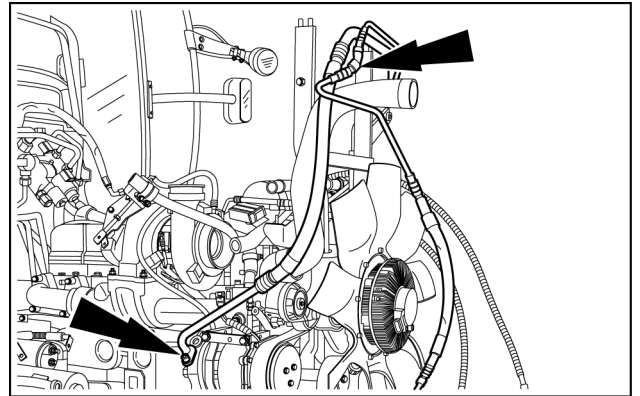

BAIL14TR00332AB 8

10. Install the rear part of the engine frame.

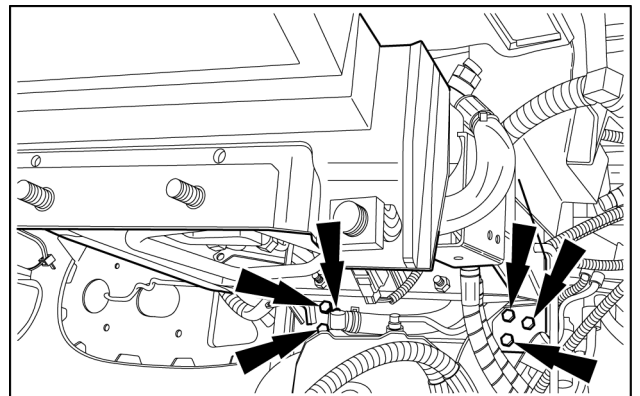

BAIL14TR00331AB 9

11. Install the engine side cover bracket.

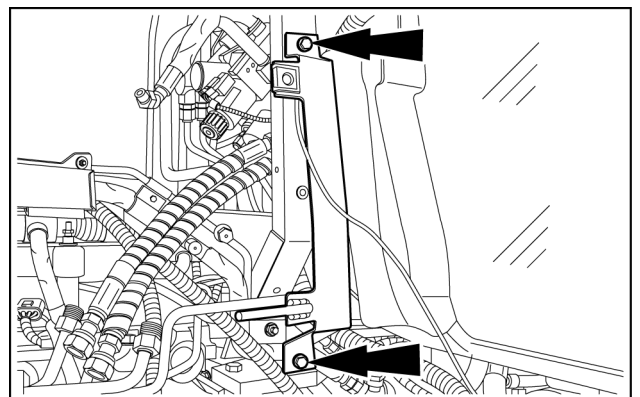

BAIL14TR00330AB 10

12. Install the lower part of the engine frame.

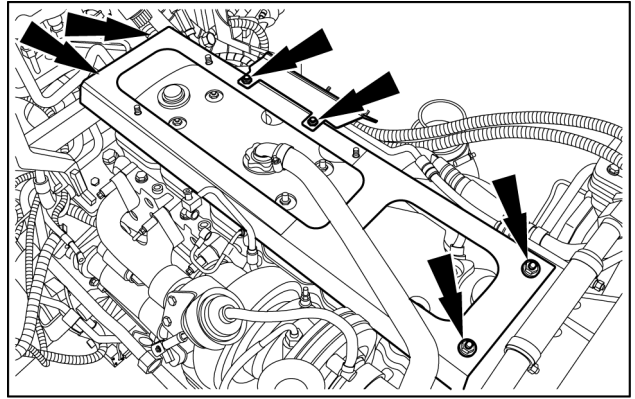

BAIL14TR00329AB 11

13. Install the DOC and frame.

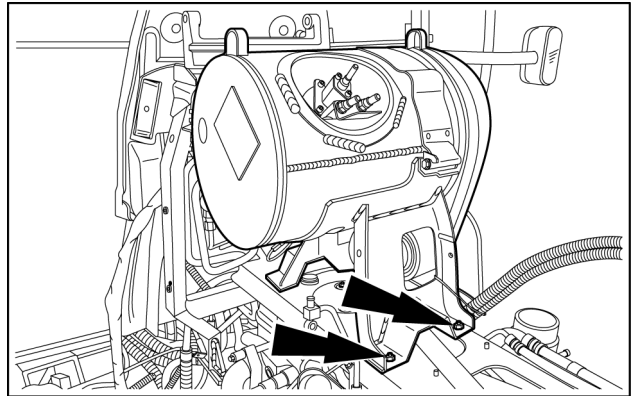

BAIL14TR00328AB 12

14. Install the exhaust flap and exhaust front pipe.

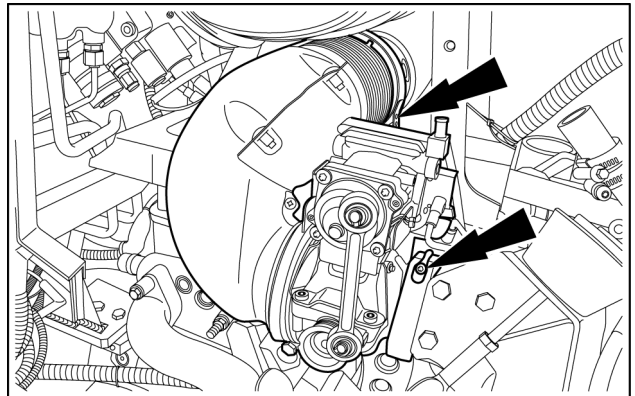

BAIL14TR00327AB 13

15. Install the DOC frame rear retaining bolts.

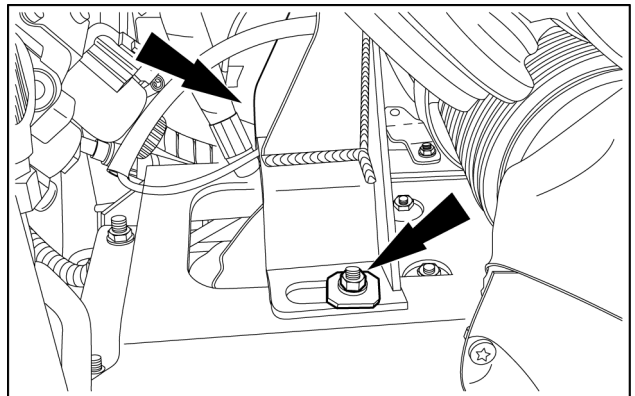

BAIL14TR00326AB 14

16. 1. Connect the coolant lines to the exhaust flap.
2. Connect the exhaust flap electrical connector.

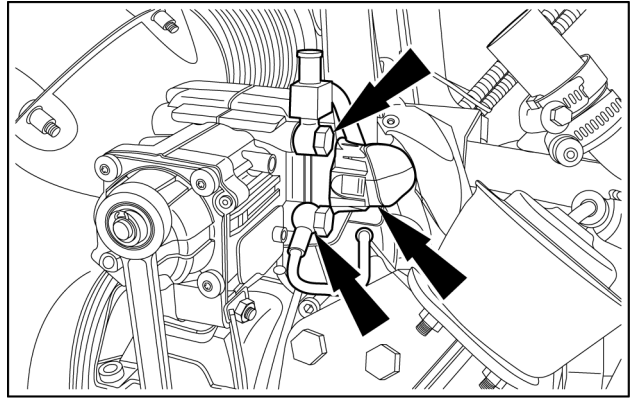

BAIL14TR00325AB 15

17. 1. Install the upper part of the engine frame.
2. Install the engine frame front retaining nuts.

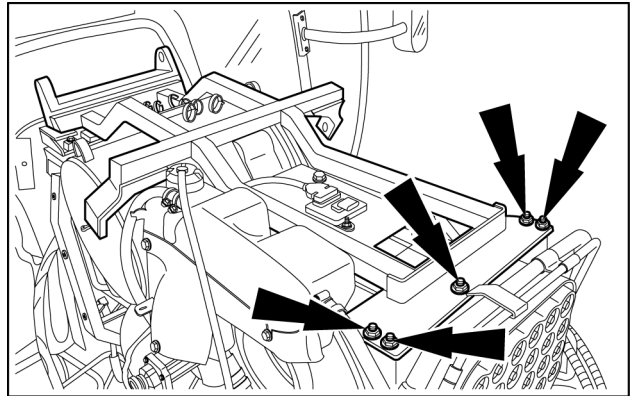

BAIL14TR00324AB 16

18. Connect the engine frame upper retaining bolts.

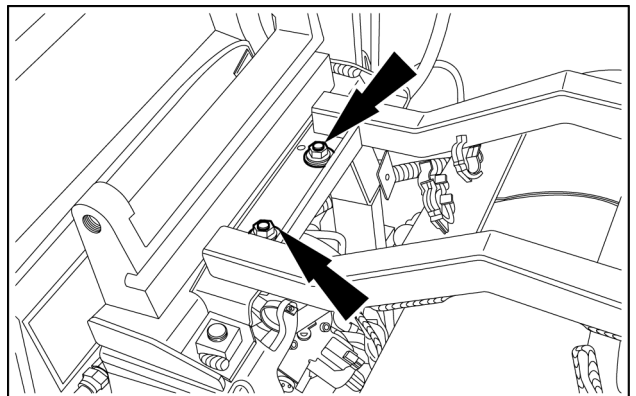

BAIL14TR00323AB 17

19. 1. Connect the coolant hose to the exhaust flap.
2. Connect the coolant expansion tank hose.
3. Install the up stream Nox sensor.

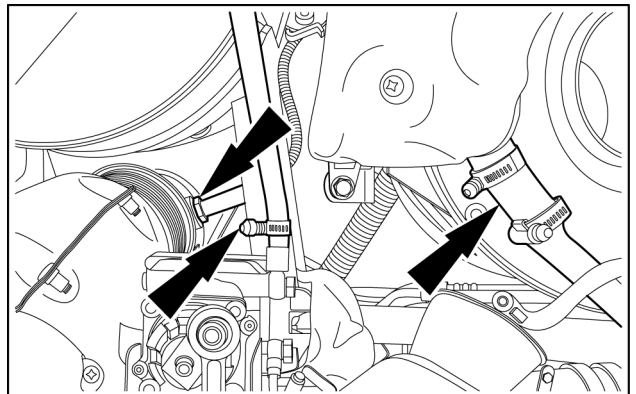

BAIL14TR00321AB 18

20. Install the air cleaner pipe.

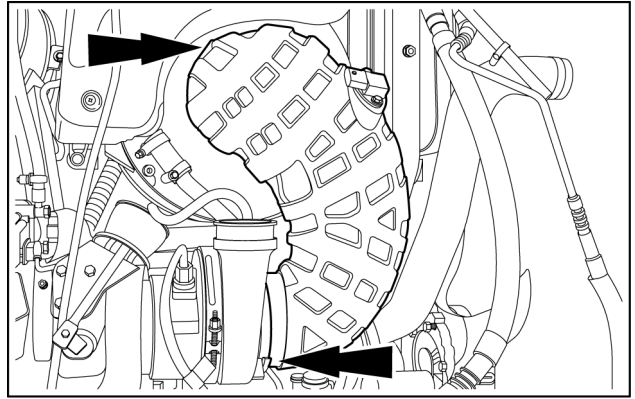

BAIL14TR00320AB 19

21. 1. Connect the air compressor supply pipe.
2. Connect the rocker cover breather pipe.

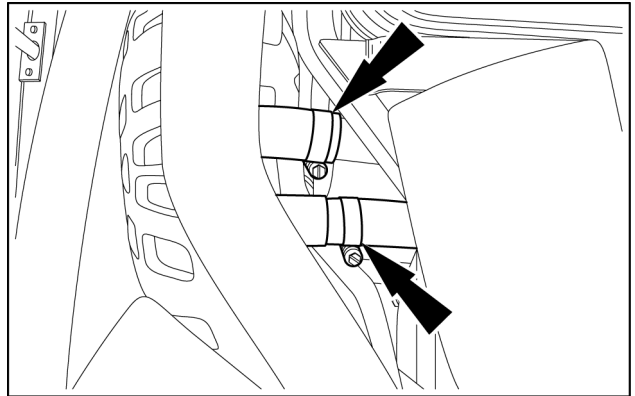

BAIL14TR00319AB 20

22. Install the left-hand air intake pipe.

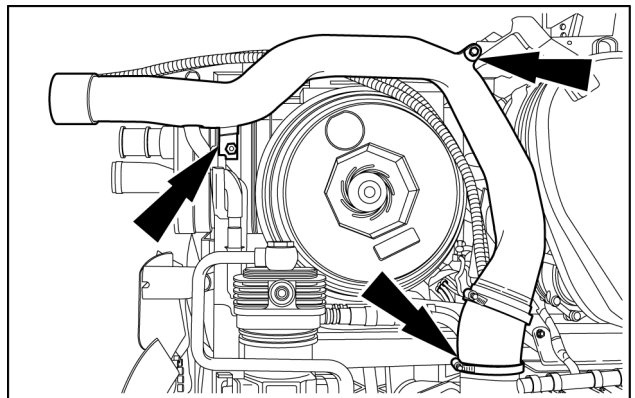

BAIL14TR00318AB 21

23. Install the right-hand air intake pipe.

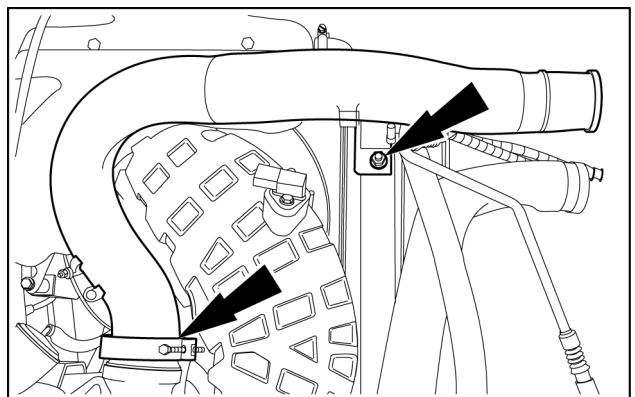

BAIL14TR00317AB 22

24. 1. Connect the air intake sensor electrical connector.
2. Connect the A/C compressor electrical connector.

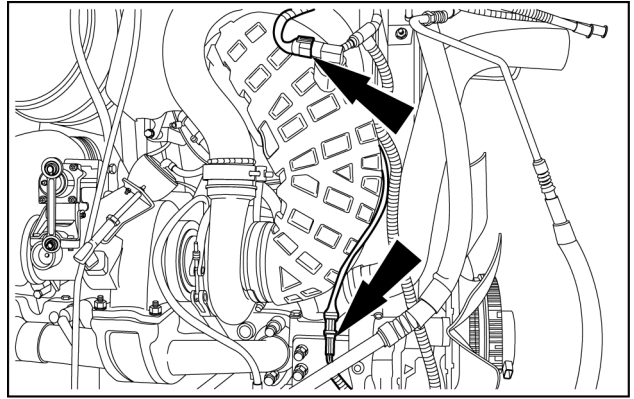

BAIL14TR00316AB 23

25. 1. Connect the AC pressure switch electrical connector.
2. Install a new cable tie.

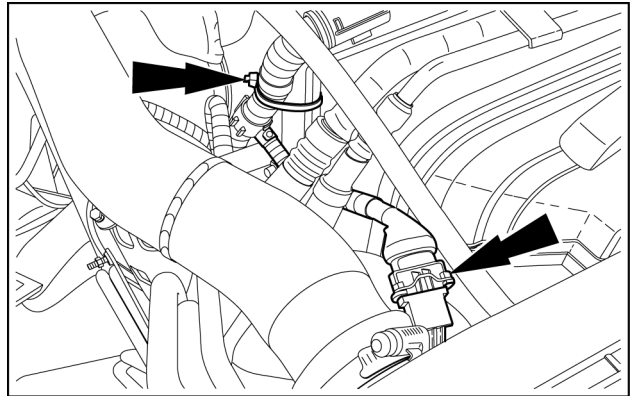

BAIL14TR00297AB 24

26. 1. Connect the NOx amplifier electrical connector.
2. Connect the coolant level sensor electrical connector.

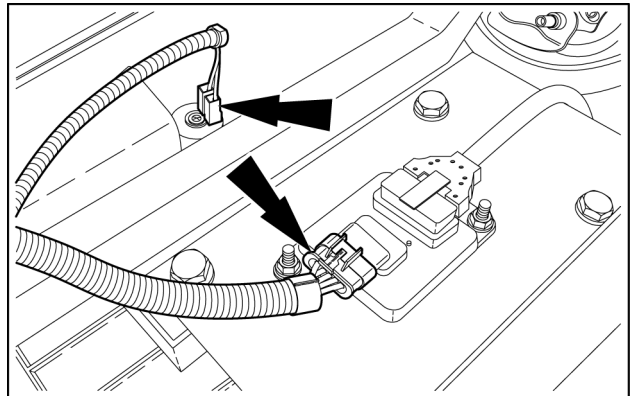

BAIL14TR00296AB 25

27. 1. Connect the fan electrical connector.
2. Connect front hitch electrical connector.

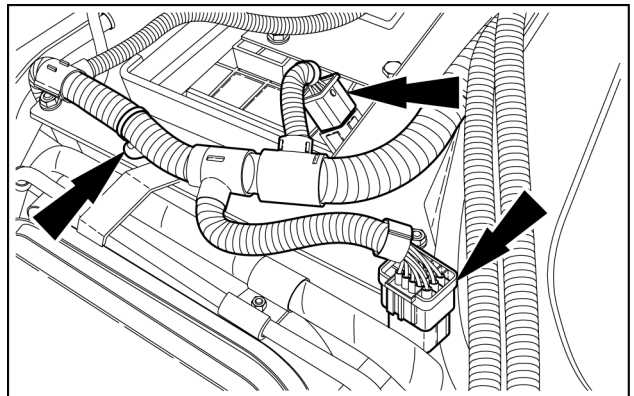

BAIL14TR00295AB 26

28. Install new cable ties.

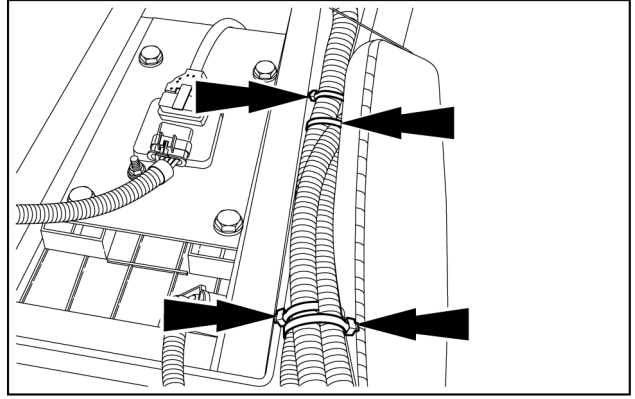

BAIL14TR00294AB 27

29. 1. Attach the wiring harness.
2. Install new cable ties.

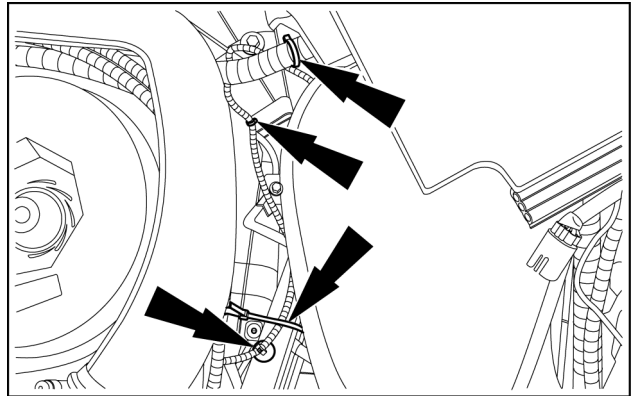

BAIL14TR00293AB 28

30. Connect the dosing module.
1. Connect the dosing module electrical connector.
2. Connect the **DEF/AdBLUE®** lines.

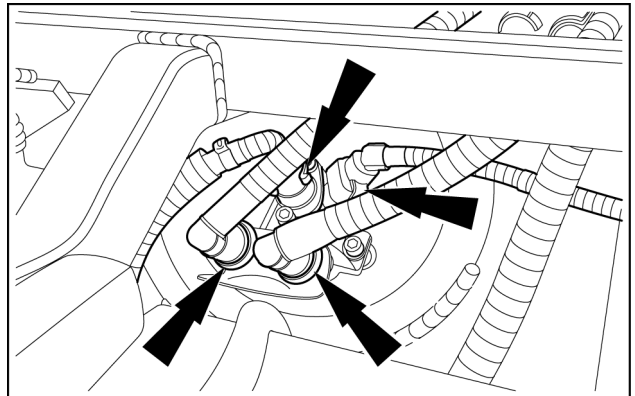

BAIL14TR00292AB 29

31. 1. Attach the DOC wiring harness and **DEF/AdBLUE®** lines.
2. Attach the wiring harness.

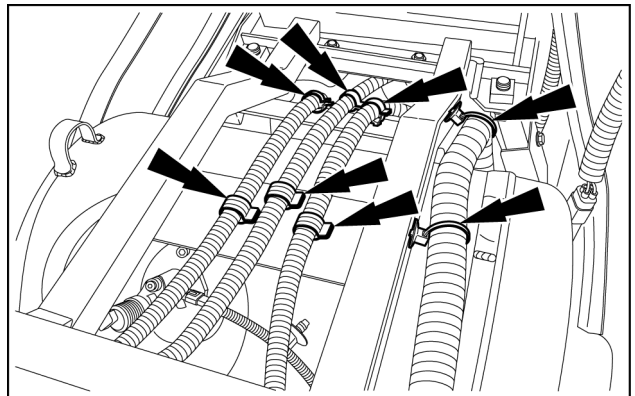

BAIL14TR00291AB 30

32. Install new cable ties.

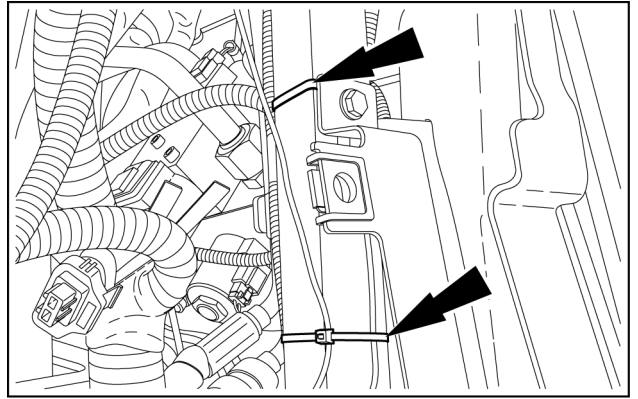

BAIL14TR00290AB 31

33. 1. Connect the Diesel Oxidation Catalyst (DOC) electrical connector.
2. Connect the hood wiring harness electrical connector.

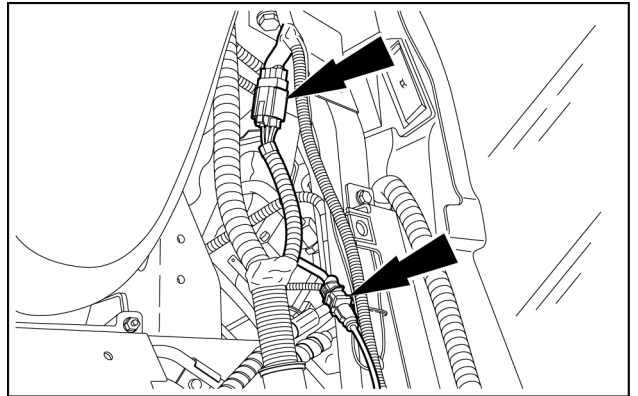

BAIL14TR00289AB 32

34. Install new cable ties.

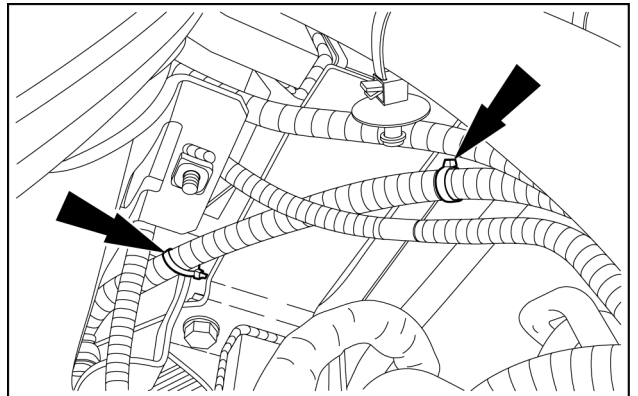

BAIL14TR00288AB 33

35. 1. Connect the coolant hose.
2. Connect the brake pipe.

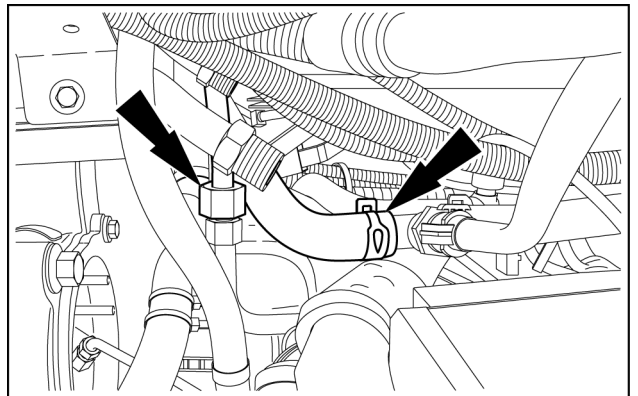

BAIL14TR00287AB 34

36. Connect the Air conditioning (A/C) pipes.

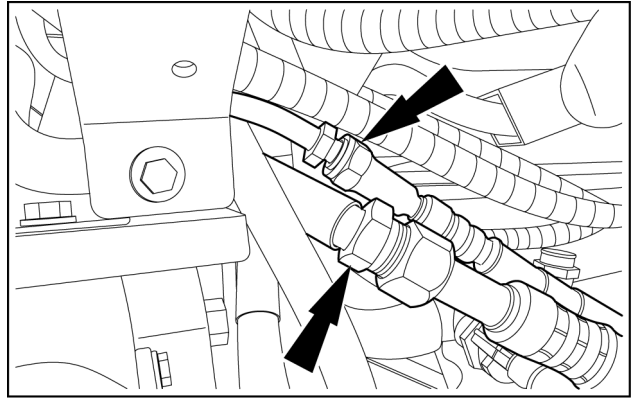

BAIL14TR00286AB 35

37. 1. Connect the flywheel speed sensor electrical connector.
2. Connect the engine wiring harness.

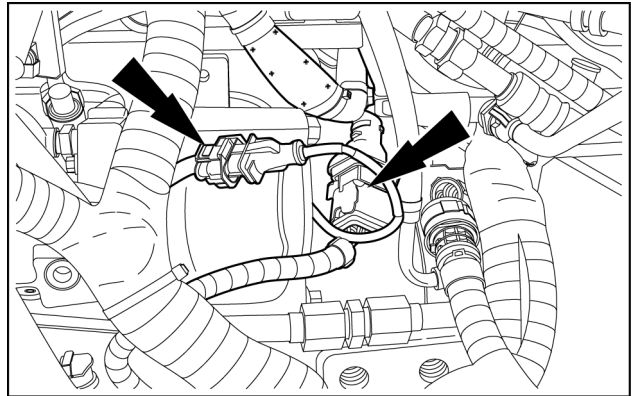

BAIL14TR00285AB 36

38. 1. Connect the brake accumulator electrical connector.
2. Connect the water-in-fuel sensor electrical connector.

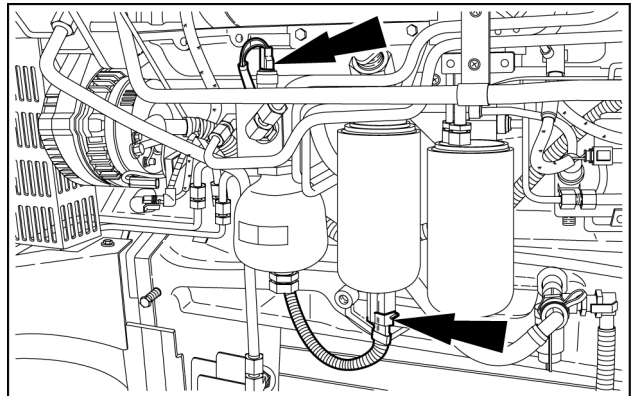

BAIL14TR00284AB 37

39. Connect the generator electrical connectors.

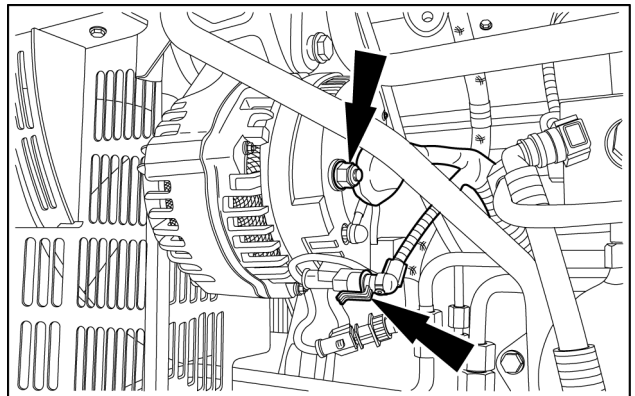

BAIL14TR00283AB 38

40. Connect the ground cables.

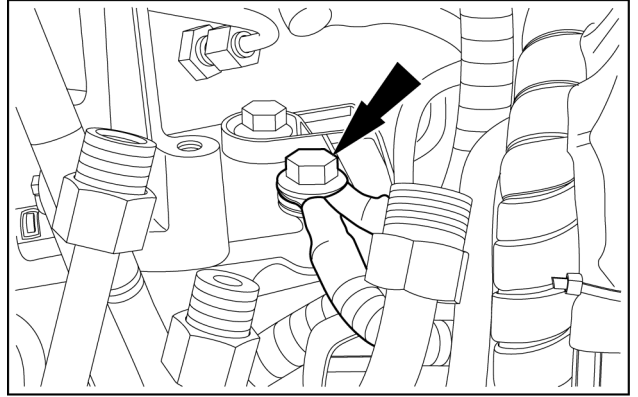

BAIL14TR00282AB 39

41. 1. Connect the steering pipes.
2. Connect the brake pipe.

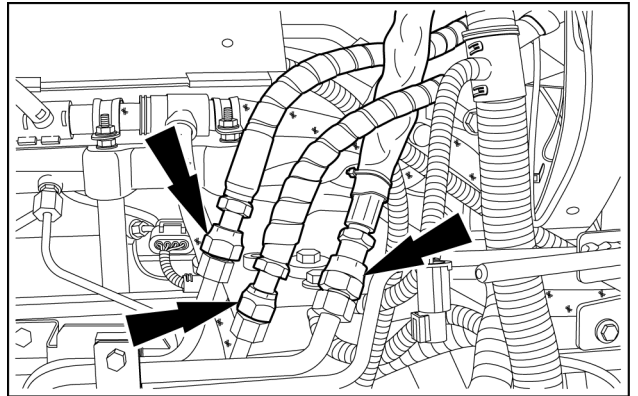

BAIL14TR00281AB 40

42. Connect the cab hand rail light electrical connectors (on both sides).

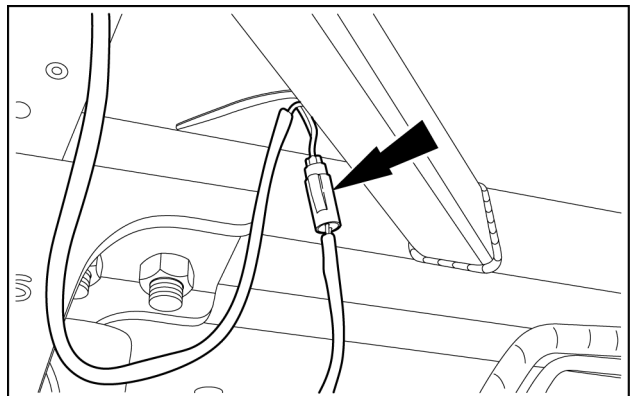

BAIL14TR00280AB 41

43. Connect the brake master cylinder oil supply pipes.

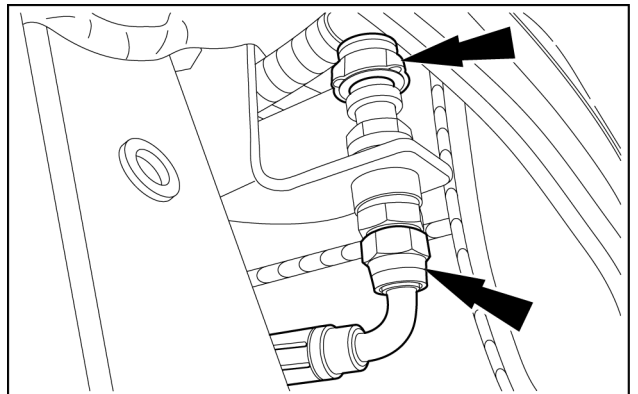

BAIL14TR00279AB 42

44. Connect the front axle electrical connectors.

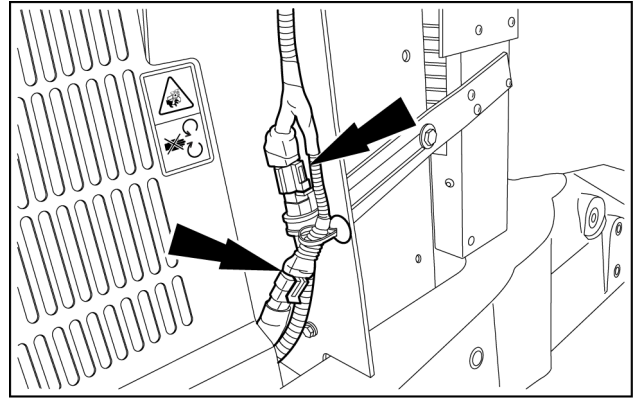

BAIL13TR01683AB 43

45. Connect the starter motor negative terminal.

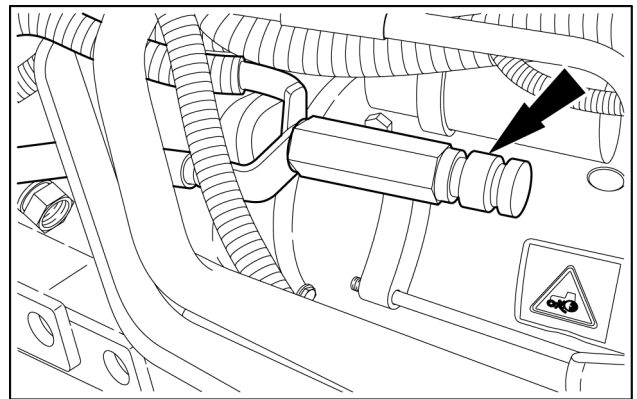

BAIL13TR01661AB 44

46. Connect the starter motor electrical connector.

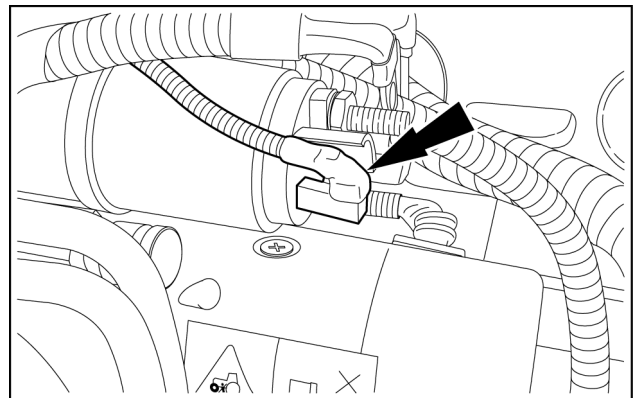

BAIL13TR01660AB 45

47. Connect the starter motor positive cables.

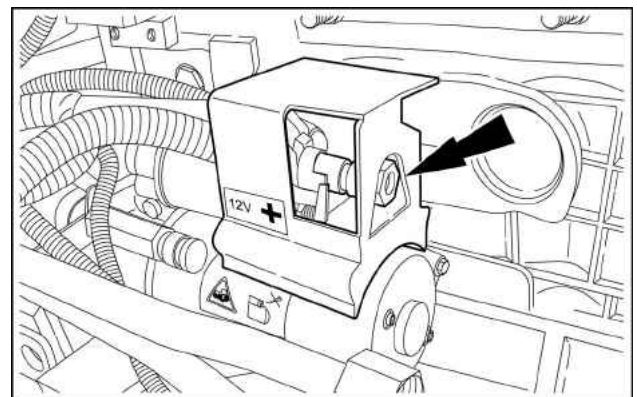

BAIL14TR00278AA 46

48. Attach the fuse box.

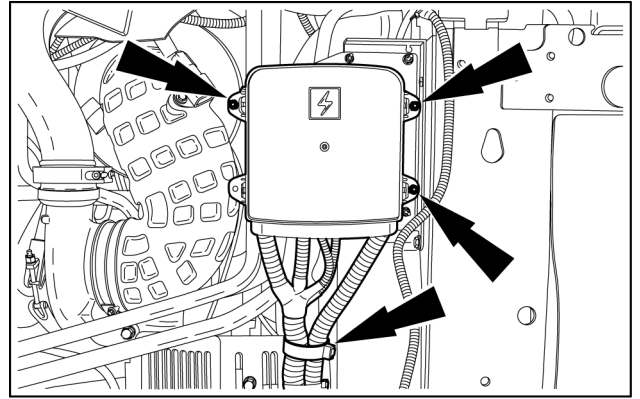

BAIL13TR01663AB 47

49. Install the oil cooler pipe bracket.

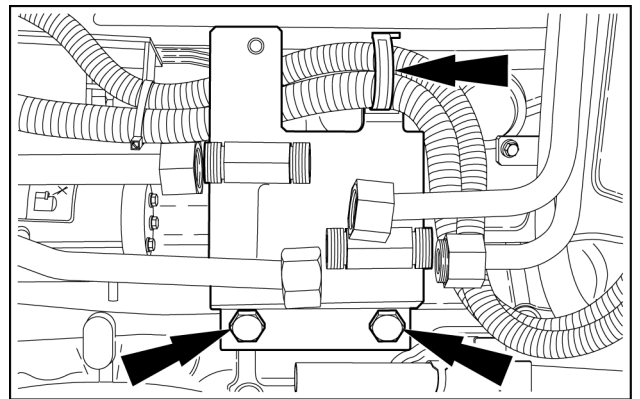

BAIL14TR00277AB 48

50. Install the starter motor cover.

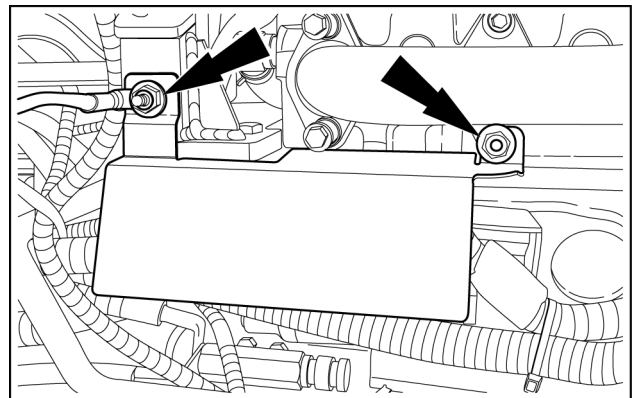

BAIL14TR00276AB 49

Vehicles with front hitch

51. Connect the mid-mount pipes to the mid-mount valve.

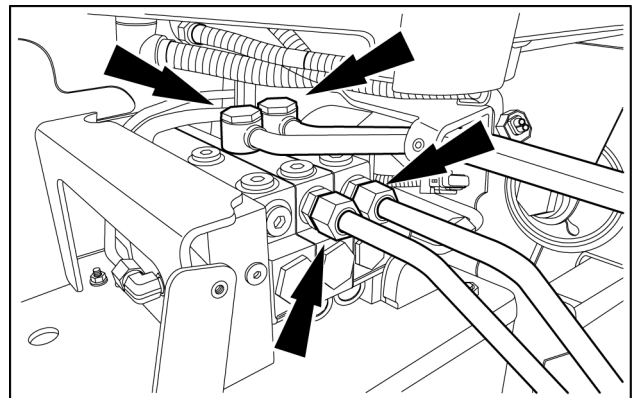

BAIL13TR01645AB 50

52. 1. Install the radar (if fitted).
2. Connect the radar electrical connector.

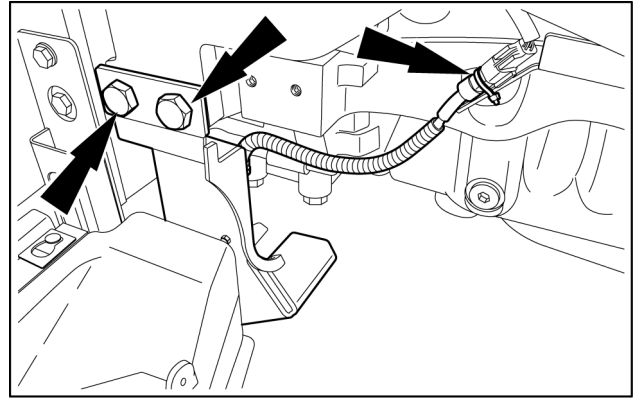

BAIL13TR01648AB 51

53. Fill the transmission with oil.

Next operation:

Install the fuel tank, for further information refer to **Fuel tank - Install (10.216)**

Next operation:

Install the SCR muffler, for further information refer to **Selective Catalytic Reduction (SCR) muffler and catalyst - Install (10.500)**

Next operation:

Install the front axle and front frame to the engine refer to **Front frame - Install (39.100)** .

Next operation:

Install the hood, for further information refer to **Hood - Install (90.100)**

Engine - Connect

NOTICE: Avoid DEF/AdBLUE® contamination of the electrical connector by connecting the DEF/AdBLUE® connectors last.

⚠ WARNING

Heavy objects!

Lift and handle all heavy components using lifting equipment with adequate capacity. Always support units or parts with suitable slings or hooks. Make sure the work area is clear of all bystanders.

Failure to comply could result in death or serious injury.

W0398A

⚠ WARNING

Avoid injury!

Handle all parts carefully. Do not place your hands or fingers between parts. Use Personal Protective Equipment (PPE) as indicated in this manual, including protective goggles, gloves, and safety footwear.

Failure to comply could result in death or serious injury.

W0208A

All vehicles

1. Thoroughly clean the engine to transmission mating surfaces.
2. Align and install the front axle and engine assembly to the transmission.

NOTE: Right-hand front wheel and front weights shown removed for clarity.

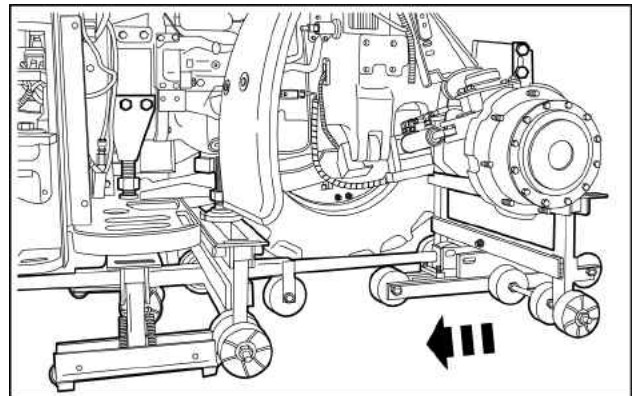

BAIL13TR00930AD 1

3. A. Install the right-hand side engine to transmission retaining bolts.
B. Torque to **285-315 Nm (210-232 lb ft)**.

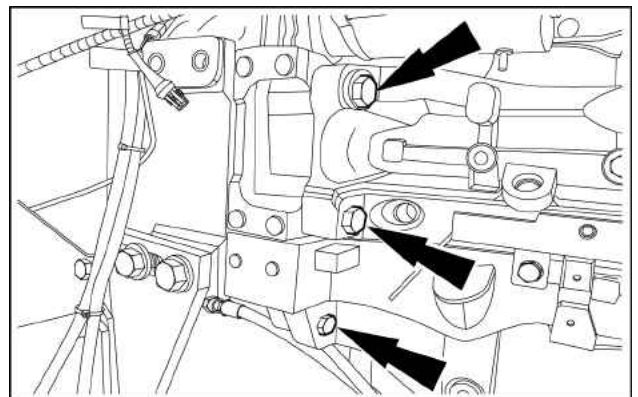

BAIL13TR00797AC 2

This as a preview PDF file from best-manuals.com



Download full PDF manual at best-manuals.com