

# SERVICE MANUAL

**Guardian™ SP.295F / Guardian™ SP.300F**

**Guardian™ SP.345F / Guardian™ SP.400F**

**Tier 4B (final)**

**Sprayer**

*PIN YFYM00001 and above*

**Part number 47691240**

1<sup>st</sup> edition English

February 2015





# **SERVICE MANUAL**

**SP.295F**

**SP.300F**

**SP.345F**

**SP.400F**

# Contents

---

## INTRODUCTION

Engine.....	10
[10.001] Engine and crankcase .....	10.1
[10.114] Pump drives .....	10.2
[10.216] Fuel tanks .....	10.3
[10.206] Fuel filters .....	10.4
[10.202] Air cleaners and lines .....	10.5
[10.500] Selective Catalytic Reduction (SCR) exhaust treatment .....	10.6
[10.400] Engine cooling system .....	10.7
[10.414] Fan and drive .....	10.8
Front axle system .....	25
[25.100] Powered front axle .....	25.1
Hydrostatic drive.....	29
[29.218] Pump and motor components.....	29.1
Brakes and controls .....	33
[33.202] Hydraulic service brakes .....	33.1
Hydraulic systems.....	35
[35.000] Hydraulic systems.....	35.1
[35.300] Reservoir, cooler, and filters.....	35.2
[35.220] Auxiliary hydraulic pump and lines .....	35.3
[35.752] Hydraulic fan drive cooling system.....	35.4
[35.610] Machine leveling control system .....	35.5
Pneumatic system .....	36
[36.100] Pneumatic system.....	36.1
[36.908] Pneumatic suspension .....	36.2
Steering.....	41

[41.101] Steering control .....	41.1
[41.216] Cylinders .....	41.2
<b>Wheels .....</b>	<b>44</b>
[44.511] Front wheels.....	44.1
[44.520] Rear wheels .....	44.2
<b>Cab climate control .....</b>	<b>50</b>
[50.100] Heating .....	50.1
[50.104] Ventilation .....	50.2
[50.200] Air conditioning.....	50.3
<b>Electrical systems .....</b>	<b>55</b>
[55.000] Electrical system .....	55.1
[55.100] Harnesses and connectors.....	55.2
[55.015] Engine control system.....	55.3
[55.201] Engine starting system .....	55.4
[55.301] Alternator.....	55.5
[55.302] Battery.....	55.6
[55.640] Electronic modules .....	55.7
[55.050] Heating, Ventilation, and Air-Conditioning (HVAC) control system.....	55.8
[55.047] Steering control system .....	55.9
<b>Spraying .....</b>	<b>78</b>
[78.110] Chemical spraying.....	78.1
[78.111] Spraying pump .....	78.2
[78.120] Foam marking system.....	78.3
<b>Platform, cab, bodywork, and decals .....</b>	<b>90</b>
[90.151] Cab interior.....	90.1
[90.120] Mechanically-adjusted operator seat.....	90.2
[90.100] Engine hood and panels .....	90.3

[90.116] Fenders and guards ..... 90.4



# INTRODUCTION

# Contents

---

## INTRODUCTION

Foreword - Important notice regarding equipment servicing .....	3
Safety rules .....	4
Personal safety .....	5
Safety rules - Ecology and the environment .....	14
Basic instructions - Shop and assembly .....	15
Torque - Minimum tightening torques for normal assembly .....	17
Torque - Standard torque data for hydraulics .....	20
Maintenance chart .....	22
Hydraulic contamination .....	24
Capacities .....	25
General specification .....	26
Product identification - Sprayer model and serial number .....	30
Product identification - Machine orientation .....	31

---

## **Foreword - Important notice regarding equipment servicing**

All repair and maintenance work listed in this manual must be carried out only by qualified dealership personnel, strictly complying with the instructions given, and using, whenever possible, the special tools.

Anyone who performs repair and maintenance operations without complying with the procedures provided herein shall be responsible for any subsequent damages.

The manufacturer and all the organizations of its distribution chain, including - without limitation - national, regional, or local dealers, reject any responsibility for damages caused by parts and/or components not approved by the manufacturer, including those used for the servicing or repair of the product manufactured or marketed by the manufacturer. In any case, no warranty is given or attributed on the product manufactured or marketed by the manufacturer in case of damages caused by parts and/or components not approved by the manufacturer.

The manufacturer reserves the right to make improvements in design and changes in specifications at any time without notice and without incurring any obligation to install them on units previously sold. Specifications, descriptions, and illustrative material herein are as accurate as known at time of publication but are subject to change without notice.

In case of questions, refer to your NEW HOLLAND Sales and Service Networks.



## Safety rules

### Personal safety





This is the safety alert symbol. It is used to alert you to potential personal injury hazards. Obey all safety messages that follow this symbol to avoid possible death or injury.

Throughout this manual you will find the signal words DANGER, WARNING, and CAUTION followed by special instructions. These precautions are intended for the personal safety of you and those working with you.

Read and understand all the safety messages in this manual before you operate or service the machine.

 DANGER indicates a hazardous situation that, if not avoided, will result in death or serious injury.

 WARNING indicates a hazardous situation that, if not avoided, could result in death or serious injury.

 CAUTION indicates a hazardous situation that, if not avoided, could result in minor or moderate injury.

**FAILURE TO FOLLOW DANGER, WARNING, AND CAUTION MESSAGES COULD RESULT IN DEATH OR SERIOUS INJURY.**

### Machine safety

**NOTICE:** Notice indicates a situation that, if not avoided, could result in machine or property damage.

Throughout this manual you will find the signal word Notice followed by special instructions to prevent machine or property damage. The word Notice is used to address practices not related to personal safety.

### Information

**NOTE:** Note indicates additional information that clarifies steps, procedures, or other information in this manual.

Throughout this manual you will find the word Note followed by additional information about a step, procedure, or other information in the manual. The word Note is not intended to address personal safety or property damage.

---

## Personal safety

### General safety rules

Use caution when operating the machine on slopes. Raised equipment, full tanks and other loads will change the center of gravity of the machine. The machine can tip or roll over when near ditches and embankments or uneven surfaces.

Never permit anyone other than the operator to ride on the machine.

Never operate the machine under the influence of alcohol, drugs, or while otherwise impaired.

Pay attention to overhead power lines and hanging obstacles. High voltage lines may require significant clearance for safety.

Hydraulic oil or diesel fuel leaking under pressure can penetrate the skin, causing serious injury or infection.

- DO NOT use your hand to check for leaks. Use a piece of cardboard or paper.
- Stop engine, remove key and relieve the pressure before connecting or disconnecting fluid lines.
- Make sure all components are in good condition and tighten all connections before starting the engine or pressurizing the system.
- If hydraulic fluid or diesel fuel penetrates the skin, seek medical attention immediately.
- Continuous long term contact with hydraulic fluid may cause skin cancer. Avoid long term contact and wash the skin promptly with soap and water.

Keep clear of moving parts. Loose clothing, jewelry, watches, long hair, and other loose or hanging items can become entangled in moving parts.

Wear protective equipment when appropriate.

DO NOT attempt to remove material from any part of the machine while it is being operated or components are in motion.

Make sure all guards and shields are in good condition and properly installed before operating the machine. Never operate the machine with shields removed. Always close access doors or panels before operating the machine.

Dirty or slippery steps, ladders, walkways, and platforms can cause falls. Make sure these surfaces remain clean and clear of debris.

A person or pet within the operating area of a machine can be struck or crushed by the machine or its equipment. DO NOT allow anyone to enter the work area.

Raised equipment and/or loads can fall unexpectedly and crush persons underneath. Never allow anyone to enter the area underneath raised equipment during operation.

Never operate engine in enclosed spaces as harmful exhaust gases may build up.

Before starting the machine, be sure that all controls are in neutral or park lock position.

Start the engine only from the operator's seat. If the safety start switch is bypassed, the engine can start with the transmission in gear. Do not connect or short across terminals on the starter solenoid. Attach jumper cables as described in the manual. Starting in gear may cause death or serious injury.

Always keep windows, mirrors, all lighting, and Slow Moving Vehicle (SMV) emblem clean to provide the best possible visibility while operating the machine.

Operate controls only when seated in the operator's seat, except for those controls expressly intended for use from other locations.

Before leaving the machine:

1. Park machine on a firm level surface.
2. Put all controls in neutral or park lock position.
3. Engage park brake. Use wheel chocks if required.
4. Lower all hydraulic equipment — Implements, header, etc.
5. Turn off engine and remove key.

When, due to exceptional circumstances, you would decide to keep the engine running after leaving the operator's station, then the following precautions must be followed:

1. Bring the engine to low idle speed.
2. Disengage all drive systems.

3. **⚠ WARNING**

**Some components may continue to run down after disengaging drive systems.  
Make sure all drive systems are fully disengaged.  
Failure to comply could result in death or serious injury.**

W0113A

Shift the transmission into neutral.

4. Apply the parking brake.

**⚠ General maintenance safety ⚠**

Keep area used for servicing the machine clean and dry. Clean up spilled fluids.

Service machine on a firm level surface.

Install guards and shields after servicing the machine.

Close all access doors and install all panels after servicing the machine.

Do not attempt to clean, lubricate, clear obstructions or make adjustments to the machine while it is in motion or while the engine is running.

Always make sure working area is clear of tools, parts, other persons and pets before you start operating the machine.

Unsupported hydraulic cylinders can lose pressure and drop the equipment causing a crushing hazard. Do not leave equipment in a raised position while parked or during service, unless securely supported.

Incorrect towing procedures can cause accidents. Contact your dealer if towing is required.

Stop the engine, remove key and relieve pressure before disconnecting or connecting fluid lines.

Stop the engine and remove key before disconnecting or connecting electrical connections.

Scalding can result from incorrect removal of coolant caps. Cooling system operates under pressure. Hot coolant can spray out if a cap is removed while the system is hot. Allow system to cool before removing cap. When removing a cap turn it slowly to allow pressure to escape before completely removing the cap.

Replace damaged or worn tubes, hoses, electrical wiring, etc.

Engine, transmission, exhaust components, and hydraulic lines may become hot during operation. Take care when servicing such components. Allow surfaces to cool before handling or disconnecting hot components. Wear protective equipment when appropriate.

When welding, remove all electrical monitors from unit to prevent damage. Always disconnect the battery before welding on the machine. Always wash your hands after handling battery components.

**⚠️ Wheels and tires ⚠️**

Make sure tires are correctly inflated. Do not exceed recommended load or pressure.

Tires are heavy. Handling tires without proper equipment could cause death or serious injury.

Always have a qualified tire technician service the tires and wheels. If a tire has lost all pressure, take the tire and wheel to a tire shop or your dealer for service. Explosive separation of the tire can cause serious injury.

DO NOT weld to a wheel or rim especially if a tire is installed. Inflated tires can generate a gas mixture with the air that can be ignited by high temperatures from welding procedures performed on the wheel or rim. Removing the air or loosening the tire on the rim (breaking the bead) will NOT eliminate the hazard. This condition can exist whether tires are inflated or deflated.

## **⚠ Driving on public roads and general transportation safety ⚠**

Comply with local laws and regulations.

Use appropriate lighting to meet local regulations.

Make sure SMV emblem is visible.

Lift implements and attachments high enough above ground to prevent accidental contact with road.

When transporting equipment or machine on a transport trailer, make sure it is properly secured. Be sure the SMV on the equipment or machine is covered while being transported on a trailer.

Be aware of overhead structures or power lines and make sure the machine and/or attachments can pass safely under.

Travel speed should be such that complete control and machine stability is maintained at all times.

Slow down and signal before turning.

Pull over to allow faster traffic to pass.

Follow correct towing procedure for equipment with or without brakes.

## **⚠ Fire and explosion prevention ⚠**

Fuel or oil leaked or spilled on hot surfaces or electrical components can cause a fire.

Crop materials, trash, debris, bird nests, or flammable material can ignite on hot surfaces.

Always have a fire extinguisher on or near the machine.

Make sure the fire extinguisher(s) is maintained and serviced according to the manufacturer's instructions.

At least once each day and at the end of the day remove all trash and debris from the machine especially around hot components such as engine, transmission, exhaust, battery, etc. More frequent cleaning of your machine may be necessary depending on the operating environment and conditions.

At least once each day, remove debris accumulation around moving components such as bearings, pulleys, belts, gears, cleaning fan, etc. More frequent cleaning of your machine may be necessary depending on the operating environment and conditions.

Inspect the electrical system for loose connections or frayed insulation. Repair or replace loose or damaged parts.

Do not store oily rags or other flammable material on the machine.

Do not weld or flame cut any items that contain flammable material. Clean items thoroughly with non-flammable solvents before welding or flame-cutting.

Do not expose the machine to flames, burning brush, or explosives.

Promptly investigate any unusual smells or odors that may occur during operation of the machine.

## **⚠ General battery safety ⚠**

Always wear eye protection when working with batteries.

Do not create sparks or have open flame near battery.

Ventilate when charging or using in an enclosed area.

Disconnect negative (-) first and reconnect negative (-) last.

When welding on the machine, disconnect both terminals of the battery.

## INTRODUCTION

---

Do not weld, grind, or smoke near a battery.

When using auxiliary batteries or connecting jumper cables to start the engine, use the procedure shown in the operator's manual. Do not short across terminals.

Follow manufacturer's instructions when storing and handling batteries.

Battery post, terminals, and related accessories contain lead and lead compounds. Wash hands after handling. This is a California Proposition 65 warning.

Battery acid causes burns. Batteries contain sulfuric acid. Avoid contact with skin, eyes, or clothing. Antidote (external): Flush with water. Antidote (eyes): flush with water for 15 minutes and seek medical attention immediately. Antidote (internal): Drink large quantities of water or milk. Do not induce vomiting. Seek medical attention immediately.

Keep out of reach of children and other unauthorized persons.

### **⚠ Instructional seat safety ⚠**

Passengers are not permitted to ride on the machine.

The instructional seat is to be used only when training a new operator or when a service technician is diagnosing a problem.

When required for the purposes of training or diagnostics, only one person may accompany the operator and that person must be seated in the instructional seat.

When the instructional seat is occupied, the following precautions must be followed:

- Machine should be driven only at slow speeds and over level ground.
- Avoid driving on highways or public roads.
- Avoid quick starts or stops.
- Avoid sharp turns.
- Always wear correctly adjusted seat belts.
- Keep door closed at all times.

### **⚠ Operator presence system ⚠**

Your machine is equipped with an operator presence system to prevent the use of some features while the operator is not in the operator's seat.

The operator presence system should never be disconnected or bypassed.

If the system is inoperable, the system must be repaired.

### **⚠ Reflectors and warning lights ⚠**

Flashing amber warning lights must be used when operating on public roads.

### **⚠ Seat belts ⚠**

Seat belts must be worn at all times.

Seat belt inspection and maintenance:

- Keep seat belts in good condition.
- Keep sharp edges and items that can cause damage away from the belts.
- Periodically check belts, buckles, retractors, tethers, slack take-up system, and mounting bolts for damage and wear.
- Replace all parts that have damage or wear.
- Replace belts that have cuts that can make the belt weak.
- Check that bolts are tight on the seat bracket or mounting.
- If belt is attached to seat, make sure seat or seat brackets are mounted securely.
- Keep seat belts clean and dry.
- Clean belts only with soap solution and warm water.
- Do not use bleach or dye on the belts because this can make the belts weak.

### **Air-conditioning system**

The air-conditioning system is under high pressure. Do not disconnect any lines. The release of high pressure can cause serious injury.

The air-conditioning system contains gases that are harmful to the environment when released into the atmosphere. Do not attempt to service or repair the system.

Service, repair, or recharging must be performed only by a trained service technician.

### **Personal Protective Equipment (PPE)**

Wear Personal Protective Equipment (PPE) such as hard hat, eye protection, heavy gloves, hearing protection, protective clothing, etc.

### **Do Not Operate tag**

Before you start servicing the machine, attach a 'Do Not Operate' warning tag to the machine in an area that will be visible.

### **Hazardous chemicals**

If you are exposed to or come in contact with hazardous chemicals you can be seriously injured. The fluids, lubricants, paints, adhesives, coolant, etc. required for the function of your machine can be hazardous. They may be attractive and harmful to domestic animals as well as humans.

Material Safety Data Sheets (MSDS) provide information about the chemical substances within a product, safe handling and storage procedures, first aid measures and procedures to be taken in the event of a spill or accidental release. MSDS are available from your dealer.

Before you service your machine check the MSDS for each lubricant, fluid, etc. used in this machine. This information indicates the associated risks and will help you service the machine safely. Follow the information in the MSDS, on manufacturer containers, as well as the information in this manual when servicing the machine.

Dispose of all fluids, filters, and containers in an environmentally safe manner according to local laws and regulations. Check with local environmental and recycling centers or your dealer for correct disposal information.

Store fluids and filters in accordance with local laws and regulations. Use only appropriate containers for the storage of chemicals or petrochemical substances.

Keep out of reach of children or other unauthorized persons.

Additional precautions are required for applied chemicals. Obtain complete information from the manufacturer or distributor of the chemicals before using them.

### **Utility safety**

Make sure the machine has sufficient clearance to pass in all directions. Pay special attention to overhead power lines and hanging obstacles. High voltage lines may require significant clearance for safety. Contact local authorities or utilities to obtain safe clearance distances from high voltage power lines.

Retract raised or extended components, if necessary. Remove or lower radio antennas or other accessories. Should a contact between the machine and an electric power source occur, the following precautions must be taken:

- Stop the machine movement immediately.
- Apply the park brake, stop the engine, and remove the key.
- Check if you can safely leave the cab or your actual position without contact with electrical wires. If not, stay in your position and call for help. If you can leave your position without touching lines, jump clear of the machine to make sure you do not make contact with the ground and the machine at the same time.
- Do not permit anyone to touch the machine until power has been shut off to the power lines.



## **Electrical storm safety**

Do not operate machine during an electrical storm.

If you are on the ground during an electrical storm, stay away from machinery and equipment. Seek shelter in a permanent, protected structure.

If an electrical storm should strike during operation, remain in the cab. Do not leave the cab or operator's platform. Do not make contact with the ground or objects outside the machine.

## **Mounting and dismounting**

Mount and dismount the machine only at designated locations that have handholds, steps, or ladders.

Do not jump off the machine.

Make sure steps, ladders, and platforms remain clean and clear of debris and foreign substances. Injury may result from slippery surfaces.

Face the machine when mounting and dismounting.

Maintain a three-point contact with steps, ladders, and handholds.

Never mount or dismount from a moving machine.

Do not use the steering wheel or other controls or accessories as handholds when entering or exiting the cab or operator's platform.

## **Working at heights**

When the normal use and maintenance of the machine requires working at heights:

- Correctly use installed steps, ladders, and railings.
- Never use ladders, steps, or railings while the machine is moving.
- Do not stand on surfaces which are not designated as steps or platforms.

Do not use the machine as a lift, ladder, or platform for working at heights.

## **Spraying**

- Be sure to clean and flush all residual chemicals from the sprayer before changing to another type of chemical. On some models, it may be necessary to remove the end caps from the spray bars to thoroughly flush the boom plumbing. In some cases a decontamination solution is recommended by the chemical manufacturer.
- Always follow chemical manufacturers safety instructions when mixing and applying herbicides and chemicals to prevent serious harm to people or the environment.
- Observe all Federal and State EPA regulations and all Local, State and Federal codes and/or laws regarding licensing, handling, storage, transportation, application and waste disposal of herbicides or other chemicals.
- Do not pump at pressures higher than the maximum recommended pressure.
- Secure the discharge lines before starting the pump. An insecure line may whip causing personal injury and/or property damage.
- Check hoses for wear or worn condition before each use. Make certain that all connections are tightly secured.
- Periodically inspect the product pump and the system components. Perform routine maintenance as required.
- Do not use these pumps for pumping water or other liquids for human or animal consumption.

## **Roll over and tip over**

- Travel speed should be such that complete control and machine stability is maintained at all times. Where possible, avoid operating near ditches, embankments and holes. Reduce speed when turning, crossing slopes, and on rough, slick, or muddy surfaces.
- Do not operate the unit on terrain outside its grade and stability limits. Operating the sprayer outside its limits may result in a roll over or tip over. Observe the guidelines in this manual when going down steep hills with load.
- Operating the unit on steep grades may result in a machine overturn. It is the operator's responsibility to make a judgment if weather, road or ground conditions permit safe operation on a hillside, ramp, ditch or rough ground.
- Use caution when operating the machine on slopes. Raised equipment, full tanks and other loads can change the center of gravity of the machine. The machine can tip or roll over when near ditches and embankments or uneven surfaces.
- Do not operate the unit near or on the soft shoulders of canals, brooks, other waterways or banks which are undermined by rodents. The unit may sink sideways and roll over.
- Do not operate the unit on poorly constructed or underrated ramps. The ramps may collapse and cause the sprayer to roll over. Always check the condition and rating of ramps before use.
- Do not operate the unit without using the seat restraint.
- Do not operate the unit beyond its limits of dynamic stability. High speed, abrupt maneuvers or fast and sharp cornering increase the risk of roll over.

---

## Safety rules - Ecology and the environment

Soil, air, and water quality is important for all industries and life in general. When legislation does not yet rule the treatment of some of the substances that advanced technology requires, sound judgment should govern the use and disposal of products of a chemical and petrochemical nature.

Familiarize yourself with the relative legislation applicable to your country, and make sure that you understand this legislation. Where no legislation exists, obtain information from suppliers of oils, filters, batteries, fuels, anti-freeze, cleaning agents, etc., with regard to the effect of these substances on man and nature and how to safely store, use, and dispose of these substances.

### Helpful hints

- Avoid the use of cans or other inappropriate pressurized fuel delivery systems to fill tanks. Such delivery systems may cause considerable spillage.
- In general, avoid skin contact with all fuels, oils, acids, solvents, etc. Most of these products contain substances that may be harmful to your health.
- Modern oils contain additives. Do not burn contaminated fuels and or waste oils in ordinary heating systems.
- Avoid spillage when you drain fluids such as used engine coolant mixtures, engine oil, hydraulic fluid, brake fluid, etc. Do not mix drained brake fluids or fuels with lubricants. Store all drained fluids safely until you can dispose of the fluids in a proper way that complies with all local legislation and available resources.
- Do not allow coolant mixtures to get into the soil. Collect and dispose of coolant mixtures properly.
- The air-conditioning system contains gases that should not be released into the atmosphere. Consult an air-conditioning specialist or use a special extractor to recharge the system properly.
- Repair any leaks or defects in the engine cooling system or hydraulic system immediately.
- Do not increase the pressure in a pressurized circuit as this may lead to a component failure.
- Protect hoses during welding. Penetrating weld splatter may burn a hole or weaken hoses, allowing the loss of oils, coolant, etc.

### Battery recycling

Batteries and electric accumulators contain several substances that can have a harmful effect on the environment if the batteries are not properly recycled after use. Improper disposal of batteries can contaminate the soil, groundwater, and waterways. NEW HOLLAND strongly recommends that you return all used batteries to a NEW HOLLAND dealer, who will dispose of the used batteries or recycle the used batteries properly. In some countries, this is a legal requirement.



### Mandatory battery recycling

**NOTE:** *The following requirements are mandatory in Brazil.*

Batteries are made of lead plates and a sulfuric acid solution. Because batteries contain heavy metals such as lead, CONAMA Resolution 401/2008 requires you to return all used batteries to the battery dealer when you replace any batteries. Do not dispose of batteries in your household garbage.

Points of sale are obliged to:

- Accept the return of your used batteries
- Store the returned batteries in a suitable location
- Send the returned batteries to the battery manufacturer for recycling

---

## Basic instructions - Shop and assembly

### Shimming

For each adjustment operation, select adjusting shims and measure the adjusting shims individually using a micrometer, then add up the recorded values. Do not rely on measuring the entire shimming set, which may be incorrect, or the rated value shown on each shim.

### Rotating shaft seals

For correct rotating shaft seal installation, proceed as follows:

1. Before assembly, allow the seal to soak in the oil it will be sealing for at least thirty minutes.
2. Thoroughly clean the shaft and check that the working surface on the shaft is not damaged.
3. Position the sealing lip facing the fluid.

**NOTE:** *With hydrodynamic lips, take into consideration the shaft rotation direction and position the grooves so that they will move the fluid towards the inner side of the seal.*

4. Coat the sealing lip with a thin layer of lubricant (use oil rather than grease). Fill the gap between the sealing lip and the dust lip on double lip seals with grease.
5. Insert the seal in its seat and press down using a flat punch or seal installation tool. Do not tap the seal with a hammer or mallet.
6. While you insert the seal, check that the seal is perpendicular to the seat. When the seal settles, make sure that the seal makes contact with the thrust element, if required.
7. To prevent damage to the seal lip on the shaft, position a protective guard during installation operations.

### O-ring seals

Lubricate the O-ring seals before you insert them in the seats. This will prevent the O-ring seals from overturning and twisting, which would jeopardize sealing efficiency.

### Sealing compounds

Apply a sealing compound on the mating surfaces when specified by the procedure. Before you apply the sealing compound, prepare the surfaces as directed by the product container.

### Spare parts

Only use CNH Original Parts or NEW HOLLAND Original Parts.

Only genuine spare parts guarantee the same quality, duration, and safety as original parts, as they are the same parts that are assembled during standard production. Only CNH Original Parts or NEW HOLLAND Original Parts can offer this guarantee.

When ordering spare parts, always provide the following information:

- Machine model (commercial name) and Product Identification Number (PIN)
- Part number of the ordered part, which can be found in the parts catalog

---

## Protecting the electronic and/or electrical systems during charging and welding

To avoid damage to the electronic and/or electrical systems, always observe the following practices:

1. Never make or break any of the charging circuit connections when the engine is running, including the battery connections.
2. Never short any of the charging components to ground.
3. Always disconnect the ground cable from the battery before arc welding on the machine or on any machine attachment.
  - Position the welder ground clamp as close to the welding area as possible.
  - If you weld in close proximity to a computer module, then you should remove the module from the machine.
  - Never allow welding cables to lie on, near, or across any electrical wiring or electronic component while you weld.
4. Always disconnect the negative cable from the battery when charging the battery in the machine with a battery charger.

**NOTICE:** *If you must weld on the unit, you must disconnect the battery ground cable from the machine battery. The electronic monitoring system and charging system will be damaged if this is not done.*

5. Remove the battery ground cable. Reconnect the cable when you complete welding.

### **⚠ WARNING**

**Battery acid causes burns. Batteries contain sulfuric acid.**

**Avoid contact with skin, eyes or clothing. Antidote (external): Flush with water. Antidote (eyes): flush with water for 15 minutes and seek medical attention immediately. Antidote (internal): Drink large quantities of water or milk. Do not induce vomiting. Seek medical attention immediately.**

**Failure to comply could result in death or serious injury.**

W0111A

## Special tools

The special tools that NEW HOLLAND suggests and illustrate in this manual have been specifically researched and designed for use with NEW HOLLAND machines. The special tools are essential for reliable repair operations. The special tools are accurately built and rigorously tested to offer efficient and long-lasting operation.

By using these tools, repair personnel will benefit from:

- Operating in optimal technical conditions
- Obtaining the best results
- Saving time and effort
- Working in safe conditions

## Torque - Minimum tightening torques for normal assembly

### Decimal hardware

#### Grade 5 bolts, nuts and studs

Size	Nm	lb in/lb ft
1/4 in	12 - 15 Nm	108 - 132 lb in
5/16 in	23 - 28 Nm	204 - 252 lb in
3/8 in	48 - 57 Nm	420 - 504 lb in
7/16 in	73 - 87 Nm	54 - 64 lb ft
1/2 in	109 - 130 Nm	80 - 96 lb ft
9/16 in	149 - 179 Nm	110 - 132 lb ft
5/8 in	203 - 244 Nm	150 - 180 lb ft
3/4 in	366 - 439 Nm	270 - 324 lb ft
7/8 in	542 - 651 Nm	400 - 480 lb ft
1 in	787 - 944 Nm	580 - 696 lb ft
1-1/8 in	1085 - 1193 Nm	800 - 880 lb ft
1-1/4 in	1519 - 1681 Nm	1120 - 1240 lb ft
1-3/8 in	1980 - 2278 Nm	1460 - 1680 lb ft
1-1/2 in	2631 - 2983 Nm	1940 - 2200 lb ft

#### Grade 8 bolts, nuts and studs

Size	Nm	lb in/lb ft
1/4 in	16 - 20 Nm	144 - 180 lb in
5/16 in	33 - 39 Nm	288 - 348 lb in
3/8 in	61 - 73 Nm	540 - 648 lb in
7/16 in	95 - 114 Nm	70 - 84 lb ft
1/2 in	149 - 179 Nm	110 - 132 lb ft
9/16 in	217 - 260 Nm	160 - 192 lb ft
5/8 in	298 - 358 Nm	220 - 264 lb ft
3/4 in	515 - 618 Nm	380 - 456 lb ft
7/8 in	814 - 976 Nm	600 - 720 lb ft
1 in	1220 - 1465 Nm	900 - 1080 lb ft
1-1/8 in	1736 - 1953 Nm	1280 - 1440 lb ft
1-1/4 in	2468 - 2712 Nm	1820 - 2000 lb ft
1-3/8 in	3227 - 3688 Nm	2380 - 2720 lb ft
1-1/2 in	4285 - 4827 Nm	3160 - 3560 lb ft

**NOTE:** Use thick nuts with Grade 8 bolts.

### Metric hardware

#### Grade 8.8 bolts, nuts and studs

Size	Nm	lb in/lb ft
4 mm	3 - 4 Nm	24 - 36 lb in
5 mm	7 - 8 Nm	60 - 72 lb in
6 mm	11 - 12 Nm	96 - 108 lb in
8 mm	26 - 31 Nm	228 - 276 lb in
10 mm	52 - 61 Nm	456 - 540 lb in
12 mm	90 - 107 Nm	66 - 79 lb ft
14 mm	144 - 172 Nm	106 - 127 lb ft
16 mm	217 - 271 Nm	160 - 200 lb ft
20 mm	434 - 515 Nm	320 - 380 lb ft
24 mm	675 - 815 Nm	500 - 600 lb ft
30 mm	1250 - 1500 Nm	920 - 1100 lb ft
36 mm	2175 - 2600 Nm	1600 - 1950 lb ft

INTRODUCTION

**Grade 10.9 bolts, nuts and studs**

Size	Nm	lb in/lb ft
4 mm	4 - 5 Nm	36 - 48 lb in
5 mm	9 - 11 Nm	84 - 96 lb in
6 mm	15 - 18 Nm	132 - 156 lb in
8 mm	37 - 43 Nm	324 - 384 lb in
10 mm	73 - 87 Nm	54 - 64 lb ft
12 mm	125 - 150 Nm	93 - 112 lb ft
14 mm	200 - 245 Nm	149 - 179 lb ft
16 mm	310 - 380 Nm	230 - 280 lb ft
20 mm	610 - 730 Nm	450 - 540 lb ft
24 mm	1050 - 1275 Nm	780 - 940 lb ft
30 mm	2000 - 2400 Nm	1470 - 1770 lb ft
36 mm	3500 - 4200 Nm	2580 - 3090 lb ft

**Grade 12.9 bolts, nuts and studs**

Size	Nm	lb in/lb ft
Typically the torque values specified for grade 10.9 hardware can be used satisfactorily on grade 12.9 hardware.		

**Steel hydraulic fittings**

**37° flare fitting**

Tube outside diameter/Hose inside diameter		Thread size	Nm	lb in/lb ft
mm	inch			
6.4 mm	1/4 in	7/16-20 in	8 - 16 Nm	72 - 144 lb in
7.9 mm	5/16 in	1/2-20 in	11 - 22 Nm	96 - 192 lb in
9.5 mm	3/8 in	9/16-18 in	14 - 34 Nm	120 - 300 lb in
12.7 mm	1/2 in	3/4-16 in	20 - 57 Nm	180 - 504 lb in
15.9 mm	5/6 in	7/8-14 in	34 - 79 Nm	300 - 696 lb in
19.0 mm	3/4 in	1-1/16-12 in	54 - 108 Nm	40 - 80 lb ft
22.2 mm	7/8 in	1-3/16-12 in	81 - 135 Nm	60 - 100 lb ft
25.4 mm	1 in	1-5/16-12 in	102 - 158 Nm	75 - 117 lb ft
31.8 mm	1-1/4 in	1-5/8-12 in	169 - 223 Nm	125 - 165 lb ft
38.1 mm	1-1/2 in	1-7/8-12 in	285 - 338 Nm	210 - 250 lb ft

**Straight threads with O-ring**

Tube outside diameter/Hose inside diameter		Thread size	Nm	lb in/lb ft
mm	inch			
6.4 mm	1/4 in	7/16-20 in	16 - 26 Nm	144 - 228 lb in
7.9 mm	5/16 in	1/2-20 in	22 - 34 Nm	192 - 300 lb in
9.5 mm	3/8 in	9/16-18 in	34 - 54 Nm	300 - 480 lb in
12.7 mm	1/2 in	3/4-16 in	57 - 91 Nm	540 - 804 lb in
15.9 mm	5/6 in	7/8-14 in	79 - 124 Nm	58 - 92 lb ft
19.0 mm	3/4 in	1-1/16-12 in	108 - 174 Nm	80 - 128 lb ft
22.2 mm	7/8 in	1-3/16-12 in	136 - 216 Nm	100 - 160 lb ft
25.4 mm	1 in	1-5/16-12 in	159 - 253 Nm	117 - 187 lb ft
31.8 mm	1-1/4 in	1-5/8-12 in	224 - 357 Nm	165 - 264 lb ft
38.1 mm	1-1/2 in	1-7/8-12 in	339 - 542 Nm	250 - 400 lb ft

**Split flange mounting bolts**

Size	Nm	lb in/lb ft
5/16-18 in	20 - 27 Nm	180 - 240 lb in
3/8-16 in	27 - 34 Nm	240 - 300 lb in
7/16-14 in	47 - 61 Nm	420 - 540 lb in
1/2-13 in	74 - 88 Nm	55 - 65 lb ft

INTRODUCTION

Size	Nm	lb in/lb ft
5/8-11 in	190 - 203 Nm	140 - 150 lb ft

Nominal SAE dash size	O-ring face seal end		Thread size	Nm	lb in/lb ft	O-ring boss end fitting or lock nut		
	Tube outside diameter mm	in				Thread size	Nm	lb in/lb ft
-4	6.4 mm	1/4 in	9/16-18 in	14 - 16 Nm	120 - 144 lb in	7/16-20 in	23 - 27 Nm	204 - 240 lb in
-6	9.5 mm	3/8 in	11/16-16 in	24 - 27 Nm	216 - 240 lb in	9/16-18 in	34 - 41 Nm	300 - 360 lb in
-8	12.7 mm	1/2 in	13/16-16 in	43 - 54 Nm	384 - 480 lb in	3/4-16 in	61 - 68 Nm	540 - 600 lb in
-10	15.9 mm	5/8 in	1-14 in	62 - 76 Nm	552 - 672 lb in	7/8-14 in	81 - 88 Nm	60 - 65 lb ft
-12	19.0 mm	3/4 in	1-3/16-12 in	90 - 110 Nm	65 - 80 lb ft	1-1/16-12 in	115 - 122 Nm	85 - 90 lb ft
-14	22.2 mm	7/8 in	1-3/16-12 in	90 - 110 Nm	65 - 80 lb ft	1-13/16-12 in	129 - 136 Nm	95 - 100 lb ft
-16	25.41 mm	1.0 in	1-7/16-12 in	125 - 140 Nm	92 - 105 lb ft	1-5/16-12 in	156 - 169 Nm	115 - 125 lb ft
-20	31.8 mm	1-1/4 in	1-11/16-12 in	170 - 190 Nm	125 - 140 lb ft	1-5/8-12 in	201 - 217 Nm	150 - 160 lb ft
-24	38.1 mm	1-1/2 in	2-12 in	200 - 254 Nm	150 - 180 lb ft	1-7/8-12 in	258 - 271 Nm	190 - 200 lb ft



## Torque - Standard torque data for hydraulics

### Installation of adjustable fittings in straight thread O-ring bosses

1. Lubricate the O-ring by coating it with a light oil or petroleum. Install the O-ring in the groove adjacent to the metal backup washer which is assembled at the extreme end of the groove (4).
2. Install the fitting into the SAE straight thread boss until the metal backup washer contacts the face of the boss (5).

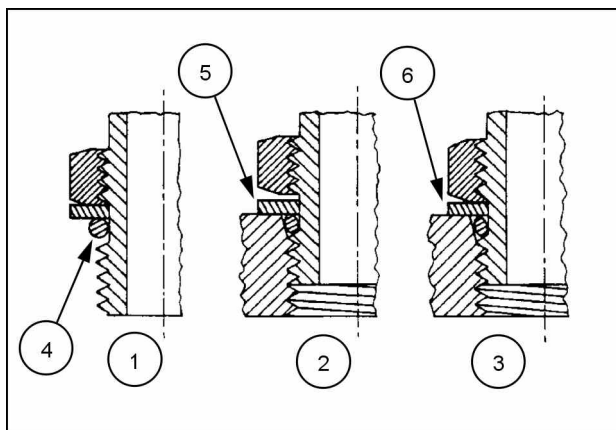

23085659 1

**NOTE:** Do not over tighten and distort the metal backup washer.

3. Position the fitting by turning out (counterclockwise) up to a maximum of one turn. Holding the pad of the fitting with a wrench, tighten the locknut and washer against the face of the boss (6).

### Standard torque data for hydraulic tubes and fittings

Tube nuts for 37° flared fittings				O-ring boss plugs adjustable fitting locknuts, swivel JIC-37° seats
Size	Tubing OD	Thread size	Torque	Torque
4	6.4 mm (1/4 in)	7/16-20	12 - 16 N·m (9 - 12 lb ft)	8 - 14 N·m (6 - 10 lb ft)
5	7.9 mm (5/16 in)	1/2-20	16 - 20 N·m (12 - 15 lb ft)	14 - 20 N·m (10 - 15 lb ft)
6	9.5 mm (3/8 in)	9/16-18	29 - 33 N·m (21 - 24 lb ft)	20 - 27 N·m (15 - 20 lb ft)
8	12.7 mm (1/2 in)	3/4-16	47 - 54 N·m (35 - 40 lb ft)	34 - 41 N·m (25 - 30 lb ft)
10	15.9 mm (5/8 in)	7/8-14	72 - 79 N·m (53 - 58 lb ft)	47 - 54 N·m (35 - 40 lb ft)
12	19.1 mm (3/4 in)	1-1/16-12	104 - 111 N·m (77 - 82 lb ft)	81 - 95 N·m (60 - 70 lb ft)
14	22.2 mm (7/8 in)	1-3/16-12	122 - 136 N·m (90 - 100 lb ft)	95 - 109 N·m (70 - 80 lb ft)
16	25.4 mm (1 in)	1-5/16-12	149 - 163 N·m (110 - 120 lb ft)	108 - 122 N·m (80 - 90 lb ft)
20	31.8 mm (1-1/4 in)	1-5/8-12	190 - 204 N·m (140 - 150 lb ft)	129 - 158 N·m (95 - 115 lb ft)
24	38.1 mm (1-1/2 in)	1-7/8-12	217 - 237 N·m (160 - 175 lb ft)	163 - 190 N·m (120 - 140 lb ft)
32	50.8 mm (2 in)	2-1/2-12	305 - 325 N·m (225 - 240 lb ft)	339 - 407 N·m (250 - 300 lb ft)

These torques are not recommended for tubes of 12.7 mm (1/2 in) OD and larger with wall thickness of 0.889 mm (0.035 in) or less. The torque is specified for 0.889 mm (0.035 in) wall tubes on each application individually.

Before installing and torquing 37° flared fittings, clean the face of the flare and threads with a clean solvent or Loctite cleaner and apply hydraulic sealant **LOCTITE® 569™** to the 37° flare and the threads.

Install fitting and torque to specified torque, loosen fitting and retorque to specifications.

**Pipe thread fitting torque**

Before installing and tightening pipe fittings, clean the threads with a clean solvent or Loctite cleaner and apply sealant **LOCTITE® 567™ PST PIPE SEALANT** for all fittings including stainless steel or **LOCTITE® 565™ PST** for most metal fittings. For high filtration/zero contamination systems use **LOCTITE® 545™**.

Thread size	Torque (maximum)
1/8-27	<b>13 N·m (10 lb ft)</b>
1/4-18	<b>16 N·m (12 lb ft)</b>
3/8-18	<b>22 N·m (16 lb ft)</b>
1/2-14	<b>41 N·m (30 lb ft)</b>
3/4-14	<b>54 N·m (40 lb ft)</b>

**Installation of ORFS (O-Ring Flat Seal fittings)**

When installing ORFS fittings thoroughly clean both flat surfaces of the fittings **(1)** and lubricate the O-ring **(2)** with light oil. Make sure both surfaces are aligned properly. Torque the fitting to specified torque listed throughout the repair manual.

**NOTICE:** *If the fitting surfaces are not properly cleaned, the O-ring will not seal properly. If the fitting surfaces are not properly aligned, the fittings may be damaged and will not seal properly.*

**NOTICE:** *Always use genuine factory replacement oils and filters to ensure proper lubrication and filtration of engine and hydraulic system oils.*

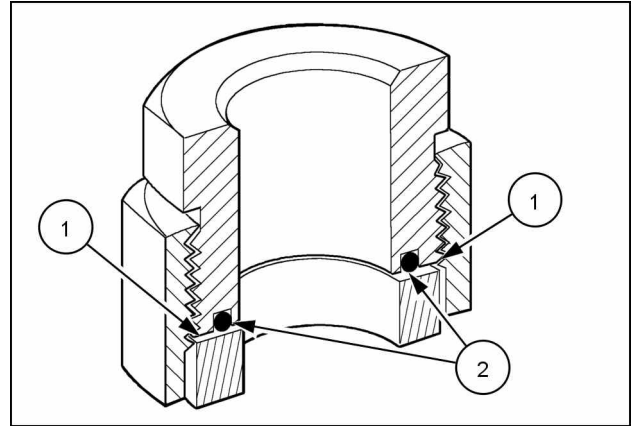

50011183 2

The use of proper oils, grease, and keeping the hydraulic system clean will extend machine and component life.

# Maintenance chart

Maintenance action	Tighten				Lubricate				Page no.
	Cleaning				Replace				
	Grease				Change fluid				
	Check				Adjust				
	Drain fluid				Test				
At warning message display									
Fuel filter									
Engine coolant level									
First 10 hours									
Tire lug nuts									
Every 10 hours or daily									
Engine air filter (Note 1)									
Engine oil level									
Engine coolant level									
Hydraulic oil level									
Air tank									
Boom									
Strainers									
King pins									
Fuel filter									
Suspension system									
Steering cylinder balljoints									
Trash and debris									
Hydraulic components									
Every 50 hours									
Tire lug nuts									
Foam heads and in-line filter									
Suspension valve linkage pivots									
Leg widening axle slide pads									
Cooling package									
Every 100 hours									
Tire inflation									
Every 250 hours									
Engine air filter									
Air compressor									
Charge air cooler									
Radiator hoses									
Hydro filters									
Walkway railing lock									
Brake circuit filter									
Every 400 hours									
Secondary fuel filter									
Hydraulic oil filters									
Hydraulic reservoir breather									
Every 500 hours									
Engine oil and filter									
Primary fuel filter									
Coolant PH level									
Once a year									
Cab charcoal pressurization filter (Note 2)									
Cab recirculation filter									
Every 750 hours									
Engine air intake system									

INTRODUCTION

Maintenance action	Tighten					Lubricate					Page no.	
	Cleaning					Replace						
	Grease					Change fluid						
	Check					Adjust						
	Drain fluid					Test						
Engine speeds												
Every 1000 hours												
Hydraulic oil												
Belt tensioner												
Every two years												
Engine coolant												
Cooling system thermostats												
Every 1500 hours												
Fuel injector nozzles												
Engine breather filter												
Every 4500 hours												
Diesel Exhaust Fluid (DEF)/AdBlue® supply module filter												
Every 5000 hours												
Engine valve clearance												
Engine brake assembly												
As required												
Cooling package												
Flow meter												
Flow meter cable												
Chassis suspension												
Boom breakaway tension												
Steering toe in												
Boom cylinder speed												

## Hydraulic contamination

Contamination in the hydraulic system is a major cause of the malfunction of hydraulic components. Contamination is any foreign material in the hydraulic oil.

Contamination can enter the hydraulic system in several ways:

- When you drain the oil or disconnect any line
- When you disassemble a component
- From normal wear of the hydraulic components
- From damaged seals or worn seals
- From a damaged component in the hydraulic system

All hydraulic systems operate with some contamination. The design of the components in this hydraulic system permits efficient operation with a small amount of contamination. An increase in this amount of contamination can cause problems in the hydraulic system.

The following list includes some of these problems:

- Cylinder rod seals that leak
- Control valve spools that do not return to neutral
- Movement of control valve spools is difficult
- Hydraulic oil that becomes too hot
- Pump gears, housing, and other parts that wear rapidly
- Relief valves or check valves held open by dirt
- Quick failure of components that have been repaired
- Slow cycle times are slow. The machine does not have enough power.

If your machine has any of these problems, check the hydraulic oil for contamination.

There are two types of contamination: microscopic and visible.

Microscopic contamination occurs when very fine particles of foreign material are suspended in the hydraulic oil. These particles are too small to see or feel. Microscopic contamination can be found by identification of the following problems or by testing in a laboratory.

Examples of problems caused by microscopic contamination:

- Cylinder rod seals that leak
- Control valve spools that do not return to neutral
- The hydraulic system has a high operating temperature

Visible contamination is foreign material that can be found by sight, touch, or odor. Visible contamination can cause a sudden failure of components.

Examples of problems caused by visible contamination:

- Particles of metal or dirt in the oil
- Air in the oil
- Dark or thick oil
- Oil with an odor of burned oil
- Water in the oil

If you find contamination, use a portable filter to clean the hydraulic system.

## Capacities

<b>Engine</b>	
Oil type	<b>NEW HOLLAND AMBRA UNITEK MASTERGOLD SBL CJ-4</b>
Capacity	Refer to your Cummins manual
<b>Cooling system</b>	
Coolant type	<b>NEW HOLLAND AMBRA AGRIFLU</b> 50-50 water and ethylene glycol mix
Coolant capacity	Approximately <b>38 l (10 US gal)</b> (does not include the heater core or cab plumbing).
<b>Hydraulic system</b>	
Oil type	<b>NEW HOLLAND AMBRA HYDROSYSTEM 68</b>
Tank capacity	Approximately <b>132 l (35 US gal)</b>
<b>Air conditioning system</b>	
Refrigerant type	<b>CNH REFRIGERANT HFC-134A</b>

## General specification

<b>Model SP.295F</b>	
Engine	Cummins QSB Tier 4 Final <b>300 Hp</b> — power bulge to <b>310 Hp</b>
Fuel capacity and type	<b>568 l (150 US gal)</b> Ultra low sulfur diesel
Diesel Exhaust Fluid (DEF) Capacity	<b>56.8 L (15.0 US gal)</b>
Cooling package	Stacked side by side single pass design, hydraulically driven fan
Engine/transmission	Located in rear - ISO mounted
Transmission	Torq-Trac® hydrostatic drive system with Twin Sauer-Danfoss heavy duty pumps
Hydro pump displacement	75 cc each
Final drives	Poclair® - MW 14 (front) and Poclair® - MS 18 (rear)
Parking brake	4 wheel
Service brake	4 wheel internal wet disc
Steering	
Standard front wheel	Hydrostatic with two steering cylinders, no tie rods, <b>4.1 m (13.5 ft)</b> turning radius
Optional 4 wheel steer	<b>4.1 m (13.5 ft)</b> turn radius in 4 wheel steer, <b>5.3 m (17.5 ft)</b> turn radius in 2 wheel steer
HYDRALINK™ Suspension	Full suspension travel of <b>51 cm (20 in)</b> . 4-wheel independent with integrated hydraulic leveling/shock absorbers, auto leveling for each wheel leg.
Crop clearance	<b>183 cm (72 in)</b>
Wheel width adjustment	<b>305 - 406 cm (120 - 160 in)</b> , hydraulic adjust, wheels move in/out equally on both sides. Operator remains centered.
Air system	Direct engine driven, water cooled air compressor and air storage tank.
Auxiliary hydraulic circuit	<b>117 l/min (31 US gpm)</b> - Optional <b>193 l/min (51 US gpm)</b> closed center
Product tank options	
Poly or Stainless steel	<b>3785 L (1000 US gal)</b>
Poly or Stainless steel	<b>4542 L (1200 US gal)</b>
Product pump standard	
Product pump standard	Hypro 9306C - <b>795 l/min @ 5.5 bar ( 210 US gpm @ 80 psi)</b>
Product pump optional	Hypro 9307C high capacity - <b>1173 l/min @ 5.5 bar ( 310 US gpm @ 80 psi)</b>
Rinse tank standard	<b>568 l (150 US gal)</b> , Poly
Boom options	<b>60 ft, 75 ft/60 ft, 80 ft/60 ft, 90 ft/60 ft, 100 ft/60 ft, 120 ft/ 70 ft, 27 m/ 18 m, 30 m/ 18 m, 32 m/ 18 m, 36 m/ 22 m</b>
Boom lines	Standard <b>2.54 cm (1 in)</b> stainless steel — Optional <b>3.81 cm (1.5 in)</b> stainless steel
Cab	SprayView Cab or Premium SprayView Cab
Height	<b>401 cm (158 in)</b>
Width (transport)	<b>368 cm (145 in)</b>
Length (boom unfolded)	<b>859 cm (338 in)</b>
Wheel base	<b>389 cm (153 in)</b>
Boom travel	Lowered <b>56 cm (22 in)</b> — Raised <b>300 cm (118 in)</b>
Weight (approximate)	<b>12927 kg (28500 lb)</b>

INTRODUCTION

<b>Model SP.300F</b>	
Engine	Cummins QSB Tier 4 Final <b>300 Hp</b> — power bulge to <b>310 Hp</b>
Fuel capacity and type	<b>568 l (150 US gal)</b> Ultra low sulfur diesel
Diesel Exhaust Fluid (DEF) Capacity	<b>56.8 L (15.0 US gal)</b>
Cooling package	Stacked side by side single pass design, hydraulically driven fan
Engine/transmission	Located in rear - ISO mounted
Transmission	Torq-Trac® hydrostatic drive system with Twin Sauer-Danfoss heavy duty pumps
Hydro pump displacement	100 cc each
Final drives	Poclain® - MS 18 (front and rear)
Parking brake	4 wheel
Service brake	4 wheel internal wet disc
Steering	
Standard front wheel	Hydrostatic with two steering cylinders, no tie rods, <b>4.6 m (15.0 ft)</b> turning radius
Optional 4 wheel steer	<b>4.6 m (15.0 ft)</b> turn radius in 4 wheel steer, <b>6.4 m (21.0 ft)</b> turn radius in 2 wheel steer
HYDRALINK™ Suspension	Full suspension travel of <b>51 cm (20 in)</b> . 4-wheel independent with integrated hydraulic leveling/shock absorbers, auto leveling for each wheel leg.
Crop clearance	<b>183 cm (72 in)</b>
Wheel width adjustment	<b>305 - 406 cm (120 - 160 in)</b> , hydraulic adjust, wheels move in/out equally on both sides. Operator remains centered.
Air system	Direct engine driven, water cooled air compressor and air storage tank.
Auxiliary hydraulic circuit	<b>117 l/min (31 US gpm)</b> - Optional <b>193 l/min (51 US gpm)</b> closed center
Product tank options	
Stainless steel	<b>4542 L (1200 US gal)</b>
Stainless steel	<b>5300 L (1400 US gal)</b>
Stainless steel	<b>6057 L (1600 US gal)</b>
Product pump standard	Hypro 9306C - <b>795 l/min @ 5.5 bar ( 210 US gpm @ 80 psi)</b>
Product pump optional	Hypro 9307C high capacity - <b>1173 l/min @ 5.5 bar ( 310 US gpm @ 80 psi)</b>
Rinse tank standard	<b>568 l (150 US gal)</b> , Poly
Boom options	<b>60 ft, 75 ft/60 ft, 80 ft/60 ft, 90 ft/60 ft, 100 ft/60 ft, 120 ft/ 70 ft, 27 m/ 18 m, 30 m/ 18 m, 32 m/ 18 m, 36 m/ 22 m</b>
Boom lines	Standard <b>2.54 cm (1 in)</b> stainless steel — Optional <b>3.81 cm (1.5 in)</b> stainless steel
Cab	SprayView Cab or Premium SprayView Cab
Height	<b>401 cm (158 in)</b>
Width (transport)	<b>368 cm (145 in)</b>
Length (boom unfolded)	<b>922 cm (363 in)</b>
Wheel base	<b>450 cm (177 in)</b>
Boom travel	Lowered <b>56 cm (22 in)</b> — Raised <b>300 cm (118 in)</b>
Weight (approximate)	<b>14016 kg (30900 lb)</b>



INTRODUCTION

<b>Model SP.345F</b>	
Engine	Cummins QSL Tier 4 Final <b>320 Hp</b> — power bulge to <b>345 Hp</b>
Fuel capacity and type	<b>568 l (150 US gal)</b> Ultra low sulfur diesel
Diesel Exhaust Fluid (DEF) Capacity	<b>56.8 L (15.0 US gal)</b>
Cooling package	Stacked side by side single pass design, hydraulically driven fan
Engine/transmission	Located in rear - ISO mounted
Transmission	Torq-Trac® hydrostatic drive system with Twin Sauer-Danfoss heavy duty pumps
Hydro pump displacement	130 cc each
Final drives	Poclain® - MS 18
Parking brake	4 wheel
Service brake	4 wheel internal wet disc
Steering	
Standard front wheel	Hydrostatic with two steering cylinders, no tie rods, <b>4.6 m (15.0 ft)</b> turning radius
Optional 4 wheel steer	<b>4.6 m (15.0 ft)</b> turn radius in 4 wheel steer, <b>6.4 m (21.0 ft)</b> turn radius in 2 wheel steer
HYDRALINK™ Suspension	Full suspension travel of <b>51 cm (20 in)</b> . 4-wheel independent with integrated hydraulic leveling/shock absorbers, auto leveling for each wheel leg.
Crop clearance	<b>183 cm (72 in)</b>
Wheel width adjustment	<b>305 - 406 cm (120 - 160 in)</b> , hydraulic adjust, wheels move in/out equally on both sides. Operator remains centered.
Air system	Direct engine driven, water cooled air compressor and air storage tank.
Auxiliary hydraulic circuit	<b>98.4 L/min (26.0 US gpm)</b> - Optional <b>166.6 L/min (44.0 US gpm)</b> closed center
Product tank options	
Stainless steel	<b>4542 L (1200 US gal)</b>
Stainless steel	<b>5300 L (1400 US gal)</b>
Stainless steel	<b>6057 L (1600 US gal)</b>
Product pump standard	
Product pump standard	Hypro 9306C - <b>795 l/min @ 5.5 bar ( 210 US gpm @ 80 psi)</b>
Product pump optional	Hypro 9307C high capacity - <b>1173 l/min @ 5.5 bar ( 310 US gpm @ 80 psi)</b>
Rinse tank standard	<b>568 l (150 US gal)</b> , Poly
Boom options	<b>80 ft/ 60 ft, 90 ft/ 60 ft, 100 ft/ 60 ft, 120 ft/ 70 ft, 27 m/ 18 m, 30 m/ 18 m, 32 m/ 18 m, 36 m/ 22 m</b>
Boom lines	Standard <b>2.54 cm (1 in)</b> stainless steel — Optional <b>3.81 cm (1.5 in)</b> stainless steel
Cab	SprayView Cab or Premium SprayView Cab
Height	<b>401 cm (158 in)</b>
Width (transport)	<b>368 cm (145 in)</b>
Length (boom unfolded)	<b>922 cm (363 in)</b>
Wheel base	<b>450 cm (177 in)</b>
Boom travel	Lowered <b>56 cm (22 in)</b> — Raised <b>300 cm (118 in)</b>
Weight (approximate)	<b>14969 kg (33000 lb)</b>

INTRODUCTION

<b>Model SP.400F</b>	
Engine	Cummins QSL Tier 4 Final <b>380 Hp</b> — power bulge to <b>400 Hp</b>
Fuel capacity and type	<b>568 l (150 US gal)</b> Ultra low sulfur diesel
Diesel Exhaust Fluid (DEF) Capacity	<b>56.8 L (15.0 US gal)</b>
Cooling package	Stacked side by side single pass design, hydraulically driven fan
Engine/transmission	Located in rear - ISO mounted
Transmission	Torq-Trac® hydrostatic drive system with Twin Sauer-Danfoss heavy duty pumps
Hydro pump displacement	130 cc each
Final drives	Poclain® - MW 24
Parking brake	4 wheel
Service brake	4 wheel internal wet disc
Steering	
Standard front wheel	Hydrostatic with two steering cylinders, no tie rods, <b>4.6 m (15.0 ft)</b> turning radius
Optional 4 wheel steer	<b>4.6 m (15.0 ft)</b> turn radius in 4 wheel steer, <b>6.4 m (21.0 ft)</b> turn radius in 2 wheel steer
HYDRALINK™ Suspension	Full suspension travel of <b>51 cm (20 in)</b> . 4-wheel independent with integrated hydraulic leveling/shock absorbers, auto leveling for each wheel leg.
Crop clearance	<b>183 cm (72 in)</b>
Wheel width adjustment	<b>305 - 406 cm (120 - 160 in)</b> , hydraulic adjust, wheels move in/out equally on both sides. Operator remains centered.
Air system	Direct engine driven, water cooled air compressor and air storage tank.
Auxiliary hydraulic circuit	<b>98.4 L/min (26.0 US gpm)</b> - Optional <b>166.6 L/min (44.0 US gpm)</b> closed center
Product tank options	
Stainless steel	<b>4542 L (1200 US gal)</b>
Stainless steel	<b>5300 L (1400 US gal)</b>
Stainless steel	<b>6057 L (1600 US gal)</b>
Product pump standard	Hypro 9306C - <b>795 l/min @ 5.5 bar ( 210 US gpm @ 80 psi)</b>
Product pump optional	Hypro 9307C high capacity - <b>1173 l/min @ 5.5 bar ( 310 US gpm @ 80 psi)</b>
Rinse tank standard	<b>568 l (150 US gal)</b> , Poly
Boom options	<b>80 ft/ 60 ft, 90 ft/ 60 ft, 100 ft/ 60 ft, 120 ft/ 70 ft, 27 m/ 18 m, 30 m/ 18 m, 32 m/ 18 m, 36 m/ 22 m</b>
Boom lines	Standard <b>2.54 cm (1 in)</b> stainless steel — Optional <b>3.81 cm (1.5 in)</b> stainless steel
Cab	SprayView Cab or Premium SprayView Cab
Height	<b>401 cm (158 in)</b>
Width (transport)	<b>368 cm (145 in)</b>
Length (boom unfolded)	<b>922 cm (363 in)</b>
Wheel base	<b>450 cm (177 in)</b>
Boom travel	Lowered <b>56 cm (22 in)</b> — Raised <b>300 cm (118 in)</b>
Weight (approximate)	<b>15386 kg (33920 lb)</b>

---

## Product identification - Sprayer model and serial number

The machine serial number is located on the front side frame cross tube below the cab and above the fill snorkel latch bar. The machine serial number can also be displayed on the chassis monitor.

**NOTE:** Located on front frame just below cab.

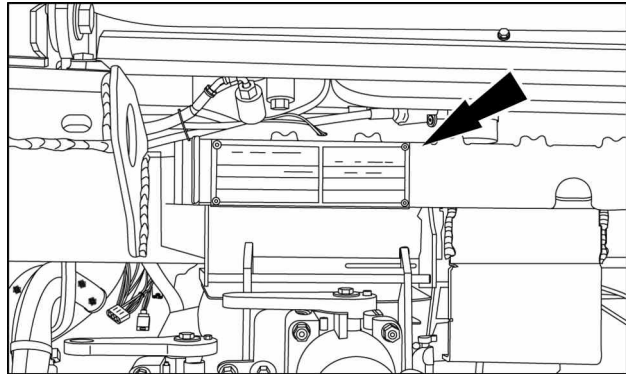

RAIL12SP01219AA 1

## Product identification - Machine orientation

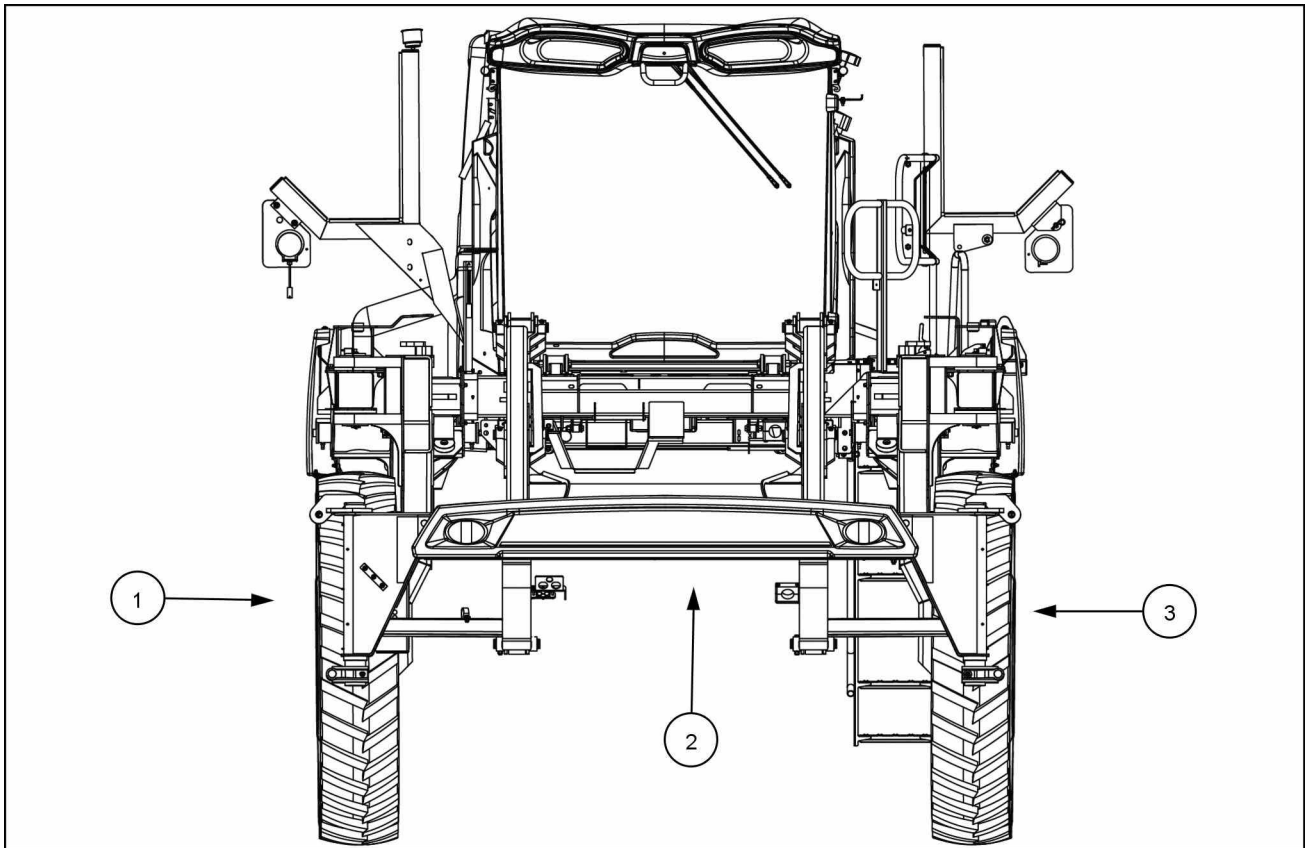

RAIL14SP00996FA 1

1. Right hand side	2. Front of unit	3. Left hand side
--------------------	------------------	-------------------

# INTRODUCTION

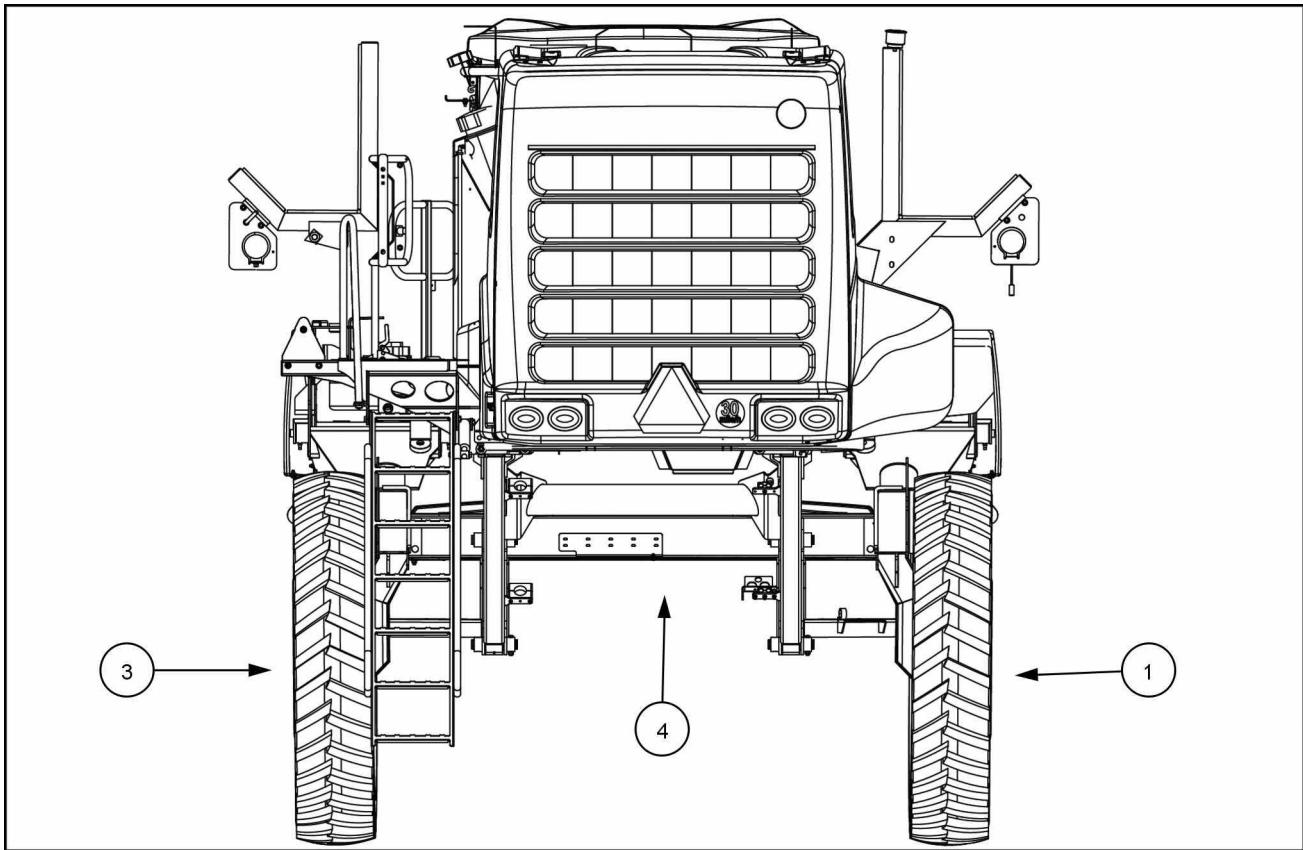

RAIL14SP00997FA 2

1. Right hand side

3. Left hand side

4. Rear of unit



# **SERVICE MANUAL**

## **Engine**

**SP.295F**

**SP.300F**

**SP.345F**

**SP.400F**

# Contents

---

## Engine - 10

[10.001] Engine and crankcase .....	10.1
[10.114] Pump drives .....	10.2
[10.216] Fuel tanks .....	10.3
[10.206] Fuel filters .....	10.4
[10.202] Air cleaners and lines .....	10.5
[10.500] Selective Catalytic Reduction (SCR) exhaust treatment.....	10.6
[10.400] Engine cooling system .....	10.7
[10.414] Fan and drive .....	10.8



## **Engine - 10**

### **Engine and crankcase - 001**

**SP.295F  
SP.300F  
SP.345F  
SP.400F**



This as a preview PDF file from [best-manuals.com](http://best-manuals.com)



Download full PDF manual at [best-manuals.com](http://best-manuals.com)