

The CASE logo is displayed in white, bold, italicized capital letters. It is positioned on a black trapezoidal background that tapers to the right. A horizontal orange bar is located directly beneath the letters.

REPAIR MANUAL
SKID STEER/ COMPACT TRACK LOADER

435
445
445CT
SERIES 3

87634768 NA

Issued 01Jan08



REPAIR MANUAL



435
445CT
445

Contents

INTRODUCTION

DISTRIBUTION SYSTEMS A

PRIMARY HYDRAULIC POWER SYSTEM	A.10.A
SECONDARY HYDRAULIC POWER SYSTEM	A.12.A
HIGH-FLOW HYDRAULIC POWER SYSTEM	A.16.A
ELECTRICAL POWER SYSTEM	A.30.A
LIGHTING SYSTEM	A.40.A
HYDRAULIC COMMAND SYSTEM	A.14.A

POWER PRODUCTION B

ENGINE	B.10.A
FUEL AND INJECTION SYSTEM	B.20.A
AIR INTAKE SYSTEM	B.30.A
ENGINE COOLANT SYSTEM	B.50.A
LUBRICATION SYSTEM	B.60.A
STARTING SYSTEM	B.80.A

POWER TRAIN C

POWER COUPLING Fixed coupling	C.10.B
TRANSMISSION Hydrostatic	C.20.F

TRAVELLING D

FRONT AXLE	D.10.A
REAR AXLE	D.12.A
PARKING BRAKE Hydraulic	D.32.C
WHEELS AND TRACKS Tracks	D.50.B
WHEELS AND TRACKS Wheels	D.50.C
Final drive	D.15.A
STEERING Mechanical	D.20.B

BODY AND STRUCTURE E

USER CONTROLS AND SEAT	E.32.A
USER PLATFORM	E.34.A

ENVIRONMENT CONTROL Heating system	E.40.B
ENVIRONMENT CONTROL Air-conditioning system	E.40.C
SAFETY SECURITY ACCESSORIES Safety	E.50.B
WORKING ARM	H
SINGLE ARM Lift	H.40.B
SINGLE ARM TOOL ATTACHMENT Tilt	H.50.C
TOOLS AND COUPLERS	J
CARRYING Unarticulated tools	J.50.B
COUPLING Hydraulic coupling	J.80.C
COUPLING Mechanical coupling	J.80.B



INTRODUCTION

Contents

INTRODUCTION

Basic instructions	3
Torque	7
Consumables	11
Conversion factors	15

Basic instructions

Technical Information

This manual has been produced by a new technical information system. This new system is designed to deliver technical information electronically through CDROM and in paper manuals. A coding system called ICE has been developed to link the technical information to other Product Support functions e.g. Warranty.

Technical information is written to support the maintenance and service of the functions or systems on a customer's machine. When a customer has a concern on his machine it is usually because a function or system on his machine is not working at all, is not working efficiently, or is not responding correctly to his commands. When you refer to the technical information in this manual to resolve that customer's concern, you will find all the information classified using the new ICE coding, according to the functions or systems on that machine. Once you have located the technical information for that function or system then you will find all the mechanical, electrical or hydraulic devices, components, assemblies and sub-assemblies for that function or system. You will also find all the types of information that have been written for that function or system, the technical data (specifications), the functional data (how it works), the diagnostic data (fault codes and troubleshooting) and the service data (remove, install adjust, etc.).

By integrating this new ICE coding into technical information, you will be able to search and retrieve just the right piece of technical information you need to resolve that customer's concern on his machine. This is made possible by attaching 3 categories to each piece of technical information during the authoring process.

The first category is the Location, the second category is the Information Type and the third category is the Product:

- LOCATION - is the component or function on the machine, that the piece of technical information is going to describe e.g. Fuel tank.
- INFORMATION TYPE - is the piece of technical information that has been written for a particular component or function on the machine e.g. Capacity would be a type of Technical Data that would describe the amount of fuel held by the Fuel tank.
- PRODUCT - is the model that the piece of technical information is written for.

Every piece of technical information will have those 3 categories attached to it. You will be able to use any combination of those categories to find the right piece of technical information you need to resolve that customer's concern on his machine.

That information could be:

- the description of how to remove the cylinder head
- a table of specifications for a hydraulic pump
- a fault code
- a troubleshooting table
- a special tool

How to Use this Manual

This manual is divided into Sections. Each Section is then divided into Chapters. Contents pages are included at the beginning of the manual, then inside every Section and inside every Chapter. An alphabetical Index is included at the end of a Chapter. Page number references are included for every piece of technical information listed in the Chapter Contents or Chapter Index.

Each Chapter is divided into four Information types:

- **(D)** Technical Data (specifications) for all the mechanical, electrical or hydraulic devices, components and assemblies.
- **(C)** Functional Data (how it works) for all the mechanical, electrical or hydraulic devices, components and assemblies.
- **(G)** Diagnostic Data (fault codes, electrical and hydraulic troubleshooting) for all the mechanical, electrical or hydraulic devices, components and assemblies.

INTRODUCTION

- **(F)** Service data (remove disassembly, assemble, install) for all the mechanical, electrical or hydraulic devices, components and assemblies.

Sections

Sections are grouped according to the main functions or a systems on the machine. Each Section is identified by a letter A, B, C etc. The amount of Sections included in the manual will depend on the type and function of the machine that the manual is written for. Each Section has a Contents page listed in alphabetic/numeric order. This table illustrates which Sections could be included in a manual for a particular product.

PRODUCT	SECTION										
	A - Distribution Systems										
	B - Power Production										
	C - Power Train										
	D - Travelling										
	E - Body and Structure										
	F - Frame Positioning										
	G - Tool Positioning										
	H - Working Arm										
	J - Tools and Couplers										
	K - Crop Processing										
L - Field Processing											
Tractors	X	X	X	X	X	X		X	X		
Vehicles with working arms: backhoes, excavators, skid steers,	X	X	X	X	X	X	X	X	X		
Combines, forage harvesters, balers,	X	X	X	X	X	X	X	X	X	X	
Seeding, planting, floating, spraying equipment,	X	X	X	X	X	X	X		X		X
Mounted equipment and tools,					X	X	X		X		

Chapters

Each Chapter is identified by a letter and number combination e.g. Engine B.10.A The first letter is identical to the Section letter i.e. Chapter B.10 is inside Section B, Power Production.

CONTENTS

The Chapter Contents lists all the **(D)** technical data (specifications), **(C)** functional data (how it works), **(F)** service data (remove, install adjust, etc..) and **(G)** diagnostic data (fault codes and troubleshooting) that have been written in that Chapter for that function or system on the machine.

Contents

POWER PRODUCTION		
ENGINE _ 10.A		
TECHNICAL DATA		
ENGINE - General specification (B.10.A - D.40.A.10)		3
FUNCTIONAL DATA		
ENGINE - Dynamic description (B.10.A - C.30.A.10)		4
SERVICE		
ENGINE - Remove (B.10.A - F.10.A.10)		5
DIAGNOSTIC		
ENGINE - Troubleshooting (B.10.A - G.40.A.10)		6

INDEX

The Chapter Index lists in alphabetical order all the types of information (called Information Units) that have been written in that Chapter for that function or system on the machine.

Index

POWER PRODUCTION - B ENGINE		
ENGINE - Dynamic description (B.10.A - C.30.A.10)		4
ENGINE - General specification (B.10.A - D.40.A.10)		3
ENGINE - Remove (B.10.A - F.10.A.10)		5
ENGINE - Troubleshooting (B.10.A - G.40.A.10)		6

Information Units and Information Search

Each chapter is composed of information units. Each information unit has the ICE code shown in parentheses which indicates the function and the type of information written in that information unit. Each information unit has a page reference within that Chapter. The information units provide a quick and easy way to find just the right piece of technical information you are looking for.

example information unit	Stack valve - Sectional View (A.10.A.18 - C.10.A.30)				
Information Unit ICE code	A	10.A	18	C	10.A.30
ICE code classification	Distribution systems	Primary hydraulic power	Stack valve	Functional data	Sectional view

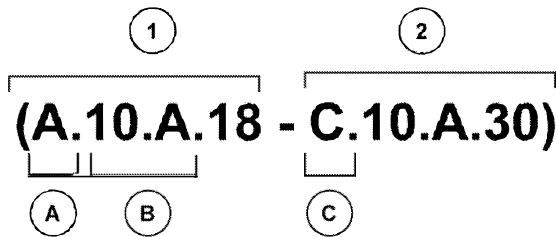

CRIL03J033E01 1

Navigate to the correct information unit you are searching for by identifying the function and information type from the ICE code.

- (1) Function and (2) Information type.
- (A) corresponds to the sections of the repair manual.
(B) corresponds to the chapters of the repair manual.
(C) corresponds to the type of information listed in the chapter contents, (D) Technical data, (E) Functional Data, (G) Diagnostic or (F) Service.
(A) and (B) are also shown in the page numbering on the page footer.
THE REST OF THE CODING IS NOT LISTED IN ALPHA-NUMERIC ORDER IN THIS MANUAL.
- You will find a table of contents at the beginning and end of each section and chapter.
You will find an alphabetical index at the end of each chapter.
- By referring to (A), (B) and (C) of the coding, you can follow the contents or index (page numbers) and quickly find the information you are looking for.

Page Header and Footer

The page header will contain the following references:

- Section and Chapter description

The page footer will contain the following references:







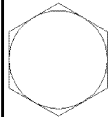

- Publication number for that Manual, Section or Chapter.
- Version reference for that publication.
- Publication date
- Section, chapter and page reference e.g. A.10.A / 9

Torque

BOLT TORQUE INFORMATION

DECIMAL HARDWARE

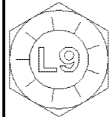
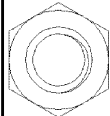
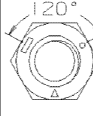
1. Fasteners should be replaced with the same or higher grade. If higher grade fasteners are used, these should only be tightened to the strength of the original.
2. Make sure the fasteners threads are clean and that thread engagement is started. This will prevent them from failing when being tightened.
3. Tighten plastic insert or crimped steel-type lock nuts to approximately **50 %** of the dry torque, applied to the nut, not to the bolt head. Tighten toothed or serrated-type lock nuts to the full torque value.
4. The L9 (Alloy) fasteners torque values are for a bolt, nut, and two washers.
When using L9 (Alloy) fasteners, do not use the values in this table for tapped holes.

GRADE							
	1 or 2	5	5.1	5.2	8	8.2	L9 (Alloy)
SAE Markings for Bolts and Cap Screws							
SAE Markings for Hex Nuts							

SIZE	GRADE 2 *				GRADE 5, 5.1 or 5.2				GRADE 8 or 8.2				GRADE L9 (Alloy)			
	Dry **		Lubricated **		Dry**		Lubricated **		Dry**		Lubricated **		Head		Nut	
	Nm	lb/ft	Nm	lb/ft	Nm	lb/ft	Nm	lb/ft	Nm	lb/ft	Nm	lb/ft	Nm	lb/ft	Nm	lb/ft
1/4 UNF	7.5	5.5	5.7	4.2	10.8	8	8.5	6.3	16.3	12	12.2	9	13.6	10	14.9	11
1/4 UNC	8.5	6.3	6.4	4.7	13.6	10	9.8	7.2	19	14	13.6	10	16.3	12	17.6	13
5/16 UNF	15	11	11	8	23	17	18	13	33	24	24	18	26	19	28	21
5/16 UNC	16	12	12	9	26	19	19	14	37	27	27	20	27	20	31	23
3/8 UNF	27	20	20	15	41	30	31	23	61	45	47	35	41	30	45	33
3/8 UNC	31	23	23	17	47	35	34	25	68	50	47	35	47	35	52	38
7/16 UNF	43	32	33	24	68	50	47	35	95	70	68	50	75	55	81	60
7/16 UNC	49	36	37	27	75	55	54	40	108	80	81	60	81	60	88	65
1/2 UNF	68	50	47	35	102	75	75	55	149	110	108	80	115	85	129	95
1/2 UNC	75	55	54	40	115	85	88	65	163	120	122	90	129	95	142	105
9/16 UNF	95	70	75	55	149	110	108	80	203	150	149	110	163	120	190	140
9/16 UNC	108	80	81	60	163	120	122	90	231	170	176	130	183	135	203	150
5/8 UNF	136	100	102	75	203	150	149	110	285	210	217	160	231	170	251	185

INTRODUCTION

SIZE	GRADE 2 *				GRADE 5, 5.1 or 5.2				GRADE 8 or 8.2				GRADE L9 (Alloy)			
	Dry **		Lubricated **		Dry**		Lubricated **		Dry**		Lubricated **		Head		Nut	
	Nm	lb/ft	Nm	lb/ft	Nm	lb/ft	Nm	lb/ft	Nm	lb/ft	Nm	lb/ft	Nm	lb/ft	Nm	lb/ft
5/8 UNC	149	110	115	85	231	170	176	130	325	240	244	180	258	190	278	205
3/4 UNF	237	175	176	130	353	260	271	200	515	380	380	280	359	265	393	290
3/4 UNC	271	200	190	140	407	300	298	220	570	420	420	310	447	330	481	355
7/8 UNF	231	170	170	125	583	430	434	320	814	600	610	450	644	475	685	505
7/8 UNC	244	180	190	140	637	470	475	350	909	670	678	500	705	520	793	585
1 UNF	339	250	258	190	868	640	651	480	1234	910	922	680	746	550	1051	775
1 UNC	380	280	285	210	976	720	732	540	1383	1020	1031	760	949	700	1220	900
1-1/8 UNF	475	350	366	270	1071	790	800	590	1749	1290	1315	970	1390	1025	1559	1150
1-1/8 UNC	542	400	407	300	1207	890	909	670	1953	1440	1464	1080	1559	1150	1797	1325
1-1/4 UNF	678	500	515	380	1519	1120	1139	840	2468	1820	1844	1360	1898	1400	2170	1600
1-1/4 UNC	746	550	570	420	1681	1240	1261	930	2726	2010	2048	1510	2170	1600	2373	1750
1-1/2 UNF	1180	870	881	650	2644	1950	1980	1460	4285	3160	3214	2370	3932	2900	4407	3250
1-1/2 UNC	1329	980	990	730	2983	2200	2224	1640	4827	3560	3621	2670	4475	3300	4949	3650

IMPORTANT: DO NOT use these values if a different torque value or tightening procedure is given for a specific application. Torque values listed are for general use only. Check tightness of fasteners periodically. Shear bolts are designed to fail under predetermined loads. Always replace shear bolts with identical grade.

NOTES

- * - Grade 2 applies for hex caps (not hex bolts) up to **152 mm (6 in)** long. Grade 1 applies for hex cap screws over **152 mm (6 in)** long, and for all other types of bolts and screws of any length.
- ** - "Lubricated" means coated with a lubricant such as engine oil, or fasteners with phosphate and oil coatings. "Dry" means plained or zinc plated without any lubrication.

TORQUE SPECIFICATIONS - METRIC HARDWARE

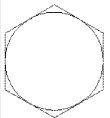
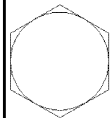
GRADE 8.8 Bolts, Nuts and Studs				GRADE 10.9 Bolts, Nuts and Studs		
Dry				Dry		
SIZE	Nm	lb/in	lb/ft	Nm	lb/in	lb/ft
						
M4	3 to 4	31 to 35		5 to 6	44 to 49	
M5	5 to 6	49 to 55		8 to 9	71 to 79	
M6	10 to 11	84 to 94		14 to 15	120 to 136	
M8	23 to 26	229 to 277		33 to 37	293 to 329	
M10	46 to 51	408 to 460		65 to 74		48 to 54
M12	80 to 90		59 to 66	114 to 128		85 to 94
M14	128 to 145		94 to 106	183 to 205		136 to 153
M16	200 to 220		149 to 161	285 to 320		208 to 235
M20	400 to 450		293 to 330	555 to 620		406 to 460
M24	690 to 780		510 to 575	955 to 1075		705 to 790

INTRODUCTION

GRADE 8.8 Bolts, Nuts and Studs				GRADE 10.9 Bolts, Nuts and Studs		
Dry				Dry		
SIZE	Nm	lb/in	lb/ft	Nm	lb/in	lb/ft
M30	1375 to 1545		1010 to 1140	1900 to 2140		1400 to 1580
M36	2400 to 2700		1770 to 1990	3315 to 3730		2445 to 2750

Use the above torques when specifications are not given.

These values apply to fasteners with both coarse and fine threads as received from supplier, plated or unplated, or when lubricated with engine oil. These values do not apply if graphite or Molydisulfide grease or oil is used. Use of a click type torque wrench, or better is required.

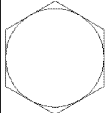
Grade 12.9 Bolts, Nuts, and Studs

Usually torque values specified to grade 10.9 fasteners can be used satisfactorily on grade 12.9 fasteners.

TORQUE SPECIFICATIONS - STEEL HYDRAULIC FITTINGS

37 Degree Flare Fitting						
Nom. SAE Dash Size	Tube OD/Hose ID	Thread Size	Newton metres	lb/in	lb/ft	
-2		5/16 - 24	8 to 9	72 to 84		
-3		3/8 - 24	11 to 12	96 to 108		
-4	6.4 mm	1/4 inch	7/16 - 20	14 to 16	120 to 144	
-5	7.9 mm	5/16 inch	1/2 - 20	18 to 21	156 to 192	
-6	9.5 mm	3/8 inch	9/16 - 18	27 to 33	240 to 300	
-8	12.7 mm	1/2 inch	3/4 - 16	46 - 56	408 to 504	
-10	15.9 mm	5/8 inch	7/8 - 14	77 to 85	684 to 756	
-12	19.0 mm	3/4 inch	1-1/16 - 12	107 to 119		79 to 88
-14	22.2 mm	7/8 inch	1-3/16 - 12	127 to 140		94 to 103
-16	25.4 mm	1.0 inch	1-5/16 - 12	131 to 156		97 to 117
-20	31.8 mm	1-1/4 inch	1-5/8 - 12	197 to 223		145 to 165
-24	38.1 mm	1-1/2 inch	1-7/8 - 12	312 to 338		230 to 250

Straight Thread with O-ring						
Nom. SAE Dash Size	Tube OD/Hose ID	Thread Size	Newton metres	lb/in	lb/ft	
-2		5/16 - 24	8 to 9	72 to 84		
-3		3/8 - 24	11 to 12	96 to 108		
-4	6.4 mm	1/4 inch	7/16 - 20	20 to 25	180 to 228	
-5	7.9 mm	5/16 inch	1/2 - 20	27 to 33	240 to 300	
-6	9.5 mm	3/8 inch	9/16 - 18	43 to 54	384 to 480	
-8	12.7 mm	1/2 inch	3/4 - 16	73 to 90	648 to 804	
-10	15.9 mm	5/8 inch	7/8 - 14	100 to 124		74 to 92
-12	19.0 mm	3/4 inch	1-1/16 - 12	138 to 173		102 to 128
-14	22.2 mm	7/8 inch	1-3/16 - 12	173 to 216		128 to 160
-16	25.4 mm	1.0 inch	1-5/16 - 12	203 to 253		150 to 187
-20	31.8 mm	1-1/4 inch	1-5/8 - 12	308 to 357		227 to 264
-24	38.1 mm	1-1/2 inch	1-7/8 - 12	492 to 542		363 to 400

Split Flange Mounting Bolts			
Size	Newton metres	lb/in	lb/ft
5/16 - 18	20 to 27	180 to 240	
3/8 - 16	27 to 34	240 to 300	
7/16 - 14	47 to 61	420 to 540	
1/2 - 13	74 to 88		55 to 65
5/8 - 11	190 to 203		140 to 150

INTRODUCTION

O-Ring Face Seal End						
Nom. SAE Dash Size	Tube OD		Thread Size	Newton metres	lb/in	lb/ft
-4	6.4 mm	1/4 inch	9/16 - 18	23 to 26	204 to 228	
-6	9.5 mm	3/8 inch	11/16 - 16	34 to 40	300 to 348	
-8	12.7 mm	1/2 inch	13/16 - 16	52 to 57	456 to 504	
-10	15.9 mm	5/8 inch	1-14	81 to 90	720 to 792	
-12	19.0 mm	3/4 inch	1-3/16 - 12	117 to 128		86 to 94
-16	25.4 mm	1.0 inch	1-7/16 - 12	152 to 174		112 to 128
-20	31.8 mm	1-1/4 inch	1-11/16 - 12	179 to 201		132 to 148
-24	38.1 mm	1-1/2 inch	2 - 12	213 to 235		157 to 173

O-Ring Boss End Fitting or Lock Nut				
Nom. SAE Dash Size	Thread Size	Newton metres	lb/in	lb/ft
-6	9/16 - 18	48 to 54	432 to 480	
-8	3/4 - 16	70 to 78	612 to 684	
-10	7/8 - 14	102 to 114		75 to 84
-12	1-1/16 - 12	142 to 160		105 to 117
-16	1-5/16 - 12	237 to 254		175 to 187

Pipe Fitting		
Nom. SAE Dash Size	Thread Size	TFFT (Turns For Finger Tight)
-2	1/8 - 27	2.0 - 3.0
-3	1/8 - 27	2.0 - 3.0
-4	1/8 - 27	2.0 - 3.0
-5	1/8 - 27	2.0 - 3.0
-6	1/4 - 18	1.5 - 3.0
-8	3/8 - 18	2.0 - 3.0
-10	1/2 - 14	2.0 - 3.0
-12	3/4 - 14	2.0 - 3.0
-14	3/4 - 14	2.0 - 3.0
-16	1 - 11-1/2	1.5 - 2.5
-20	1-1/4 - 11-1/2	1.5 - 2.5
-24	1-1/2 - 11-1/2	1.5 - 2.5
-32	2 - 11-1/2	1.5 - 2.5

NOTE: Apply sealant/lubricant to male pipe threads. The first two threads should be left uncovered to avoid system contamination. Screw pipe fitting into female pipe port to the finger tight position. Wrench tighten fitting to the appropriate turns from finger tight (TFFT) shown in table above, making sure the tube end of an elbow or tee fitting is aligned to receive incoming tube or hose fitting.

Consumables

Environment

Before you service this machine and dispose of oil, fluids and lubricants, always remember the environment. Do not put oil or fluids into the ground or into containers that can leak. Check with your local environmental, recycling center of your Case dealer for correct disposal information.



BS00H001 1

Engine Oil Selection

Case No. 1 Engine Oil is recommended for use in your Case Engine. Case Engine Oil will lubricate your engine correctly under all operating conditions.



RH99K130 2

See the chart below for recommended viscosity at ambient temperature ranges.

NOTE: Do not put Performance Additives or other oil additive products in the engine crankcase. The oil change intervals given in the operating manual are according to tests with Case lubricants.

INTRODUCTION

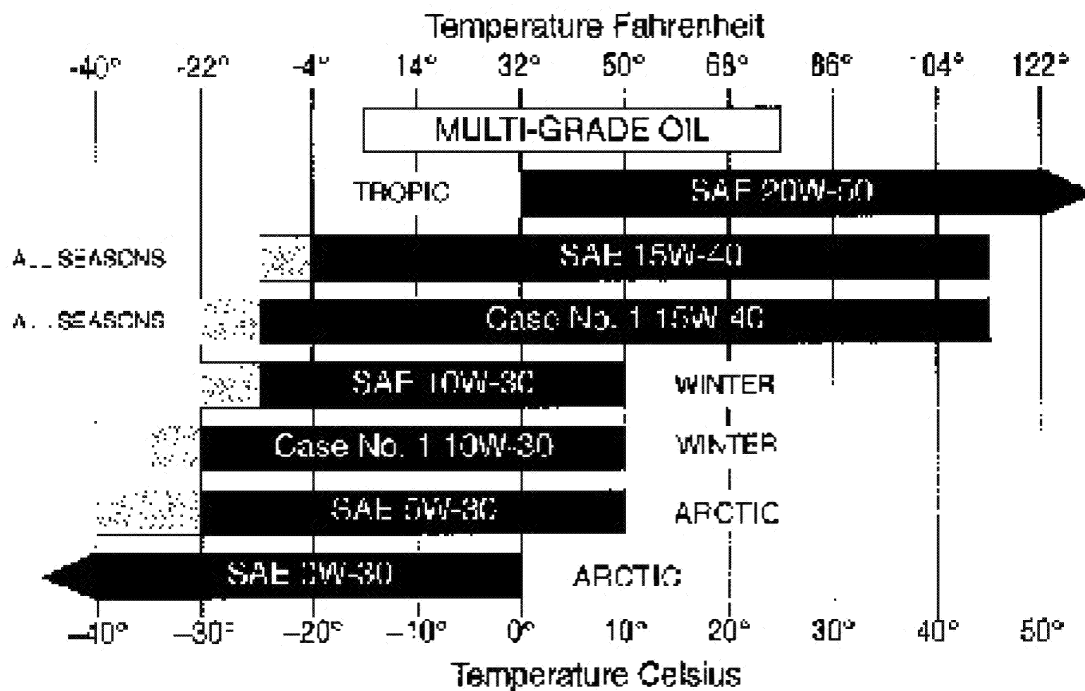

 indicates use of an engine oil heater or a Jackal water heater is required.

BS99N019 3

Before you service this machine and dispose of oil, fluids and lubricants, always remember the environment. Do not put oil or fluids into the ground or into containers that can leak. Check with your local environmental, recycling center or your Case dealer for correct disposal information.

LOCTITE PRODUCT CHART

Product	Color	Similar Products	Gap (In Inches)	Strength (Steel/Steel)	Working Temperature Range-Fahrenheit	Fixture/Full Cure (Steel/Steel) Time	Primer	Description
#3	Dark Brown					24 hr	N/A	Form a Gasket (works with oil, fuel or grease) Pliable
80	Yellow					Fast	N/A	Weatherstrip Adhesive
128	Clear					N/A	N/A	Parts Cleaner Fluid
220	Blue	290	0.003	57/143 in lbs	-65 to +250	6 min/24 hrs	747	Wicking Threadlocker
221	Purple	222	0.005	75/44 in lbs	-65 to +300	2 min/24 hrs	747	Low Strength Threadlocker
222	Purple		0.005	53/30 in lbs	-65 to +300	20 min/24 hrs	764	Low Strength Threadlocker (Small Screws)
225	Brown	222	0.010	45/25 in lbs	-65 to +300	7 min/24 hrs	747	Low Strength Threadlocker
242	Blue		0.005	80/50 in lbs	-65 to +300	10 min/24 hrs	764	Medium Strength Threadlocker
262	Red	271	0.005	160/190 in lbs	-65 to +300	5 min/24 hrs	747	High Strength Threadlocker
270	Green	271	0.007	160/320 in lbs	-65 to +300	3 min/24 hrs	747	High Strength Threadlocker
271	Red	262	0.007	160/320 in lbs	-65 to +300	10 min/24 hrs	764	High Strength Threadlocker
272	Red	262	0.007	180/220 in lbs	-65 to +450	30 min/24 hrs	764	High Temperature, High Strength
275	Green	277	0.010	210/300 in lbs	-65 to +300	3 min/24 hrs	747	High Strength Threadlocker
277	Red		0.010	225/300 in lbs	-65 to +300	60 min/24 hrs	764	High Strength Threadlocker
290	Green		0.003	85/350 in lbs	-65 to +300	6 min/24 hrs	764	Wicking Threadlocker
*404	Clear	454	0.006	3200 psi	-65 to +180	30 sec/24 hrs	N/A	Instant Adhesive
*406	Clear		0.004	3200 psi	-65 to +180	15 sec/24 hrs	N/A	Surface Insensitive Adhesive
*409	Clear	454	0.008	2500 psi	-65 to +180	50 sec/24 hrs	N/A	Gel Instant Adhesive
*414	Clear		0.006	2500 psi	-65 to +180	30 sec/24 hrs	N/A	Instant Adhesive
*415	Clear	454	0.010	2500 psi	-65 to +180	60 sec/24 hrs	N/A	Gap Filling Instant Adhesive (Metals)
*416	Clear	454	0.010	2500 psi	-65 to +180	50 sec/24 hrs	N/A	Gap Filling Instant Adhesive (Plastics)
*420	Clear		0.002	2500 psi	-65 to +180	15 sec/24 hrs	N/A	Wicking Instant Adhesive
*422	Clear	454	0.020	2500 psi	-65 to +180	60 sec/24 hrs	N/A	Gap Filling Instant Adhesive
*430	Clear		0.005	2500 psi	-65 to +180	20 sec/24 hrs	N/A	Metal Bonding Adhesive
*445	White/Black		0.250	2000 psi	-65 to +180	5 min/24 hrs	N/A	Fast Setting 2 Part Epoxy
*454	Clear		0.010	3200 psi	-65 to +180	15 sec/24 hrs	N/A	Surface Insensitive Gen Instant Adhesive
*495	Clear		0.004	2500 psi	-65 to +180	20 sec/24 hrs	N/A	General Purpose Instant Adhesive
*496	Clear		0.005	2500 psi	-65 to +180	20 sec/24 hrs	N/A	Metal Bonding Adhesive
504	Brt Orange	515	0.030	750 psi	-65 to +300	90 min/24 hrs	None	Rigid Gasket Eliminator
509	Light Blue		0.020	750 psi	-65 to +300	6 hr/72 hrs	764	Flange Sealant
510	Red		0.020	1000 psi	-65 to +400	30 min/24 hrs	764	High Temperature Gasket Eliminator
515	Purple		0.010	750 psi	-65 to +300	1 hr/24 hrs	764	Gasket Eliminator b15

Rev 6-98802

* Products 404-496 (except for #445) are all instant adhesives (except gels) they differ mostly in viscosity

Printed in U.S.A

LOCTITE PRODUCT CHART

Product	Color	Similar Products	Gap (In Inches)	Strength (Steel/Steel)	Working Temperature Range-Fahrenheit	Fixture/Full Cure (Steel/Steel) Time	Primer	Description
518	Red	515	0.030	500psi	-65 to +300	1 hr/24 hrs	764	Gasket Eliminator 518 for Aluminum
542	Brown	569	N/A	132/92 in lbs	-65 to +300	2 hr/24 hrs	747	Hydraulic Sealant
545	Purple		N/A	25/20 in lbs	-65 to +300	4 hr/24 hrs	747	Low Strength Pneumatic/Hydraulic Sealant
549	Orange	504	0.020	2500 psi	-65 to +300	2 hr/24 hrs	747	Instant Seal Plastic Gasket
554	Red	277	0.015	240/240 in lbs	-65 to +300	2 to 4 hrs/24 hrs	764	Refrigerant Sealant
567	White	592	N/A	500 psi	-65 to +400	4 hrs/24 hrs	764	Pipe Sealant for Stainless Steel
568	Orange	277	0.015	2500 psi	-65 to +300	12 hrs/24 hrs	764	Plastic Gasket
569	Brown	545	0.010	40/25 in lbs	-65 to +300	1 hr/24 hrs	764	Hydraulic Sealant
570	Brown	592	N/A	25/40 in lbs	-65 to +300	6 hrs/72 hrs	764	Steam Sealant
571	Brown	592	0.015	40/20 in lbs	-65 to +300	2 to 4 hrs/24 hrs	764	Pipe Sealant
572	White	578,575	N/A	80/27 in lbs	-65 to +300	24 hrs/72 hrs	None	Gasketing
592	White		0.020	500 psi	-65 to +400	4 hrs/72 hrs	736	Pipe Sealant with Teflon
593	Black		0.250	400 psi	-95 to +400	30 min/24 hrs	N/A	RTV Silicone
601	Green	609	0.005	3000 psi	-65 to +300	10 min/24 hrs	764	Current PIN #609
609	Green		0.005	3000 psi	-65 to +300	10 min/24 hrs	764	General Purpose Retaining Compound
620	Green	640	0.015	3000 psi	-65 to +450	30 min/24 hrs	747	High Temperature Retaining Compound
635	Green	680	0.010	4000 psi	-65 to +300	1 hr/24 hrs	747	High Strength Retaining Compound
638	Green	680	0.015	4100 psi	-65 to +300	10 min/24 hrs	747	High Strength Retaining Compound
640	Green	620	0.007	3000 psi	-65 to +400	1 hr/24 hrs	747	High Temperature Retaining Compound
660	Silver		0.020	3000 psi	-65 to +300	20 min/24 hrs	764	Quick Metal
675	Green	609	0.005	3000 psi	-65 to +300	20 min/24 hrs	747	General Purpose Retaining Compound
680	Green	635	0.015	4000 psi	-65 to +300	10 min/24 hrs	747	High Strength Retaining Compound
706	Clear	755	N/A	N/A	N/A	N/A	N/A	Cleaning Solvent
707	Amber		N/A	N/A	N/A	N/A	N/A	Activator for Structural Adhesives
736	Amber		N/A	N/A	N/A	N/A	N/A	Primer NF
738	Amber		N/A	N/A	N/A	N/A	N/A	Depend Activator
747	Yellow	N/A	N/A	N/A	N/A	N/A	N/A	Primer T
751	Clear		N/A	N/A	N/A	N/A	N/A	Activator for Structural Adhesives
755	Clear		N/A	N/A	N/A	N/A	N/A	Cleaning Solvent
764	Green		N/A	N/A	N/A	N/A	N/A	Primer N
767	Silver		N/A	N/A	-65 to +1600	N/A	N/A	Anti-Seize Lubricant

Printed in U.S.A.

INTRODUCTION

87634768 1 / 3/1/2008

14

hsd0021_1 5

INTRODUCTION

Conversion factors

Metric to U.S.			
	MULTIPLY	BY	TO OBTAIN
AREA:	square meter	10.763 91	square foot
	hectare	2.471 05	acre
FORCE:	newton	3.596 942	ounce force
	newton	2.224 809	pound force
LENGTH:	millimeter	0.039 370	inch
	meter	3.280 840	foot
	kilometer	0.621 371	mile
MASS:	kilogram	2.204 622	pound
MASS/AREA:	kilogram/hectare	0.000 466	ton/acre
MASS/ENERGY:	gr/kW/hr.	0.001 644	lbs/hp/hr.
MASS/VOLUME:	kg/cubic meter	1.685 555	lb/cubic yd.
POWER:	kilowatt	1.341 02	horsepower
PRESSURE:	kilopascal	0.145 038	lb/sq. inch
	bar	14.50385	lb/sq. inch
TEMPERATURE:	degree C	1.8 x C +32	degree F
TORQUE:	newton meter	8.850 748	lb/inch
	newton meter	0.737 562	lb/foot
VELOCITY:	kilometer/hr.	0.621 371	miles/hr.
VOLUME:	cubic centimeter	0.061 024	cubic inch
	cubic meter	35.314 66	cubic foot
	cubic meter	1.307 950	cubic yd.
	milliliter	0.033 814	ounce (US fluid)
	litre	1.056 814	quart (US liquid)
	litre	0.879 877	quart (Imperial)
	litre	0.264 172	gallon (US liquid)
litre	0.219 969	gallon (Imperial)	
VOLUME/TIME:	litre/min.	0.264 172	gallon/min. (US liquid)
	litre/min.	0.219 969	gallon/min. (Imperial)

U.S. to Metric			
	MULTIPLY	BY	TO OBTAIN
AREA:	square foot	0.092 903	square meter
	acre	0.404 686	hectare
FORCE:	ounce force	0.278 014	newton
	pound force	4.448 222	newton
LENGTH:	inch	25.4 *	millimeter
	foot	0.304 8 *	meter
	mile	1.609 344 *	kilometer
MASS:	pound	0.453 592	kilogram
	ounce	28.35	gram
MASS/AREA:	ton/acre	2241 702	kilogram/hectare
MASS/ENERGY:	lb/hp/hr	608.277 4	gr/kW/hr
MASS/VOLUME:	lb/cubic yd.	0.593 276	kg/cubic meter
POWER:	horsepower	0.745 700	kilowatt
PRESSURE:	lbs/sq. in	6.894 757	kilopascal
	lbs/sq. in	0.069	bar
	lbs/sq. in	0.070 303	kg/sq. cm
TEMPERATURE:	degree F	1.8 F - 32	degree C
TORQUE:	pound/inch	0.112 985	newton meter
	pound/foot	1.355 818	newton meter
VELOCITY:	miles/hr.	1.609 344 *	kilometer/hr.

INTRODUCTION

U.S. to Metric			
	MULTIPLY	BY	TO OBTAIN
VOLUME:	cubic inch	16.387 06	cubic centimeter
	cubic foot	0.028 317	cubic meter
	cubic yard	0.764.555	cubic meter
	ounce (US fluid)	29.573 53	milliliter
	quart (US liquid)	0.946 353	litre
	quart (Imperial)	1.136 523	litre
	gallon (US)	3.785 412	litre
	gallon (Imperial)	4.546 092	litre
VOLUME/TIME:	gallon/min.	3.785 412	litre/min.



REPAIR MANUAL
DISTRIBUTION SYSTEMS



435
445CT
445

Contents

DISTRIBUTION SYSTEMS - A

PRIMARY HYDRAULIC POWER SYSTEM 435 , 445CT , 445	A.10.A
SECONDARY HYDRAULIC POWER SYSTEM 435 , 445CT , 445	A.12.A
HIGH-FLOW HYDRAULIC POWER SYSTEM 435 , 445CT , 445	A.16.A
ELECTRICAL POWER SYSTEM 435 , 445CT , 445	A.30.A
LIGHTING SYSTEM 435 , 445CT , 445	A.40.A
HYDRAULIC COMMAND SYSTEM 435 , 445CT , 445	A.14.A



DISTRIBUTION SYSTEMS - A

PRIMARY HYDRAULIC POWER SYSTEM - 10.A

**435
445CT
445**

Contents

DISTRIBUTION SYSTEMS - A

PRIMARY HYDRAULIC POWER SYSTEM - 10.A

TECHNICAL DATA

PRIMARY HYDRAULIC POWER SYSTEM	
Capacity	5
General specification	5
Special tools	5
Relief valve	
General specification	7
Hydraulic pump	
General specification	8
Filter by-pass	
General specification	9

FUNCTIONAL DATA

PRIMARY HYDRAULIC POWER SYSTEM	
Identification	10
Hydraulic schematic frame 01	11
Hydraulic schematic frame 02	12
Hydraulic schematic frame 03	14
Hydraulic schematic frame 04	16
Hydraulic schematic frame 05	18
Hydraulic schematic frame 06	20
Hydraulic schematic frame 07	21
Hydraulic schematic frame 08	23
Hydraulic schematic frame 01 (ISO-Pattern Pilot Controls)	25
Hydraulic schematic frame 02 (ISO-Pattern Pilot Controls)	26
Hydraulic schematic frame 03 (ISO-Pattern Pilot Controls)	28
Hydraulic schematic frame 04 (ISO-Pattern Pilot Controls)	29
Hydraulic schematic frame 05 (ISO-Pattern Pilot Controls)	31
Hydraulic schematic frame 06 (ISO-Pattern Pilot Controls)	33
Hydraulic schematic frame 07 (ISO-Pattern Pilot Controls)	35
Hydraulic schematic frame 08 (ISO-Pattern Pilot Controls)	37
Hydraulic schematic frame 09 (ISO-Pattern Pilot Controls)	39
Hydraulic schematic frame 10 (ISO-Pattern Pilot Controls)	41
Hydraulic schematic frame 11 (H-Pattern Pilot Controls)	43
Hydraulic schematic frame 12 (H-Pattern Pilot Controls)	44
Hydraulic schematic frame 13 (H-Pattern Pilot Controls)	46

Hydraulic schematic frame 14 (H-Pattern Pilot Controls)	47
Hydraulic schematic frame 15 (H-Pattern Pilot Controls)	49
Hydraulic schematic frame 16 (H-Pattern Pilot Controls)	51
Hydraulic schematic frame 17 (H-Pattern Pilot Controls)	53
Hydraulic schematic frame 18 (H-Pattern Pilot Controls)	55
Hydraulic schematic frame 19 (H-Pattern Pilot Controls)	57
Hydraulic schematic frame 20 (H-Pattern Pilot Controls)	59
Hydraulic pump	
Sectional view	60
SERVICE	
PRIMARY HYDRAULIC POWER SYSTEM	
Cleaning	61
Decontaminating	65
Relief valve	
Flow test	67
Pressure test	69
Hydraulic pump	
Flow test	70
Remove	72
Remove (Machines Equipped with Pilot Controls)	74
Install (Machines Equipped with Pilot Controls)	75
Disassemble	77
Visual inspection	82
Assemble	84
Install	89
Charge pump	
Pressure test	92
Pressure test (Machines Equipped with Pilot Controls)	96
Reservoir	
Apply vacuum	98
Filling	99
Filter	
Remove	100
Install	102
Visual inspection	103
Oil cooler	
Remove	104
Remove (Tier 3 Certified Engines)	107
Install	108
Install (Tier 3 Certified Engines)	109
DIAGNOSTIC	
Sensing system	
Temperature sensor - Testing	110

Temperature sensor - Testing (Tier 3 Cab Up-Grade Machines)	110
Filter restriction sensor - Testing	110
Filter restriction sensor - Testing (Tier 3 Cab Up-Grade Machines)	111

PRIMARY HYDRAULIC POWER SYSTEM - Capacity

Hydraulic System	
Capacity - System 435 Machines	41.3 L (10.9 US gal)
Capacity - System 445/445CT Machines	41.5 L (11.0 US gal)
Capacity - System 450/450CT Machines	64.4 L (17 US gal)
Capacity - System 465 Machines	66.2 L (17.5 US gal)

PRIMARY HYDRAULIC POWER SYSTEM - General specification

Hydraulic System Oil	Type of Oil	Capacity
Total System (435 Machines)	CASE AKCELA NO. 1 ENGINE OIL SAE 10W-30	41.3 L (10.9 US gal)
Total System (445/445CT Machines)	CASE AKCELA NO. 1 ENGINE OIL SAE 10W-30	41.5 L (11 US gal)
Total System (450/450CT Machines)	CASE AKCELA NO. 1 ENGINE OIL SAE 10W-30	64.4 L (17 US gal)
Total System (465 Machines)	CASE AKCELA NO. 1 ENGINE OIL SAE 10W-30	66.2 L (17.5 US gal)
Chain Tank (435-445-450-465 Machines)	CASE AKCELA NO. 1 ENGINE OIL SAE 10W-30	Each Side 7.6 L (8.0 US qt)

PRIMARY HYDRAULIC POWER SYSTEM - Special tools

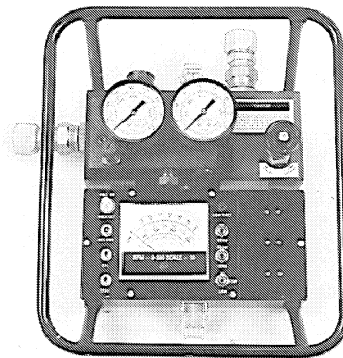

CAS 10280 1

CAS - 10280 Flowmeter

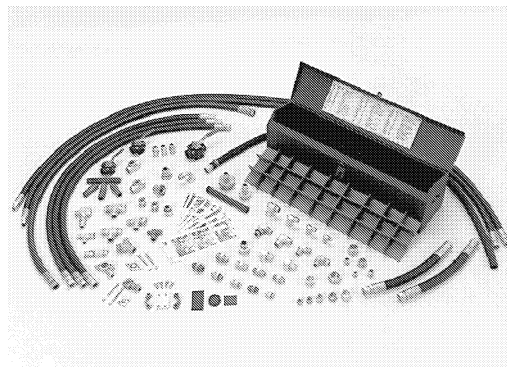

CAS 1808 2

CAS-1808 Flowmeter Fitting Kit

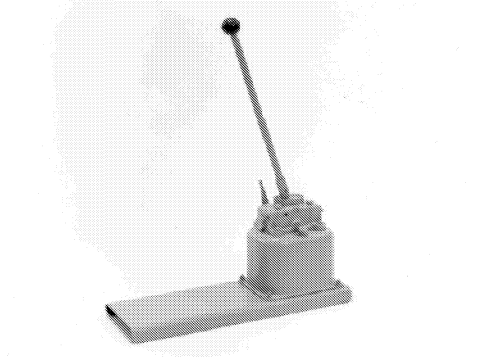

CAS10090 3

CAS-10090 Hand Pump



B877558M_1 4

CAS-1804 Pressure Test Fitting Kit

Relief valve - General specification

Loader Control Valve Relief Pressure Settings

Main Relief Pressure at 10 gpm

21290 kPa (210 bar) (3050 + 50/-72.5 psi) at 2200 RPM
--

Hydraulic pump - General specification

Hydraulic Pump	
Type	Gear
Displacement	36cc (2.2 in ³)
Flow at Engine Rated RPM at 100% Volumetric Efficiency	82.9 L/min (2.2 US gpm)

Filter by-pass - General specification

Return Filter	
Bypass Pressure	345 kPa (50 psi)

PRIMARY HYDRAULIC POWER SYSTEM - Identification

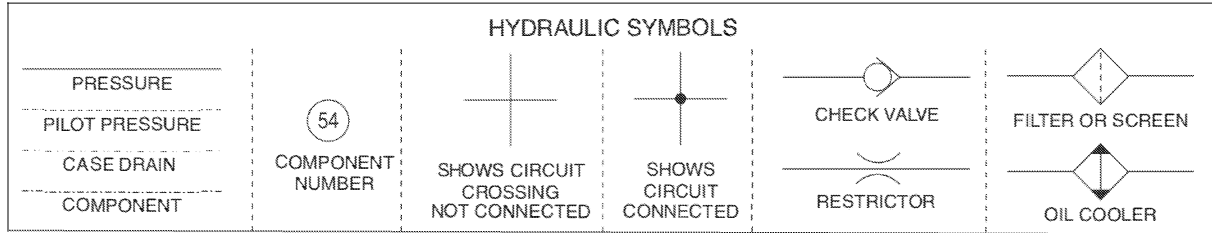

bs05e050 1

PRIMARY HYDRAULIC POWER SYSTEM - Hydraulic schematic frame 01

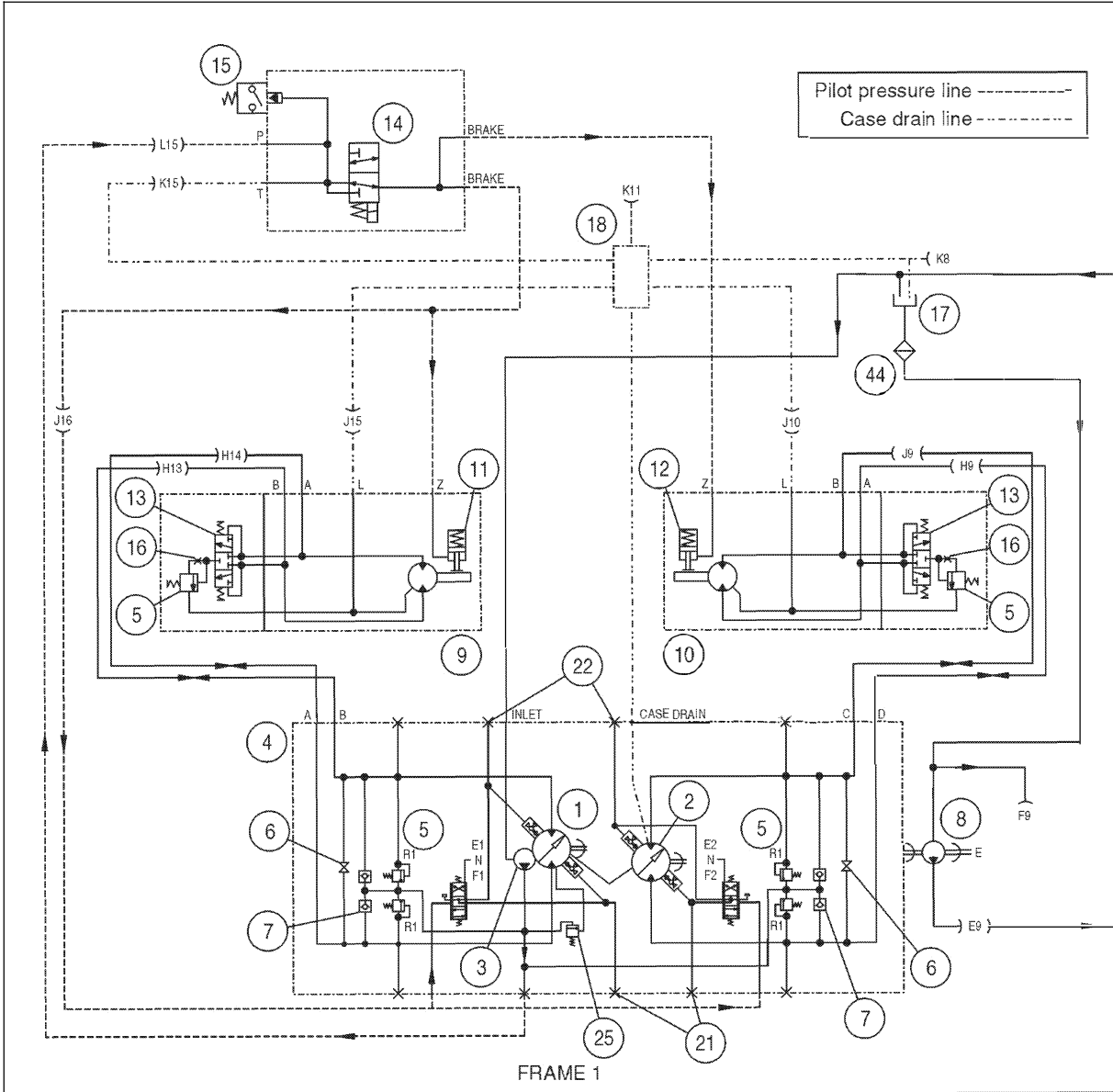

bc04h207-01 1

BC04H207-01

1. Left piston pump	9. Left drive motor	17. Hydraulic reservoir
2. Right piston pump	10. Right drive motor	18. Drain manifold
3. Charge pump	11. Left brake	21. Backup alarm switch ports
4. Hydrostatic pump	12. Right brake	22. Brake light switch ports
5. Circuit relief valve	13. Flushing valve	25. Main relief valve
6. Tow valve	14. Brake solenoid valve	44. 100 Mesh screen
7. Check valve	15. Charge pressure switch	
8. Hydraulic pump	16. Orifice	

PRIMARY HYDRAULIC POWER SYSTEM - Hydraulic schematic frame 02

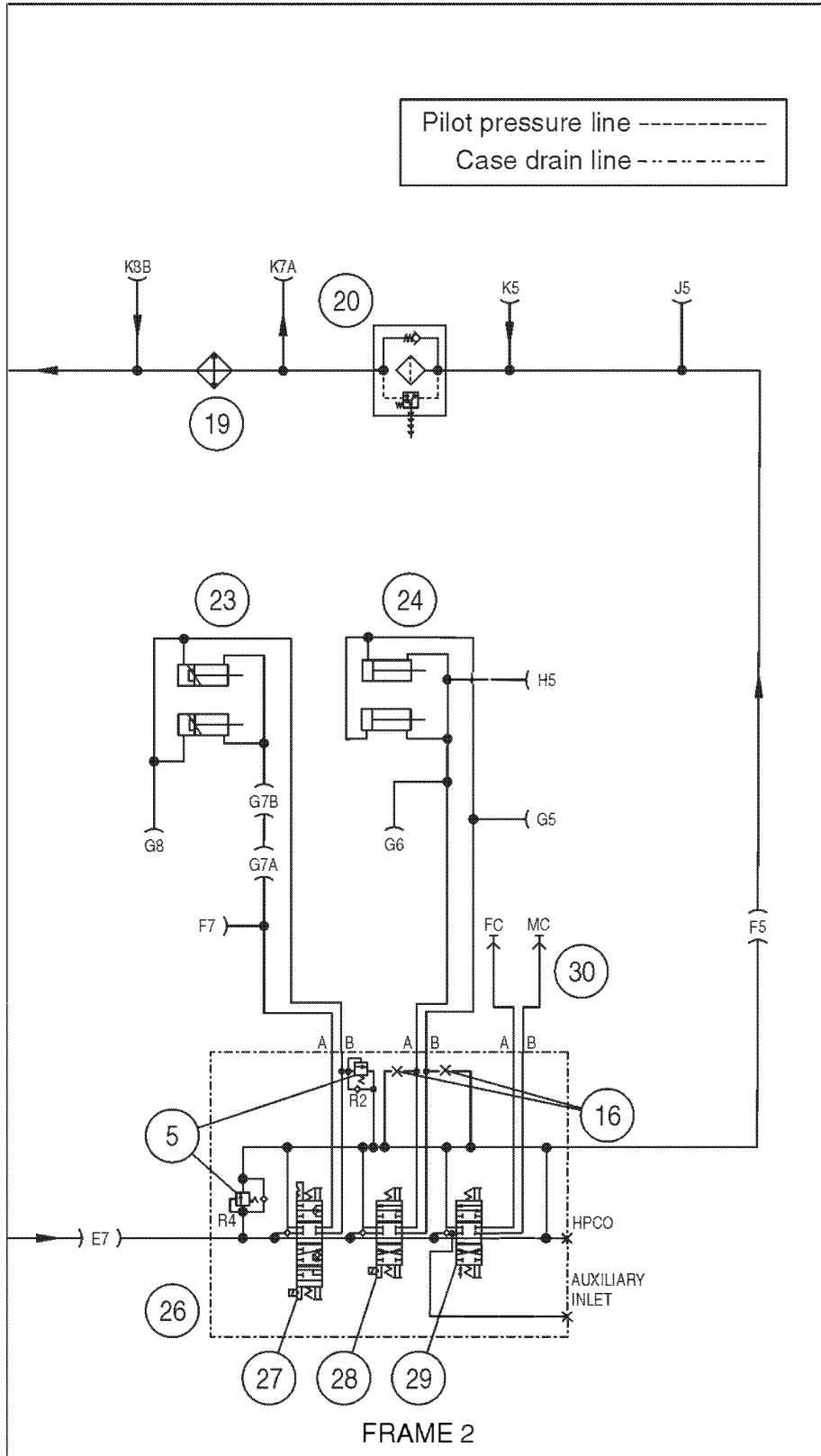

BC04H207-02

bc04h207-02 1

DISTRIBUTION SYSTEMS - PRIMARY HYDRAULIC POWER SYSTEM

5. Circuit relief valve	23. Tilt cylinders	28. Lift spool
26. Orifice	24. Lift cylinders	29. Auxiliary spool
19. Oil cooler	26. Loader control valve	30. Auxiliary outlets
20. Oil cooler bypass valve	27. Tilt spool	

PRIMARY HYDRAULIC POWER SYSTEM - Hydraulic schematic frame 03

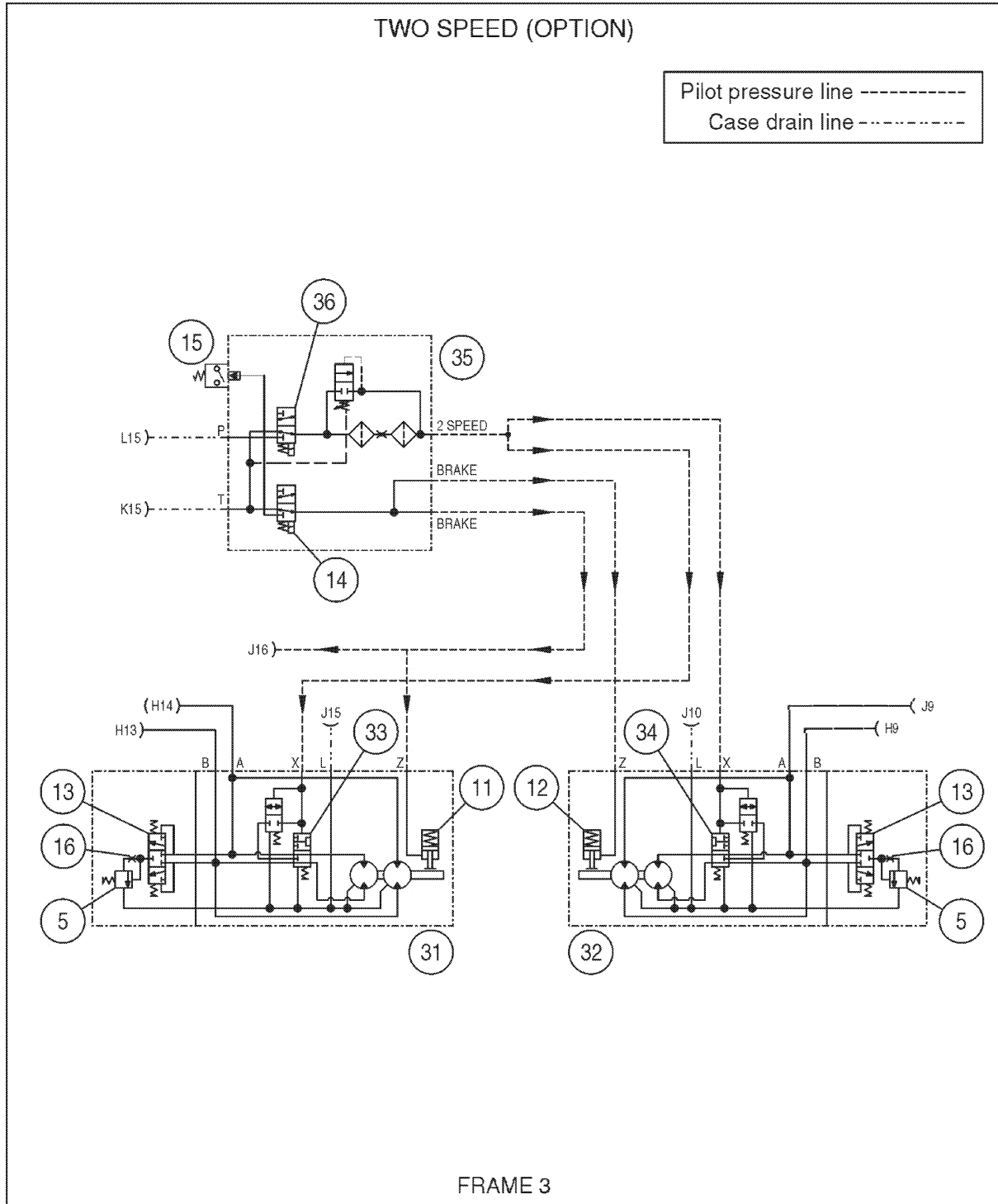

bc04h207-03 1

BC04H207-03

5. Circuit relief valve	15. Charge pressure switch	33. Left two speed shuttle valve
11. Left brake	16. Orifice	34. Right two speed shuttle valve
12. Right brake	31. Left two speed motor	35. Brake/two speed valve

DISTRIBUTION SYSTEMS - PRIMARY HYDRAULIC POWER SYSTEM

13. Flushing valve	32. Right two speed motor	36. Two speed solenoid valve
14. Brake solenoid valve		

PRIMARY HYDRAULIC POWER SYSTEM - Hydraulic schematic frame 04

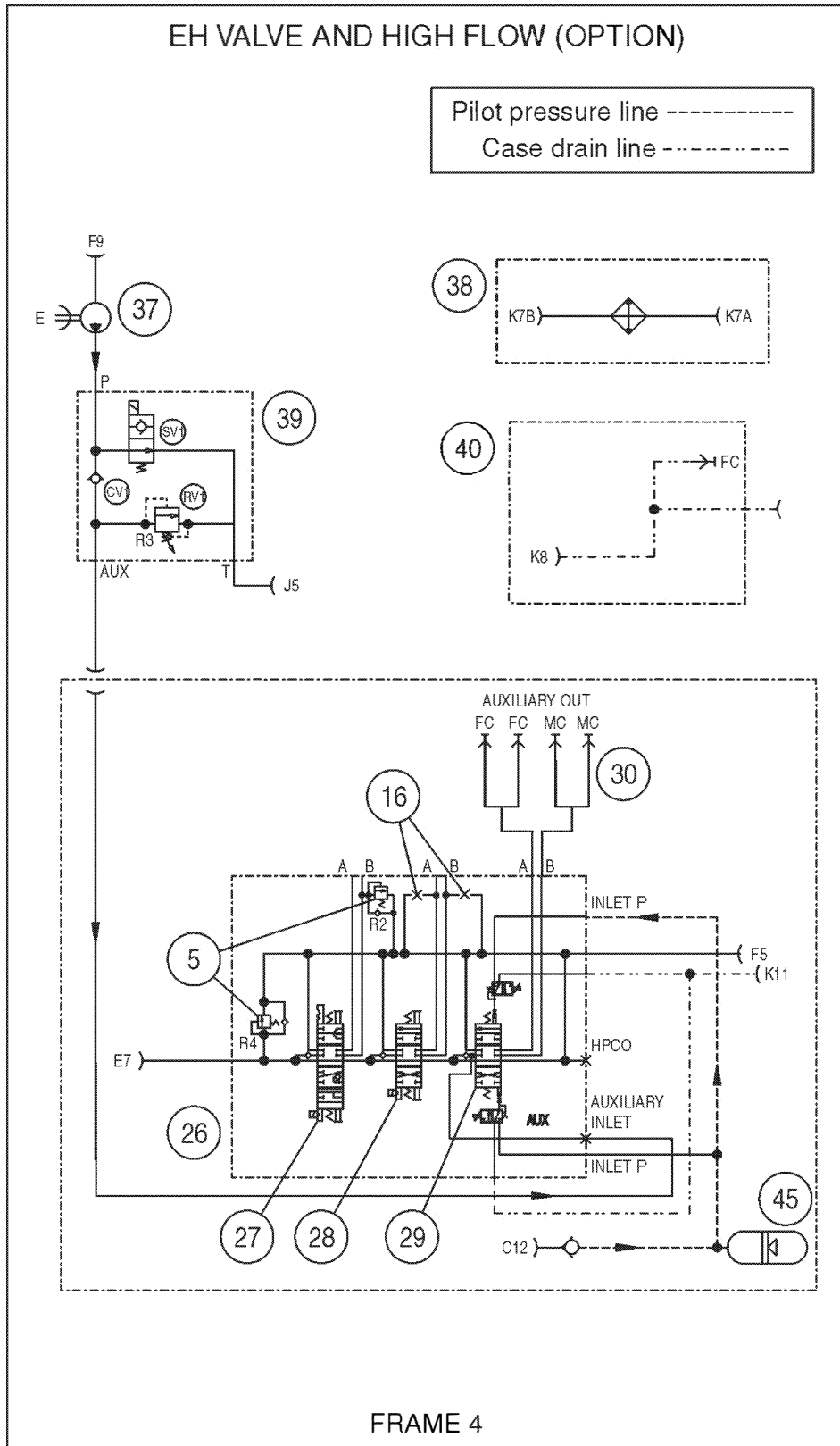

DISTRIBUTION SYSTEMS - PRIMARY HYDRAULIC POWER SYSTEM

5. Circuit relief valve	28. Lift spool	38. High flow oil cooler
16. Orifice	29. Auxiliary spool	39. High flow control valve
26. Loader control valve	30. Auxiliary outlets	40. Attachment case drain
27. Tilt spool	37. High flow pump	45. Accumulator

PRIMARY HYDRAULIC POWER SYSTEM - Hydraulic schematic frame 05

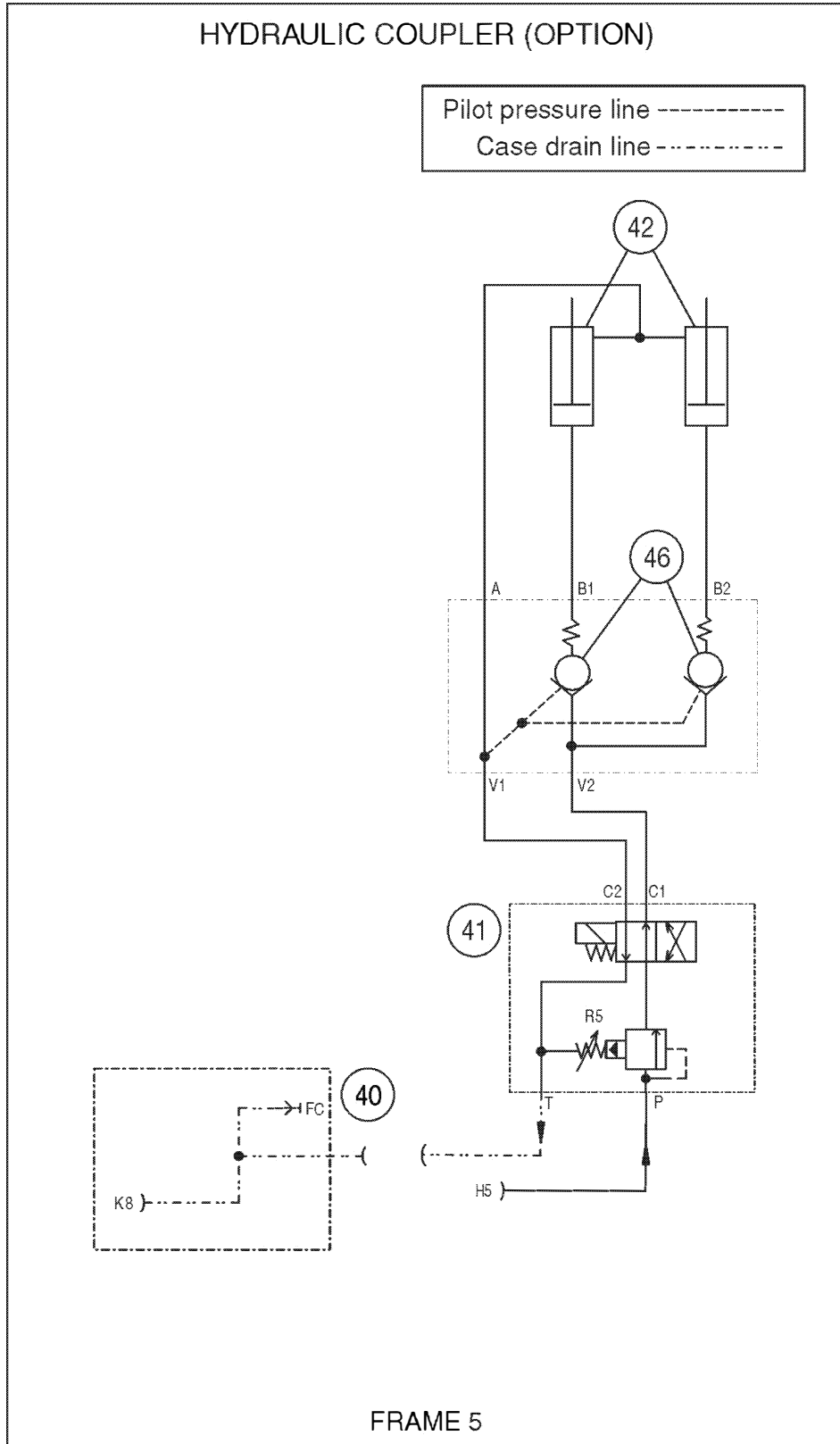

BC04H207-05

bc04h207-05 1

DISTRIBUTION SYSTEMS - PRIMARY HYDRAULIC POWER SYSTEM

40. Attachment case drain	42. Hydraulic coupler cylinder
41. Hydraulic coupler control valve	46. Check valve

PRIMARY HYDRAULIC POWER SYSTEM - Hydraulic schematic frame 06

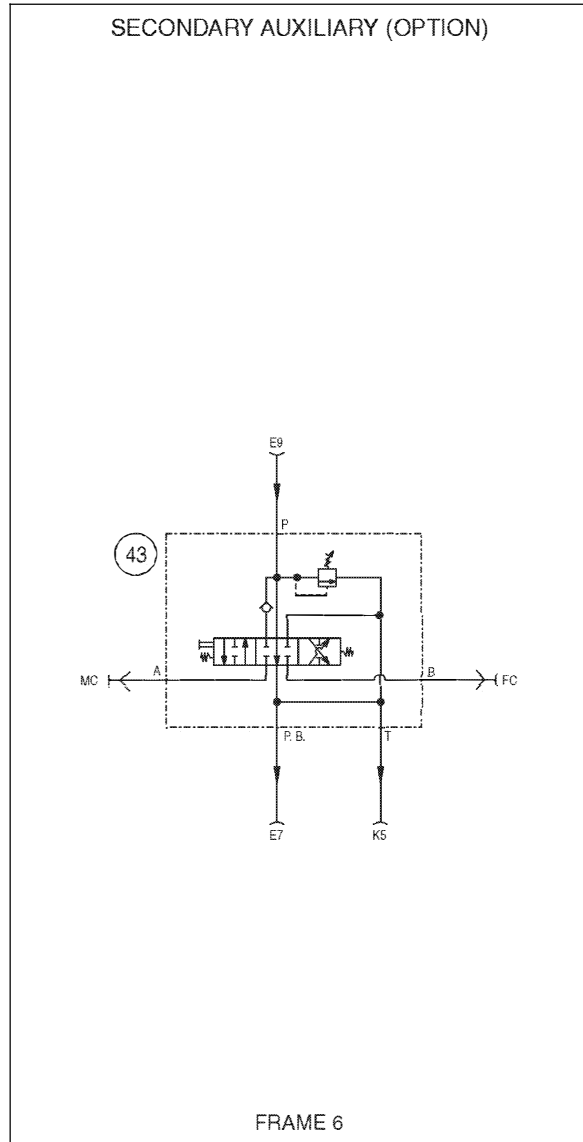

bc04h207-06 1

BC04H207-06

43. Secondary auxiliary control valve

PRIMARY HYDRAULIC POWER SYSTEM - Hydraulic schematic frame 07

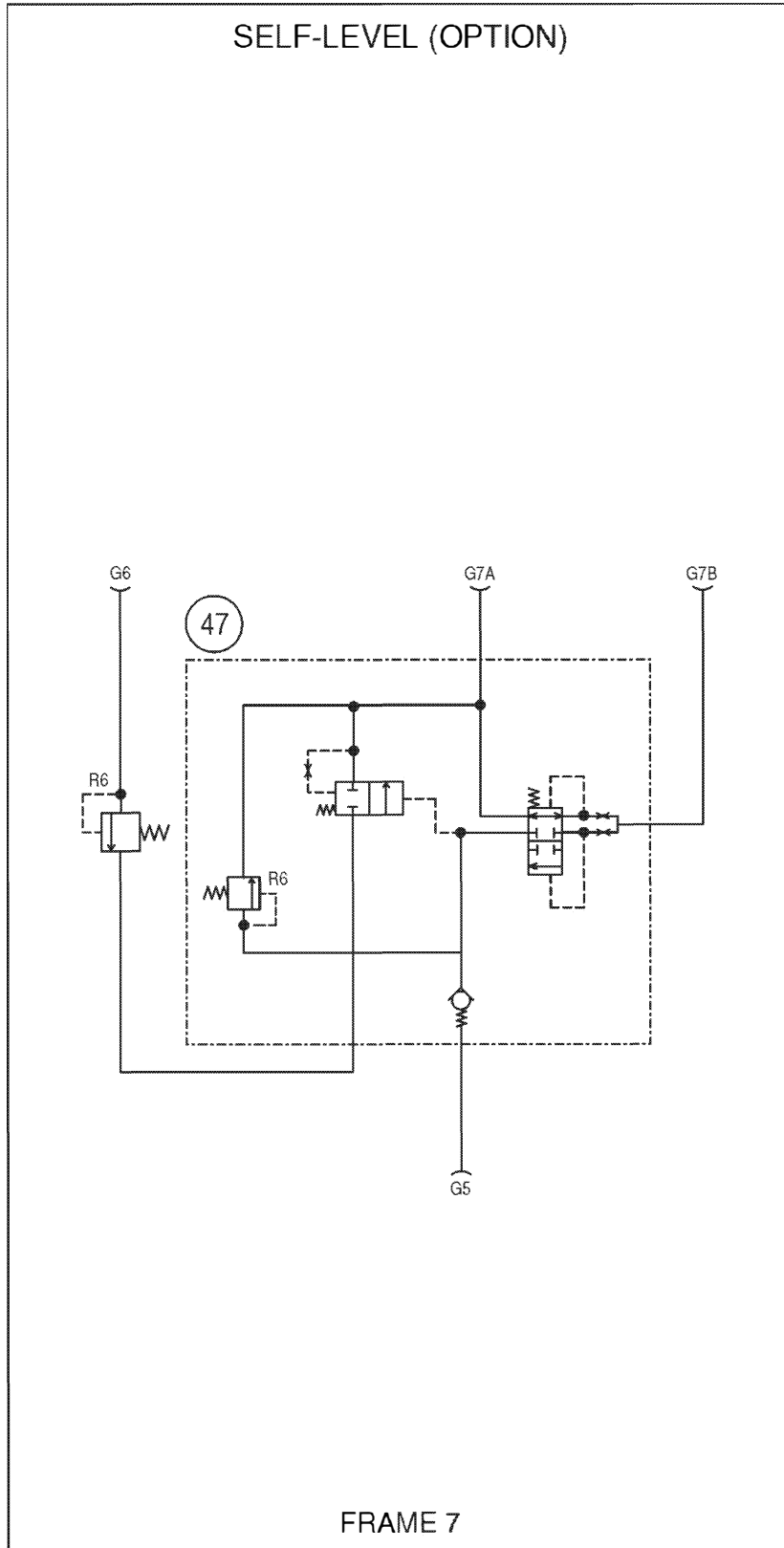

BC04H207-07

bc04h207-07 1

47. Self level valve

**PRIMARY HYDRAULIC POWER SYSTEM - Hydraulic schematic
frame 08**

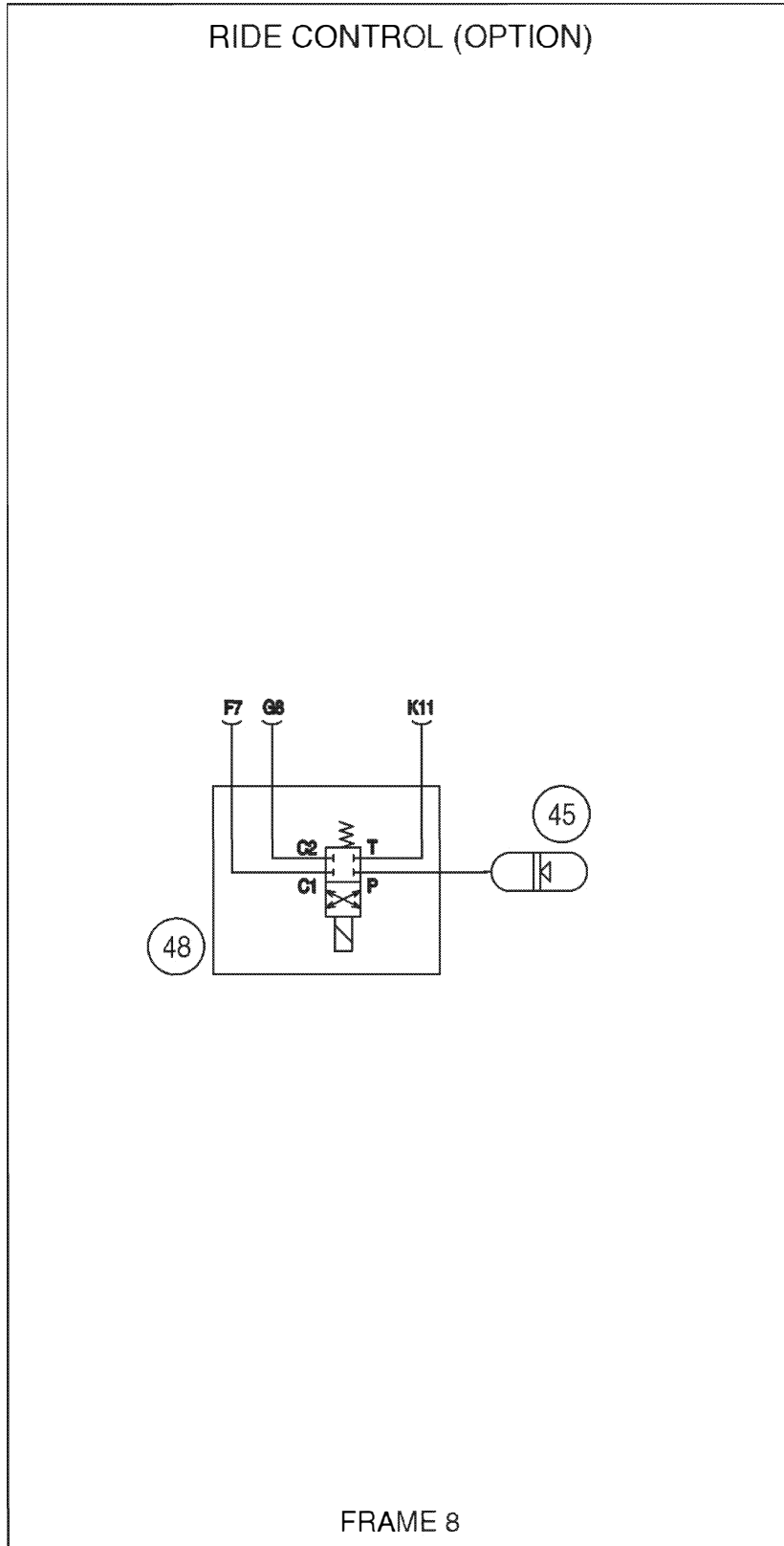

BC04H207-08

bc04h207-08 1

DISTRIBUTION SYSTEMS - PRIMARY HYDRAULIC POWER SYSTEM

45. Accumulator	48. Ride control solenoid valve
-----------------	---------------------------------

PRIMARY HYDRAULIC POWER SYSTEM - Hydraulic schematic frame 01 (ISO-Pattern Pilot Controls)

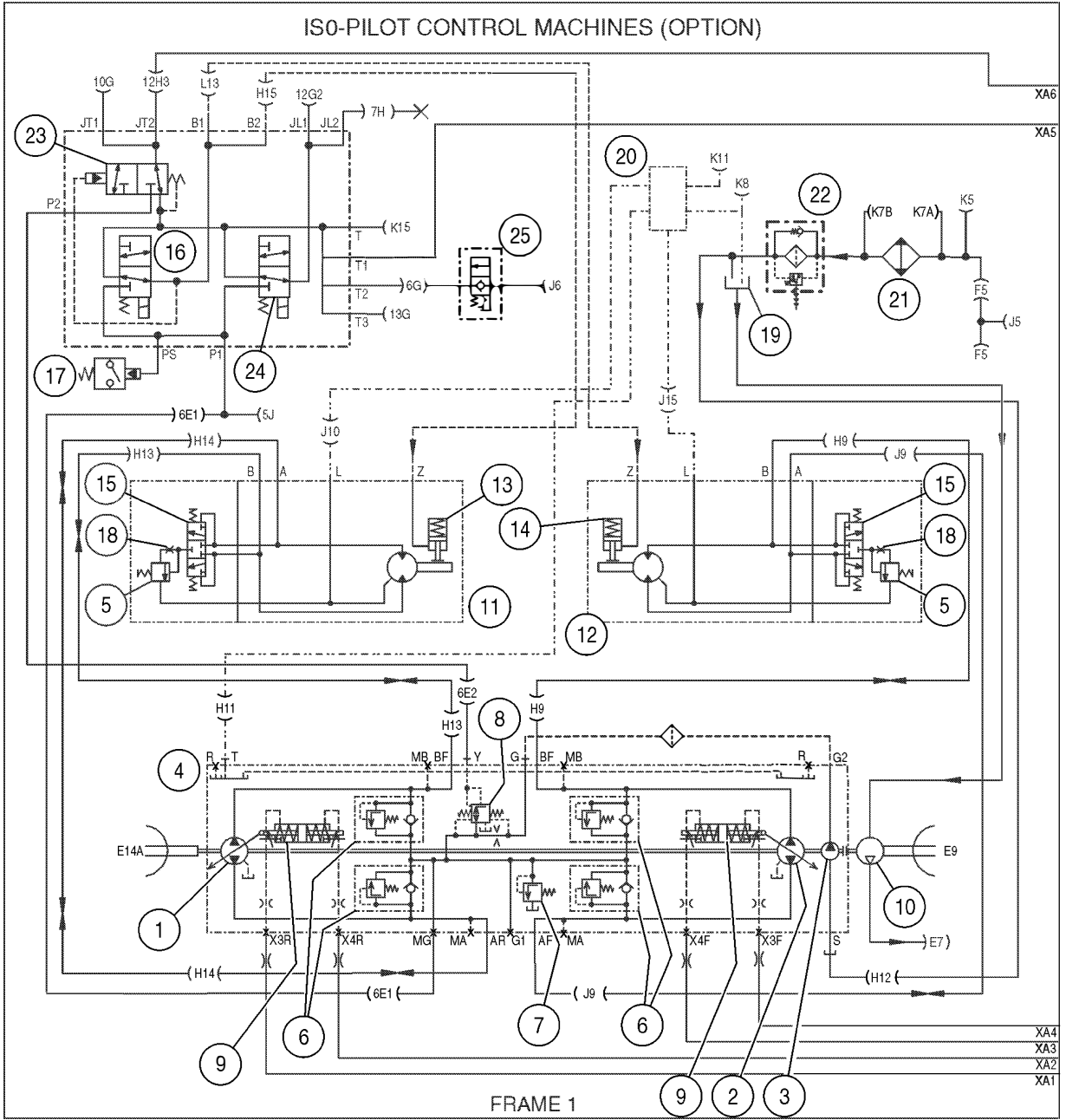

BC08A244-01A 1

BC08A244-01A

1. Left Piston Pump	10. Hydraulic Pump	19. Hydraulic Reservoir
2. Right Piston Pump	11. Left Drive Motor	20. Drain Manifold
3. Charge Pump	12. Right Drive Motor	21. Oil Cooler
4. Hydrostatic Pump	13. Left Brake	22. Oil Filter Bypass Valve
5. Circuit Relief Valve	14. Right Brake	23. Ground Drive Interlock
6. High Pressure Relief Valve	15. Flushing Valve	24. Loader Interlock
7. Control Cartridge	16. Brake Solenoid Valve	25. Manual Boom Lowering Valve
8. Boost Valve	17. Charge Pressure Switch	
9. Servo Piston	18. Shut-Off Plug	

This as a preview PDF file from best-manuals.com



Download full PDF manual at best-manuals.com