

WXI45 / WXI65 / WXI85 Wheeled Excavators Stage IIIA

WXI45
WXI65
WXI85

Wheeled Excavators Stage IIIA

Operator's Manual

Print No. 84285662
1st edition

English 01/10 ORIGINAL INSTRUCTIONS

CASE
CONSTRUCTION

CASE
CONSTRUCTION

WX145

WX165

WX185

Wheeled Excavators Stage IIIA

Operator's Manual

Print no. 84285662

1st Edition

English 01/10 ORIGINAL INSTRUCTIONS



SUMMARY OF SECTIONS

1 - INTRODUCTION, SAFETY, PLATES AND DECALS

2 - CONTROLS AND INSTRUMENTS

3 - OPERATING THE MACHINE

4 - SUPPLIES AND SERVICE CHART

5 - STORAGE

6 - ACCESSORIES

7 - DATA AND TECHNICAL SPECIFICATIONS

8 - ALPHABETICAL INDEX

ATTACHMENT 1 - "EC" DECLARATION OF CONFORMITY

INDEX

SECTION 1

INTRODUCTION, SAFETY, PLATES AND DECALS	1-1
FOREWORD.....	1-1
DESIGNATED USE	1-1
SAFETY INSTRUCTIONS.....	1-3
GENERAL SAFETY INSTRUCTIONS.....	1-3
DESIGNATED USE	1-4
NOISE LEVELS	1-5
LEVEL OF VIBRATIONS TRANSMITTED TO THE OPERATOR.....	1-6
BEFORE OPERATING THE MACHINE	1-7
OPERATING THE MACHINE	1-8
TRAVEL.....	1-10
TRAVELLING ON PUBLIC ROADS	1-11
JOB SITE OPERATION.....	1-14
PARKING THE MACHINE.....	1-15
LOADING THE MACHINE ON A TRAILER.....	1-16
MACHINE TRANSPORT	1-17
UNLOADING THE MACHINE FROM A TRAILER.....	1-18
MAINTENANCE AND ADJUSTMENTS.....	1-19
PREVENTION OF FIRE OR EXPLOSIONS.....	1-22
PREVENTION OF BURNS.....	1-23
PRECAUTIONS FOR WASTE DISPOSAL.....	1-24
MAIN COMPONENTS	1-25
PLACING BOOM ATTACHMENT.....	1-25
MONOBOOM ATTACHMENT	1-26
COMPONENTS IDENTIFICATION PLATES.....	1-29
MACHINE	1-29
ENGINE	1-29
CAB	1-30
PUMP	1-30
AXLES	1-30
CONTROL VALVE.....	1-31
DECALS.....	1-31
POSITION OF DECALS	1-32

SECTION 2

CONTROLS AND INSTRUMENTS	2-1
SWITCHES AND PUSH-BUTTONS.....	2-1
“BUZZER”: ACOUSTIC WARNING SIGNAL	2-7
CONTROLS AND PEDALS	2-8
MULTI-FUNCTION DISPLAY	2-11
OPERATING MODE	2-16
MAIN MENU	2-17
DISPLAY SETTING, MAIN MENU.....	2-18
CONTRAST	2-19
BRIGHTNESS	2-20

INDEX

TIME	2-21
UNITS	2-24
SYMBOLS	2-26
STARTER SWITCH	2-27
RADIO	2-29
CAB	2-30
ENTRY AND EXIT	2-30
DOOR OPENING	2-30
DOOR CLOSING	2-31
SIDE WINDOW	2-31
FRONT WINDOW	2-32
EMERGENCY EXIT	2-33
WINDSCREEN WIPER AND WASHER	2-33
FLOODLAMPS	2-34
DOCUMENTS STORAGE BOX, FIRST-AID KIT, WARNING TRIANGLE AND FIRE-EXTINGUISHER	2-35
SUNBLIND	2-35
CAB LIGHTING	2-36
AUXILIARY SOCKET	2-36
STEERING COLUMN	2-37
VENTILATION, HEATING AND AIR CONDITIONING (OPTIONAL)	2-38
VENTILATION (air from outside)	2-38
HEATING	2-40
AIR CONDITIONING (OPTIONAL)	2-41
SERVICE AND PARKING BRAKES	2-43
SERVICE BRAKE	2-43
PARKING BRAKE	2-44
OPERATOR'S SEAT	2-45
OPERATOR'S SEAT WITH PNEUMATIC SUSPENSION	2-45
SEAT BELT	2-49

SECTION 3

OPERATING THE MACHINE	3-1
GENERAL INSTRUCTIONS	3-1
BEFORE OPERATING THE MACHINE	3-1
OPERATING THE MACHINE	3-1
RUNNING-IN PERIOD	3-2
AFTER DAILY OPERATION - PARKING	3-3
START-UP	3-4
START-UP IMMOBILIZER	3-4
START-UP	3-9
ASSISTED STARTING (JUMP-STARTING)	3-11
ENGINE SHUT OFF	3-13
TRAVEL	3-14
BEFORE STARTING THE TRAVEL	3-14
BASIC POSITION	3-14
BASIC SETTING	3-16
TRAVEL	3-18
GEARBOX - GEAR CHANGE	3-21

TRAVEL WITH LOAD APPLIED TO CRANING HOOK.....	3-23
FLOATING AXLE BLOCKING AND UNBLOCKING.....	3-24
WORKING OPERATION.....	3-25
SAFETY INSTRUCTIONS.....	3-25
BEFORE BEGINNING THE WORK.....	3-26
HOLDING AND RELEASING THE UPPER STRUCTURE SLEW.....	3-31
POWER BOOST FUNCTION - POWER BOOST.....	3-37
LEVELLING MODE.....	3-39
HYDRAULIC DAMPING.....	3-41
STABILIZATION OF THE MACHINE.....	3-43
WORKING WITH STANDARD BUCKET OR CLAMSHELL.....	3-46
WORKING STAGES.....	3-48
OPERATING THE MACHINE WITH COLD WEATHER.....	3-51
COLD START - PREHEATING.....	3-52
OPERATING THE MACHINE WITH HOT WEATHER.....	3-54
MACHINE RECOVERY AND TOWING.....	3-55
SECURE THE MACHINE.....	3-56
WORKING ATTACHMENT.....	3-59
PLACING BOOM ATTACHMENT.....	3-59
WORKING ATTACHMENT WITH OFF-SET BOOM.....	3-62
BUCKET / CLAMSHELL.....	3-63

SECTION 4

SUPPLIES AND SERVICE CHART.....	4-1
SUPPLIES AND SERVICE CHART.....	4-1
FUEL.....	4-2
HYDRAULIC OIL.....	4-3
COOLANT.....	4-4
SAFETY INSTRUCTIONS.....	4-5
WORKING HOURS / INTERVALS.....	4-6
MAINTENANCE INTERVALS CHART.....	4-7
CHECKS BEFORE START-UP AND BEFORE EACH WORKING SHIFT (10 HOURS).....	4-10
MACHINE GENERAL INSPECTION.....	4-10
SERVICE BRAKE.....	4-11
PARKING BRAKE.....	4-11
UPPER STRUCTURE HOLDING BRAKE.....	4-12
LIGHTS.....	4-12
CONTROLS AND LAMPS OPERATION.....	4-12
ENGINE OIL - LEVEL.....	4-13
HYDRAULIC OIL TANK - LEVEL.....	4-13
FUEL TANK - LEVEL.....	4-15
COOLING SYSTEM LIQUID - LEVEL.....	4-16
SCREEN WASHER LIQUID - LEVEL.....	4-17
WORKING ATTACHMENT - GREASING.....	4-18
OFF-SET BOOM - GREASING.....	4-19
TYRES - PRESSURE CHECK.....	4-20
TYRES - NUTS TIGHTENING.....	4-22
WEEKLY SERVICE (50 HOURS).....	4-23
CAB AIR FILTER - CLEANING.....	4-23

INDEX

AIR FILTER - CLEANING	4-24
AIR INTAKE LINE - CHECK	4-26
MULTI-COOLER - CLEANING	4-26
FUEL SYSTEM - AIR BLEEDING AND WATER DRAINING	4-27
FUEL FILTER/S - WATER DRAINING	4-30
SLEWING GEARBOX - OIL LEVEL	4-31
BATTERIES - LEVEL - CHARGE CHECK AND CLAMPS TIGHTENING.....	4-32
SLEWING BEARING CUPS AND AXLE FLOATING PINS - GREASING.....	4-34
QUICK COUPLER MILLER VERSION -GREASING.....	4-35
QUICK COUPLER LEHNHOFF VERSION -GREASING	4-35
MONTHLY SERVICE (250 HOURS)	4-37
ENGINE OIL FILTER - CHANGE	4-37
HYDRAULIC OIL RETURN FILTER - CHANGE	4-39
STEERING AXLE - OIL LEVEL	4-40
TRAVEL GEARBOXES - OIL LEVEL	4-41
RIGID AXLE AND GEARBOX - OIL LEVEL	4-42
AIR CONDITIONING SYSTEM	4-43
BLADE AND STABILIZERS JOINTS, CARDAN SHAFT, STEERING TRUNNION PINS - GREASING.....	4-44
FLOATING AXLE LOCKING CYLINDERS CONTACT FACES - LUBRICATION	4-45
SERVICE EVERY 2 MONTHS (500 HOURS).....	4-46
FUEL FILTER- CHANGE.....	4-46
ENGINE REVOLUTIONS SENSOR - CLEANING	4-47
DRIVE BELTS - CHECK.....	4-48
ENGINE OIL - CHANGE.....	4-49
SLEWING BEARING - SCREW TIGHTENING CHECK.....	4-50
SLEWING BEARING TEETH - GREASING	4-51
SLEWING GEARBOX - SCREWS TIGHTENING CHECK.....	4-51
SERVICE AFTER 1000 HOURS	4-52
CAB AIR FILTER - CHANGE	4-52
WINDSCREEN BLADES - CHANGE	4-52
ENGINE BRACKETS - SCREWS TIGHTENING CHECK.....	4-53
ENGINE BELT TENSIONER - CHECK	4-53
AIR FILTER - REPLACEMENT OF MAIN FILTER ELEMENT AND OF SAFETY ELEMENT.....	4-54
HYDRAULIC SYSTEM BLEEDING VALVE - CHANGE.....	4-55
STEERING AXLE - OIL CHANGE.....	4-55
RIGID AXLE AND GEARBOX - OIL CHANGE.....	4-57
SERVICE BRAKE - PLATES CHECK	4-59
PILOT CONTROL FILTER - CHANGE	4-60
AIR CONDITIONING SYSTEM - CLEANING AND OPERATION CHECK - COMPRESSOR BELT CHANGE	4-60
SERVICE AFTER 3000 HOURS	4-64
HYDRAULIC OIL TANK - CLEANING AND OIL CHANGE	4-64
HYDRAULIC SYSTEM - AIR BLEEDING.....	4-66
ENGINE - CHECK AND ADJUSTMENT OF VALVES CLEARANCE	4-66
COOLING SYSTEM LIQUID - CHANGE.....	4-67
FUEL TANK - CLEANING	4-68
SLEWING GEARBOX - OIL CHANGE	4-69
SERVICE WHEN NECESSARY	4-70
TYRES - CHANGE	4-71

SERVICE BRAKE - AIR BLEEDING.....	4-73
STEERING ADJUSTMENT	4-73
AXLE FLOATING LOCKING CYLINDERS - AIR BLEEDING.....	4-74
FUSES - REPLACEMENT.....	4-75
BULBS - REPLACEMENT.....	4-78
BATTERIES - REPLACEMENT.....	4-82
BUCKETS TEETH - CHANGE.....	4-83

SECTION 5

STORAGE	5-1
MACHINE STORAGE.....	5-1
ENGINE STORAGE	5-1
BATTERIES STORAGE	5-2
RECOMMISSIONING THE MACHINE AFTER PROLONGED STORAGE.....	5-2
DECOMMISSIONING OF THE MACHINE	5-2

SECTION 6

ATTACHMENTS.....	6-1
HYDRAULIC HAMMER	6-1
HYDRAULIC HAMMER SELECTION.....	6-1
SAFETY INSTRUCTIONS.....	6-1
USE OF HYDRAULIC HAMMER.....	6-3
HYDRAULIC SHEARS	6-8
SELECTING THE HYDRAULIC SHEARS.....	6-8
SAFETY INSTRUCTIONS.....	6-8
USE OF HYDRAULIC SHEARS.....	6-9
HYDRAULIC QUICK COUPLER	6-13
SAFETY INSTRUCTIONS.....	6-13
QUICK ASSEMBLY AND DISASSEMBLY	6-15
HANDLING OF LOADS	6-17
CLAMSHELL BUCKET	6-18
SAFETY INSTRUCTIONS.....	6-18
CLAMSHELL BUCKET ASSEMBLY.....	6-18
CLAMSHELL BUCKET DISASSEMBLY.....	6-20
PARAMETERS SETTING	6-21
SWITCHING OVER FROM STANDARD TO CLAMSHELL BUCKET.....	6-21
ROTARY CUTTER	6-23
SAFETY INSTRUCTIONS.....	6-23
USE OF THE ROTARY CUTTER.....	6-24
CRANING HOOK.....	6-28
SAFETY INSTRUCTIONS.....	6-28
USE OF THE CRANING HOOK	6-28
OVERLOAD WARNING SYSTEM.....	6-29
BREAK PROTECTION VALVES	6-31
REAR FLOODLAMPS	6-32
ROTARY LIGHT	6-33
SINGLE LIGHT	6-33
DOUBLE LIGHT	6-33

INDEX

SWITCHING ON AND OFF	6-33
FUEL TRANSFER PUMP	6-34
FRONT CAB PROTECTION.....	6-36
BLADE PROTECTION.....	6-36
TRANSPORT BRACKET FOR CLAMSHELL.....	6-36
CENTRALIZED LUBRICATION.....	6-37
SAFETY INSTRUCTIONS.....	6-37
OPERATION.....	6-37

SECTION 7

DATA AND TECHNICAL SPECIFICATIONS	7-1
DIMENSIONS - OPERATING WEIGHTS	7-1
WX 145 MODELS.....	7-1
WX 165 MODELS.....	7-4
WX 185 MODELS.....	7-7
DIGGING PERFORMANCE	7-9
WX 145 MODELS.....	7-9
WX 165 MODELS.....	7-14
WX 185 MODELS.....	7-19
LIFTING CAPACITIES.....	7-23
HYDRAULIC SYSTEM	7-24
PUMPS	7-24
CYLINDERS (ø for stroke).....	7-24
SLEWING	7-24
TRAVEL.....	7-24
TYRES.....	7-25
BRAKES	7-25
STEERING.....	7-25
POWER STEERING.....	7-25
ELECTRICAL SYSTEM.....	7-26
BUCKETS.....	7-26
BUCKETS - WX 145.....	7-26
BUCKETS - WX 165.....	7-26
BUCKETS - WX 185.....	7-26
TIGHTENING TORQUES.....	7-27
FUEL SYSTEM.....	7-27
ENGINE	7-28

SECTION 8

ALPHABETICAL INDEX.....	8-1
--------------------------------	------------

ATTACHMENT 1 - "EC" DECLARATION OF CONFORMITY

SECTION 1

FOREWORD, SAFETY, PLATES AND DECALS

FOREWORD

The wheeled excavators WX145 - WX165 - WX185 are operation hydraulic machines.

They essentially consist in a wheeled undercarriage on which a slewing bearing is mounted, which is coupled to the upper frame.

The upper frame supports the front attachment, the engine, the hydraulic components, the cab, the fuel tank and the counterweight.

When the operator activates the controls (hydraulic control levers and pedals), the hydraulic pumps rotated by the engine suck oil from the tank and convey it to the control valve; the control valve, in turn, sends it to the relevant users.

A cooling system keeps the hydraulic fluid at a normal operating temperature.

DESIGNATED USE

The machine has been built in accordance with state-of-the-art standards and the recognized safety rules.

The machine must be used in accordance with its designated use, by observing the safety and precautionary rules and by strictly following the operating instructions. Any functional disorders, especially those affecting the safety of the machine, should therefore be rectified immediately.

The Excavator is intended to be used in digging and loading operation (with bucket or grab or clamshell bucket), ground levelling (with blade when installed) and use of hydraulic hammer to break concrete or other solid material.



A different use of the excavator or of its working equipment:

- for lifting or transporting persons;
- as a working platform;
- for lifting loads without the attachment being approved for this purpose;
- for pulling slung loads;
- for driving in posts, supports, sheet-piles, without the attachment being approved for this purpose;

is considered contrary to the designated use.

Improper use may cause injury or life-threatening risks for the operator and for other persons.

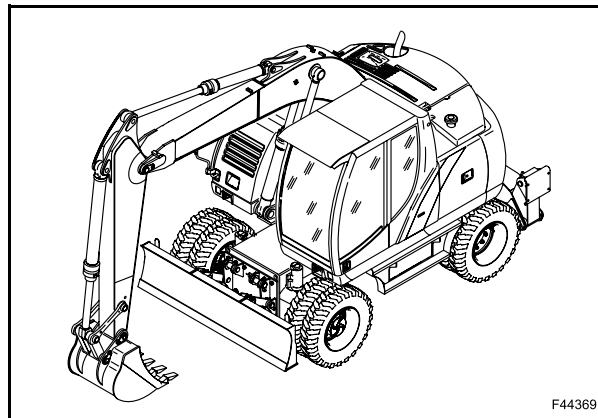

1

The manufacturer/supplier cannot be held responsible for any damage resulting from other than the designated use. The risk involved in such misuse lies entirely with the user.



For clarity purposes, some figures in this Manual show the machine with protection panels or covers removed. Never operate the machine with any protection panels or covers removed.



It is absolutely forbidden to tamper and/or change the setting of any of the hydraulic system valves to avoid damaging machine components with consequent risks to personal safety.

The current Operator's Manual is the user's guide for correct run-in, use and maintenance of the machine.

Carefully read this Operator's Manual and store it in the cab for quick location and reference.

Instructions concerning safety, operation and maintenance have been developed to permit safe service and operation of this machine.

In the event of queries or suggestions relevant to your machine do not hesitate to address to your Dealer. Dealers have qualified and trained personnel at disposal as well as Original Spares, means and equipment suitable to carry out all necessary maintenance.

Do not use this machine for any applications or purposes other than those described in this Manual. If you use this machine for duties involving the use of attachments, accessories, or special tools, consult your Dealer to make sure that the adaptations or modifications carried out are in conformity with the machine's technical specifications and with current regulations on safety.

Any modifications or adaptations which are not approved by the Manufacturer may invalidate the machine's original conformity with safety requirements.

IMPORTANT: *the engine and fuel system on your machine is designed and built to government emissions standards. Tampering by dealers, customers, operators and users is strictly prohibited by law. Failure to comply could result in government fines, rework charges, invalid warranty, legal action and possible confiscation of the machine until rework to original condition is completed. Engine service and/or repairs must be done by a certified technician only.*

Before entrusting this machine to an operator, make sure that:

- the operator is qualified to operate the machine correctly and safety;
- the operator has read and fully understood the instructions given in this Manual.

Consult your Dealer to obtain extra manuals or manuals in other languages.

Your Dealer is at your disposal for any further information.

SPARE PARTS

The "non-genuine" spare parts have not been controlled and authorized by the Manufacturer. The assembly and/or use of such products may have negative effects on the machine design features and could impair its operation safety. The Manufacturer is not liable for any damage caused by "non-genuine" spare parts or accessories.

WARRANTY

This machine is under warranty according to the regulations in force in Your Country and in compliance with the sales agreement drawn up with the Dealer. The warranty, however, expires if the operation and maintenance instruction for this machine and contained in this manual, have not been followed.

NOTE: *each machine is supplied complete with a copy of this Manual. Descriptions and illustrations herein are not binding. The Manufacturer, provided that the basic characteristics of machine types described and shown in this Manual remain the same, reserves the right to change components, parts and accessories supplied without any commitment to timely update this publication; and this any time it deems it convenient for improvement purposes or due to commercial or manufacturing requirements. For exact information, please consult your Dealer or contact the Manufacturer's Branch Offices.*

SAFETY INSTRUCTIONS

GENERAL SAFETY INSTRUCTIONS

Carefully read the safety rules contained herein and follow advised precautions to avoid potential hazards and to safeguard your safety and personal integrity.

In this manual you will find the following indications:

 **WARNING** 

This symbol warns about the possibility of potential damages to the machine that can involve the operator's safety.

 **DANGER** 

With specific warnings about potential dangers for the operator's or other persons integrity directly or indirectly involved.

The non compliance with the warning preceded by the above mentioned key-words (**WARNING** and **DANGER**) can cause serious accidents or even the death of the persons involved.

Moreover in the present Manual have been given some instructions with texts in italics, preceded by the words **NOTE** and **CAUTION**:

NOTE: *it emphasizes and underlines to the operator the correct technique or correct procedure to follow.*

 **CAUTION** 

It warns the operator of a possible hazard of machine damage in case he does not follow a determined procedure.

Your safety and that of people around you depends on you. It is essential that you understand this manual for the correct operation, inspection, lubrication and maintenance of this machine.

Pay particular attention to the "Fundamental safety instructions" and to all warnings and safety instructions attached to the machine.

Familiarize yourself with the machine operation and the operating patterns of the control elements prior to starting up the machine.

The operators must be fully informed about the operation and application of this or comparable machines.

The safety messages in this section concern situations which may arise during normal machine operation and maintenance. These safety messages also indicate the different ways of coping with these situations. Other safety messages are used throughout the manual to indicate specific dangers.

Always keep this manual in the storage compartment provided for it. Make sure that it is always complete and in good condition. Consult your Dealer to obtain extra manuals.

NOISE LEVELS

Sound power level (acoustic external)

LWA:

WX 145 models: 101 dB (A)

WX 165 models: 102 dB (A)

WX 185 models: 103 dB (A)

Sound power level guaranteed (1), determined in compliance with European standard 2000/14/EC.

Sound pressure level in the operator's seat (acoustic internal)

LpA:

WX 145 models: 76 dB (A)

WX 165 models: 77 dB (A)

WX 185 models: 78 dB (A)

Sound pressure level continuous, measured inside of cabin with door and windows closed and with the heater/air conditioner blower operating at 2nd speed, measured on an identical machine, in compliance with ISO 6396:2008 Standard.

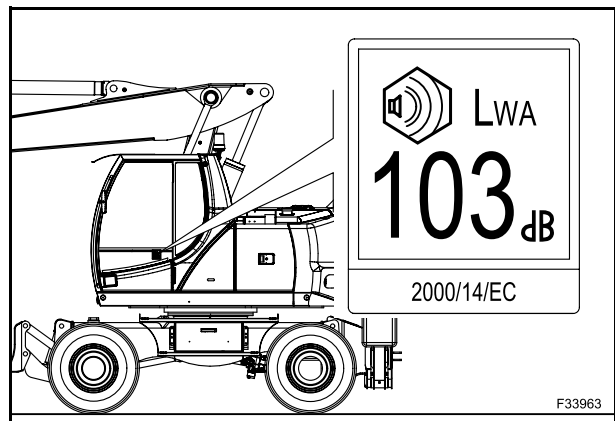

LEVEL OF VIBRATIONS TRANSMITTED TO THE OPERATOR

The vibration level transmitted to the operator depends mainly on the conditions of the soil where the machine is being operated and on the use conditions of the machine and its equipment.

The exposure to vibrations can be remarkably reduced if the recommendations here below are followed:

- use equipment suitable for the machine and the type of work to be carried out;
- adjust and lock the seat in the correct position; regularly check for the seat suspensions and carry out adjustments or maintenance as required;
- carry out regularly the ordinary maintenance of the machine at scheduled intervals;
- operate the attachment evenly, avoiding sudden motion or extreme shocks, if possible;
- as far as possible, avoid travelling on particularly uneven soils or the impact with possible obstacles.

This machine is equipped with an operator's seat which meets the criteria of EN ISO 7096:2008 representing vertical vibration input under severe but typical operating conditions.

This seat is tested with the input spectral class EM.6 and has a seat transmissibility factor SEAT < 0.7.

The intent is to limit the operator's exposure to vibrations.

The exposure is dependant on machine operating techniques and can be controlled by following the instructions described in this manual.

The weighted average acceleration value to which the operator's arms are subjected does not exceed 2.5 m/s² (8.20 ft/s²).

The weighted average acceleration value to which the operator's body is subjected does not exceed 0.5 m/s² (1.64 ft/s²).

These results have been obtained by using an acceleration gauge during the ditches excavation works.

NOTE: the Whole-body exposure value is determined under particular operating and terrain conditions and therefore may not be representative of all the possible operating conditions within the intended use of the machine. Consequently this single vibration emission value is not intended to determine the whole-body vibration exposure as required by European Directive 2002/44/EC. For this purpose it is recommended to conduct actual working condition measurement. If this is not feasible use of information provided in the table below, from ISO/TR 25398:2006 (*), is suggested.

Operating condition	Average			Standard deviation (s)		
	1.4*a _{w,eqx} m/s ² (ft/s ²)	1,4* _{aw,eqy} m/s ² (ft/s ²)	a _{w,eqz} m/s ² (ft/s ²)	1.4*S _x m/s ² (ft/s ²)	1.4*S _y m/s ² (ft/s ²)	S _z m/s ² (ft/s ²)
Excavating	0.52 (1.70)	0.35 (1.14)	0.29 (0.95)	0.26 (0.85)	0.22 (0.72)	0.13 (0.42)
Transfer	0.41 (1.34)	0.53 (1.74)	0.61 (2.00)	0.12 (0.40)	0.20 (0.65)	0.19 (0.62)

(*) ISO/TR 25398:2006 Mechanical vibration - Guideline for the assessment of exposure to whole-body vibration of ride on operated earth-moving machines - Using harmonized data measured by international institutes, organizations and manufacturers.

OPERATOR PROTECTIVE STRUCTURE

— **⚠ WARNING ⚠** —

Your machine is equipped with an operator Protective Structure, such as: a Rollover Protective Structure (ROPS) and Falling Object Protective Structure (FOPS).

The Protective Structure is a special safety component of your machine.

DO NOT attach any device to the Protective Structure for pulling purposes. DO NOT drill holes to the Protective Structure.

The Protective Structure and interconnecting components are a certified system. Any damage, fire, corrosion or modification will weaken the structure and reduce your protection. If this occurs, the Protective Structure **MUST** be replaced so that it will provide the same protection as a new Protective Structure. Contact your dealer for Protective Structure inspection and replacement.

After an accident or fire that involve the cab and/or machine tip or roll over, the following **MUST** be performed by a qualified technician before returning the machine to field or job site operation:

- the Protective Structure **MUST** be checked and replaced if necessary;
- the mounting for the Protective Structure, operator seat and seat belt, **MUST** be carefully inspected for damages and replaced if necessary;
- all damaged parts **MUST** be replaced.

NOTE: do not weld, drill holes, attempt to straighten or repair the protective structure. Modification in any way can reduce the structural integrity of the structure which could cause death or serious injury in the event of fire, tip, rollover, collision or accident.



3

BEFORE OPERATING THE MACHINE

Read and assimilate the instructions and warnings shown in this manual before operating the machine.

The presence of grease, oil, mud or (in winter) ice on the steps and access handles can cause accidents. Make sure they are always clean.

Remove anything which might hinder visibility. Clean the windshield, windows and rear view mirrors.

Before travelling or working at night, check that the lighting and signalling systems are operating correctly.

Make sure the doors and the engine guard are correctly fastened before undertaking any travel.

Make sure that no loose object or tool is left on the machine or in the operator's compartment.

⚠ DANGER ⚠

The operator should be the only person on the machine. Make sure there is nobody on or near the machine.

When mounting or dismounting from the machine always face the machine and use the steps and access handles on the left-hand side of the machine.

Wear close fitting clothing and safety equipment appropriate for the job.

It is necessary to have at disposal:

- safety helmet;
- safety shoes;
- safety goggles, or face shield;
- heavy gloves;
- hearing protection;
- reflective clothing;
- wet weather clothing;
- respirator or filter mask.

Wear close fitting clothing and safety equipment appropriate for the job. Do not leave anything to the case. Avoid wearing loose clothing, jewellery, or other items that can catch on control levers or other parts of the machine.

To operate the machine in full safety, the operator should be completely careful. Do not wear radio or music headphones while operating machine.

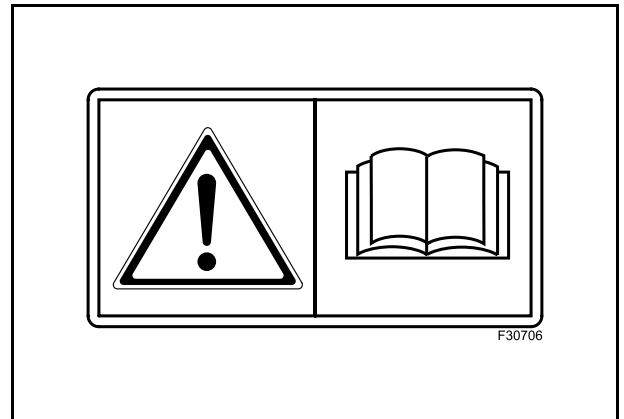

4

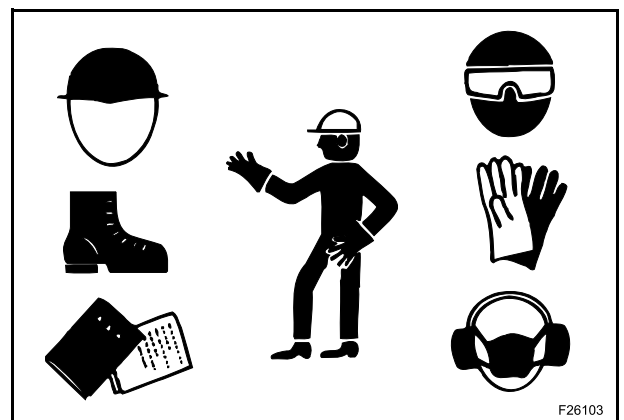

5

OPERATING THE MACHINE

USE HANDHOLDS AND STEPS

When you get on and off the machine, always maintain a three-point contact with the steps and handrails and face the machine.

Do not use any controls as hand-holds.

Never jump on or off the machine.

Never enter a moving machine.

Be careful of slippery conditions on platforms, steps, and handrails when leaving the machine.

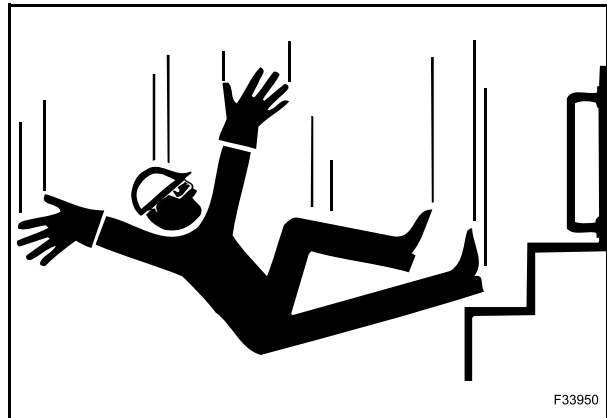

6

ADJUST SEAT AND SEAT BELT

A seat poorly adjusted for operator or work requirements may quickly fatigue the operator leading to improper operations.

The seat should be adjusted whenever another operates machine.

The operator should be able to fully press the pedals and correctly move the control levers with his back resting against the seat back.

If not, move the seat fore and/or aft, up and/or down and check again.



7

On machines with a seat belt for operator's safety:

- check the seat belt attached to the operator's seat. In the event of damage or after an accident, have it replaced immediately;
- fasten seat belt before starting to work.

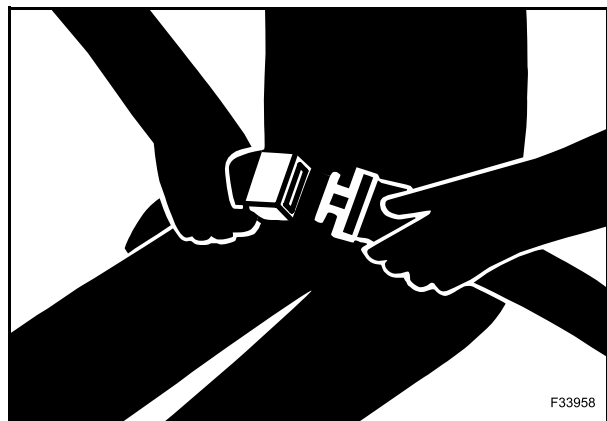

8

DON'T CARRY RIDERS ON THE MACHINE

Only machine operator is allowed on the machine. Riders are not allowed.

AVOID INJURY FROM REVERSE TRAVEL AND SWING ACCIDENTS

To avoid accidents due to swinging or reverse travel check the area around the machine. Before reverse travel or swinging the machine, make sure that nobody is present within its working reach. Use horn or other signals to warn bystanders before starting machine.

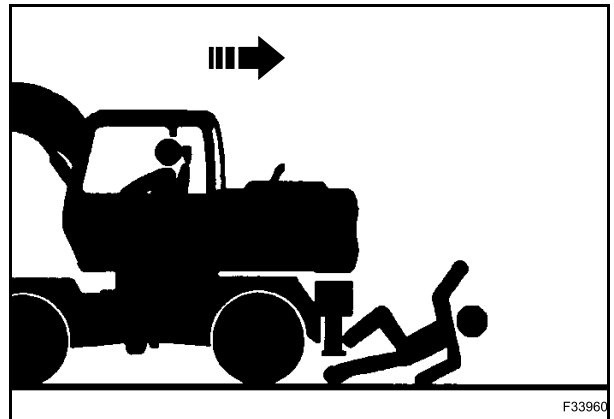

9

Take advantage of a person that watches the reverse travel if visibility is hindered. Always keep signalling person in view.

Use manual signals, according to local rules, if working condition require a flagman.

No motions shall be made unless signals are clearly understood by both signalman and operator.

Learn the meaning of all flags, signs, and markings used on the job and confirm who has the responsibility for signalling.

Keep windows, mirrors, and lights clean and in good condition.



10

Adjust the position of the rearview mirrors so that the side areas and the rear area are completely visible as shown in the figure.

NOTE: the picture aside also shows the visible zones according to the rearview mirrors so that their correct adjustment is intuitive.

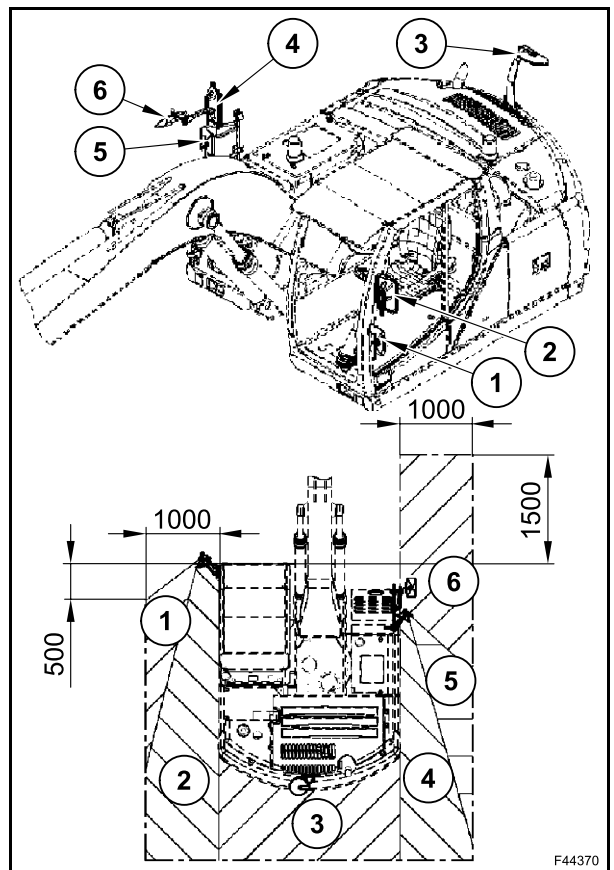

11

TRAVEL

MACHINE SIDES

The terms “right”, “left”, “front” and “rear”, when used in this manual, indicate the sides of the machine as seen from the operator’s seat.

1. Front side - forward
2. Rear side - backward
3. Right side
4. Left side

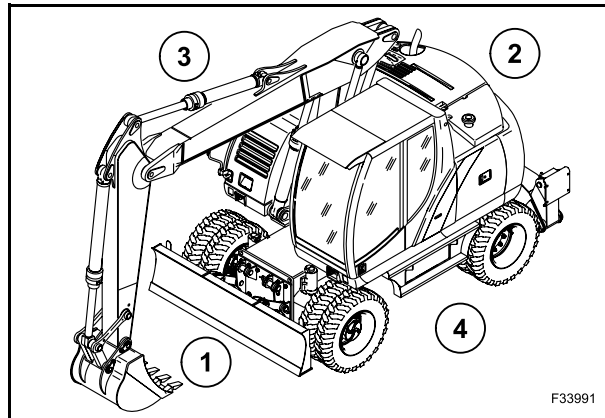

12

BEFORE SETTING OFF

Remove any soil, mud, snow, ice, grease and oil from your working footwear before operating the machine. You might otherwise slip from steps and pedals and thus initiate inadvertent movements.

Warn persons in the immediate vicinity by sounding the horn before setting off.

TRAVELLING OVER LONG DISTANCES OFF ROAD

Before travelling over long distances:

- return the front attachment in the travel direction;
- activate the upper structure holding brake in locked mode.

TRAVELLING ON SLOPES

Never drive across slopes or turn the machine on a slope.

The machine may slip or overturn.

Take special care on slippery soils.

Ensure that the tyres offer adequate grip. Only then are the steering and braking properties of the machine maintained.

TAKING A BEND

Reduce the machine speed while taking a bend. If the speed is too high and the steering wheel is wrenched round, there is a risk of the machine overturning (due to a wheel of the rigid axle being lifted off the ground). Extremely hard braking while taking a bend may also cause the machine to overturn.

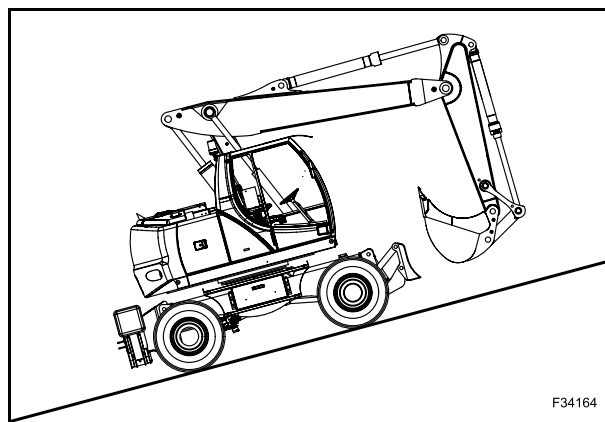

13

TRAVELLING ON PUBLIC ROADS



Road circulation (on public roads) is ruled by special provisions varying from country to country. Check beforehand with local authorities for circulation provisions.

Transfer on public roads (each time you leave a yard) is allowed only with an approved configuration, complying with dimensions (A), (B) as shown on the tables.

WX 145					
MONOBOOM					
Dipper	mm (in)	2600 (102.36)	2300 (90.55)	2000 (78.73)	
A	Maximum height	mm (in)	3930 (154.72)	3870 (152.36)	3915 (154.13)
B	Frontal off-set	mm (in)	4080 (160.62)	4095 (161.22)	4080 (160.62)
PLACING BOOM					
Dipper	mm (in)	2600 (102.36)	2300 (90.55)	2000 (78.73)	
A	Maximum height	mm (in)	4000 (157.48)	3955 (155.70)	3950 (155.51)
B	Frontal off-set	mm (in)	2685 (105.70)	2750 (108.26)	2910 (114.56)
OFF-SET BOOM					
Dipper	mm (in)	2000 (78.73)			
A	Maximum height	mm (in)	4000 (157.48)		
B	Frontal off-set	mm (in)	4130 (162.59)		
WX 165					
MONOBOOM					
Dipper	mm (in)	2900 (114.17)	2600 (102.36)	2300 (90.55)	
A	Maximum height	mm (in)	3980 (156.69)	3965 (156.10)	3965 (156.10)
B	Frontal off-set	mm (in)	4200 (165.35)	4215 (165.94)	4225 (166.33)
PLACING BOOM					
Dipper	mm (in)	2600 (102.36)	2300 (90.55)	-	
A	Maximum height	mm (in)	3925 (154.52)	3925 (154.52)	-
B	Frontal off-set	mm (in)	2605 (102.55)	2680 (105.51)	-
OFF-SET BOOM					
Dipper	mm (in)	2000 (78.73)			
A	Maximum height	mm (in)	4000 (157.48)		
B	Frontal off-set	mm (in)	4130 (162.59)		

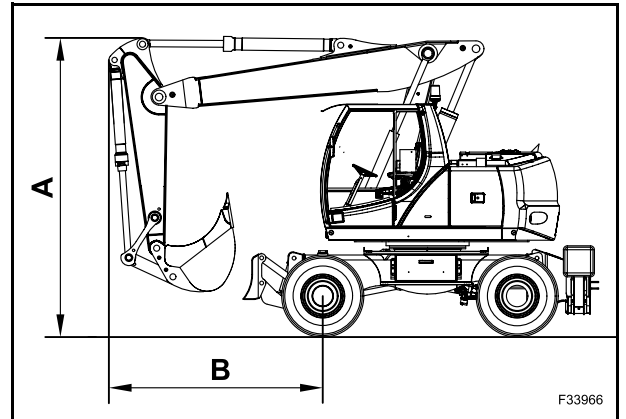

14

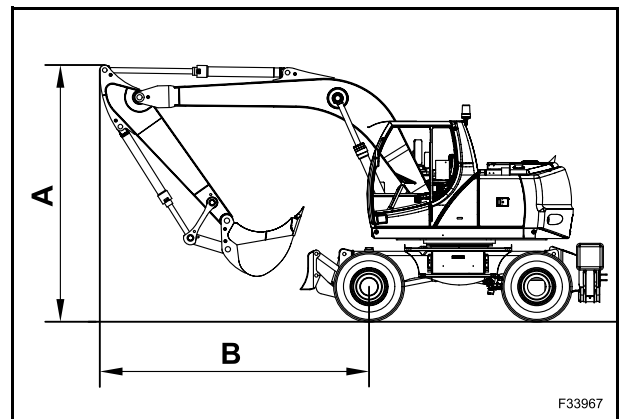

15

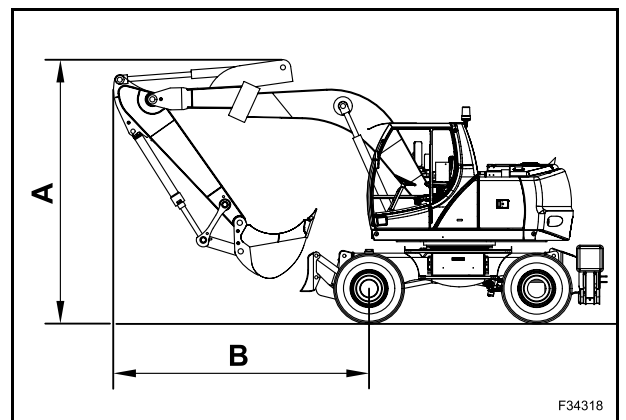

16

WX 185					
MONOBOOM					
Dipper	mm (in)	2800 (110.24)	2400 (94.98)	2000 (78.73)	
A	Maximum height	mm (in)	3850 (151.57)	3800 (149.60)	3800 (149.60)
B	Frontal off-set	mm (in)	4750 (187.00)	4750 (187.00)	4850 (190.94)
PLACING BOOM					
Dipper	mm (in)	2400 (94.98)	2000 (78.73)	-	
A	Maximum height	mm (in)	4000 (157.48)	4000 (157.48)	-
B	Frontal off-set	mm (in)	2800 (110.24)	2750 (108.26)	-

WARNING

During road transfer with monoboom version the help of a flagman to signal the motion is compulsory.

Car with blinking lights and flags should precede and follow the machine.

WARNING

ITALY ROAD TRAVEL APPROVAL: travel with traffic beams and rotary light alight (also during the day). If the machine is equipped with off-set boom, it is not approved for road travel.

GERMANY ROAD TRAVEL APPROVAL: travel with traffic beams alight (also during the day). If the machine is equipped with off-set boom, it is not approved for road travel.

WARNING

If the machine is equipped with off-set boom, to travel on public highways, address each time the pertinent authorities and respect the rules in force relevant to circulation.

MACHINE LAY-OUT

- Assemble the overall lights on the dipper.
- Connect the overall lights to outer socket, installed on the frame.
- Raise the stabilizer blade completely.
- Attach the reflective strips on the stabilizer blade.
- Raise the stabilizers completely (optional). They have to stay in vertical position.
- Switch off the working floodlamps.
- Lock the upper structure by means of undercarriage.
- Activate the "Road travel" mode (1).

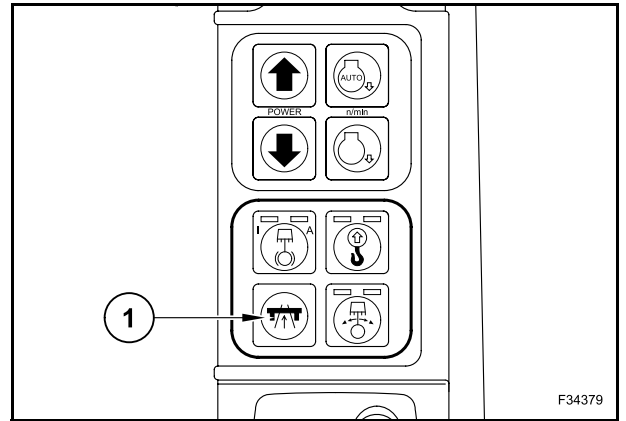

17

- On machines equipped with clamshell.
- The clamshell switching over valve has to be set to "clamshell" position. In this way, the bucket cylinder is hydraulically locked. Install the safety pin (2).
- Position the clamshell into the suitable support (3) of the undercarriage.

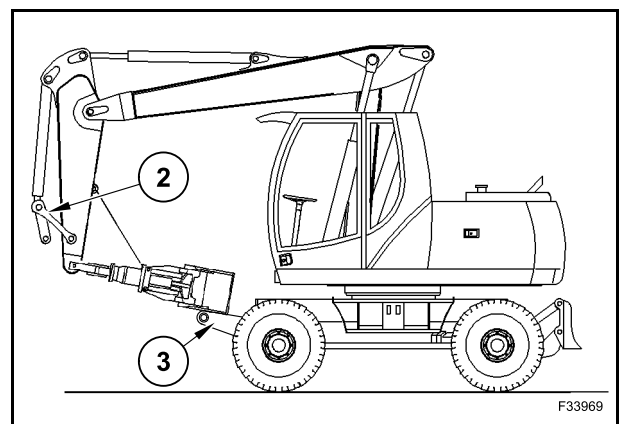

18

TRAVELLING UPHILL AND DOWNHILL

- During long tracks with remarkable gradient and at too high speed, you could loose control over the machine.
- Never travel tracks with a gradient higher than 30° (57.7%).
- Never travel on a long downhill tracks with the service brake engaged. This may cause an extreme wear of the brake plates or the brake's breakage.
- Before travelling downhill or uphill, to prevent the travel speed from becoming too fast, engage the 1st gear. With remarkable gradients, engage the creep speed.
- Do not travel across slopes or reverse the machine across slopes as it could overturn.

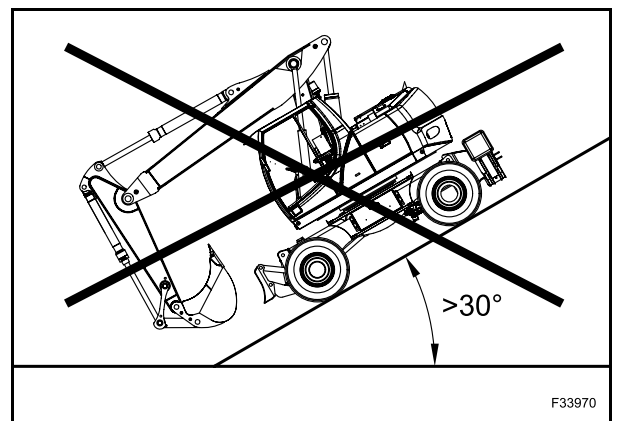

19

⚠ WARNING ⚠

Do not use the engine if the gradient is higher than 35°, as lubrication would be discontinuous, with consequent damage and wear.

JOB SITE OPERATION

INSPECT THE JOB SITE

Warn persons in the immediate vicinity by sounding the horn before starting work. Stop working if anyone is staying in the hazard range of the machine.

Work with the machine only when it is standing on a level ground.

Make sure the machine is standing always in a stable position during operation.

Make sure the working ground has sufficient strength to firmly support the machine.

When digging deeply, avoid hitting bottom of boom or bucket cylinder hoses against the ground. Use the bucket only for digging. To avoid accidents, do not use it as a jack hammer or wrecking ball.

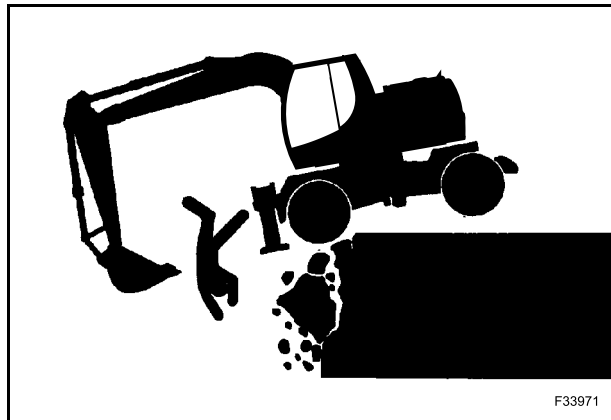

F33971

20

DIG WITH CAUTION

Accidental severing of underground cables or gas lines may cause an explosion and/or fire, possibly resulting in serious injury or death. Before digging, check the location of cables, gas lines, and water lines. Keep the minimum distance required by law from cables, gas lines, or water lines. In addition to general working safety instructions please consider: if a fibre optic cable should be accidentally severed, do not look into the end, to avoid eyes injury. If in doubt, contact local authorities and/or the distributing companies (Electric Power, Gas, Telephone, Water, Telecommunications, etc.). Ask for information about underground utility lines.

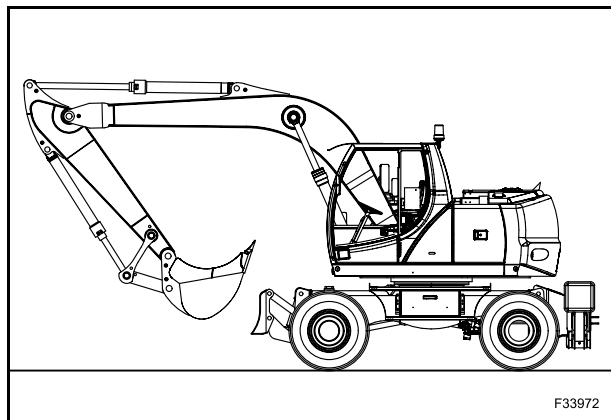

F33972

21

AVOID ELECTRIC LINES

Serious injury or death can result if the machine or front attachments are not kept a safe distance from electric lines. When operating near an electric line, never move any part of the machine or load closer than 3 m (9.84 ft) plus twice the line insulators' length (L). Check and comply with any local regulations that may apply. Ground dampness increases the area on which people might be affected by electric shocks.

Do not leave the machine until the damaged line is safely de-energized. Drive the machine out of the hazard zone, warn others against approaching and touching the machine, have the live wire de-energized.

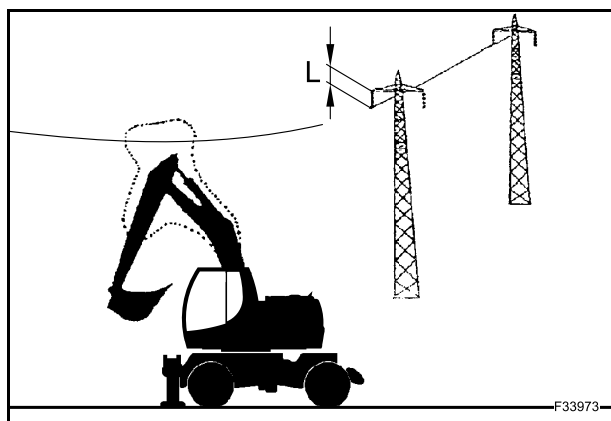

F33973

22

BEWARE OF EXHAUST FUMES

Engine exhaust fumes can cause sickness or death. If you must operate in closed buildings, be sure there is adequate ventilation.

Use an extension to eliminate exhaust gases or open doors and windows to ensure a sufficient air exchange.

PARKING THE MACHINE

- Park machine on flat and firm surface.
- Return the machine to basic position.
- Lock the upper structure.
- Place the attachment down on the ground.
- Engage the parking brake.
- Shut off the engine.



Do not shut off the engine when running at full speed, but let it run idle for some minutes to cool it down.

- Place chocks under the wheels.
- Set ignition key (1) to position "0" and pull it out.
- To allow all cylinders to release pressure set the starter switch key again to position "1" move both hydraulic control levers (2) and the pedal (3) in all directions.
- Ignition key (1) is set to "P". With key in this position, some electrical users are still under voltage, also with engine shut off.
- If these users remain under voltage for a long time, the batteries may discharge and prevent a engine start-up.
- Because of this, pay attention that the ignition key is always set to position "0", before leaving the machine parked for long time (for instance at work shift end).
- Disconnect the pilot control.
- Lift the left console and set the safety lever to the locked position.
- Close the window, the sliding roof and the cab door.
- Lock all doors and compartments of the machine.

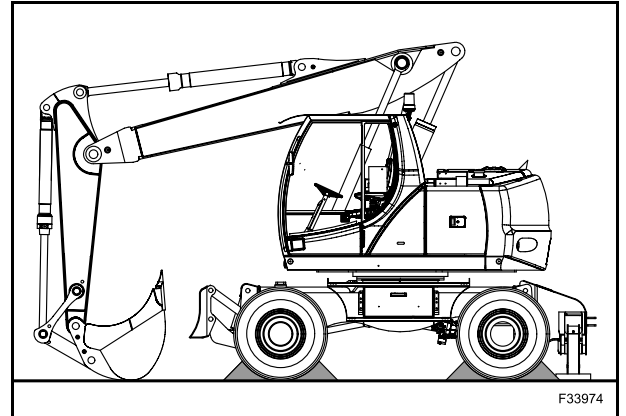

23

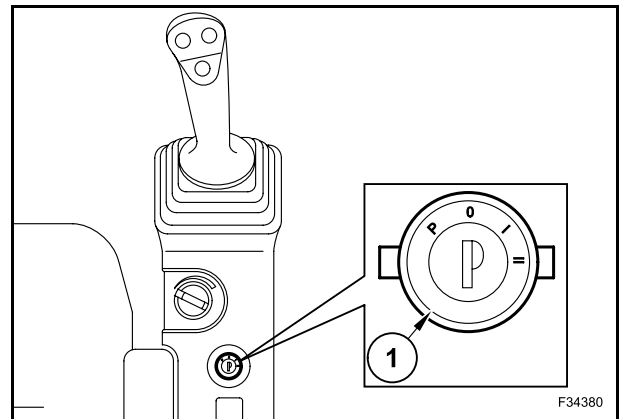

24

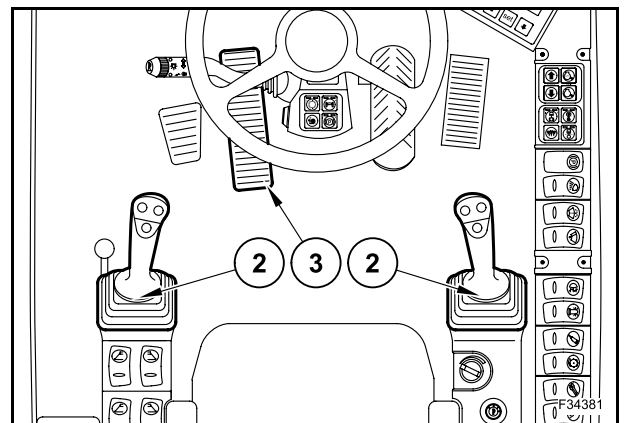

25

LOADING THE MACHINE ON A TRAILER

WITH FRONT ATTACHMENT INSTALLED

Travel forward along the ramp with the front attachment at the front.

Once the ramp top has been reached, and before the machine starts falling forward onto the flatbed (shifting its centre of gravity), rest the bucket flat onto the trailer flatbed (the angle between the booms should be 90° to 110°).

Travel slowly forward until the wheels are correctly positioned on the trailer flatbed.

Slightly raise the bucket from the flatbed, retract the dipper and keeping it tucked under, slowly swing the upper structure of 180° .

Retract the bucket and rest it on proper blocks (e.g.: wooden blocks).

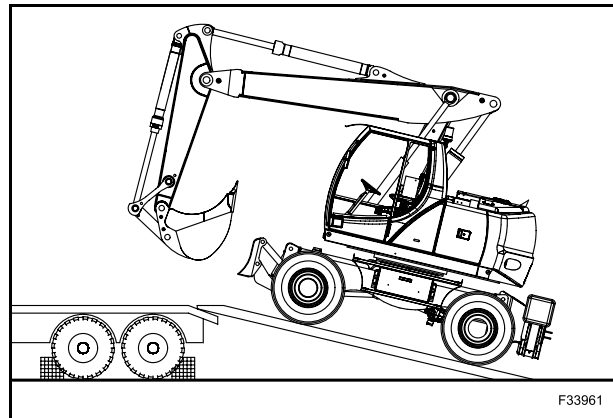

26

WITHOUT FRONT ATTACHMENT

Travel in reverse along the ramp as shown.

Machine centre of gravity should correspond to the trailer centre of gravity.

Stop the engine and pull out the ignition key.

Cycle the hydraulic control levers to relieve any residual hydraulic pressure from the booms driving cylinders.

Move the safety lever to end of travel to the vertical lock position.

Close all windows, front windscreens, and cab door. Cover the exhaust pipe to prevent water or dirt from entering.

Secure the machine to the trailer correctly, so as to prevent dangerous movements, proceed as follows:

- lock the machine frame to the trailer flatbed by means of chains or metal cables of suitable size, avoid to involve metal cables or chains and paneling;
- lock wheels by placing wedges (chocks) under them;
- lock the front attachment (if installed) to the flatbed using chains or metal cables of suitable size.

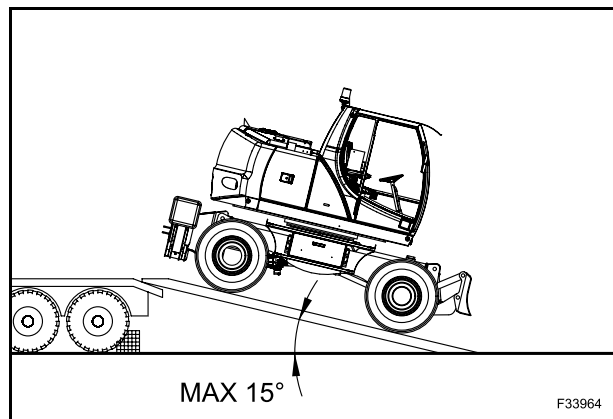

27

MACHINE TRANSPORT

In case of transport on public roads, ask for relevant permissions to competent authorities.

In case of transport by railway, ask for permission and agree the loading and transport of the excavator with the competent railway authorities.

According to the trailer or railway wagon width, disassemble completely or partially the working attachment. Loading dimensions and weights have to be determined from section 8 "data and technical specifications".

Pay the outmost attention while loading the machine on the trailer.

Enlist the help of someone.

Secure the machine from accidental movements.

Activate the parking brake by using the button (2).

Lock the upper structure by means of proper pin (3).

Lay the working attachment on the flatbed of the transporting vehicle.

Disconnect the pilot control with lever (1).

Shut off the engine.

In this way the upper structure holding brake engages automatically.

Remove the ignition key from the cylinder.

Close door and windows.

Place the chocks in front of the wheels.

Secure the machine properly, by anchoring chains to the points indicated on the machine by means of decals (4).

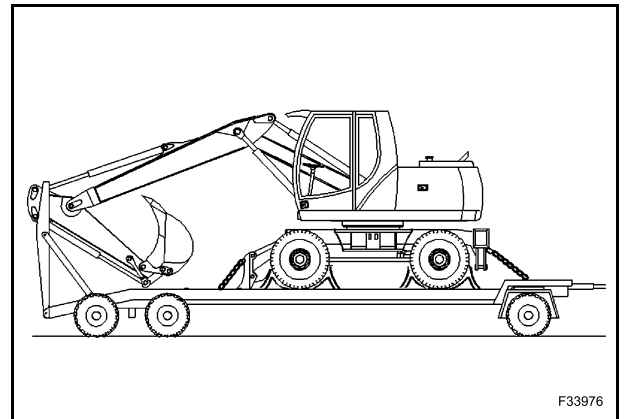

28

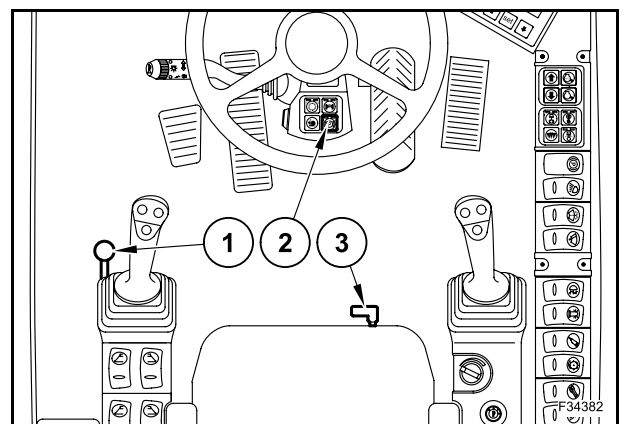

29

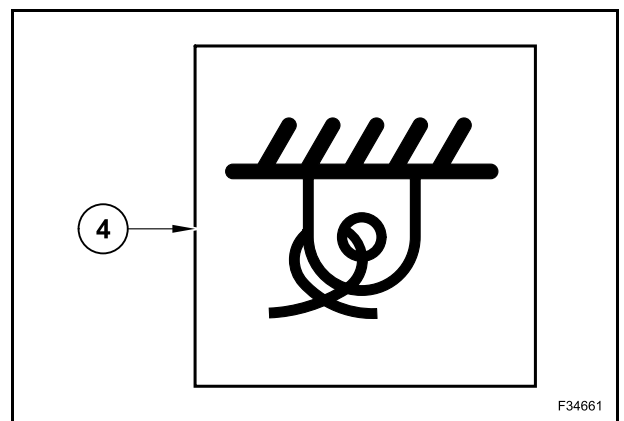

30

⚠ CAUTION ⚠

Do not insert the chains in the steering cylinders or in the hydraulic hoses of the brake.

UNLOADING THE MACHINE FROM A TRAILER

Unloading procedure may vary dependent upon whether the front attachment is installed or not.

WITH FRONT ATTACHMENT INSTALLED

Travel slowly in reverse along the flatbed.

Once at the flatbed end and before the machine starts falling forward onto the ramp (shifting the position of its centre of gravity), rest the bucket flat side onto the ground (the angle between the booms should be 90° to 110°).

Drive slowly forward while retracting the boom, extending the arm and repositioning the bucket resting onto the ground until the entire machine is unloaded.

IMPORTANT: to avoid damaging the front attachment, observe the following while unloading the machine:

minimum angle between boom and arm should never be lower than 90° and the bucket should never suddenly hit the ground.

WITHOUT FRONT ATTACHMENT

Travel forward down the ramp.

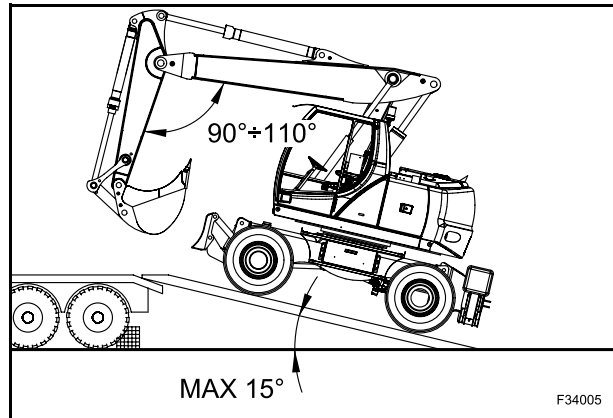

31

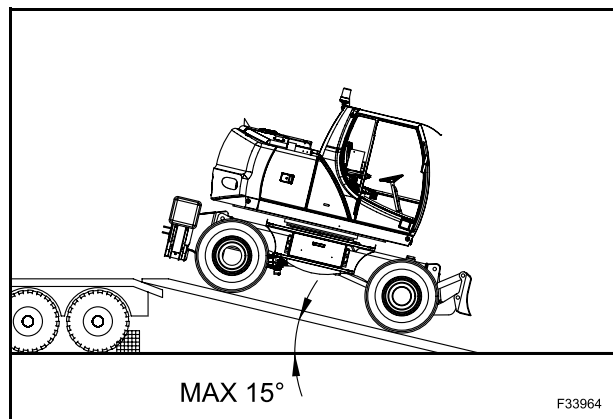

32

MAINTENANCE AND ADJUSTMENTS

Do not carry out any service operation until you have read and understood the instructions and warnings given in this manual.

Observe the adjusting, maintenance and inspection activities and intervals set out in the operating instructions, including information on the replacement of parts and equipment as this service concerns exclusively the qualified personnel.

Wear safety equipment and suitable clothing to perform the machine maintenance.

During the service work apply a warning plate.

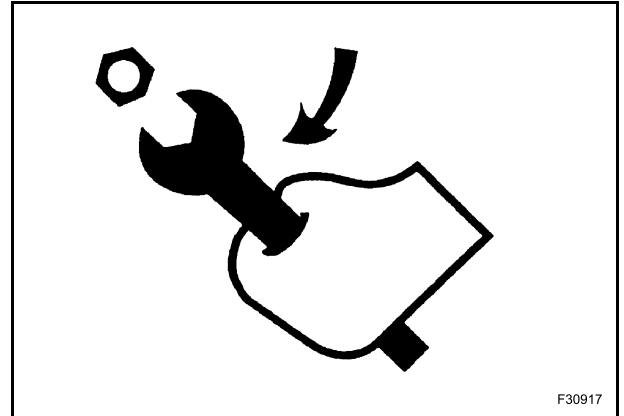

33

Always wear eye protection when using a tool which might project metal particles. Use a hammer with a soft face, such as copper, for installing pins.

Incorrectly performed maintenance or adjustments can cause serious injury. If you do not understand a maintenance or adjustment procedure, consult your Dealer.

If the attachment is raised or the machine moves with no operator on board, serious injury can result.

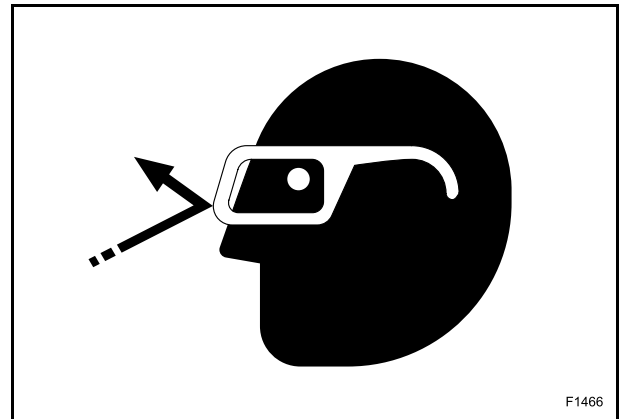

34

PRACTICE SAFE MAINTENANCE

Understand service procedures before doing work.

Keep work area clean and dry.

Never lubricate or service the machine while it is moving.

Keep hands, feet and clothing from power-driven parts.

Before carrying out any maintenance operation park the machine safely on a flat surface.

If maintenance procedure must be performed with engine running, do not leave machine unattended.



35

PROTECT AGAINST NOISE

PREPARE FOR EMERGENCIES

Prolonged exposure to loud noise can cause impairment or loss of hearing.

Wear a suitable hearing protective device such as earmuffs or earplugs to protect against constant or uncomfortably loud noise.

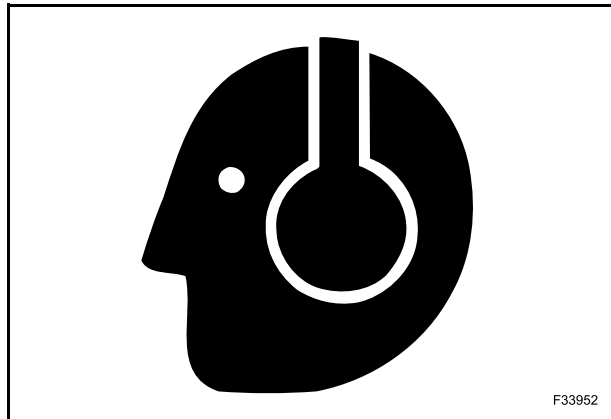

F33952

36

AVOID HIGH PRESSURE FLUIDS

Escaping fluid under pressure can penetrate the skin causing serious injury. Avoid this hazard by relieving pressure before disconnecting hydraulic or other lines.

Relieve the pressure by moving the hydraulic control levers several times. Tighten all connections before applying pressure. To protect the eyes wear a facial shield or safety goggles.

Search for leaks with a piece of cardboard; protect hands and body from high-pressure fluids.

If an accident occurs, see a doctor familiar with this type of injury immediately.

Any fluid penetrating the skin must be removed within few hours to avoid serious infections.

Hydraulic fluid or grease under pressure which penetrates the skin can cause serious injury. Take the necessary safety precautions (protective clothing and face and hand protection) to prevent all such risks. In addition, before handling these products, read the manufacturer's specific instructions for their use.

When carrying out a welding operation on the machine, as authorized by the Manufacturer and in accordance with his specifications, disconnect the alternator plug and connect the welding set earth lead to the component on which the welding is to be carried out. Never connect the earth lead to a hydraulic system component.

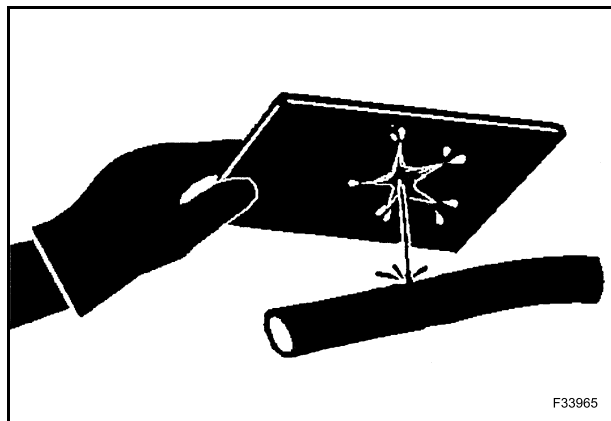

F33965

37



F33953

38



F33959

Escaping oil pollutes the environment. Have leaks repaired immediately.

Discard oil, rags or dirty paper in a proper way.

This as a preview PDF file from best-manuals.com



Download full PDF manual at best-manuals.com