



HYUNDAI
CONSTRUCTION EQUIPMENT

Robex 235LCR-9

CRAWLER EXCAVATOR



SERVICE MANUAL

TABLE OF CONTENT

- FOREWORD 8**
 - 1. Structure 8
 - 2. How To Read The Service Manual 9
 - 3. Conversion Table 10
- SECTION 1 GENERAL 16**
 - Group 1 Safety 17
 - Group 2 Specifications 26
 - 1. Major Component 26
 - 2. Specifications 27
 - 3. Working Range 28
 - 4. Weight 29
 - 5. Lifting Capacities. 30
 - 6. Bucket Selection Guide 32
 - 7. Undercarriage 34
 - 8. Specifications For Major Components. 36
 - 9. Recommended Oils 39
- SECTION 2 STRUCTURE AND FUNCTION 40**
 - Group 1 Pump Device 41
 - 1. Structure 41
 - 2. Function 47
 - Group 2 Main Control Valve 60
 - 1. Structure 60
 - 2. Hydraulic Circuit 63
 - 3. Function 64
 - Group 3 Swing Device 87
 - 1. Structure 87
 - 2. Principle Of Driving. 90
 - Group 4 Travel Device 98
 - 1. Structure 98
 - 2. Principle Of Driving. 100
 - Group 5 Rcv Lever 106
 - 1. Structure 106
 - 2. Functions 109
 - Group 6 Rcv Pedal 113
 - 1. Structure 113
 - 2. Function 115
- SECTION 3 HYDRAULIC SYSTEM 119**
 - Group 1 Hydraulic Circuit. 120
 - Group 2 Main Circuit 121
 - 1. Suction And Delivery Circuit 121

2. Return Circuit	122
3. Drain Circuit	123
Group 3 Pilot Circuit	124
1. Suction, Delivery And Return Circuit	125
2. Safety Valve (safety Lever)	126
3. Boom Priority System.	127
4. Travel Speed Control System	128
5. Main Relief Pressure Change System.	129
6. Arm Regeneration Cut System.	130
7. Swing Parking Brake Release	131
6. Bucket Out Operation.	132
7. Swing Operation	133
8. Travel Forward And Reverse Operation	135
Group 4 Single Operation	137
1. Boom Up Operation.	137
2. Boom Down Operation	138
3. Arm In Operation.	139
4. Arm Out Operation	140
5. Bucket In Operation	141
6. Bucket Out Operation.	142
7. Swing Operation	143
8. Travel Forward And Reverse Operation	145
Group 5 Combined Operation	147
1. Outline	147
2. Combined Swing And Boom Up Operation.	148
3. Combined Swing And Arm Operation	149
4. Combined Swing And Bucket Operation.	150
5. Combined Swing And Travel Operation	151
6. Combined Boom And Travel Operation	152
7. Combined Arm And Travel Operation	153
8. Combined Bucket And Travel Operation.	154
9. Combined Boom Up And Bucket Operation	155
SECTION 4 ELECTRICAL SYSTEM	156
Group 1 Component Location	157
1. Location 1.	157
2. Location 2.	158
Memorandum.	161
1. Power Circuit	162
2. Starting Circuit.	164
3. Charging Circuit	166
4. Head And Work Light Circuit.	168
5. Beacon Lamp And Cab Light Circuit	170
6. Wiper And Washer Circuit	172

Group 3 Electrical Component Specification	177
Group 4 Connectors	185
1. Connector Destination	185
2. Connection Table For Connectors	189
SECTION 5 MECHATRONICS SYSTEM	208
Group 1 Outline	209
Group 2 Mode Selection System.	211
1. Power Mode Selection System	211
2. Work Mode Selection System	212
3. User Mode Selection System	213
Group 3 Automatic Deceleration System.	214
1. When Auto Idle Pilot Lamp On 2. When Auto Idle Pilot Lamp Off	214
Group 4 Power Boost System	215
Group 5 Travel Speed Control System.	216
Group 6 Automatic Warming Up System.	217
Group 7 Engine Overheat Prevention System	218
Group 8 Variable Power Control System.	219
Group 9 Attachment Flow Control System	220
Group 10 Anti-restart System	221
1. Anti-restart Function	221
Group 11 Self-diagnostic System	222
3. Machine Error Codes Table	223
4. Engine Fault Code	226
Group 12 Engine Control System	235
1. Mcu And Engine Ecm (electronic Control Module).	235
2. Mcu Assembly	235
Group 13 Eppr Valve.	236
1. Pump Eppr Valve.	236
2. Boom Priority Eppr Valve	239
Group 14 Monitoring System.	241
1. Outline	241
2. Cluster	241
3. Cluster Connector	243
Group 15 Fuel Warmer System	264
1. Specification.	264
2. Operation	264
3. Electric Circuit	264
SECTION 6 TROUBLESHOOTING	265
Group 1 Before Troubleshooting.	266
1. Introduction	266
2. Diagnosing Procedure	267
Group 2 Hydraulic And Mechanical System	269

1. Introduction	269
2. Drive System	270
3. Hydraulic System	272
4. Swing System	274
5. Travel System	278
6. Attachment System.	283
Group 3 Electrical System	289
1. When Starting Switch Is Turned On, Monitor Panel Display Does Not Appear.	289
3. Battery Charging Warning Lamp Lights Up(starting Switch : On)	291
4. When Coolant Overheat Warning Lamp Lights Up (engine Is Started).	292
5. When Air Cleaner Warning Lamp Lights Up (engine Is Started).	293
6. When Engine Oil Pressure Warning Lamp Lights Up (engine Is Started).	294
7. When Hydraulic Oil Temperature Warning Lamp Lights Up (engine Is Started)	295
8. When Coolant Temperature Gauge Does Not Operate (hcespn 304, Fmi 3 Or 4)	296
9. When Fuel Gauge Does Not Operate(hcespn 301, Fmi 3 Or 4).	297
10. When Safety Solenoid Does Not Operate.	298
11. When Travel Speed 1, 2 Does Not Operate (hcespn 167, Fmi 5 Or 6)	299
12. When Engine Does Not Start (Lights Up Condition)	300
13. When Starting Switch On Does Not Operate	301
14. When Starting Switch Is Turned On, Wiper Motor Does Not Operate	302
15. When Starting Switch Is Turned On, Head Lamp Does Not Lights Up.	303
16. When Starting Switch Is Turned On, Work Lamp Does Not Lights Up.	304
Group 4 Mechatronics Systegroup System	305
1. All Actuators Speed Are Slow	305
2. Engine Stall	307
3. Malfunction Of Cluster Or Mode Selection System	309
4. Malfunction Of Accel Dial	310
5. Auto Decel System Does Not Work.	312
6. Malfunction Of Pump 1 Pressure Sensor	314
7. Malfunction Of Pump 2 Pressure Sensor	316
8. Malfunction Of Pump 3 Pressure Sensor	318
9. Malfunction Of Negative 1 Pressure Sensor	320
10. Malfunction Of Negative 2 Pressure Sensor.	322
11. Malfunction Of Swing Pressure Sensor.	324
12. Malfunction Of Arm In/out & Bucket In Pressure Sensor	326
13. Malfunction Of Boom Up Pressure Sensor	328
14. Malfunction Of Power Max	330
15. Malfunction Of Boom Priority Eppr Valve	332
16. Malfunction Of Arm Regeneration Solenoid	333
SECTION 7 MAINTENANCE STANDARD	335

Group 1 Operational Performance Test	336
1. Purpose.	336
2. Terminology.	337
3. Operation For Performance Tests	338
Group 2 Major Component.	356
1. Main Pump	356
2. Main Control Valve	357
3. Swing Device	358
4. Travel Motor.	359
5. Rcv Lever.	360
6. Rcv Pedal.	361
7. Turning Joint	362
8. Cylinder.	363
Group 3 Track And Work Equipment.	364
1. Track	364
2. Work Equipment	370
SECTION 8 DISASSEMBLY AND ASSEMBLY	371
Group 1 Precautions	372
1. Removal Work.	372
2. Install Work	373
3. Completing Work.	374
Group 2 Tightening Torque.	375
1. Major Components	375
2. Torque Chart	376
Group 3 Pump Device	378
1. Removal And Install.	378
2. Main Pump (1/2)	380
3. Regulator	390
Group 4 Main Control Valve	401
1. Removal And Install Of Motor	401
2. Structure (1/4)	402
3. Disassembly And Assembly	406
Group 5 Swing Device	425
1. Removal And Install Of Motor	425
2. Disassembly And Assembly Of Swing Motor.	426
3. Removal And Install Of Reduction Gear	440
4. Disassembly And Assembly Of Reduction Gear	441
4. Assembly Reduction Unit	446
Group 6 Travel Device	458
1. Removal And Install.	458
2. Travel Motor.	459
3. Outline Of Disassembling	461
4. Outline For Assembling	467

Group 7 Rcv Lever	490
1. Removal And Install	490
2. Disassembly And Assembly	491
Group 8 Turning Joint	504
1. Removal And Install	504
2. Disassembly And Assembly	505
Group 9 Boom, Arm And Bucket Cylinder	509
1. Removal And Install	509
2. Disassembly And Assembly	515
Group 10 Undercarriage	526
1. Track Link	526
2. Carrier Roller	527
3. Track Roller	528
4. Idler And Recoil Spring	529
Group 11 Work Equipment.	538
1. Structure	538
2. Removal And Install	539
SECTION 9 COMPONENT MOUNTING TORQUE	542
Group 1 Introduction Guide.	543
Group 2 Engine System	544
Group 3 Electric System	546
Group 4 Hydraulic System	548
Group 5 Undercarriage.	551
Group 6 Structure	552
Group 7 Work Equipment	556

1. STRUCTURE

This service manual has been prepared as an aid to improve the quality of repairs by giving the serviceman an accurate understanding of the product and by showing him the correct way to perform repairs and make judgements. Make sure you understand the contents of this manual and use it to full effect at every opportunity.

This service manual mainly contains the necessary technical information for operations performed in a service workshop.

For ease of understanding, the manual is divided into the following sections.

SECTION 1 GENERAL

This section explains the safety hints and gives the specification of the machine and major components.

SECTION 2 STRUCTURE AND FUNCTION

This section explains the structure and function of each component. It serves not only to give an understanding of the structure, but also serves as reference material for troubleshooting.

SECTION 3 HYDRAULIC SYSTEM

This section explains the hydraulic circuit, single and combined operation.

SECTION 4 ELECTRICAL SYSTEM

This section explains the electrical circuit, monitoring system and each component. It serves not only to give an understanding electrical system, but also serves as reference material for trouble shooting.

SECTION 5 MECHATRONICS SYSTEM

This section explains the computer aided power optimization system and each component.

SECTION 6 TROUBLESHOOTING

This section explains the troubleshooting charts correlating **problems** to **causes**.

SECTION 7 MAINTENANCE STANDARD

This section gives the judgement standards when inspecting disassembled parts.

SECTION 8 DISASSEMBLY AND ASSEMBLY

This section explains the order to be followed when removing, installing, disassembling or assembling each component, as well as precautions to be taken for these operations.

SECTION 9 COMPONENT MOUNTING TORQUE

This section shows bolt specifications and standard torque values needed when mounting components to the machine.

The specifications contained in this shop manual are subject to change at any time and without any advance notice. Contact your HYUNDAI distributor for the latest information.

2. HOW TO READ THE SERVICE MANUAL

Distribution and updating

Any additions, amendments or other changes will be sent to HYUNDAI distributors.

Get the most up-to-date information before you start any work.

Filing method

1. See the page number on the bottom of the page.

File the pages in correct order.

2. Following examples shows how to read the page number.

Example 1

2 - 3

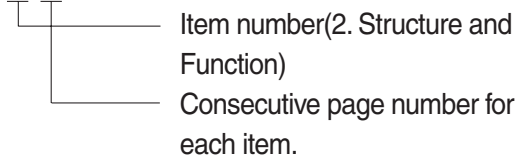

3. Additional pages : Additional pages are indicated by a hyphen(-) and number after the page number. File as in the example.

10 - 4

10 - 4 - 1

10 - 4 - 2

10 - 5

Added pages

Revised edition mark(①②③...)

When a manual is revised, an edition mark is recorded on the bottom outside corner of the pages.

Revisions

Revised pages are shown at the list of revised pages on the between the contents page and section 1 page.

Symbols

So that the shop manual can be of ample practical use, important places for safety and quality are marked with the following symbols.

Symbol	Item	Remarks
	Safety	Special safety precautions are necessary when performing the work.
		Extra special safety precautions are necessary when performing the work because it is under internal pressure.
	Caution	Special technical precautions or other precautions for preserving standards are necessary when performing the work.

3. CONVERSION TABLE

Method of using the Conversion Table

The Conversion Table in this section is provided to enable simple conversion of figures. For details of the method of using the Conversion Table, see the example given below.

Example

1. Method of using the Conversion Table to convert from millimeters to inches

Convert 55mm into inches.

- (1) Locate the number 50 in the vertical column at the left side, take this as (a), then draw a horizontal line from (a).
- (2) Locate the number 5 in the row across the top, take this as (b), then draw a perpendicular line down from (b).
- (3) Take the point where the two lines cross as (c). This point (c) gives the value when converting from millimeters to inches. Therefore, 55mm = 2.165 inches.

2. Convert 550mm into inches.

- (1) The number 550 does not appear in the table, so divide by 10 (Move the decimal point one place to the left) to convert it to 55mm.
- (2) Carry out the same procedure as above to convert 55mm to 2.165 inches.
- (3) The original value (550mm) was divided by 10, so multiply 2.165 inches by 10 (Move the decimal point one place to the right) to return to the original value.
This gives 550mm = 21.65 inches.

Millimeters to inches

(b)

1mm = 0.03937 in

	0	1	2	3	4	5	6	7	8	9
0		0.039	0.079	0.118	0.157	0.197	0.236	0.276	0.315	0.354
10	0.394	0.433	0.472	0.512	0.551	0.591	0.630	0.669	0.709	0.748
20	0.787	0.827	0.866	0.906	0.945	0.984	1.024	1.063	1.102	1.142
30	1.181	1.220	1.260	1.299	1.339	1.378	1.417	1.457	1.496	1.536
40	1.575	1.614	1.654	1.693	1.732	1.772	1.811	1.850	1.890	1.929
(a) 50	1.969	2.008	2.047	2.087	2.126	(c) 2.165	2.205	2.244	2.283	2.323
60	2.362	2.402	2.441	2.480	2.520	2.559	2.598	2.638	2.677	2.717
70	2.756	2.795	2.835	2.874	2.913	2.953	2.992	3.032	3.071	3.110
80	3.150	3.189	3.228	3.268	3.307	3.346	3.386	3.425	3.465	3.504
90	3.543	3.583	3.622	3.661	3.701	3.740	3.780	3.819	3.858	3.898

Millimeters to inches

1mm = 0.03937in

	0	1	2	3	4	5	6	7	8	9
0		0.039	0.079	0.118	0.157	0.197	0.236	0.276	0.315	0.354
10	0.394	0.433	0.472	0.512	0.551	0.591	0.630	0.669	0.709	0.748
20	0.787	0.827	0.866	0.906	0.945	0.984	1.024	1.063	1.102	1.142
30	1.181	1.220	1.260	1.299	1.339	1.378	1.417	1.457	1.496	1.536
40	1.575	1.614	1.654	1.693	1.732	1.772	1.811	1.850	1.890	1.929
50	1.969	2.008	2.047	2.087	2.126	2.165	2.205	2.244	2.283	2.323
60	2.362	2.402	2.441	2.480	2.520	2.559	2.598	2.638	2.677	2.717
70	2.756	2.795	2.835	2.874	2.913	2.953	2.992	3.032	3.071	3.110
80	3.150	3.189	3.228	3.268	3.307	3.346	3.386	3.425	3.465	3.504
90	3.543	3.583	3.622	3.661	3.701	3.740	3.780	3.819	3.858	3.898

Kilogram to Pound

1kg = 2.2046lb

	0	1	2	3	4	5	6	7	8	9
0		2.20	4.41	6.61	8.82	11.02	13.23	15.43	17.64	19.84
10	22.05	24.25	26.46	28.66	30.86	33.07	35.27	37.48	39.68	41.89
20	44.09	46.30	48.50	50.71	51.91	55.12	57.32	59.5	61.73	63.93
30	66.14	68.34	70.55	72.75	74.96	77.16	79.37	81.57	83.78	85.98
40	88.18	90.39	92.59	94.80	97.00	99.21	101.41	103.62	105.82	108.03
50	110.23	112.44	114.64	116.85	119.05	121.25	123.46	125.66	127.87	130.07
60	132.28	134.48	136.69	138.89	141.10	143.30	145.51	147.71	149.91	152.12
70	154.32	156.53	158.73	160.94	163.14	165.35	167.55	169.76	171.96	174.17
80	176.37	178.57	180.78	182.98	185.19	187.39	189.60	191.80	194.01	196.21
90	198.42	200.62	202.83	205.03	207.24	209.44	211.64	213.85	216.05	218.26

Liter to U.S. Gallon

1 l = 0.2642 U.S.Gal

	0	1	2	3	4	5	6	7	8	9
0		0.264	0.528	0.793	1.057	1.321	1.585	1.849	2.113	2.378
10	2.642	2.906	3.170	3.434	3.698	3.963	4.227	4.491	4.755	5.019
20	5.283	5.548	5.812	6.076	6.340	6.604	6.869	7.133	7.397	7.661
30	7.925	8.189	8.454	8.718	8.982	9.246	9.510	9.774	10.039	10.303
40	10.567	10.831	11.095	11.359	11.624	11.888	12.152	12.416	12.680	12.944
50	13.209	13.473	13.737	14.001	14.265	14.529	14.795	15.058	15.322	15.586
60	15.850	16.115	16.379	16.643	16.907	17.171	17.435	17.700	17.964	18.228
70	18.492	18.756	19.020	19.285	19.549	19.813	20.077	20.341	20.605	20.870
80	21.134	21.398	21.662	21.926	22.190	22.455	22.719	22.983	23.247	23.511
90	23.775	24.040	24.304	24.568	24.832	25.096	25.361	25.625	25.889	26.153

Liter to U.K. Gallon

1 l = 0.21997 U.K.Gal

	0	1	2	3	4	5	6	7	8	9
0		0.220	0.440	0.660	0.880	1.100	1.320	1.540	1.760	1.980
10	2.200	2.420	2.640	2.860	3.080	3.300	3.520	3.740	3.950	4.179
20	4.399	4.619	4.839	5.059	5.279	5.499	5.719	5.939	6.159	6.379
30	6.599	6.819	7.039	7.259	7.479	7.699	7.919	8.139	8.359	8.579
40	8.799	9.019	9.239	9.459	9.679	9.899	10.119	10.339	10.559	10.778
50	10.998	11.281	11.438	11.658	11.878	12.098	12.318	12.528	12.758	12.978
60	13.198	13.418	13.638	13.858	14.078	14.298	14.518	14.738	14.958	15.178
70	15.398	15.618	15.838	16.058	16.278	16.498	16.718	16.938	17.158	17.378
80	17.598	17.818	18.037	18.257	18.477	18.697	18.917	19.137	19.357	19.577
90	19.797	20.017	20.237	20.457	20.677	20.897	21.117	21.337	21.557	21.777

kgf · m to lbf · ft

1 kgf · m = 7.233lbf · ft

	0	1	2	3	4	5	6	7	8	9
		7.2	14.5	21.7	28.9	36.2	43.4	50.6	57.9	65.1
10	72.3	79.6	86.8	94.0	101.3	108.5	115.7	123.0	130.2	137.4
20	144.7	151.9	159.1	166.4	173.6	180.8	188.1	195.3	202.5	209.8
30	217.0	224.2	231.5	238.7	245.9	253.2	260.4	267.6	274.9	282.1
40	289.3	296.6	303.8	311.0	318.3	325.5	332.7	340.0	347.2	354.4
50	361.7	368.9	376.1	383.4	390.6	397.8	405.1	412.3	419.5	426.8
60	434.0	441.2	448.5	455.7	462.9	470.2	477.4	484.6	491.8	499.1
70	506.3	513.5	520.8	528.0	535.2	542.5	549.7	556.9	564.2	571.4
80	578.6	585.9	593.1	600.3	607.6	614.8	622.0	629.3	636.5	643.7
90	651.0	658.2	665.4	672.7	679.9	687.1	694.4	701.6	708.8	716.1
100	723.3	730.5	737.8	745.0	752.2	759.5	766.7	773.9	781.2	788.4
110	795.6	802.9	810.1	817.3	824.6	831.8	839.0	846.3	853.5	860.7
120	868.0	875.2	882.4	889.7	896.9	904.1	911.4	918.6	925.8	933.1
130	940.3	947.5	954.8	962.0	969.2	976.5	983.7	990.9	998.2	10005.4
140	1012.6	1019.9	1027.1	1034.3	1041.5	1048.8	1056.0	1063.2	1070.5	1077.7
150	1084.9	1092.2	1099.4	1106.6	1113.9	1121.1	1128.3	1135.6	1142.8	1150.0
160	1157.3	1164.5	1171.7	1179.0	1186.2	1193.4	1200.7	1207.9	1215.1	1222.4
170	1129.6	1236.8	1244.1	1251.3	1258.5	1265.8	1273.0	1280.1	1287.5	1294.7
180	1301.9	1309.2	1316.4	1323.6	1330.9	1338.1	1345.3	1352.6	1359.8	1367.0
190	1374.3	1381.5	1388.7	1396.0	1403.2	1410.4	1417.7	1424.9	1432.1	1439.4

kgf/cm² to lbf/in²

1 kgf / cm² = 14.2233 lbf / in²

	0	1	2	3	4	5	6	7	8	9
		14.2	28.4	42.7	56.9	71.1	85.3	99.6	113.8	128.0
10	142.2	156.5	170.7	184.9	199.1	213.4	227.6	241.8	256.0	270.2
20	284.5	298.7	312.9	327.1	341.4	355.6	369.8	384.0	398.3	412.5
30	426.7	440.9	455.1	469.4	483.6	497.8	512.0	526.3	540.5	554.7
40	568.9	583.2	597.4	611.6	625.8	640.1	654.3	668.5	682.7	696.9
50	711.2	725.4	739.6	753.8	768.1	782.3	796.5	810.7	825.0	839.2
60	853.4	867.6	881.8	896.1	910.3	924.5	938.7	953.0	967.2	981.4
70	995.6	1010	1024	1038	1053	1067	1081	1095	1109	1124
80	1138	1152	1166	1181	1195	1209	1223	1237	1252	1266
90	1280	1294	1309	1323	1337	1351	1365	1380	1394	1408
100	1422	1437	1451	1465	1479	1493	1508	1522	1536	1550
110	1565	1579	1593	1607	1621	1636	1650	1664	1678	1693
120	1707	1721	1735	1749	1764	1778	1792	1806	1821	1835
130	1849	2863	1877	1892	1906	1920	1934	1949	1963	1977
140	1991	2005	2020	2034	2048	2062	2077	2091	2105	2119
150	2134	2148	2162	2176	2190	2205	2219	2233	2247	2262
160	2276	2290	2304	2318	2333	2347	2361	2375	2389	2404
170	2418	2432	2446	2460	2475	2489	2503	2518	2532	2546
180	2560	2574	2589	5603	2617	2631	2646	2660	2674	2688
200	2845	2859	2873	2887	2901	2916	2930	2944	2958	2973
210	2987	3001	3015	3030	3044	3058	3072	3086	3101	3115
220	3129	3143	3158	3172	3186	3200	3214	3229	3243	3257
230	3271	3286	3300	3314	3328	3343	3357	3371	3385	3399
240	3414	3428	3442	3456	3470	3485	3499	3513	3527	3542

TEMPERATURE

Fahrenheit-Centigrade Conversion.

A simple way to convert a fahrenheit temperature reading into a centigrade temperature reading or vice versa is to enter the accompanying table in the center or boldface column of figures.

These figures refer to the temperature in either Fahrenheit or Centigrade degrees.

If it is desired to convert from Fahrenheit to Centigrade degrees, consider the center column as a table of Fahrenheit temperatures and read the corresponding Centigrade temperature in the column at the left.

If it is desired to convert from Centigrade to Fahrenheit degrees, consider the center column as a table of Centigrade values, and read the corresponding Fahrenheit temperature on the right.

°C	°F	°C	°F	°C	°F	°C	°F	°C	°F	°C	°F
-40.4	-40	-40.0	-11.7	11	51.8	7.8	46	114.8	27.2	81	117.8
-37.2	-35	-31.0	-11.1	12	53.6	8.3	47	116.6	27.8	82	179.6
-34.4	-30	-22.0	-10.6	13	55.4	8.9	48	118.4	28.3	83	181.4
-31.7	-25	-13.0	-10.0	14	57.2	9.4	49	120.2	28.9	84	183.2
-28.9	-20	-4.0	-9.4	15	59.0	10.0	50	122.0	29.4	85	185.0
-28.3	-19	-2.2	-8.9	16	60.8	10.6	51	123.8	30.0	86	186.8
-27.8	-18	-0.4	-8.3	17	62.6	11.1	52	125.6	30.6	87	188.6
-27.2	-17	1.4	-7.8	18	64.4	11.7	53	127.4	31.1	88	190.4
-26.7	-16	3.2	-6.7	20	68.0	12.8	55	131.0	32.2	90	194.0
-26.1	-15	5.0	-6.7	20	68.0	12.8	55	131.0	32.2	90	194.0
-25.6	-14	6.8	-6.1	21	69.8	13.3	56	132.8	32.8	91	195.8
-25.0	-13	8.6	-5.6	22	71.6	13.9	57	134.6	33.3	92	197.6
-24.4	-12	10.4	-5.0	23	73.4	14.4	58	136.4	33.9	93	199.4
-23.9	-11	12.2	-4.4	24	75.2	15.0	59	138.2	34.4	94	201.2
-23.3	-10	14.0	-3.9	25	77.0	15.6	60	140.0	35.0	95	203.0
-22.8	-9	15.8	-3.3	26	78.8	16.1	61	141.8	35.6	96	204.8
-22.2	-8	17.6	-2.8	27	80.6	16.7	62	143.6	36.1	97	206.6
-21.7	-7	19.4	-2.2	28	82.4	17.2	63	145.4	36.7	98	208.4
-21.1	-6	21.2	-1.7	29	84.2	17.8	64	147.2	37.2	99	210.2
-20.6	-5	23.0	-1.1	35	95.0	21.1	70	158.0	51.7	125	257.0
-20.0	-4	24.8	-0.6	31	87.8	18.9	66	150.8	40.6	105	221.0
-19.4	-3	26.6	0	32	89.6	19.4	67	152.6	43.3	110	230.0
-18.9	-2	28.4	0.6	33	91.4	20.0	68	154.4	46.1	115	239.0
-18.3	-1	30.2	1.1	34	93.2	20.6	69	156.2	48.9	120	248.0
-17.8	0	32.0	1.7	35	95.0	21.1	70	158.0	51.7	125	257.0
-17.2	1	33.8	2.2	36	96.8	21.7	71	159.8	54.4	130	266.0
-16.7	2	35.6	2.8	37	98.6	22.2	72	161.6	57.2	135	275.0
-16.1	3	37.4	3.3	38	100.4	22.8	73	163.4	60.0	140	284.0
-15.6	4	39.2	3.9	39	102.2	23.3	74	165.2	62.7	145	293.0
-15.0	5	41.0	4.4	40	104.0	23.9	75	167.0	65.6	150	302.0
-14.4	6	42.8	5.0	41	105.8	24.4	76	168.8	68.3	155	311.0
-13.9	7	44.6	5.6	42	107.6	25.0	77	170.6	71.1	160	320.0
-13.3	8	46.4	6.1	43	109.4	25.6	78	172.4	73.9	165	329.0
-12.8	9	48.2	6.7	44	111.2	26.1	79	174.2	76.7	170	338.0
-12.2	10	50.0	7.2	45	113.0	26.7	80	176.0	79.4	172	347.0

SECTION 1 GENERAL



Group 1 Safety Hints	1-1
Group 2 Specifications	1-10

SECTION 1 GENERAL

GROUP 1 SAFETY

FOLLOW SAFE PROCEDURE

Unsafe work practices are dangerous. Understand service procedure before doing work; Do not attempt shortcuts.

WEAR PROTECTIVE CLOTHING

Wear close fitting clothing and safety equipment appropriate to the job.

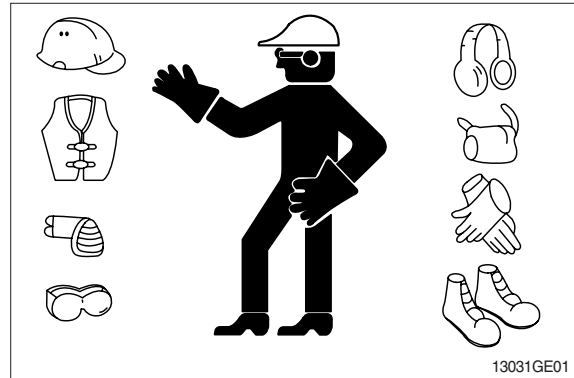

WARN OTHERS OF SERVICE WORK

Unexpected machine movement can cause serious injury.

Before performing any work on the excavator, attach a 「Do Not Operate」 tag on the right side control lever.

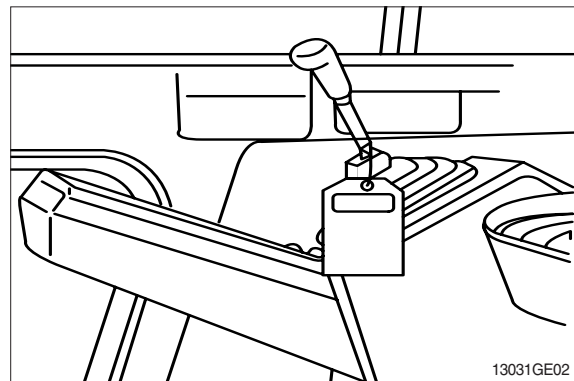

USE HANDHOLDS AND STEPS

Falling is one of the major causes of personal injury.

When you get on and off the machine, always maintain a three point contact with the steps and handrails and face the machine. Do not use any controls as handholds.

Never jump on or off the machine. Never mount or dismount a moving machine.

Be careful of slippery conditions on platforms, steps, and handrails when leaving the machine.

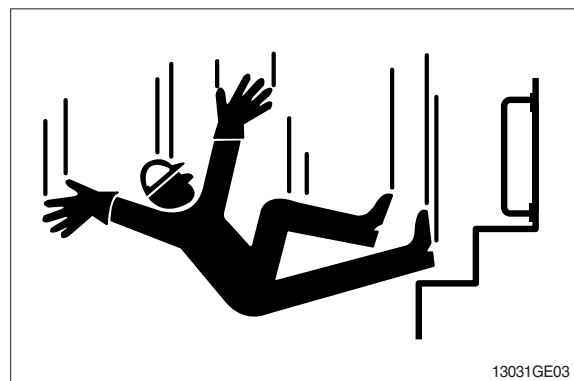

PREPARE FOR EMERGENCIES

Be prepared if a fire starts.

Keep a first aid kit and fire extinguisher handy.

Keep emergency numbers for doctors, ambulance service, hospital, and fire department near your telephone.

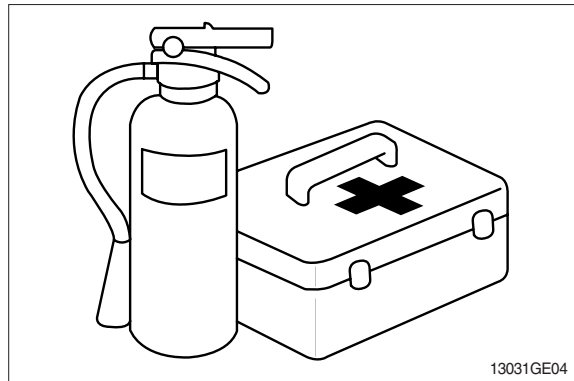

PROTECT AGAINST FLYING DEBRIS

Guard against injury from flying pieces of metal or debris; Wear goggles or safety glasses.

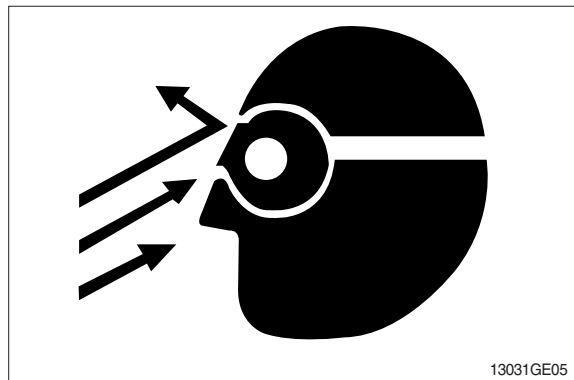

PROTECT AGAINST NOISE

Prolonged exposure to loud noise can cause impairment or loss of hearing.

Wear a suitable hearing protective device such as earmuffs or earplugs to protect against objectionable or uncomfortable loud noises.

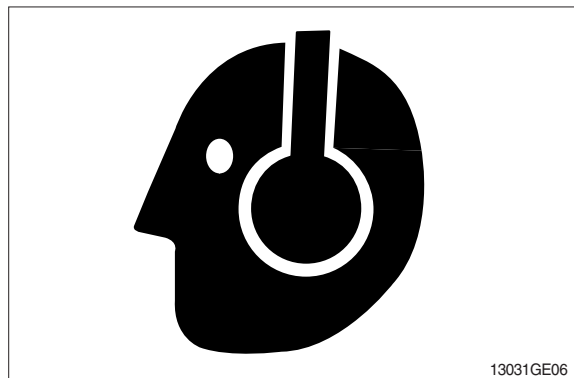

AVOID POWER LINES

Serious injury or death can result from contact with electric lines.

Never move any part of the machine or load closer to electric line than 3m(10ft) plus twice the line insulator length.

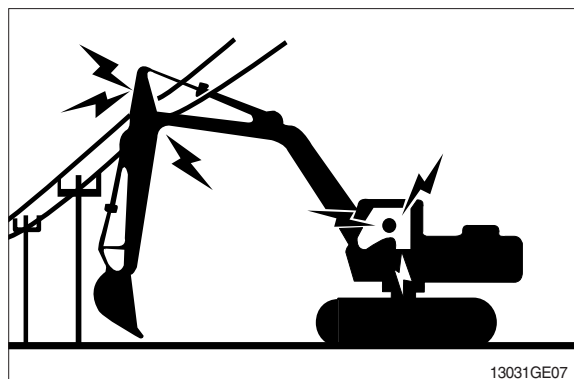

KEEP RIDERS OFF EXCAVATOR

Only allow the operator on the excavator. Keep riders off.

Riders on excavator are subject to injury such as being struck by foreign objects and being thrown off the excavator. Riders also obstruct the operator's view resulting in the excavator being operated in an unsafe manner.

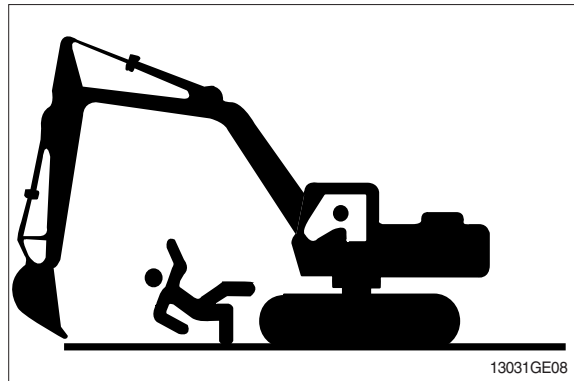

MOVE AND OPERATE MACHINE SAFELY

Bystanders can be run over. Know the location of bystanders before moving, swinging, or operating the machine.

Always keep the travel alarm in working condition. It warns people when the excavator starts to move.

Use a signal person when moving, swinging, or operating the machine in congested areas. Coordinate hand signals before starting the excavator.

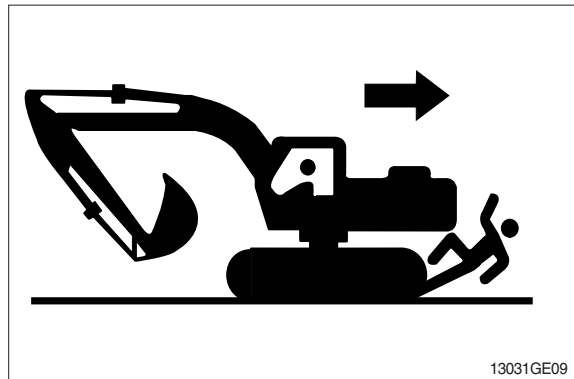

OPERATE ONLY FROM OPERATOR'S SEAT

Avoid possible injury machine damage. Do not start engine by shorting across starter terminals.

NEVER start engine while standing on ground. Start engine only from operator's seat.



PARK MACHINE SAFELY

Before working on the machine:

- Park machine on a level surface.
- Lower bucket to the ground.
- Turn auto idle switch off.
- Run engine at 1/2 speed without load for 2 minutes.
- Turn key switch to OFF to stop engine. Remove key from switch.
- Move pilot control shutoff lever to locked position.
- Allow engine to cool.

SUPPORT MACHINE PROPERLY

Always lower the attachment or implement to the ground before you work on the machine. If you must work on a lifted machine or attachment, securely support the machine or attachment.

Do not support the machine on cinder blocks, hollow tiles, or props that may crumble under continuous load.

Do not work under a machine that is supported solely by a jack. Follow recommended procedures in this manual.

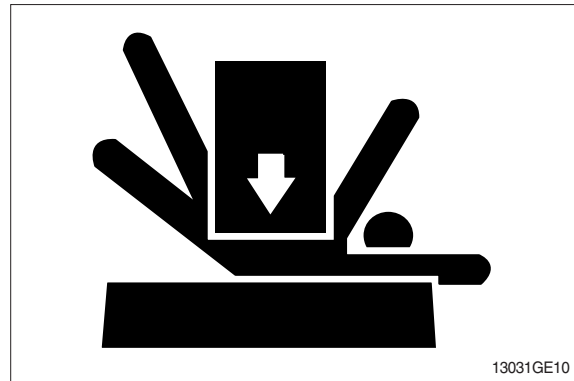

SERVICE COOLING SYSTEM SAFELY

Explosive release of fluids from pressurized cooling system can cause serious burns.

Shut off engine. Only remove filler cap when cool enough to touch with bare hands.

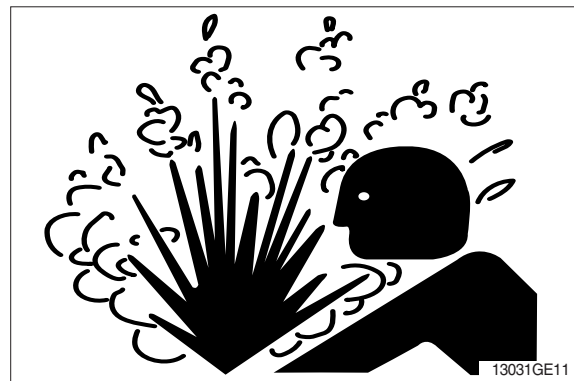

HANDLE FLUIDS SAFELY-AVOID FIRES

Handle fuel with care; It is highly flammable. Do not refuel the machine while smoking or when near open flame or sparks. Always stop engine before refueling machine. Fill fuel tank outdoors.

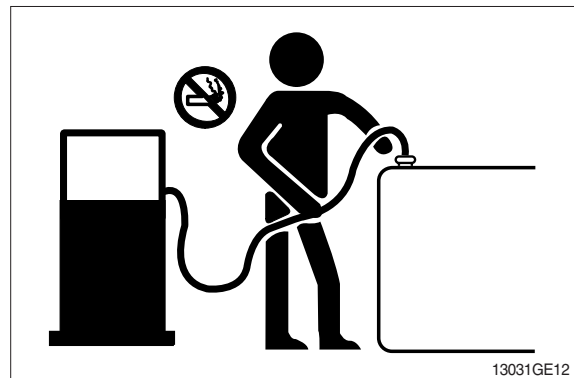

Store flammable fluids away from fire hazards. Do not incinerate or puncture pressurized containers.

Make sure machine is clean of trash, grease, and debris.

Do not store oily rags; They can ignite and burn spontaneously.

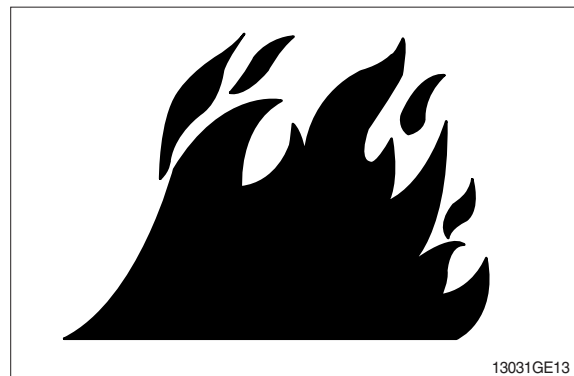

BEWARE OF EXHAUST FUMES

Prevent asphyxiation. Engine exhaust fumes can cause sickness or death.

If you must operate in a building, be positive there is adequate ventilation. Either use an exhaust pipe extension to remove the exhaust fumes or open doors and windows to bring enough outside air into the area.

REMOVE PAINT BEFORE WELDING OR HEATING

Avoid potentially toxic fumes and dust.

Hazardous fumes can be generated when paint is heated by welding, soldering, or using a torch.

Do all work outside or in a well ventilated area. Dispose of paint and solvent properly.

Remove paint before welding or heating:

- If you sand or grind paint, avoid breathing the dust.
Wear an approved respirator.
- If you use solvent or paint stripper, remove stripper with soap and water before welding. Remove solvent or paint stripper containers and other flammable material from area. Allow fumes to disperse at least 15 minutes before welding or heating.

ILLUMINATE WORK AREA SAFELY

Illuminate your work area adequately but safely. Use a portable safety light for working inside or under the machine. Make sure the bulb is enclosed by a wire cage. The hot filament of an accidentally broken bulb can ignite spilled fuel or oil.

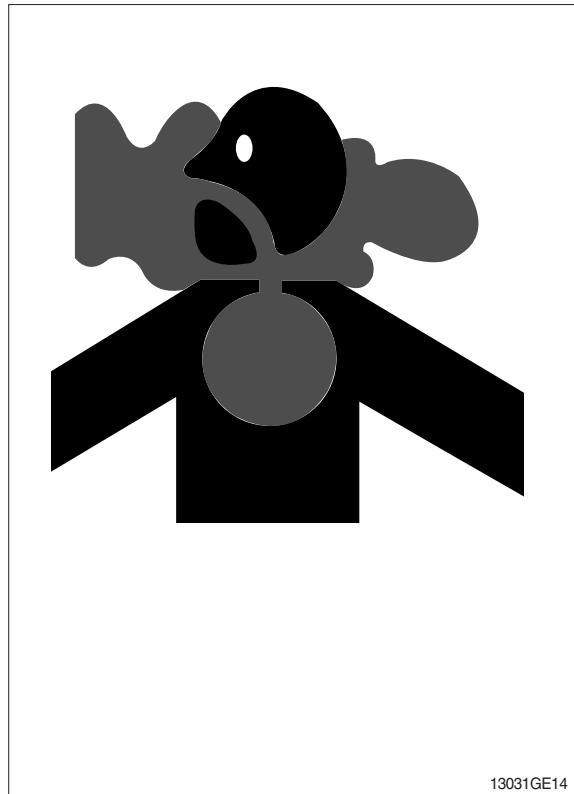

SERVICE MACHINE SAFELY

Tie long hair behind your head. Do not wear a necktie, scarf, loose clothing or necklace when you work near machine tools or moving parts. If these items were to get caught, severe injury could result.

Remove rings and other jewelry to prevent electrical shorts and entanglement in moving parts.

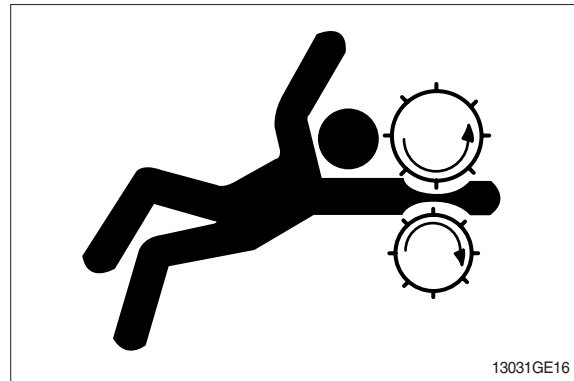

STAY CLEAR OF MOVING PARTS

Entanglements in moving parts can cause serious injury.

To prevent accidents, use care when working around rotating parts.

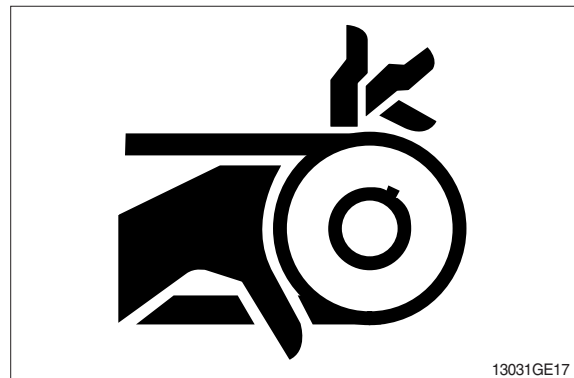

AVOID HIGH PRESSURE FLUIDS

Escaping fluid under pressure can penetrate the skin causing serious injury.

Avoid the hazard by relieving pressure before disconnecting hydraulic or other lines. Tighten all connections before applying pressure.

Search for leaks with a piece of cardboard. Protect hands and body from high pressure fluids.

If an accident occurs, see a doctor immediately. Any fluid injected into the skin must be surgically removed within a few hours or gangrene may result.

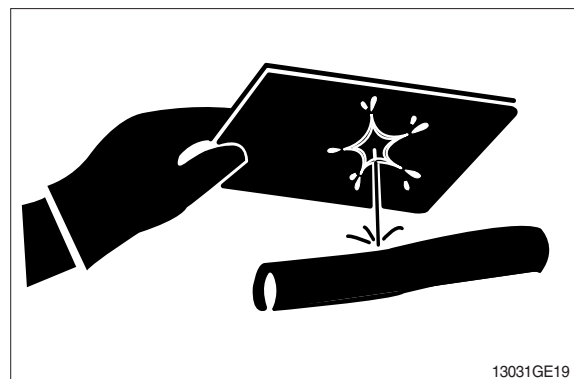

AVOID HEATING NEAR PRESSURIZED FLUID LINES

Flammable spray can be generated by heating near pressurized fluid lines, resulting in severe burns to yourself and bystanders. Do not heat by welding, soldering, or using a torch near pressurized fluid lines or other flammable materials.

Pressurized lines can be accidentally cut when heat goes beyond the immediate flame area. Install fire resisting guards to protect hoses or other materials.



PREVENT BATTERY EXPLOSIONS

Keep sparks, lighted matches, and flame away from the top of battery. Battery gas can explode.

Never check battery charge by placing a metal object across the posts. Use a volt-meter or hydrometer.

Do not charge a frozen battery; It may explode. Warm battery to 16° C (60° F).



PREVENT ACID BURNS

Sulfuric acid in battery electrolyte is poisonous. It is strong enough to burn skin, eat holes in clothing, and cause blindness if splashed into eyes.

Avoid the hazard by:

1. Filling batteries in a well-ventilated area.
2. Wearing eye protection and rubber gloves.
3. Avoiding breathing fumes when electrolyte is added.
4. Avoiding spilling or dripping electrolyte.
5. Use proper jump start procedure.

If you spill acid on yourself:

1. Flush your skin with water.
2. Apply baking soda or lime to help neutralize the acid.
3. Flush your eyes with water for 10-15 minutes. Get medical attention immediately.

If acid is swallowed:

1. Drink large amounts of water or milk.
2. Then drink milk of magnesia, beaten eggs, or vegetable oil.
3. Get medical attention immediately.

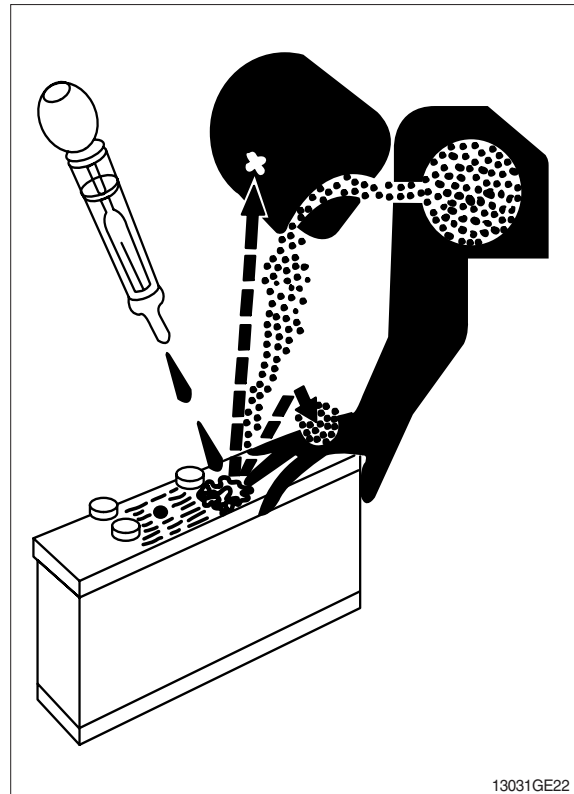

13031GE22

USE TOOLS PROPERLY

Use tools appropriate to the work. Makeshift tools, parts, and procedures can create safety hazards.

Use power tools only to loosen threaded tools and fasteners.

For loosening and tightening hardware, use the correct size tools. **DO NOT** use U.S. measurement tools on metric fasteners. Avoid bodily injury caused by slipping wrenches.

Use only recommended replacement parts. (See Parts catalogue.)

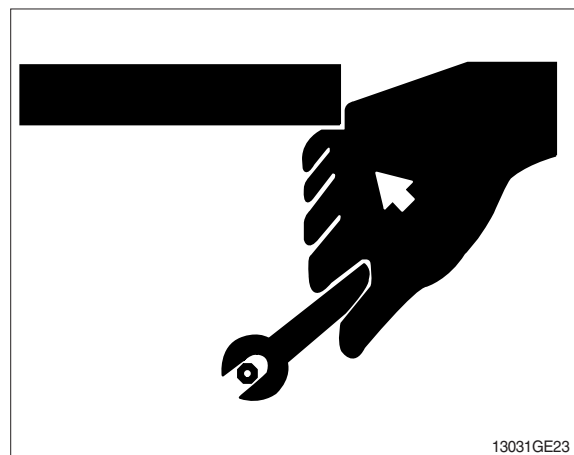

13031GE23

DISPOSE OF FLUIDS PROPERLY

Improperly disposing of fluids can harm the environment and ecology. Before draining any fluids, find out the proper way to dispose of waste from your local environmental agency.

Use proper containers when draining fluids. Do not use food or beverage containers that may mislead someone into drinking from them.

DO NOT pour oil into the ground, down a drain, or into a stream, pond, or lake. Observe relevant environmental protection regulations when disposing of oil, fuel, coolant, brake fluid, filters, batteries, and other harmful waste.

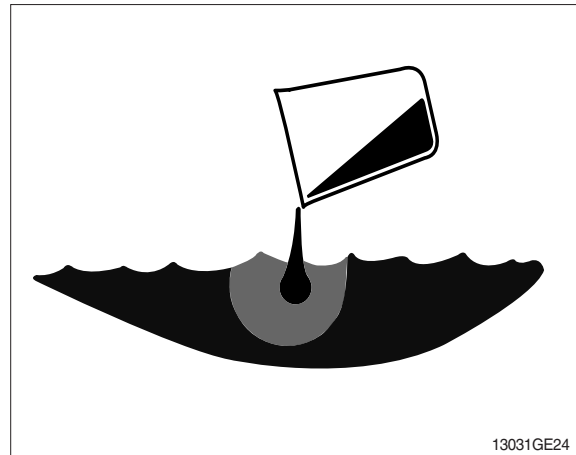

REPLACE SAFETY SIGNS

Replace missing or damaged safety signs. See the machine operator's manual for correct safety sign placement.

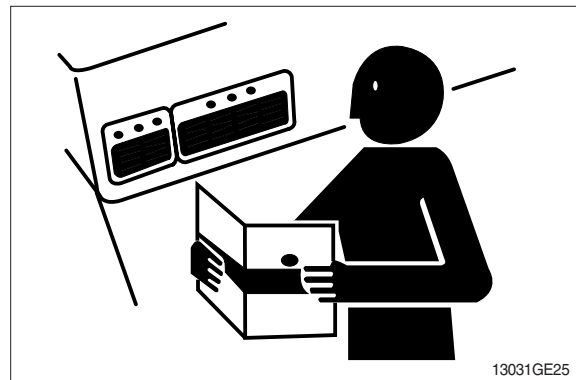

LIVE WITH SAFETY

Before returning machine to customer, make sure machine is functioning properly, especially the safety systems. Install all guards and shields.

GROUP 2 SPECIFICATIONS

1. MAJOR COMPONENT

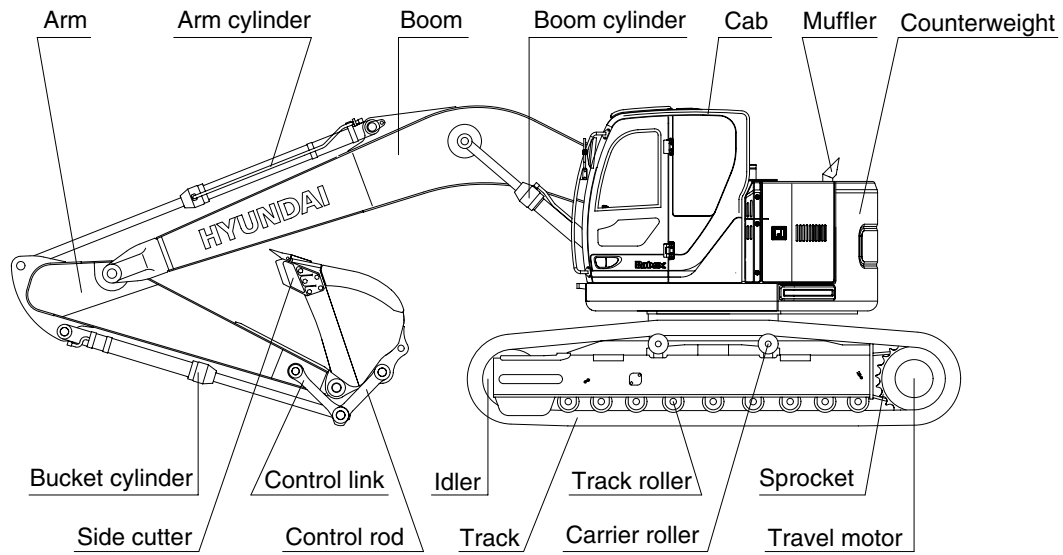
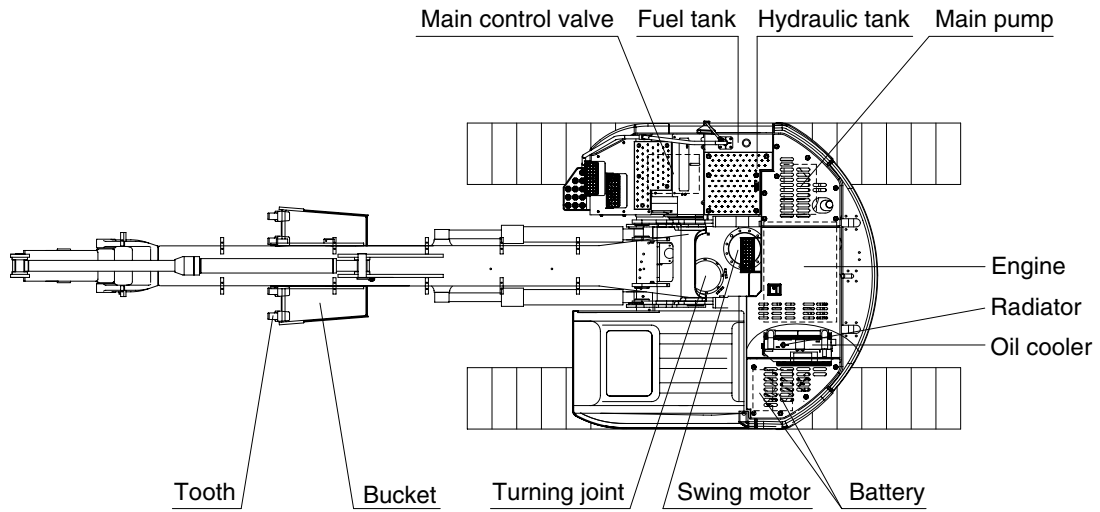

235Z92SP01

2. SPECIFICATIONS

1) R235LCR-9

· 5.68 m (18' 8") BOOM and 2.92 m (9' 7") ARM

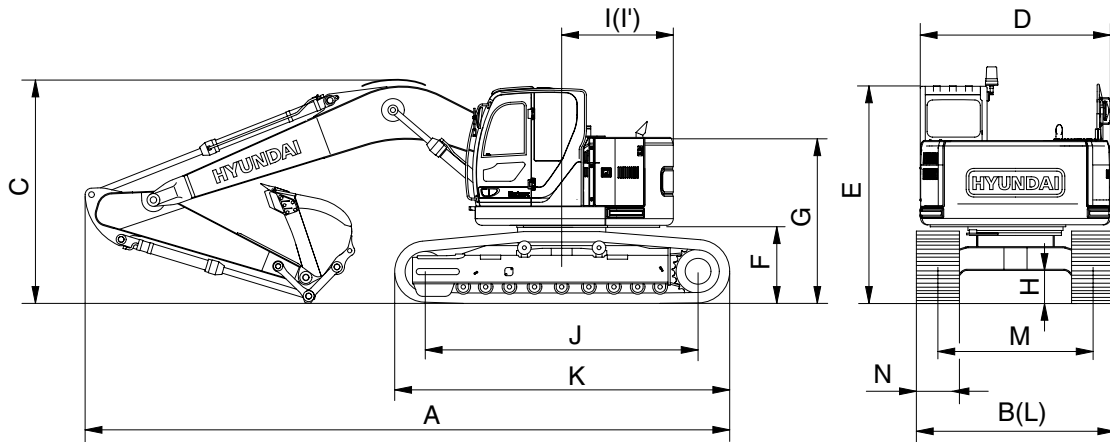

235Z92SP02

Description		Unit	Specification
Operating weight		kg (lb)	23800 (52470)
Bucket capacity (SAE heaped), standard		m ³ (yd ³)	0.8 (1.05)
Overall length	A	mm (ft-in)	8910 (29' 3")
Overall width, with 600mm shoe	B		2990 (9' 10")
Overall height	C		3020 (9' 11")
Superstructure width	D		2980 (9' 9")
Overall height of cab	E		2950 (9' 8")
Ground clearance of counterweight	F		1060 (3' 6")
Engine cover height	G		2385 (7' 10")
Minimum ground clearance	H		480 (1' 7")
Rear-end distance	I		1680 (5' 6")
Rear-end swing radius	I'		1680 (5' 6")
Distance between tumblers	J		3650 (12' 0")
Undercarriage length	K		4440 (14' 7")
Undercarriage width	L		2990 (9' 10")
Track gauge	M		2390 (7' 10")
Track shoe width, standard	N		600 (24")
Travel speed (low/high)			km/hr (mph)
Swing speed		rpm	12.0
Gradeability		Degree (%)	35 (70)
Ground pressure (600 mm shoe)		kgf/cm ² (psi)	0.51 (7.25)
Max traction force		kg (lb)	21100 (46500)

3. WORKING RANGE

1) R235LCR-9

· 5.68 m (18' 8") BOOM

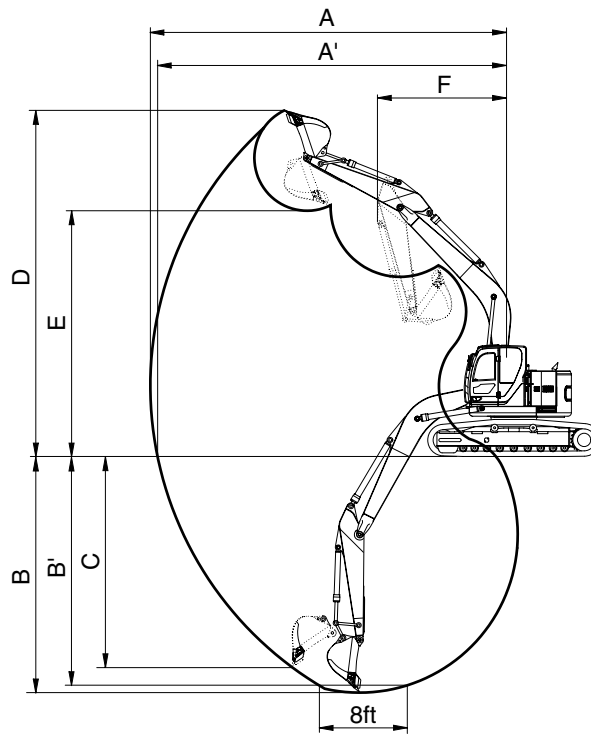

235Z92SP03

Description		2.0 m (6' 7") Arm	2.40 m (7' 10") Arm	2.92 m (9' 7") Arm
Max digging reach	A	9040 mm (29' 8")	9430 mm (30' 11")	9910 mm (32' 6")
Max digging reach on ground	A'	8860 mm (29' 1")	9260 mm (30' 5")	9750 mm (32' 0")
Max digging depth	B	5780 mm (19' 0")	6180 mm (20' 3")	6700 mm (22' 0")
Max digging depth (8 ft level)	B'	5550 mm (18' 3")	5980 mm (19' 7")	6530 mm (21' 5")
Max vertical wall digging depth	C	5140 mm (16' 10")	5710 mm (18' 9")	6270 mm (20' 7")
Max digging height	D	10090 mm (33' 1")	10420 mm (34' 2")	10830 mm (35' 6")
Max dumping height	E	7190 mm (23' 7")	7510 mm (24' 8")	7890 mm (25' 11")
Min swing radius	F	2860 mm (9' 5")	2550 mm (8' 4")	2350 mm (7' 9")
Bucket digging force	SAE	133.4 [144.8] kN		
		13600 [14770] kgf		
		29980 [32550] lbf		
	ISO	152.0 [165.0] kN		
		15500 [16830] kgf		
		34170 [37100] lbf		
Arm digging force	SAE	144.2 [156.5] kN	119.6 [129.9] kN	102.0 [110.7] kN
		14700 [15960] kgf	12200 [13250] kgf	10400 [11290] kgf
		32410 [35190] lbf	26900 [29210] lbf	22930 [24900] lbf
	ISO	151.0 [164.0] kN	125.5 [136.3] kN	106.9 [116.1] kN
		15400 [16720] kgf	12800 [13900] kgf	10900 [11830] kgf
		33950 [36860] lbf	28220 [30640] lbf	24030 [26090] lbf

[] : Power boost

4. WEIGHT

1) R235LCR-9













Item	R235LCR-9	
	kg	lb
Upperstructure assembly	11100	24470
Main frame weld assembly	1930	4250
Engine assembly	560	1240
Main pump assembly	140	310
Main control valve assembly	220	485
Swing motor assembly	240	530
Hydraulic oil tank assembly	160	350
Fuel tank assembly	150	330
Counterweight	5600	12350
Cab assembly	450	990
Lower chassis assembly	8700	19180
Track frame weld assembly	2720	6000
Swing bearing	290	640
Travel motor assembly	300	660
Turning joint	55	120
Track recoil spring	140	310
Idler	170	370
Carrier roller	20	45
Track roller	40	90
Track-chain assembly (600 mm standard triple grouser shoe)	1350	2980
Front attachment assembly (5.68 m boom, 2.92 m arm, 0.8 m ³ SAE heaped bucket)	3965	8740
5.68 m boom assembly	1520	3350
2.92 m arm assembly	750	1650
0.8 m ³ SAE heaped bucket	700	1540
Boom cylinder assembly	180	400
Arm cylinder assembly	290	640
Bucket cylinder assembly	175	390
Bucket control link assembly	170	370

5. LIFTING CAPACITIES

1) R235LCR-9

(1) 5.68 m (18' 8") boom, 2.92 m (9' 7") arm equipped with 0.80 m³ (SAE heaped) bucket, 600 mm (24") triple grouser shoe without dozer blade.













·  : Rating over-front ·  : Rating over-side or 360 degree

Load point height		Load radius										At max. reach		
		1.5 m (5 ft)		3.0 m (10 ft)		4.5 m (15 ft)		6.0 m (20 ft)		7.5 m (25 ft)		Capacity		Reach
														m (ft)
9.0 m (30.0 ft)	kg lb					*2970 *6550	*2970 *6550					*3620 *7980	*3620 *7980	6.12 (20.1)
7.5 m (25.0 ft)	kg lb							*3310 *7300	*3310 *7300			*3460 *7630	3180 7010	7.70 (25.3)
6.0 m (20.0 ft)	kg lb							*3770 *8310	*3770 *8310			*3430 *7560	2480 5470	8.66 (28.4)
4.5 m (15.0 ft)	kg lb					*4800 *10580	*4800 *10580	*4190 *9240	*4190 *9240	*3850 *8490	3140 6920	*3460 *7630	2120 4670	9.24 (30.3)
3.0 m (10.0 ft)	kg lb			*9720 *21430	*9720 *21430	*6230 *13730	*6230 *13730	*4850 *10690	4410 9720	*4150 *9150	3000 6510	*3510 *7740	1940 4280	9.52 (31.3)
1.5 m (5.0 ft)	kg lb			*9500 *20940	*9500 *20940	*7640 *16840	6400 14110	*5550 *12240	4100 9040	*4480 *9880	2850 6280	*3520 *7760	1880 4140	9.52 (31.3)
Ground Line	kg lb			*9890 *21800	*9890 *21800	*8440 *18610	6000 13230	*6040 *13320	3870 8530	*4710 *10380	2720 6000	*3640 *8020	1960 4320	9.24 (30.3)
-1.5 m (-5.0 ft)	kg lb	*8800 *19400	*8800 *19400	*12830 *28290	11650 25680	*8510 *18760	5840 12870	*6150 *13560	3750 8270	*4680 *10320	2660 5860	*3660 *8070	2190 4830	8.66 (28.4)
-3.0 m (-10 ft)	kg lb	*12230 *26960	*12230 *26960	*11420 *25180	*11420 *25180	*7880 *17370	5860 12920	*5730 *12630	3740 8250			*3550 *7830	2710 5970	7.69 (25.2)
-4.5 m (-15.0 ft)	kg lb			*8960 *19750	*8960 *19750	*6340 *13980	6030 13290					*2970 *6550	*2970 *6550	6.13 (20.0)

- Note
1. Lifting capacity are based on SAE J1097 and ISO 10567.
 2. Lifting capacity of the ROBEX series does not exceed 75% of tipping load with the machine on firm, level ground or 87% of full hydraulic capacity.
 3. The load point is a hook located on the back of the bucket.
 4. *indicates load limited by hydraulic capacity.

(2) 5.68 m (18' 8") boom, 2.92 m (9' 7") arm equipped with 0.80 m³ (SAE heaped) bucket, 600 mm (24") triple grouser shoe with dozer blade.

-  : Rating over-front
-  : Rating over-side or 360 degree

Load point height		Load radius										At max. reach				
		1.5 m (5 ft)		3.0 m (10 ft)		4.5 m (15 ft)		6.0 m (20 ft)		7.5 m (25 ft)		Capacity		Reach		
														Capacity	Reach	
9.0 m (30.0 ft)	kg					*2970	*2970							*3630	*3630	6.12
	lb					*6550	*6550							*8000	*8000	(20.1)
7.5 m (25.0 ft)	kg							*3310	*3310					*3460	*3460	7.70
	lb							*7300	*7300					*7630	*7630	(25.3)
6.0 m (20.0 ft)	kg							*3780	*3780					*3430	2880	8.66
	lb							*8330	*8330					*7560	6350	(28.4)
4.5 m (15.0 ft)	kg					*4810	*4810	*4190	*4190	*3860	3630	*3460	2490	9.24		
	lb					*10600	*10600	*9240	*9240	*8510	8000	*7630	5490	(30.3)		
3.0 m (10.0 ft)	kg			*9730	*9730	*6240	*6240	*4860	*4860	*4150	3490	*3512	2300	9.52		
	lb			*21450	*21450	*13760	*13760	*10710	*10710	*9150	7960	*7760	5270	(31.3)		
1.5 m (5.0 ft)	kg			*9500	*9500	*7650	7430	*5560	4770	*4490	3340	*3590	2250	9.52		
	lb			*20940	*20940	*16870	16380	*12260	10520	*9900	7360	*7910	4960	(31.3)		
Ground Line	kg			*9890	*9890	*8460	7020	*6050	4530	*4720	3210	*3650	2330	9.24		
	lb			*21800	*21800	*18650	15480	*13340	9990	*10410	7080	*8050	5140	(30.3)		
-1.5 m (-5.0 ft)	kg	*8800	*8800	*12860	*12860	*8530	6860	*6160	4410	*4690	3150	*3670	2600	8.66		
	lb	*19400	*19400	*28350	*25350	*18810	15120	*13580	9720	*10340	6940	*8090	5730	(28.4)		
-3.0 m (-10 ft)	kg	*12230	*12230	*11440	*11440	*7900	6880	*5740	4410			*3560	3190	7.69		
	lb	*26960	*26960	*25220	*25220	*17420	15170	*12650	9720			*7850	7030	(25.2)		
-4.5 m (-15.0 ft)	kg			*8990	*8990	*6360	*6060					*2980	*2980	6.13		
	lb			*19820	*19820	*14020	*14020					*6570	*6570	(20.0)		

- Note
1. Lifting capacity are based on SAE J1097 and ISO 10567.
 2. Lifting capacity of the ROBEX series does not exceed 75% of tipping load with the machine on firm, level ground or 87% of full hydraulic capacity.
 3. The load point is a hook located on the back of the bucket.
 4. *indicates load limited by hydraulic capacity.

6. BUCKET SELECTION GUIDE

1) GENERAL BUCKET

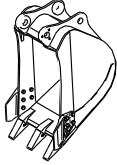
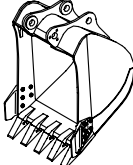
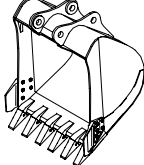
		
0.51 m ³ SAE heaped bucket	0.80, 0.87, 0.92, 1.10, 1.20 m ³ SAE heaped bucket	1.34 m ³ SAE heaped bucket

Capacity		Width		Weight	Recommendation		
					5.65 m (18' 6") Mono boom		
SAE heaped	CECE heaped	Without side cutter	With side cutter		2.0 m arm (6' 7")	2.4 m arm (7' 10")	2.92 m arm (9' 7")
0.51 m ³ (0.67 yd ³)	0.45 m ³ (0.59 yd ³)	700 mm (27.6")	820 mm (312.3)	570 kg (1260 lb)			
0.80 m ³ (1.05 yd ³)	0.70 m ³ (0.92 yd ³)	1000 mm (39.4")	1120 mm (44.1")	700 kg (1540 lb)			
0.87 m ³ (1.14 yd ³)	0.75 m ³ (0.98 yd ³)	1090 mm (42.9")	1210 mm (47.6")	740 kg (1630 lb)			
0.92 m ³ (1.20 yd ³)	0.80 m ³ (1.05 yd ³)	1150 mm (45.3")	1270 mm (50.0")	770 kg (1700 lb)			
1.10 m ³ (1.44 yd ³)	0.96 m ³ (1.26 yd ³)	1320 mm (52.0")	1440 mm (56.7")	830 kg (1830 lb)			
1.20 m ³ (1.57 yd ³)	1.00 m ³ (1.31 yd ³)	1400 mm (55.1")	1520 mm (60.0")	850 kg (1870 lb)			
1.34 m ³ (1.75 yd ³)	1.15 m ³ (1.50 yd ³)	1550 mm (61.0")	1670 mm (65.7")	920 kg (2030 lb)			

 Applicable for materials with density of 2000 kg/m³ (3370 lb/yd³) or less

 Applicable for materials with density of 1600 kg/m³ (2700 lb/yd³) or less

 Applicable for materials with density of 1100 kg/m³ (1850 lb/yd³) or less

2) HEAVY DUTY, ROCK-HEAVY DUTY AND SLOPE FINISHING BUCKET

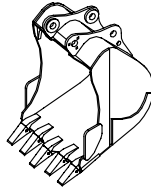
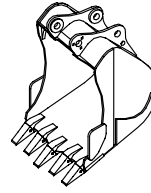
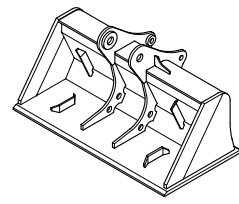
Heavy duty bucket	Rock-Heavy duty bucket	Slope finishing bucket
		
◆ 0.74, 0.90, 1.05 m ³ SAE heaped bucket	◎ 0.87 m ³ SAE heaped bucket	■ 0.75 m ³ SAE heaped bucket

Capacity		Width		Weight	Recommendation		
SAE heaped	SAE heaped	Without side cutter	With side cutter		5.65 m (18' 6") boom		
					2.0 m arm (6' 7")	2.4 m arm (7' 10")	2.92 m arm (9' 7")
◆ 0.74 m ³ (0.97 yd ³)	0.65 m ³ (0.85 yd ³)	985 mm (38.8")	-	770 kg (1700 lb)			
◆ 0.90 m ³ (1.18 yd ³)	0.80 m ³ (1.05 yd ³)	1070 mm (42.1")	-	810 kg (1790 lb)			
◆ 1.05 m ³ (1.37 yd ³)	0.92 m ³ (1.20 yd ³)	1290 mm (50.8")	-	890 kg (1960 lb)			
◎ 0.87 m ³ (1.14 yd ³)	0.75 m ³ (0.98 yd ³)	1140 mm (44.9")	-	900 kg (1980 lb)			
■ 0.75 m ³ (0.98 yd ³)	0.65 m ³ (0.85 yd ³)	1790 mm (70.5")	-	880 kg (1940 lb)			

◆ : Heavy duty bucket ◎ : Rock-Heavy duty bucket ■ : Slope finishing bucket

Applicable for materials with density of 2000 kg/m³ (3370 lb/yd³) or less

Applicable for materials with density of 1600 kg/m³ (2700 lb/yd³) or less

Applicable for materials with density of 1100 kg/m³ (1850 lb/yd³) or less

7. UNDERCARRIAGE

1) TRACKS

X-leg type center frame is integrally welded with reinforced box-section track frames. The design includes dry tracks, lubricated rollers, idlers, sprockets, hydraulic track adjusters with shock absorbing springs and assembled track-type tractor shoes with triple grousers.

2) TYPES OF SHOES

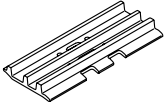
Model	Shapes		Triple grouser			
						
R235LCR-9	Shoe width	mm (in)	600 (24)	700 (28)	800 (32)	900 (36)
	Operating weight	kg (lb)	23800 (52470)	24150 (53240)	24415 (53830)	24680 (54410)
	Ground pressure	kgf/cm ² (psi)	0.51 (7.25)	0.44 (6.26)	0.39 (5.55)	0.35 (4.98)
	Overall width	mm (ft-in)	2990 (9' 10")	3090 (10' 2")	3190 (10' 6")	3290 (10' 10")

3) NUMBER OF ROLLERS AND SHOES ON EACH SIDE

Item	Quantity
Carrier rollers	2 EA
Track rollers	9 EA
Track shoes	49 EA

4) SELECTION OF TRACK SHOE

Suitable track shoes should be selected according to operating conditions.

Method of selecting shoes

Confirm the category from the list of applications in **table 2**, then use **table 1** to select the shoe. Wide shoes (categories B and C) have limitations on applications. Before using wide shoes, check the precautions, then investigate and study the operating conditions to confirm if these shoes are suitable.

Select the narrowest shoe possible to meet the required flotation and ground pressure. Application of wider shoes than recommendations will cause unexpected problem such as bending of shoes, crack of link, breakage of pin, loosening of shoe bolts and the other various problems.

※ **Table 1**

Track shoe	Specification	Category
600 mm triple grouser	Standard	A
700 mm triple grouser	Option	B
800 mm triple grouser	Option	C
900 mm triple grouser	Option	C

※ **Table 2**

Category	Applications	Precautions
A	Rocky ground, river beds, normal soil	<ul style="list-style-type: none"> • Travel at low speed on rough ground with large obstacles such as boulders or fallen trees
B	Normal soil, soft ground	<ul style="list-style-type: none"> • These shoes cannot be used on rough ground with large obstacles such as boulders or fallen trees • Travel at high speed only on flat ground • Travel slowly at low speed if it is impossible to avoid going over obstacles
C	Extremely soft ground (swampy ground)	<ul style="list-style-type: none"> • Use the shoes only in the conditions that the machine sinks and it is impossible to use the shoes of category A or B • These shoes cannot be used on rough ground with large obstacles such as boulders or fallen trees • Travel at high speed only on flat ground • Travel slowly at low speed if it is impossible to avoid going over obstacles

8. SPECIFICATIONS FOR MAJOR COMPONENTS

1) ENGINE

Item	Specification
Model	Cummins QSB6.7 / HYUNDAI HE 6.7
Type	4-cycle turbocharged diesel engine, low emission
Cooling method	Water cooling
Number of cylinders and arrangement	6 cylinders, in-line
Firing order	1-5-3-6-2-4
Combustion chamber type	Direct injection type
Cylinder bore × stroke	107 × 124 mm (4.2" × 4.9")
Piston displacement	6700 cc (409cu in)
Compression ratio	17.2 : 1
Rated gross horse power (SAE J1995)	151 Hp at 1900 rpm (113 kW at 1900 rpm)
Maximum torque at 1500 rpm	63.0 kgf · m (456 lbf · ft)
Engine oil quantity	24 l (6.3 U.S. gal)
Dry weight	556 kg (1226 lb)
High idling speed	1950 ± 50 rpm
Low idling speed	850 ± 100 rpm
Rated fuel consumption	167.8 g/Hp · hr at 1900 rpm
Starting motor	Nippon denso (24 V-4.5 kW)
Alternator	Delco Remy (24 V-70 A)
Battery	2 × 12 V × 100 Ah

2) MAIN PUMP

Item	Specification
Type	Variable displacement tandem axis piston pumps
Capacity	2 × 117cc/rev
Maximum pressure	350kgf/cm ² (4980psi) [380 kgf/cm ² (5400 psi)]
Rated oil flow	2 × 222 l /min (58.6U.S. gpm/ 48.8U.K. gpm)
Rated speed	1900 rpm

[] : Power boost

3) GEAR PUMP

Item	Specification
Type	Fixed displacement gear pump single stage
Capacity	15 cc/rev
Maximum pressure	40 kgf/cm ² (570 psi)
Rated oil flow	28.5 l /min (7.5 U.S. gpm/6.3 U.K. gpm)

4) MAIN CONTROL VALVE

Item	Specification	
Type	9 spools two-block	
Operating method	Hydraulic pilot system	
Main relief valve pressure	350 kgf/cm ² (4980 psi) [380 kgf/cm ² (5400 psi)]	
Port relief valve pressure	Boom	400 kgf/cm ² (5690 psi)
	Arm	400 kgf/cm ² (5690 psi)
	Bucket	400 kgf/cm ² (5690 psi)

[]: Power boost

5) SWING MOTOR

Item	Specification
Type	Two fixed displacement axial piston motor
Capacity	151 cc/rev
Relief pressure	285 kgf/cm ² (4050 psi)
Braking system	Automatic, spring applied hydraulic released
Braking torque	59 kgf · m (427 lbf · ft)
Brake release pressure	33~50 kgf/cm ² (470~711 psi)
Reduction gear type	2 - stage planetary

6) TRAVEL MOTOR

Item	Specification
Type	Variable displacement axial piston motor
Relief pressure	350 kgf/cm ² (4980 psi)
Reduction gear type	2-stage planetary
Braking system	Automatic, spring applied hydraulic released
Brake release pressure	11 kgf/cm ² (156 psi)
Braking torque	49.3 kgf · m (357 lbf · ft)

7) CYLINDER

Item		Specification
Boom cylinder	Bore dia × Rod dia × Stroke	∅ 120 × ∅ 85 × 1290 mm
	Cushion	Extend only
Arm cylinder	Bore dia × Rod dia × Stroke	∅ 140 × ∅ 100 × 1510 mm
	Cushion	Extend and retract
Bucket cylinder	Bore dia × Rod dia × Stroke	∅ 120 × ∅ 85 × 1055 mm
	Cushion	Extend only

※ Discoloration of cylinder rod can occur when the friction reduction additive of lubrication oil spreads on the rod surface.

※ Discoloration does not cause any harmful effect on the cylinder performance.

8) SHOE

Item		Width	Ground pressure	Link quantity	Overall width
R235LCR-9	Standard	600 mm (24")	0.51 kgf/cm ² (7.25 psi)	49	2990 mm (9' 10")
	Option	700 mm (28")	0.44 kgf/cm ² (6.26 psi)	49	3090 mm (10' 2")
		800 mm (32")	0.39 kgf/cm ² (5.55 psi)	49	3190 mm (10' 6")
		900 mm (36")	0.35 kgf/cm ² (4.98 psi)	49	3290 mm (10' 10")

9) BUCKET

Item	Capacity		Tooth quantity	Width	
	SAE heaped	CECE heaped		Without side cutter	With side cutter
R235LCR-9	0.51 m ³ (0.67 yd ³)	0.45 m ³ (0.59 yd ³)	3	700 mm (27.6")	820 mm (32.3")
	0.80 m ³ (1.05 yd ³)	0.70 m ³ (0.92 yd ³)	5	1000 mm (39.4")	1120 mm (44.1")
	0.87 m ³ (1.14 yd ³)	0.75 m ³ (0.98 yd ³)	5	1090 mm (42.9")	1120 mm (47.6")
	0.92 m ³ (1.20 yd ³)	0.80 m ³ (1.05 yd ³)	5	1150 mm (45.3")	1270 mm (50.0")
	1.10 m ³ (1.44 yd ³)	0.96 m ³ (1.26 yd ³)	5	1320 mm (52.0")	1440 mm (56.7")
	1.20 m ³ (1.57 yd ³)	1.00 m ³ (1.31 yd ³)	5	1400 mm (55.1")	1520 mm (60.0")
	1.34 m ³ (1.75 yd ³)	1.15 m ³ (1.50 yd ³)	6	1550 mm (61.0")	1670 mm (65.7")
	◆0.74 m ³ (0.97 yd ³)	0.65 m ³ (0.85 yd ³)	5	985 mm (38.8")	-
	◆0.90 m ³ (1.18 yd ³)	0.80 m ³ (1.05 yd ³)	5	1070 mm (42.1")	-
	◆1.05 m ³ (1.37 yd ³)	0.92 m ³ (1.20 yd ³)	5	1290 mm (50.8")	-
	◎0.87 m ³ (1.14 yd ³)	0.75 m ³ (0.98 yd ³)	5	1140 mm (44.9")	-
	■0.75 m ³ (0.98 yd ³)	0.65 m ³ (0.85 yd ³)	-	1790 mm (70.5")	-

◆ : Heavy duty bucket

◎ : Rock bucket

■ : Slope finishing bucket

9. RECOMMENDED OILS

Use only oils listed below. Do not mix different brand oil.

Please use HYUNDAI genuine oil and grease.

Service point	Kind of fluid	Capacity ℓ (U.S. gal)	Ambient temperature °C (°F)						
			-50 (-58)	-30 (-22)	-20 (-4)	-10 (14)	0 (32)	10 (50)	20 (68)
Engine oil pan	Engine oil	24 (6.3)	★SAE 5W-40						
			SAE 30						
			SAE 10W						
			SAE 10W-30						
			SAE 15W-40						
Swing drive	Gear oil	5.0 (1.3) ^{★2} 6.2 (1.7)	★SAE 75W-90						
Final drive		5.8 × 2 (1.5 × 2)	SAE 80W-90						
Hydraulic tank	Hydraulic oil	Tank; 160 (42) System; 275 (73)	★ISO VG 15						
			ISO VG 32						
			ISO VG 46						
			ISO VG 68						
Fuel tank	Diesel fuel	320 (85)	★ASTM D975 NO.1						
			ASTM D975 NO.2						
Fitting (grease nipple)	Grease	As required	★NLGI NO.1						
			NLGI NO.2						
Radiator (reservoir tank)	Mixture of antifreeze and soft water ^{★1}	35 (9.2)	Ethylene glycol base permanent type (50 : 50)						
			★Ethylene glycol base permanent type (60 : 40)						

SAE : Society of Automotive Engineers

API : American Petroleum Institute

ISO : International Organization for Standardization

NLGI : National Lubricating Grease Institute

ASTM : American Society of Testing and Material

★2 : Service when the grease inlet exists on the equipment

★1 : Soft water
City water or distilled water

★ : Cold region
Russia, CIS, Mongolia

SECTION 2 STRUCTURE AND FUNCTION

Group 1 Pump Device	2-1
Group 2 Main Control Valve	2-20
Group 3 Swing Device	2-47
Group 4 Travel Device	2-58
Group 5 RCV Lever	2-66
Group 6 RCV Pedal	2-73

This as a preview PDF file from best-manuals.com



Download full PDF manual at best-manuals.com