

CHALLENGER®
MT835C / MT845C / MT855C / MT865C / MT875C
Track Tractor
REPAIR TIME SCHEDULE
Form Number AG333729B

Contents

Section	Description
01	Basic Engine
02	Air Inlet and Exhaust System
03	Cooling System
04	Fuel System
05	Electrical and Starting System
06	Power Train
07	Power Train Attaching
08	Frame and Body
09	Differential Steering System
10	Undercarriage
11	Track Belts
12	Braking System
13	Hydraulic System
14	Drawbar, Threepoint Hitch & PTO
15	Operator Station
16	Markings
17	Service Equipment and Supplies

NOTE: This Repair Time Schedule (RTS) can be used with Repair Time Schedule storage binder supplied separately through the repair parts department.

BASIC ENGINE	SECTION 1
AIR INLET AND EXHAUST SYSTEM	SECTION 2
COOLING SYSTEM	SECTION 3
FUEL SYSTEM	SECTION 4
ELECTRICAL AND STARTING SYSTEM	SECTION 5
POWER TRAIN	SECTION 6
POWER TRAIN ATTACHING	SECTION 7
FRAME AND BODY	SECTION 8
DIFFERENTIAL STEERING SYSTEM	SECTION 9
UNDERCARRIAGE	SECTION 10
TRACK BELTS	SECTION 11
BRAKING SYSTEM	SECTION 12
HYDRAULIC SYSTEM	SECTION 13
DRAWBAR, THREEPOINT HITCH AND PTO	SECTION 14
OPERATOR STATION	SECTION 15
MARKINGS	SECTION 16
SERVICE EQUIPMENT AND SUPPLIES	SECTION 17

GENERAL INFORMATION

Contents

A. Time Allowance	iii
Example 1:	iv
Wheel Motor Failure	iv
Example 2:	iv
Transmission Replacement	iv
Example 3:	iv
Air Conditioning Receiver/Dryer Replacement (Catastrophic Failure)	iv
B. Times	v
C. Review of Times	v
D. Amendments	v
E. Request For Review of the Schedule	vi
F. Description of Symbols and Abbreviations	vii
G. Defect Code List	viii

A. TIME ALLOWANCE

The times listed in this publication are the result of careful study of the operation concerned; they represent the average time ONE trained Dealer mechanic, of normal ability has taken to carry out the operation in a typical Dealership, using standard workshop tooling and equipment, located for reasonable access and working conditions. They DO NOT include any travelling to or from the farm or site.

The machine is assumed to be clean and to be bare of any extra equipment or attachment of non AGCO manufacture, and delivered to an authorized and duly equipped workshop where trained personnel and spare parts required to perform the operations are immediately available.

The times given include difficulties encountered working on used as opposed to new machines, and are based on methods and recommended Special Tools shown in the workshop manual.

The times are based on a second hand machine in reasonable condition properly maintained using approved parts. Extra time may be required to deal with seized, rusted or damaged parts, which must be claimed for separately when carrying out warranty work.

Allowances are included in the operation times quoted for setting up the machine in the workshop, obtaining all tools and parts, cleaning and testing after repair.

Time required to remove and install mounted implements, such as loaders, hedge cutters, etc., which interfere with performing a specific job is NOT INCLUDED in the time allowed.

The times given in this Repair Time Schedule are for a complete job from start to finish, including allowances for intermediated operations.

GENERAL INFORMATION

EXAMPLE 1:

Wheel Motor Failure

Code	Hours	Part Description	Work Included
330205	4	Wheel Motor Seal Remove and Replace	With a supported unit, remove tire and rim. Remove and replace seal. Reinstall tire and rim. Lower Unit. Test drive unit.

EXAMPLE 2:

Transmission Replacement

Code	Hours	Part Description	Work Included
140100	1	Diagnose Electrical	Support unit. Remove and replace lower unit.
192678	A/R	System Flush	Test drive.

EXAMPLE 3:

Air Conditioning Receiver/Dryer Replacement (Catastrophic Failure)

Code	Hours	Part Description	Work Included
150111	0.5	Replace	Diagnosis
150123	3	Reclaiming/ Recharging/Diagnosis	Evaluate Replace Recharge Test

NOTE: Times can only be added if the appropriate Special Codes is identified on the RTS page as the casual part.

B. TIMES

All the operation times are presented in hours and the decimal parts of an hour. Decimal times must be used on all warranty claims. A chart is provided below so that time can be converted.

Min.	0	1	2	3	4	5	6	7	8	9
0	--	0.02	0.03	0.05	0.07	0.08	0.10	0.12	0.13	0.15
10	0.17	0.18	0.20	0.22	0.23	0.25	0.27	0.28	0.30	0.32
20	0.33	0.35	0.37	0.38	0.40	0.42	0.43	0.45	0.47	0.48
30	0.50	0.52	0.53	0.55	0.57	0.88	0.60	0.62	0.63	0.65
40	0.67	0.68	0.70	0.72	0.73	0.75	0.77	0.78	0.80	0.82
50	0.83	0.85	0.87	0.88	0.90	0.92	0.93	0.95	0.97	0.98

The times given in this repair time schedule are for a complete job from start to finish. Where access has been gained for an adjacent repair only the additional time for the second repair will be accepted and not the total time for the two failures.

The Term ADD indicates that the time may be added to the main repair time if required, e.g., diagnosis time, pressure testing.

C. REVIEW OF TIMES

If you find any improvement in method which reduces the time of an operation or if you find you cannot meet an operation time after more than three attempts using the recommended method, a Request of Time Change form (next page) must be submitted quoting all relevant details. Photo copy the form and send it to the following address:

AGCO Corporation

Attn: Application Equipment Product Reliability

202 Industrial Park

Jackson, Mn 56143

Or Fax: 507-847-3334

These requests will not be actioned unless the information asked for is provided in full, on the form provided. Any amendments will be advised by Service Bulletin.

D. AMENDMENTS

All times contained in this schedule are based on the latest information available at the time of publication. The right is reserved to publish revisions at any time. All operation times are subject to amendment if design, method or technique changes result in alteration of time taken.

GENERAL INFORMATION

E. REQUEST REVIEW OF SCHEDULE

Request for review of time schedule

Distributor Name..... Date.....

Address.....

RTS Publication No..... Failure code No.....

Machine Model..... Serial No.....

We wish to query your time allowance against the above failure code number and confirm that we have observed and accurately timed this operation as carried out by a trained mechanic using recommended procedures and special tools, our findings are detailed below:

Analysis of Time		
Work Performed	Time	Remarks
Remove component		
Dismantle		
Clean and inspect		
Obtain parts and tools		
Reassemble		
Reinstall		
Adjust and test		
TOTAL OF TIME		
Number of mechanics used on job		

Signed..... Name.....

Post to:

AGCO Corporation
Attn: Application Equipment Product Reliability
202 Industrial Park
Jackson, MN 56143
or Fax: 507-847-3334

N032802001

FIG. 1

F. DESCRIPTION OF SYMBOLS AND ABBREVIATIONS

FIG. 2: Symbol descriptions:

- (1) Failure Code
- (2) Time
- (3) Service Tool
- (4) Recharging Air Conditioning
- (5) Adjustment Only
- (6) Bleeding
- (7) Hydraulic Tests
- (8) Electrical Diagnosis
- (9) Paint Work
- (10) Use of Special Tool
- (11) Additional Labor

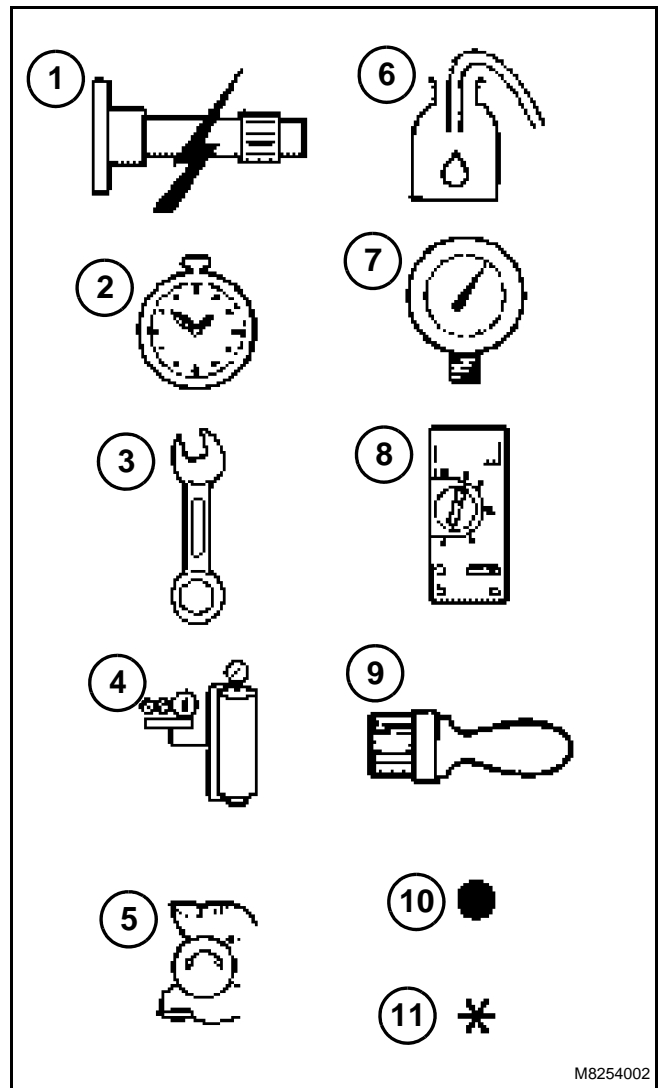

M8254002

FIG. 2

GENERAL INFORMATION

G. DEFECT CODE LIST

Code	Definition
10	Leakage
14	Misted up, Foggy
15	Sticks
16	Slipping
17	Noisy
18	Surface rust, Oxidation
19	Improper finish application
20	Weathered
22	Missing
23	Incorrect torque
24	Incorrect timing
25	Loose
26	Incorrect assembly
30	Circuit fault, Signal
31	Short circuit, Earth short
33	Incorrectly programmed
34	Ambient temperature sensitive
45	Inadequate performance
46	Oil consumption
47	Fuel consumption
48	Bulge damage
60	Improper display contrast
61	Character missing in display
65	Cavitation
70	Fractured, Broken
71	Bent
72	Burst, Split
73	Seized
74	Worn
75	Burnt, Charred
76	Corroded, pitting
95	Modification campaign
99	Service contract

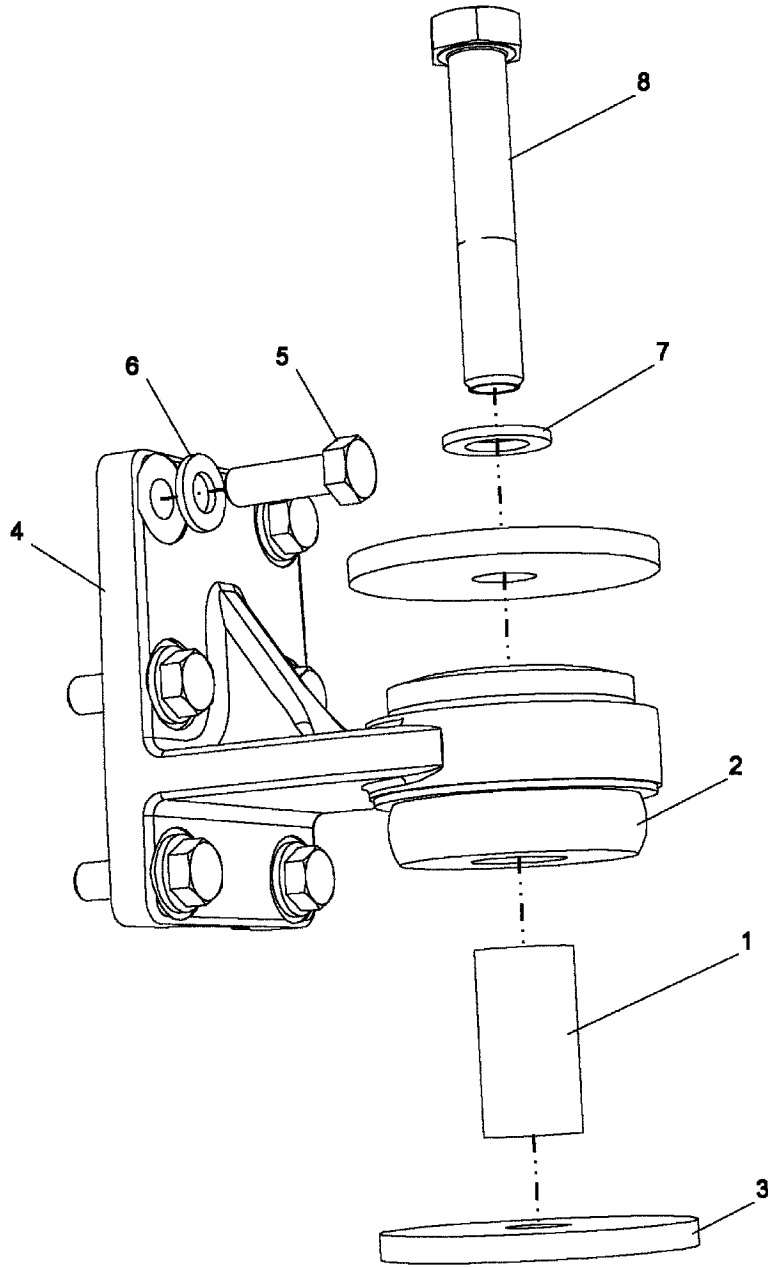

MOUNTING GROUP-ENGINE	1-1
PULLEY GROUP	1-2
DRIVE GROUP - FAN	1-3
DRIVE GROUP-ACCESSORY	1-4
MOUNTING GROUP-COMPRESSOR	1-5
COMPRESSOR GROUP - CLUTCH	1-6
AID GROUP-ETHER STARTING	1-7
MOUNTING GROUP-ALTERNATOR	1-8
LINES GROUP- A/C	1-9
LINES GROUP- A/C	1-10
TANK GROUP-AIR,MT800	1-11
TANK GROUP-AIR,MT800	1-12
COMPRESSOR GROUP-AIR	1-13
COMPRESSOR GROUP-AIR	1-14
COMPRESSOR GROUP-AIR	1-15
COUPLING GROUP-ENGINE DRIVE COUPLER	1-16



172-5333-05-N956-.TIF

BASIC ENGINE

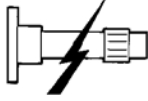

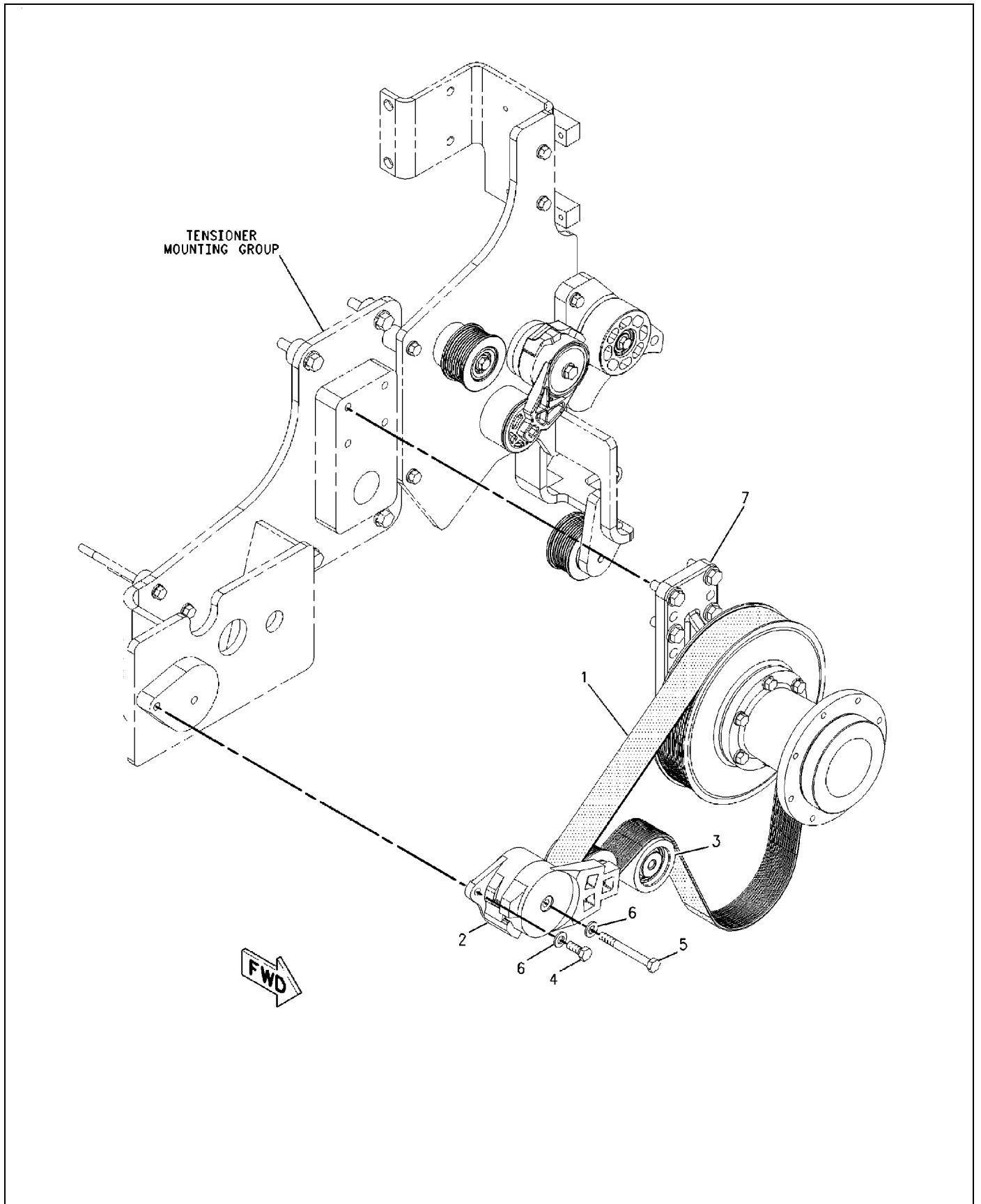

				MOUNTING GROUP-ENGINE
2	58 39 03	3.00		MOUNT AS
4	58 39 05	2.00		SUPPORT-ENGINE (REAR)



185-2240-04-T065-.TIF

BASIC ENGINE

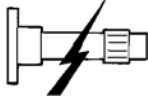

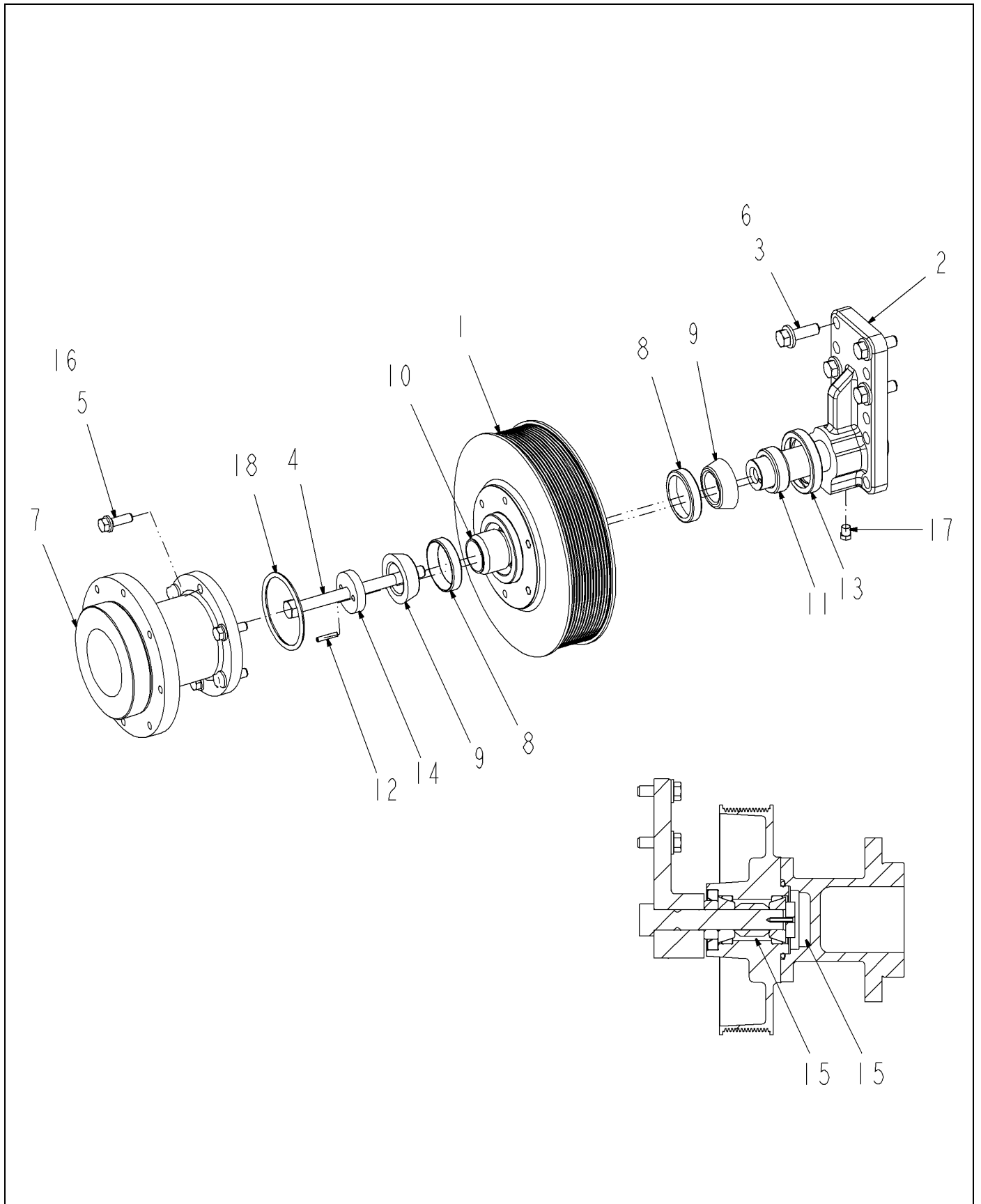

				PULLEY GROUP
1	59 07 00	2.00		BELT (14K)
2	59 22 03	2.50		TIGHTENER - BELT
3	59 22 02	2.00		PULLEY AS.-IDLER
7	59 06 00	4.00		DRIVE GP - FAN



523744D1-01-T065-.TIF

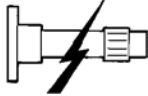

BASIC ENGINE

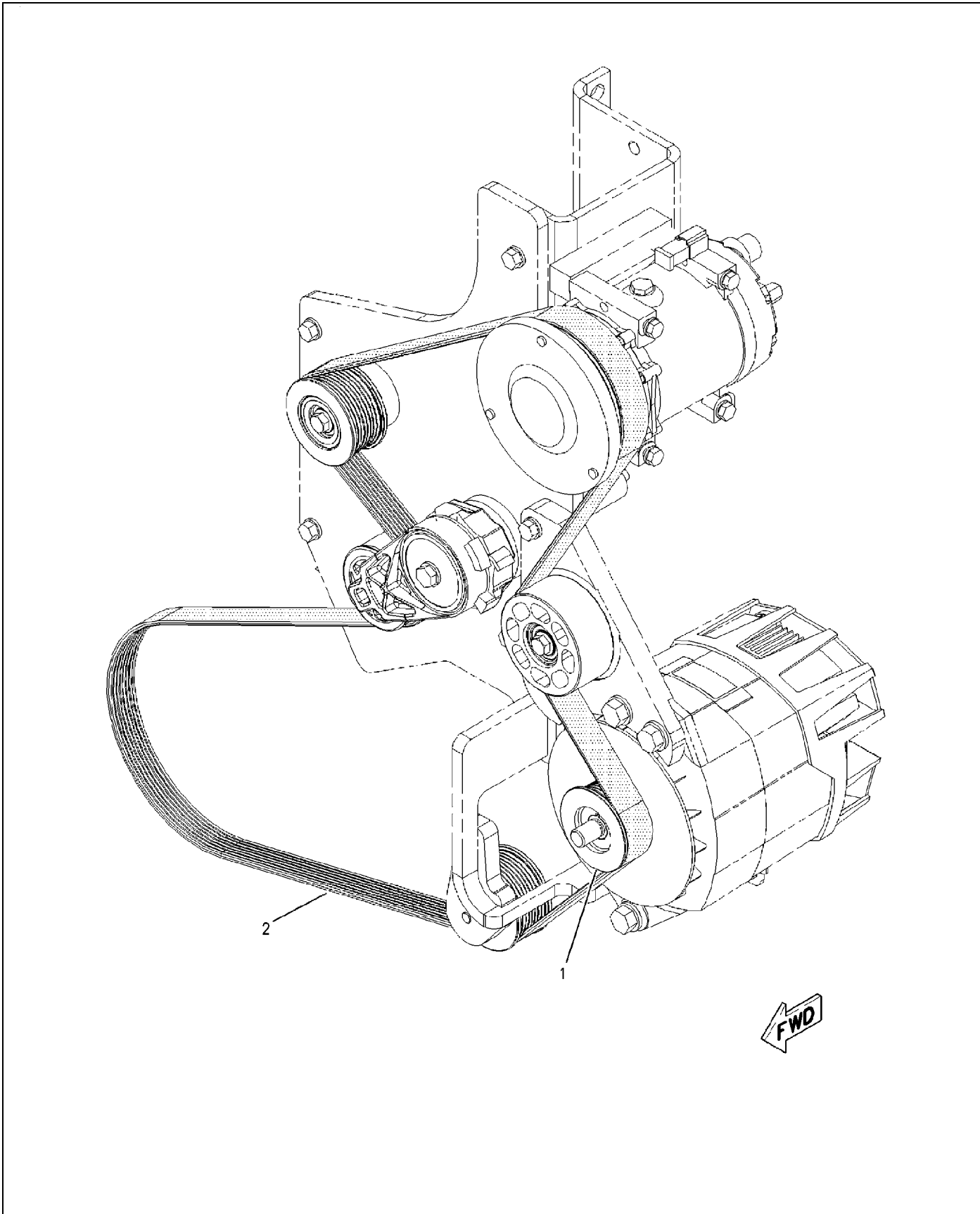

				DRIVE GROUP - FAN
1	59 22 00	5.00		PULLEY FAN
2	59 22 08	5.00		BRACKET AS
7	59 22 04	5.00		ADAPTER-FAN
8	59 22 05	5.00		CUP-BRG TAP RLR 59.9 OD
9	59 22 05	5.00		CONE-BRG TAP RLR 34.9 ID
13	59 22 09	5.00		SEAL-PIN 50.80IDX72.11ODX11.89
14	59 22 07	5.00		PLATE



187-1791-06-T848-.TIF

BASIC ENGINE

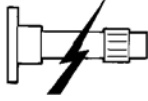

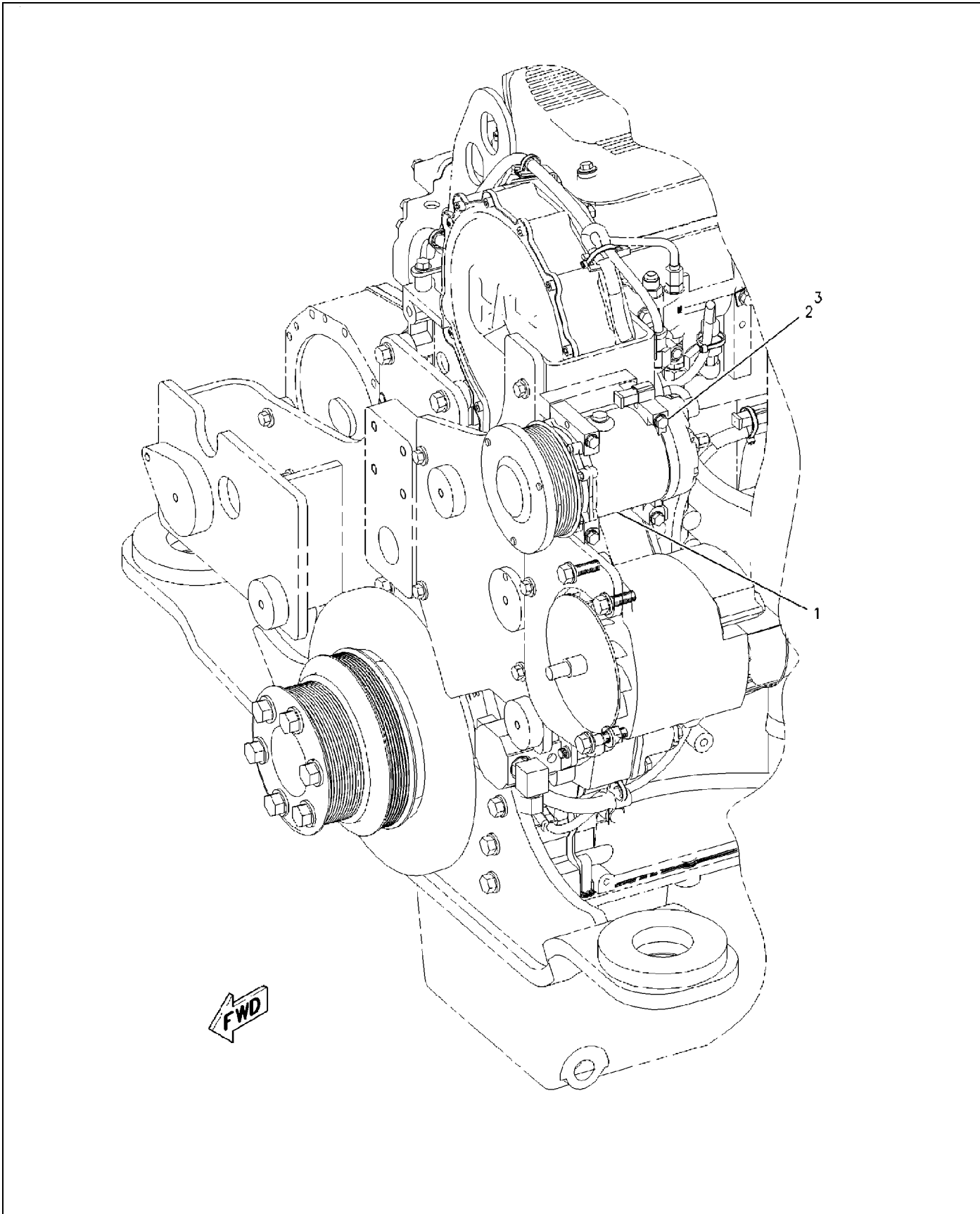

				DRIVE GROUP-ACCESSORY
1	15 01 18	2.00		PULLEY
2	59 07 00	2.00		BELT(8K)



187-1792-02-.TIF

BASIC ENGINE



				MOUNTING GROUP-COMPRESSOR
1	15 01 12	4.00		COMPRESSOR GP - CLUTCH

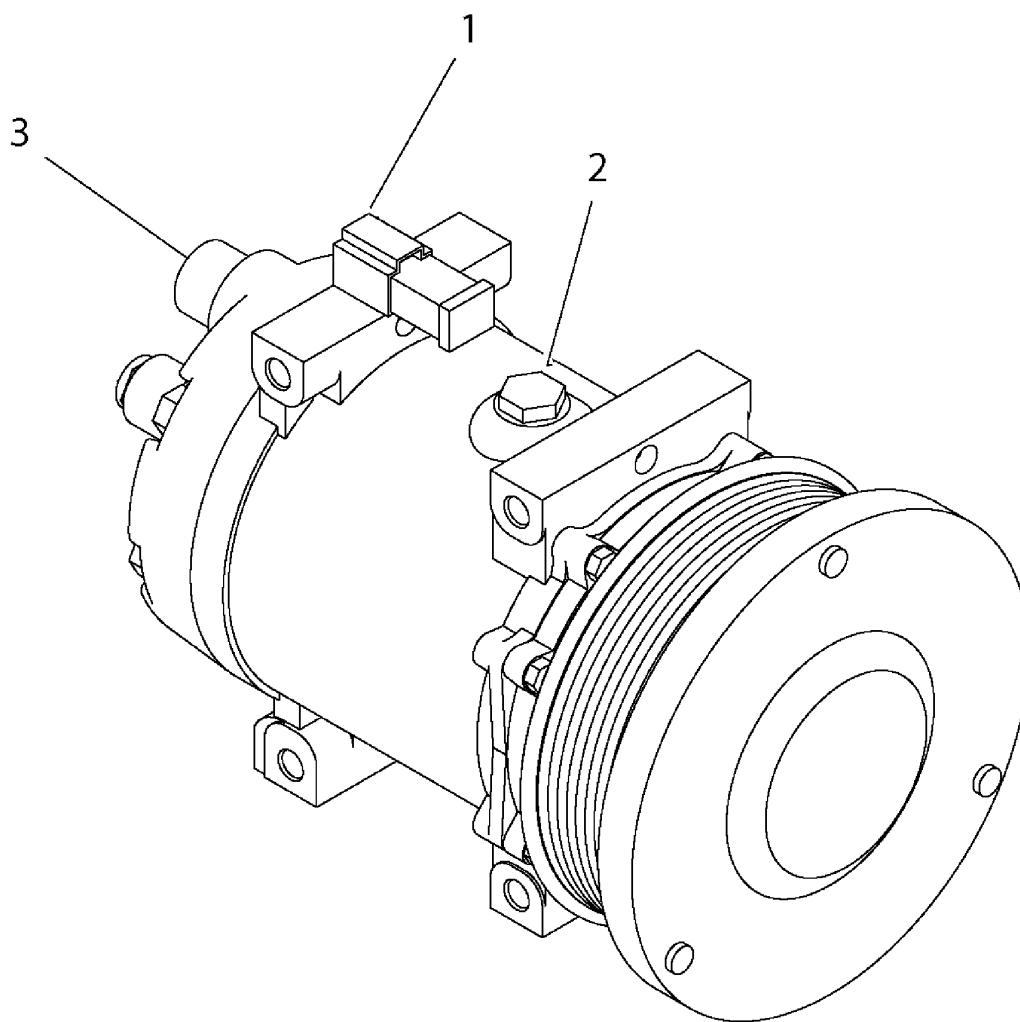

CH178-9570-02-K921-.tif

BASIC ENGINE



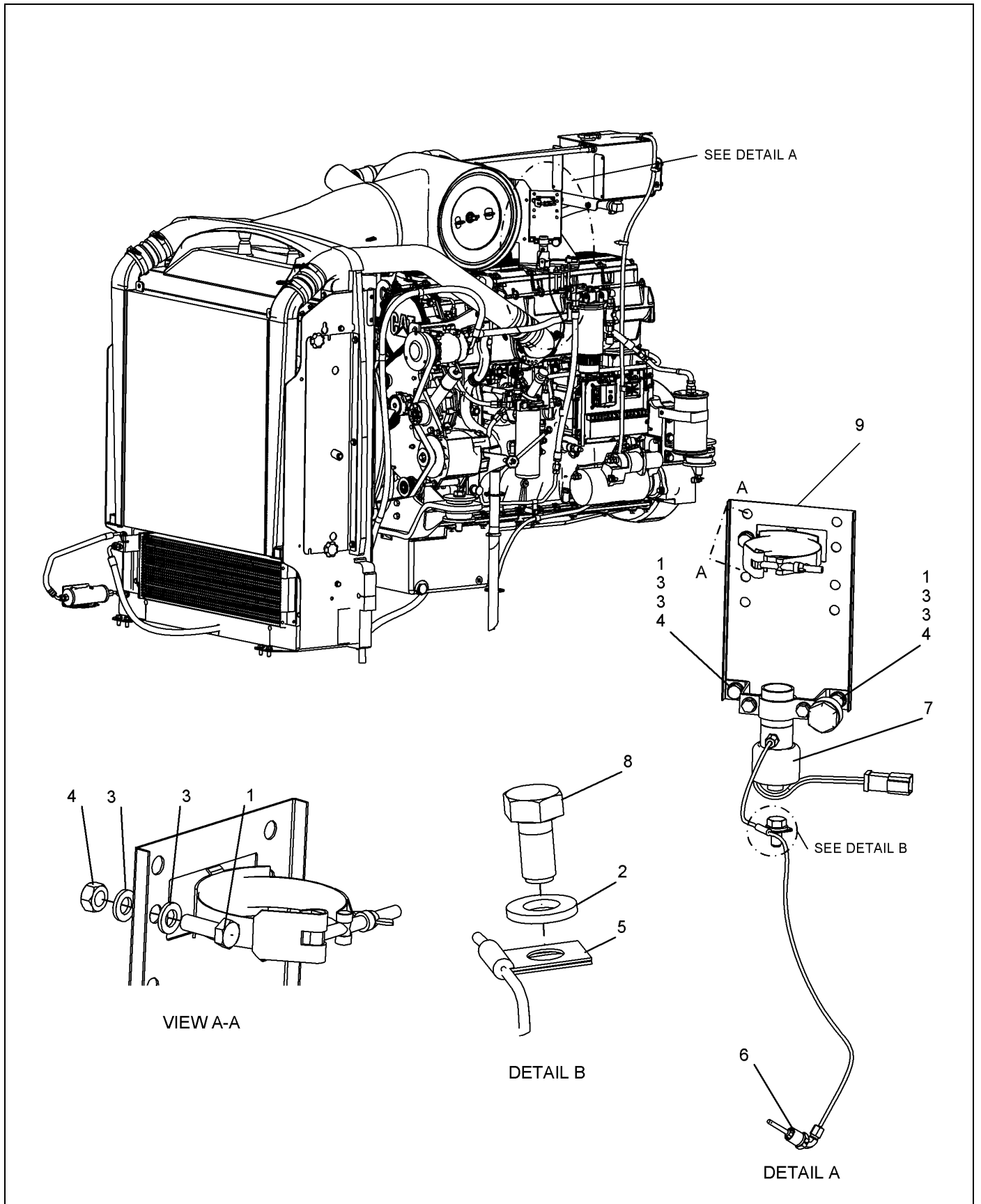

	A technical drawing of a clutch assembly with a lightning bolt symbol over it, indicating it is a replacement part.	A stopwatch icon, indicating a timing specification.	An open-end wrench icon, indicating a torque specification.	COMPRESSOR GROUP - CLUTCH
3	58 65 68	0.50		VALVE-PRESSURE RELIEF W/O-RING



501572D1-01--.TIF

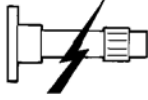

BASIC ENGINE



				AID GROUP-ETHER STARTING
6	14 16 28	1.50		ATOMIZER AS
7	14 16 30	1.50		VALVE GP-ETHER
9	14 16 29	2.00		MOUNTING GP - ETHER

BASIC ENGINE

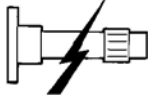

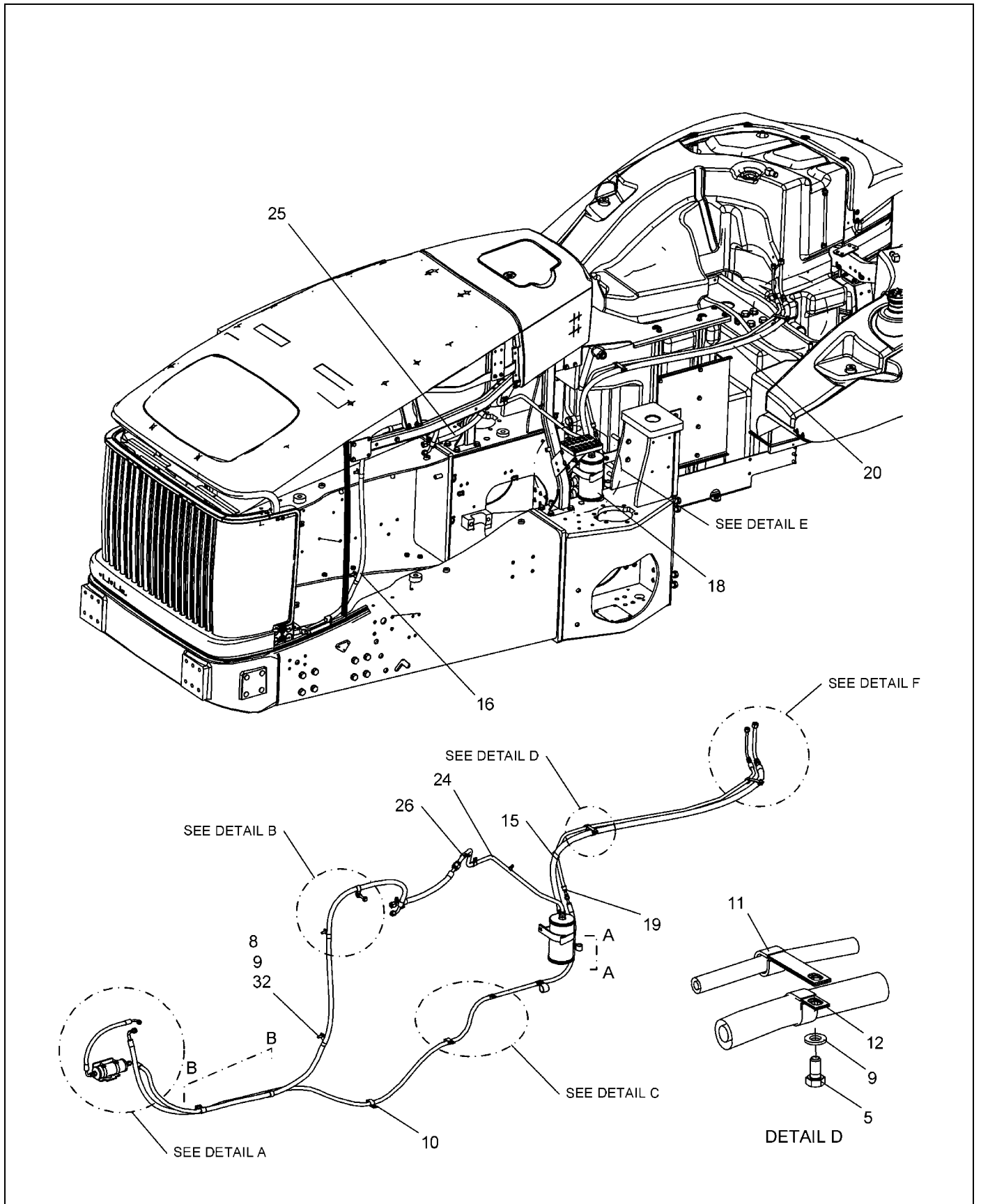

				MOUNTING GROUP-ALTERNATOR
1	14 01 98	1.20		BRACKET
6	14 01 02	2.00		ALTERNATOR - 12 VOLTS 185 AMPS



522430D1-07-W689-01.TIF

BASIC ENGINE

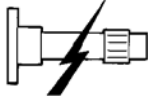

				LINES GROUP- A/C
8	58 29 80	0.75		CLAMP-HOSE CT SST 57-79X16
15	15 03 17	3.00		HOSE AS. (FOR
16	15 01 11	0.50		RECEIVER/DRYER
18	15 03 11	5.00		TUBE ASM (R134A) -10
19	15 03 11	5.00		ACCUMULATOR (R-134A)
20	15 03 17	3.00		HOSE ASM A/C (R134A)-6
24	15 03 13	8.00		HOSE ASM A/C (R134A)-6

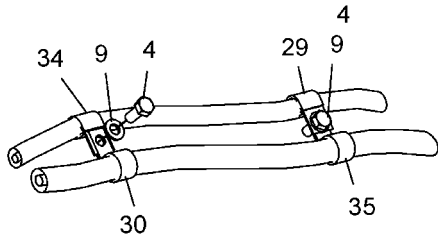

VIEW B-B

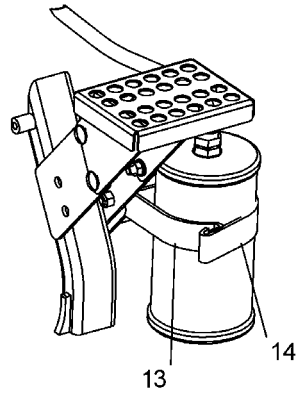

DETAIL E

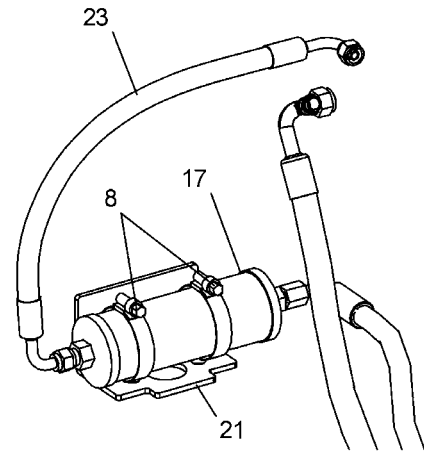

DETAIL A

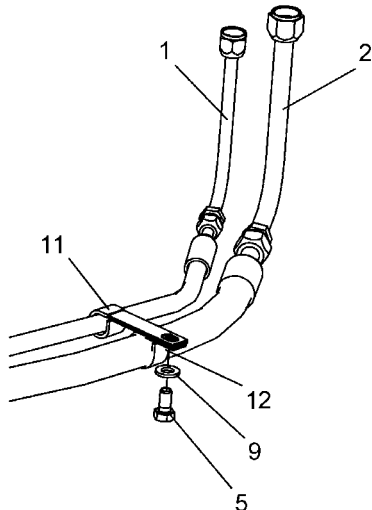

DETAIL F

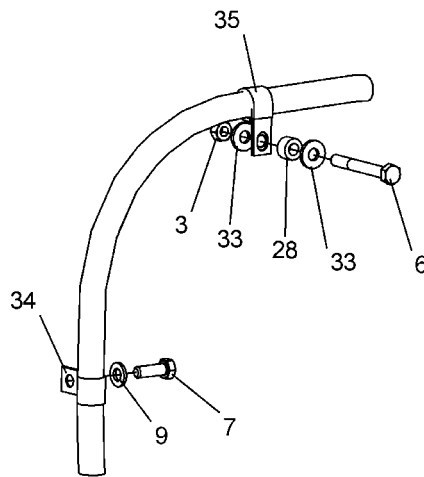

DETAIL B

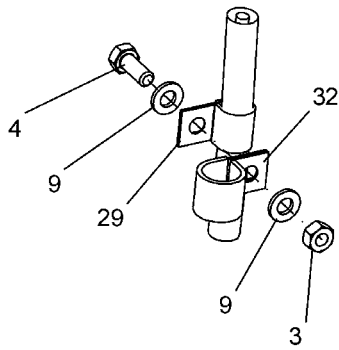

VIEW A-A

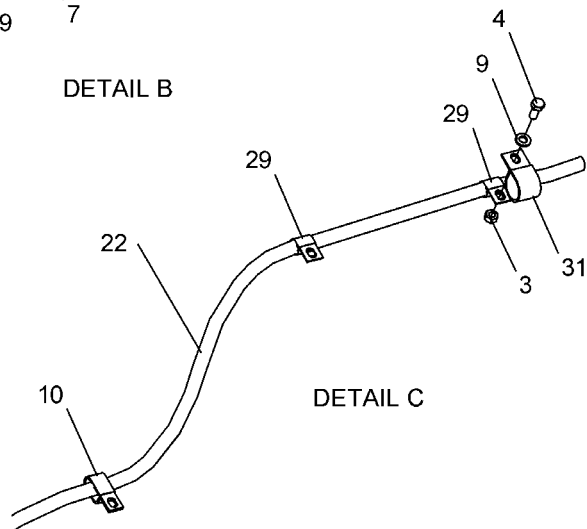



DETAIL C

522430D1-07-W689-02.TIF

BASIC ENGINE

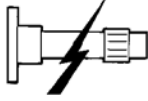

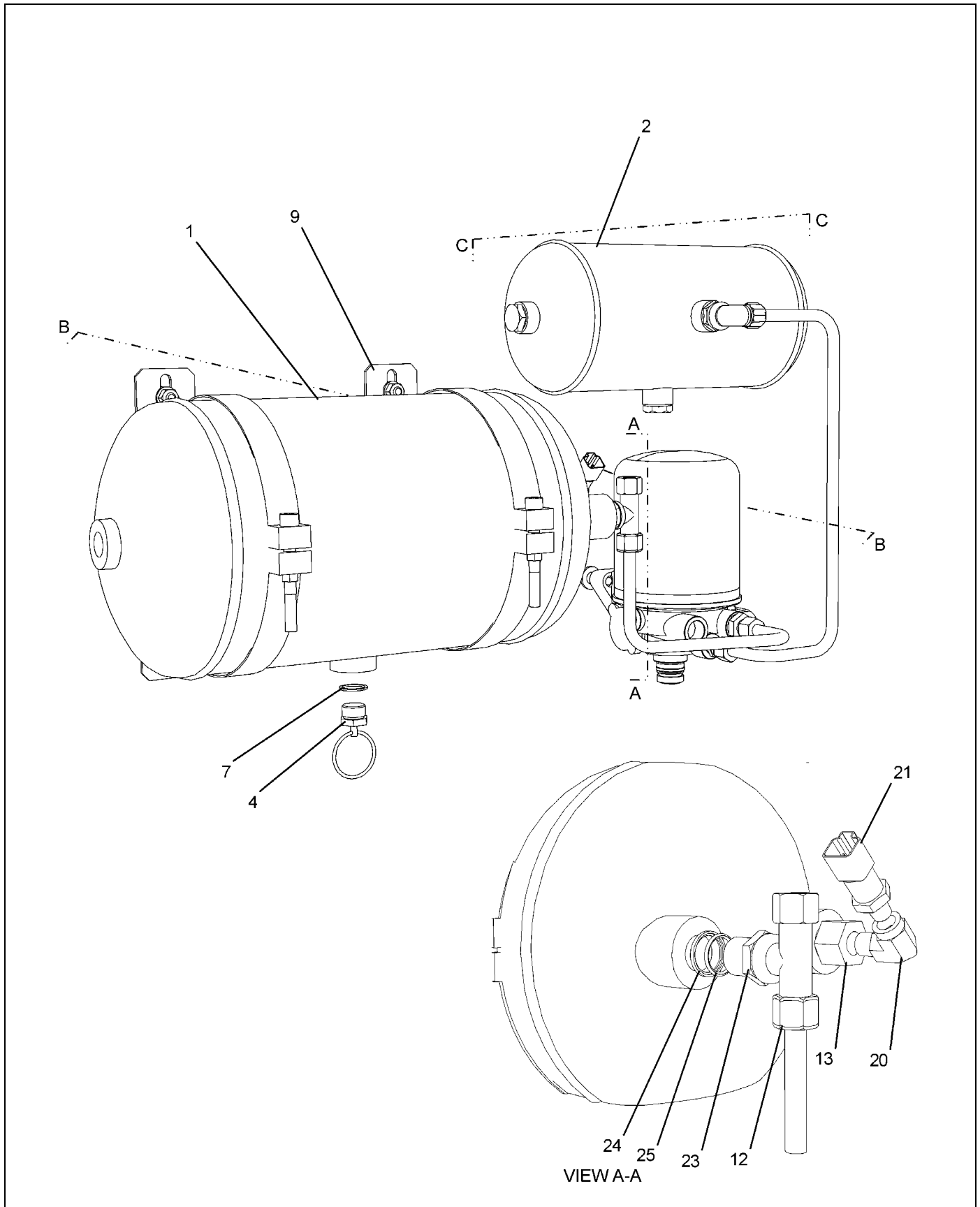

				LINES GROUP- A/C
1	15 03 15	5.00		TUBE AS
2	15 03 11	5.00		TUBE AS
8	58 29 80	0.75		CLAMP-HOSE CT SST 57-79X16
17	15 03 17	3.00		HOSE ASM A/C (R134A)-12
21	15 03 13	8.00		HOSE ASM A/C (R134A)-14
23	15 03 13	8.00		HOSE ASM A/C (R134A)-6



528409D1-04-V937-01.TIF

BASIC ENGINE



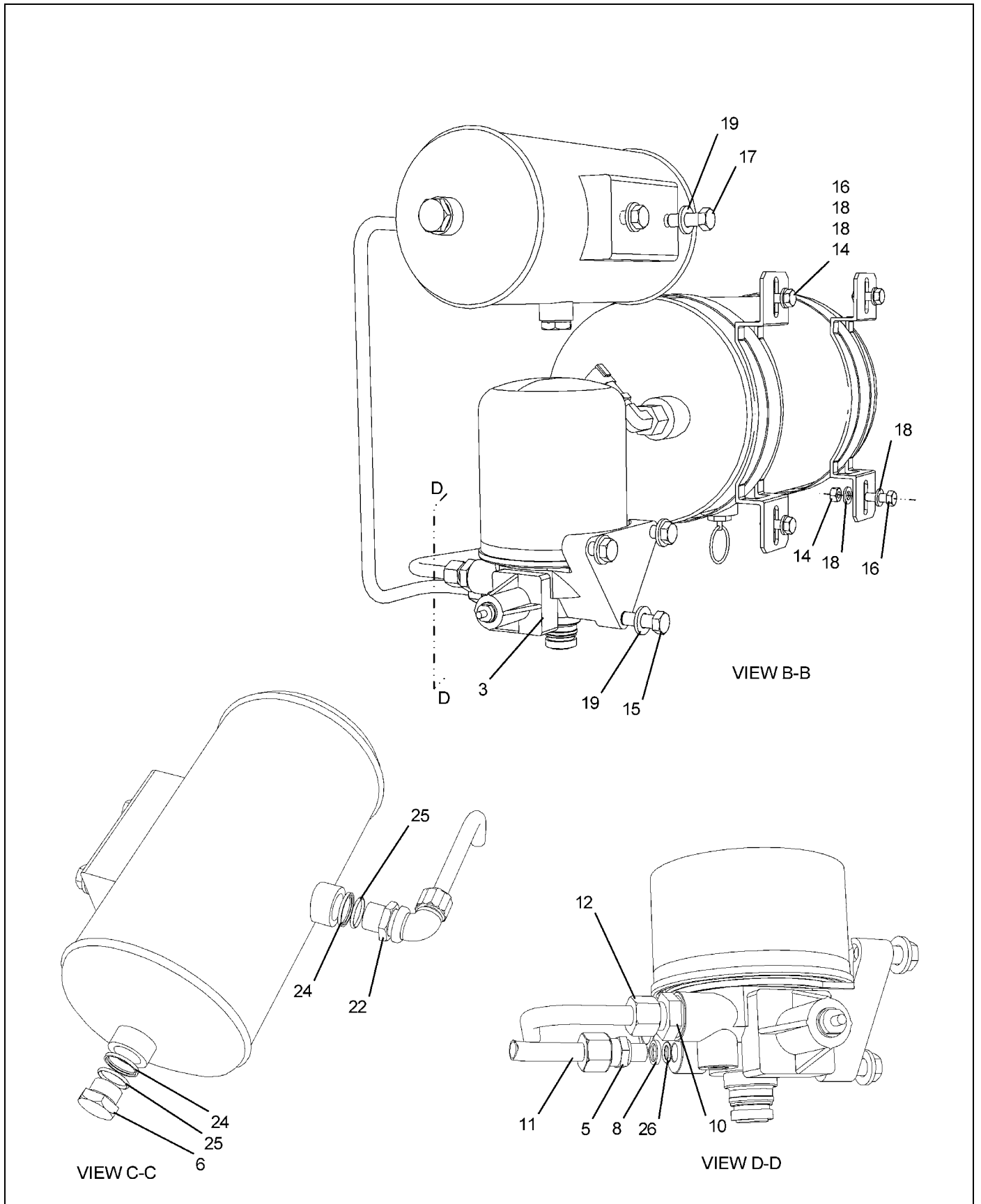

				TANK GROUP-AIR,MT800
1	26 03 41	2.00		TANK-RESERVOIR
2	26 03 42	2.00		TANK-RESERVOIR
4	26 03 44	1.00		VALVE-DRAIN
12	26 03 47	1.50		TUBE AS.
13	26 05 11	2.50		ADPTR STR M22-1.5 OR X0.37FNPT
20	26 05 05	1.00		ELBOW-90DEG 6NPTM X 4NPTF
21	14 18 86	1.00		SENSOR-PRESSURE,AIR
23	26 05 07	1.20		TEE-M18 X M22 X M18



528409D1-04-V937-02.TIF

BASIC ENGINE

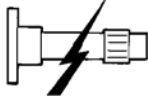

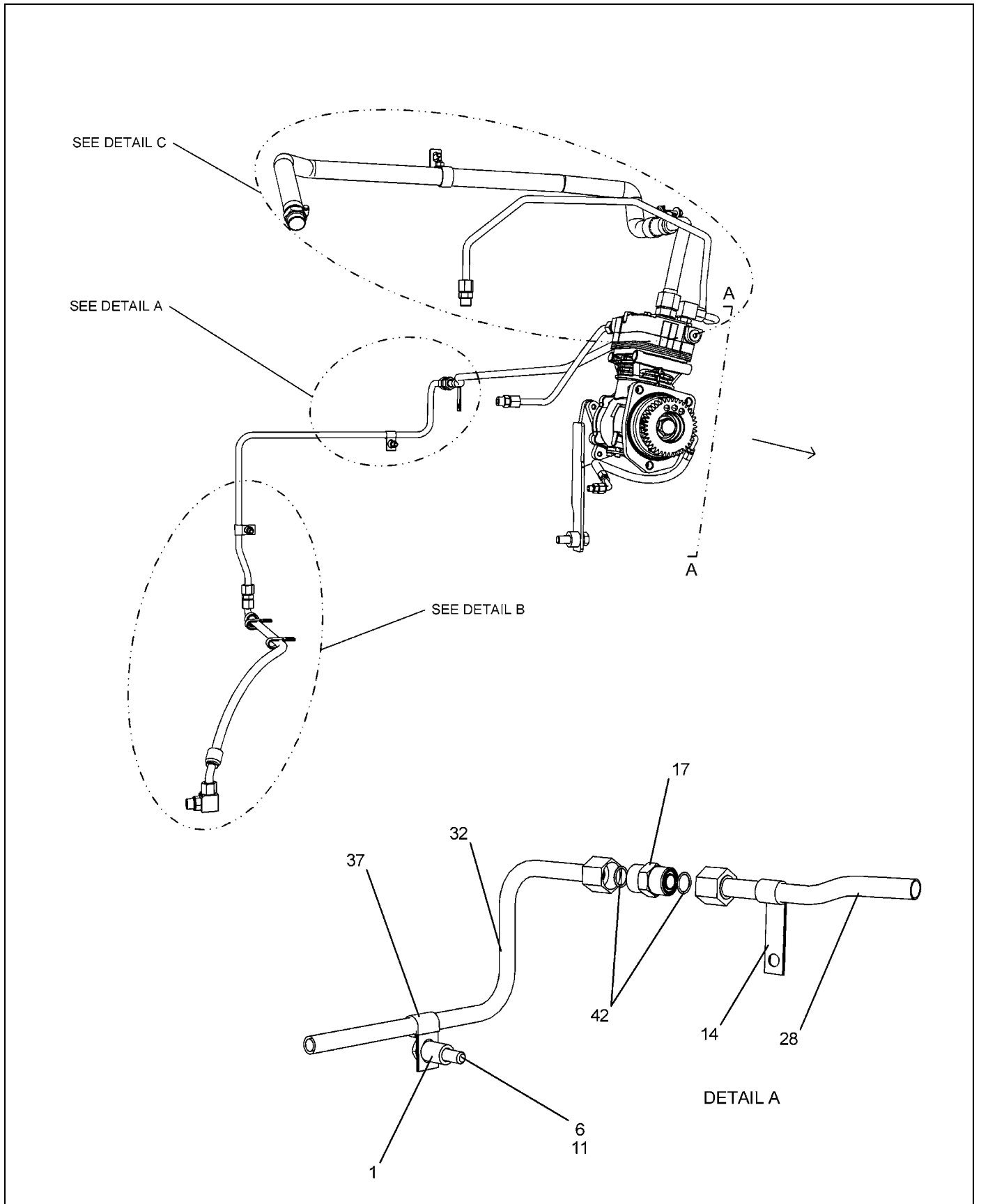

				TANK GROUP-AIR,MT800
3	26 03 43	1.50		DRYER GP-AIR (B)
6	26 03 45	0.80		PLUG
11	26 03 46	2.50		TUBE AS.
12	26 03 47	1.50		TUBE AS.



501600D1-10-W851-01.TIF

BASIC ENGINE

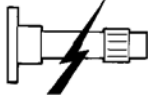

				COMPRESSOR GROUP-AIR
17	58 65 64	0.50		UNION- 10 ORFS
32	58 65 71	1.00		TUBE AS.

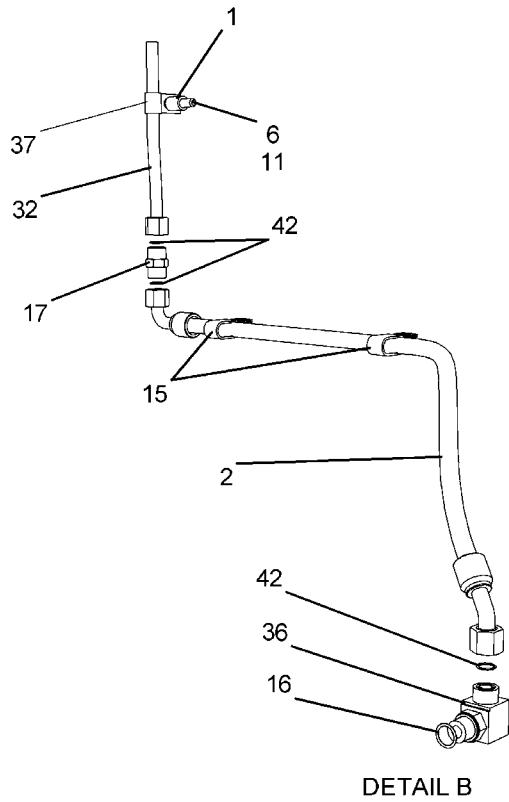

DETAIL B

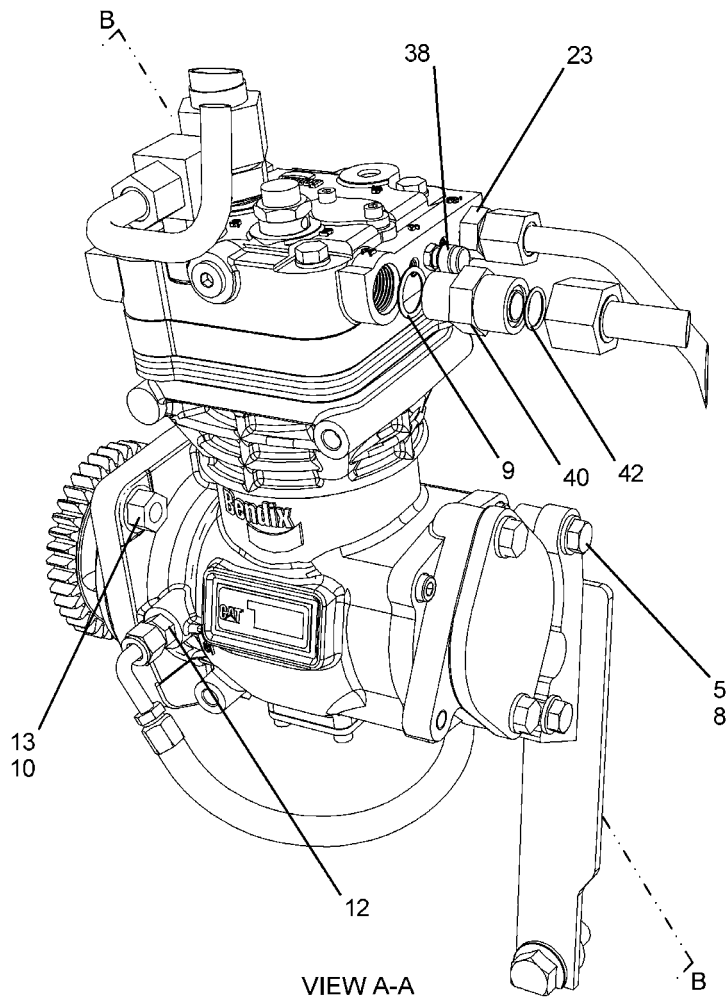

VIEW A-A

501600D1-10-W851-02.TIF

This as a preview PDF file from best-manuals.com



Download full PDF manual at best-manuals.com