



**HYUNDAI**  
**CONSTRUCTION EQUIPMENT**

**HL940A**  
**WHEELED LOADER**

**HL940A**



**SERVICE MANUAL**

# TABLE OF CONTENT

<b>CONTENTS</b> . . . . .	<b>2</b>
<b>FOREWORD</b> . . . . .	<b>4</b>
<b>SECTION 1 GENERAL</b> . . . . .	<b>12</b>
Group 1 Safety Hints . . . . .	13
Group 2 Specification . . . . .	22
Group 3 Operational Checkout Record Sheet . . . . .	39
<b>SECTION 2 ENGINE</b> . . . . .	<b>42</b>
Group 1 Structure And Function . . . . .	43
Group 2 Engine Speed & Stall Rpm . . . . .	53
Group 3 Fuel Warmer System . . . . .	54
<b>SECTION 3 POWER TRAIN SYSTEM</b> . . . . .	<b>55</b>
Group 1 Structure And Function . . . . .	56
Group 2 Operational Checks And Troubleshooting . . . . .	132
Group 3 Tests And Adjustments . . . . .	144
Group 4 Disassembly And Assembly . . . . .	146
<b>SECTION 4 BRAKE AND FAN SYSTEM</b> . . . . .	<b>315</b>
Group 1 Structure And Function . . . . .	316
Group 2 Operational Checks And Troubleshooting . . . . .	347
Group 3 Tests And Adjustments . . . . .	354
Group 4 Disassembly And Assembly . . . . .	356
<b>SECTION 5 STEERING SYSTEM</b> . . . . .	<b>376</b>
Group 1 Structure And Function . . . . .	377
Group 2 Operational Checks And Troubleshooting . . . . .	384
Group 3 Tests And Adjustments . . . . .	390
Group 4 Disassembly And Assembly . . . . .	395
<b>SECTION 6 WORK EQUIPMENT</b> . . . . .	<b>422</b>
Group 1 Structure And Function . . . . .	423
2. Hydraulic Circuit (HI940a, HI940a Xt) . . . . .	424
Hydraulic Circuit (HI940a Tm) . . . . .	425
Group 2 Operational Checks And Troubleshooting . . . . .	462
Group 3 Tests And Adjustments . . . . .	472
Group 4 Disassembly And Assembly . . . . .	484
<b>SECTION 7 ELECTRICAL SYSTEM</b> . . . . .	<b>501</b>
Group 1 Component Location . . . . .	501
Group 2 Electrical Circuit . . . . .	503
Memorandum . . . . .	507
Group 4 Electrical Component Specification . . . . .	574
Group 5 Connectors . . . . .	581
Group 6 Troubleshooting . . . . .	604

## SECTION 1 GENERAL

Group 1 Safety Hints .....	1-1
Group 2 Specifications .....	1-10
Group 3 Operational Checkout Record Sheet .....	1-27

## SECTION 2 ENGINE

Group 1 Structure and Function .....	2-1
Group 2 Engine speed and Stall rpm .....	2-11
Group 3 Fuel Warmer System .....	2-12

## SECTION 3 POWER TRAIN SYSTEM

Group 1 Structure and Function (fault code) .....	3-1
Group 2 Operational Checks and Troubleshooting .....	3-75
Group 3 Test and Adjustments .....	3-86
Group 4 Disassembly and Assembly .....	3-88

## SECTION 4 BRAKE SYSTEM

Group 1 Structure and Function .....	4-1
Group 2 Operational Checks and Troubleshooting .....	4-32
Group 3 Tests and Adjustments .....	4-39
Group 4 Disassembly and assembly .....	4-41

## SECTION 5 STEERING SYSTEM

Group 1 Structure and Function .....	5-1
Group 2 Operational Checks and Troubleshooting .....	5-8
Group 3 Tests and Adjustments .....	5-14
Group 4 Disassembly and Assembly .....	5-20

## SECTION 6 WORK EQUIPMENT

Group 1 Structure and Function .....	6-1
Group 2 Operational Checks and Troubleshooting .....	6-38
Group 3 Tests and Adjustments .....	6-47
Group 4 Disassembly and Assembly .....	6-59

## SECTION 7 ELECTRICAL SYSTEM

Group 1 Component Location .....	7-1
Group 2 Electrical Circuit .....	7-3
Group 3 Monitoring System .....	7-22
Group 4 Electrical Component Specification .....	7-72
Group 5 Connectors .....	7-79
Group 6 Troubleshooting .....	7-100

## 1. STRUCTURE

This service manual has been prepared as an aid to improve the quality of repairs by giving the serviceman an accurate understanding of the product and by showing him the correct way to perform repairs and make judgements. Make sure you understand the contents of this manual and use it to full effect at every opportunity.

This service manual mainly contains the necessary technical information for operations performed in a service workshop.

For ease of understanding, the manual is divided into the following sections.

### **Structure and function**

This group explains the structure and function of each component. It serves not only to give an understanding of the structure, but also serves as reference material for troubleshooting.

### **Operational checks and troubleshooting**

This group explains the system operational checks and troubleshooting charts correlating problem to remedy.

### **Tests and adjustments**

This group explains checks to be made before and after performing repairs, as well as adjustments to be made at completion of the checks and repairs.

### **Disassembly and assembly**

This section explains the order to be followed when removing, installing, disassembling or assembling each component, as well as precautions to be taken for these operations.

The specifications contained in this shop manual are subject to change at any time and without any advance notice. Contact your HD Hyundai Construction Equipment distributor for the latest information.

## 2. HOW TO READ THE SERVICE MANUAL

### Distribution and updating

Any additions, amendments or other changes will be sent to HD Hyundai Construction Equipment distributors.

Get the most up-to-date information before you start any work.

### Filing method

1. See the page number on the bottom of the page.

File the pages in correct order.

2. Following examples shows how to read the page number.

Example 1

3 - 3

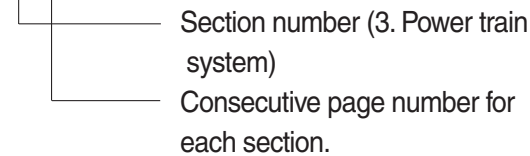

3. Additional pages : Additional pages are indicated by a hyphen(-) and number after the page number. File as in the example.

10 - 4

10 - 4 - 1

10 - 4 - 2

10 - 5

} Added pages

### Revised edition mark (①②③···)

When a manual is revised, an edition mark is recorded on the bottom outside corner of the pages.

### Revisions

Revised pages are shown at the list of revised pages on the between the contents page and section 1 page.

### Symbols

So that the shop manual can be of ample practical use, important places for safety and quality are marked with the following symbols.

Symbol	Item	Remarks
	Safety	Special safety precautions are necessary when performing the work.
		Extra special safety precautions are necessary when performing the work because it is under internal pressure.
	Caution	Special technical precautions or other precautions for preserving standards are necessary when performing the work.

### 3. CONVERSION TABLE

Method of using the Conversion Table

The Conversion Table in this section is provided to enable simple conversion of figures. For details of the method of using the Conversion Table, see the example given below.

#### Example

1. Method of using the Conversion Table to convert from millimeters to inches

Convert 55 mm into inches.

- (1) Locate the number 50 in the vertical column at the left side, take this as  $\textcircled{a}$ , then draw a horizontal line from  $\textcircled{a}$ .
- (2) Locate the number 5 in the row across the top, take this as  $\textcircled{b}$ , then draw a perpendicular line down from  $\textcircled{b}$ .
- (3) Take the point where the two lines cross as  $\textcircled{c}$ . This point  $\textcircled{c}$  gives the value when converting from millimeters to inches. Therefore, 55 mm = 2.165 inches.

2. Convert 550 mm into inches.

- (1) The number 550 does not appear in the table, so divide by 10 (move the decimal point one place to the left) to convert it to 55 mm.
- (2) Carry out the same procedure as above to convert 55 mm to 2.165 inches.
- (3) The original value (550 mm) was divided by 10, so multiply 2.165 inches by 10 (move the decimal point one place to the right) to return to the original value.  
This gives 550 mm = 21.65 inches.

#### Millimeters to inches

$\textcircled{b}$

1mm = 0.03937 in

	0	1	2	3	4	5	6	7	8	9
0		0.039	0.079	0.118	0.157	0.197	0.236	0.276	0.315	0.354
10	0.394	0.433	0.472	0.512	0.551	0.591	0.630	0.669	0.709	0.748
20	0.787	0.827	0.866	0.906	0.945	0.984	1.024	1.063	1.102	1.142
30	1.181	1.220	1.260	1.299	1.339	1.378	1.417	1.457	1.496	1.536
40	1.575	1.614	1.654	1.693	1.732	1.772	1.811	1.850	1.890	1.929
$\textcircled{a}$ 50	1.969	2.008	2.047	2.087	2.126	$\textcircled{c}$ 2.165	2.205	2.244	2.283	2.323
60	2.362	2.402	2.441	2.480	2.520	2.559	2.598	2.638	2.677	2.717
70	2.756	2.795	2.835	2.874	2.913	2.953	2.992	3.032	3.071	3.110
80	3.150	3.189	3.228	3.268	3.307	3.346	3.386	3.425	3.465	3.504
90	3.543	3.583	3.622	3.661	3.701	3.740	3.780	3.819	3.858	3.898

**Millimeters to inches**

1mm = 0.03937in

	0	1	2	3	4	5	6	7	8	9
0		0.039	0.079	0.118	0.157	0.197	0.236	0.276	0.315	0.354
10	0.394	0.433	0.472	0.512	0.551	0.591	0.630	0.669	0.709	0.748
20	0.787	0.827	0.866	0.906	0.945	0.984	1.024	1.063	1.102	1.142
30	1.181	1.220	1.260	1.299	1.339	1.378	1.417	1.457	1.496	1.536
40	1.575	1.614	1.654	1.693	1.732	1.772	1.811	1.850	1.890	1.929
50	1.969	2.008	2.047	2.087	2.126	2.165	2.205	2.244	2.283	2.323
60	2.362	2.402	2.441	2.480	2.520	2.559	2.598	2.638	2.677	2.717
70	2.756	2.795	2.835	2.874	2.913	2.953	2.992	3.032	3.071	3.110
80	3.150	3.189	3.228	3.268	3.307	3.346	3.386	3.425	3.465	3.504
90	3.543	3.583	3.622	3.661	3.701	3.740	3.780	3.819	3.858	3.898

**Kilogram to Pound**

1kg = 2.2046lb

	0	1	2	3	4	5	6	7	8	9
0		2.20	4.41	6.61	8.82	11.02	13.23	15.43	17.64	19.84
10	22.05	24.25	26.46	28.66	30.86	33.07	35.27	37.48	39.68	41.89
20	44.09	46.30	48.50	50.71	51.91	55.12	57.32	59.5	61.73	63.93
30	66.14	68.34	70.55	72.75	74.96	77.16	79.37	81.57	83.78	85.98
40	88.18	90.39	92.59	94.80	97.00	99.21	101.41	103.62	105.82	108.03
50	110.23	112.44	114.64	116.85	119.05	121.25	123.46	125.66	127.87	130.07
60	132.28	134.48	136.69	138.89	141.10	143.30	145.51	147.71	149.91	152.12
70	154.32	156.53	158.73	160.94	163.14	165.35	167.55	169.76	171.96	174.17
80	176.37	178.57	180.78	182.98	185.19	187.39	189.60	191.80	194.01	196.21
90	198.42	200.62	202.83	205.03	207.24	209.44	211.64	213.85	216.05	218.26



**Liter to U.S. Gallon**

1 l = 0.2642 U.S.Gal

	0	1	2	3	4	5	6	7	8	9
0		0.264	0.528	0.793	1.057	1.321	1.585	1.849	2.113	2.378
10	2.642	2.906	3.170	3.434	3.698	3.963	4.227	4.491	4.755	5.019
20	5.283	5.548	5.812	6.076	6.340	6.604	6.869	7.133	7.397	7.661
30	7.925	8.189	8.454	8.718	8.982	9.246	9.510	9.774	10.039	10.303
40	10.567	10.831	11.095	11.359	11.624	11.888	12.152	12.416	12.680	12.944
50	13.209	13.473	13.737	14.001	14.265	14.529	14.795	15.058	15.322	15.586
60	15.850	16.115	16.379	16.643	16.907	17.171	17.435	17.700	17.964	18.228
70	18.492	18.756	19.020	19.285	19.549	19.813	20.077	20.341	20.605	20.870
80	21.134	21.398	21.662	21.926	22.190	22.455	22.719	22.983	23.247	23.511
90	23.775	24.040	24.304	24.568	24.832	25.096	25.361	25.625	25.889	26.153

**Liter to U.K. Gallon**

1 l = 0.21997 U.K.Gal

	0	1	2	3	4	5	6	7	8	9
0		0.220	0.440	0.660	0.880	1.100	1.320	1.540	1.760	1.980
10	2.200	2.420	2.640	2.860	3.080	3.300	3.520	3.740	3.950	4.179
20	4.399	4.619	4.839	5.059	5.279	5.499	5.719	5.939	6.159	6.379
30	6.599	6.819	7.039	7.259	7.479	7.699	7.919	8.139	8.359	8.579
40	8.799	9.019	9.239	9.459	9.679	9.899	10.119	10.339	10.559	10.778
50	10.998	11.281	11.438	11.658	11.878	12.098	12.318	12.528	12.758	12.978
60	13.198	13.418	13.638	13.858	14.078	14.298	14.518	14.738	14.958	15.178
70	15.398	15.618	15.838	16.058	16.278	16.498	16.718	16.938	17.158	17.378
80	17.598	17.818	18.037	18.257	18.477	18.697	18.917	19.137	19.357	19.577
90	19.797	20.017	20.237	20.457	20.677	20.897	21.117	21.337	21.557	21.777

kgf · m to lbf · ft

1 kgf · m = 7.233lbf · ft

	0	1	2	3	4	5	6	7	8	9
		7.2	14.5	21.7	28.9	36.2	43.4	50.6	57.9	65.1
10	72.3	79.6	86.8	94.0	101.3	108.5	115.7	123.0	130.2	137.4
20	144.7	151.9	159.1	166.4	173.6	180.8	188.1	195.3	202.5	209.8
30	217.0	224.2	231.5	238.7	245.9	253.2	260.4	267.6	274.9	282.1
40	289.3	296.6	303.8	311.0	318.3	325.5	332.7	340.0	347.2	354.4
50	361.7	368.9	376.1	383.4	390.6	397.8	405.1	412.3	419.5	426.8
60	434.0	441.2	448.5	455.7	462.9	470.2	477.4	484.6	491.8	499.1
70	506.3	513.5	520.8	528.0	535.2	542.5	549.7	556.9	564.2	571.4
80	578.6	585.9	593.1	600.3	607.6	614.8	622.0	629.3	636.5	643.7
90	651.0	658.2	665.4	672.7	679.9	687.1	694.4	701.6	708.8	716.1
100	723.3	730.5	737.8	745.0	752.2	759.5	766.7	773.9	781.2	788.4
110	795.6	802.9	810.1	817.3	824.6	831.8	839.0	846.3	853.5	860.7
120	868.0	875.2	882.4	889.7	896.9	904.1	911.4	918.6	925.8	933.1
130	940.3	947.5	954.8	962.0	969.2	976.5	983.7	990.9	998.2	10005.4
140	1012.6	1019.9	1027.1	1034.3	1041.5	1048.8	1056.0	1063.2	1070.5	1077.7
150	1084.9	1092.2	1099.4	1106.6	1113.9	1121.1	1128.3	1135.6	1142.8	1150.0
160	1157.3	1164.5	1171.7	1179.0	1186.2	1193.4	1200.7	1207.9	1215.1	1222.4
170	1129.6	1236.8	1244.1	1251.3	1258.5	1265.8	1273.0	1280.1	1287.5	1294.7
180	1301.9	1309.2	1316.4	1323.6	1330.9	1338.1	1345.3	1352.6	1359.8	1367.0
190	1374.3	1381.5	1388.7	1396.0	1403.2	1410.4	1417.7	1424.9	1432.1	1439.4

kgf/cm<sup>2</sup> to lbf/in<sup>2</sup>

1kgf / cm<sup>2</sup> = 14.2233lbf / in<sup>2</sup>

	0	1	2	3	4	5	6	7	8	9
		14.2	28.4	42.7	56.9	71.1	85.3	99.6	113.8	128.0
10	142.2	156.5	170.7	184.9	199.1	213.4	227.6	241.8	256.0	270.2
20	284.5	298.7	312.9	327.1	341.4	355.6	369.8	384.0	398.3	412.5
30	426.7	440.9	455.1	469.4	483.6	497.8	512.0	526.3	540.5	554.7
40	568.9	583.2	597.4	611.6	625.8	640.1	654.3	668.5	682.7	696.9
50	711.2	725.4	739.6	753.8	768.1	782.3	796.5	810.7	825.0	839.2
60	853.4	867.6	881.8	896.1	910.3	924.5	938.7	953.0	967.2	981.4
70	995.6	1010	1024	1038	1053	1067	1081	1095	1109	1124
80	1138	1152	1166	1181	1195	1209	1223	1237	1252	1266
90	1280	1294	1309	1323	1337	1351	1365	1380	1394	1408
100	1422	1437	1451	1465	1479	1493	1508	1522	1536	1550
110	1565	1579	1593	1607	1621	1636	1650	1664	1678	1693
120	1707	1721	1735	1749	1764	1778	1792	1806	1821	1835
130	1849	2863	1877	1892	1906	1920	1934	1949	1963	1977
140	1991	2005	2020	2034	2048	2062	2077	2091	2105	2119
150	2134	2148	2162	2176	2190	2205	2219	2233	2247	2262
160	2276	2290	2304	2318	2333	2347	2361	2375	2389	2404
170	2418	2432	2446	2460	2475	2489	2503	2518	2532	2546
180	2560	2574	2589	5603	2617	2631	2646	2660	2674	2688
200	2845	2859	2873	2887	2901	2916	2930	2944	2958	2973
210	2987	3001	3015	3030	3044	3058	3072	3086	3101	3115
220	3129	3143	3158	3172	3186	3200	3214	3229	3243	3257
230	3271	3286	3300	3314	3328	3343	3357	3371	3385	3399
240	3414	3428	3442	3456	3470	3485	3499	3513	3527	3542

## TEMPERATURE

Fahrenheit-Centigrade Conversion.

A simple way to convert a fahrenheit temperature reading into a centigrade temperature reading or vice versa is to enter the accompanying table in the center or boldface column of figures.

These figures refer to the temperature in either Fahrenheit or Centigrade degrees.

If it is desired to convert from Fahrenheit to Centigrade degrees, consider the center column as a table of Fahrenheit temperatures and read the corresponding Centigrade temperature in the column at the left.

If it is desired to convert from Centigrade to Fahrenheit degrees, consider the center column as a table of Centigrade values, and read the corresponding Fahrenheit temperature on the right.

°C	°F	°C	°F	°C	°F	°C	°F	°C	°F	°C	°F
-40.4	-40	-40.0	-11.7	11	51.8	7.8	46	114.8	27.2	81	117.8
-37.2	-35	-31.0	-11.1	12	53.6	8.3	47	116.6	27.8	82	179.6
-34.4	-30	-22.0	-10.6	13	55.4	8.9	48	118.4	28.3	83	181.4
-31.7	-25	-13.0	-10.0	14	57.2	9.4	49	120.2	28.9	84	183.2
-28.9	-20	-4.0	-9.4	15	59.0	10.0	50	122.0	29.4	85	185.0
-28.3	-19	-2.2	-8.9	16	60.8	10.6	51	123.8	30.0	86	186.8
-27.8	-18	-0.4	-8.3	17	62.6	11.1	52	125.6	30.6	87	188.6
-27.2	-17	1.4	-7.8	18	64.4	11.7	53	127.4	31.1	88	190.4
-26.7	-16	3.2	-6.7	20	68.0	12.8	55	131.0	32.2	90	194.0
-26.1	-15	5.0	-6.7	20	68.0	12.8	55	131.0	32.2	90	194.0
-25.6	-14	6.8	-6.1	21	69.8	13.3	56	132.8	32.8	91	195.8
-25.0	-13	8.6	-5.6	22	71.6	13.9	57	134.6	33.3	92	197.6
-24.4	-12	10.4	-5.0	23	73.4	14.4	58	136.4	33.9	93	199.4
-23.9	-11	12.2	-4.4	24	75.2	15.0	59	138.2	34.4	94	201.2
-23.3	-10	14.0	-3.9	25	77.0	15.6	60	140.0	35.0	95	203.0
-22.8	-9	15.8	-3.3	26	78.8	16.1	61	141.8	35.6	96	204.8
-22.2	-8	17.6	-2.8	27	80.6	16.7	62	143.6	36.1	97	206.6
-21.7	-7	19.4	-2.2	28	82.4	17.2	63	145.4	36.7	98	208.4
-21.1	-6	21.2	-1.7	29	84.2	17.8	64	147.2	37.2	99	210.2
-20.6	-5	23.0	-1.1	35	95.0	21.1	70	158.0	51.7	125	257.0
-20.0	-4	24.8	-0.6	31	87.8	18.9	66	150.8	40.6	105	221.0
-19.4	-3	26.6	0	32	89.6	19.4	67	152.6	43.3	110	230.0
-18.9	-2	28.4	0.6	33	91.4	20.0	68	154.4	46.1	115	239.0
-18.3	-1	30.2	1.1	34	93.2	20.6	69	156.2	48.9	120	248.0
-17.8	0	32.0	1.7	35	95.0	21.1	70	158.0	51.7	125	257.0
-17.2	1	33.8	2.2	36	96.8	21.7	71	159.8	54.4	130	266.0
-16.7	2	35.6	2.8	37	98.6	22.2	72	161.6	57.2	135	275.0
-16.1	3	37.4	3.3	38	100.4	22.8	73	163.4	60.0	140	284.0
-15.6	4	39.2	3.9	39	102.2	23.3	74	165.2	62.7	145	293.0
-15.0	5	41.0	4.4	40	104.0	23.9	75	167.0	65.6	150	302.0
-14.4	6	42.8	5.0	41	105.8	24.4	76	168.8	68.3	155	311.0
-13.9	7	44.6	5.6	42	107.6	25.0	77	170.6	71.1	160	320.0
-13.3	8	46.4	6.1	43	109.4	25.6	78	172.4	73.9	165	329.0
-12.8	9	48.2	6.7	44	111.2	26.1	79	174.2	76.7	170	338.0
-12.2	10	50.0	7.2	45	113.0	26.7	80	176.0	79.4	172	347.0

# SECTION 1 GENERAL

Group 1 Safety Hints .....	1-1
Group 2 Specifications .....	1-10
Group 3 Operational Checkout Record Sheet .....	1-27

# SECTION 1 GENERAL

## GROUP 1 SAFETY HINTS

### FOLLOW SAFE PROCEDURE

Unsafe work practices are dangerous. Understand service procedure before doing work; Do not attempt shortcuts.

### WEAR PROTECTIVE CLOTHING

Wear close fitting clothing and safety equipment appropriate to the job.

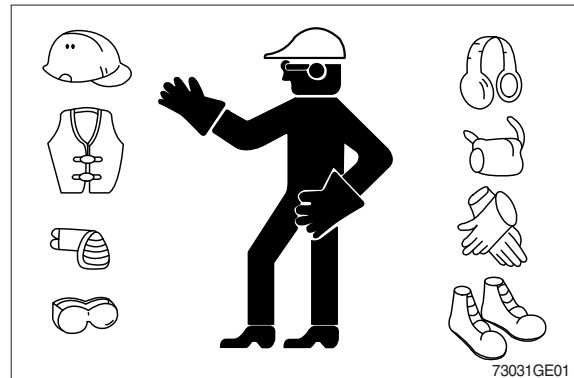

### WARN OTHERS OF SERVICE WORK

Unexpected machine movement can cause serious injury.

Before performing any work on the wheel loader, attach a 「Do Not Operate」 tag on the right side controller lever.

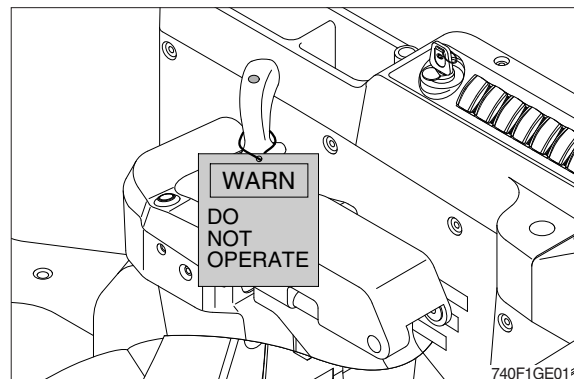

### USE HANDHOLDS AND STEPS

Falling is one of the major causes of personal injury.

When you get on and off the machine, always maintain a three point contact with the steps and handrails and face the machine. Do not use any controls as handholds.

Never jump on or off the machine. Never mount or dismount a moving machine.

Be careful of slippery conditions on platforms, steps, and handrails when leaving the machine.

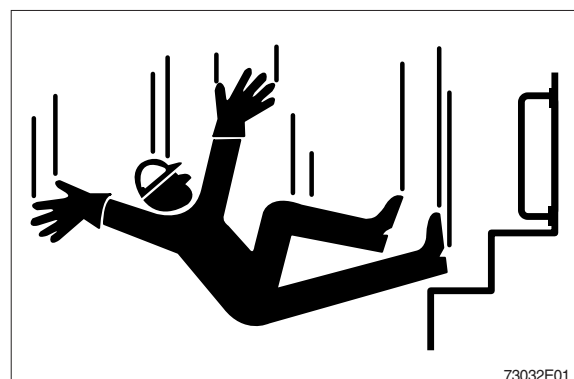

## PREPARE FOR EMERGENCIES

Be prepared if a fire starts.

Keep a first aid kit and fire extinguisher handy.

Keep emergency numbers for doctors, ambulance service, hospital, and fire department near your telephone.

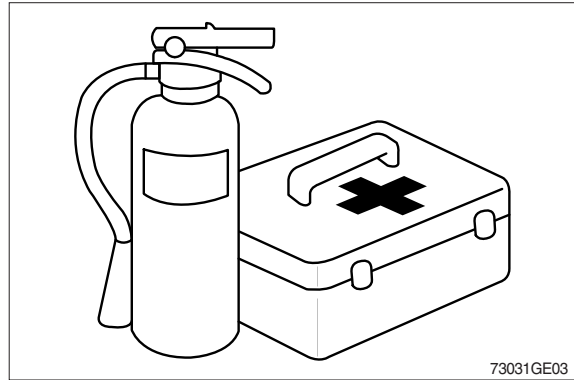

## WORK IN CLEAN AREA

Before starting a job :

- Clean work area and machine.
- Make sure you have all necessary tools to do your job.
- Have the right parts on hand.
- Read all instructions thoroughly; Do not attempt shortcuts.

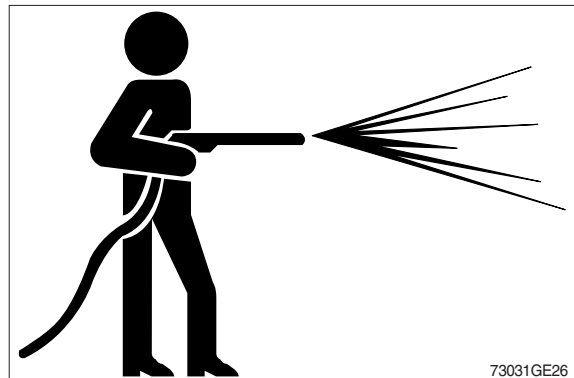

## PROTECT AGAINST FLYING DEBRIS

Guard against injury from flying pieces of metal or debris; Wear goggles or safety glasses.

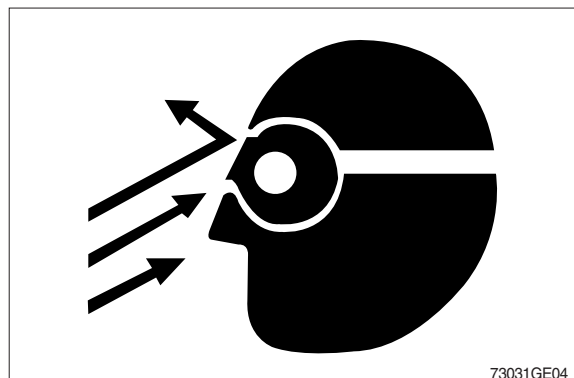

## PROTECT AGAINST NOISE

Prolonged exposure to loud noise can cause impairment or loss of hearing.

Wear a suitable hearing protective device such as earmuffs or earplugs to protect against objectionable or uncomfortable loud noises.

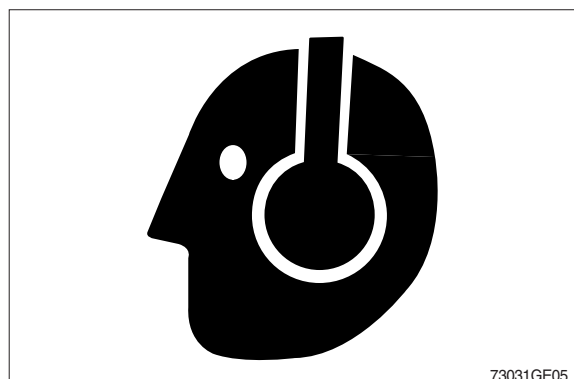

## PARK MACHINE SAFELY

Before working on the machine:

- Park machine on a level surface.
- Lower bucket to the ground.
- Turn key switch to OFF to stop engine.  
Remove key from switch.
- Move pilot cut off switch to locked position.
- Allow engine to cool.

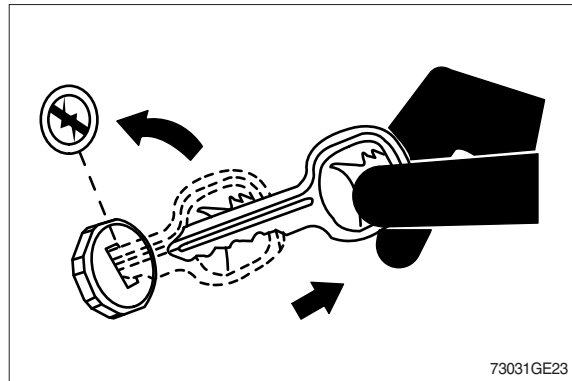

## SUPPORT MACHINE PROPERLY

Always lower the attachment or implement to the ground before you work on the machine. If you must work on a lifted machine or attachment, securely support the machine or attachment.

Do not support the machine on cinder blocks, hollow tiles, or props that may crumble under continuous load.

Do not work under a machine that is supported solely by a jack.

Follow recommended procedures in this manual.



## SERVICE COOLING SYSTEM SAFELY

Explosive release of fluids from pressurized cooling system can cause serious burns.

Shut off engine. Only remove filler cap when cool enough to touch with bare hands.

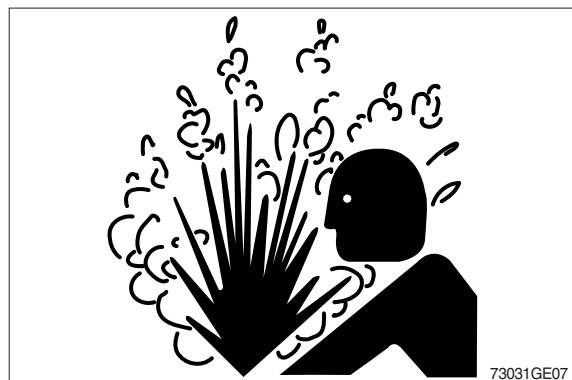

## HANDLE FLUIDS SAFELY-AVOID FIRES

Handle fuel with care; It is highly flammable. Do not refuel the machine while smoking or when near open flame or sparks. Always stop engine before refueling machine.

Fill fuel tank outdoors.

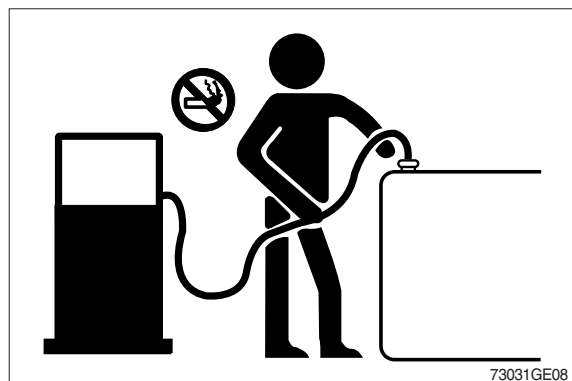



Store flammable fluids away from fire hazards. Do not incinerate or puncture pressurized containers.

Make sure machine is clean of trash, grease, and debris.

Do not store oily rags ; They can ignite and burn spontaneously.

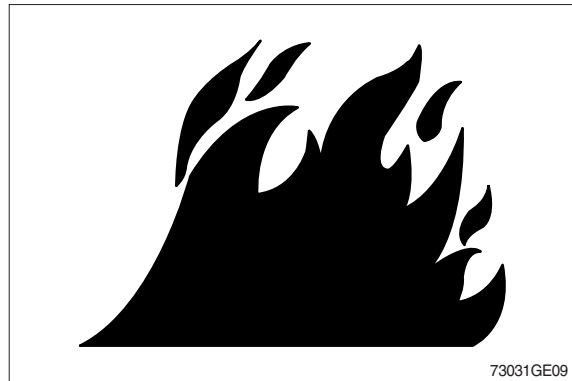

### **BEWARE OF EXHAUST FUMES**

Prevent asphyxiation. Engine exhaust fumes can cause sickness or death.

If you must operate in a building, be positive there is adequate ventilation. Either use an exhaust pipe extension to remove the exhaust fumes or open doors and windows to bring enough outside air into the area.

### **REMOVE PAINT BEFORE WELDING OR HEATING**

Avoid potentially toxic fumes and dust.

Hazardous fumes can be generated when paint is heated by welding, soldering, or using a torch.

Do all work outside or in a well ventilated area. Dispose of paint and solvent properly.

Remove paint before welding or heating:

- If you sand or grind paint, avoid breathing the dust. Wear an approved respirator.
- If you use solvent or paint stripper, remove stripper with soap and water before welding. Remove solvent or paint stripper containers and other flammable material from area. Allow fumes to disperse at least 15 minutes before welding or heating.

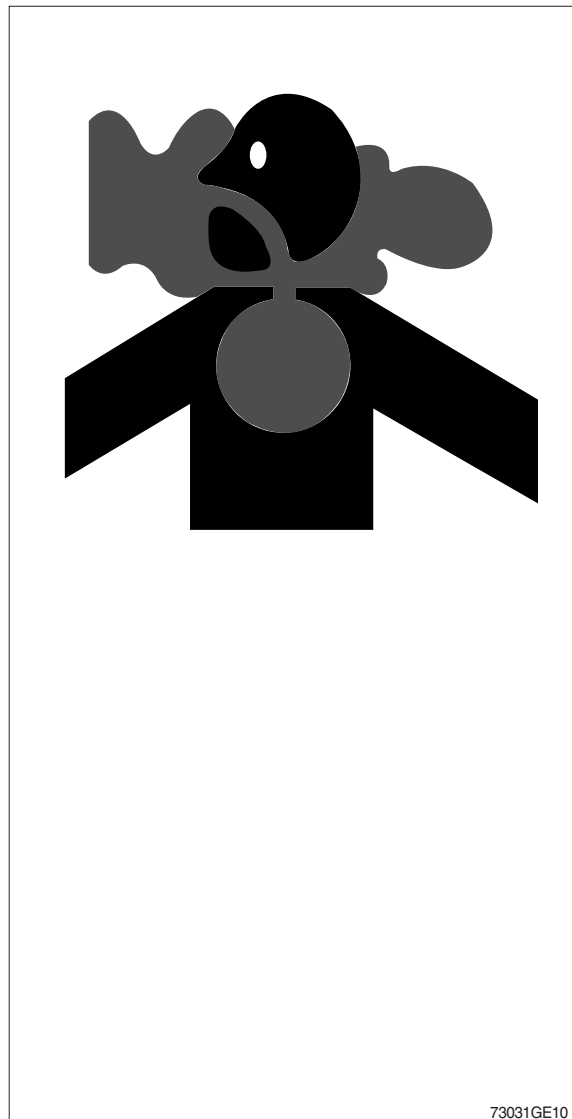

### ILLUMINATE WORK AREA SAFELY

Illuminate your work area adequately but safely. Use a portable safety light for working inside or under the machine. Make sure the bulb is enclosed by a wire cage. The hot filament of an accidentally broken bulb can ignite spilled fuel or oil.

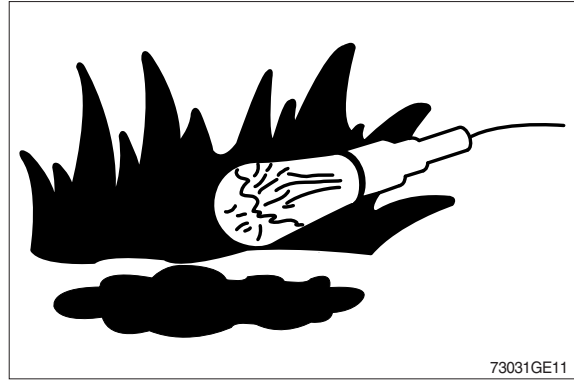

### SERVICE MACHINE SAFELY

Tie long hair behind your head. Do not wear a necktie, scarf, loose clothing or necklace when you work near machine tools or moving parts. If these items were to get caught, severe injury could result.

Remove rings and other jewelry to prevent electrical shorts and entanglement in moving parts.

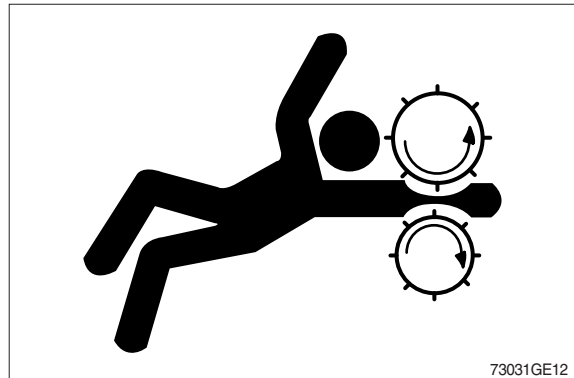

### STAY CLEAR OF MOVING PARTS

Entanglements in moving parts can cause serious injury.

To prevent accidents, use care when working around rotating parts.

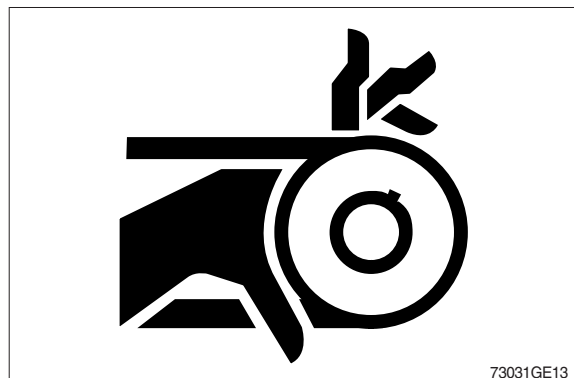

## AVOID HIGH PRESSURE FLUIDS

Escaping fluid under pressure can penetrate the skin causing serious injury.

Avoid the hazard by relieving pressure before disconnecting hydraulic or other lines. Tighten all connections before applying pressure.

Search for leaks with a piece of cardboard. Protect hands and body from high pressure fluids.

If an accident occurs, see a doctor immediately. Any fluid injected into the skin must be surgically removed within a few hours or gangrene may result.

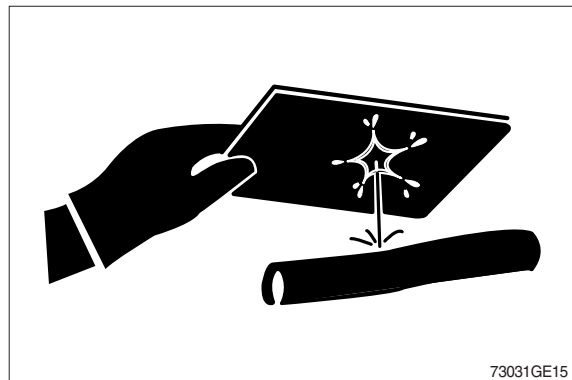

## AVOID HEATING NEAR PRESSURIZED FLUID LINES

Flammable spray can be generated by heating near pressurized fluid lines, resulting in severe burns to yourself and bystanders. Do not heat by welding, soldering, or using a torch near pressurized fluid lines or other flammable materials.

Pressurized lines can be accidentally cut when heat goes beyond the immediate flame area. Install fire resisting guards to protect hoses or other materials.



## PREVENT BATTERY EXPLOSIONS

Keep sparks, lighted matches, and flame away from the top of battery. Battery gas can explode.

Never check battery charge by placing a metal object across the posts. Use a volt-meter or hydrometer.

Do not charge a frozen battery; It may explode. Warm battery to 16°C (60°F).



## PREVENT ACID BURNS

Sulfuric acid in battery electrolyte is poisonous. It is strong enough to burn skin, eat holes in clothing, and cause blindness if splashed into eyes.

1. Avoid the hazard by:
  2. Filling batteries in a well-ventilated area.
  3. Wearing eye protection and rubber gloves.  
Avoiding breathing fumes when electrolyte is added.
  4. Avoiding spilling or dripping electrolyte.
  5. Use proper jump start procedure.
1. If you spill acid on yourself:
  2. Flush your skin with water.  
Apply baking soda or lime to help neutralize the acid.
  3. Flush your eyes with water for 10-15 minutes.  
Get medical attention immediately.
1. If acid is swallowed:
  2. Drink large amounts of water or milk.  
Then drink milk of magnesia, beaten eggs, or vegetable oil.
  3. Get medical attention immediately.

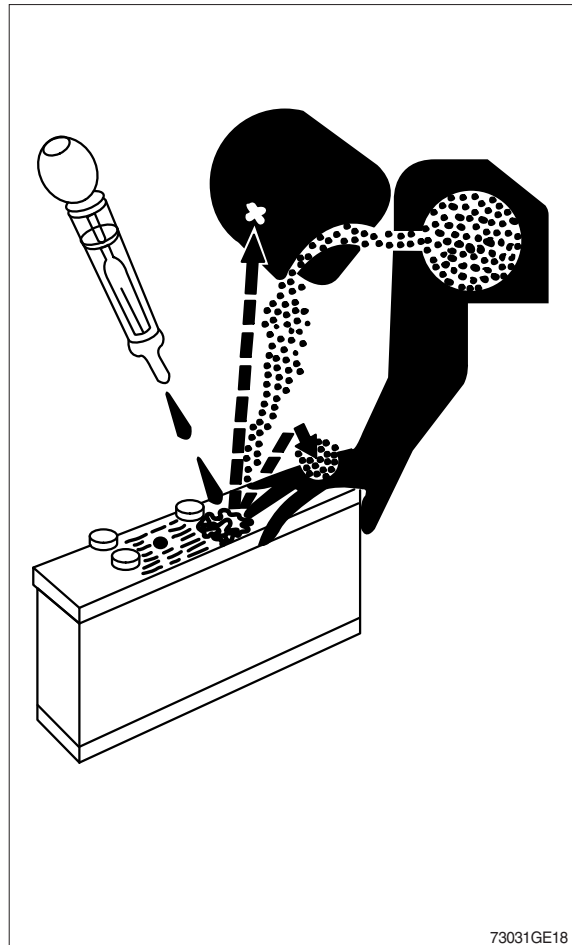

## USE TOOLS PROPERLY

Use tools appropriate to the work. Makeshift tools, parts, and procedures can create safety hazards.

Use power tools only to loosen threaded tools and fasteners.

For loosening and tightening hardware, use the correct size tools. Avoid bodily injury caused by slipping wrenches.

Use only recommended replacement parts.  
(See Parts catalogue.)

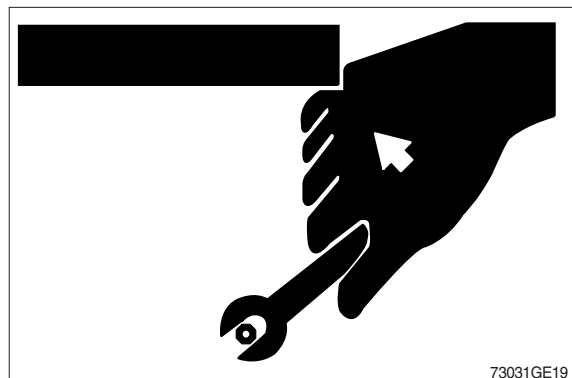

## SERVICE TIRES SAFELY

Explosive separation of a tire and rim parts can cause serious injury or death.

Do not attempt to mount a tire unless you have the proper equipment and experience to perform the job.

Always maintain the correct tire pressure. Do not inflate the tires above the recommended pressure. Never weld or heat a wheel and tire assembly. The heat can cause an increase in air pressure resulting in a tire explosion.

Welding can structurally weaken or deform the wheel.

When inflating tires, use a clip-on chuck and extension hose long enough to allow you to stand to one side and not in front of or over the tire assembly. Use a safety cage if available.

Check wheels for low pressure, cuts, bubbles, damaged rims or missing lug bolts and nuts.

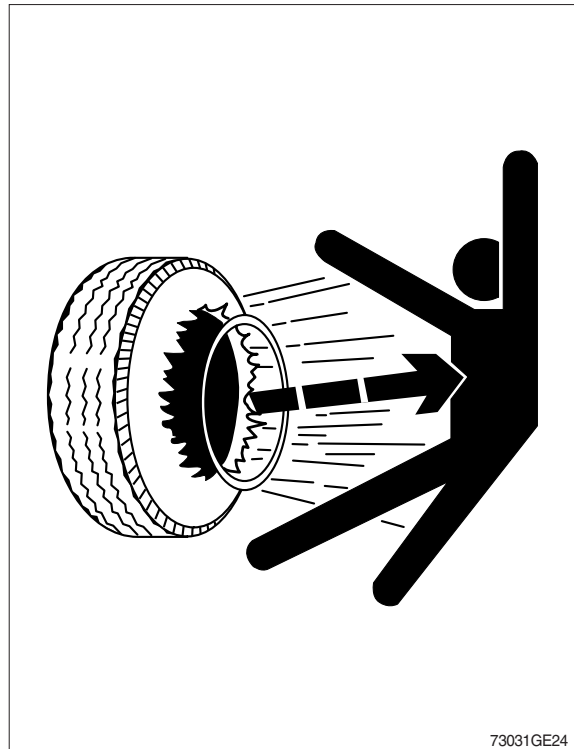

73031GE24

## USE PROPER LIFTING EQUIPMENT

Lifting heavy components incorrectly can cause severe injury or machine damage.

Follow recommended procedure for removal and installation of components in the manual.

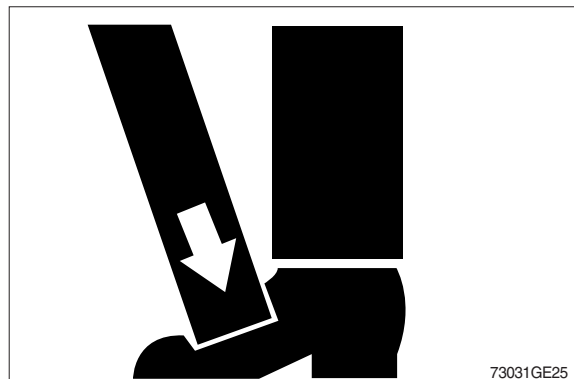

73031GE25

## DISPOSE OF FLUIDS PROPERLY

Improperly disposing of fluids can harm the environment and ecology. Before draining any fluids, find out the proper way to dispose of waste from your local environmental agency.

Use proper containers when draining fluids. Do not use food or beverage containers that may mislead someone into drinking from them.

DO NOT pour oil into the ground, down a drain, or into a stream, pond, or lake. Observe relevant environmental protection regulations when disposing of oil, fuel, coolant, brake fluid, filters, batteries, and other harmful waste.

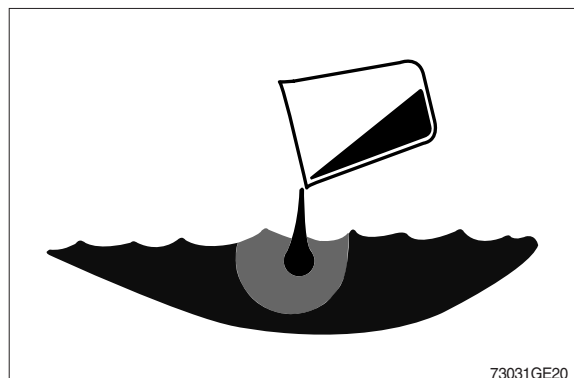

73031GE20

## REPLACE SAFETY SIGNS

Replace missing or damaged safety signs. See the machine operator's manual for correct safety sign placement.

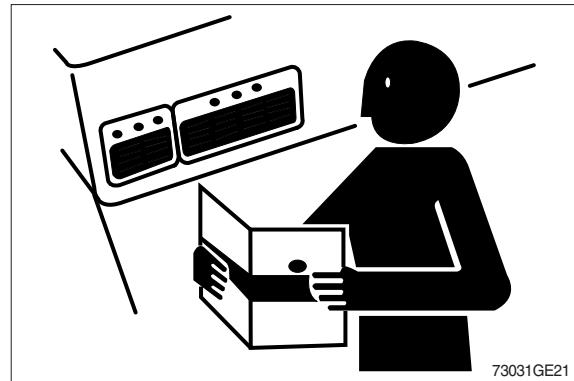

## LIVE WITH SAFETY

Before returning machine to customer, make sure machine is functioning properly, especially the safety systems. Install all guards and shields.

## KEEP ROPS INSTALLED PROPERLY

Make certain all parts are reinstalled correctly if the roll-over protective structure (ROPS) is loosened or removed for any reason. Tighten mounting bolts to proper torque.

The protection offered by ROPS will be impaired if ROPS is subjected to structural damage, is involved in an overturn incident, or is in any way altered by welding, bending, drilling, or cutting. A damaged ROPS should be replaced, not reused.

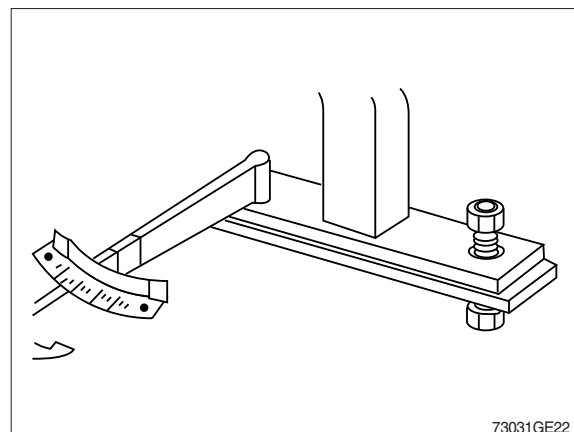

## GROUP 2 SPECIFICATION

### 1. MAJOR COMPONENT (HL940A, HL940A XT)

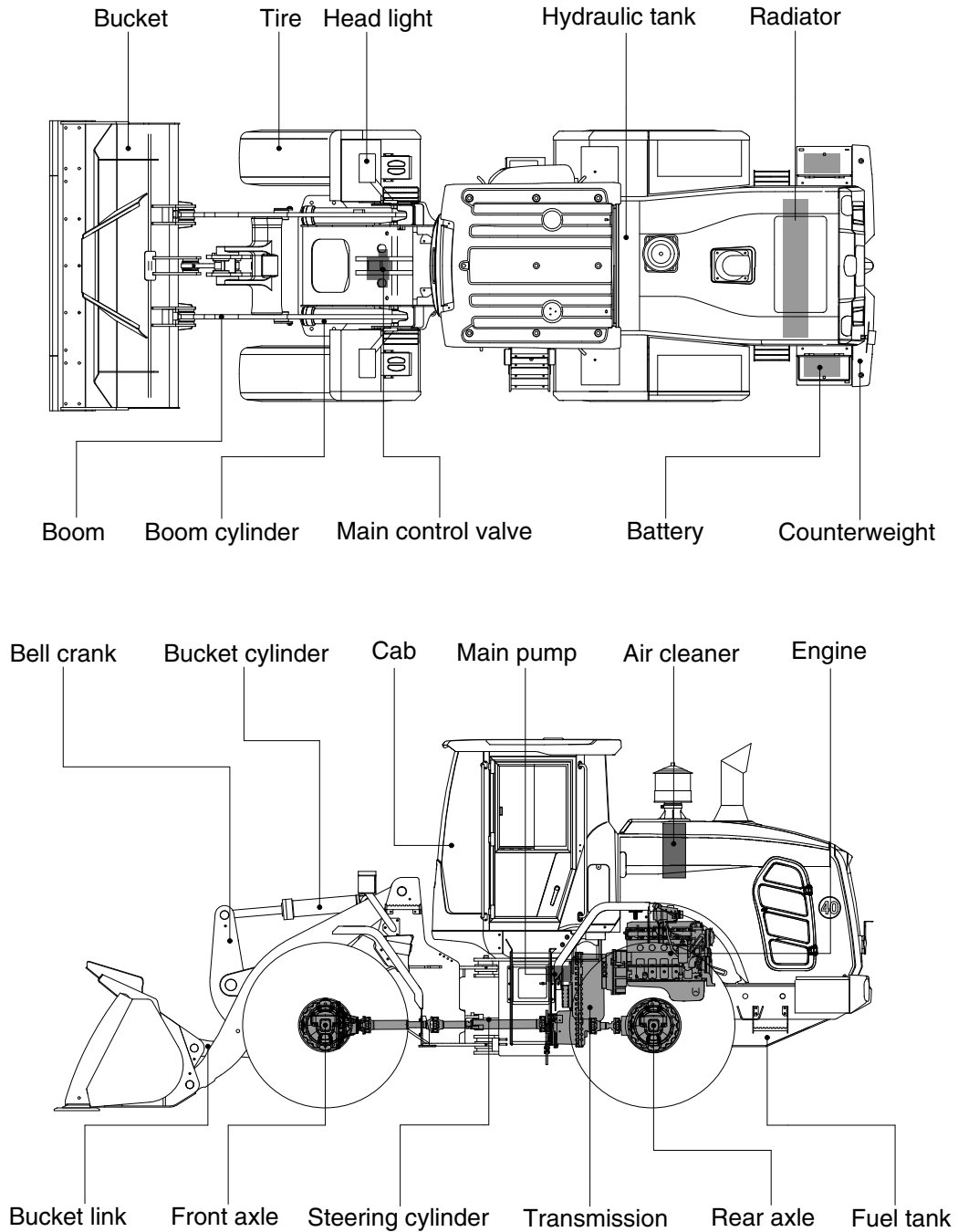

940A2SE01

# MAJOR COMPONENT (HL940A TM)

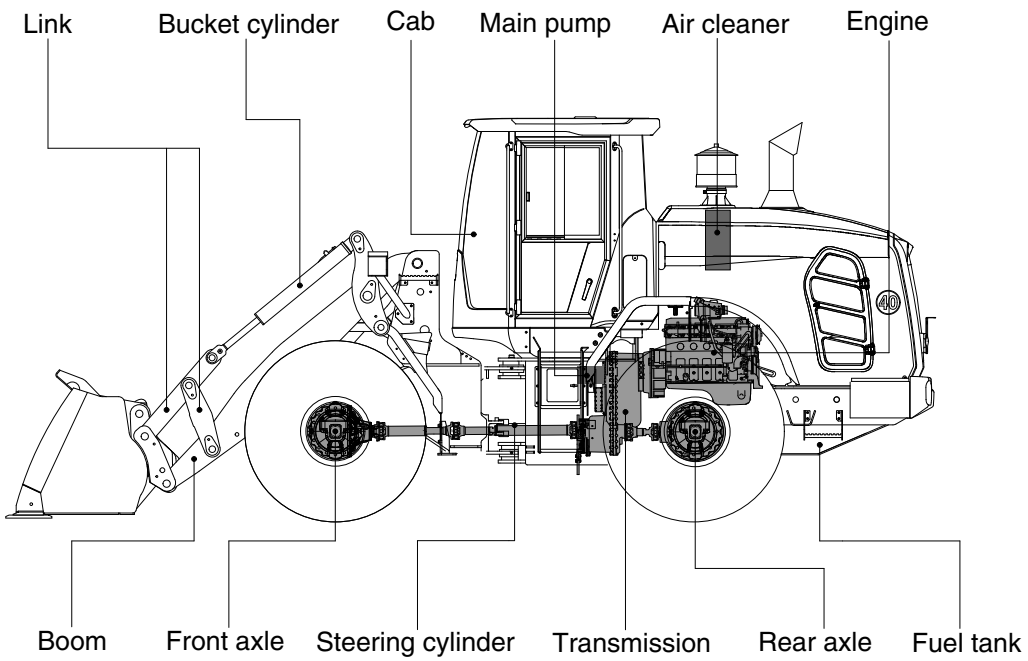
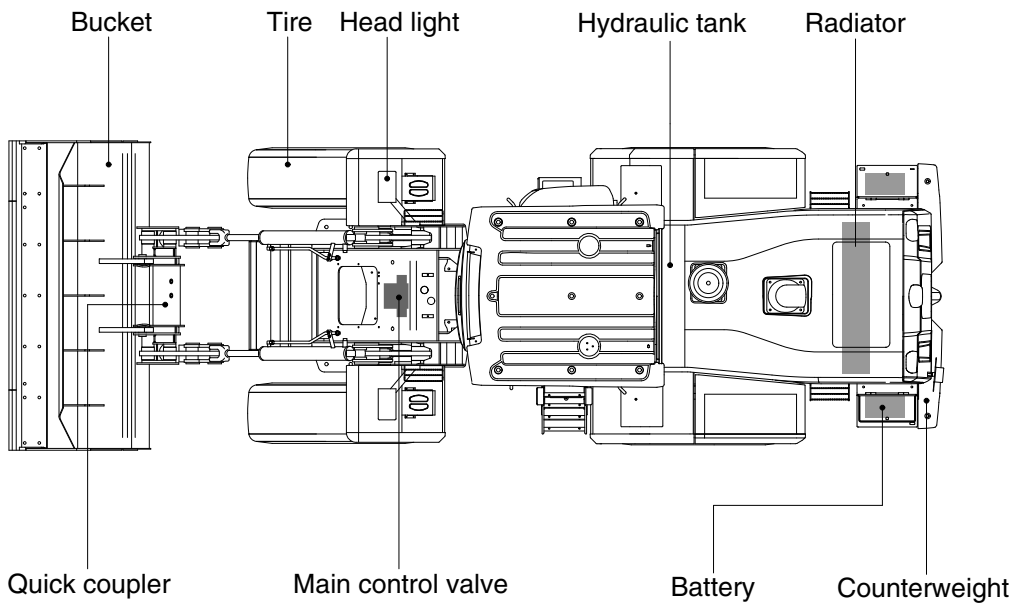

940ATM2SE01



## 2. SPECIFICATIONS

### 1) WITH BOLT-ON CUTTING EDGE TYPE BUCKET (HL940A)

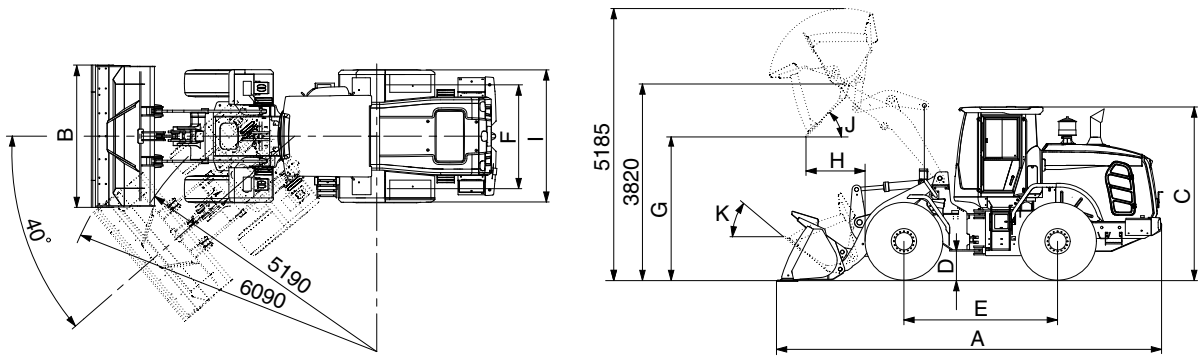

940A2SE03

Description		Unit	Specification	
Operating weight		kg (lb)	13400 (29540)	
Bucket capacity	Struck	m <sup>3</sup> (yd <sup>3</sup> )	2.0 (2.6)	
	Heaped		2.3 (3.0)	
Overall length	A	mm (ft-in)	7600 (24' 11")	
Overall width	B		2600 (8' 6")	
Overall height	C		3300 (10' 10")	
Ground clearance	D		417 (1' 5")	
Wheelbase	E		3000 (9' 10")	
Tread	F		1930 (6' 4")	
Dump clearance at 45°	G		2765 (9' 1")	
Dump reach (full lift)	H		1095 (3' 7")	
Width over tires	I		2450 (8' 0")	
Dump angle	J		degree (°)	48
Roll back angle (carry position)	K			47
Cycle time	Lift (with load)	sec	5.5	
	Dump (with load)		1.9	
	Lower (empty)		3.9	
Maximum travel speed		km/hr (mph)	40 (24.9)	
Braking distance		m (ft-in)	13.3 (43' 8")	
Minimum turning radius (center of outside tire)			5.19 (17' 0")	
Gradeability		degree (°)	30	
Breakout force		kg (lb)	11800 (26015)	
Travel speed	Forward	First gear	7.0 (4.3)	
		Second gear	12.8 (7.9)	
		Third gear	25.1 (15.6)	
		Fourth gear	40 (24.9)	
	Reverse	First gear	7.4 (4.6)	
		Second gear	13.5 (8.4)	
Third gear		26.5 (16.5)		

**WITH BOLT-ON CUTTING EDGE TYPE BUCKET (HL940A XT)**

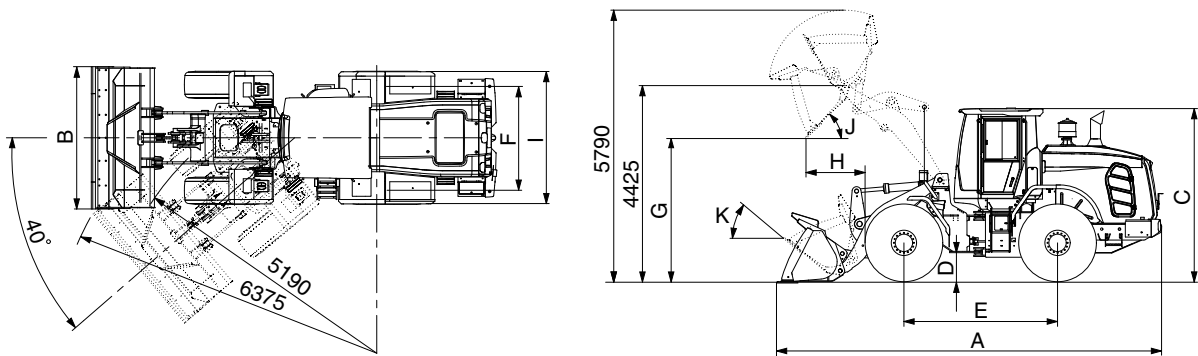

940A2SE03-2

Description		Unit	Specification	
Operating weight		kg (lb)	13860 (30560)	
Bucket capacity	Struck	m <sup>3</sup> (yd <sup>3</sup> )	2.0 (2.6)	
	Heaped		2.3 (3.0)	
Overall length	A	mm (ft-in)	8190 (26' 10")	
Overall width	B		2600 (8' 6")	
Overall height	C		3300 (10' 10")	
Ground clearance	D		417 (1' 4")	
Wheelbase	E		3000 (9' 10")	
Tread	F		1930 (6' 4")	
Dump clearance at 45°	G		3370 (11' 1")	
Dump reach (full lift)	H		1090 (3' 7")	
Width over tires	I		2450 (8' 0")	
Dump angle	J		degree (°)	47
Roll back angle (carry position)	K			50
Cycle time	Lift (with load)	sec	5.5	
	Dump (with load)		1.9	
	Lower (empty)		3.9	
Maximum travel speed		km/hr (mph)	40 (24.9)	
Braking distance		m (ft-in)	13.3 (43' 8")	
Minimum turning radius (center of outside tire)			5.19 (17' 0")	
Gradeability		degree (°)	30	
Breakout force		kg (lb)	11940 (26325)	
Travel speed	Forward	First gear	7.0 (4.3)	
		Second gear	12.8 (7.9)	
		Third gear	25.1 (15.6)	
		Fourth gear	40 (24.9)	
	Reverse	First gear	7.4 (4.6)	
		Second gear	13.5 (8.4)	
Third gear		26.4 (16.3)		

## WITH BOLT-ON CUTTING EDGE TYPE NARROW BUCKET (HL940A)

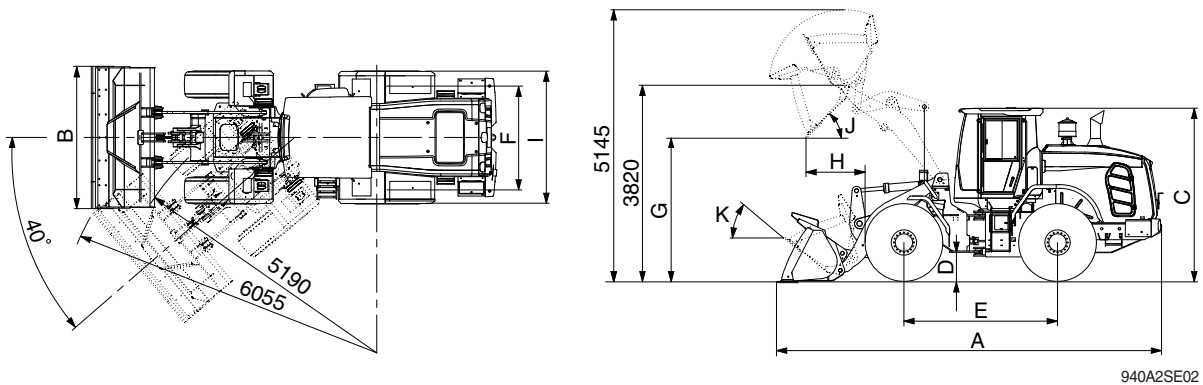

940A2SE02

Description		Unit	Specification	
Operating weight		kg (lb)	13360 (29450)	
Bucket capacity	Struck	m <sup>3</sup> (yd <sup>3</sup> )	1.8 (2.4)	
	Heaped		2.1 (2.7)	
Overall length	A	mm (ft-in)	7560 (24' 10")	
Overall width	B		2550 (8' 4")	
Overall height	C		3300 (10' 10")	
Ground clearance	D		432 (1' 5")	
Wheelbase	E		3000 (9' 10")	
Tread	F		1930 (6' 4")	
Dump clearance at 45°	G		2795 (9' 2")	
Dump reach (full lift)	H		1065 (3' 6")	
Width over tires	I		2450 (8' 0")	
Dump angle	J		degree (°)	48
Roll back angle (carry position)	K			47
Cycle time	Lift (with load)	sec	5.5	
	Dump (with load)		1.1	
	Lower (empty)		3.0	
Maximum travel speed		km/hr (mph)	40 (24.9)	
Braking distance		m (ft-in)	13.4 (44' 0")	
Minimum turning radius (center of outside tire)			5.19 (17' 0")	
Gradeability		degree (°)	30	
Breakout force		kg (lb)	12230 (26960)	
Travel speed	Forward	First gear	7.0 (4.3)	
		Second gear	12.8 (7.9)	
		Third gear	25.2 (15.6)	
		Fourth gear	40 (24.9)	
	Reverse	First gear	7.4 (4.6)	
		Second gear	13.5 (8.4)	
Third gear		26.5 (16.5)		

WITH BOLT-ON CUTTING EDGE TYPE NARROW BUCKET (HL940A XT)

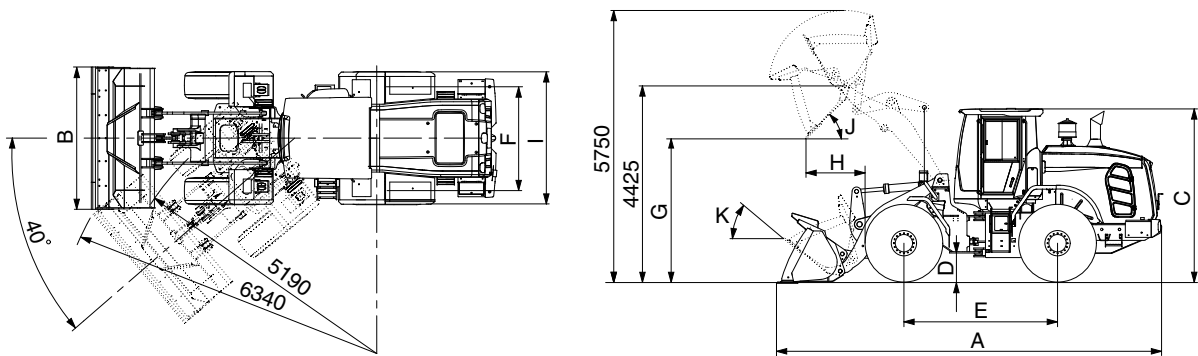

940A2SE02-1

Description		Unit	Specification	
Operating weight		kg (lb)	13820 (30470)	
Bucket capacity	Struck	m <sup>3</sup> (yd <sup>3</sup> )	1.8 (2.4)	
	Heaped		2.1 (2.7)	
Overall length	A	mm (ft-in)	8150 (26' 9")	
Overall width	B		2550 (8' 4")	
Overall height	C		3300 (10' 10")	
Ground clearance	D		432 (1' 5")	
Wheelbase	E		3000 (9' 10")	
Tread	F		1930 (6' 4")	
Dump clearance at 45°	G		3400 (11' 2")	
Dump reach (full lift)	H		1060 (3' 6")	
Width over tires	I		2450 (8' 0")	
Dump angle	J		degree (°)	47
Roll back angle (carry position)	K			50
Cycle time	Lift (with load)	sec	5.5	
	Dump (with load)		1.1	
	Lower (empty)		3.0	
Maximum travel speed		km/hr (mph)	40 (24.9)	
Braking distance		m (ft-in)	13.6 (44' 7")	
Minimum turning radius (center of outside tire)			5.19 (17' 0")	
Gradeability		degree (°)	30	
Breakout force		kg (lb)	12370 (27270)	
Travel speed	Forward	First gear	7.0 (4.3)	
		Second gear	12.8 (7.9)	
		Third gear	25.1 (15.6)	
		Fourth gear	40 (24.9)	
	Reverse	First gear	7.4 (4.6)	
		Second gear	13.5 (8.4)	
Third gear		26.3 (16.3)		

2) WITH BOLT-ON CUTTING EDGE TYPE BUCKET (HL940A TM)

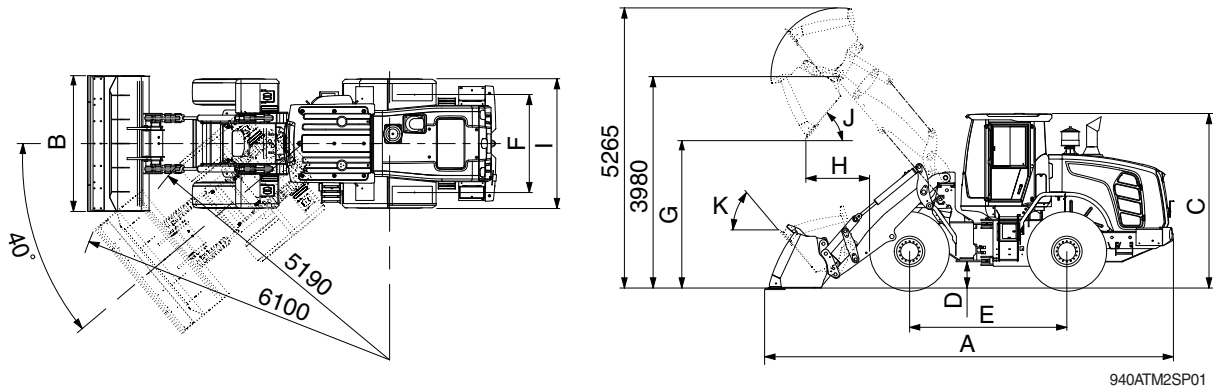

940ATM2SP01

Description		Unit	Specification	
Operating weight		kg (lb)	13800 (30420)	
Bucket capacity	Struck	m <sup>3</sup> (yd <sup>3</sup> )	2.0 (2.6)	
	Heaped		2.3 (3.0)	
Overall length	A	mm (ft-in)	7805 (25' 7")	
Overall width	B		2550 (8' 4")	
Overall height	C		3300 (10' 10")	
Ground clearance	D		417 (1' 4")	
Wheelbase	E		3000 (9' 10")	
Tread	F		1930 (6' 4")	
Dump clearance at 45°	G		2840 (9' 3")	
Dump reach (full lift)	H		1380 (4' 6")	
Width over tires	I		2450 (8' 0")	
Dump angle	J		degree (°)	50
Roll back angle (carry position)	K			54
Cycle time	Lift (with load)	sec	5.5	
	Dump (with load)		1.9	
	Lower (empty)		3.9	
Maximum travel speed		km/hr (mph)	40.0 (24.9)	
Braking distance		m (ft-in)	13.3 (43' 8")	
Minimum turning radius (center of outside tire)			5.19 (17' 0")	
Gradeability		degree (°)	30	
Brakeout force		kg (lb)	10830 (23880)	
Travel speed	Forward	First gear	7.0 (4.3)	
		Second gear	12.8 (7.9)	
		Third gear	25.1 (15.6)	
		Fourth gear	40.0 (24.9)	
	Reverse	First gear	7.4 (4.6)	
		Second gear	13.5 (8.4)	
Third gear		26.4 (16.4)		
Tipping load	Straight	kg (lb)	8880 (19580)	
	Full-turn		7640 (16840)	

### 3. WEIGHT

#### 1) HL940A, HL940A XT

Item		kg	lb
Front frame assembly		1007	2220
Rear frame assembly		1326	2923
Front fender (LH & RH)		63	139
Counterweight	HL940A	313	690
	HL940A XT	506	1115
Cab assembly		842	1856
Engine assembly		520	1150
Transmission assembly		430	948
Drive shaft (front)		19	41
Drive shaft (center)		19	41
Drive shaft (rear)		14	30
Front axle (include differential)		750	1653
Rear axle (include differential)		760	1675
Tire (20.5 R25, ★★.★L3)		238	525
Hydraulic tank assembly		142	313
Fuel tank assembly		291	641
Main pump assembly		35	77
Fan & brake pump assembly		17	37
Main control valve (2/3 spool)		44/50	97/110
Boom assembly	HL940A	717	1580
	HL940A XT	943	2078
Bell crank assembly		252	555
Quick coupler assembly		353	778
Bucket link		36	79
2.3 m <sup>3</sup> bucket, with bolt on cutting edge		1123	2475
Boom cylinder assembly		81	178
Bucket cylinder assembly (XT)		98/116	216/255
Steering cylinder assembly		17	37
Seat		70	154
Battery		30	66

## 2) HL940A TM

Item	kg	lb
Front frame assembly	1088	2398
Rear frame assembly	1333	2938
Front fender (LH & RH)	63	138
Counterweight (LH / RH)	250/250	551/551
Cab assembly	842	1856
Engine assembly	520	1146
Transmission assembly	430	947
Drive shaft (front)	15	33
Drive shaft (center)	22	48
Drive shaft (rear)	13	28
Front axle (include differential)	750	1653
Rear axle (include differential)	750	1653
Tire (20.5 R25, **, L3)	238	525
Hydraulic tank assembly	183	403
Fuel tank assembly	293	645
Main pump assembly	35	77
Fan & brake pump assembly	12	26
Main control valve (3 spool)	50	110
Boom assembly	692	1525
Quick coupler assembly	218	480
Bucket link	263	579
2.3 m <sup>3</sup> bucket, with bolt on cutting edge	1033	2277
Boom cylinder assembly	83	182
Bucket cylinder assembly	58	127
Steering cylinder assembly	17	37
Seat	70	154
Battery	30	66

#### 4. SPECIFICATION FOR MAJOR COMPONENTS

##### 1) ENGINE

Item	Specification
Model	Cummins B6.7
Type	4-cycle turbocharged and charge air-cooled diesel engine
Cooling method	Water cooling
Number of cylinders and arrangement	6 cylinders, in-line
Firing order	1-5-3-6-2-4
Combustion chamber type	Direct injection type
Cylinder bore × stroke	107 × 124 mm (4.2" × 4.9")
Piston displacement	6700 cc (408 cu in)
Compression ratio	17.3 : 1
Rated horse power (Gross)	156 hp at 2200 rpm
Maximum torque at 1300 rpm	76 kgf · m (550 lbf · ft)
Engine oil quantity	18 l (4.8 U.S. gal)
Wet weight	583 kg (1285 lb)
High idling speed	2230 ± 50 rpm
Low idling speed	800 ± 25 rpm
Rated fuel consumption	213 g/kW · hr
Starting motor	Denso PA90L (24V-7.8kW)
Alternator	Denso, 24V-95A
Battery	2 × 12V × 120Ah



## 2) MAIN PUMP

Item	Specification
Type	Variable piston pump
Capacity	74 cc/rev
Maximum operating pressure	280 kgf/cm <sup>2</sup> (3980 psi)
Maximum operating speed	2230 rpm
Rated output flow	149 l /min

## 3) FAN AND BRAKE PUMP

Item	Specification	
	Fan	Brake
Type	Variable piston pump	
Capacity	28 cc/rev	
Maximum operating pressure	250 bar	150 bar
Maximum operating speed	2230 rpm	
Rated output flow	56 l /min (14.8 U.S.gpm)	

## 4) MAIN CONTROL VALVE

Item	Specification
Type	3 spool
Operating method	Hydraulic pilot assist
Main relief valve set pressure	280 kgf/cm <sup>2</sup> (3980 psi)
Overload relief valve set pressure	340 kgf/cm <sup>2</sup> (4840 psi) /*150 kgf/cm <sup>2</sup> (2130 psi)

\* : Bucket dump (HL940A TM)

## 5) REMOTE CONTROL VALVE

Item	Specification	
Type	Joystick (or with aux lever)	
Control pressure	Minimum	3.7 kgf/cm <sup>2</sup> (52.6 psi)
	Maximum	30 kgf/cm <sup>2</sup> (427 psi)

## 6) CYLINDER

Item		Specification
Boom cylinder	Bore dia × Rod dia × Stroke	∅ 110 × ∅ 65 × 738 mm
Bucket cylinder (HL940A, HL940A XT)	Bore dia × Rod dia × Stroke	∅ 125 × ∅ 70 × 560 mm
Bucket cylinder (HL940A TM)	Bore dia × Rod dia × Stroke	∅ 95 × ∅ 50 × 745 mm
Steering cylinder	Bore dia × Rod dia × Stroke	∅ 65 × ∅ 40 × 429 mm

## 7) DYNAMIC POWER TRANSMISSION DEVICES

Item		Specification
Torque converter	Model	ZF 4WG160
	Type	Single-stage, single-phase
	Ratio	2.066 : 1
Transmission	Type	Full-automatic power shift
	Gear shift	Forward fourth gear, reverse third gear
	Control	Electrical single lever type, kick-down system
	Pump rated flow	70 l /min (18.5 U.S.gpm) at 2000 rpm
Axle	Drive devices	4-wheel drive
	Front	Front fixed location
	Rear	Oscillation ± 11° of center pin-loaded
Wheels	Tires	20.5 R25, ★★.L3
Brakes	Travel	Four-wheel, wet-disc type, full hydraulic
	Parking	Spring applied, hydraulic released brake on transmission
Steering	Type	Full hydraulic, articulated
	Steering angle	40° to both right and left angle, respectively

## 5. TIGHTENING TORQUE OF MAJOR COMPONENT

No.	Descriptions	Bolt size	Torque		
			kgf · m	lbf · ft	
1	Engine	Engine mounting bolt, nut (rubber, 2EA)	M20×2.5	57.9 ± 8.7	419 ± 63
2		Engine mounting bolt (bracket, 8EA)	M12×1.75	11.7 ± 1.8	84.6 ± 13
3		Engine mounting bolt (T/C plate-adapter, 4EA)	M10×1.5	6.9 ± 1.4	49.9 ± 10.1
4		Engine mounting stud bolt, nut (flywheel, 10EA)	M10×1.5	6.8 ± 1.0	49.2 ± 7.2
5		Engine mounting stud bolt (flywheel, 2EA)	M10×1.5	4.6 ± 0.9	33.3 ± 6.5
6		Fan motor mounting bolt	M12×1.75	12.8 ± 3.0	92.6 ± 21.7
7		Radiator mounting bolt	M16×2.0	29.7 ± 5.9	215 ± 42.7
8		Fuel tank mounting bolt	M16×2.0	29.7 ± 4.5	215 ± 32.5
9	Hydraulic system	Main pump housing mounting bolt	M16×2.0	29.7 ± 4.5	215 ± 32.5
10		Fan & brake pump housing mounting bolt	M10×1.5	6.9 ± 1.4	50 ± 10.1
11		Main control valve mounting bolt	M10×1.5	6.9 ± 1.4	50 ± 10.1
12		Steering unit mounting bolt	M10×1.5	6.9 ± 1.4	50 ± 10.1
13		Brake valve mounting bolt	M8×1.25	2.5 ± 0.5	18.1 ± 3.6
14		Cut-off valve mounting bolt	M8×1.25	2.5 ± 0.5	18.1 ± 3.6
15		Remote control lever mounting bolt	M6×1.0	1.1 ± 0.2	8.0 ± 1.4
16		Safety valve	M10×1.5	6.9 ± 1.4	50 ± 10.1
17		Hydraulic oil tank mounting bolt	M16×2.0	29.7 ± 4.5	215 ± 32.5
18	Power train system	Transmission mounting bolt, nut (rubber, 2EA)	M24×3.0	100 ± 15	723 ± 108
19		Transmission mounting bolt (bracket, 6EA)	M20×2.5	56.1 ± 8.4	406 ± 60.8
20		Front axle mounting bolt, nut	M27×2.0	135 ± 20.2	976 ± 146
21		Rear axle support mounting bolt, nut	M27×2.0	135 ± 15	976 ± 108
22		Tire mounting nut	M22×1.5	79 ± 11.9	571 ± 86.1
23		Drive shaft joint mounting bolt	3/8-24UNF	6.0 ± 0.8	43.4 ± 5.8
24	Others	Counterweight mounting bolt (4EA)	M30×3.5	199 ± 30	1439 ± 216
25		Operator's seat mounting bolt	M8×1.25	3.4 ± 0.8	24.6 ± 5.0
26		ROPS Cab mounting bolt (4EA)	M20×2.5	58 ± 8.7	419 ± 63
		ROPS Cab mounting nut (4EA)	M16×2.0	20.5 ± 4.7	148 ± 34

## 6. TORQUE CHART

Use following table for unspecified torque.

### 1) BOLT AND NUT

#### (1) Coarse thread

Bolt size	8.8T		10.9T		12.9T	
	kgf·m	lbf·ft	kgf·m	lbf·ft	kgf·m	lbf·ft
M 6 × 1.0	0.8 ~ 1.2	5.8 ~ 8.6	1.2 ~ 1.8	8.7 ~ 13.0	1.5 ~ 2.1	10.9 ~ 15.1
M 8 × 1.25	2.0 ~ 3.0	14.5 ~ 21.6	2.8 ~ 4.2	20.3 ~ 30.4	3.4 ~ 5.0	24.6 ~ 36.1
M10 × 1.5	4.0 ~ 6.0	29.0 ~ 43.3	5.6 ~ 8.4	40.5 ~ 60.8	6.8 ~ 10.0	49.2 ~ 72.3
M12 × 1.75	6.8 ~ 10.2	50.0 ~ 73.7	9.6 ~ 14.4	69.5 ~ 104	12.3 ~ 16.5	89.0 ~ 119
M14 × 2.0	10.9 ~ 16.3	78.9 ~ 117	16.3 ~ 21.9	118 ~ 158	19.5 ~ 26.3	141 ~ 190
M16 × 2.0	17.9 ~ 24.1	130 ~ 174	25.1 ~ 33.9	182 ~ 245	30.2 ~ 40.8	141 ~ 295
M18 × 2.5	24.8 ~ 33.4	180 ~ 241	34.8 ~ 47.0	252 ~ 340	41.8 ~ 56.4	302 ~ 407
M20 × 2.5	34.9 ~ 47.1	253 ~ 340	49.1 ~ 66.3	355 ~ 479	58.9 ~ 79.5	426 ~ 575
M22 × 2.5	46.8 ~ 63.2	339 ~ 457	65.8 ~ 88.8	476 ~ 642	78.9 ~ 106	570 ~ 766
M24 × 3.0	60.2 ~ 81.4	436 ~ 588	84.6 ~ 114	612 ~ 824	102 ~ 137	738 ~ 991
M30 × 3.5	120 ~ 161	868 ~ 1164	168 ~ 227	1216 ~ 1641	202 ~ 272	1461 ~ 1967

#### (2) Fine thread

Bolt size	8.8T		10.9T		12.9T	
	kgf · m	lbf · ft	kgf · m	lbf · ft	kgf · m	lbf · ft
M 8 × 1.0	2.1 ~ 3.1	15.2 ~ 22.4	3.0 ~ 4.4	21.7 ~ 31.8	3.6 ~ 5.4	26.1 ~ 39.0
M10 × 1.25	4.2 ~ 6.2	30.4 ~ 44.9	5.9 ~ 8.7	42.7 ~ 62.9	7.0 ~ 10.4	50.1 ~ 75.2
M12 × 1.25	7.3 ~ 10.9	52.8 ~ 78.8	10.3 ~ 15.3	74.5 ~ 110	13.1 ~ 17.7	94.8 ~ 128
M14 × 1.5	12.4 ~ 16.6	89.7 ~ 120	17.4 ~ 23.4	126 ~ 169	20.8 ~ 28.0	151 ~ 202
M16 × 1.5	18.7 ~ 25.3	136 ~ 182	26.3 ~ 35.5	191 ~ 256	31.6 ~ 42.6	229 ~ 308
M18 × 1.5	27.1 ~ 36.5	196 ~ 264	38.0 ~ 51.4	275 ~ 371	45.7 ~ 61.7	331 ~ 446
M20 × 1.5	37.7 ~ 50.9	273 ~ 368	53.1 ~ 71.7	384 ~ 518	63.6 ~ 86.0	460 ~ 622
M22 × 1.5	51.2 ~ 69.2	370 ~ 500	72.0 ~ 97.2	521 ~ 703	86.4 ~ 116	625 ~ 839
M24 × 2.0	64.1 ~ 86.5	464 ~ 625	90.1 ~ 121	652 ~ 875	108 ~ 146	782 ~ 1056
M30 × 2.0	129 ~ 174	933 ~ 1258	181 ~ 245	1310 ~ 1772	217 ~ 294	1570 ~ 2126

**2) PIPE AND HOSE (FLARE type)**

Thread size	Width across flat (mm)	kgf · m	lbf · ft
1/4"	19	4	28.9
3/8"	22	5	36.2
1/2"	27	9.5	68.7
3/4"	36	18	130
1"	41	21	152
1-1/4"	50	35	253

**3) PIPE AND HOSE (ORFS type)**

Thread size	Width across flat (mm)	kgf · m	lbf · ft
9/16-18	19	4	28.9
11/16-16	22	5	36.2
13/16-16	27	9.5	68.7
1-3/16-12	36	18	130
1-7/16-12	41	21	152
1-11/16-12	50	35	253

**4) FITTING**

Thread size	Width across flat (mm)	kgf · m	lbf · ft
1/4"	19	4	28.9
3/8"	22	5	36.2
1/2"	27	9.5	68.7
3/4"	36	18	130
1"	41	21	152
1-1/4"	50	35	253

## 7. RECOMMENDED LUBRICANTS

### 1) NEW MACHINE

New machine used and filled with following lubricants.

Description	Specification
Engine oil (API CK-4)	SAE 15W-40, * <sup>2</sup> SAE 5W-40
DEF/AdBlue®	ISO 22241 (32.5% high-purity urea and 67.5 deionized water)
Hydraulic oil	HD Hyundai Construction Equipment genuine long life (ISO VG 46, VG 68 only) Conventional (ISO VG15* <sup>2</sup> ) HD Hyundai Construction Equipment Bio Hydraulic Oil (HBHO, ISO VG 46)
Transmission oil	SAE 15W-40
Axle oil	* Refer to below list
Grease	Lithium base grease NLGI No. 2
Fuel	ASTM D975-No. 2, * <sup>1</sup> Ultra low sulfur diesel
Coolant	ASTM D6210 Mixture of 50% ethylene glycol base antifreeze and 50% water Mixture of 60% ethylene glycol base antifreeze and 40% water* <sup>2</sup>

**SAE** : Society of Automotive Engineers

**API** : American Petroleum Institute

**ISO** : International Organization for Standardization

**NLGI** : National Lubricating Grease Institute

**ASTM** : American Society of Testing and Material

**DEF** : Diesel Exhaust Fluid

DEF compatible with AdBlue®

\* Recommended oil list

- BP TERRAC SUPER TRANSMISSION 10W-30

- CASTROL AGRI TRANS PLUS 10W-30

- MOBILFLUID 426

- SHELL DONAX TD 10W-30

- TOTAL DYNATRANS MPV

\*<sup>1</sup> Ultra low sulfur diesel

- sulfur content ≤ 15 ppm

\*<sup>2</sup> Cold region

Russia, CIS, Mongolia

### 2) RECOMMENDED OILS

HD Hyundai Construction Equipment genuine lubricating oils have been developed to offer the best performance and service life for your equipment. These oils have been tested according to the specifications of HD Hyundai Construction Equipment and, therefore, will meet the highest safety and quality requirements.

We recommend that you use only HD Hyundai Construction Equipment genuine lubricating oils and grease officially approved by HD Hyundai Construction Equipment.

- ※ Using any lubricating oils other than HD Hyundai Construction Equipment genuine products may lead to a deterioration of performance and cause damage to major components.
- ※ Do not mix HD Hyundai Construction Equipment genuine oil with any other lubricating oil as it may result in damage to the systems of major components.
- ※ Do not use any engine oil other than that specified above, as it may clog the diesel particulate filter(DPF).
- ※ For HD Hyundai Construction Equipment genuine lubricating oils and grease for use in regions with extremely low temperatures, please contact HD Hyundai Construction Equipment dealers.

Service point	Kind of fluid	Capacity ℓ (U.S. gal)	Ambient temperature °C(°F)							
			-50 (-58)	-30 (-22)	-20 (-4)	-10 (14)	0 (32)	10 (50)	20 (68)	30 (86)
Engine oil pan	Engine oil	18 (4.8)	SAE 15W-40							
			* <sup>2</sup> SAE 5W-40							
			SAE 0W-40							
DEF/ AdBlue® tank	Mixture of urea and deionized water	30 (7.9)	ISO 22241, High-purity urea + deionized water (32.5 : 67.5)							
Transmission	Engine oil	34.7 (9.2)	SAE 10W-30							
			SAE 15W-40							
Axle	UTTO	Front : 23 (6.1) Rear : 23 (6.1)	*Refer to below list							
Hydraulic tank	Hydraulic oil	Tank: 90 (23.7) System: 130 (34.3)	* <sup>2</sup> ISO VG 15							
			ISO VG 46, HBHO VG 46* <sup>4</sup>							
			ISO VG 68							
Fuel tank	Diesel fuel* <sup>1</sup>	220 (58.1)	* <sup>2</sup> ASTM D975 NO.1							
			ASTM D975 NO.2							
Fitting (grease nipple)	Grease	As required	* <sup>2</sup> NLGI NO.1							
			NLGI NO.2							
Radiator (reservoir tank)	Mixture of antifreeze and soft water* <sup>3</sup>	37 (9.8)	Ethylene glycol base permanent type (50 : 50)							
			* <sup>2</sup> Ethylene glycol base permanent type (60 : 40)							

**SAE** : Society of Automotive Engineers

**API** : American Petroleum Institute

**ISO** : International Organization for Standardization

**NLGI** : National Lubricating Grease Institute

**ASTM** : American Society of Testing and Material

**UTTO** : Universal Tractor Transmission Oil

**DEF** : Diesel Exhaust Fluid  
DEF compatible with AdBlue®

\*<sup>1</sup> Ultra low sulfur diesel  
- sulfur content ≤ 15 ppm

\* Recommended oil list

- BP TERRAC SUPER TRANSMISSION 10W-30

- CASTROL AGRI TRANS PLUS 10W-30

- MOBILFLUID 426

- SHELL DONAX TD 10W-30

- TOTAL DYNATRANS MPV

\*<sup>2</sup> Cold region : Russia, CIS, Mongolia

\*<sup>3</sup> Soft water : City water or distilled water

\*<sup>4</sup> HD Hyundai Construction Equipment Bio Hydraulic Oil

## GROUP 3 OPERATIONAL CHECKOUT RECORD SHEET

- Owner :
- Date :
- Hours :
- Serial No. :
- Technician :

※ **Use this sheet to record operational checkout results.**  
**Perform the operational check before installing any test equipment.**

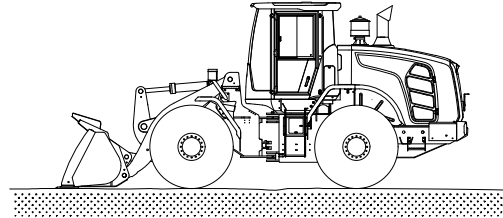

740F1GE02

Item	OK	NOT OK	Comments
------	----	-----------	----------

### 1. Monitor indicator and gauge checks (engine OFF)

- Hourmeter and gauge check   \_\_\_\_\_
- Battery check   \_\_\_\_\_
- Monitor indicator circuit check   \_\_\_\_\_
- Cluster turn signals and warning indicator check   \_\_\_\_\_

### 2. Transmission, axle and engine, neutral start switch and reverse warning alarm switch checks

- Transmission control lever and neutral   \_\_\_\_\_
- Neutral start and reverse warning   \_\_\_\_\_
- Alarm circuit checks   \_\_\_\_\_

### 3. Monitor indicator and gauge checks (engine running)

- Monitor display and alternator output checks   \_\_\_\_\_
- Monitor bypass circuit and seat belt indicator check   \_\_\_\_\_
- Monitor primary and secondary level check   \_\_\_\_\_
- Transmission oil warm up procedure   \_\_\_\_\_
- Transmission temperature gauge check   \_\_\_\_\_



This as a preview PDF file from [best-manuals.com](http://best-manuals.com)



Download full PDF manual at [best-manuals.com](http://best-manuals.com)