

SERVICE MANUAL

MC22 / MC28 / MC35
Commercial Mower

Print No. 604.55.081.00



SERVICE MANUAL

MC22 / MC28 / MC35

Commercial Mower

Print No. 604.55.081.00



CONTENTS

- SECTION 00 - GENERAL INFORMATION**
- SECTION 10 - ENGINE AND FUEL SYSTEMS**
- SECTION 25 - FOUR WHEEL DRIVE REAR AXLE**
- SECTION 27 - DIFFERENTIAL, AXLES**
- SECTION 31- PTO**
- SECTION 33 – BRAKES**
- SECTION 35 - HYDRAULIC SYSTEM**
- SECTION 41 – STEERING**
- SECTION 44 - TWO-WHEEL DRIVE REAR AXLE**
- SECTION 55 – ELECTRICAL**
- SECTION 90 - PLATFORM**

SECTION 00 - GENERAL INFORMATION

Chapter 1 - General Information

CONTENTS

Section	Description	Page
	Introduction	00-2
	Precautionary Statements	00-3
	Technical Information	00-4
	Safety Precautions	00-5
	Decals	00-12
	Safety Decals	00-13
	Instruction Decals	00-14
	International Symbols	00-17
	Specifications	00-18
	Minimum Hardware Tightening Torques	00-25
	Special Tools	00-27
	Torque Applications	00-28
00 400	Lubricants	00-29
	Touch-Up Paint	00-30
00 100	Pre-Season and Predelivery Service	00-31

INTRODUCTION

This repair manual provides the technical information needed to properly service the New Holland MC22, MC28, and MC35 tractors. Use this manual in conjunction with the operator's manual for complete operation, adjustment, and maintenance information.

On New Holland equipment, left and right are determined by standing behind the unit, looking in the direction of travel.

PRECAUTIONARY STATEMENTS

PERSONAL SAFETY

Throughout this manual and on machine decals, you will find precautionary statements (“**DANGER**”, “**WARNING**”, and “**CAUTION**”) followed by specific instructions. These precautions are intended for the personal safety of you and those working with you. Please take the time to read them.

 **DANGER** 

This word “**DANGER**” indicates an immediate hazardous situation that, if not avoided, will result in death or serious injury. The color associated with Danger is **RED**.

 **WARNING** 

This word “**WARNING**” indicates a potentially hazardous situation that, if not avoided, could result in death or serious injury. The color associated with Warning is **ORANGE**.

 **CAUTION** 

This word “**CAUTION**” indicates a potentially hazardous situation that, if not avoided, may result in minor or moderate injury. It may also be used to alert against unsafe practices. The color associated with Caution is **YELLOW**.

FAILURE TO FOLLOW THE “DANGER”, “WARNING”, AND “CAUTION” INSTRUCTIONS MAY RESULT IN SERIOUS BODILY INJURY OR DEATH.

MACHINE SAFETY

The precautionary statement (“**IMPORTANT**”) is followed by specific instructions. This statement is intended for machine safety.

IMPORTANT: *The word “IMPORTANT” is used to inform the reader of something he needs to know to prevent minor machine damage if a certain procedure is not followed.*

INFORMATION

NOTE: *Instructions used to identify and present supplementary information.*

TECHNICAL INFORMATION

HARDWARE

GENERAL

The MC22, MC28, and MC35 tractors have been built using metric hardware.

NOTE: *Be sure to use the hardware specified when using tapped holes, as trying to install a metric bolt in an inch thread, or an inch bolt in a metric thread, will damage the thread.*

Certain hardware must be tightened to specific torque specifications. If specific torque specifications are not noted, tighten the hardware to the standard torque chart specification listed in this manual.

PLATING

Hardware used on New Holland balers is plated with zinc chromate (gold color). Gold colored hardware has different torquing requirements from unplated or zinc plated (silver color) hardware because of the difference in the coefficient of friction of the plating material. The torque charts in this manual list the correct specifications for gold, silver, and unplated bolts.

NUT TIGHTENING

Whenever possible, the nut should be tightened, not the head of the bolt. When tightening using the bolt head, the clamp load can be lost because some of the torque applied twists the bolt instead of tensioning (stretching) it. The tension on the bolt is what holds the joint together.

Approximately 90% of the torque applied during assembly goes to overcoming friction between the parts. The other 10% is used to tension (stretch) the bolt. After assembly, the frictional forces disappear, which is the basis for the saying "If it does not fail during assembly, it will not fail in service." The bolt may later fail due to other factors, but not from being overtightened.

LOCKNUTS

Most locknuts are coated with a special lubricant that is dry to the touch. Any time a locknut is used, a lower than normal torque is required. Refer to the torque charts in this manual for specific values.

JAM NUTS

When using a jam nut to lock a regular nut, the jam nut should be installed first and tightened to one half the recommended torque, then held in place while installing a regular nut to the recommended torque.

THREAD LUBRICATION

The addition of antiseize compound, Molykote, oil, graphite, or any other lubricant to a bolt decreases the friction between it and a nut. This makes it necessary to reduce the recommended torque to prevent overtensioning of the bolt. When using the torque charts in this manual, decrease the value by 20% whenever a lubricant is used.

SAFETY PRECAUTIONS

**The following precautions are suggested to help prevent accidents.
SEE SPECIFIC INSTRUCTIONS IN TEXT FOR DETAIL.**

A careful operator is the best operator. Most accidents can be avoided by observing certain precautions. Read and take the following precautions, before operating the commercial mower, to prevent accidents. Equipment should be operated only by those who are responsible and instructed to do so.

This cutting machine is capable of amputating hands and feet and throwing objects. Failure to observe the following safety instructions could result in serious injury or death.

COMMERCIAL MOWER

1. All persons who will operate the unit should read the Operators Manual carefully before using the equipment. Lack of operating knowledge can lead to accidents.
2. Permit only properly trained and qualified persons to operate the unit.
3. Use the step plates when getting on and off the unit to prevent falls. Keep steps and platform cleared of mud and debris.
4. Use an approved Rollover Protective Structure (ROPS) and seat belt for safe operation. Overturning a unit without a ROPS and seat belt can result in death or injury. If the standard ROPS or seat belt has been removed, see your New Holland Dealer for a replacement.
5. Always use the seat belt with ROPS. If the ROPS has been removed, do not use the seat belt.
6. Do not permit anyone but the operator to ride on the unit. There is no safe place for extra riders.
7. Replace missing, illegible, or damaged safety decals.
8. Keep safety decals clean of dirt and grime.

Servicing the Commercial Mower

1. The cooling system operates under pressure which is controlled by the radiator cap. It is dangerous to remove the cap while the system is hot. Always turn the cap slowly to the first stop and allow the pressure to escape before removing the cap entirely.
2. Do not smoke while refueling the unit. Keep any type of open flame away. Wait for the engine to cool before refueling.
3. Keep the Commercial Mower in good operating condition for your safety. An improperly maintained unit can be hazardous.
4. Keep open flame away from battery or cold weather starting aids to prevent fires or explosions. Use jumper cables, according to instructions, to prevent sparks which could cause explosion.
5. Before servicing, park the unit on a firm, level surface and apply the parking brake. Remove the key to prevent accidental start-up.
6. Escaping hydraulic/diesel fluid under pressure can penetrate the skin, causing serious injury.
 - Do not use your hand to check for leaks. Use a piece of cardboard or paper to search for leaks.
 - Stop the engine and relieve pressure before connecting or disconnecting lines.
 - Tighten all connections before starting the engine or pressurizing lines.
 - If fluid is injected into skin, obtain medical attention immediately or gangrene may result.
7. Do not modify, alter, or permit anyone else to modify or alter this unit or any of its components, or any unit function without first consulting your New Holland Dealer.

SAFETY PRECAUTIONS

8. The fuel oil in the injection system is under high pressure and can penetrate the skin. Unqualified persons should not remove or attempt to adjust a pump, injector nozzle, or any other part of the fuel injection system. Failure to follow these instructions can result in serious injury.
9. Some components on your Commercial Mower, such as gaskets, may contain asbestos. Breathing asbestos dust is dangerous to your health. You are therefore advised to have any maintenance or repair operations on such components carried out by an authorized New Holland Dealer. If, however, service operations are to be undertaken on parts that contain asbestos, the essential precautions listed below must be observed:
 - Work out of doors or in a well ventilated area.
 - Dust found on the unit or produced during work on the unit should be removed by extraction, not by blowing.
 - Dust waste should be dampened, placed in a sealed container and marked to ensure safe disposal.
 - If any cutting, drilling, etc., is attempted on materials containing asbestos, the item should be dampened and only hand tools or low speed power tools used.
10. Continuous long term contact with used engine oil has caused skin cancer in animal tests. Avoid prolonged skin contact with used engine oil. Wash skin promptly with soap and water.
11. Do not work under a raised attachment unless it is securely supported by a suitable hoist or floor jack and multiple jack stands.
12. The ROPS and seat belt must be properly maintained and must not be modified, drilled, or altered in any way. If the ROPS is damaged, it must be replaced and should not be straightened or welded.

DRIVING THE COMMERCIAL MOWER

1. Watch where you are going, especially at row ends, on roads, around trees and low hanging obstacles.
2. To avoid upsets, drive the Commercial mower with care and at speeds compatible with safety, especially when operating over rough ground, when crossing ditches or slopes, and when turning corners.
3. Keep the unit in the same gear when going downhill as used when going uphill. Do not coast or free wheel down hills.
4. When the unit is stuck or tires are frozen to the ground, go up forward to prevent upset.
5. Always check overhead clearance, especially when transporting the Commercial Mower.
6. Avoid quick stops, especially when an attachment is raised or not installed. Quick stops can cause upsets.
7. Do not attach chains or ropes to the ROPS for pulling purposes.

OPERATING THE POWER TAKE OFF (PTO)

Before installing or using PTO-driven equipment, read the manufacturer's manual and review the safety labels attached to the equipment.

1. When operating PTO-driven equipment, shut off the engine and wait until the PTO stops before getting off the unit and disconnecting the equipment.
2. Do not wear loose clothing when operating the power take-off or when near rotating equipment.
3. When operating stationary PTO-driven equipment, always place the gear shift lever in neutral, apply the parking brake and block in front wheels front and back.
4. To avoid injury, do not clear, adjust, unclog or service PTO-driven equipment when the tractor engine is running.

SAFETY PRECAUTIONS

OPERATING THE MOWER DECK

1. Release the Commercial Mower HST foot pedal, apply the parking brake, place PTO lever in the "OFF" position, the lift control lever in neutral position and the transmission in neutral before starting the engine.
2. Do not start the engine or operate controls while standing beside the unit. Always sit in the seat when starting the engine or operating controls.
3. Do not bypass the neutral safety start switch. Consult your New Holland Dealer if your neutral safety start controls malfunction.
4. Use jumper cables only in the recommended manner. Improper use can result in the unit running away.
5. Avoid accidental contact with the gear shift lever while the engine is running.
6. Do not get off the Commercial Mower while it is in motion.
7. Disengage the PTO, shut off the engine and apply the parking brake before getting off the unit.
8. Do not park the Commercial Mower on a steep incline.
9. Do not operate the engine in an enclosed building without adequate ventilation. Exhaust fumes can cause death.
10. If the engine operates erratically, stop the engine immediately.
11. Do not leave equipment in the raised position.
12. Do not operate the Commercial Mower or any attachments while under the influence of alcohol, medication, controlled substances or when tired.
13. Do not operate near ditches, holes, embankments or any other terrain which may collapse under machine weight. The risk of machine tip-over increases when the ground is loose or wet.
14. When working in cooperation with other operators, always let others know what you are doing ahead of time.
15. Never try to mount or dismount from a moving unit.
16. Do not operate the Commercial Mower with bare feet. Keep hands, feet and clothing away from power-driven parts.
17. Do not drive the machine on streets or highways. Watch for traffic when you cross roads or operate near roads.
18. Look to the rear before and when backing. You must disengage blades before shifting into reverse. Make sure that the area immediately behind you is clear of obstructions or holes and small children. Use extra caution when the machine is equipped with a grass catcher.
19. Do not cross gravel roads with the PTO engaged.
20. Do not operate the mower deck without locking the hood and seat.
21. Disengage power to the mower deck when transporting or when not in use.
22. Disengage power to the mower deck before backing up. Do not mow in reverse unless absolutely necessary and then only after careful observation of the entire area behind the mower deck.
23. When mowing proceed as follows:
 - a. Mow only in daylight or in good artificial light.
 - b. Never make a cutting height adjustment while the engine is running if the operator must dismount to do so.
 - c. Check the blade mounting bolts for proper tightness at frequent intervals.
 - d. Shut off the engine when removing the grass catcher or clearing the chute.
24. Watch for holes in the terrain and other hidden hazards.
25. Do not stop or start suddenly when going uphill or downhill. Mow up and down the face of steep slopes, never cross the face.
26. Disengage power to attachment(s) and stop the engine before leaving the operators position.
27. Never leave equipment in the raised position.
28. Always keep the discharge side of the cutter directed away from people and objects which could be struck by debris thrown from the cutter.
29. Install Commercial Mower weights to increase stability when operating on slopes.

SAFETY PRECAUTIONS

30. Avoid quick stops especially when the mower deck is raised. Quick stops will cause upset.
31. Keep all shields in place.
32. Replace safety and warning decals when they become illegible.
33. The vehicle and attachments should be stopped and inspected for damage after striking a foreign object and the damage should be repaired before restarting and operating equipment.
34. Do not lubricate or make mechanical adjustments while the unit is in motion or when the engine is running. However, if minor engine adjustments must be made, apply the parking brake securely, block the wheels and use extreme caution.
35. Periodically maintain the mower deck. Tighten nuts, bolts and fittings periodically for safe operation. Check the blade for tightness.
4. Maintain control of the fuel filler pipe nozzle when filling the tank.
5. Do not fill the fuel tank to capacity. Allow room for expansion.
6. Wipe up spilled fuel immediately.
7. Always tighten the fuel tank cap securely.
8. If the original fuel tank cap is lost, replace it with an approved cap. A non-approved, proprietary cap may not be safe.
9. Keep equipment clean and properly maintained.
10. Do not drive equipment near open fires.
11. Never use fuel for cleaning purposes.
12. Arrange fuel purchases so that winter grade fuels are not held over and used in the Spring.

DIESEL FUEL

1. Under no circumstances should gasoline, alcohol or blended fuels be added to diesel fuel. These combinations can create an increased fire or explosive hazard. Such blends are more explosive than pure gasoline in a closed container such as a fuel tank. Do not use these blends.
2. Never remove the fuel cap or refuel with the engine running or hot.
3. Do not smoke while refuelling or when standing near fuel.

AVOID HIGH-PRESSURE FLUIDS

Escaping fluid under pressure can penetrate the skin causing serious injury. Relieve pressure before disconnecting hydraulic or other lines. Tighten all connections before applying pressure. Keep hands and body away from pinholes and nozzles which eject fluids under high pressure. Use a piece of cardboard to search for leaks.

If ANY fluid is injected into the skin it must be surgically removed within a few hours by a doctor familiar with this type of injury or gangrene may result.

Whenever you see this symbol  it means: **WARNING!**
BECOME ALERT! YOUR SAFETY IS INVOLVED!

SAFETY PRECAUTIONS

Safety is NO accident

Be alert!



This symbol is used to attract your attention to the safety precautions that should be understood by the operator to avoid accidents.

When you see this symbol - HEED ITS WARNING!

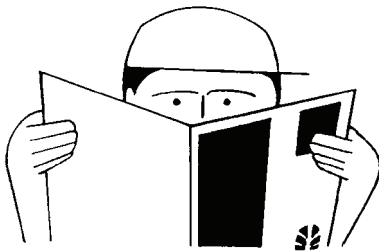

- Be sure to read all instructions before operation.
- Use the approved standard Roll Over Protective Structure (ROPS) and seat belt at all times.

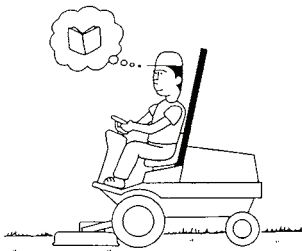

- Improper use of the Commercial Mower can result in injury. Give complete and undivided attention to the work you are doing.
- Know your controls. Know how to stop the unit and engine in an emergency.

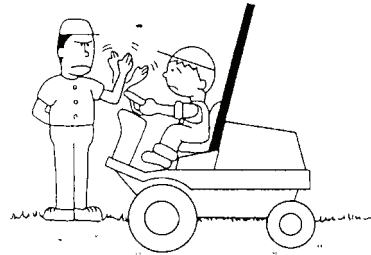

- Do not allow children to operate the Commercial Mower. Anyone else should be properly instructed as to its operation.
- Keep children and pets away. Children and pets should be kept a safe distance away from the mower.
- Stop operation when another person approaches.

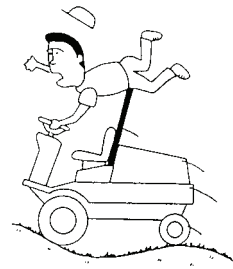

- Reduce speed on all side slopes and sharp turns to prevent tipping or losing control.

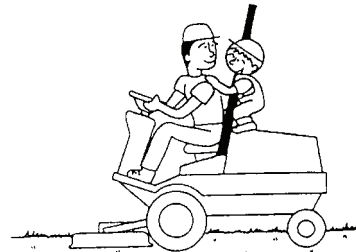

- Do not allow anyone to ride on the unit or any of its attachments.

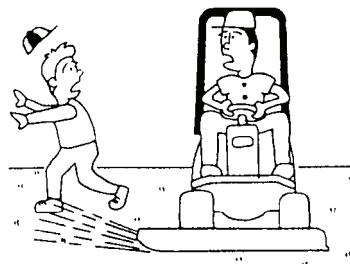

- Never allow the mower to discharge grass towards anyone.

SAFETY PRECAUTIONS

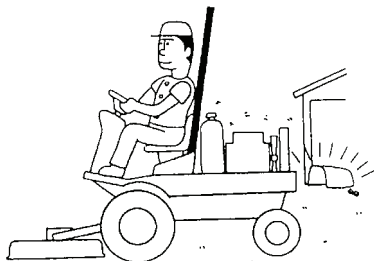

- All guards must be in place before operating the unit.
- If safety decals become illegible, they should be replaced.
- Make certain the unit or mower deck cannot be started by unauthorized persons before leaving the unit.

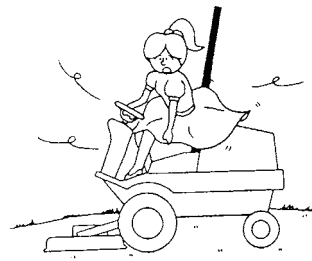

- Do not wear loose fitting clothing that might get caught in mowing parts. Also, keep hands and feet away from moving parts.
- Wear and use any additional safety items such as hard hat, safety boots or shoes, eye and hearing protection, gloves, etc., as appropriate or required.

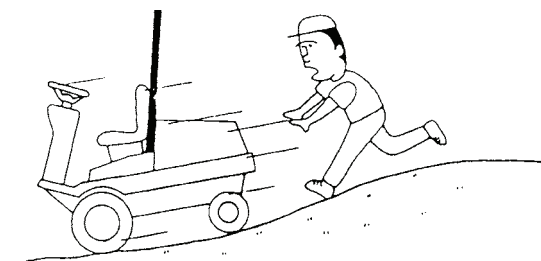

- Set the parking brake and stop the engine before leaving the seat.



- Stop engine before working on mower deck. Stop engine before cleaning discharge chute or making any adjustment, inspection or repairs.
- Periodically maintain the mower. Tighten nuts, bolts and fittings periodically and lubricate the mower for proper and safe operation. Check blades for tightness.

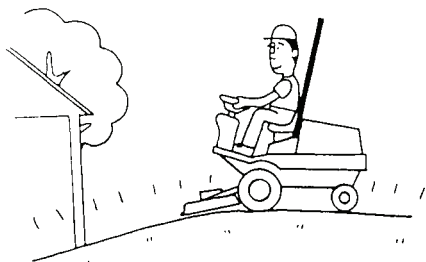

- Be sure the lawn is clean. Remove stones, wires, sticks, toys or anything that might catch or be thrown by the mower blade.

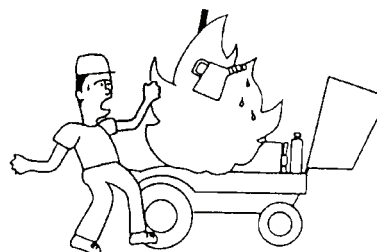

- Never remove the fuel cap or refuel with the engine running or hot. Do not smoke while refuelling or standing near fuel. Wipe up spilled fuel immediately.

SAFETY PRECAUTIONS

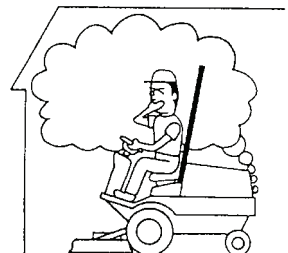

- Do not operate the Commercial Mower in a confined area. Exhaust fumes are dangerous. Only run the engine out of doors.

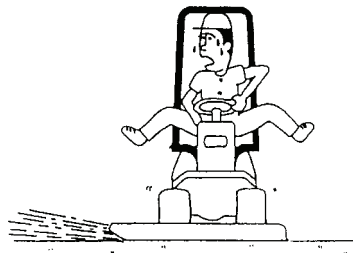

- Disengage all clutches and place gear shift in neutral before attempting to start engine.
- The discharge guard must be down at all times during mowing operation.
- If the mower strikes a foreign object, stop the mower and engine immediately. Inspect the mower deck for damage. Repair any damage before starting again.

DECALS

If safety or instruction decals become damaged or illegible, new decals should be obtained from your New Holland Dealer and placed at their original positions.

⚠ WARNING	
FAILURE TO FOLLOW SAFE OPERATING PROCEDURES MAY RESULT IN INJURY.	
1. READ OPERATOR'S MANUAL.	6. IF MACHINE STOPS GOING UPHILL
2. KNOW LOCATION AND FUNCTION OF ALL CONTROLS.	DISENGAGE P. T. O. AND BACK SLOWLY DOWN.
3. BEFORE LEAVING OPERATOR'S POSITION:	7. LOOK TO REAR BEFORE BACKING UP.
A. SET PARKING BRAKE.	8. REMOVE OBJECTS THAT COULD BE THROWN BY ROTATING BLADES.
B. SHUT ENGINE OFF AND REMOVE KEY.	9. NEVER CARRY CHILDREN KEEP PEOPLE AND PETS A SAFE DISTANCE AWAY FROM MACHINE.
4. WAIT FOR ALL MOVEMENT TO STOP BEFORE SERVICING MACHINE.	10. KEEP GUARDS AND SAFETY DEVICE IN PLACE AND WORKING.
5. DO NOT OPERATE MACHINE WHERE IT COULD TIP OR SLIP.	
<small>REPLACEMENT MANUALS ARE AVAILABLE FROM YOUR DEALER</small>	
OPERATING INSTRUCTION	
TO START	
1. SIT IN SEAT.	8. MOVE THROTTLE LEVER TO MEDIUM POSITION AND ALLOW ENGINE TO WARM UP.
2. PLACE SHIFT LEVER IN NEUTRAL.	TO STOP
3. PLACE P. T. O. CLUTCH LEVER IN OFF.	TURN KEY TO OFF POSITION.
4. PUT THROTTLE LEVER TO FULL SPEED POSITION.	NOTE
5. PRESS BRAKE PEDAL, OR PULL PARKING BRAKE.	ENGINE STOPS IF OPERATOR LEAVES SEAT WITH P. T. O. ON AND/OR DRIVE LINE ENGAGED AND/OR PARKING BRAKE IS NOT ENGAGED.
6. TURN KEY TO HEAT POSITION AND HOLD UNTIL SIGNAL LAMP GOES OFF.	
7. TURN KEY TO START POSITION AND HOLD UNTIL ENGINE STARTS, THEN RELEASE KEY.	
<small>390197760</small>	

WARNING: SAFE OPERATING PROCEDURES

PART NO: SBA 390197760
 LOCATION: On the L.H. Fender

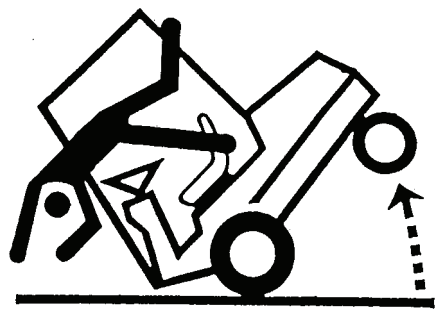
⚠ WARNING

AVOID QUICK STOPS
<ul style="list-style-type: none"> ● MOVE VERY SLOWLY WHEN ATTACHMENT IS REMOVED ● KEEP ATTACHMENT LOW WHEN TRANSPORTING ● REDUCE SPEED ON SLOPES
<small>390195260</small>

WARNING: AVOID QUICK STOPS

PART NO: SBA 390195261
 LOCATION: On the Fender Under Seat

⚠ WARNING
KEEP HANDS AND CLOTHING AWAY FROM ROTATING FAN AND BELTS TO PREVENT SERIOUS INJURY

WARNING: KEEP HANDS AND CLOTHING

PART NO: SBA 390191352
 LOCATION: On the Cover of Cooling Fan

SAFETY DECALS

! DANGER



<p>CAN CAUSE BLINDNESS OR SEVERE INJURY. Protect eyes. Sparks, flames, cigarettes can cause EXPLOSION: Tools and cable clamps can cause sparks. Do not use without instruction.</p>	<p>Keep vent caps tight and level. CAUSES SEVERE BURNS. Contains sulfuric acid. In event of contact, flush with water and see a doctor. KEEP OUT OF REACH OF CHILDREN.</p>
--	---

DANGER: EXPLOSIVE/ACID - POISON

PART NO: SBA 390194390

LOCATION: Top of Battery

! DANGER

 <ul style="list-style-type: none"> • When improperly operated a CM tractor can rollover or upset. • For low clearance use only the ROPS can be lowered. No protection is provided in the lowered position. 	<ul style="list-style-type: none"> • Raise ROPS immediately after low clearance use, or for transport. • When ROPS is lowered, use of seat belt is not recommended. 	 <ul style="list-style-type: none"> • Do not attach ropes or chains to ROPS for pulling purposes. Use of ROPS and seat belt reduce the chance of injury or death if rollover or upset occurs.
--	---	---

DANGER

PART NO: SBA 390195520

LOCATION: On the ROPS

LUBRICATION AND MAINTENANCE

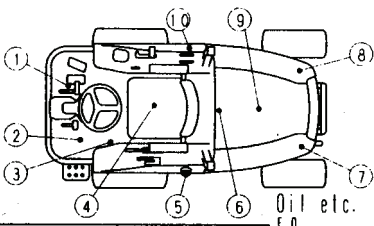

	Lubrication and Maintenance Items	Oil etc.	Capacity (l)	Check intervals (h)	Change intervals (h)	Service points
1	Pedal shaft	C. G.		50		2
2	Lift arm	C. G.		50		2
3	Lift cylinder	C. G.		50		4
4	Transmission oil	H. O.	20	50	600	1
5	Fuel tank	F.	50	before starting		1
6	Radiator	C.	5	before starting		1
7	Steering cylinder	C. G.		50		2
8	Rear Axle 4WD	H. O.	2	100	600	1
9	Engine oil	E. O.	5	5	100	1
10	Battery	D. W.	25	25		6

Oil etc.
 E. O. Diesel engine oil
 All season SAE10W/30
 -5°C-25°C
 23°F-77°F
 SAE20W
 10°C-35°C
 50°F-95°F
 SAE30
 H. O. Hydraulic System and Gear oil
 ISO VG46
 C. G. Chassis grease or Universal grease No. 2
 F. Diesel fuel oil
 C-LLC
 D. W. Distilled water
 NOTE
 Change engine oil and HYD. oil at first 50 hours.

Also Oil other pins and links as necessary.
 Capacity of the Engine oil and Radiator coolant for M28.35 are 5 and 5 liters.

LUBRICATION AND MAINTENANCE

PART NO: SBA 390211740

LOCATION: Underside of Hood

INSTRUCTION DECALS

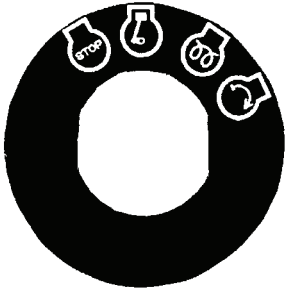

STARTER SWITCH

PART NO: SBA 390197280
LOCATION: On the R.H. of Dash



PARKING BRAKE

PART NO: SBA 390197710
LOCATION: On the L.H. Fender

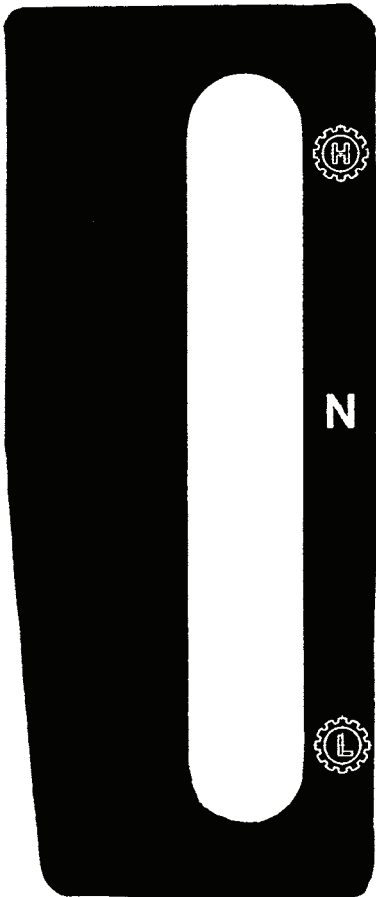

RANGE SELECT LEVER 2WD

PART NO: SBA 390173670
LOCATION: On the L.H. Fender

**RANGE SELECT AND
FWD CONTROL LEVER**

PART NO: SBA 390173650
LOCATION: On the L.H. Fender

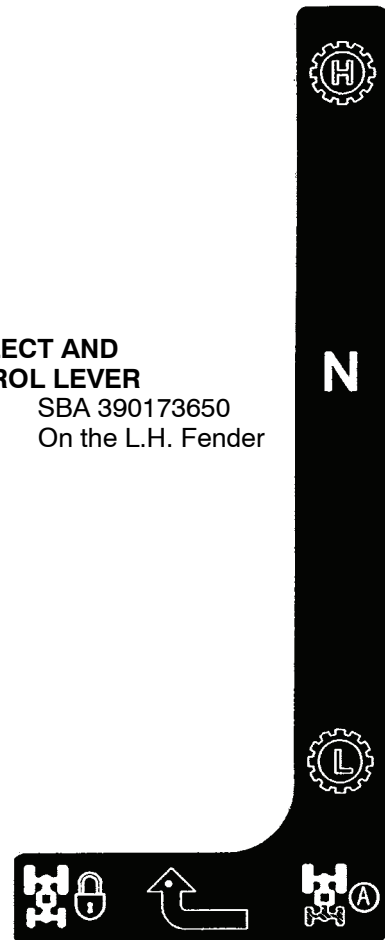

INSTRUCTION DECALS

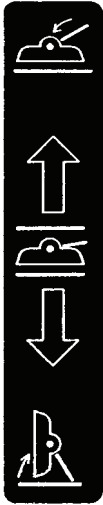

LIFT CONTROL LEVER
 PART NO: SBA 390372400
 LOCATION: On the R.H. Fender



PTO CONTROL LEVER
 PART NO: SBA 390173600
 LOCATION: On the R.H. Fender

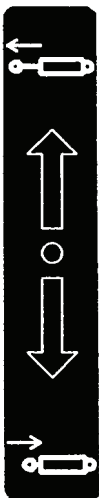

REMOTE VALVE LEVER (OPT) (Auxiliary)
 PART NO: SBA 390372410
 LOCATION: On the R.H. Fender

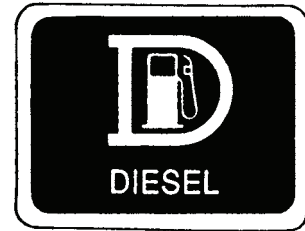

DIESEL FUEL
 PART NO: SBA 490991160
 LOCATION: Near the Filler Cap

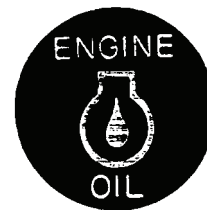

ENGINE OIL
 PART NO: SBA 390230120
 LOCATION: On Engine Oil Filler Cap



DIFFERENTIAL LOCK
 PART NO: SBA 390191690
 LOCATION: On Dash Near Pedal

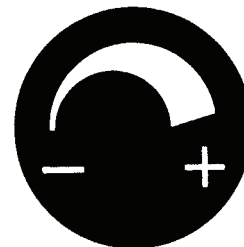

WEIGHT TRANSFER
 PART NO: SBA 390372000
 LOCATION: On the Weight Transfer Knob

PLEASE READ CAREFULLY:

For a complete list of the predelivery service checks performed by your dealer, refer to the PREDELIVERY SERVICE checklist found at the back of this manual. Keep one copy as your record of the service performed. The other copy should be removed from the manual and kept by your dealer. **MAKE SURE THAT BOTH COPIES ARE COMPLETED AND THAT YOU AND THE DEALER SIGN BOTH COPIES.**

A **PRODUCT IDENTIFICATION PLATE** is located in the front transmission case under the front body of the mower.

The numbers on the plate are important in the event your mower should require future service. For your convenience, have your dealer record these numbers in the appropriate spaces below.

New Holland North America, Inc. is continually striving to improve its products. We reserve the right to change prices, specification, or equipment at any time without notice.

All data given in this book is subject to production variations. Dimensions and weights are approximate only, and the illustrations do not necessarily depict the mower in standard condition. For exact information about any particular mower, please consult your New Holland dealer.

This mower has been designed for doing light work, such as mowing, blowing snow. Do not attempt to use implements that were not designed for this mower, as they may cause damage to the mower.

TRACTOR NUMBER		MODEL
*	*	
ENGINE		UNIT
*	*	
NEW HOLLAND NORTH AMERICA, INC.		
MADE IN JAPAN		



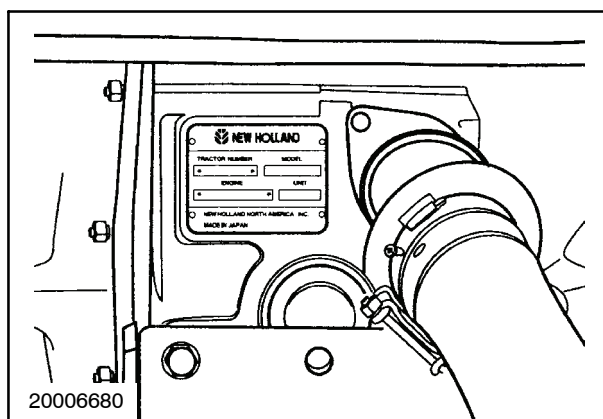





























1



2

INTERNATIONAL SYMBOLS

As a guide to the operation of your Commercial Mower, various universal symbols have been utilized on the instruments and controls. The symbols are depicted and described below.

	Hours Recorded	N	Neutral		Battery
	Engine Water Temperature		Diesel Fuel		Power Take-Off (ON)
	Air Filter		Glow Plugs		Power Take-Off (OFF)
	Engine Oil Pressure		Engine Stop		"Tortoise" - Slow or Minimum Setting
	Full Time 4WD		Engine Oil		"Hare" - FAST or Maximum Setting
	Auto 4WD		Engine Start		Warning
	Continuously Variable		Parking Brake		Control Lever Hold
	Increase		Lock		Rock Shaft (Raised)
	Decrease		Lock Release		Rock Shaft (Lowered)
	Fuel Level		Differential Lock		Remote Cylinder (Retracted)
	High Range		Volume Empty		Remote Cylinder (Extended)
	Low Range		Volume Full		

SPECIFICATIONS

ENGINE	MC22	MC28	MC35
Type	Diesel	Diesel	Diesel
Engine Gross Horsepower	21.5	28	35
Cylinders	3	3	3
Bore	77 mm (3.03")	84 mm (3.31")	84 mm (3.31")
Stroke	72 mm (2.83")	80 mm (3.15")	100 mm (3.94")
Displacement	61.3 cu. in. (1.005 liters)	81.2 cu. in. (1.330 liters)	101.4 cu. in. (1.662 liters)
Compression Ratio	23 : 1	22.5 : 1	22.5 : 1
Firing Order	1-2-3	1-2-3	1-2-3
Low Idle Speed	1000 RPM	1000 RPM	1000 RPM
Maximum Speed:			
High Idle	2940 RPM	2940 RPM	2940 RPM
Rated	2700 RPM	2700 RPM	2700 RPM
Valve Clearance (Cold):			
Intake	0.20 mm (0.008")	0.20 mm (0.008")	0.20 mm (0.008")
Exhaust	0.20 mm (0.008")	0.20 mm (0.008")	0.20 mm (0.008")
CAPACITIES			
Fuel Tank	13.3 U.S. gal. (50.5 liters)	13.3 U.S. gal. (50.5 liters)	13.3 U.S. gal. (50.5 liters)
Cooling System	4.4 U.S. qt. (4.2 liters)	5.3 U.S. qt. (5.1 liters)	5.6 U.S. qt. (5.3 liters)
Engine Crankcase:			
Less Filter	3.5 U.S. qt. (3.3 liters)	5.5 U.S. qt. (5.2 liters)	5.7 U.S. qt. (5.4 liters)
With Filter Change	3.7 U.S. qt. (3.5 liters)	6.0 U.S. qt. (5.7 liters)	6.0 U.S. qt. (5.7 liters)
Front Axle & Transmission (Includes Hydraulics)	5.8 U.S. gal. (22.0 liters)	5.8 U.S. gal. (22.0 liters)	5.8 U.S. gal. (22.0 liters)
Rear Axle Center Case & Final Case	2.4 U.S. qt. (2.3 liters)	2.4 U.S. qt. (2.3 liters)	2.4 U.S. qt. (2.3 liters)

SECTION 00 - GENERAL INFORMATION

COOLING SYSTEM	MC22	MC28	MC35
Type	Pressurized Liquid w/Recirculating Bypass	Pressurized Liquid w/Recirculating Bypass	Pressurized Liquid w/Recirculating Bypass
Water Pump:			
Type	Centrifugal	Centrifugal	Centrifugal
Drive	V-Belt	V-Belt	V-Belt
Belt Deflection	7/16"-9/16" (10 mm-15 mm) when 20-25 lbs. (9-11 kg) thumb pressure is applied midway between belt pulleys	7/16"-9/16" (10 mm-15 mm) when 20-25 lbs. (9-11 kg) thumb pressure is applied midway between belt pulleys	7/16"-9/16" (10 mm-15 mm) when 20-25 lbs. (9-11 kg) thumb pressure is applied midway between belt pulleys
Fan Diameter	305 mm (12.0")	340 mm (13.4")	360 mm (14.2")
Thermostat:			
Start to Open	160° F (71° C)	160° F (71° C)	160° F (71° C)
Fully Open	185° F (85° C)	185° F (85° C)	185° F (85° C)
Radiator Cap	13 PSI (0.9 bar)	13 PSI (0.9 bar)	13 PSI (0.9 bar)
ELECTRICAL SYSTEM			
Alternator	12-volt, Heavy Duty, 40 amps		
Battery	12-volt, 53.9 amp hour rating w/ negative ground, 490 CCA		
Starting Motor	Solenoid Pre-Engaged Reduction		
FUEL SYSTEM			
Fuel Type	Diesel	Diesel	Diesel
Type of Fuel to Use if Above 40°F	No.2 - Diesel Cetane Rating: Minimum 40	No.2 - Diesel Cetane Rating: Minimum 40	No.2 - Diesel Cetane Rating: Minimum 40
Type of Fuel to Use if Below 40°F	No.1 - Diesel Cetane Rating: Minimum 40	No.1 - Diesel Cetane Rating: Minimum 40	No.1 - Diesel Cetane Rating: Minimum 40
Injection Pump:			
Type	In Line	In Line	In Line
Timing	21.0° BTDC	21.0° BTDC	18.0° BTDC

SECTION 00 - GENERAL INFORMATION

BRAKES	MC22	MC28	MC35
Type		Wet Disc Final Brake	
Disc 2 Diameter	6.1" x 4.84" 155 mm x 123 mm	6.1" x 4.84" 155 mm x 123 mm	6.1" x 4.84" 155 mm x 123 mm

STEERING

Type	Tilt Telescopic Hyd Power		
Lock-to-Lock:			
2WD	R 1.9 L 2.3		
FWD	R 2.1 L 2.5		
Toe-in	0 - 5 mm (0" - 13/64")	0 - 5 mm (0" - 13/64")	0 - 5 mm (0" - 13/64")
Turning Radius			
Inside Front Tire (w/o Brakes)			
2WD	730 mm (28.7")	730 mm (28.7")	
FWD	750 mm (29.5")	750 mm (29.5")	750 mm (29.5")

POWER TAKE-OFF

Type	Wet multi plates	Wet multi plates	Wet multi plates
Shaft PTO	25.4 mm (1")	25.4 mm (1")	25.4 mm (1")
Engine Speed @ 2700 RPM			
PTO RPM	2209 RPM	2209 RPM	2209 RPM
Horsepower PTO			
Observed	15.0	20.0	24.5

HYDRAULIC LIFT SYSTEM

Type	Open Center	Open Center	Open Center
Pump Type	Gear	Gear	Gear
Pump Capacity	1.90 U.S. gpm (7.2 l/min)	2.40 U.S. gpm (9.1 l/min)	2.40 U.S. gpm (9.1 l/min)
at Eng 2700 RPM			
System Relief Valve	1471 PSI	1471 PSI	1471 PSI
Setting	(100 bar)	(100 bar)	(100 bar)

TRANSMISSION

Type	HST with 2 Range Gear Drive		
4WD Drive	Auto 4WD or Full 4WD		
Speed			
With STD Tire at 2700 RPM Engine Speed			
Gear position:			
Forward ; L	0-6.03 MPH (0-9.7 Km/h)	0-6.03 MPH (0-9.7 Km/h)	0-6.03 MPH (0-9.7 Km/h)
Forward ; H	0-10.3 MPH (0-16.6 Km/h)	0-10.3 MPH (0-16.6 Km/h)	0-10.3 MPH (0-16.6 Km/h)
Reverse ; L		60%-70% of Forward Speeds	
Reverse ; H		60%-70% of Forward Speeds	
With Large tire at 2700 RPM Engine Speed			
Gear Position:			
Forward ; L	0-6.21 MPH (0-10.0 Km/h)	0-6.21 MPH (0-10.0 Km/h)	0-6.21 MPH (0-10.0 Km/h)
Forward ; H	0-10.7 MPH (0-17.2 Km/h)	0-10.7 MPH (0-17.2 Km/h)	0-10.7 MPH (0-17.2 Km/h)
Reverse ; L		60%-70% of Forward Speeds	
Reverse ; H		60%-70% of Forward Speeds	

SECTION 00 - GENERAL INFORMATION

CAST IRON WEIGHTS	MC22	MC28	MC35
Front Wheel		75 lbs. (34 Kg)	
Rear End		60 lbs. (27 kg)	
TIRES (Turf)			
FRONT; STD			
2WD	23 x 10.50-12 4PR	23 x 10.50-12 4PR	-----
FWD	23 x 10.50-12 4PR	23 x 10.50-12 4PR	23 x 10.50-12 4PR
REAR:			
2WD	20 x 8.00-10 4PR	20 x 8.00-10 4PR	-----
FWD	20 x 8.00-10 4PR	20 x 8.00-10 4PR	20 x 8.00-10 4PR
FRONT; Large			
2WD	24 x 13.00-12 4PR	24 x 13.00-12 4PR	-----
FWD	24 x 13.00-12 4PR	24 x 13.00-12 4PR	24 x 13.00-12 4PR
REAR (for Large)			
2WD	20 x 8.00-10 4PR	20 x 8.00-10 4PR	-----
FWD	20 x 8.00-10 4PR	20 x 8.00-10 4PR	20 x 8.00-10 4PR
WHEEL BOLT TORQUES			
Front; STD	148-116 N·m (97 ± 11 ft.-lb.)	148-116 N·m (97 ± 11 ft.-lb.)	148-116 N·m (97 ± 11 ft.-lb.)
Front; Large	148-116 N·m (97 ± 11 ft.-lb.)	148-116 N·m (97 ± 11 ft.-lb.)	148-116 N·m (97 ± 11 ft.-lb.)
Rear	56-44 N·m (37 ± 4.4 ft.-lb.)	56-44 N·m (37 ± 4.4 ft.-lb.)	56-44 N·m (37 ± 4.4 ft.-lb.)
ROPS ATTACHING BOLT TORQUES			
ROPS to Lower ROPS	157 ± 9.8 N·m (116 ± 7.2 ft.-lb.)	157 ± 9.8 N·m (116 ± 7.2 ft.-lb.)	157 ± 9.8 N·m (116 ± 7.2 ft.-lb.)
Seat Belt	50 ± 5.9 N·m (37 ± 4.4 ft.-lb.)	50 ± 5.9 N·m (37 ± 4.4 ft.-lb.)	50 ± 5.9 N·m (37 ± 4.4 ft.-lb.)
ROPS to Frame	97 N·m (72 ft.-lb.)	97 N·m (72 ft.-lb.)	97 N·m (72 ft.-lb.)
WHEEL TREAD SETTINGS			
FRONT:			
STD Tire 2WD & FWD			
Dished In	940 mm (37.00")	940 mm (37.00")	940 mm (37.00")
Dished Out	1100 mm (43.30")	1100 mm (43.30")	1100 mm (43.30")
Large Tire 2WD & FWD			
Dished In	990 mm (38.97")	990 mm (38.97")	990 mm (38.97")
Dished Out	1050 mm (41.34")	1050 mm (41.34")	1050 mm (41.34")
REAR: STD & Large			
2WD	990 mm (38.97")	990 mm (38.97")	-----
FWD	995 mm (39.17")	995 mm (39.17")	995 mm (39.17")

SECTION 00 - GENERAL INFORMATION

WEIGHT	MC22	MC28	MC35
Std Tires with ROPS:			
2WD	1499 lbs. (680 kg)	1543 lbs. (700 kg)	-----
FWD	1543 lbs. (700 kg)	1609 lbs. (730 kg)	1653 lbs. (750 kg)
Large Tire With ROPS			
2WD	1521 lbs. (690 kg)	1565 lbs. (710 kg)	-----
FWD	1565 lbs. (710 kg)	1631 lbs. (740 kg)	1675 lbs. (760 kg)

SECTION 00 - GENERAL INFORMATION

GENERAL DIMENSION	MC22	MC28	MC35
(1) LENGTH 2WD & FWD	2415 mm (95.1")	2415 mm (95.1")	2415 mm (95.1")
(2) WHEEL BASE 2WD & FWD	1250 mm (49.2")	1250 mm (49.2")	1250 mm (49.2")
(3) HEIGHT Center of Steering Wheel (return position) STD Tire	1390 mm (54.7")	1390 mm (54.7")	1390 mm (54.7")
(4) Top of ROPS STD Tire:			
Up Position	1930 mm (75.98")	1930 mm (75.98")	1930 mm (75.98")
Down Position	1225 mm (48.22")	1225 mm (48.22")	1225 mm (48.22")
Large Tires:			
Up Position	1935 mm (76.18")	1935 mm (76.18")	1935 mm (76.18")
Down Position	1225 mm (48.22")	1225 mm (48.22")	1225 mm (48.22")

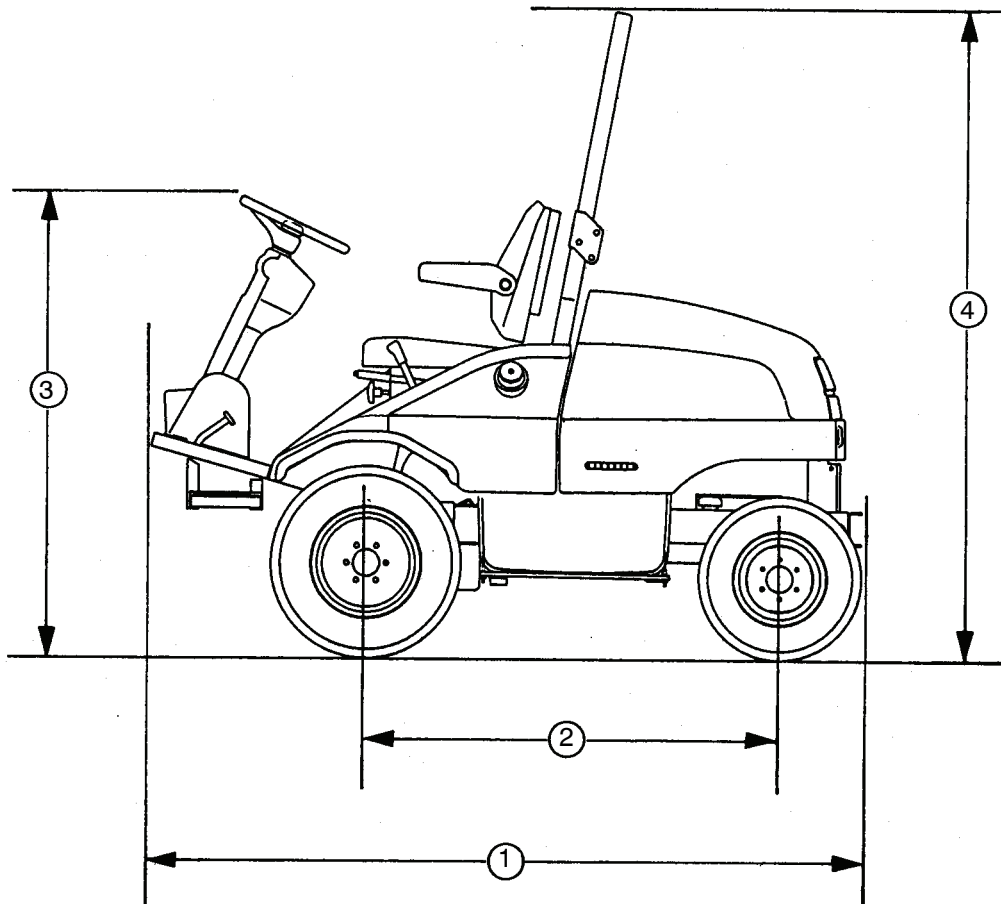

SECTION 00 - GENERAL INFORMATION

(5) WIDTH

Rear Axle Outside to Outside:

2WD Dished In only	1185 mm (46.65")	1185 mm (46.65")	-----
FWD Dished In only	1190 mm (46.85")	1190 mm (46.85")	1190 mm (46.85")

Front Axle Outside to Outside:

STD Tire 2WD & FWD			
Dished In	1220 mm (48.03")	1220 mm (48.03")	1220 mm (48.03")
Dished Out	1370 mm (53.93")	1370 mm (53.93")	1370 mm (53.93")
Large Tire			
Dished In	1310 mm (51.57")	1310 mm (51.57")	1310 mm (51.57")
Dished Out	1370 mm (53.93")	1370 mm (53.93")	1370 mm (53.93")

(6) MINIMUM GROUND CLEARANCE

STD Tires	140 mm (5.51")	140 mm (5.51")	140 mm (5.51")
Large Tire	150 mm (5.90")	150 mm (5.90")	150 mm (5.90")

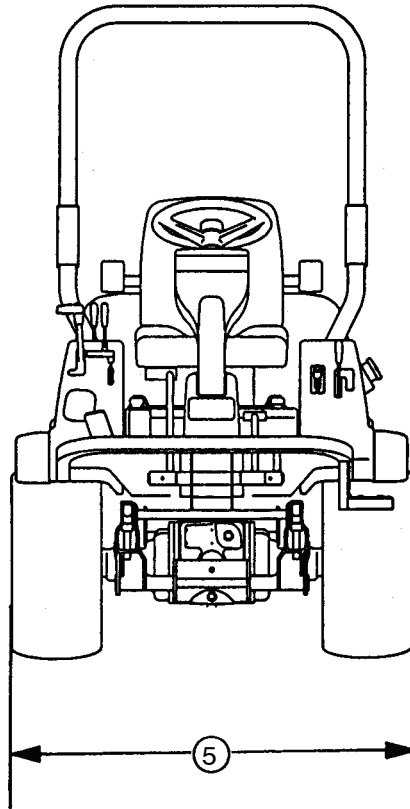

MINIMUM HARDWARE TIGHTENING TORQUES

IN FOOT POUNDS (NEWTON-METERS) FOR NORMAL ASSEMBLY APPLICATIONS

INCH HARDWARE AND LOCKNUTS

NOMINAL SIZE	SAE GRADE 2		SAE GRADE 5		SAE GRADE 8		LOCKNUTS		NOMINAL SIZE
	UNPLATED or PLATED SILVER	PLATED W/ZnCr GOLD	UNPLATED or PLATED SILVER	PLATED W/ZnCr GOLD	UNPLATED or PLATED SILVER	PLATED W/ZnCr GOLD	GR.B w/GR5 BOLT	GR.C w/GR8 BOLT	
1/4	55* (6.2)	72* (8.1)	86* (9.7)	112* (13)	121* (14)	157* (18)	61* (6.9)	86* (9.8)	1/4
5/16	115* (13)	149* (17)	178* (20)	229* (26)	250* (28)	324* (37)	125* (14)	176* (20)	5/16
3/8	17 (23)	22 (30)	26 (35)	34 (46)	37 (50)	48 (65)	19 (26)	26 (35)	3/8
7/16	27 (37)	35 (47)	42 (57)	54 (73)	59 (80)	77 (104)	30 (41)	42 (57)	7/16
1/2	42 (57)	54 (73)	64 (87)	83 (113)	91 (123)	117 (159)	45 (61)	64 (88)	1/2
9/16	60 (81)	77 (104)	92 (125)	120 (163)	130 (176)	169 (229)	65 (88)	92 (125)	9/16
5/8	83 (112)	107 (145)	128 (174)	165 (224)	180 (244)	233 (316)	90 (122)	127 (172)	5/8
3/4	146 (198)	189 (256)	226 (306)	293 (397)	319 (432)	413 (560)	160 (217)	226 (306)	3/4
7/8	142 (193)	183 (248)	365 (495)	473 (641)	515 (698)	667 (904)	258 (350)	364 (494)	7/8
1	213 (289)	275 (373)	547 (742)	708 (960)	773 (1048)	1000 (1356)	386 (523)	545 (739)	1

NOTE: Torque values shown with * are inch pounds.

IDENTIFICATION CAP SCREWS AND CARRIAGE BOLTS



LOCKNUTS

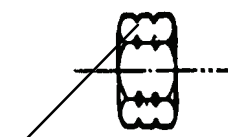

GRADE IDENTIFICATION
 GRADE A NO NOTCHES
 GRADE B ONE CIRCUMFERENTIAL NOTCH
 GRADE C TWO CIRCUMFERENTIAL NOTCHES

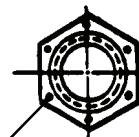

GRADE IDENTIFICATION
 GRADE A NO MARKS
 GRADE B THREE MARKS
 GRADE C SIX MARKS
 MARKS NEED NOT BE LOCATED AT CORNERS

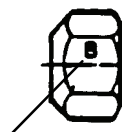

GRADE IDENTIFICATION

GRADE A NO MARK
 GRADE B LETTER B
 GRADE C LETTER C

MINIMUM HARDWARE TIGHTENING TORQUES

IN FOOT POUNDS (NEWTON-METERS) FOR NORMAL ASSEMBLY APPLICATIONS

METRIC HARDWARE AND LOCKNUTS

NOMINAL SIZE	CLASS 5.8		CLASS 8.8		CLASS 10.9		LOCKNUT CL.8 W/CL8.8 BOLT
	UNPLATED	PLATED W/ZnCr	UNPLATED	PLATED W/ZnCr	UNPLATED	PLATED W/ZnCr	
M4	15* (1.7)	19* (2.2)	23* (2.6)	30* (3.4)	33* (3.7)	42* (4.8)	16* (1.8)
M6	51* (5.8)	67* (7.6)	79* (8.9)	102* (12)	115* (13)	150* (17)	56* (6.3)
M8	124* (14)	159* (18)	195* (22)	248* (28)	274* (31)	354* (40)	133* (15)
M10	21 (28)	27 (36)	32 (43)	41 (56)	45 (61)	58 (79)	22 (30)
M12	36 (49)	46 (63)	55 (75)	72 (97)	79 (107)	102 (138)	39 (53)
M16	89 (121)	117 (158)	137 (186)	177 (240)	196 (266)	254 (344)	97 (131)
M20	175 (237)	226 (307)	277 (375)	358 (485)	383 (519)	495 (671)	195 (265)
M24	303 (411)	392 (531)	478 (648)	619 (839)	662 (897)	855 (1160)	338 (458)

NOTE: Torque values shown with * are inch pounds.

IDENTIFICATION HEX CAP SCREW AND CARRIAGE BOLTS CLASSES 5.6 AND UP

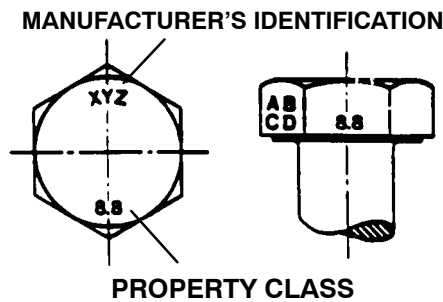

HEX NUTS AND LOCKNUTS CLASSES 05 AND UP

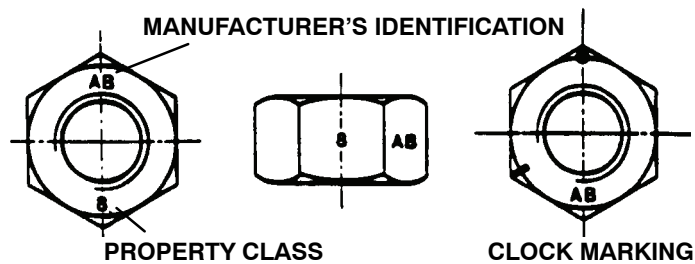

SPECIAL TOOLS

Bore Gauge	19-25 mm (0.75 - 1.0 in.)
Compression Test Adapter	FNH00120
Cylinder Bore Gauge	25-51 mm (1-2 in.)
Cylinder Bore Gauge	51-76 mm (2-3 in.)
Dial Indicator (Magnetic Base)	FNH01345
Gauge, 0-138 bar (0-2000 PSI)	FNH02504
HST High Pressure Relief Valve Test Fitting	NH01410
HST Charge Pressure Relief Valve Test Fitting	NH01411
Injector Adapter Set	FNH01728
Injector Nozzle Tester	FNH01721
Micrometer	0-25 mm (0-1 in.)
Micrometer	25-51 mm (1-2 in.)
Micrometer	51-76 mm (2-3 in.)
Oil Pressure Test Fitting	FNH00011
Oil Pump Port Block Installer Tool (MC22)	FNH11063A
Oil Pump Port Block Installer Tool (MC28 & MC35)	FNH00117
Oil Pump Port Block Removal Tool	FNH11097
Power-steering test fitting	NH01412
PTO Clutch Spring Compressor	NH01413
*Steering Motor Return Spring Installation Tool	Manufacture
Transaxle Alignment Rods	NH01414
Transaxle range fork Detent Ball Installation Tool	FNH01580

*Refer to figure below for tool manufacturing instructions.

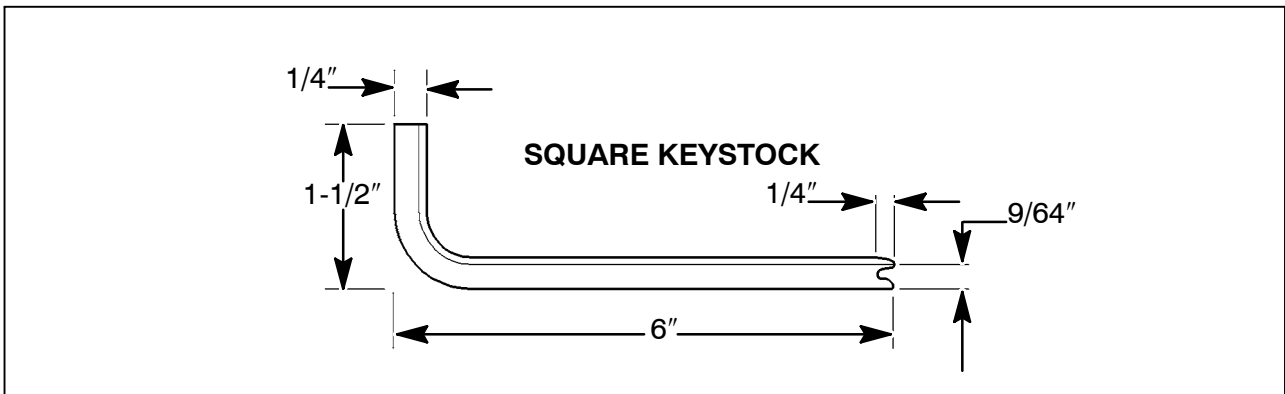

SECTION 00 - GENERAL INFORMATION

TORQUE APPLICATIONS

Charge Pump Mounting Bolts	44-55 N·m (32.5-39.8 ft. lbs.)
High Pressure Relief/ Check Valve Plugs	63.7 N·m (47.0 ft.-lbs.)
Port Block Mounting Bolts	44-55 N·m (32.5-39.8 ft.-lbs.)
Swash Plate Cover Screws	6.2-7.6 N·m (4.6-5.6 ft.-lbs.)

SECTION 00 - GENERAL INFORMATION

LUBRICANTS

Op. 00 400

LUBRICANT	TYPE	NEW HOLLAND NO.	AMOUNT
Grease	High Viscosity Lithium Base-NL GI#2	9613310 9613379 (Canada)	Tube
Oil (Engine)- API Service SG-CE	10W-30	9613313	1 quart
		9613314	2.5 gallons
		9673508DS	5 gallons
		9613358 (Canada)	1 liter
		9613360 (Canada)	20 liters
	15W-40	9613290	1 quart
		9613303	2.5 gallons
		9613350 (Canada)	1 liter
		9613352 (Canada)	20 liters
		9613292	5 gallons
	SAE 30	9613286	1 quart
		9613289	2.5 gallons
		9613366 (Canada)	4 liters
	5W-30	9673589DS	1 quart
Oil (Hydraulic System) - Transmission, Front Axle, Rear FWD Axle, Power Steering	NH 134D	9624655DS	1 quart
		9624656DS	1 gallon
		9624450	2.5 gallons
		9624451	5 gallons
		9613368 (Canada)	20 liters
	NH F200 (OPTIONAL) Multi-Seasonal Use, Recommended for Low Temperature Conditions	86523625DS	1 gallon
		86523626DS	5 gallons
		86509446 (Canada)	20 liters

SECTION 00 - GENERAL INFORMATION

TOUCH-UP PAINT

Color	Part No.	Amount
Blue Acrylic	9613385-DS 9613386-DS	16 oz. Spray Quart
Chassis Gray	9624696-DS 9624697-DS	16 oz. Spray Quart
Bianco White (Wheels)	9624698-DS 9624699-DS	16 oz. Spray Quart
Med Glass Black	94792-DS 9624700-DS	16 oz. Spray Quart

Op. 00 100

PRE-SEASON AND PREDELIVERY SERVICE

CHECK AND ADJUST AS REQUIRED

INOPERATIVE SERVICE CHECKS

1. ___ Tire Pressure
2. ___ Air Cleaner Element & Hose Connections
3. ___ Radiator Coolant Level
4. ___ Fan Belt Tension
5. ___ Battery Cleanliness, Vent Openings, Electrolyte Level, & Charge
6. ___ Engine Oil Level
7. ___ Power Steering Reservoir Oil Level
8. ___ Transmission & Front Axle Oil Level
9. ___ Rear Axle & Final Reduction Gear Case Oil Level (FWD)
10. ___ Rear Wheel Bolt Torque - 50 N·m (37 ft.-lb.)
11. ___ Front Wheel Bolt Torque -132 N·m (97 ft.-lb.) (2WD & FWD)
12. ___ Rear Wheel Toe-in
13. ___ Fuel Level
14. ___ Sheet Metal & Paint Condition

SAFETY ITEMS CHECKS

1. ___ ROPS Installed
2. ___ Seat Belts Installed
3. ___ ROPS Bolt Torque-157 N·m (116 ft.-lb.)
Seat Belt Bolt Torque - 50.0 N·m (37 ft.-lb.)
4. ___ Safety Decals Installed
5. ___ Neutral Start Switches Operation
6. ___ Parking Brake & Latch Operation
7. ___ Operator's Manual

OPERATIVE SERVICE CHECKS

All operating checks are to be performed with tractor at normal operating temperature.

1. ___ Lights & Instruments for Proper Operation, & Fuel Shut Down with Key Switch OFF
2. ___ Fluid & Oil Leaks
3. ___ Maximum No-load Speed & Idle Speed Adjustments
4. ___ PTO Engagement & Disengagement PTO Lever
5. ___ Hydraulic Front Lift Operation
6. ___ FWD-Drive Lever Operation
7. ___ Operation of H.S.T.

TRACTOR MODEL NO. _____ INSPECTION PERFORMED _____

TRACTOR SERIAL NO. _____ WARRANTY EXPLAINED _____

Owner's Signature _____ Date _____

Dealer's Signature _____ Date _____

SECTION 00 - GENERAL INFORMATION

SECTION 10 - ENGINE AND FUEL SYSTEMS

Chapter 1 - Engine and Fuel Systems

CONTENTS

Section	Description	Page
	Specifications	10-3
	Torque Specifications	10-14
	Special Tools	10-15
	Engine	10-16
	Description of Operation	10-16
	Troubleshooting	10-20
	Compression Test	10-24
	Engine Overhaul	10-26
10 012	Engine Removal	10-26
	Engine Disassembly	10-31
10 106	Engine Gears and Camshaft Removal	10-37
10 102	Oil Pan and Pick-up Removal	10-38
10 102	Connecting Rods, Bearings, and Piston Removal	10-39
	Disassembly, Inspection, and Assembly of Engine Components	10-41
10 101	Cylinder Head	10-41
10 001	Cylinder Block	10-48
10 105	Pistons, Piston Rings, and Connecting Rods - Disassembly and Inspection	10-49
	Pistons, Rings, and Connecting Rod Assembly	10-56
10 103	Crankshaft	10-57
10 304	Oil Pump Port Block	10-64
	Camshaft and Timing Gears	10-65
10 103	Flywheel	10-68
	Timing Gear Housing	10-68
	Engine Assembly	10-69
10 102	Oil Pick-up and Pan Installation	10-71
10 102	Oil Pump, Idler Gear, and Injection Timing	10-72
10 101	Cylinder Head Assembly	10-73
	Engine Installation	10-77
	Lubrication System Specifications	10-83
10 304	Engine Lubrication System	10-84
10 206	Oil Filter	10-87
	Oil Pump	10-87

CONTENTS (continued)

	Engine Oil Pressure Check	10-89
	Engine Oil Relief Valve	10-90
	Oil Consumption	10-90
	Cooling System	10-91
10 400	Description of Operation	10-92
	Maintenance	10-94
	Coolant	10-94
	Radiator Cap	10-94
10 402	Thermostat	10-95
	Cooling System Overhaul	10-97
10 406	Radiator	10-97
10 402	Water Pump	10-102
10 402	Thermostat	10-108
	Fuel System	10-111
	Special Tools	10-112
	Description of Operation	10-113
10 242	Injection Pump (MC22)	10-113
	Description of Operation	10-119
10 242	Injection Pump (MC28 and MC35)	10-119
	Pumping Elements	10-124
	Delivery Valves	10-126
	Governor	10-128
10 230	Description of Operation	10-128
	Fuel Injectors	10-130
10 218	Description of Operatio	10-130
	Troubleshooting	10-132
	Fuel System Repair	10-137
10 230	Governor Disassembly	10-146
10 218	Fuel Injectors	10-154

SPECIFICATIONS

GENERAL ENGINE SPECIFICATIONS

Tractor Model	MC 22	MC 28	MC 35
Engine Model	S773	J843	N843L
Number Of Cylinders	3	3	3
Bore X Stroke	77 x 72 mm (3.03 x 2.83 in.)	84 x 80 mm (3.31 x 3.15 in.)	84 x 100 mm 3.3x 3.94 in.
Displacement	1005 cc (61.3 cu in.)	1330 cc (81.2 cu. in.)	1662 cc (101.4 cu in.)
Compression Ratio	23:1	22.5:1	22.5:1
Rated Engine Speed	2700 rpm	2700 rpm	2700 rpm
Low Idle Speed	1000 rpm	1000 rpm	1000 rpm
Maximum Idle Speed- No Load	2940 rpm	2940 rpm	2940 rpm
Firing Order	1-2-3	1-2-3	1-2-3
Cylinder Arrangement	Inline Vertical	Inline Vertical	Inline Vertical
Valve Arrangement	Overhead	Overhead	Overhead
Compression Pressure @ 200 rpm (cylinder speed)	29.4 ± 3.5 bar (427±50 psi)	29.4 ± 3.5 bar (427±50 psi)	29.4 ± 3.5 bar (427±50 psi)

CYLINDER BLOCK SPECIFICATIONS

Tractor Model	MC 22	MC 28	MC 35
Engine Model	S773	J843	N843L
Bore Standard	77.0 mm (3.0315 - 3.0322 in.)	84.0 mm (3.3071 - 3.3078 in.)	84.0 mm (3.3071 - 3.3078 in.)
Maximum	77.52 mm (3.0520 in.)	85.2 mm (3.3543 in.)	85.2 mm (3.3543 in.)
Re-Bore Size ¹ .5 mm (0.020 in.) oversize	72 mm (3.0510 - 3.0520 in.)	84.2 mm (3.3268 - 3.3275 in.)	84.2 mm (3.3268 - 3.3275 in.)
1.0 mm (.040 in.) oversize	N/A	84.7 mm (3.3465 - 3.3472 in.)	84.7 mm (3.3465 - 3.3472 in.)
Head Surface Warp Standard	0.05 mm (0.002 in.)	0.05 mm (0.002 in.)	0.05 mm (0.002 in.)
Maximum	0.12 mm (0.005 in.)	0.12 mm (0.005 in.)	0.12 mm (0.005 in.)

¹ If MC 22 bore exceeds 77.7 mm (3.059 in.), replace the cylinder block. If MC 28 or MC 35 bore exceeds 85.2 mm (3.3543 in.), replace the cylinder block.

This as a preview PDF file from best-manuals.com



Download full PDF manual at best-manuals.com