

# Shop Manual

BULLDOZER

***D51EXi-24***  
***D51PXi-24***

SERIAL NUMBERS    D51EXi-10001    and up  
                                 D51PXi-10001

**KOMATSU**



---

# 00 INDEX AND FOREWORD

---

# INDEX

00 INDEX AND FOREWORD .....	00-1
ABBREVIATION LIST .....	00-20
FOREWORD, SAFETY, BASIC INFORMATION .....	00-26
HOW TO READ THE SHOP MANUAL .....	00-26
SAFETY NOTICE FOR OPERATION .....	00-28
PRECAUTIONS TO PREVENT FIRE .....	00-36
ACTIONS IF FIRE OCCURS .....	00-38
PRECAUTIONS FOR DISPOSING OF WASTE MATERIALS .....	00-39
ACTIONS TAKEN TO MEET EXHAUST GAS REGULATIONS .....	00-40
PRECAUTIONS FOR DEF .....	00-41
STORE AdBlue/DEF .....	00-42
PRECAUTIONS FOR HANDLING HYDRAULIC EQUIPMENT .....	00-43
PRECAUTIONS FOR DISCONNECTION AND CONNECTION OF PIPINGS .....	00-46
PRECAUTIONS FOR HANDLING ELECTRICAL EQUIPMENT .....	00-52
PRECAUTIONS FOR HANDLING FUEL SYSTEM EQUIPMENT .....	00-54
PRECAUTIONS FOR HANDLING INTAKE SYSTEM EQUIPMENT .....	00-55
PRACTICAL USE OF KOMTRAX .....	00-56
DISCONNECT AND CONNECT PUSH-PULL TYPE COUPLER .....	00-57
PRECAUTIONS FOR DISCONNECTION AND CONNECTION OF CONNECTORS .....	00-61
METHOD FOR DISCONNECTING AND CONNECTING DEUTSCH CONNECTOR .....	00-65
METHOD FOR DISCONNECTING AND CONNECTING SLIDE LOCK TYPE CONNECTOR .....	00-66
METHOD FOR DISCONNECTING AND CONNECTING CONNECTOR WITH LOCK TO PULL ..	00-68
METHOD FOR DISCONNECTING AND CONNECTING CONNECTOR WITH LOCK TO PUSH ..	00-69
METHOD FOR DISCONNECTING AND CONNECTING CONNECTOR WITH HOUSING TO ROTATE .	00-71
HOW TO READ ELECTRICAL WIRE CODE .....	00-72
EXPLANATION OF TERMS FOR MAINTENANCE STANDARD .....	00-76
STANDARD TIGHTENING TORQUE TABLE .....	00-79
CONVERSION TABLE .....	00-86
01 SPECIFICATIONS .....	01-1
CONTENTS .....	01-2
ABBREVIATION LIST .....	01-3
SPECIFICATIONS .....	01-9
SPECIFICATION DRAWING .....	01-9
SPECIFICATIONS .....	01-13
WEIGHT TABLE .....	01-24
FUEL, COOLANT, LUBRICANTS (FOR NORTH AMERICA) .....	01-28
FUEL, COOLANT, LUBRICANTS (FOR EUROPEAN UNION) .....	01-30
10 STRUCTURE AND FUNCTION .....	10-1
CONTENTS .....	10-2
ABBREVIATION LIST .....	10-5
UREA SCR SYSTEM .....	10-11
LAYOUT DRAWING OF UREA SCR SYSTEM .....	10-11
UREA SCR SYSTEM DIAGRAM .....	10-13
FUNCTION OF UREA SCR SYSTEM .....	10-14
COMPONENT PARTS OF UREA SCR SYSTEM .....	10-32
BOOT-UP SYSTEM .....	10-41
LAYOUT DRAWING OF BOOT-UP SYSTEM .....	10-41
SYSTEM OPERATING LAMP SYSTEM .....	10-42
BATTERY DISCONNECT SWITCH .....	10-44
ENGINE SYSTEM .....	10-45
LAYOUT DRAWING OF ENGINE SYSTEM .....	10-45
ENGINE CONTROL SYSTEM .....	10-47
AUTOMATIC IDLE STOP SYSTEM .....	10-53
COMPONENT PARTS OF ENGINE SYSTEM .....	10-56
COOLING SYSTEM .....	10-73

LAYOUT DRAWING OF COOLING SYSTEM .....	10-73
COOLING FAN CONTROL SYSTEM.....	10-75
COMPONENT PARTS OF COOLING SYSTEM.....	10-78
CONTROL SYSTEM.....	10-87
LAYOUT DRAWING OF CONTROL SYSTEM .....	10-87
MACHINE MONITOR SYSTEM .....	10-88
KOMTRAX SYSTEM.....	10-89
COMPONENT PARTS OF CONTROL SYSTEM.....	10-90
HYDRAULIC SYSTEM.....	10-122
LAYOUT DRAWING OF HYDRAULIC SYSTEM .....	10-122
CLSS .....	10-123
COMPONENT PARTS OF HYDRAULIC SYSTEM .....	10-126
POWER TRAIN SYSTEM .....	10-158
LAYOUT DRAWING OF HST SYSTEM .....	10-158
OPERATION OF HST SYSTEM.....	10-159
STEERING AND BRAKE CONTROL SYSTEM .....	10-161
HST CONTROL SYSTEM.....	10-163
PARKING BRAKE CONTROL SYSTEM .....	10-174
COMPONENT PARTS OF POWER TRAIN SYSTEM.....	10-177
WORK EQUIPMENT SYSTEM .....	10-213
WORK EQUIPMENT CONTROL .....	10-213
LAYOUT DRAWING OF FRONT WORK EQUIPMENT .....	10-215
LAYOUT OF FIXED MULTI-SHANK RIPPER.....	10-216
COMPONENT PARTS OF WORK EQUIPMENT SYSTEM.....	10-217
ICT SYSTEM .....	10-233
LAYOUT DRAWING OF ICT SYSTEM.....	10-233
ICT CONTROL SYSTEM DIAGRAM.....	10-235
BLADE CONTROL SYSTEM .....	10-237
SMOOTH START SYSTEM .....	10-243
SLIP CONTROL SYSTEM .....	10-245
ASSIST CONTROL SYSTEM .....	10-246
HST SPEED RANGE CONTROL SYSTEM .....	10-248
COMPONENT PARTS OF ICT SYSTEM .....	10-250
UNDERCARRIAGE AND FRAME.....	10-272
MAIN FRAME .....	10-272
SUSPENSION .....	10-273
TRACK FRAME AND IDLER CUSHION .....	10-276
WORK EQUIPMENT.....	10-278
STRUCTURE OF FRONT WORK EQUIPMENT.....	10-278
STRUCTURE OF FIXED MULTI-SHANK RIPPER.....	10-279
CAB AND ITS ATTACHMENTS .....	10-280
ROPS CAB .....	10-280
CAB MOUNT .....	10-282
20 STANDARD VALUE TABLE .....	20-1
CONTENTS .....	20-2
ABBREVIATION LIST .....	20-3
STANDARD VALUE TABLE FOR ENGINE .....	20-9
STANDARD VALUE TABLE FOR ENGINE: D51EXI-24 .....	20-9
STANDARD VALUE TABLE FOR ENGINE: D51PXI-24 .....	20-13
STANDARD VALUE TABLE FOR MACHINE.....	20-17
STANDARD VALUE TABLE FOR MACHINE: D51EXI-24 .....	20-17
STANDARD VALUE TABLE FOR MACHINE: D51PXI-24 .....	20-34
MACHINE POSTURE AND PROCEDURE FOR MEASURING PERFORMANCE .....	20-49
30 TESTING AND ADJUSTING .....	30-1
CONTENTS .....	30-2
ABBREVIATION LIST .....	30-6
RELATED INFORMATION ON TESTING AND ADJUSTING .....	30-12
TOOLS FOR TESTING AND ADJUSTING.....	30-12

SKETCH OF TOOLS FOR TESTING AND ADJUSTING .....	30-19
ENGINE AND COOLING SYSTEM.....	30-23
TEST ENGINE SPEED .....	30-23
TEST BOOST PRESSURE.....	30-25
TEST EXHAUST GAS COLOR.....	30-27
TEST AND ADJUST VALVE CLEARANCE.....	30-29
TEST COMPRESSION PRESSURE.....	30-31
TEST BLOWBY PRESSURE .....	30-36
TEST ENGINE OIL PRESSURE.....	30-38
TEST FUEL PRESSURE .....	30-39
TEST FUEL DISCHARGE, RETURN AND LEAKAGE .....	30-44
BLEED AIR FROM FUEL SYSTEM .....	30-50
TEST FUEL CIRCUIT FOR LEAKAGE .....	30-51
HANDLE CYLINDER CUT-OUT MODE OPERATION.....	30-53
HANDLE NO-INJECTION CRANKING OPERATION.....	30-54
TEST KDOC, SCR AND MUFFLER STACK FOR LOOSENESS AND DAMAGE .....	30-55
TEST INSTALLED CONDITION OF CYLINDER HEADS AND MANIFOLDS.....	30-56
TEST ENGINE PIPING FOR DAMAGE AND LOOSENESS.....	30-57
WRITE ASH IN SOOT ACCUMULATION CORRECTION TO ENGINE CONTROLLER.....	30-58
TEST SCR RELATED FUNCTIONS.....	30-59
CLEAN AdBlue/DEF TANK .....	30-87
CLEAN AdBlue/DEF TANK MOUNTING PORTION .....	30-91
POWER TRAIN.....	30-92
TEST AND ADJUST HST OIL PRESSURE .....	30-92
BLEED AIR FROM HST PUMP .....	30-97
TEST OUTLET PRESSURE OF SOLENOID VALVE .....	30-99
TEST TRAVEL DEVIATION .....	30-103
TEST BRAKE PERFORMANCE SIMPLY .....	30-105
TEST AND ADJUST DECELERATION/BRAKE PEDAL.....	30-106
ADJUST PARKING BRAKE LEVER.....	30-110
MOVE MACHINE WHEN IT CANNOT TRAVEL.....	30-112
UNDERCARRIAGE AND FRAME.....	30-115
CHECK AND ADJUST IDLER CLEARANCE .....	30-115
TESTING SPROCKET WEAR .....	30-117
TEST AND ADJUST TRACK TENSION.....	30-118
HYDRAULIC SYSTEM.....	30-120
RELEASE REMAINING PRESSURE FROM HYDRAULIC SYSTEM.....	30-120
TEST AND ADJUST WORK EQUIPMENT OIL PRESSURES .....	30-121
TEST AND ADJUST OIL PRESSURE OF CONTROL CIRCUIT.....	30-124
TEST OUTLET PRESSURE OF EPC SOLENOID VALVE .....	30-126
BLEED AIR FROM WORK EQUIPMENT AND COOLING FAN PUMP .....	30-128
TEST COOLING FAN SPEED .....	30-129
TEST COOLING FAN CIRCUIT OIL PRESSURE .....	30-130
TEST THE PARTS CAUSING HYDRAULIC DRIFT IN WORK EQUIPMENT.....	30-132
TEST INTERNAL OIL LEAKAGE OF WORK EQUIPMENT CYLINDER .....	30-135
BLEED AIR FROM WORK EQUIPMENT CYLINDERS.....	30-138
WORK EQUIPMENT.....	30-139
ADJUST WORK EQUIPMENT LOCK LEVER.....	30-139
ELECTRICAL SYSTEM .....	30-141
SET AND OPERATE MACHINE MONITOR.....	30-141
METHOD FOR STARTING UP KOMTRAX TERMINAL .....	30-268
ADJUSTMENT WHEN HST CONTROLLER HAS BEEN REPLACED .....	30-273
ADJUSTMENT WHEN ELECTRIC OR HYDRAULIC DEVICE HAS BEEN REPLACED.....	30-279
ADJUST REARVIEW CAMERA ANGLE .....	30-281
HANDLE VOLTAGE CIRCUIT OF ENGINE CONTROLLER.....	30-282
HANDLE BATTERY DISCONNECT SWITCH .....	30-283
TEST DIODES .....	30-284
ICT SYSTEM .....	30-285

SET AND OPERATE CONTROL BOX .....	30-285
CALIBRATE BLADE EDGE POSITION .....	30-288
CALIBRATE IMU SENSOR .....	30-310
RESET CYLINDER STROKE END .....	30-317
METHOD FOR INPUTTING WEAR AMOUNT OF BLADE EDGE AND TRACK SHOE .....	30-320
CHECK BLADE ELEVATION, ADJUST .....	30-321
TEST STROKE SENSOR FOR LIFT CYLINDER .....	30-325
TEST STROKE SENSOR FOR TILT CYLINDER .....	30-327
TEST STROKE SENSOR FOR ANGLE CYLINDER .....	30-329
TEST AND ADJUST RESET SENSOR FOR LIFT CYLINDER .....	30-331
ADJUST WHEN ICT SENSOR CONTROLLER IS REPLACED .....	30-333
METHOD FOR ADJUSTING WHEN ICT RELATED DEVICES ARE REPAIRED OR REPLACED .....	30-336
Pm CLINIC .....	30-339
Pm CLINIC SERVICE .....	30-339
40 TROUBLESHOOTING .....	40-1
CONTENTS .....	40-2
ABBREVIATION LIST .....	40-13
RELATED INFORMATION ON TROUBLESHOOTING .....	40-19
GENERAL TROUBLESHOOTING POINTS .....	40-19
TROUBLESHOOTING POINTS FOR UREA SCR SYSTEM .....	40-20
SEQUENCE OF EVENTS IN TROUBLESHOOTING .....	40-32
CHECKS BEFORE TROUBLESHOOTING .....	40-34
INSPECTION PROCEDURE BEFORE TROUBLESHOOTING .....	40-36
TESTING IN ACCORDANCE WITH TESTING PROCEDURE .....	40-38
PREPARATION FOR TROUBLESHOOTING OF ELECTRICAL SYSTEM .....	40-60
PROCEDURE FOR TROUBLESHOOTING .....	40-67
INFORMATION DESCRIBED IN TROUBLESHOOTING TABLE .....	40-70
TROUBLESHOOTING METHOD FOR OPEN CIRCUIT IN WIRING HARNESS OF PRESSURE SEN- SOR SYSTEM .....	40-72
CONNECTORS LIST AND LAYOUT .....	40-75
CONNECTOR CONTACT IDENTIFICATION .....	40-92
T-BRANCH BOX AND T-BRANCH ADAPTER TABLE .....	40-132
FUSE LOCATION TABLE .....	40-138
PRECAUTIONS FOR REPLACING KDOC .....	40-142
FAILURE CODES TABLE .....	40-143
TROUBLESHOOTING BY FAILURE CODE (DISPLAY OF CODE) .....	40-162
FAILURE CODE [6091NX] .....	40-162
FAILURE CODE [989L00] .....	40-164
FAILURE CODE [989M00] .....	40-165
FAILURE CODE [989N00] .....	40-166
FAILURE CODE [A1U0N3] .....	40-167
FAILURE CODE [A1U0N4] .....	40-169
FAILURE CODE [A900FR] .....	40-171
FAILURE CODE [A900N6] .....	40-172
FAILURE CODE [A900NY] .....	40-173
FAILURE CODE [AA10NX] .....	40-174
FAILURE CODE [AB00KE] .....	40-176
FAILURE CODE [AQ10MB] .....	40-178
FAILURE CODE [AQ10N3] .....	40-180
FAILURE CODE [AS00R2] .....	40-182
FAILURE CODE [AS00R3] .....	40-183
FAILURE CODE [AS00R4] .....	40-184
FAILURE CODE [AS00R5] .....	40-185
FAILURE CODE [AS00R6] .....	40-186
FAILURE CODE [AS00ZK] .....	40-187
FAILURE CODE [AS10KM] .....	40-188
FAILURE CODE [AS10NR] .....	40-189
FAILURE CODE [AS10NT] .....	40-190

FAILURE CODE [B@BAZG]	40-191
FAILURE CODE [B@BCNS]	40-192
FAILURE CODE [B@CRNS]	40-193
FAILURE CODE [B@CRZG]	40-194
FAILURE CODE [CA115]	40-195
FAILURE CODE [CA122]	40-196
FAILURE CODE [CA123]	40-198
FAILURE CODE [CA131]	40-200
FAILURE CODE [CA132]	40-202
FAILURE CODE [CA144]	40-204
FAILURE CODE [CA145]	40-206
FAILURE CODE [CA153]	40-208
FAILURE CODE [CA154]	40-210
FAILURE CODE [CA187]	40-212
FAILURE CODE [CA221]	40-214
FAILURE CODE [CA222]	40-216
FAILURE CODE [CA227]	40-218
FAILURE CODE [CA234]	40-220
FAILURE CODE [CA238]	40-221
FAILURE CODE [CA239]	40-222
FAILURE CODE [CA249]	40-223
FAILURE CODE [CA256]	40-225
FAILURE CODE [CA271]	40-227
FAILURE CODE [CA272]	40-229
FAILURE CODE [CA295]	40-231
FAILURE CODE [CA322]	40-232
FAILURE CODE [CA324]	40-234
FAILURE CODE [CA331]	40-236
FAILURE CODE [CA332]	40-238
FAILURE CODE [CA343]	40-240
FAILURE CODE [CA351]	40-241
FAILURE CODE [CA352]	40-243
FAILURE CODE [CA356]	40-245
FAILURE CODE [CA357]	40-247
FAILURE CODE [CA386]	40-249
FAILURE CODE [CA428]	40-250
FAILURE CODE [CA429]	40-252
FAILURE CODE [CA435]	40-254
FAILURE CODE [CA441]	40-256
FAILURE CODE [CA442]	40-258
FAILURE CODE [CA451]	40-259
FAILURE CODE [CA452]	40-261
FAILURE CODE [CA488]	40-263
FAILURE CODE [CA515]	40-264
FAILURE CODE [CA516]	40-266
FAILURE CODE [CA553]	40-268
FAILURE CODE [CA555]	40-269
FAILURE CODE [CA556]	40-270
FAILURE CODE [CA559]	40-271
FAILURE CODE [CA595]	40-274
FAILURE CODE [CA687]	40-276
FAILURE CODE [CA689]	40-278
FAILURE CODE [CA691]	40-281
FAILURE CODE [CA692]	40-283
FAILURE CODE [CA697]	40-285
FAILURE CODE [CA698]	40-286
FAILURE CODE [CA731]	40-287
FAILURE CODE [CA778]	40-289



FAILURE CODE [CA1117]	40-294
FAILURE CODE [CA1664]	40-296
FAILURE CODE [CA1669]	40-298
FAILURE CODE [CA1673]	40-299
FAILURE CODE [CA1677]	40-300
FAILURE CODE [CA1678]	40-301
FAILURE CODE [CA1682]	40-302
FAILURE CODE [CA1683]	40-304
FAILURE CODE [CA1684]	40-306
FAILURE CODE [CA1686]	40-308
FAILURE CODE [CA1691]	40-309
FAILURE CODE [CA1694]	40-311
FAILURE CODE [CA1695]	40-313
FAILURE CODE [CA1696]	40-314
FAILURE CODE [CA1712]	40-316
FAILURE CODE [CA1713]	40-319
FAILURE CODE [CA1714]	40-321
FAILURE CODE [CA1715]	40-322
FAILURE CODE [CA1776]	40-323
FAILURE CODE [CA1777]	40-326
FAILURE CODE [CA1843]	40-329
FAILURE CODE [CA1844]	40-331
FAILURE CODE [CA1885]	40-334
FAILURE CODE [CA1887]	40-336
FAILURE CODE [CA1896]	40-338
FAILURE CODE [CA1898]	40-339
FAILURE CODE [CA1938]	40-341
FAILURE CODE [CA1942]	40-343
FAILURE CODE [CA1961]	40-344
FAILURE CODE [CA1962]	40-345
FAILURE CODE [CA2185]	40-346
FAILURE CODE [CA2186]	40-348
FAILURE CODE [CA2198]	40-350
FAILURE CODE [CA2272]	40-352
FAILURE CODE [CA2288]	40-354
FAILURE CODE [CA2311]	40-355
FAILURE CODE [CA2349]	40-356
FAILURE CODE [CA2353]	40-358
FAILURE CODE [CA2357]	40-360
FAILURE CODE [CA2373]	40-361
FAILURE CODE [CA2374]	40-363
FAILURE CODE [CA2375]	40-365
FAILURE CODE [CA2376]	40-367
FAILURE CODE [CA2387]	40-370
FAILURE CODE [CA2554]	40-371
FAILURE CODE [CA2634]	40-372
FAILURE CODE [CA2635]	40-374
FAILURE CODE [CA2636]	40-375
FAILURE CODE [CA2637]	40-377
FAILURE CODE [CA2771]	40-379
FAILURE CODE [CA2961]	40-383
FAILURE CODE [CA2973]	40-384
FAILURE CODE [CA2976]	40-385
FAILURE CODE [CA3142]	40-387
FAILURE CODE [CA3143]	40-388
FAILURE CODE [CA3144]	40-389
FAILURE CODE [CA3146]	40-391
FAILURE CODE [CA3147]	40-392

FAILURE CODE [CA3148]	40-393
FAILURE CODE [CA3151]	40-395
FAILURE CODE [CA3165]	40-400
FAILURE CODE [CA3228]	40-402
FAILURE CODE [CA3229]	40-404
FAILURE CODE [CA3231]	40-406
FAILURE CODE [CA3232]	40-408
FAILURE CODE [CA3235]	40-412
FAILURE CODE [CA3239]	40-414
FAILURE CODE [CA3241]	40-417
FAILURE CODE [CA3242]	40-420
FAILURE CODE [CA3251]	40-423
FAILURE CODE [CA3313]	40-425
FAILURE CODE [CA3314]	40-426
FAILURE CODE [CA3315]	40-427
FAILURE CODE [CA3419]	40-429
FAILURE CODE [CA3421]	40-431
FAILURE CODE [CA3497]	40-433
FAILURE CODE [CA3498]	40-434
FAILURE CODE [CA3545]	40-435
FAILURE CODE [CA3547]	40-437
FAILURE CODE [CA3558]	40-438
FAILURE CODE [CA3559]	40-440
FAILURE CODE [CA3562]	40-442
FAILURE CODE [CA3563]	40-444
FAILURE CODE [CA3567]	40-447
FAILURE CODE [CA3568]	40-451
FAILURE CODE [CA3571]	40-455
FAILURE CODE [CA3572]	40-457
FAILURE CODE [CA3574]	40-459
FAILURE CODE [CA3575]	40-461
FAILURE CODE [CA3577]	40-463
FAILURE CODE [CA3578]	40-465
FAILURE CODE [CA3582]	40-467
FAILURE CODE [CA3583]	40-472
FAILURE CODE [CA3596]	40-474
FAILURE CODE [CA3649]	40-477
FAILURE CODE [CA3681]	40-479
FAILURE CODE [CA3682]	40-484
FAILURE CODE [CA3713]	40-489
FAILURE CODE [CA3717]	40-492
FAILURE CODE [CA3718]	40-493
FAILURE CODE [CA3724]	40-494
FAILURE CODE [CA3725]	40-495
FAILURE CODE [CA3741]	40-498
FAILURE CODE [CA3748]	40-499
FAILURE CODE [CA3755]	40-501
FAILURE CODE [CA3866]	40-503
FAILURE CODE [CA3868]	40-506
FAILURE CODE [CA4152]	40-510
FAILURE CODE [CA4155]	40-514
FAILURE CODE [CA4156]	40-517
FAILURE CODE [CA4157]	40-520
FAILURE CODE [CA4159]	40-522
FAILURE CODE [CA4164]	40-523
FAILURE CODE [CA4165]	40-525
FAILURE CODE [CA4166]	40-527
FAILURE CODE [CA4168]	40-528

FAILURE CODE [CA4169]	40-531
FAILURE CODE [CA4171]	40-533
FAILURE CODE [CA4249]	40-536
FAILURE CODE [CA4251]	40-538
FAILURE CODE [CA4261]	40-541
FAILURE CODE [CA4277]	40-544
FAILURE CODE [CA4459]	40-547
FAILURE CODE [CA4461]	40-549
FAILURE CODE [CA4533]	40-552
FAILURE CODE [CA4534]	40-553
FAILURE CODE [CA4731]	40-554
FAILURE CODE [CA4732]	40-555
FAILURE CODE [CA4739]	40-556
FAILURE CODE [CA4768]	40-557
FAILURE CODE [CA4769]	40-559
FAILURE CODE [CA4842]	40-562
FAILURE CODE [CA4952]	40-565
FAILURE CODE [CA5115]	40-567
FAILURE CODE [CA5179]	40-570
FAILURE CODE [CA5181]	40-572
FAILURE CODE [CA5387]	40-574
FAILURE CODE [CA5388]	40-576
FAILURE CODE [CA5389]	40-579
FAILURE CODE [CA5391]	40-581
FAILURE CODE [CA5392]	40-585
FAILURE CODE [CA5393]	40-587
FAILURE CODE [CA5394]	40-590
FAILURE CODE [CA5395]	40-593
FAILURE CODE [CA5396]	40-596
FAILURE CODE [CA5631]	40-597
FAILURE CODE [CA5632]	40-599
FAILURE CODE [CA5938]	40-600
FAILURE CODE [D130KA]	40-602
FAILURE CODE [D130KB]	40-605
FAILURE CODE [D130KY]	40-607
FAILURE CODE [D19JKZ]	40-609
FAILURE CODE [D811MC]	40-612
FAILURE CODE [D862KA]	40-613
FAILURE CODE [D8ALKA]	40-614
FAILURE CODE [D8ALKB]	40-616
FAILURE CODE [D8AQKR]	40-618
FAILURE CODE [DAF0MB]	40-620
FAILURE CODE [DAF0MC]	40-621
FAILURE CODE [DAF8KB]	40-622
FAILURE CODE [DAF9KQ]	40-624
FAILURE CODE [DAFGMC]	40-625
FAILURE CODE [DAFLKA]	40-626
FAILURE CODE [DAFLKB]	40-628
FAILURE CODE [DAFQKR]	40-630
FAILURE CODE [DAJ000]	40-631
FAILURE CODE [DAJ0KQ]	40-632
FAILURE CODE [DAJ0KT]	40-633
FAILURE CODE [DAJ0MC]	40-634
FAILURE CODE [DAJ1KK]	40-635
FAILURE CODE [DAJ2KK]	40-637
FAILURE CODE [DAJ5KK]	40-639
FAILURE CODE [DAJ6KK]	40-642
FAILURE CODE [DAJLKA]	40-644

FAILURE CODE [DAJLKB]	40-646
FAILURE CODE [DAJPMA]	40-648
FAILURE CODE [DAJQKR]	40-649
FAILURE CODE [DAJRKR]	40-650
FAILURE CODE [DB2QKR]	40-651
FAILURE CODE [DB2RKR]	40-656
FAILURE CODE [DBR0KT]	40-661
FAILURE CODE [DBR0MC]	40-662
FAILURE CODE [DBR1KK]	40-663
FAILURE CODE [DBR2KK]	40-666
FAILURE CODE [DBR5KK]	40-669
FAILURE CODE [DBRLKA]	40-671
FAILURE CODE [DBRLKB]	40-673
FAILURE CODE [DBRPMA]	40-675
FAILURE CODE [DBRQKR]	40-676
FAILURE CODE [DBRRKR]	40-678
FAILURE CODE [DBTSKR]	40-679
FAILURE CODE [DBUTKA]	40-682
FAILURE CODE [DD12KA]	40-683
FAILURE CODE [DD12KB]	40-685
FAILURE CODE [DD13KA]	40-687
FAILURE CODE [DD13KB]	40-689
FAILURE CODE [DD14KA]	40-691
FAILURE CODE [DD14KB]	40-693
FAILURE CODE [DDKAKA]	40-695
FAILURE CODE [DDKAKB]	40-697
FAILURE CODE [DDKFL4]	40-699
FAILURE CODE [DDKGL4]	40-701
FAILURE CODE [DDKHKA]	40-703
FAILURE CODE [DDKHKB]	40-705
FAILURE CODE [DDNLKA]	40-707
FAILURE CODE [DDNLKB]	40-709
FAILURE CODE [DDP6KA]	40-711
FAILURE CODE [DDP6KB]	40-714
FAILURE CODE [DDP6MA]	40-716
FAILURE CODE [DDU1FS]	40-718
FAILURE CODE [DDU1KA]	40-720
FAILURE CODE [DDU1KY]	40-723
FAILURE CODE [DFA4KX]	40-725
FAILURE CODE [DFA4KZ]	40-726
FAILURE CODE [DFA4L8]	40-727
FAILURE CODE [DFA5KA]	40-728
FAILURE CODE [DFA5KB]	40-731
FAILURE CODE [DFA6KA]	40-734
FAILURE CODE [DFA6KB]	40-737
FAILURE CODE [DFA7KX]	40-740
FAILURE CODE [DFA7KZ]	40-741
FAILURE CODE [DFA7L8]	40-742
FAILURE CODE [DFA8KA]	40-743
FAILURE CODE [DFA8KB]	40-746
FAILURE CODE [DFA9KA]	40-749
FAILURE CODE [DFA9KB]	40-752
FAILURE CODE [DGS1KA]	40-755
FAILURE CODE [DGS1KX]	40-758
FAILURE CODE [DH21KA]	40-759
FAILURE CODE [DH21KB]	40-761
FAILURE CODE [DHA4KA]	40-763
FAILURE CODE [DHH7KA]	40-765

FAILURE CODE [DHH7KB]	40-768
FAILURE CODE [DHH8KA]	40-770
FAILURE CODE [DHH8KB]	40-773
FAILURE CODE [DHH9KA]	40-775
FAILURE CODE [DHH9KB]	40-778
FAILURE CODE [DHHAKA]	40-780
FAILURE CODE [DHHAKB]	40-783
FAILURE CODE [DK30KA]	40-785
FAILURE CODE [DK30KB]	40-788
FAILURE CODE [DK30KX]	40-790
FAILURE CODE [DK30KZ]	40-791
FAILURE CODE [DK30L8]	40-792
FAILURE CODE [DK31KA]	40-793
FAILURE CODE [DK31KB]	40-796
FAILURE CODE [DK40KA]	40-798
FAILURE CODE [DK40KB]	40-801
FAILURE CODE [DK55KX]	40-803
FAILURE CODE [DK55KZ]	40-804
FAILURE CODE [DK55L8]	40-805
FAILURE CODE [DK56KA]	40-806
FAILURE CODE [DK56KB]	40-809
FAILURE CODE [DK57KA]	40-811
FAILURE CODE [DK57KB]	40-814
FAILURE CODE [DK80KA]	40-816
FAILURE CODE [DKS0L8]	40-818
FAILURE CODE [DKS1KA]	40-819
FAILURE CODE [DKS1KB]	40-821
FAILURE CODE [DKS2KA]	40-822
FAILURE CODE [DKS2KB]	40-824
FAILURE CODE [DKS3KA]	40-825
FAILURE CODE [DKS3KB]	40-827
FAILURE CODE [DKS3MB]	40-828
FAILURE CODE [DKS4L8]	40-829
FAILURE CODE [DKS5KA]	40-830
FAILURE CODE [DKS5KB]	40-832
FAILURE CODE [DKS6KA]	40-833
FAILURE CODE [DKS6KB]	40-835
FAILURE CODE [DKS7MB]	40-836
FAILURE CODE [DKSCL8]	40-837
FAILURE CODE [DKSDKA]	40-838
FAILURE CODE [DKSDKB]	40-840
FAILURE CODE [DKSEKA]	40-841
FAILURE CODE [DKSEKB]	40-843
FAILURE CODE [DKSFKA]	40-844
FAILURE CODE [DKSFKB]	40-846
FAILURE CODE [DKSFMB]	40-847
FAILURE CODE [DLM0KX]	40-849
FAILURE CODE [DLM0MA]	40-850
FAILURE CODE [DLM1KA]	40-851
FAILURE CODE [DLM1KB]	40-853
FAILURE CODE [DLM1MA]	40-855
FAILURE CODE [DLM2KA]	40-856
FAILURE CODE [DLM2KB]	40-858
FAILURE CODE [DLM2MA]	40-860
FAILURE CODE [DLM3KA]	40-861
FAILURE CODE [DLM3KB]	40-863
FAILURE CODE [DLM3MB]	40-865
FAILURE CODE [DN21FS]	40-866

FAILURE CODE [DR21KX] .....	40-868
FAILURE CODE [DR31KX] .....	40-869
FAILURE CODE [DV20KB] .....	40-870
FAILURE CODE [DW4BKA] .....	40-872
FAILURE CODE [DW4BKB] .....	40-874
FAILURE CODE [DW4BKY] .....	40-876
FAILURE CODE [DW7BKA] .....	40-878
FAILURE CODE [DW7BKB] .....	40-880
FAILURE CODE [DW7EKA] .....	40-882
FAILURE CODE [DW7EKB] .....	40-884
FAILURE CODE [DW7EKY] .....	40-886
FAILURE CODE [DWN5KA] .....	40-888
FAILURE CODE [DWN5KB] .....	40-890
FAILURE CODE [DWN5KY] .....	40-892
FAILURE CODE [DXA4KA] .....	40-894
FAILURE CODE [DXA4KB] .....	40-896
FAILURE CODE [DXA4KY] .....	40-898
FAILURE CODE [DXA5KA] .....	40-900
FAILURE CODE [DXA5KB] .....	40-902
FAILURE CODE [DXA5KY] .....	40-904
FAILURE CODE [DXA6KA] .....	40-906
FAILURE CODE [DXA6KB] .....	40-908
FAILURE CODE [DXA6KY] .....	40-910
FAILURE CODE [DXA7KA] .....	40-912
FAILURE CODE [DXA7KB] .....	40-914
FAILURE CODE [DXA7KY] .....	40-916
FAILURE CODE [DXHRKA] .....	40-918
FAILURE CODE [DXHRKB] .....	40-920
FAILURE CODE [DXHRKY] .....	40-922
FAILURE CODE [DXHSKA] .....	40-924
FAILURE CODE [DXHSKB] .....	40-926
FAILURE CODE [DXHSKY] .....	40-928
FAILURE CODE [DXHTKA] .....	40-930
FAILURE CODE [DXHTKB] .....	40-932
FAILURE CODE [DXHTKY] .....	40-934
FAILURE CODE [DXHUKA] .....	40-936
FAILURE CODE [DXHUKB] .....	40-938
FAILURE CODE [DXHUKY] .....	40-940
FAILURE CODE [DXJ4KA] .....	40-942
FAILURE CODE [DXJ4KB] .....	40-944
FAILURE CODE [DXJCKA] .....	40-946
FAILURE CODE [DXJCKB] .....	40-948
FAILURE CODE [DXJCKY] .....	40-950
FAILURE CODE [DXJDKA] .....	40-952
FAILURE CODE [DXJDKB] .....	40-954
FAILURE CODE [DXJDKY] .....	40-956
FAILURE CODE [DXK1KA] .....	40-958
FAILURE CODE [DXK1KB] .....	40-960
FAILURE CODE [DXK1KY] .....	40-962
FAILURE CODE [DXK2KA] .....	40-964
FAILURE CODE [DXK2KB] .....	40-966
FAILURE CODE [DXK2KY] .....	40-968
TROUBLESHOOTING OF ELECTRICAL SYSTEM (E-MODE) .....	40-970
E-1 ENGINE DOES NOT START (ENGINE DOES NOT CRANK) .....	40-970
E-2 MANUAL PREHEATING SYSTEM DOES NOT WORK .....	40-977
E-3 AUTOMATIC PREHEATING SYSTEM DOES NOT WORK .....	40-980
E-4 WHILE PREHEATING IS WORKING, PREHEATING MONITOR DOES NOT LIGHT UP .....	40-982

E-5 WHEN STARTING SWITCH IS TURNED TO ON POSITION, MACHINE MONITOR DISPLAYS NOTHING.....	40-984
E-6 WHEN STARTING SWITCH IS TURNED TO ON POSITION (WITH ENGINE STOPPED), BASIC CHECK MONITOR LIGHTS UP .....	40-988
E-7 AIR CLEANER CLOGGING MONITOR LIGHTS UP IN YELLOW WHILE ENGINE IS RUNNING.....	40-989
E-8 CHARGE LEVEL MONITOR LIGHTS UP IN RED WHILE ENGINE IS RUNNING .....	40-990
E-9 ENGINE COOLANT TEMPERATURE MONITOR LIGHTS UP IN RED WHILE ENGINE IS RUNNING .....	40-991
E-10 ENGINE OIL PRESSURE MONITOR LIGHTS UP IN RED WHILE ENGINE IS RUNNING ..	40-992
E-11 HST CHARGE PRESSURE MONITOR LIGHTS UP IN RED WHILE ENGINE IS RUNNING .....	40-993
E-12 HYDRAULIC OIL TEMPERATURE MONITOR LIGHTS UP IN RED WHILE ENGINE IS RUNNING .....	40-994
E-13 HST OIL FILTER CLOGGING MONITOR LIGHTS UP IN RED WHILE ENGINE IS RUNNING .....	40-995
E-14 ENGINE COOLANT TEMPERATURE GAUGE DOES NOT INDICATE CORRECT TEMPERATURE .....	40-996
E-15 FUEL LEVEL GAUGE DOES NOT INDICATE CORRECT LEVEL .....	40-997
E-16 HYDRAULIC OIL TEMPERATURE GAUGE DOES NOT INDICATE CORRECT TEMPERATURE..	40-1000
E-17 OPERATION MODE DOES NOT CHANGE.....	40-1001
E-18 OPERATING CUSTOMIZE SWITCH DOES NOT DISPLAY CUSTOMIZE SCREEN.....	40-1002
E-19 MODIFYING SETTING ON CUSTOMIZE SCREEN DOES NOT CHANGE SETTING OF MACHINE .....	40-1003
E-20 SERVICE METER IS NOT DISPLAYED, WHILE STARTING SWITCH IS IN OFF POSITION.....	40-1004
E-21 SERVICE MODE CANNOT BE SELECTED .....	40-1005
E-22 WORK EQUIPMENT DOES NOT OPERATE .....	40-1006
E-23 FOOT HEATER DOES NOT OPERATE .....	40-1008
E-24 HORN DOES NOT SOUND.....	40-1014
E-25 HORN DOES NOT STOP SOUNDING.....	40-1016
E-26 BACKUP ALARM DOES NOT SOUND .....	40-1017
E-27 BACKUP ALARM DOES NOT STOP SOUNDING.....	40-1018
E-28 HEADLAMP DOES NOT LIGHT UP .....	40-1019
E-29 REAR LAMP DOES NOT LIGHT UP .....	40-1023
E-30 ALL WIPERS DO NOT OPERATE.....	40-1026
E-31 FRONT WIPER DOES NOT OPERATE .....	40-1028
E-32 REAR WIPER DOES NOT OPERATE.....	40-1030
E-33 LEFT DOOR WIPER DOES NOT OPERATE .....	40-1032
E-34 RIGHT DOOR WIPER DOES NOT OPERATE .....	40-1036
E-35 FRONT WASHER DOES NOT OPERATE.....	40-1040
E-36 REAR WASHER DOES NOT OPERATE .....	40-1042
E-37 LEFT DOOR WASHER DOES NOT OPERATE.....	40-1044
E-38 RIGHT DOOR WASHER DOES NOT OPERATE .....	40-1046
E-39 KOMTRAX SYSTEM DOES NOT OPERATE NORMALLY .....	40-1048
E-40 CONTROL BOX SHUTS DOWN AFTER DISPLAYING THE MESSAGES [GPS receiver not connected !] AND [Slope sensor not connected !] .....	40-1049
E-41 CONTROL BOX DISPLAYS THE MESSAGES [GPS receiver not connected !] AND [Slope sensor not connected !].....	40-1053
E-42 CONTROL BOX DISPLAYS THE MESSAGE [Waiting for radio link...] .....	40-1058
E-43 CONTROL BOX DISPLAYS THE MESSAGE [IMU sensor not connected].....	40-1059
E-44 CONTROL BOX DISPLAYS THE MESSAGE [Waiting for satellites...].....	40-1060
E-45 CONTROL BOX DISPLAYS THE MESSAGE [Komatsu controller not connected!] .....	40-1061
E-46 CONTROL BOX DISPLAYS THE MESSAGE [Cylinder Stroke Reading Abnormal].....	40-1063
E-47 CONTROL BOX DISPLAYS THE MESSAGE [Komatsu CAN Comms Abnormal] .....	40-1064
E-48 CONTROL BOX DISPLAYS THE MESSAGE [Komatsu Machine Trouble] .....	40-1065
E-49 CONTROL BOX DISPLAYS THE MESSAGE [Waiting to initialize....] .....	40-1066

E-50 CONTROL BOX DISPLAYS THE MESSAGE [System Initializing]..... 40-1067

E-51 CONTROL BOX DISPLAYS THE MESSAGE [Initializing.....]..... 40-1068

E-52 CONTROL BOX DISPLAYS THE MESSAGE [Configuring GPS]..... 40-1069

E-53 CONTROL BOX DISPLAYS THE MESSAGE [No GPS Localization...]...... 40-1070

E-54 CONTROL BOX DISPLAYS THE MESSAGE [Low precisions...]...... 40-1071

E-55 CONTROL BOX DISPLAYS THE MESSAGE [Heading Initializing] ..... 40-1072

E-56 CONTROL BOX DISPLAYS [Out of design area...]...... 40-1073

E-57 CONTROL BOX CAN NOT BE TURNED ON ..... 40-1074

E-58 CONTROL BOX DOES NOT DISPLAY INTELLIGENT MACHINE CONTROL SCREEN ... 40-1075

E-59 CONTROL BOX DOES NOT DISPLAY BULLDOZER IMAGE ..... 40-1076

E-60 CONTROL BOX DOES NOT DISPLAY DESIGN SURFACE ..... 40-1077

E-61 CONTROL BOX TOUCH PANEL DOES NOT RESPOND ..... 40-1078

E-62 CONTROL BOX TOUCH PANEL IS INACCURATE..... 40-1079

E-63 CYLINDER STROKE RESET INDICATION DOES NOT GO OUT..... 40-1080

E-64 AUTO IS NOT DISPLAYED WHEN AUTO/MANUAL SWITCH IS PRESSED (AUTO INDICATION GOES OUT) ..... 40-1081

E-65 BLADE AUTOMATIC LOWER CONTROL DOES NOT START WHILE AUTO IS DISPLAYED..... 40-1083

E-66 BLADE AUTOMATIC RAISE CONTROL DOES NOT START WHILE AUTO IS DISPLAYED ..... 40-1084

E-67 BLADE AUTOMATIC CONTROL FUNCTION IS NOT ACTIVATED WHILE AUTO IS DISPLAYED (BLADE AUTOMATIC CONTROL STOPS)..... 40-1085

E-68 WHEN CHECKING AND ADJUSTING THE BLADE ELEVATION, THE VALUE IS DIFFERENT FROM ACTUAL MACHINE ..... 40-1086

E-69 FINISHED SURFACE IS INACCURATE (THE AVERAGE HEIGHT OF FINISHED SURFACE IS LOWER THAN DESIGNED SURFACE OR BLADE DOES NOT TOUCH THE SURFACE)..... 40-1087

E-70 FINISHED SURFACE IS INACCURATE (THE FINISHED SURFACE IS NOT SMOOTH) .. 40-1088

E-71 FINISHED SURFACE IS INACCURATE (WHEN FINISHING SLOPE HORIZONTALLY, STEPS ARE MADE IN EACH DIRECTION)..... 40-1089

E-72 MACHINE CAN NOT ESCAPE FROM SHOES SLIP WHILE BLADE AUTOMATIC CONTROL IS ACTIVATED (SHOES FREQUENTLY SLIPS)..... 40-1091

E-73 MACHINE SPEED DOES NOT INCREASE WHILE BLADE AUTOMATIC CONTROL IS ACTIVATED..... 40-1092

E-74 BLADE TILT ANGLE DOES NOT COINCIDE WITH DESIGN SURFACE ..... 40-1093

E-75 BLADE TILTS BACK WHILE BLADE AUTOMATIC CONTROL IS ACTIVATED..... 40-1095

E-76 WHEN PRESSING CUT/FILL LEVEL SWITCH (RAISE), THE DESIGN SURFACE DOES NOT RISE..... 40-1097

E-77 WHEN PRESSING CUT/FILL LEVEL SWITCH (LOWER), THE DESIGN SURFACE DOES NOT LOWER..... 40-1100

E-78 WHEN STARTING SWITCH IS TURNED TO ON POSITION, REVERSE LEVELING MODE SWITCH LED DOES NOT LIGHT UP OR DOES NOT GO OUT ..... 40-1103

E-79 WHEN REVERSE LEVELING MODE SWITCH IS PRESSED, BUZZER DOES NOT SOUND (DOES NOT SWITCH TO REVERSE LEVELING MODE)..... 40-1105

TROUBLESHOOTING FOR HYDRAULIC AND MECHANICAL SYSTEMS (H MODE) ..... 40-1108

INFORMATION MENTIONED IN TROUBLESHOOTING TABLE (H MODE)..... 40-1108

FAILURE MODE AND CAUSE TABLE..... 40-1109

H-1 NEITHER R.H. NOR L.H. OF TRACKS CAN TRAVEL FORWARD OR REVERSE (NONE OF THE TRAVEL SYSTEMS OPERATE)..... 40-1115

H-2 EITHER R.H. OR L.H. OF TRACK CANNOT TRAVEL BOTH FORWARD AND REVERSE (ONE OF R.H. OR L.H. TRAVEL SYSTEMS CANNOT OPERATE) ..... 40-1117

H-3 EITHER R.H. OR L.H. OF TRACK CANNOT TRAVEL ONE OF FORWARD OR REVERSE (ONLY ONE OF THE TRAVEL SYSTEMS CANNOT OPERATE IN ONE DIRECTION)..... 40-1119

H-4 TRAVEL SPEED OR POWER IS LOW..... 40-1121

H-5 SPEED RANGE DOES NOT CHANGE..... 40-1123

H-6 SHOCK IS LARGE WHEN MACHINE MOVES OFF OR STOPS ..... 40-1124

H-7 MACHINE DEVIATES LARGELY ..... 40-1125

H-8 MACHINE DRIFT ON A SLOPE IS LARGE..... 40-1128

H-9 ENGINE SPEED DROPS LARGELY OR ENGINE STOPS ..... 40-1130



H-10 UNUSUAL NOISE IS HEARD FROM AROUND HST PUMP OR MOTOR .....	40-1132
H-11 HST OIL TEMPERATURE (HYDRAULIC OIL TEMPERATURE) RISES TOO HIGH .....	40-1134
H-12 ALL WORK EQUIPMENT DO NOT OPERATE .....	40-1136
H-13 ALL WORK EQUIPMENTS SPEED OR POWER IS LOW .....	40-1138
H-14 BLADE LIFT SPEED OR POWER IS LOW .....	40-1139
H-15 BLADE TILT SPEED OR POWER IS LOW .....	40-1141
H-16 BLADE ANGLE SPEED OR POWER IS LOW.....	40-1142
H-17 TIME LAG OF BLADE LIFT IS LARGE .....	40-1143
H-18 HYDRAULIC DRIFT OF LIFTED BLADE IS LARGE .....	40-1144
H-19 HYDRAULIC DRIFT OF TILTED BLADE IS LARGE.....	40-1145
H-20 UNUSUAL NOISE IS HEARD FROM AROUND WORK EQUIPMENT AND COOLING FAN PUMP OR CONTROL VALVE .....	40-1146
H-21 FAN SPEED IS ABNORMAL (TOO HIGH OR LOW, OR STATIONARY).....	40-1147
H-22 UNUSUAL NOISE IS HEARD FROM AROUND FAN.....	40-1149
TROUBLESHOOTING OF ENGINE (S-MODE) .....	40-1150
INFORMATION MENTIONED IN TROUBLESHOOTING TABLE (S MODE).....	40-1150
S-1 ENGINE DOES NOT CRANK WHEN STARTING SWITCH IS TURNED TO START POSITION.....	40-1151
S-2 ENGINE CRANKS BUT NO EXHAUST GAS COMES OUT .....	40-1152
S-3 FUEL IS BEING INJECTED BUT ENGINE DOES NOT START (MISFIRING: ENGINE CRANKS BUT DOES NOT START).....	40-1153
S-4 ENGINE STARTABILITY IS POOR.....	40-1155
S-5 ENGINE DOES NOT PICK UP SMOOTHLY .....	40-1157
S-6 ENGINE STOPS DURING OPERATION .....	40-1159
S-7 ENGINE RUNS ROUGH OR IS UNSTABLE .....	40-1161
S-8 ENGINE LACKS POWER.....	40-1162
S-9 EXHAUST SMOKE IS BLACK.....	40-1164
S-10 ENGINE OIL CONSUMPTION IS EXCESSIVE .....	40-1166
S-11 OIL BECOMES CONTAMINATED QUICKLY .....	40-1167
S-12 FUEL CONSUMPTION IS EXCESSIVE .....	40-1168
S-13 OIL IS IN COOLANT (OR COOLANT SPURTS BACK OR COOLANT LEVEL GOES DOWN) .....	40-1169
S-14 OIL PRESSURE DROPS .....	40-1170
S-15 FUEL MIXES INTO ENGINE OIL.....	40-1172
S-16 WATER MIXES INTO ENGINE OIL (MILKY) .....	40-1173
S-17 COOLANT TEMPERATURE RISES TOO HIGH (OVERHEATING).....	40-1174
S-18 UNUSUAL NOISE IS HEARD.....	40-1175
S-19 VIBRATION IS EXCESSIVE .....	40-1176
S-20 AIR CANNOT BE BLED FROM FUEL CIRCUIT.....	40-1177
S-21 ACTIVE REGENERATION IS EXECUTED FREQUENTLY .....	40-1178
S-22 ACTIVE REGENERATION TAKES TIME.....	40-1179
S-23 WHITE SMOKE IS EXHAUSTED DURING ACTIVE REGENERATION.....	40-1180
S-24 AdBlue/DEF CONSUMPTION IS EXCESSIVE .....	40-1181
S-25 THERE IS UNUSUAL SMELL (IRRITATING ODOR).....	40-1183
S-26 FOREIGN MATERIALS ENTER AdBlue/DEF (AdBlue/DEF INCREASES).....	40-1184
50 DISASSEMBLY AND ASSEMBLY.....	50-1
CONTENTS .....	50-2
ABBREVIATION LIST .....	50-7
RELATED INFORMATION ON DISASSEMBLY AND ASSEMBLY .....	50-13
HOW TO READ THIS MANUAL.....	50-13
COATING MATERIALS LIST.....	50-15
SPECIAL TOOLS LIST .....	50-20
SKETCHES OF SPECIAL TOOLS.....	50-42
ENGINE AND COOLING SYSTEM.....	50-55
REMOVE AND INSTALL SUPPLY PUMP ASSEMBLY .....	50-55
REMOVE AND INSTALL INJECTOR ASSEMBLY .....	50-75
REMOVE AND INSTALL CYLINDER HEAD ASSEMBLY .....	50-100
REMOVE AND INSTALL EGR VALVE ASSEMBLY.....	50-143

REMOVE AND INSTALL EGR COOLER ASSEMBLY .....50-150

REMOVE AND INSTALL STARTING MOTOR ASSEMBLY .....50-158

REMOVE AND INSTALL AIR CONDITIONER COMPRESSOR BELT .....50-163

REMOVE AND INSTALL ALTERNATOR BELT .....50-172

REMOVE AND INSTALL AUTOMATIC TENSIONER .....50-177

REMOVE AND INSTALL RADIATOR ASSEMBLY .....50-180

REMOVE AND INSTALL HYDRAULIC OIL COOLER ASSEMBLY .....50-197

REMOVE AND INSTALL AFTERCOOLER ASSEMBLY .....50-208

REMOVE AND INSTALL COOLING FAN DRIVE ASSEMBLY .....50-222

REMOVE AND INSTALL COOLING FAN MOTOR ASSEMBLY .....50-231

REMOVE AND INSTALL ENGINE, HST PUMP ASSEMBLY .....50-237

REMOVE AND INSTALL ENGINE FRONT OIL SEAL .....50-260

REMOVE AND INSTALL ENGINE REAR OIL SEAL .....50-265

REMOVE AND INSTALL ENGINE HOOD ASSEMBLY .....50-269

REMOVE AND INSTALL KDOC ASSEMBLY .....50-276

REMOVE AND INSTALL KDOC AND SCR ASSEMBLY .....50-289

REMOVE AND INSTALL BELLOWS PIPE ASSEMBLY .....50-305

REMOVE AND INSTALL FUEL TANK ASSEMBLY .....50-313

REMOVE AND INSTALL AdBlue/DEF TANK ASSEMBLY .....50-328

REMOVE AND INSTALL AdBlue/DEF TANK SENSOR FLANGE ASSEMBLY .....50-348

REMOVE AND INSTALL AdBlue/DEF TANK SENSOR .....50-354

REMOVE AND INSTALL AdBlue/DEF TANK STRAINER .....50-358

REMOVE AND INSTALL SCR ASSEMBLY .....50-360

REMOVE AND INSTALL KCCV ASSEMBLY .....50-366

REMOVE AND INSTALL AdBlue/DEF MIXING TUBE .....50-370

REMOVE AND INSTALL AdBlue/DEF INJECTOR .....50-378

REMOVE AND INSTALL AdBlue/DEF PUMP .....50-388

REMOVE AND INSTALL AdBlue/DEF HOSE .....50-396

REMOVE AND INSTALL AIR CLEANER ASSEMBLY .....50-438

REMOVE AND INSTALL AIR CONDITIONER COMPRESSOR ASSEMBLY .....50-443

REMOVE AND INSTALL AIR CONDITIONER CONDENSER ASSEMBLY .....50-452

POWER TRAIN .....50-460

    DISASSEMBLE AND ASSEMBLE FINAL DRIVE ASSEMBLY .....50-460

UNDERCARRIAGE AND FRAME .....50-474

    REMOVE AND INSTALL TRACK FRAME ASSEMBLY .....50-474

    REMOVE AND INSTALL IDLER ASSEMBLY .....50-484

    DISASSEMBLE AND ASSEMBLE IDLER ASSEMBLY .....50-489

    REMOVE AND INSTALL RECOIL SPRING ASSEMBLY .....50-496

    DISASSEMBLE AND ASSEMBLE RECOIL SPRING ASSEMBLY .....50-497

    REMOVE AND INSTALL TRACK ROLLER ASSEMBLY .....50-503

    DISASSEMBLE AND ASSEMBLE TRACK ROLLER ASSEMBLY .....50-508

    REMOVE AND INSTALL CARRIER ROLLER ASSEMBLY .....50-513

    DISASSEMBLE AND ASSEMBLE CARRIER ROLLER ASSEMBLY .....50-516

    REMOVE AND INSTALL PIVOT SHAFT ASSEMBLY .....50-520

    SEPARATE AND CONNECT TRACK ASSEMBLY .....50-523

    SEPARATE AND CONNECT PLUS TYPE TRACK ASSEMBLY .....50-528

    DISASSEMBLE AND ASSEMBLE TRACK ASSEMBLY GENERALLY .....50-529

    DISASSEMBLE AND ASSEMBLE PLUS TYPE TRACK ASSEMBLY GENERALLY .....50-547

    DISASSEMBLE AND ASSEMBLE ONE LINK OF TRACK SHOE ASSEMBLY ON THE FIELD ....50-558

    DISASSEMBLE AND ASSEMBLE ONE LINK OF PLUS TYPE TRACK SHOE ASSEMBLY ON THE FIELD .....50-567

    REMOVE AND INSTALL EQUALIZER BAR ASSEMBLY .....50-574

    REMOVE AND INSTALL EQUALIZER BAR SIDE BUSHINGS .....50-579

    REMOVE AND INSTALL SEGMENT TEETH .....50-581

HYDRAULIC SYSTEM .....50-585

    REMOVE AND INSTALL HYDRAULIC TANK ASSEMBLY .....50-585

    REMOVE AND INSTALL CONTROL VALVE ASSEMBLY .....50-601

WORK EQUIPMENT .....50-609

REMOVE AND INSTALL BLADE ASSEMBLY .....	50-609
REMOVE AND INSTALL STROKE SENSING BLADE LIFT CYLINDER ASSEMBLY .....	50-617
DISASSEMBLE AND ASSEMBLE STROKE SENSING BLADE LIFT CYLINDER ASSEMBLY .....	50-621
REMOVE AND INSTALL STROKE SENSING BLADE TILT CYLINDER ASSEMBLY .....	50-634
DISASSEMBLE AND ASSEMBLE STROKE SENSING BLADE TILT CYLINDER ASSEMBLY .....	50-642
REMOVE AND INSTALL STROKE SENSING BLADE ANGLE CYLINDER ASSEMBLY .....	50-651
DISASSEMBLE AND ASSEMBLE STROKE SENSING BLADE ANGLE CYLINDER ASSEMBLY .....	50-657
REMOVE AND INSTALL U-FRAME ASSEMBLY .....	50-667
CAB AND ITS ATTACHMENTS .....	50-674
REMOVE AND INSTALL OPERATOR'S CAB ASSEMBLY .....	50-674
REMOVE AND INSTALL OPERATOR'S CAB GLASS (ADHERED GLASS) .....	50-690
REMOVE AND INSTALL AIR CONDITIONER UNIT ASSEMBLY .....	50-698
REMOVE AND INSTALL RECEIVER DRIER .....	50-711
REMOVE AND INSTALL OPERATOR'S SEAT .....	50-715
REMOVE AND INSTALL SEAT BELT .....	50-717
REMOVE AND INSTALL FOOT HEATER ASSEMBLY .....	50-719
DISASSEMBLE AND ASSEMBLE FOOT HEATER ASSEMBLY .....	50-724
ELECTRICAL SYSTEM .....	50-726
REMOVE AND INSTALL ENGINE CONTROLLER ASSEMBLY .....	50-726
REMOVE AND INSTALL HST CONTROLLER ASSEMBLY .....	50-733
REMOVE AND INSTALL MACHINE MONITOR ASSEMBLY .....	50-735
REMOVE AND INSTALL MASS AIR FLOW AND TEMPERATURE SENSOR .....	50-738
REMOVE AND INSTALL KCCV CRANKCASE PRESSURE SENSOR .....	50-742
REMOVE AND INSTALL ICT SENSOR CONTROLLER ASSEMBLY .....	50-746
REMOVE AND INSTALL CONTROL BOX .....	50-748
REMOVE AND INSTALL GNSS RECEIVER .....	50-750
REMOVE AND INSTALL GNSS ANTENNA .....	50-752
REMOVE AND INSTALL IMU SENSOR .....	50-758
60 MAINTENANCE STANDARD .....	60-1
CONTENTS .....	60-2
ABBREVIATION LIST .....	60-3
ENGINE AND COOLING SYSTEM .....	60-9
MAINTENANCE STANDARD OF ENGINE MOUNT .....	60-9
MAINTENANCE STANDARD OF DAMPER .....	60-10
MAINTENANCE STANDARD OF COOLING SYSTEM .....	60-11
MAINTENANCE STANDARD OF COOLING FAN MOTOR .....	60-13
MAINTENANCE STANDARD OF HYDRAULIC OIL COOLER BYPASS AND HST CHARGE SAFETY VALVE .....	60-15
POWER TRAIN .....	60-16
MAINTENANCE STANDARD OF HST PUMP .....	60-16
MAINTENANCE STANDARD OF HST CHARGE PUMP .....	60-20
MAINTENANCE STANDARD OF HST MOTOR .....	60-22
MAINTENANCE STANDARD OF FINAL DRIVE .....	60-24
MAINTENANCE STANDARD OF SPROCKET FOR PLUS TYPE TRACK SHOE .....	60-26
MAINTENANCE STANDARD OF SPROCKET TOOTH PROFILE FULL-SCALE DRAWING FOR PLUS TYPE TRACK SHOE .....	60-27
UNDERCARRIAGE AND FRAME .....	60-28
MAINTENANCE STANDARD OF SUSPENSION .....	60-28
MAINTENANCE STANDARD OF TRACK FRAME AND IDLER CUSHION .....	60-31
MAINTENANCE STANDARD OF IDLER .....	60-34
MAINTENANCE STANDARD OF TRACK ROLLER FOR PLUS TYPE TRACK SHOES (SINGLE FLANGE TYPE) .....	60-36
MAINTENANCE STANDARD OF TRACK ROLLER FOR PLUS TYPE TRACK SHOES (DOUBLE FLANGE TYPE) .....	60-37
MAINTENANCE STANDARD OF CARRIER ROLLER FOR PLUS TYPE TRACK SHOE .....	60-39
MAINTENANCE STANDARD OF PLUS TYPE TRACK SHOE .....	60-40
MAINTENANCE STANDARD OF SINGLE SHOE .....	60-42
HYDRAULIC SYSTEM .....	60-43

MAINTENANCE STANDARD OF HYDRAULIC TANK .....	60-43
MAINTENANCE STANDARD OF WORK EQUIPMENT AND COOLING FAN PUMP .....	60-44
MAINTENANCE STANDARD OF CONTROL VALVE .....	60-47
MAINTENANCE STANDARD OF RIPPER PPC VALVE .....	60-53
MAINTENANCE STANDARD OF 5-PORT VALVE OF EPC AND SOLENOID .....	60-55
MAINTENANCE STANDARD OF QUICK DROP VALVE .....	60-57
WORK EQUIPMENT .....	60-59
MAINTENANCE STANDARD OF FRONT WORK EQUIPMENT .....	60-59
MAINTENANCE STANDARD OF CUTTING EDGE AND END BIT .....	60-62
MAINTENANCE STANDARD OF STROKE SENSING BLADE LIFT CYLINDER .....	60-63
MAINTENANCE STANDARD OF STROKE SENSING BLADE TILT CYLINDER .....	60-64
MAINTENANCE STANDARD OF STROKE SENSING BLADE ANGLE CYLINDER .....	60-65
MAINTENANCE STANDARD OF STROKE AND RESET SENSOR FOR BLADE LIFT CYLINDER .....	60-66
MAINTENANCE STANDARD OF STROKE SENSOR FOR BLADE TILT CYLINDER .....	60-67
MAINTENANCE STANDARD OF STROKE SENSOR FOR BLADE ANGLE CYLINDER .....	60-68
MAINTENANCE STANDARD OF FIXED MULTI-SHANK RIPPER .....	60-69
MAINTENANCE STANDARD OF RIPPER LIFT CYLINDER .....	60-71
CAB AND ITS ATTACHMENTS .....	60-72
MAINTENANCE STANDARD OF CAB MOUNT .....	60-72
ELECTRICAL SYSTEM .....	60-74
MAINTENANCE STANDARD OF ELECTRIC STEERING CONTROL LEVER .....	60-74
80 APPENDIX .....	80-1
CONTENTS .....	80-2
ABBREVIATION LIST .....	80-3
AIR CONDITIONER SYSTEM .....	80-9
PRECAUTIONS FOR REFRIGERANT .....	80-9
AIR CONDITIONER COMPONENT .....	80-10
SPECIFICATIONS OF AIR CONDITIONER .....	80-13
CONFIGURATION AND FUNCTION OF REFRIGERATION CYCLE .....	80-14
OUTLINE OF REFRIGERATION CYCLE .....	80-15
COMPONENT PARTS OF AIR CONDITIONER SYSTEM .....	80-17
AIR CONDITIONER UNIT .....	80-17
COMPONENT PARTS OF AIR CONDITIONER UNIT .....	80-19
COMPRESSOR .....	80-22
CONDENSER .....	80-23
RECEIVER DRIER .....	80-25
EXPLANATION OF PROCEDURE FOR TESTING AND TROUBLESHOOTING OF AIR CONDITIONER .....	80-27
CIRCUIT DIAGRAM OF AIR CONDITIONER .....	80-30
AIR CONDITIONER SYSTEM DIAGRAM .....	80-31
CONTROL FUNCTION OF AIR CONDITIONER .....	80-32
INSTALLATION LOCATIONS OF AIR CONDITIONER PARTS AND ARRANGEMENT OF CONNECTORS ..	80-33
TEST RELAYS .....	80-37
METHOD FOR TESTING RELAYS .....	80-37
AIR CONDITIONER TROUBLESHOOTING CHART 1 .....	80-39
AIR CONDITIONER TROUBLESHOOTING CHART 2 .....	80-40
INFORMATION DESCRIBED IN TROUBLESHOOTING TABLE .....	80-43
A-1 TROUBLESHOOTING FOR CONDENSER FAN .....	80-45
A-2 TROUBLESHOOTING FOR BLOWER MOTOR SYSTEM (NO AIR COMES OUT OR AIR FLOW IS	
ABNORMAL) .....	80-48
A-3 TROUBLESHOOTING FOR TEMPERATURE CONTROL FUNCTION .....	80-51
TROUBLESHOOTING USING GAUGE PRESSURE .....	80-55
CONNECTION OF SERVICE TOOL .....	80-57
METHOD FOR CONNECTING SERVICE TOOL .....	80-58
PRECAUTIONS FOR DISCONNECTING AND CONNECTING HOSES AND TUBES IN AIR CONDITION-	
ER PIPINGS .....	80-59

HANDLE COMPRESSOR OIL .....	80-61
90 CIRCUIT DIAGRAMS .....	90-1
CONTENTS .....	90-2
ABBREVIATION LIST .....	90-3
HYDRAULIC CIRCUIT DIAGRAM .....	90-9
SYMBOLS USED IN HYDRAULIC CIRCUIT DIAGRAM .....	90-9
HYDRAULIC CIRCUIT DIAGRAM .....	90-13
ELECTRICAL CIRCUIT DIAGRAM .....	90-15
SYMBOLS USED IN ELECTRICAL CIRCUIT DIAGRAM .....	90-15
ELECTRICAL CIRCUIT DIAGRAM (1/14) .....	90-19
ELECTRICAL CIRCUIT DIAGRAM (2/14) .....	90-21
ELECTRICAL CIRCUIT DIAGRAM (3/14) .....	90-23
ELECTRICAL CIRCUIT DIAGRAM (4/14) .....	90-25
ELECTRICAL CIRCUIT DIAGRAM (5/14) .....	90-27
ELECTRICAL CIRCUIT DIAGRAM (6/14) .....	90-29
ELECTRICAL CIRCUIT DIAGRAM (7/14) .....	90-31
ELECTRICAL CIRCUIT DIAGRAM (8/14) .....	90-33
ELECTRICAL CIRCUIT DIAGRAM (9/14) .....	90-35
ELECTRICAL CIRCUIT DIAGRAM (10/14) .....	90-37
ELECTRICAL CIRCUIT DIAGRAM (11/14) .....	90-39
ELECTRICAL CIRCUIT DIAGRAM (12/14) .....	90-41
ELECTRICAL CIRCUIT DIAGRAM (13/14) .....	90-43
ELECTRICAL CIRCUIT DIAGRAM (14/14) .....	90-45
INDEX .....	1

## ABBREVIATION LIST

- This list of abbreviations includes the abbreviations used in the text of the shop manual for parts, components, and functions whose meaning is not immediately clear. The spelling is given in full with an outline of the meaning.
- Abbreviations that are used in general society may not be included.
- Special abbreviations which appear infrequently are noted in the text.
- This list of abbreviations consists of two parts. The first part is a list of the abbreviations used in the text of the manual, and the second part is a list of the abbreviations used in the circuit diagrams.

### List of abbreviations used in the text

Abbreviation	Actual word spelled out	Purpose of use (major applicable machine (*1), or component/system)	Explanation
ABS	Anti-skid Brake System	Travel and brake (HD, HM)	When the tires skid (wheels stop rotating), the brakes are released, and when the wheels start to rotate, the brakes are applied again.
AISS	Automatic Idling Setting System	Engine	This function automatically sets the idle speed.
AJSS	Advanced Joystick Steering System	Steering (WA)	A lever is used to perform the steering operations instead of a steering wheel. Moreover, it shifts gear and changes direction (FORWARD or REVERSE).
ARAC	Automatic Retarder Accelerator Control	Travel and brake (HD, HM)	When the accelerator pedal is released while the machine is traveling downhill, this function automatically applies the retarder with a constant braking force.
ARSC	Automatic Retarder Speed Control	Travel and brake (HD, HM)	When the accelerator pedal is released while the machine is traveling downhill, this function automatically applies the retarder to ensure that the machine speed does not accelerate above the speed set by the operator.
ASR	Automatic Spin Regulator	Travel and brake (HD, HM)	When the tires spin on soft ground surfaces, this function automatically uses the optimum braking force to drive both wheels.
ATT	Attachment	Work equipment	A device that can be fixed onto the standard machine in order to enable it to do different jobs.
BCV	Brake cooling oil control valve	Brake (HD)	When the retarder is not being used, this valve bypasses part of the brake cooling oil to reduce the load on the hydraulic pump.
CAN	Controller Area Network	Communication and electronic control	One of communication standards that is used in the network on the machine.
CDR	Crankcase Depression Regulator	Engine	A regulator valve which is installed to KCCV ventilator. It is written as CDR valve and it is not used independently.
CLSS	Closed-center Load Sensing System	Hydraulic system	This system can simultaneously actuate multiple actuators regardless of the load (provides better combined operation than OLSS).
CRI	Common Rail Injection	Engine	Engine controller electronically controls supply pump, common rail, and injector. This function maintains optimum fuel injection amount and fuel injection timing.

Abbreviation	Actual word spelled out	Purpose of use (major applicable machine (*1), or component/system)	Explanation
ECM	Electronic Control Module	Electronic control system	Electronic control device uses the signals from the sensors on the machine. These signals indicate the optimum actuation to the actuators. (Same as ECU)
ECMV	Electronic Control Modulation Valve	Transmission (D, HD, WA, etc)	Proportional electromagnetic valve that gradually increases oil pressure to engage clutch and reduces transmission shock.
ECSS	Electronically Controlled Suspension System	Travel (WA)	This system ensures smooth high-speed travel by absorbing vibration of machine during travel with hydraulic spring effect of accumulator.
ECU	Electronic Control Unit	Electronic control system	Electronic control device uses the signals from the sensors on the machine. These signals indicate the optimum actuation to the actuators. (Same as ECM)
EGR	Exhaust Gas Recirculation	Engine	This function recirculates part of exhaust gas to combustion chamber in order to reduce combustion temperature, controls emission of NOx.
EMMS	Equipment Management Monitoring System	Machine monitor	This system allows data (filter, oil replacement interval, malfunctions on machine, failure code, and failure history) from each sensor on the machine to be checked on the monitor.
EPC	Electromagnetic Proportional Control	Hydraulic system	This mechanism allows actuators to be operated in proportion to the current supplied.
FOPS	Falling Object Protective Structure	Cab and canopy	This structure protects the operator's head from falling objects.  This performance is standardized as ISO 3449.
F-N-R	Forward-Neutral-Reverse	Operation	Forward - Neutral - Reverse
GPS	Global Positioning System	Communication (KOMTRAX, KOMTRAX Plus)	Global Positioning System: This system uses satellites to determine the current location on the earth.
GNSS	Global Navigation Satellite System	Communication (KOMTRAX, KOMTRAX Plus)	Global Navigation Satellite System: This system uses satellites such as GPS, GALILEO, etc. to determine the current location on the earth.
HSS	Hydrostatic Steering System	Steering (D)	This function uses a combination of hydraulic motor and bevel shaft to control difference in travel speed of right and left tracks. Accordingly machine can turn without using steering clutch.
HST	Hydro Static Transmission	Transmission (D, WA)	This function uses a combination of hydraulic pump and hydraulic motor for stepless shifting of the speed range without using gears.
ICT	Information and Communication Technology	Communication and electronic control	A general term for the engineering and its socially applied technology of information processing and communication.
IMA	Inlet Metering Actuator	Engine	This valve is installed at inlet port of pump, and it adjusts fuel intake amount in order to control fuel discharged volume of supply pump. (Same as IMV)

Abbreviation	Actual word spelled out	Purpose of use (major applicable machine (*1), or component/system)	Explanation
IMU	Inertial Measurement Unit	Engine	This is a device to detect the angle (or angular velocity) and acceleration of the 3 axes that control motions.
IMV	Inlet Metering Valve	Engine	This valve is installed at inlet port of pump, and it adjusts fuel intake amount in order to control fuel discharged volume of supply pump. (Same as IMA)
KCCV	Komatsu Closed Crankcase Ventilation	Engine	This mechanism separates oil in blowby gas and returns it to the intake side to combust it there. It primarily consists of filters.
KCSF	Komatsu Catalyzed Soot Filter	Engine	This filter captures soot in exhaust gas. It is built in to KDPF.
KDOC	Komatsu Diesel Oxidation Catalyst	Engine	The catalyst is used for purifying exhaust gas. It is built in to KDPF or assembled with the muffler.
KDPF	Komatsu Diesel Particulate Filter	Engine	This component is used to purify the exhaust gas. KDOC (catalyst) and KCSF (filter to capture soot) are built-in it. It is installed in place of the conventional muffler.
KTCS	Komatsu Traction Control System	Travel and brake (HM)	This function recovers the drive force of the wheels by braking automatically with the optimum force and at the same time activates the inter-axle differential lock when the wheels idle while the machine travels on the soft ground road.
LCD	Liquid Crystal Display	Machine monitor	Image display equipment such as a monitor which assembles in the liquid crystal element.
LED	Light Emitting Diode	Electronic parts	It refers to semiconductor element that emits light when the voltage is applied in forward direction.
LIN	Local Interconnect Network	Communication and electronic control	One of communication standards that is used in the network on the machine.
LS	Load Sensing	Hydraulic system	Function that detects differential pressure of pump and controls discharged volume corresponding to load.
LVDS	Low Voltage Differential Signaling	Communication and electronic control	One of communication standards that is used in the network on the machine.
MAF	Mass Air Flow	Engine	This indicates engine intake air flow. It is not used independently but it is used as combined with sensor. Mass air flow sensor can be called as MAF sensor.
MMS	Multimedia Messaging Service	Communication	Service that allows transmission and reception of short messages consisting of characters or voice or images between cell phones.
NC	Normally Closed	Electrical system, Hydraulic system	Characteristics of electrical or hydraulic circuits. Circuit is normally closed if it is not actuated, and it opens when it is actuated.



Abbreviation	Actual word spelled out	Purpose of use (major applicable machine (*1), or component/system)	Explanation
NO	Normally Open	Electrical system, Hydraulic system	Characteristics of electrical or hydraulic circuits. Circuit is normally open if it is not actuated, and it closes when it is actuated.
OLSS	Open-center Load Sensing System	Hydraulic system	Hydraulic system that can operate multiple actuators at the same time, regardless of the load.
PC	Pressure Compensation	Hydraulic system	A function used to correct oil pressure.
PCCS	Palm command control system	Steering (D)	System in which a controller instantly analyses data from each lever, pedal, and dial, and performs optimum electronic control of the engine and transmission.
PCV	Pre-stroke Control Valve	Engine	This valve is installed at inlet port of pump and it adjusts fuel intake amount in order to control fuel discharged volume of supply pump.
PPC	Proportional Pressure Control	Hydraulic system	This system is used for controlling proportional pressure. It moves actuators in proportion to the oil pressure.
PPM	Piston Pump and Motor	Hydraulic system (D, PC, etc)	Piston type hydraulic pump and motor.
PTO	Power Take Off	Power train system	Power take-off mechanism.
PTP	Power Tilt and power Pitch dozer	Work equipment (D)	This function performs hydraulic control of the tilt and pitch of the bulldozer blade.
ROPS	Roll-Over Protective Structure	Cab and canopy	Structure protects the operator who wear the seatbelt so that he will not be crushed by a machine when it is tipped. (Operator Protective structure when tipping)  Structure which is standardized as ISO 3471 or ISO 12117-2.
SCR	Selective Catalytic Reduction	Urea SCR system	It is exhaust gas purifier using urea water converts nitrogen oxides (NO <sub>x</sub> ) to harmless nitrogen and water by oxidation-reduction reaction. It may also be mentioned as exhaust gas purification catalyst or part of the name of related devices.
SI	Le Systeme International d' Unites (International unit system)	Unit	Abbreviation for "Le Systeme International d' Unites". It is the universal unit system and "a single unit for a single quantity" is the basic principle applied.
SOL	Solenoid	Electrical system	It refers to an actuator consisting of a solenoid and an iron core that is moved by the magnetic force when the solenoid is energized.
TOPS	Tip-Over Protective Structure	Cab and canopy	Structure protects the operator who wear the seatbelt so that he will not be crushed by a machine when it is overtuned.(Hydraulic excavator tip-over protective structure)  Structure which is standardized as ISO 12117.
TWV	2-Way Valve	Hydraulic system	Solenoid valve that switches over direction of flow.

Abbreviation	Actual word spelled out	Purpose of use (major applicable machine (*1), or component/system)	Explanation
VGT	Variable Geometry Turbocharger	Engine	The turbocharger on which the cross-section area of the exhaust passage is made variable.
VHPC	Variable HorsePower Control	Engine control system	Finely controls the maximum output of the machine. High work efficiency and low fuel consumption rate are both achieved.

\*1: Code for applicable machine model

D: Bulldozer

HD: Dump truck

HM: Articulate dump truck

PC: Hydraulic excavator

WA: Wheel loader

### List of abbreviations used in the circuit diagrams

Abbreviation	Actual word spelled out
A/C	Air Conditioner
A/D	Analogue-to-Digital
A/M	Air Mix Damper
ACC	Accessory
ADD	Additional
AUX	Auxiliary
BR	Battery Relay
CW	Clockwise
CCW	Counter Clockwise
ECU	Electronic Control Unit
ECM	Electronic Control Module
ENG	Engine
EXGND	External Ground
F.G.	Frame Ground
GND	Ground
IMA	Inlet Metering Actuator
NC	No Connection
S/T	Steering
STRG	
SIG	Signal
SOL	Solenoid
STD	Standard
OPT	Option
OP	
PRESS	Pressure

---

Abbreviation	Actual word spelled out
SPEC	Specification
SW	Switch
TEMP	Temperature
T/C	Torque Converter
T/M	Transmission

# FOREWORD, SAFETY, BASIC INFORMATION

## HOW TO READ THE SHOP MANUAL

### REMARK

- Some of the attachments and options described in this shop manual may not be available in some areas. If they are required, consult your Komatsu distributor.
- The materials and specifications are subject to change without notice.
- Shop Manuals are available for "machine part" and "engine part". For the engine unit, see the shop manual for the machine which has the same engine model.
- Actual machine may differ from the images which are contained in this manual. A typical model is shown in the illustrations of this shop manual.

## Composition of the shop manual

This shop manual contains technical information necessary to perform services in workshops. It is divided into the following chapters for the ease of use.

### 00 INDEX AND FOREWORD

This section describes the index, foreword, safety, and basic information.

### 01 SPECIFICATIONS

This section describes the specifications of the machine.

### 10 STRUCTURE AND FUNCTION

This section describes the structure and operation of each component with respect to each system. "STRUCTURE AND FUNCTION" is helpful in not only understanding the structure of each component but performing troubleshooting.

### 20 STANDARD VALUE TABLE

This section describes the standard values for new machine and failure criteria for testing and adjusting, and troubleshooting. Use the standard values table to check the standard values for testing and adjusting, and judge troubles in troubleshooting.

### 30 TESTING AND ADJUSTING

This section describes the measuring tools and measuring methods for testing and adjusting as well as the adjusting method of each part. The standard values and repair limit for TESTING AND ADJUSTING are described in "STANDARD VALUE TABLE".

### 40 TROUBLESHOOTING

This section describes troubleshooting of failure part and its remedy method on the occurrence of the failure. Descriptions of troubleshooting are sorted by failure mode.

### 50 DISASSEMBLY AND ASSEMBLY

This section describes the special tools, work procedures, and safety precautions necessary for removal, installation, disassembly, and assembly of the components and parts. In addition, tightening torques, quantity, and weight of the coating materials, lubricants, and coolant necessary to these works are shown.

### 60 MAINTENANCE STANDARD

This section describes the maintenance standard value of each component. The maintenance standard shows the criteria and remedies for disassembly and assembly.

### 80 THE OTHER INFORMATION









This section describes the structure and function, testing and adjusting, and troubleshooting for all of the other components or equipment which cannot be separately classified in the appendix.

### 90 Circuit diagrams

This section describes hydraulic circuit diagrams and electrical circuit diagrams.

## Symbols

Important safety and quality portions are marked with the following symbols so that shop manual is used effectively.

Symbol	Item	Remark
	Danger	This signal indicates an extremely hazardous situation which will result in death or serious injury if it is not avoided.
	Warning	This signal indicates a potentially hazardous situation which will result in death or serious injury if it is not avoided.
	Caution	This signal indicates a potentially hazardous situation which will result in injury or property damage around the machine if it is not avoided.
	Weight	This signal indicates the weight of parts and components, and items which requires great attention to a selection of wires and working posture for slinging work.
	Tightening torque	This signal indicates the tightening torque for portions which requires special care in assembling work.
	Coat	This signal indicates a place to be coated with adhesive, grease, etc. in assembling work.
	Oil and coolant	This signal indicates a place to supply oil, coolant, etc. and the quantity.
	Draining	This signal indicates a place to drain oil, coolant, etc. and the quantity.
	Safety	This symbol indicates the works which require special caution for the machine safety when assembling.

## Signal word



Signal word for notice and remark describes the following.

Symbol	Item	Remark
NOTICE	Notice	If the precaution of this signal word is not observed, the machine damage or shortening of service life may occur.
REMARK	Remark	This signal word contains useful information to know.

## Unit

International System of Units (SI) is used in this manual. For reference, units that have been used in the past are given in { }.

## SAFETY NOTICE FOR OPERATION

- Appropriate servicing and repair are extremely important to ensure safe operation of the machine. The shop manuals describe the effective and safe servicing and repair methods recommended by Komatsu. Some of the servicing and repair methods require the use of special tools designed by Komatsu for special purposes.
- The symbol mark  is indicated for such matters that require special precautions. The work indicated with this warning mark  should be performed according to the instructions with special attention. Should a hazardous situation occurs or be anticipated during such work, be sure to keep safe first and take every necessary measures.

### Safety matters

- Well organized work place
- Correct work clothes
- Observance of work standard
- Enforcement of hand signals
- Prohibition against unlicensed persons operating and handling the machine
- Safety check before starting work
- Wear of dust glasses (for cleaning or grinding work)
- Wear of welding goggles and protectors (for welding work)
- Being in good physical condition, and good preparation
- Always be alert and careful.

### General precautions

 **If the machine is handled incorrectly, it is dangerous. Read and understand what is described in the operation and maintenance manual before operation. Read and understand what is described in this manual before operation.**

- Read and understand the meaning of all the safety labels stuck to the machine before performing any greasing or repairs. For the locations of the safety labels and detailed explanation of precautions, see Operation and Maintenance Manual.
- Tools and removed parts in the workshop should be well organized. Always keep the tools and parts in their correct places. Always keep the work area clean and make sure that there is no dust, dirt, oil, or water on the floor. Smoke only in the designated areas. Never smoke while working.
- Keep all tools in good condition, learn the correct way to use them, and use the proper ones. Check the tools, machine, forklift truck, service car, etc. thoroughly before starting the work.
- Always wear safety shoes and helmet when performing any operation. Do not wear loose clothes, or clothes with buttons missing.

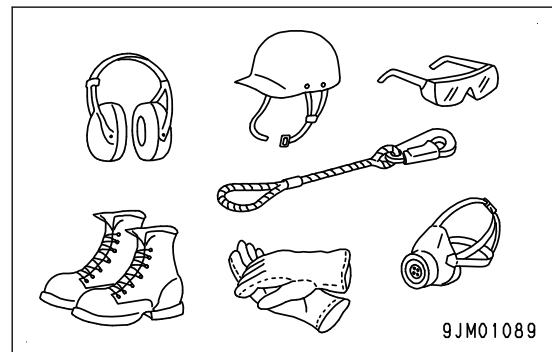

- Always wear the protective eyeglasses when hitting parts with a hammer.
- Always wear the protective eyeglasses when grinding parts with a grinder, etc.
- When performing any operation with multiple workers, always agree on the operating procedure before starting. Be clear in verbal communication, and observe hand signals. Hang "UNDER REPAIR" warning tag in the operator's compartment Before starting work.
- Work and operation which require license or qualification should be performed by qualified workers.
- Welding repairs should be performed by trained and experienced welders. When performing welding work, always wear welding gloves, apron, welding goggles, cap and other clothes suited for welding work.
- Warm up before starting the work with exercise which increases alertness and the range of motion in order to prevent injury.
- Avoid prolonged work, and take a rest at times to keep up a good condition. Take a rest at designated safe area.

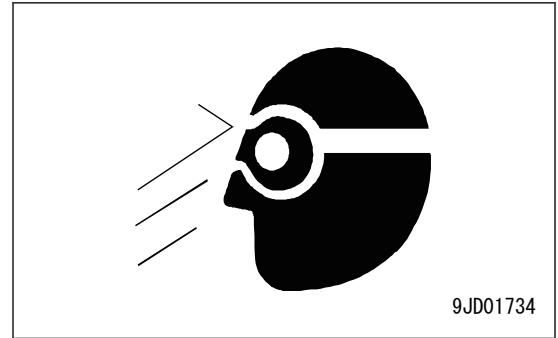

### Precautions for preparatory work

- Place the machine on a firm and level ground, and apply the parking brake and chock the wheels or tracks to prevent the machine from moving before adding oil or making any repairs.
- Lower the work equipment (blade, ripper, bucket, etc.) to the ground before starting work. If this is not possible, insert the lock pin or use blocks to prevent the work equipment from falling. In addition, be sure to lock all the control levers and hang "UNDER REPAIR" warning tag on them.
- When performing the disassembling or assembling work, support the machine securely with blocks, jacks, or stands before starting the work.
- Remove all mud and oil from the steps or other places for going up and down on the machine. Always use the handrails, ladders or steps when for going up and down on the machine. Never jump on or off the machine. When the scaffold is not provided, use steps or stepladder to secure your footing. Do not use handrails, ladders, or steps if they are damaged or deformed. Repair it or replace it immediately.

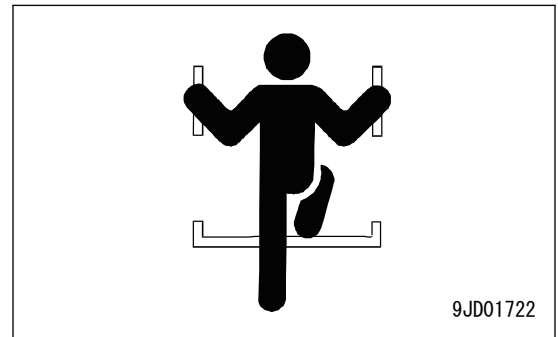

### Precautions during work

- For the machine with the battery disconnect switch, check before starting the work that the system operating lamp is not lit. Then, turn the battery disconnect switch to OFF (○) position.

#### REMARK

Remove the key after it is turned to OFF (○) position if the battery disconnect switch is a switch key type. For the machine without the battery disconnect switch, turn the starting switch to OFF position, wait for two minutes or more before starting the work. Disconnect the battery cable by starting from the negative (-) terminal first.

- For the machine with the quick release battery terminal (-), check before starting the work that the system operating lamp is not lit. Then, disconnect the quick release battery terminal (-).

#### REMARK

For the machine without the system operating lamp, turn the starting switch to OFF position, wait for two minutes or more before starting the work. Disconnect the quick release battery terminal (-).

- Release the remaining pressure from the circuit before starting the work of disconnecting and removing of oil, fuel, water, or air from the circuit. When removing the cap of oil filter, drain plug, or oil pressure plug, it should be done slowly otherwise the oil spills.
- When removing or installing the checking plug or the piping in the fuel circuit, wait 30 seconds or longer after the engine is shut down and start the work after the remaining pressure is released from the fuel circuit.
- The coolant and oil in the circuits are hot when the engine is shut down. Be careful not to get scalded. Wait for the oil and coolant to cool before performing any work on the oil or coolant circuits.

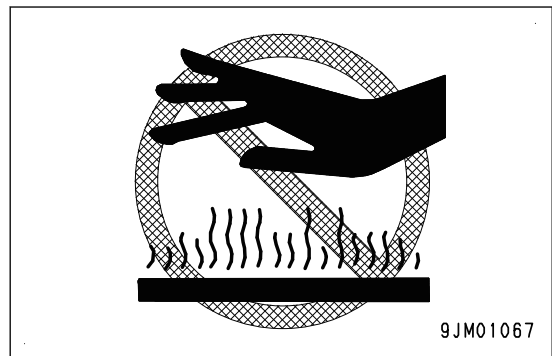
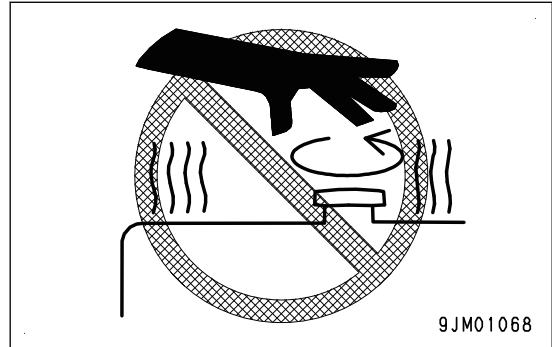

- Before starting work, shut down the engine. When working on or around a rotating part, in particular, shut down the engine. When checking the machine without shutting down the engine (measuring oil pressure, revolving speed, temperature, etc.), take extreme care not to get caught in rotating parts or moving parts.
- When raising a heavy component (heavier than 25 kg), use a hoist or crane. Before starting work, check that the slings (wire ropes, webbing slings, chains, and hooks) are free from damage. Always use slings which have ample capacity and install them to proper places. Operate the hoist or crane slowly to prevent the component from hitting any other part. Do not work with any part still raised by the hoist or crane.
- When removing a part which is under internal pressure or under reaction force of a spring, always leave 2 bolts in diagonal positions. Loosen those 2 bolts gradually and alternately to release the pressure, and then remove the part.
- When removing components, do not break or damage the electrical wiring. Damaged wiring may cause a fire.
- When removing piping, do not spill the fuel or oil. If any fuel or oil drips onto the floor, wipe it off immediately. Fuel or oil on the floor can cause you to slip and can even cause fires.
- Do not use gasoline to wash parts as a general rule. Do not use gasoline to clean electrical parts, in particular.

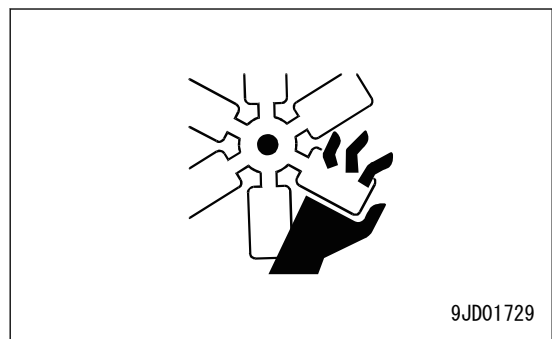
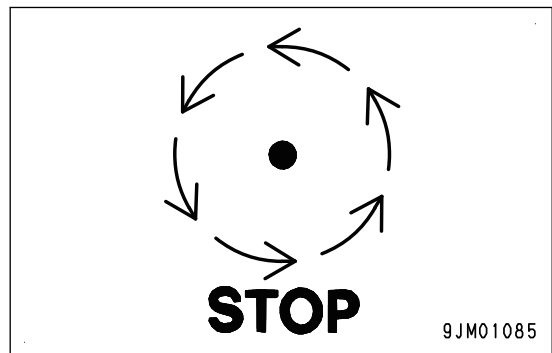



- Be sure to assemble all parts again in their original places. Replace any damaged parts and parts which must not be reused with new parts. When installing hoses and wiring harnesses, be sure that they will not be damaged by contact with other parts when the machine is operated.
- When installing high pressure hoses and tubes, make sure that they are not twisted. Damaged hoses and tubes are dangerous, so be extremely careful when installing hoses and tubes for high pressure circuits. In addition, check that high pressure hoses and tubes are correctly installed.
- When assembling or installing parts, always tighten them to the specified torques. When installing protective parts such as guards, or parts which vibrate violently or rotate at high speed, check again that they are installed correctly.
- Never insert your fingers or hand when aligning 2 holes. Be careful not to get your fingers caught in a hole.
- Check that the measuring tools are correctly installed when measuring hydraulic pressure.
- Take care when removing or installing the tracks of track-type machines. Since the track shoe may separate suddenly when you remove it, never let anyone stand at either end of the track shoe.
- If the engine is operated for a long time in a closed place with poor ventilation, it may cause gas poisoning. Open the windows and doors to ventilate the place well.



## Precautions for slinging work and making signals

- Only one appointed worker must make signals and co-workers must communicate with each other frequently. The appointed signaler must make specified signals clearly at a place where he is well seen from the operator's seat and where he can see the working condition easily. The signaler must always stand in front of the load and guide the operator safely.
  - ⚠ **Never stand under the load.**
  - ⚠ **Do not move a load over a person.**
  - ⚠ **Never step on the load.**
  - ⚠ **Do not prevent the load from swinging or falling down by holding it simply with the hands.**
  - ⚠ **The sling workers and assistant workers other than the guide must move to a place where they are not caught between the load and materials or equipment on the ground or hit by the load even if the crane starts abruptly.**
- Check the slings before starting sling work.
- Keep putting on gloves during sling work. (Put on leather gloves, if available.)
- Measure the weight of the load by the eye and check its center of gravity.
- Use proper sling corresponding to the weight of the load and method of slinging. If too thick wire ropes are used to sling a light load, the load may slip and fall.
- Do not sling a load with 1 wire rope alone. If it is slung so, it may rotate and may slip out of the rope. Install 2 or more wire ropes symmetrically.
  - ⚠ **Slinging with one rope may cause turning of the load during hoisting, untwisting of the rope, or slipping of the rope from its original slinging position on the load, which can result in a dangerous accident.**
- Hanging angle must be 60 ° or smaller as a rule.
- When slinging a heavy load (25 kg or heavier), the hanging angle of the rope must be narrower than that of the hook.

**REMARK**

When slinging a load with 2 or more ropes, the force subjected to each rope increases with the hanging angle. The figure below shows the variation of allowable load in kN {kg} when slinging is made with 2 ropes, each of which is allowed to sling up to 9.8 kN {1000 kg} vertically, at various hanging angles. When the 2 ropes sling a load vertically, they can sling up to 2000 kg of total weight. This weight is reduced to 1000 kg when the 2 ropes make a hanging angle of 120°. If the 2 ropes sling a 2000 kg load at a hanging angle of 150°, each rope is subjected to a force as large as 39.2 kN {4000 kg}.

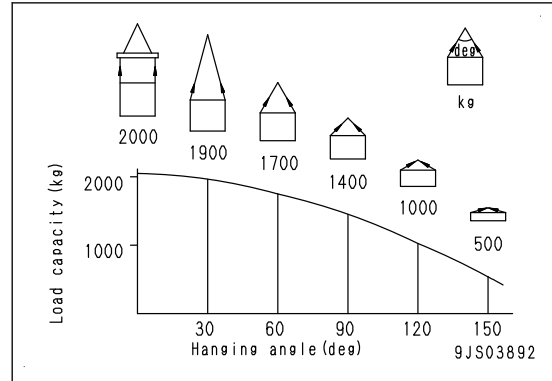

- When installing wire ropes to an angular load, apply pads to protect the wire ropes. If the load is slippery, apply proper material to prevent the wire rope from slipping.
- Use the specified eye bolts and fix wire ropes, chains, etc. to them with shackles, etc.
- Apply wire ropes to the middle part of the hook.

**⚠ Do not use hooks if it does not have a latch system.**

**⚠ Slinging near the tip of the hook may cause the rope to slip off the hook during hoisting.**

**REMARK**

The strength of the hook is maximum at its central part.

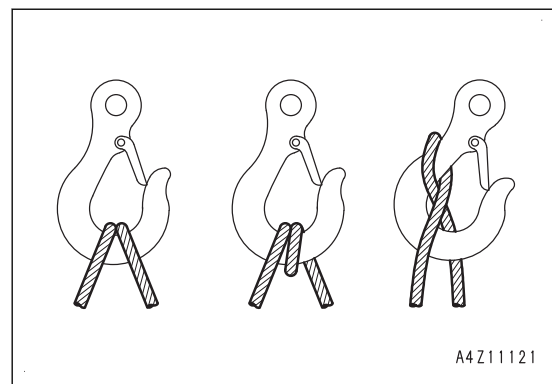

- Never use a wire rope which has breaks in strands (A), reduced diameter (B), or kinks (C). There is a danger that the rope may break during the towing operation.

**Precautions for slinging up**

- Wind in the crane slowly until wire ropes are stretched. When settling the wire ropes with the hand, do not grasp them but press them from above. If you grasp them, your fingers may be caught.
- After the wire ropes are stretched, stop the crane and check the condition of the slung load, wire ropes, and pads.

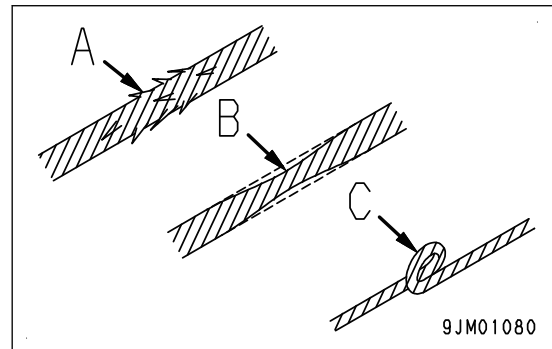

- If the load is unstable or the wire rope or chains are twisted, lower the load and lift it up again.
- Do not lift up the load at an angle.

**Precautions for slinging down**

- When slinging down a load, stop it temporarily at 30 cm above the floor, and then lower it slowly.
- Check that the load is stable, and then remove the sling.
- Remove kinks and dirt from the wire ropes and chains used for the sling work, and put them in the specified place.

**Precautions for using mobile crane****REMARK**

Read Operation and Maintenance Manual of the crane carefully in advance and operate the crane safely.

**Precautions for using overhead traveling crane**

**⚠ When raising a heavy component (heavier than 25 kg), use a hoist or crane.**

**REMARK**

Weight of component whose weight is heavier than 25 kg is shown with symbol  in "DISASSEMBLY AND ASSEMBLY".

- Before starting work, check the wire ropes, brake, clutch, controller, rails, over winding prevention device, ground fault circuit interrupter for electric shock prevention, crane collision prevention device, and energizing caution lamp, and check the following safety items.
  - Observe the signals for sling work.
  - Operate the hoist at a safe place.
  - Be sure to check the directions of the direction indication plate (north, south, east and west) and the operating button.
  - Do not sling a load at an angle. Do not move the crane while the slung load is swinging.
  - Do not raise or lower a load while the crane is moving longitudinally or laterally.
  - Do not drag a sling.
  - When lifting up a load, stop it just after it becomes off the ground, check the safety, and then lift it up.
  - Consider the travel route in advance and lift up a load to a safe height.
  - Place the control switch in a position where it is not an obstacle to work and passage.
  - After operating the hoist, do not swing the control switch.
  - Remember the position of the main switch so that you can turn off the power immediately in an emergency.
  - If the hoist stops because of a power failure, turn off the main switch. When turning on a switch after it is turned off by the ground fault circuit interrupter, check that the devices related to that switch are not in operating condition.
  - If you find an obstacle around the hoist, stop the operation.
  - After finishing the work, stop the hoist at the specified position and raise the hook to at least 2 m above the floor. Do not leave the sling installed to the hook.

**Selecting wire ropes**

Select adequate ropes depending on the weight of the parts to be hoisted referring to the table below.

**REMARK**

The allowable load is calculated with one sixth (safety factor 6) of the breaking load of the rope.

**Wire rope (JIS G3525 6x37-A type) (Standard Z twist wire ropes without galvanizing)**

Nominal diameter of rope ( mm )	Allowable load ( kN { t } )
10	8.8 {0.9}
12	12.7 {1.3}
14	17.3 {1.7}
16	22.6 {2.3}
18	28.6 {2.9}
20	35.3 {3.6}
25	55.3 {5.6}
30	79.6 {8.1}
40	141.6 {14.4}
50	221.6 {22.6}
60	318.3 {32.4}

## Precautions for disconnecting air conditioner piping

### NOTICE

When replacing the air conditioner unit, air conditioner compressor, condenser or receiver drier, etc., collect the refrigerant (air conditioner gas: R134a) from the air conditioner circuit before disconnecting the air conditioner hoses.

### REMARK

- Ask a qualified person for collecting, adding and filling operations of the refrigerant (air conditioner gas: R134a).
- Never release the refrigerant (air conditioner gas: R134a) to the atmosphere.

**⚠ Put on the protective eyeglasses, gloves and working clothes with long sleeves while you are collecting or filling the refrigerant. Otherwise, when refrigerant gas (R134a) gets in your eyes, you may lose your sight, and when it touches your skin, you may suffer from frostbite.**

- When loosening the nuts fixing air conditioner hoses and tubes, be sure to use 2 wrenches; use one wrench to fix and use the other one to loosen the nut.

## Precautions for air conditioner piping

- When installing the air conditioner piping, be careful so that dirt, dusts and water do not enter the hose.
- Check that the O-rings are fitted to the joints when connecting the air conditioner piping.
- Do not reuse an O-ring because it is deformed and deteriorated if it is used once.
- When removing the O-rings, use a soft tool so that the piping is not damaged.
- Check that the O-ring is not damaged or deteriorated.
- Apply compressor oil for refrigerant (R134a) to O-ring.

### REMARK

Do not apply oil to the threaded portion of a bolt, nut or union.

Manufacturer	Part name
DENSO	ND-OIL8
VALEO THERMAL SYSTEMS	ZXL100PG (PAG46 or equivalent)
SANDEN	SP-10

When tightening nuts of the air conditioner hoses and tubes, be sure to use 2 wrenches. Use one wrench to fix and tighten the nut with the other wrench to the specified torque (Use a torque wrench for tightening).

**REMARK**

- The figure shows an example of fitting of O-ring.
- An O-ring is fitted to every joint of the air conditioner piping.

For tightening torques, see THE OTHER INFORMATION, "Precautions for disconnection and connection of air conditioner piping".

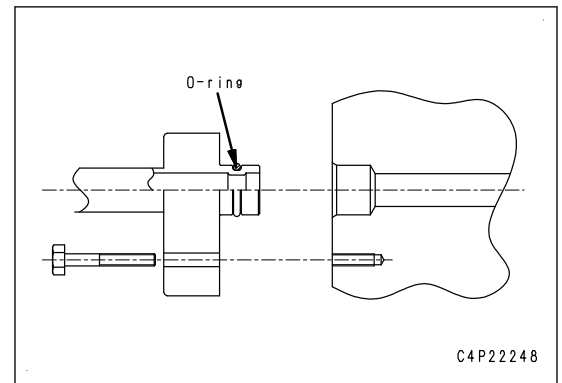
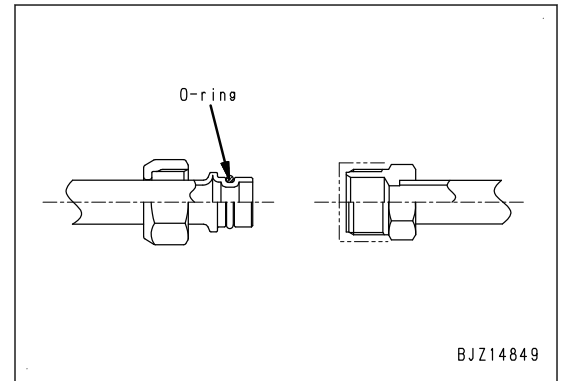

## PRECAUTIONS TO PREVENT FIRE

### Fire caused by fuel, oil, coolant or window washer fluid

Do not bring any open flame close to fuel, oil, coolant or window washer fluid. Always observe the following.

- Do not smoke or use any open flame near fuel or other flammable substances.
- Shut down the engine before adding fuel.
- Do not leave the machine when adding fuel or oil.
- Tighten all the fuel and oil caps securely.
- Be careful not to spill fuel on overheated surfaces or on parts of the electrical system.
- After adding fuel or oil, wipe up any spilled fuel or oil.
- Put greasy rags and other flammable materials into a safe container to maintain safety at the workplace.
- When washing parts with oil, use a non-flammable oil. Do not use diesel oil or gasoline. There is danger that they may catch fire.
- Do not weld or use a cutting torch to cut any pipes or tubes that contain flammable liquids.
- Determine well-ventilated areas for storing oil and fuel. Keep the oil and fuel in the specified place and do not allow unauthorized persons to enter.
- When performing grinding or welding work on the machine, move any flammable materials to a safe place before starting.

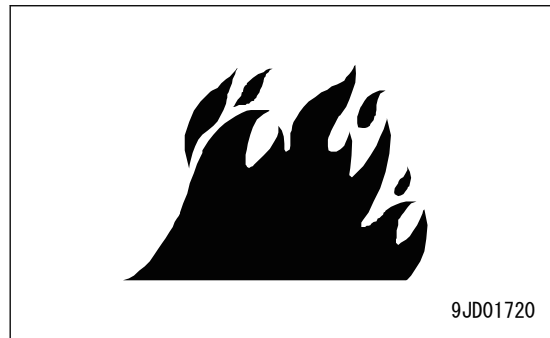

### Fire caused by accumulation or attachment of flammable material

- Remove any dry leaves, chips, pieces of paper, coal dust, or any other flammable materials accumulated or attached to or around the engine exhaust manifold, muffler, or battery, or on the undercovers.
- To prevent fires from being caught, remove any flammable materials such as dry leaves, chips, pieces of paper, coal dust, or any other flammable materials accumulated around the cooling system (radiator, oil cooler) or on the undercover.

### Fire coming from electric wiring

Short circuits in the electrical system can cause fire. Always observe the following.

- Keep all the electric wiring connections clean and securely tightened.
- Check the wiring every day for looseness or damage. Reconnect any loose connectors or refasten wiring clamps. Repair or replace any damaged wiring.

### Fire caused by piping

Check that all the clamps for the hoses and tubes, guards, and cushions are securely fixed in position.

If they are loose, they may vibrate during operation and rub against other parts. There is danger that this may lead to damage to the hoses and cause high-pressure oil to spurt out, leading to fire and serious personal injury or death.

### Fire around the machine due to highly heated exhaust gas

Some models and specifications may be equipped with KDPF (Komatsu Diesel Particulate Filter).

KDPF is a system for purifying exhaust gas by removing soot in exhaust gas. In the process of purification (regeneration), the temperature of discharged exhaust gas may be higher than that of conventional models. Do not bring any flammable materials close to exhaust pipe outlet.

- When there are thatched houses, dry leaves or pieces of paper near the work site, set the system to disable the regeneration before starting work to prevent fire hazards due to highly heated exhaust gas caused by KDPF regeneration.  
See the Operation and Maintenance Manual for the setting procedure.

### **Explosion caused by lighting equipment**

- When checking fuel, oil, battery electrolyte, or coolant, always use lighting equipment with anti-explosion specifications.
- When taking the electrical power for the lighting equipment from the machine, follow the instructions in the Operation and Maintenance Manual.

**ACTIONS IF FIRE OCCURS**

- Turn the starting switch to OFF position to stop the engine.
- Use the handrails and steps to get off the machine.
- Do not jump off the machine. You may fall and suffer serious injury.
- The fumes generated by a fire contain harmful materials which have a bad influence on your body when they are inhaled.  
Do not breathe the fumes.
- After a fire, there may be harmful compounds left. If they touch your skin they may have a bad influence on your body.  
Be sure to wear rubber gloves when handling the materials left after the fire.  
The material of the gloves, which is recommended is polychloroprene (Neoprene) or polyvinyl chloride (in the lower temperature environment).  
When wearing cotton work gloves, wear rubber gloves under them.



## PRECAUTIONS FOR DISPOSING OF WASTE MATERIALS

To prevent pollution, pay full attention to the way to dispose of waste materials.

- Always drain the oil from your machine in containers. Never drain the oil and coolant directly onto the ground or dump into the sewage system, rivers, seas, or lakes.
- Obey appropriate laws and regulations when disposing of harmful objects such as oil, fuel, coolant, solvent, filters, batteries, and DEF.

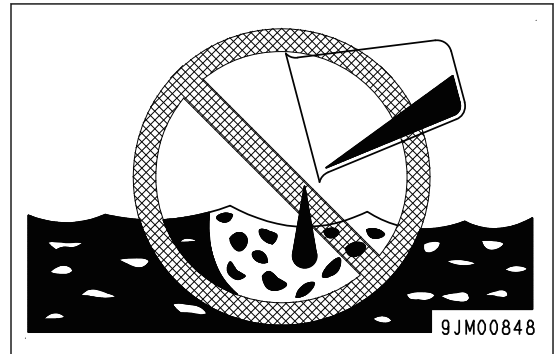

Avoid exposure to burning rubber or plastics which produce a toxic gas that is harmful to people.

- When disposing of parts made of rubber or plastics (hoses, cables, and harnesses), always comply with the local regulations for disposing industrial waste products.

## ACTIONS TAKEN TO MEET EXHAUST GAS REGULATIONS

This machine conforms to either regulation of Tier4 Final (North America) or Stage IV (Europe).

This machine is equipped with the following two exhaust gas treatment systems:

- **Komatsu Diesel Particulate Filter (hereafter KDPF):** A device which captures soot in the exhaust gas to purify exhaust gas. This process performs the combustion of soot referred to as "regeneration".
- **Urea SCR system:** A device which decomposes the toxic nitrogen oxides (NOx) mixed in the exhaust gas into harmless nitrogen and water. Spraying aqueous urea solution into the exhaust gas produces a reaction between the nitrogen oxides and ammonia generated from the urea solution and decomposes the nitrogen oxides into nitrogen and water.

Either AdBlue<sup>®</sup> or DEF may be used as the aqueous urea solution for the SCR system.

AdBlue<sup>®</sup> is a registered trade-mark of VDA (Verband der Automobilindustrie e.V.: Automobile Association of Germany).

DEF is the abbreviation for Diesel Exhaust Fluid.

Commercial DEF that is API approved and meets all the requirements defined in ISO 22241-1.

This solution will be represented as DEF throughout this manual.

### About DEF

DEF is necessary for the urea SCR system. DEF is a colorless transparent 32.5% aqueous urea solution. Urea as main constituent is a material which is used for cosmetics, medical and pharmaceutical products, and fertilizer, etc.

If you add any additional additive agents or water to DEF and use it, the devices will not function properly, and conformance to the exhaust gas regulations will be lost. In addition, it will cause failure of the machine.

- In Europe, use AdBlue<sup>®</sup>.
- In North America, use DEF (Diesel Exhaust Fluid) which is certified by API (American Petroleum Institute). The certified DEF has the API DEF Certification Mark shown as follows. Look for the API DEF Certification Mark when purchasing DEF.

API Diesel Exhaust Fluid Certification Mark is the trade mark of API (American Petroleum Institute).



## PRECAUTIONS FOR DEF

### GENERAL CHARACTER AND PRECAUTIONS FOR HANDLING

DEF is a colorless transparent 32.5% aqueous urea solution. Urea as main constituent is a material which is used for cosmetics, medical and pharmaceutical products, and fertilizer, etc. The following situations require immediate action:

- If it gets on your skin, it may cause inflammation. Immediately take the contaminated clothes or shoes off and wash it off with water. In addition, use a soap to wash it off thoroughly. If your skin becomes irritated or begins to hurt, immediately consult a doctor for treatment.
- Do not induce vomiting if swallowed. If swallowed, thoroughly rinse mouth with water and consult a doctor for treatment.
- Avoid contact with the eyes. If there is contact, flush with clean water for several minutes and consult a doctor for treatment.
- Wear protective eyeglasses when exposed to DEF to protect from solution splashing in your eyes. Wear rubber gloves when you perform work handling DEF to avoid skin contact.

### PRECAUTIONS FOR ADDING

Do not put fluid other than DEF into DEF tank. If diesel fuel or gasoline is added into the tank, it can cause a fire. Some fluids or agents added can create and emit a toxic gas.

When opening the cap of DEF tank of the machine, the ammonia vapor may escape. Keep your face away from the filler port during opening or refilling.

### PRECAUTIONS FOR STORING

If the temperature of AdBlue/DEF becomes high, harmful ammonia gas may be generated. Completely seal up its container for storage. When opening the container, perform it where there is good ventilation. For storage, see "STORE AdBlue/DEF".

Store AdBlue/DEF avoiding direct sunlight. Always use the original container at the time of purchase. Do not exchange the container of AdBlue/DEF with another one. If AdBlue/DEF is stored in an iron or aluminum container, toxic gas may develop and a chemical reaction may corrode the container.

### PRECAUTIONS FOR FIRE HAZARD AND LEAKAGE

AdBlue/DEF is non-flammable; however, in the case of a fire it may generate an ammonia gas. Act on the base of "Actions if fire occurs".

If AdBlue/DEF is spilled, immediately wipe and wash the area with water. If spilled AdBlue/DEF is left unattended and the area is not wiped and cleaned, toxic gas or corrosive substance may be produced by chemical reactions.

### THE OTHER PRECAUTIONS

When disposing of AdBlue/DEF, treat it as an industrial waste. For the waste treating method, refer to "Precautions for disposing of waste materials". It should be treated in the same way.

Never use an iron or aluminum container when disposing AdBlue/DEF fluid, because toxic gas may develop and a chemical reaction may corrode the container. Use a container made of resin (PP, PE) or stainless steel when handling the fluid waste of AdBlue/DEF.

Do not touch any fluid discharged from urea SCR. This fluid becomes acid by the influence of sulphur in the fuel or built-in oxidation catalyzer. If it gets on your skin, thoroughly wash it off with water.

Never relocate or modify the exhaust gas after-treatment device. The harmful gas may be exhausted and it can cause serious damage to the environment as well as violation of laws.

## STORE AdBlue/DEF

- If the temperature of AdBlue/DEF becomes high, harmful ammonia gas may be generated. Completely seal up its container for storage. Only open containers in a well-ventilated area.
- Store AdBlue/DEF avoiding direct sunlight. Always use the original container at the time of purchase. Do not exchange the container of AdBlue/DEF with another one. If AdBlue/DEF is stored in an iron or aluminum container, toxic gas may develop and a chemical reaction may corrode the container.
- AdBlue/DEF freezes at  $-11\text{ }^{\circ}\text{C}$ . The recommended temperature for storage is  $-5\text{ }^{\circ}\text{C}$  or above.

The relation between the upper limit of storage temperature and the storage period of AdBlue/DEF is shown in the table.

Temperature of storage area	Storage period
Max.10 °C	Up to 36 months
Max.25 °C	Up to 18 months
Max.30 °C	Up to 12 months
Max.35 °C	Up to 6 months

\*: Do not store AdBlue/DEF in the temperature of  $35\text{ }^{\circ}\text{C}$  or above.

## Handling AdBlue/DEF in cold weather

- AdBlue/DEF freezes at  $-11\text{ }^{\circ}\text{C}$ .  
AdBlue/DEF may freeze and expand to break the devices and parts in the tank. The parts inside the tank may be affected. Add AdBlue/DEF to the specified amount for cold weather (below the level of when AdBlue/DEF may freeze).
- In cold weather, keep AdBlue/DEF or the machine installed with AdBlue/DEF in the indoors where the temperature is at  $-11\text{ }^{\circ}\text{C}$  or higher to prevent AdBlue/DEF in the tank from freezing.  
If AdBlue/DEF or the machine installed with AdBlue/DEF cannot be stored in the indoors where the temperature is at  $-11\text{ }^{\circ}\text{C}$  or higher (if they are left outdoors in cold weather), AdBlue/DEF in the tank may freeze. Drain AdBlue/DEF to prevent it from freezing.

## PRECAUTIONS FOR HANDLING HYDRAULIC EQUIPMENT

Because of the higher pressure and more precise hydraulic components, the most common cause of a failure is dust (foreign material) in the hydraulic circuit. The special care must be taken when adding hydraulic oil, or when disassembling, or assembling the hydraulic components.

### Select an appropriate workplace

- In rain or high winds, or in dusty environment, avoid adding hydraulic oil, replacing filters, or repairing the machine.

### Disassembly and maintenance work in the field

**⚠ Any component may jump out or oil may spurt out by the remaining pressure in the hydraulic circuit and it may result in serious personal injury or death when removing and disassembling of the hydraulic equipment is performed.**

**⚠ Release the remaining pressure from the hydraulic circuit always before performing the work.**

- In the field, there is a risk of dust entering the component during disassembling or maintenance work, and performance check is hardly performed. Replacement of the assembly is recommended.
- Perform disassembling and maintenance work in the dust proof area.

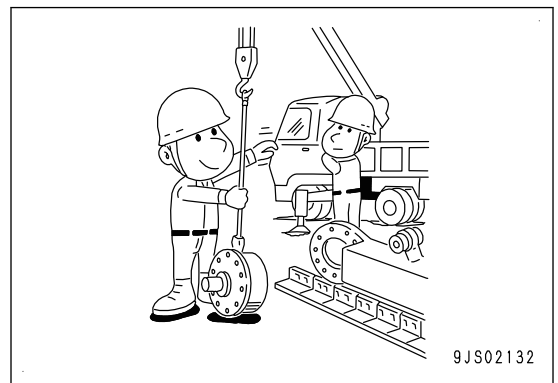

### Sealing of openings (prevention of flowing out of oil)

Plug the openings of the piping and the device which have been removed to prevent foreign material from entering and oil from flowing out.

#### NOTICE

**Do not expose the openings or stuff it, otherwise foreign material may enter or leaked oil may pollute the environment.**

**Do not discard the oil inconsiderately. Ask the customer for disposal or bring it back to dispose it appropriately.**

#### REMARK

Cover the places tightly with caps, tapes, or plastic bags if it is hard to provide the plugs.

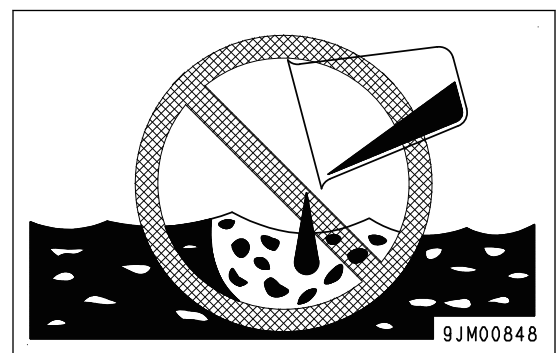

## Preventing intrusion of foreign materials during refilling

- During refilling with the hydraulic oil, do not let water enter the electrical components.
- Clean the oil filler port and its around, refilling pump, oil jug, or etc.
- Refilling by using an oil cleaning device is better method since it can filtrate the contaminants accumulated in the oil during storage.

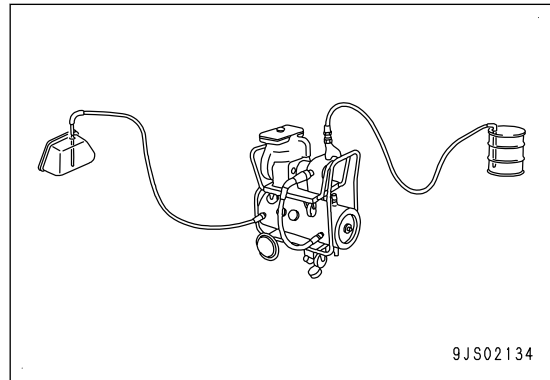

## Replacing hydraulic oil while its temperature is high

- The higher the oil temperature is, the softer the oil is, and the smoother the oil runs. Also, the sludges are easily discharged from the circuit. Perform the replacement while oil temperature is high.
- Old hydraulic oil needs to be drained as much as possible when replacing.

### NOTICE

Old hydraulic oil contaminates the new one if it is mixed since it contains contaminants and sludges, and the service life of the hydraulic oil is shortened.

### REMARK

Drain the old hydraulic oil not only from the hydraulic tank but also from the filter and drain plug in the circuit.

## Avoid reusing the hydraulic oil and lubricating oil

Avoid reusing the hydraulic oil and lubricating oil which has been drained from the machine.

If reused, any foreign material may enter the hydraulic equipment, and it may cause a failure.

## Flushing operation

- Flushing is required to completely dislodge the contaminants and sludges, and existing oil containing those inside the hydraulic circuit after disassembling and assembling, and when replacing the oil with the new one.
- Normally, flushing is performed twice. Primary flushing is performed by using the flushing oil (1) and the secondary flushing is performed by using the specified hydraulic oil.

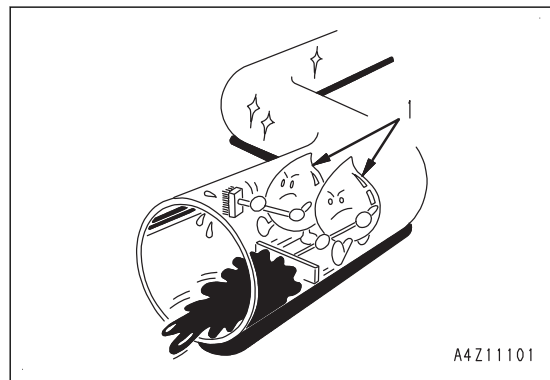

## Cleaning operation

Perform oil cleaning to remove the contaminants and sludges in the hydraulic circuit after repair of the hydraulic device (pump, or control valve) or during operation of the machine.

**REMARK**

The oil cleaning equipment can remove the ultra fine (approximately 3  $\mu\text{m}$ ) particles that the filter built in the hydraulic equipment cannot remove. So, it is very effective device.

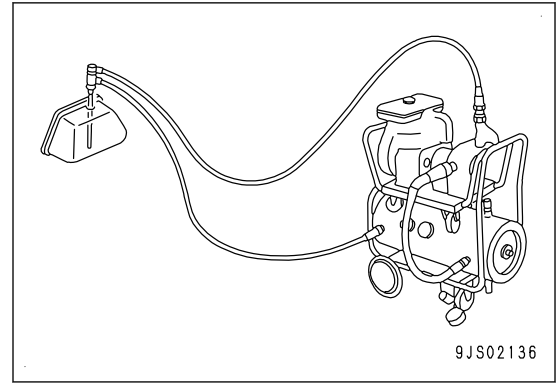

## PRECAUTIONS FOR DISCONNECTION AND CONNECTION OF PIPINGS

When performing "testing and adjusting" of the machine, "removal and installation" and "disassembly and assembly" of the components, observe the following precautions.

### Precautions for removal and disassembling work

- If the cooling water contains coolant, dispose of it correctly as chemicals. Do not drain it to the sewage rashly.
- After disconnecting the hoses or tubes, plug them to prevent dust from entering.
- When draining oil, prepare a container with sufficient capacity.
- Check the matchmarks which indicate the installing position, and put matchmarks on the places where they seem necessary before removal of the components to prevent any mistake when assembling.
- To prevent any excessive force from being applied to the wiring, always hold the connectors when disconnecting the connectors. Do not pull the wires.
- Attach the tags to wires and hoses so that installation is done to the correct installing positions.
- Check the thickness and number of shims when storing shims.
- When hoisting the components, prepare the slings with sufficient strength.
- When using forcing screws to remove any component, tighten the forcing screws uniformly and alternately.
- Before removing any component, clean the surrounding area and cover the component to prevent any foreign material from entering after removal.
- After disconnecting the piping or removing a pipe joint, install the following plugs.

#### NOTICE

When disassembling the machine, check the part number by referring to the Parts Book and use the appropriate parts according to the usage conditions.

#### REMARK

The part numbers of O-ring shown in the table indicate the temporary part number when disassembling and transporting the machine.

### Introduction of parts for the disassembly of the face seal type hoses and tubes

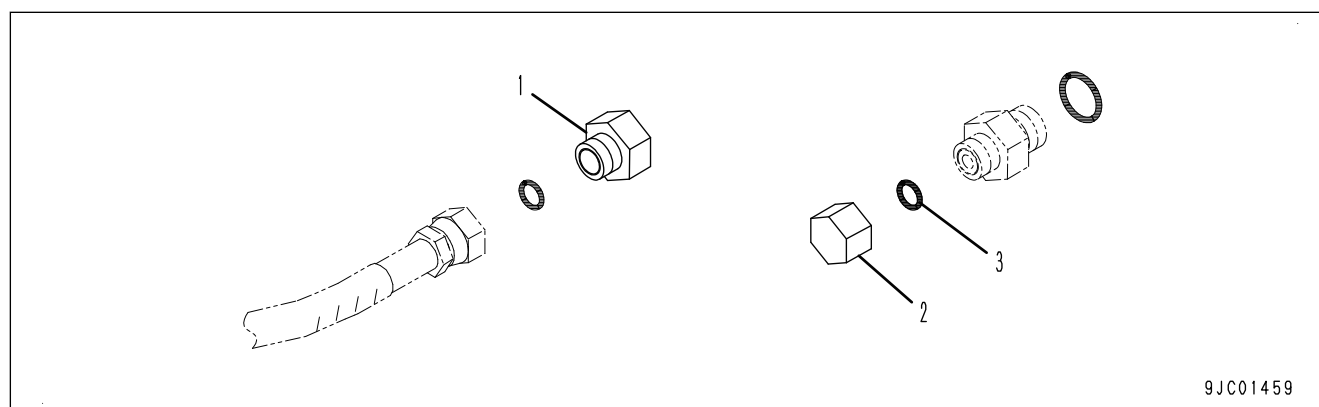

Nominal No.	Hose side	Pipe joint side	O-ring (3)
	Plug (1)	Nut (2)	
02	07376-70210	02789-00210	02896-11008
03	07376-70315	02789-00315	02896-11009
04	07376-70422	02789-00422	02896-11012
05	07376-70522	02789-00522	02896-11015
06	07376-70628	02789-00628	02896-11018



**Introduction of parts for the disconnection of the taper seal type hoses and tubes**

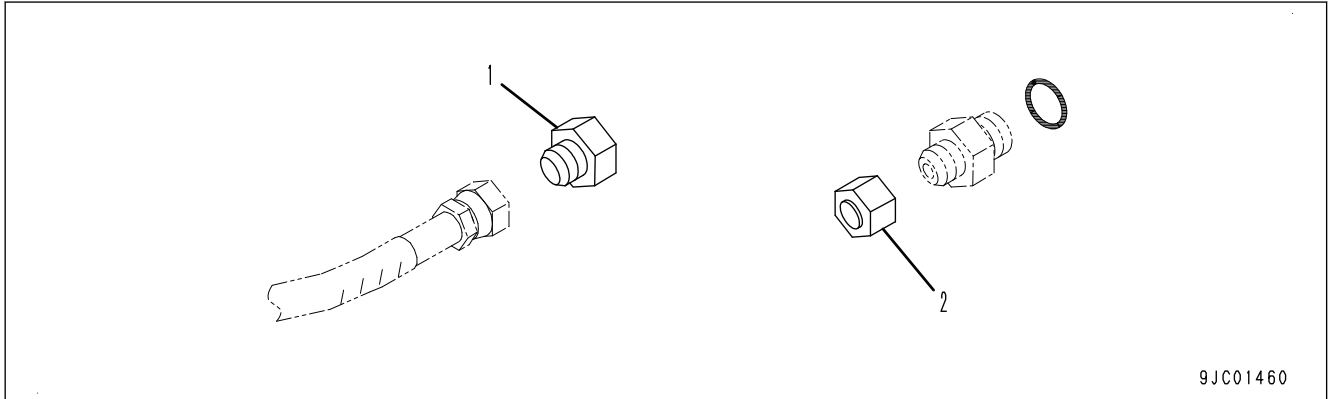

9JC01460

Nominal No.	Hose side	Pipe joint side
	Plug (1)	Nut (2)
02	07376-50210	07222-00210
03	07376-50315	07222-00312
04	07376-50422	07222-00414
05	07376-50522	07222-00515
06	07376-50628	07222-00616
10	07376-51034	07222-01018
12	07376-51234	07222-01219
14	07376-51443	07222-01422

**Introduction of parts for the disconnection of the split flange type hoses and tubes**

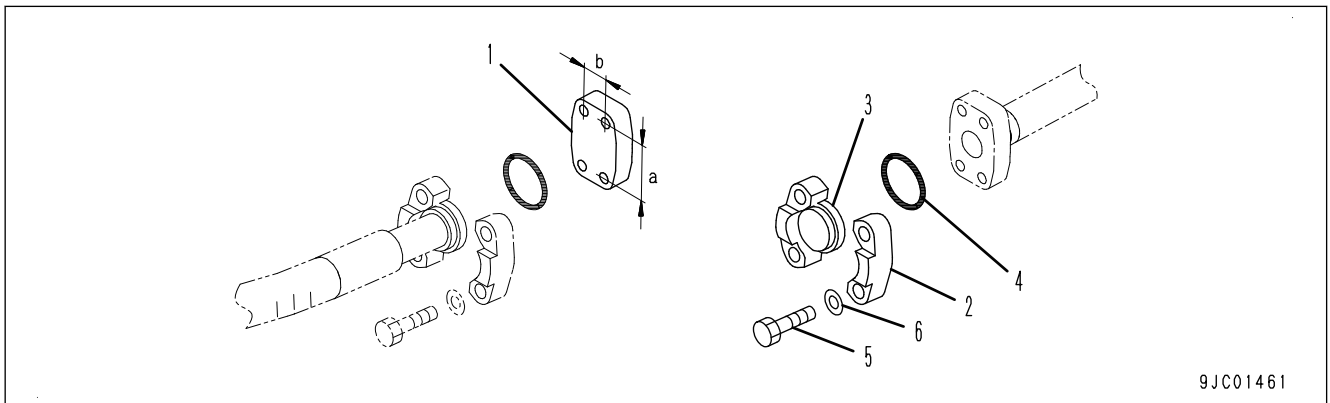

9JC01461

Nominal No.	Bolt pitch (mm)		Hose side	Tube side		O-ring (4)	Bolt (5)	Washer (6)
	a	b	Flange (1)	Split flange (2)	Sleeve head (3)			
04	38.1	17.5	07379-00400	07371-30400	07378-10400	07000-12021	01010-80825	01643-50823
05	42.9	19.8	07379-00500	07371-30500	07378-10500	07000-13022	01010-80830	01643-50823
06	47.6	22.2	07379-00640	07371-30640	07378-10600	07000-13025	07372-51035	01643-51032
10	52.4	26.2	07379-01044	07371-31049	07378-11000	07000-13032	07372-51035	01643-51032

Nominal No.	Bolt pitch (mm)		Hose side	Tube side		O-ring (4)	Bolt (5)	Washer (6)
	a	b	Flange (1)	Split flange (2)	Sleeve head (3)			
12	58.7	30.2	07379-01250	07371-31255	07378-11200	07000-13038	07372-51035	01643-51032
	66.7	31.8	07379-01260	07371-51260	07378-11210	07000-13038	01010-81245	01643-51232
14	69.9	35.8	07379-01460	07371-31465	07378-11400	07000-13048	07372-51240	01643-51232
	79.4	36.5	07379-01470	07371-51470	07378-11410	07000-13048	01010-81455	01643-31445
20	77.8	42.8	07379-02071	07371-32076	07378-12000	07000-12060	07372-51240	01643-51232
	96.8	44.5	07379-02080	07371-52080	07378-12010	07000-12060	01010-81865	01643-31845
24	88.9	50.8	07379-02484	07371-12484	07378-12400	07000-12070	07372-51240	01643-51232
30	106.4	62	07379-03010	07371-13010	07378-13000	07000-12085	07372-51650	01643-51645
34	120.6	69.8	07379-03411	07371-13411	07378-13400	07000-12100	07372-51650	01643-51645
40	130.2	77.8	07379-04012	07371-14012	07378-14000	07000-12110	07372-51650	01643-51645
50	152.4	92	07379-05011	07371-15011	07378-15000	07000-12135	07372-51655	01643-51645

**Introduction of parts for the removal of O-ring boss type joint**

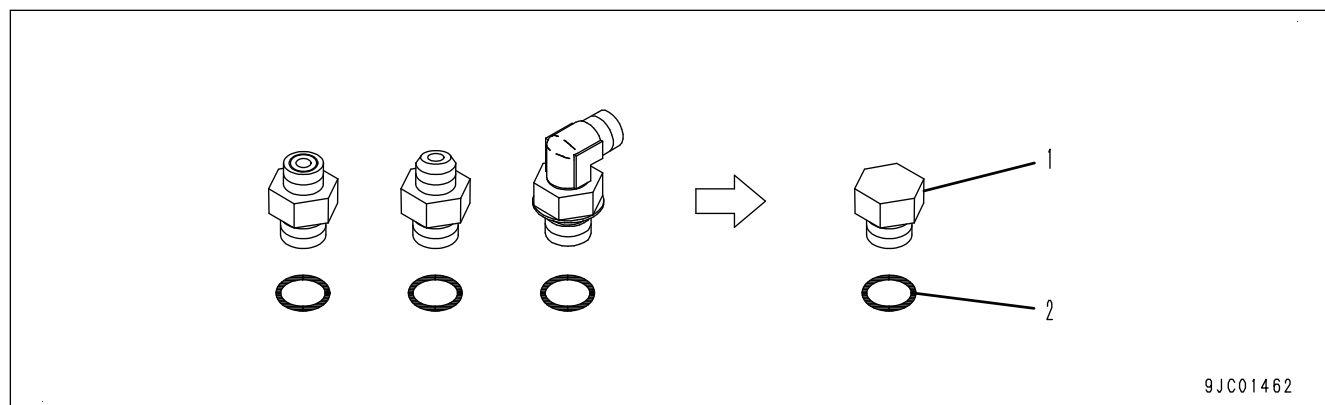

Nominal No.	Plug (1)	O-ring (2)
08	07040-10807	07002-10823
10	07040-11007	07002-11023
12	07040-11209	07002-11223
14	07040-11409	07002-11423
16	07040-11612	07002-11623
18	07040-11812	07002-11823
20	07040-12012	07002-12034
24	07040-12412	07002-12434
30	07041-13012	07002-13034
33	07040-13316	07002-13334
36	07041-13612	07002-13634
42	07040-14220	07002-14234
52	07040-15223	07002-15234

## Introduction of parts for the removal of taper pipe thread type joint

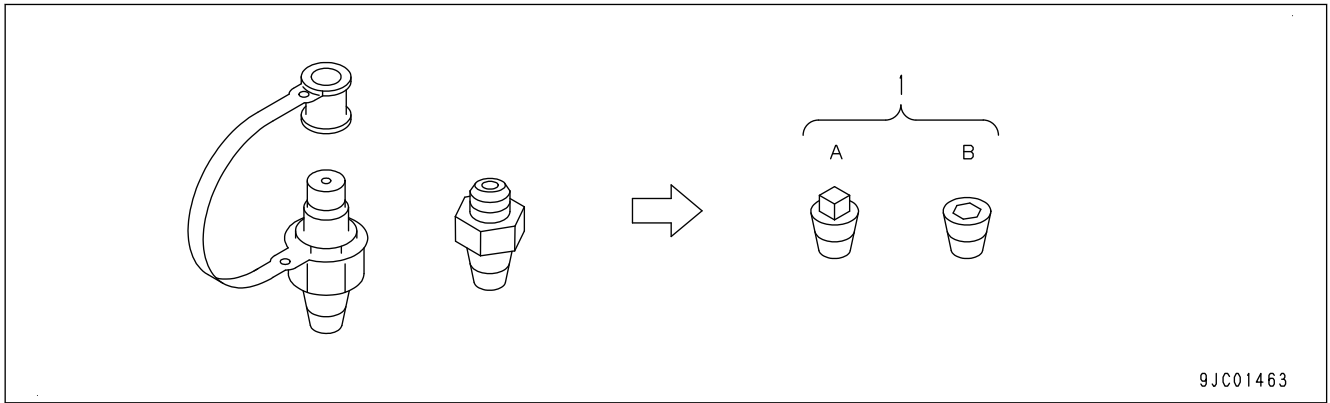

9JC01463

Nominal No.	Nominal thread size	Plug (1)	
		Square head type (A)	Hexagonal socket head (B)
01	R <sup>1</sup> / <sub>8</sub>	07042-00108	07043-00108
02	R <sup>1</sup> / <sub>4</sub>	07042-00211	07043-00211
03	R <sup>3</sup> / <sub>8</sub>	07042-00312	07043-00312
04	R <sup>1</sup> / <sub>2</sub>	07042-00415	07043-00415
06	R <sup>3</sup> / <sub>4</sub>	07042-00617	07043-00617
10	R1	07042-01019	07043-01019
12	R1 <sup>1</sup> / <sub>4</sub>	07042-01222	07043-01222
14	R1 <sup>1</sup> / <sub>2</sub>	07042-01422	07043-01422
20	R2	07042-02026	07043-02026

## Precautions for installation and assembling work

- Tighten the bolts and nuts (sleeve nuts) to the specified torque (KES) unless otherwise specified.
- Install the hoses without twist and interference. If there is any in-between clamp, securely fasten it.
- Replace all of the gaskets, O-rings, cotter pins, and lock plates with new ones.
- Bend the cotter pins and lock plates securely.
- When applying adhesive, clean and degrease the surface to apply, and apply 2 to 3 drops of adhesive to the threaded portion.
- When applying liquid gasket, clean and degrease the surface, and apply it uniformly after making sure that the surface is free from dust or damage.
- Clean all of the parts. If there is any damage, dents, burrs, or rust found on them, repair it.
- Apply engine oil to the rotating parts and sliding surface.
- Apply molybdenum disulfide lubricant (LM-P) to the surfaces of the press-fitting parts.
- After installing the snap ring, check that the snap ring is settled in the ring groove completely.
- When connecting wiring harness connectors, clean the connectors to remove oil, dust, or water, then connect them securely.
- Use the eye bolts without fatigue and deformation and screw them in securely. Match the directions of the eyes and the hook.
- When installing split flanges, tighten the bolts uniformly and alternately to prevent uneven tightening.
- As a rule, apply liquid gasket (LG-5) or liquid sealant (LS-2) to the threaded portion of each taper male screws which receive pressure.

**REMARK**

If the threaded portion is difficult to degrease, you may use a seal tape.

When winding a seal tape onto a right-handed taper male screw, start winding the screw clockwise from the third thread in the advancing direction of the threads seeing from the screw end.

**NOTICE**

**If the seal tape is wound counterclockwise, it may become loose when screwed in, and it may come off. If the sealed tip is pushed outside, it may cause oil leakage.**

**NOTICE**

**When assembling the hydraulic equipment such as cylinders, pumps and pipings which are removed, be sure to bleed air from the hydraulic circuit before operating it for the first time according to the following procedure.**

1. Start the engine, and run it at low idle.
2. Perform the operation to extend and retract each cylinder of the work equipment and stop it at approximately 100 mm before the stroke end for 4 or 5 times.
3. Perform the operation to extend and retract each cylinder of the work equipment and stop it at the stroke end for 3 or 4 times.

**NOTICE**

**After repair is finished, when operating the machine which has been stored for a long period, bleed air from the hydraulic circuit according to the same procedure.**

**Precautions at the time of completion of work**

**Refilling of coolant or water or oil, greasing, and adding of AdBlue/DEF**

- For machines with urea SCR system, fill AdBlue/DEF to the specified level before starting the engine.
- Supply the specified amount of grease to the work equipment parts.
- When the coolant is drained, be sure that the drain valve is securely tightened, then refill the coolant reservoir with the coolant Komatsu recommends to the specified level. Start the engine to circulate the coolant in the piping, and add the coolant to the specified level again.
- When the hydraulic components are removed and installed, refill the tank with the oil Komatsu recommends to the specified level. Start the engine to circulate the oil in the piping, and add the oil to the specified level again.
- If the hydraulic piping or hydraulic equipment is removed, be sure to bleed air from the system after rebuilding the parts, by referring to TESTING AND ADJUSTING.

**Testing installed condition of cylinder heads and manifolds**

- Check the cylinder head and intake and exhaust manifold mountings for looseness.
- If there is any looseness, retighten the part.

**REMARK**

For the tightening torques, see "DISASSEMBLY AND ASSEMBLY".

**Test engine piping for damage and looseness**

**Intake and exhaust system**

Check that there is no damage on the pipings, or no looseness on mounting bolts, nuts and clamps, or no leak of air or exhaust gas from connecting portion.

If there is any looseness, damage, or gas leak, retighten or repair the part.

**Cooling system**

Check that there is no damage on the pipings, no looseness on mounting bolts, nuts and clamps, and no water leak from connecting portion.

If there is any looseness, damage, or water leak, retighten or repair the part.

**Fuel system**

Check that there is no damage on the pipings, no looseness on mounting bolts, nuts and clamps, and no fuel leak from connecting portion.

If there is any looseness, damage, or fuel leak, retighten or repair the part.

**Check the exhaust equipment and its installation portion for looseness and damage.**

**REMARK**

When an equipment is described as an exhaust equipment, it is one of the followings. (The applications or components of equipment are different depending on its models or specifications.)

- KDPF
- AdBlue/DEF mixing tube
- SCR assembly
- KDOC muffler
- Muffler
- Exhaust pipe
- Parts which connects the above, or etc.

Visually check that there is no crack or no damage on the exhaust equipment and its installation portion. If there is any damage, replace the part.

Check that there is no looseness on the exhaust equipment and mounting bolts, nuts, and clamps on the installation portion.

If there is any looseness, retighten the part.

**Check of function of muffler in exhaust system**

**REMARK**

When an equipment is described as an muffler in exhaust system, it is one of the followings. (The applications or components of equipment are different depending on its models or specifications.)

- KDPF
- AdBlue/DEF mixing tube
- SCR assembly
- KDOC muffler
- Muffler
- Exhaust pipe
- Parts which connects the above, or etc.

Check that there is no unusual noise by comparing to it of the time when the machine was new.

If there is any unusual noise, repair KDPF or muffler, referring to "TROUBLESHOOTING" and "DISASSEMBLY AND ASSEMBLY".

## PRECAUTIONS FOR HANDLING ELECTRICAL EQUIPMENT

To maintain the performance of the machine over a long period, and to prevent failures or troubles before they occur, correct "operation", "maintenance and inspection" "troubleshooting", and "repairs" must be performed. This section deals particularly with correct repair procedures for mechatronics components and is aimed at improving the quality of repairs. For this purpose, it describes the working procedures in "Handling of electrical equipment".

### Handling wiring harnesses and connectors

- Wiring harnesses consist of wires connecting one component to another component, connectors used for connecting and disconnecting one wire from another wire, and protectors or tubes used for protecting the wires.
- Compared with other electrical components fitted in boxes or cases, wiring harnesses are likely to be directly affected by rain water, heat, or vibration. Furthermore, during inspection and repair operations, they are frequently removed and installed again, so they are likely to suffer deformation or damage. For this reason, it is necessary to be extremely careful when handling and maintenance of the wiring harnesses.
- If AdBlue/DEF is spilled over wiring harness and connectors, it may cause corrosion and defective contact. Be careful not to spill it over electrical equipment, wiring harness and connectors since AdBlue/DEF is strongly corrosive to metal.

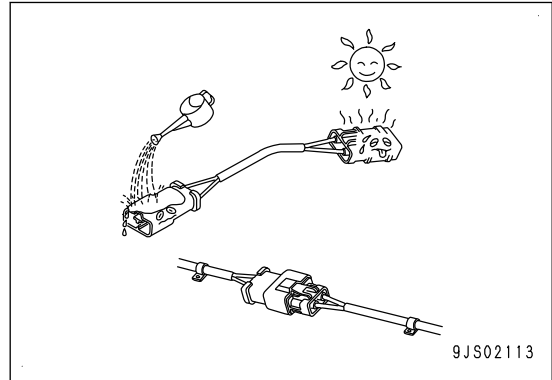

### Main causes of failure in wiring harness

#### Defective contact of connectors (defective contact between male and female connectors)

Problems with defective contact are likely to occur because the male connector is not properly inserted into the female connector, or because one or both of connectors are deformed or the position is not correctly aligned, or because there is corrosion or oxidization of the contact surfaces. The corroded or oxidized contact surfaces may become shiny again (and contact may become normal) by connecting and disconnecting the connectors approximately 10 times.

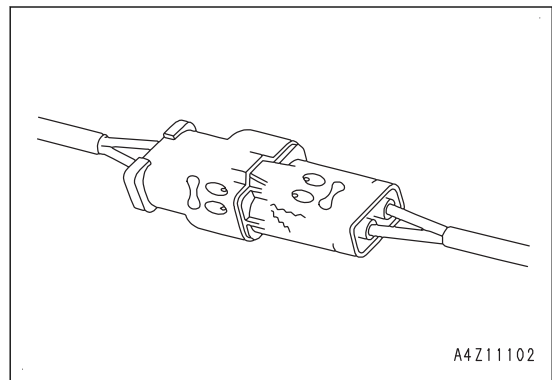

#### Defective crimping or soldering of connectors

The pins of the male and female connectors are attached to wires by crimping or soldering. If excessive force is applied to the wire, the jointed portion (1) may become loose, and it may result in a defective connection or breakage.

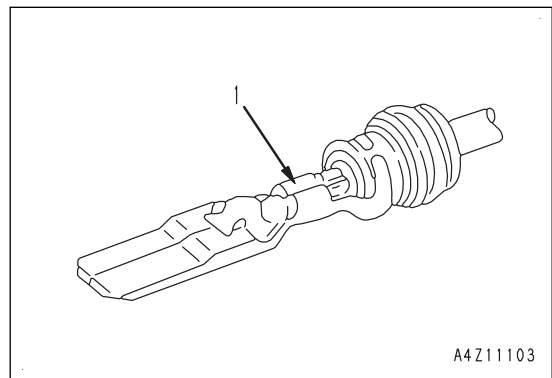

### Disconnection in wiring

If the wiring harness is pulled to disconnect the connector, or the components are lifted with a crane while the wiring harness is still connected, or a heavy object hits the wiring harness, it may separate the crimping of the connector, or damage the soldering, or break the wiring harness.

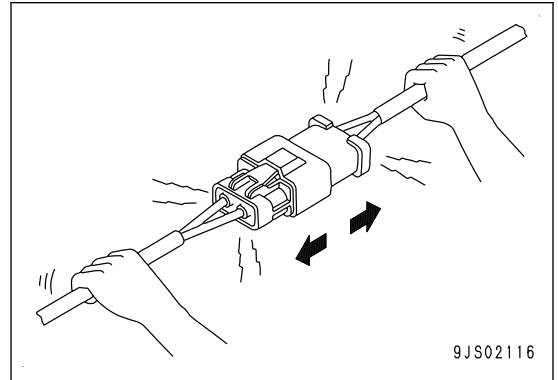

### Water entering the connector by high-pressure jetting

The connector is designed to make it difficult for water to enter (drip-proof structure), but if high-pressure water is sprayed directly on the connector, water may enter the connector, depending on the direction of the water jet.

Do not spray water directly on the connector.

If the connector is waterproof, intruded water is hardly drained. Once water enters into the connector, water goes through pins to cause short-circuit. Drying the drenched connector or take appropriate actions before providing electricity.

### Entry of water, dirt, or dust when disconnecting a connector

If any water, mud or dust is stuck to the outside surface of a connector, it can enter inside the connector when the connector is disconnected. Before disconnecting the connector, wipe off any stuck water or dirt by using a dry cloth or blow it with compressed air.

### Oil, mud, or dust stuck to connector

If any oil or grease is stuck to the connector and an oil film is formed on the mating surface of the male and female pins, the oil prevents electricity from passing through resulting in defective contact. If any oil, grease, dirt or dust is stuck to the connector, wipe it off with a dry cloth or blow it with compressed air, and wash it with electrical contact restorer.

### NOTICE

- When wiping the jointed portion of the connector, do not apply excessive force or deform the pins.
- If there is oil or water in the compressed air, it causes the contacts to become dirtier. Use clean air which any oil and water has been removed from.

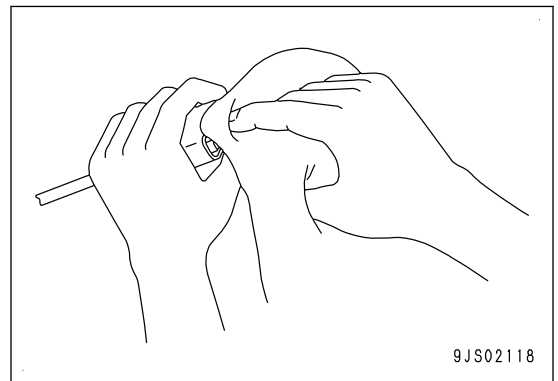
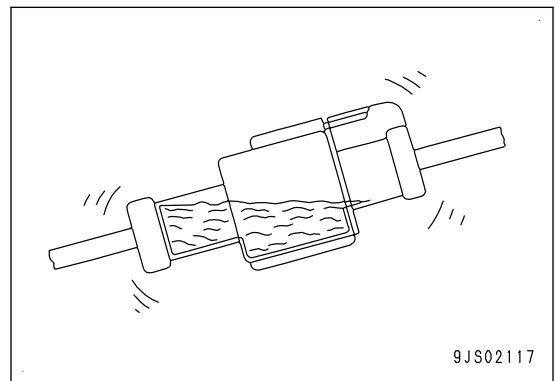

## PRECAUTIONS FOR HANDLING FUEL SYSTEM EQUIPMENT

The machines equipped with common rail fuel injection system (CRI) consists of more precise parts than the parts used in the conventional fuel injection pump and nozzle. If foreign material enters this system, it may cause a failure. Use special care to prevent entry of the foreign material when servicing the fuel system.

### Select an appropriate workplace

Avoid the work of adding hydraulic oil, replacing filters, or repairing the machine in rainy or windy weather, or in dusty environment.

### Sealing the opening

Plug the removed pipes and the openings of the removed components with the caps, tapes, plastic bags, etc. to prevent foreign material from entering.

#### NOTICE

**Do not expose the openings or stuff it, otherwise foreign material may enter or leaked oil may pollute the environment.**

**Do not discard the oil inconsiderately. Ask the customer for disposal or bring it back to dispose it appropriately.**

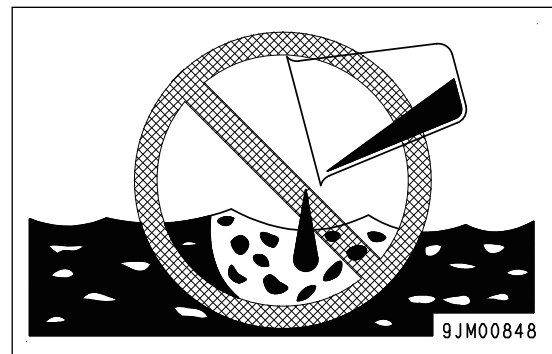

### How to clean parts when dirt is stuck

If any dirt or dust sticks the parts of the fuel system, clean it off thoroughly with clean fuel.

### Precautions for replacing fuel filter cartridge

Be sure to use the Komatsu genuine fuel filter cartridge.

#### NOTICE

**The machine equipped with common rail fuel injection system (CRI) consists of more precise parts than the parts used in the conventional fuel injection pump and nozzle. In order to prevent foreign material from entering this system, the filter employs a specially high performance of filter element. If a filter other than a Komatsu genuine filter is used, fuel system contamination and damage may occur. Therefore Komatsu recommends using only Komatsu fuel filters and install them following the procedures in the shop manual.**



## **PRECAUTIONS FOR HANDLING INTAKE SYSTEM EQUIPMENT**

The machines equipped with Variable Geometry Turbocharger (VGT) consists of more precise parts (variable system) than the parts used in the conventional turbocharger. If foreign material enters this system, it may cause a failure. Use special care to prevent entry of the foreign material when servicing the intake system.

### **Select an appropriate workplace**

Avoid the work of adding hydraulic oil, replacing filters, or repairing the machine in rainy or windy weather, or in dusty environment.

### **Sealing the opening**

Plug the removed pipes and the openings of the removed components with the caps, tapes, plastic bags, etc. to prevent foreign material from entering.

### **NOTICE**

**Do not expose the openings or stuff it, otherwise foreign material may enter it.**

## PRACTICAL USE OF KOMTRAX

Various information which KOMTRAX system transmits by using the radio communication is useful for KOMTRAX operator to provide various services for the customers.

When KOMTRAX system is installed to the machine and it is enabled, machine information can be checked by KOMTRAX system, and it is used for testing and troubleshooting to be performed efficiently.

Large-sized models are equipped with KOMTRAX Plus which can use more detailed information.

### REMARK

(KOMTRAX may not be installed to the machine in some countries or areas.)

### Merit of using KOMTRAX

- The location where the machine is working at can be checked on the map in a personal computer.
- Operation information such as service meter, operating hours, fuel consumption, and occurred caution as well as failure code can be checked.
- The operator can check the hours used and replacement interval of consumable parts of the machine such as fuel filter, hydraulic oil filter, hydraulic oil and engine oil.
- Information of how machine is operated (idling time, traveling time, digging time, relieving time, etc.) can be checked, and it is used to presume the machine operating condition.
- Various reports such as "Fuel saving operation support", "Operation summary", etc. is generated, and it is utilized as an advice tool for the user and operator.
- KOMTRAX Plus can record the data of abnormality record, trend data, snap shot data, etc. to grasp the soundness of machine, in addition to KOMTRAX function described above. These data can be used on personal computer screens.

### How to make a full use of KOMTRAX

Making use of KOMTRAX enables the following activities.

- Quick response to a request for immediate repair
  1. To check the displayed caution and failure code, etc. through KOMTRAX upon receiving a repair request from a user.
  2. To immediately arrange necessary tools, replacement parts, etc, immediately in accordance with the displayed failure code.
  3. To find the location of the failed machine by using the map of KOMTRAX, to visit the customer there.
- Proactive maintenance
  1. To check the service summary screen of KOMTRAX, to find the machine which has high priority failure code indicated by a red or yellow flag.
  2. To check the condition of the machine with the customer and to make a plan to visit.
  3. To immediately arrange necessary tools, replacement parts, etc, immediately in accordance with the displayed failure code.
- Practice of periodic maintenance and periodic inspection service
  1. To check the service summary screen of KOMTRAX, and to find the machine of which the usage limits for the consumable parts indicated by red flags are over.
  2. To submit an estimate sheet for the consumable parts to be replaced and the labor cost for the replacement work to the customer.
  3. To propose the periodic inspection (Pm clinic, etc.) according to the service meter reading.

### How to operate KOMTRAX

For the operating method of each screen of KOMTRAX, ask KOMTRAX key person in your Komatsu distributor.

## DISCONNECT AND CONNECT PUSH-PULL TYPE COUPLER

### REMARK

- Loosen the oil filler cap of the hydraulic tank slowly to release the remaining pressure in the hydraulic tank.
- Provide an oil container to receive oil since some hydraulic oil flows out when the hose is disconnected even after the remaining pressure is released from the hydraulic tank.

## METHOD FOR DISCONNECTING AND CONNECTING TYPE 1 PUSH-PULL TYPE COUPLER

### Disconnection

1. Hold adapter (1), and push hose joint (2) into mating adapter (3).

#### REMARK

- Push it in approximately 3.5 mm.
- Do not hold rubber cap portion (4).

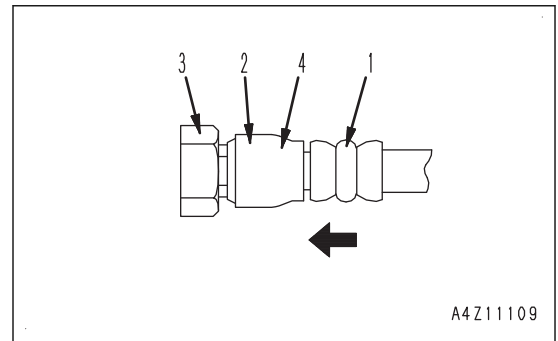

2. While having adapter (3) inserted into hose side joint (2), insert rubber cap (4) to adapter (3) side until it clicks.

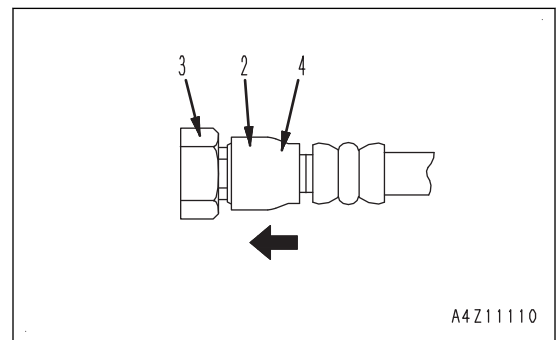

3. Hold hose adapter (1) or hose (5), and pull it out.

#### REMARK

Provide an oil container to receive a quantity of hydraulic oil which may flow out.

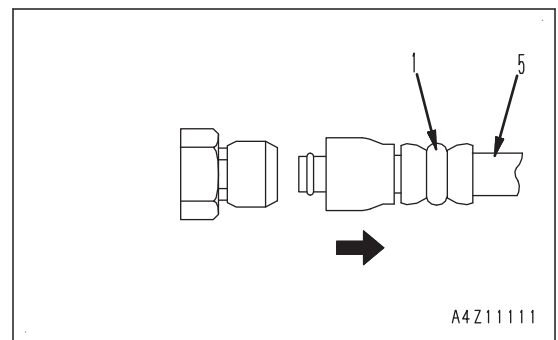

### Connection

1. Hold hose adapter (1) or hose (5), and insert it in mating adapter (3), aligning the axis.

#### REMARK

Do not hold rubber cap portion (4).

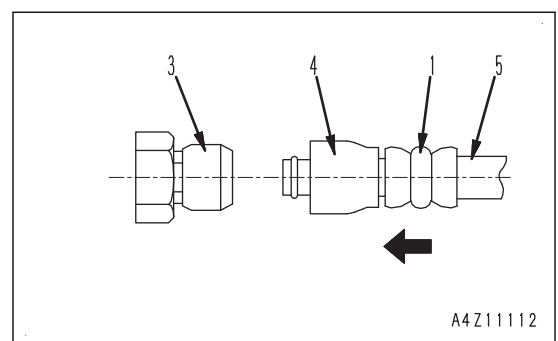

- After inserting the hose in the mating adapter perfectly, pull it back to check the connecting condition.

**REMARK**

When the hose fitting is pulled back, the rubber cap moves approximately 3.5 mm toward the hose, but it is not a problem.

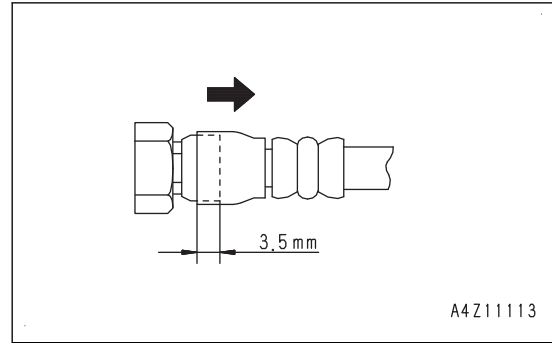

## METHOD FOR DISCONNECTING AND CONNECTING TYPE 2 PUSH-PULL TYPE COUPLER

### Disconnection

- Hold the tightening adapter part and push body (2) straight until sliding prevention ring (1) contacts contact surface (a) of the hexagonal part at the male end.

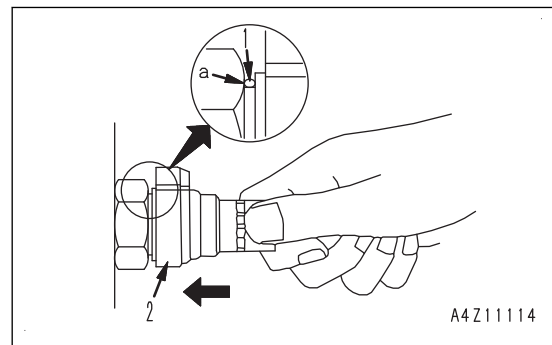

- While keeping the condition of step 1, turn lever (3) to the right (clockwise).

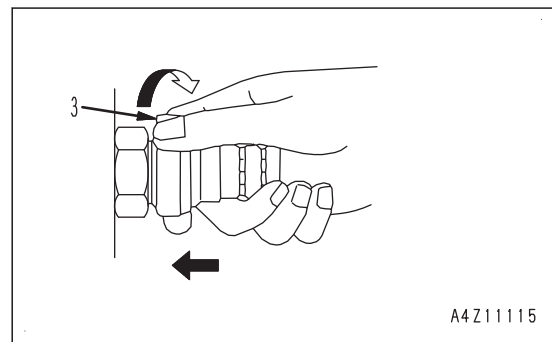

- While keeping the conditions of steps 1 and 2, pull out whole body (2) to disconnect it.

**REMARK**

Provide an container to receive a quantity of hydraulic oil which may flow out.

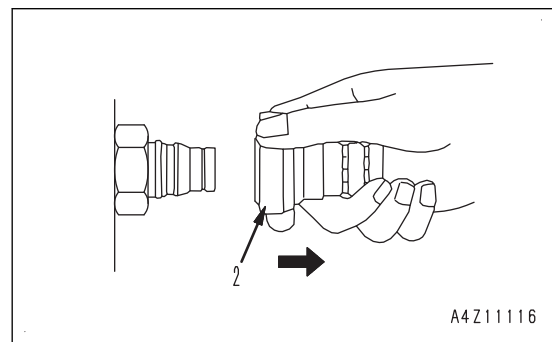

This as a preview PDF file from [best-manuals.com](http://best-manuals.com)



Download full PDF manual at [best-manuals.com](http://best-manuals.com)