

# SERVICE MANUAL

## I650L Crawler Dozer

Part number 47998877  
English  
March 2016





## **SERVICE MANUAL**

**1650L XLT PAT**

# Link Product / Engine

---

<b>Product</b>	<b>Market Product</b>	<b>Engine</b>
1650L XLT PAT	Latin America	F4HE9684U*J101

# Contents

---

## INTRODUCTION

Engine.....	10
[10.001] Engine and crankcase .....	10.1
[10.400] Engine cooling system .....	10.2
[10.310] Aftercooler.....	10.3
[10.304] Engine lubrication system.....	10.4
Rear axle system.....	27
[27.120] Planetary and final drives .....	27.1
[27.126] Spur gear and final drives.....	27.2
Hydrostatic drive.....	29
[29.100] Transmission and steering hydrostatic control .....	29.1
[29.202] Hydrostatic transmission .....	29.2
Brakes and controls .....	33
[33.202] Hydraulic service brakes .....	33.1
Hydraulic systems.....	35
[35.000] Hydraulic systems.....	35.1
[35.104] Fixed displacement pump.....	35.2
[35.310] Distributor and lines .....	35.3
[35.350] Safety and main relief valves .....	35.4
[35.741] Dozer blade cylinders .....	35.5
[35.742] Ripper hydraulic system.....	35.6
Tracks and track suspension.....	48
[48.130] Track frame and driving wheels.....	48.1
[48.110] Front suspension .....	48.2
[48.100] Tracks .....	48.3
[48.134] Track tension units .....	48.4

[48.138] Track rollers .....	48.5
<b>Cab climate control .....</b>	<b>50</b>
[50.100] Heating .....	50.1
[50.200] Air conditioning .....	50.2
<b>Electrical systems .....</b>	<b>55</b>
[55.013] Engine oil system .....	55.1
[55.000] Electrical system .....	55.2
[55.100] Harnesses and connectors .....	55.3
[55.525] Cab engine controls .....	55.4
[55.015] Engine control system .....	55.5
[55.201] Engine starting system .....	55.6
[55.301] Alternator .....	55.7
[55.302] Battery .....	55.8
[55.202] Cold start aid .....	55.9
[55.010] Fuel injection system .....	55.10
[55.012] Engine cooling system .....	55.11
[55.019] Hydrostatic drive control system .....	55.12
[55.050] Heating, Ventilation, and Air-Conditioning (HVAC) control system .....	55.13
[55.408] Warning indicators, alarms, and instruments .....	55.14
[55.101] Chassis harness .....	55.15
[55.014] Engine intake and exhaust system .....	55.16
[55.DTC] FAULT CODES .....	55.17
<b>Dozer blade and arm .....</b>	<b>86</b>
[86.110] Dozer blade .....	86.1
<b>Tools .....</b>	<b>89</b>
[89.128] Ripper assembly .....	89.1
<b>Platform, cab, bodywork, and decals .....</b>	<b>90</b>
[90.150] Cab .....	90.1

[90.114] Operator protections ..... 90.2  
[90.124] Pneumatically-adjusted operator seat..... 90.3





## **INTRODUCTION**



# Contents

---

## INTRODUCTION

Foreword - Important notice regarding equipment servicing .....	3
Foreword - How to use and navigate through this manual .....	4
Safety rules - Ecology and the environment .....	9
Safety rules .....	10
Basic instructions - Shop and assembly .....	11
Torque - Minimum tightening torques for normal assembly .....	13
Torque - Standard torque data for hydraulics .....	18

---

## **Foreword - Important notice regarding equipment servicing**

All repair and maintenance work listed in this manual must be carried out only by qualified dealership personnel, strictly complying with the instructions given, and using, whenever possible, the special tools.

Anyone who performs repair and maintenance operations without complying with the procedures provided herein shall be responsible for any subsequent damages.

The manufacturer and all the organizations of its distribution chain, including - without limitation - national, regional, or local dealers, reject any responsibility for damages caused by parts and/or components not approved by the manufacturer, including those used for the servicing or repair of the product manufactured or marketed by the manufacturer. In any case, no warranty is given or attributed on the product manufactured or marketed by the manufacturer in case of damages caused by parts and/or components not approved by the manufacturer.

The manufacturer reserves the right to make improvements in design and changes in specifications at any time without notice and without incurring any obligation to install them on units previously sold. Specifications, descriptions, and illustrative material herein are as accurate as known at time of publication but are subject to change without notice.

In case of questions, refer to your CASE CONSTRUCTION Sales and Service Networks.

---

## Foreword - How to use and navigate through this manual

This manual has been produced by a new technical information system. This new system is designed to deliver technical information electronically through web delivery (eTIM), DVD, and paper manuals. A coding system called SAP has been developed to link the technical information to other Product Support functions, e.g., Warranty.

Technical information is written to support the maintenance and service of the functions or systems on a customer's machine. When a customer has a concern on their machine it is usually because a function or system on their machine is not working at all, is not working efficiently, or is not responding correctly to their commands. When you refer to the technical information in this manual to resolve that customer's concern, you will find all the information classified using the SAP coding, according to the functions or systems on that machine. Once you have located the technical information for that function or system, you will then find all the mechanical, electrical or hydraulic devices, components, assemblies, and sub assemblies for that function or system. You will also find all the types of information that have been written for that function or system: the technical data (specifications), the functional data (how it works), the diagnostic data (fault codes and troubleshooting), and the service data (remove, install adjust, etc.).

By integrating SAP coding into technical information, you will be able to search and retrieve just the right piece of technical information you need to resolve that customer's concern on his machine. This is made possible by attaching 3 categories to each piece of technical information during the authoring process.

The first category is the Location, the second category is the Information Type and the third category is the Product:

- LOCATION - the component or function on the machine, that the piece of technical information is going to describe (e.g., Fuel tank).
- INFORMATION TYPE - the piece of technical information that has been written for a particular component or function on the machine (e.g., Capacity would be a type of Technical Data describing the amount of fuel held by the fuel tank).
- PRODUCT - the model for which the piece of technical information is written.

Every piece of technical information will have those three categories attached to it. You will be able to use any combination of those categories to find the right piece of technical information you need to resolve that customer's concern on their machine.

That information could be:

- the procedure for how to remove the cylinder head
- a table of specifications for a hydraulic pump
- a fault code
- a troubleshooting table
- a special tool

## Manual content

This manual is divided into Sections. Each Section is then divided into Chapters. Contents pages are included at the beginning of the manual, then inside every Section and inside every Chapter. An alphabetical Index is included at the end of each Chapter. Page number references are included for every piece of technical information listed in the Chapter Contents or Chapter Index.

Each Chapter is divided into four Information types:

- Technical Data (specifications) for all the mechanical, electrical or hydraulic devices, components, assemblies or sub-assemblies.
- Functional Data (how it works) for all the mechanical, electrical or hydraulic devices, components, assemblies or sub-assemblies.
- Diagnostic Data (fault codes, electrical and hydraulic troubleshooting) for all the mechanical, electrical or hydraulic devices, components, assemblies or sub-assemblies.
- Service Data (remove disassemble, assemble, install) for all the mechanical, electrical or hydraulic devices, components, assemblies or sub-assemblies.

## Sections

Sections are grouped according to the main functions or a systems on the machine. Each Section is identified by a number (00, 35, 55, etc.). The Sections included in the manual will depend on the type and function of the machine that the manual is written for. Each Section has a Contents page listed in alphabetic/numeric order. This table illustrates which Sections could be included in a manual for a particular product.

SECTION	PRODUCT					
	Tractors					
	Vehicles with working arms: backhoes, excavators, skid steers, ....					
	Combines, forage harvesters, balers, ....					
	Seeding, planting, floating, spraying equipment, ....					
Mounted equipment and tools, ....						
00 - Maintenance	X	X	X	X	X	
05 - Machine completion and equipment	X	X	X	X	X	
10 - Engine	X	X	X	X		
14 - Main gearbox and drive	X	X	X	X		
18 - Clutch	X	X	X			
21 - Transmission	X	X	X	X		
23 - Four wheel drive (4WD) system	X	X	X	X		
25 - Front axle system	X	X	X	X		
27 - Rear axle system	X	X	X	X		
29 - Hydrostatic drive	X	X	X	X		
31 - Power Take-Off (PTO)	X		X			
33 - Brakes and controls	X	X	X	X		
35 - Hydraulic systems	X	X	X	X		
36 - Pneumatic system	X	X	X	X		
37 - Hitches, drawbars and implement couplings	X		X	X		
39 - Frames and ballasting	X	X	X	X	X	
41 - Steering	X	X	X	X		
44 - Wheels	X	X	X	X		
46 - Steering clutches						
48 - Tracks and track suspension	X	X	X			
50 - Cab climate control	X	X	X	X		
55 - Electrical systems	X	X	X	X	X	
56 - Grape harvester shaking						
58 - Attachments/headers			X			
60 - Product feeding			X			

INTRODUCTION

61 - Metering system				X	
62 - Pressing - Bale formation			X		
63 - Chemical applicators				X	
64 - Chopping			X		
66 - Threshing			X		
68 - Tying/Wrapping/Twisting			X		
69 - Bale wagons					
70 - Ejection			X		
71 - Lubrication system	X	X	X	X	X
72 - Separation			X		
73 - Residue handling			X		
74 - Cleaning			X		
75 - Soil preparation/Finishing					
76 - Secondary cleaning / Destemmer					
77 - Seeding				X	
78 - Spraying				X	
79 - Planting				X	
80 - Crop storage / Unloading			X		
82 - Front loader and bucket	X	X			
83 - Telescopic single arm	X	X			
84 - Booms, dippers and buckets	X	X			
86 - Dozer blade and arm	X	X			
88 - Accessories	X	X	X	X	X
89 - Tools	X	X	X	X	X
90 - Platform, cab, bodywork and decals	X	X	X	X	

## Chapters

Each Chapter is identified by a number e.g. Engine - Engine and crankcase - 10.001. The first number is identical to the Section number i.e. Chapter 10.001 is inside Section 10, Engine. The second number is representative of the Chapter contained within the Section.

### CONTENTS

The Chapter Contents lists all the technical data (specifications), functional data (how it works), diagnostic data (fault codes and troubleshooting), and service data (remove, install, adjust, etc.), that have been written in that Chapter for that function or system on the machine.

### Contents

	ENGINE	
	ENGINE - Engine and crankcase – 10.001	
TECHNICAL DATA		
ENGINE - Engine and crankcase - General specification (10.001 - D.40.A.10)		4
FUNCTIONAL DATA		
ENGINE - Engine and crankcase - Dynamic description (10.001 - C.30.A.10)		6
SERVICE		
ENGINE - Engine and crankcase - Remove (10.001 -F.10.A.10)		8
DIAGNOSTIC		
ENGINE - Engine and crankcase - Troubleshooting (10.001 - G.40.A.10)		10

### INDEX

The Chapter Index lists in alphabetical order all the types of information (called information units) that have been written in that Chapter for that function or system on the machine.

### Index

	ENGINE - 10	
	ENGINE	
ENGINE - Engine and crankcase - Dynamic description (10.001 - C.30.A.10)		6
ENGINE - Engine and crankcase - General specification (10.001 - D.40.A.10)		4
ENGINE - Engine and crankcase - Remove (10.001 -F.10.A.10)		8
ENGINE - Engine and crankcase - Troubleshooting (10.001 - G.40.A.10)		10

## Information units and information search

Each chapter is composed of information units. Each information unit has the SAP code shown in parentheses. This indicates the function and type of information in that information unit. Each information unit has a page reference within that Chapter. The information units provide a quick and easy way to find just the right piece of technical information you are looking for.

Example information unit	Engine block cover - Front – Remove (10.102.AP.01 - F.10.A.10)					
Information Unit SAP code	10	102	AK	01	F	10.A.10
SAP code classification	Engine	Pan and covers	Engine block cover	Front	Service data	Remove cover

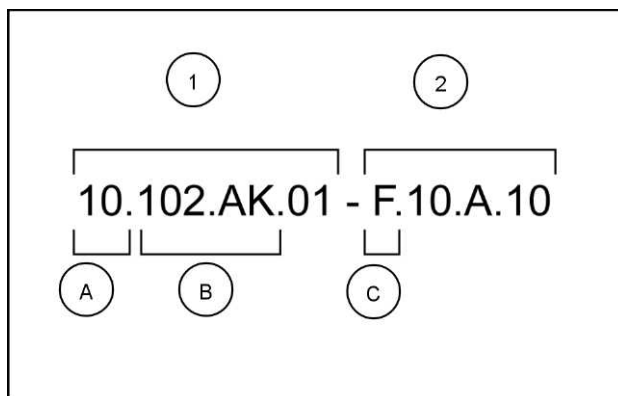

NHIL12GEN0070A 1

Navigate to the correct information unit you are searching for by identifying the function and information type from the SAP code.

- **(1)** Location and **(2)** Information type.
- **(A)** corresponds to the sections of the service manual.  
**(B)** corresponds to the chapters of the service manual. After **(B)** there may be some additional information. In this case it shows “.01”, which represents the “Front” block cover. These options may be front/rear, left/right, hydraulic/mechanical etc.
- **(C)** corresponds to the type of information listed in the chapter contents: Technical Data, Functional Data, Diagnostic, or Service.
- **(A)** and **(B)** are also shown in the page numbering on the page footer.  
THE REST OF THE CODING IS NOT LISTED IN ALPHANUMERIC ORDER IN THIS MANUAL.
- You will find a table of contents at the beginning and end of each section and chapter.  
You will find an alphabetical index at the end of each chapter.
- By referring to **(A)**, **(B)** and **(C)** of the coding, you can follow the contents or index (page numbers) and quickly find the information you are looking for.

## Page header and footer

The page header will contain the following references:

- Section and Chapter description

The page footer will contain the following references:

- Publication number for that Manual.
- Version reference for that publication.
- Publication date
- Section, chapter, and page reference e.g. 10.102 / 9

---

## Safety rules - Ecology and the environment

Soil, air, and water quality is important for all industries and life in general. When legislation does not yet rule the treatment of some of the substances that advanced technology requires, sound judgment should govern the use and disposal of products of a chemical and petrochemical nature.

Familiarize yourself with the relative legislation applicable to your country, and make sure that you understand this legislation. Where no legislation exists, obtain information from suppliers of oils, filters, batteries, fuels, anti-freeze, cleaning agents, etc., with regard to the effect of these substances on man and nature and how to safely store, use, and dispose of these substances.

### Helpful hints

- Avoid the use of cans or other inappropriate pressurized fuel delivery systems to fill tanks. Such delivery systems may cause considerable spillage.
- In general, avoid skin contact with all fuels, oils, acids, solvents, etc. Most of these products contain substances that may be harmful to your health.
- Modern oils contain additives. Do not burn contaminated fuels and or waste oils in ordinary heating systems.
- Avoid spillage when you drain fluids such as used engine coolant mixtures, engine oil, hydraulic fluid, brake fluid, etc. Do not mix drained brake fluids or fuels with lubricants. Store all drained fluids safely until you can dispose of the fluids in a proper way that complies with all local legislation and available resources.
- Do not allow coolant mixtures to get into the soil. Collect and dispose of coolant mixtures properly.
- The air-conditioning system contains gases that should not be released into the atmosphere. Consult an air-conditioning specialist or use a special extractor to recharge the system properly.
- Repair any leaks or defects in the engine cooling system or hydraulic system immediately.
- Do not increase the pressure in a pressurized circuit as this may lead to a component failure.
- Protect hoses during welding. Penetrating weld splatter may burn a hole or weaken hoses, allowing the loss of oils, coolant, etc.

### Battery recycling

Batteries and electric accumulators contain several substances that can have a harmful effect on the environment if the batteries are not properly recycled after use. Improper disposal of batteries can contaminate the soil, groundwater, and waterways. CASE CONSTRUCTION strongly recommends that you return all used batteries to a CASE CONSTRUCTION dealer, who will dispose of the used batteries or recycle the used batteries properly. In some countries, this is a legal requirement.



### Mandatory battery recycling

**NOTE:** The following requirements are mandatory in Brazil.

Batteries are made of lead plates and a sulfuric acid solution. Because batteries contain heavy metals such as lead, CONAMA Resolution 401/2008 requires you to return all used batteries to the battery dealer when you replace any batteries. Do not dispose of batteries in your household garbage.

Points of sale are obliged to:

- Accept the return of your used batteries
- Store the returned batteries in a suitable location
- Send the returned batteries to the battery manufacturer for recycling



---

## Safety rules

### Personal safety





This is the safety alert symbol. It is used to alert you to potential personal injury hazards. Obey all safety messages that follow this symbol to avoid possible death or injury.

Throughout this manual and on machine safety signs, you will find the signal words DANGER, WARNING, and CAUTION followed by special instructions. These precautions are intended for the personal safety of you and those working with you.

Read and understand all the safety messages in this manual before you operate or service the machine.

 DANGER indicates a hazardous situation that, if not avoided, will result in death or serious injury. The color associated with DANGER is RED.

 WARNING indicates a hazardous situation that, if not avoided, could result in death or serious injury. The color associated with WARNING is ORANGE.

 CAUTION indicates a hazardous situation that, if not avoided, could result in minor or moderate injury. The color associated with CAUTION is YELLOW.

### **FAILURE TO FOLLOW DANGER, WARNING, AND CAUTION MESSAGES COULD RESULT IN DEATH OR SERIOUS INJURY.**

### Machine safety

**NOTICE:** Notice indicates a situation that, if not avoided, could result in machine damage or property damage. The color associated with Notice is BLUE.

Throughout this manual you will find the signal word Notice followed by special instructions to prevent machine damage or property damage. The word Notice is used to address practices not related to personal safety.

### Information

**NOTE:** Note indicates additional information that clarifies steps, procedures, or other information in this manual.

Throughout this manual you will find the word Note followed by additional information about a step, procedure, or other information in the manual. The word Note is not intended to address personal safety or property damage.

---

## Basic instructions - Shop and assembly

### Shimming

For each adjustment operation, select adjusting shims and measure the adjusting shims individually using a micrometer, then add up the recorded values. Do not rely on measuring the entire shimming set, which may be incorrect, or the rated value shown on each shim.

### Rotating shaft seals

For correct rotating shaft seal installation, proceed as follows:

1. Before assembly, allow the seal to soak in the oil it will be sealing for at least thirty minutes.
2. Thoroughly clean the shaft and check that the working surface on the shaft is not damaged.
3. Position the sealing lip facing the fluid.

**NOTE:** *With hydrodynamic lips, take into consideration the shaft rotation direction and position the grooves so that they will move the fluid towards the inner side of the seal.*

4. Coat the sealing lip with a thin layer of lubricant (use oil rather than grease). Fill the gap between the sealing lip and the dust lip on double lip seals with grease.
5. Insert the seal in its seat and press down using a flat punch or seal installation tool. Do not tap the seal with a hammer or mallet.
6. While you insert the seal, check that the seal is perpendicular to the seat. When the seal settles, make sure that the seal makes contact with the thrust element, if required.
7. To prevent damage to the seal lip on the shaft, position a protective guard during installation operations.

### O-ring seals

Lubricate the O-ring seals before you insert them in the seats. This will prevent the O-ring seals from overturning and twisting, which would jeopardize sealing efficiency.

### Sealing compounds

Apply a sealing compound on the mating surfaces when specified by the procedure. Before you apply the sealing compound, prepare the surfaces as directed by the product container.

### Spare parts

Only use CNH Original Parts or CASE CONSTRUCTION Original Parts.

Only genuine spare parts guarantee the same quality, duration, and safety as original parts, as they are the same parts that are assembled during standard production. Only CNH Original Parts or CASE CONSTRUCTION Original Parts can offer this guarantee.

When ordering spare parts, always provide the following information:

- Machine model (commercial name) and Product Identification Number (PIN)
- Part number of the ordered part, which can be found in the parts catalog

---

## Protecting the electronic and/or electrical systems during charging and welding

To avoid damage to the electronic and/or electrical systems, always observe the following practices:

1. Never make or break any of the charging circuit connections when the engine is running, including the battery connections.
2. Never short any of the charging components to ground.
3. Always disconnect the ground cable from the battery before arc welding on the machine or on any machine attachment.
  - Position the welder ground clamp as close to the welding area as possible.
  - If you weld in close proximity to a computer module, then you should remove the module from the machine.
  - Never allow welding cables to lie on, near, or across any electrical wiring or electronic component while you weld.
4. Always disconnect the negative cable from the battery when charging the battery in the machine with a battery charger.

**NOTICE:** *If you must weld on the unit, you must disconnect the battery ground cable from the machine battery. The electronic monitoring system and charging system will be damaged if this is not done.*

5. Remove the battery ground cable. Reconnect the cable when you complete welding.

### WARNING

**Battery acid causes burns. Batteries contain sulfuric acid.**

**Avoid contact with skin, eyes or clothing. Antidote (external): Flush with water. Antidote (eyes): flush with water for 15 minutes and seek medical attention immediately. Antidote (internal): Drink large quantities of water or milk. Do not induce vomiting. Seek medical attention immediately. Failure to comply could result in death or serious injury.**

W0111A

## Special tools

The special tools that CASE CONSTRUCTION suggests and illustrate in this manual have been specifically researched and designed for use with CASE CONSTRUCTION machines. The special tools are essential for reliable repair operations. The special tools are accurately built and rigorously tested to offer efficient and long-lasting operation.

By using these tools, repair personnel will benefit from:

- Operating in optimal technical conditions
- Obtaining the best results
- Saving time and effort
- Working in safe conditions

## Torque - Minimum tightening torques for normal assembly

### METRIC NON-FLANGED HARDWARE

NOM. SIZE	CLASS 8.8 BOLT and CLASS 8 NUT		CLASS 10.9 BOLT and CLASS 10 NUT		LOCKNUT CL.8 W/CL8.8 BOLT	LOCKNUT CL.10 W/CL10.9 BOLT
	UNPLATED	PLATED W/ZnCr	UNPLATED	PLATED W/ZnCr		
M4	2.2 N·m (19 lb in)	2.9 N·m (26 lb in)	3.2 N·m (28 lb in)	4.2 N·m (37 lb in)	2 N·m (18 lb in)	2.9 N·m (26 lb in)
M5	4.5 N·m (40 lb in)	5.9 N·m (52 lb in)	6.4 N·m (57 lb in)	8.5 N·m (75 lb in)	4 N·m (36 lb in)	5.8 N·m (51 lb in)
M6	7.5 N·m (66 lb in)	10 N·m (89 lb in)	11 N·m (96 lb in)	15 N·m (128 lb in)	6.8 N·m (60 lb in)	10 N·m (89 lb in)
M8	18 N·m (163 lb in)	25 N·m (217 lb in)	26 N·m (234 lb in)	35 N·m (311 lb in)	17 N·m (151 lb in)	24 N·m (212 lb in)
M10	37 N·m (27 lb ft)	49 N·m (36 lb ft)	52 N·m (38 lb ft)	70 N·m (51 lb ft)	33 N·m (25 lb ft)	48 N·m (35 lb ft)
M12	64 N·m (47 lb ft)	85 N·m (63 lb ft)	91 N·m (67 lb ft)	121 N·m (90 lb ft)	58 N·m (43 lb ft)	83 N·m (61 lb ft)
M16	158 N·m (116 lb ft)	210 N·m (155 lb ft)	225 N·m (166 lb ft)	301 N·m (222 lb ft)	143 N·m (106 lb ft)	205 N·m (151 lb ft)
M20	319 N·m (235 lb ft)	425 N·m (313 lb ft)	440 N·m (325 lb ft)	587 N·m (433 lb ft)	290 N·m (214 lb ft)	400 N·m (295 lb ft)
M24	551 N·m (410 lb ft)	735 N·m (500 lb ft)	762 N·m (560 lb ft)	1016 N·m (750 lb ft)	501 N·m (370 lb ft)	693 N·m (510 lb ft)

**NOTE:** M4 through M8 hardware torque specifications are shown in pound-inches. M10 through M24 hardware torque specifications are shown in pound-feet.

**METRIC FLANGED HARDWARE**

NOM. SIZE	CLASS 8.8 BOLT and CLASS 8 NUT		CLASS 10.9 BOLT and CLASS 10 NUT		LOCKNUT CL.8 W/CL8.8 BOLT	LOCKNUT CL.10 W/CL10.9 BOLT
	UNPLATED	PLATED W/ZnCr	UNPLATED	PLATED W/ZnCr		
M4	2.4 N·m (21 lb in)	3.2 N·m (28 lb in)	3.5 N·m (31 lb in)	4.6 N·m (41 lb in)	2.2 N·m (19 lb in)	3.1 N·m (27 lb in)
M5	4.9 N·m (43 lb in)	6.5 N·m (58 lb in)	7.0 N·m (62 lb in)	9.4 N·m (83 lb in)	4.4 N·m (39 lb in)	6.4 N·m (57 lb in)
M6	8.3 N·m (73 lb in)	11 N·m (96 lb in)	12 N·m (105 lb in)	16 N·m (141 lb in)	7.5 N·m (66 lb in)	11 N·m (96 lb in)
M8	20 N·m (179 lb in)	27 N·m (240 lb in)	29 N·m (257 lb in)	39 N·m (343 lb in)	18 N·m (163 lb in)	27 N·m (240 lb in)
M10	40 N·m (30 lb ft)	54 N·m (40 lb ft)	57 N·m (42 lb ft)	77 N·m (56 lb ft)	37 N·m (27 lb ft)	53 N·m (39 lb ft)
M12	70 N·m (52 lb ft)	93 N·m (69 lb ft)	100 N·m (74 lb ft)	134 N·m (98 lb ft)	63 N·m (47 lb ft)	91 N·m (67 lb ft)
M16	174 N·m (128 lb ft)	231 N·m (171 lb ft)	248 N·m (183 lb ft)	331 N·m (244 lb ft)	158 N·m (116 lb ft)	226 N·m (167 lb ft)
M20	350 N·m (259 lb ft)	467 N·m (345 lb ft)	484 N·m (357 lb ft)	645 N·m (476 lb ft)	318 N·m (235 lb ft)	440 N·m (325 lb ft)
M24	607 N·m (447 lb ft)	809 N·m (597 lb ft)	838 N·m (618 lb ft)	1118 N·m (824 lb ft)	552 N·m (407 lb ft)	

**IDENTIFICATION**

**Metric Hex head and carriage bolts, classes 5.6 and up**

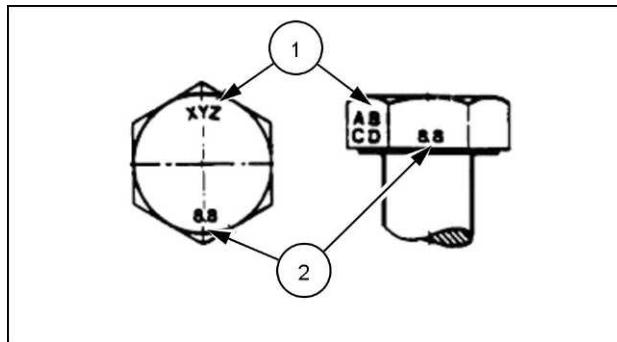

20083680 1

1. Manufacturer's Identification
2. Property Class

**Metric Hex nuts and locknuts, classes 05 and up**

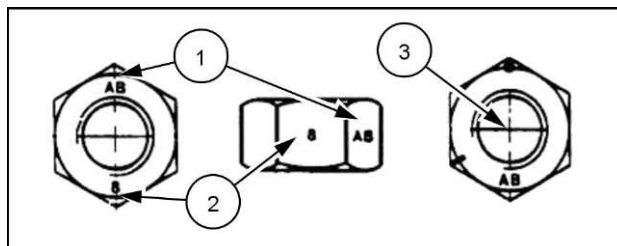

20083681 2

1. Manufacturer's Identification
2. Property Class
3. Clock Marking of Property Class and Manufacturer's Identification (Optional), i.e. marks **60** ° apart indicate Class 10 properties, and marks **120** ° apart indicate Class 8.

**INCH NON-FLANGED HARDWARE**

NOMINAL SIZE	SAE GRADE 5 BOLT and NUT		SAE GRADE 8 BOLT and NUT		LOCKNUT GrB W/ Gr5 BOLT	LOCKNUT GrC W/ Gr8 BOLT
	UN-PLATED or PLATED SILVER	PLATED W/ZnCr GOLD	UN-PLATED or PLATED SILVER	PLATED W/ZnCr GOLD		
1/4	8 N·m (71 lb in)	11 N·m (97 lb in)	12 N·m (106 lb in)	16 N·m (142 lb in)	8.5 N·m (75 lb in)	12.2 N·m (109 lb in)
5/16	17 N·m (150 lb in)	23 N·m (204 lb in)	24 N·m (212 lb in)	32 N·m (283 lb in)	17.5 N·m (155 lb in)	25 N·m (220 lb in)
3/8	30 N·m (22 lb ft)	40 N·m (30 lb ft)	43 N·m (31 lb ft)	57 N·m (42 lb ft)	31 N·m (23 lb ft)	44 N·m (33 lb ft)
7/16	48 N·m (36 lb ft)	65 N·m (48 lb ft)	68 N·m (50 lb ft)	91 N·m (67 lb ft)	50 N·m (37 lb ft)	71 N·m (53 lb ft)
1/2	74 N·m (54 lb ft)	98 N·m (73 lb ft)	104 N·m (77 lb ft)	139 N·m (103 lb ft)	76 N·m (56 lb ft)	108 N·m (80 lb ft)
9/16	107 N·m (79 lb ft)	142 N·m (105 lb ft)	150 N·m (111 lb ft)	201 N·m (148 lb ft)	111 N·m (82 lb ft)	156 N·m (115 lb ft)
5/8	147 N·m (108 lb ft)	196 N·m (145 lb ft)	208 N·m (153 lb ft)	277 N·m (204 lb ft)	153 N·m (113 lb ft)	215 N·m (159 lb ft)
3/4	261 N·m (193 lb ft)	348 N·m (257 lb ft)	369 N·m (272 lb ft)	491 N·m (362 lb ft)	271 N·m (200 lb ft)	383 N·m (282 lb ft)
7/8	420 N·m (310 lb ft)	561 N·m (413 lb ft)	594 N·m (438 lb ft)	791 N·m (584 lb ft)	437 N·m (323 lb ft)	617 N·m (455 lb ft)
1	630 N·m (465 lb ft)	841 N·m (620 lb ft)	890 N·m (656 lb ft)	1187 N·m (875 lb ft)	654 N·m (483 lb ft)	924 N·m (681 lb ft)

**NOTE:** For Imperial Units, *1/4 in* and *5/16 in* hardware torque specifications are shown in pound-inches. *3/8 in* through *1 in* hardware torque specifications are shown in pound-feet.

**INCH FLANGED HARDWARE**

NOM- INAL SIZE	SAE GRADE 5 BOLT and NUT		SAE GRADE 8 BOLT and NUT		LOCKNUT GrF W/ Gr5 BOLT	LOCKNUT GrG W/ Gr8 BOLT
	UNPLATED or PLATED SILVER	PLATED W/ZnCr GOLD	UNPLATED or PLATED SILVER	PLATED W/ZnCr GOLD		
1/4	9 N·m (80 lb in)	12 N·m (106 lb in)	13 N·m (115 lb in)	17 N·m (150 lb in)	8 N·m (71 lb in)	12 N·m (106 lb in)
5/16	19 N·m (168 lb in)	25 N·m (221 lb in)	26 N·m (230 lb in)	35 N·m (310 lb in)	17 N·m (150 lb in)	24 N·m (212 lb in)
3/8	33 N·m (25 lb ft)	44 N·m (33 lb ft)	47 N·m (35 lb ft)	63 N·m (46 lb ft)	30 N·m (22 lb ft)	43 N·m (32 lb ft)
7/16	53 N·m (39 lb ft)	71 N·m (52 lb ft)	75 N·m (55 lb ft)	100 N·m (74 lb ft)	48 N·m (35 lb ft)	68 N·m (50 lb ft)
1/2	81 N·m (60 lb ft)	108 N·m (80 lb ft)	115 N·m (85 lb ft)	153 N·m (113 lb ft)	74 N·m (55 lb ft)	104 N·m (77 lb ft)
9/16	117 N·m (86 lb ft)	156 N·m (115 lb ft)	165 N·m (122 lb ft)	221 N·m (163 lb ft)	106 N·m (78 lb ft)	157 N·m (116 lb ft)
5/8	162 N·m (119 lb ft)	216 N·m (159 lb ft)	228 N·m (168 lb ft)	304 N·m (225 lb ft)	147 N·m (108 lb ft)	207 N·m (153 lb ft)
3/4	287 N·m (212 lb ft)	383 N·m (282 lb ft)	405 N·m (299 lb ft)	541 N·m (399 lb ft)	261 N·m (193 lb ft)	369 N·m (272 lb ft)
7/8	462 N·m (341 lb ft)	617 N·m (455 lb ft)	653 N·m (482 lb ft)	871 N·m (642 lb ft)	421 N·m (311 lb ft)	594 N·m (438 lb ft)
1	693 N·m (512 lb ft)	925 N·m (682 lb ft)	979 N·m (722 lb ft)	1305 N·m (963 lb ft)	631 N·m (465 lb ft)	890 N·m (656 lb ft)

**IDENTIFICATION**

**Inch Bolts and free-spinning nuts**

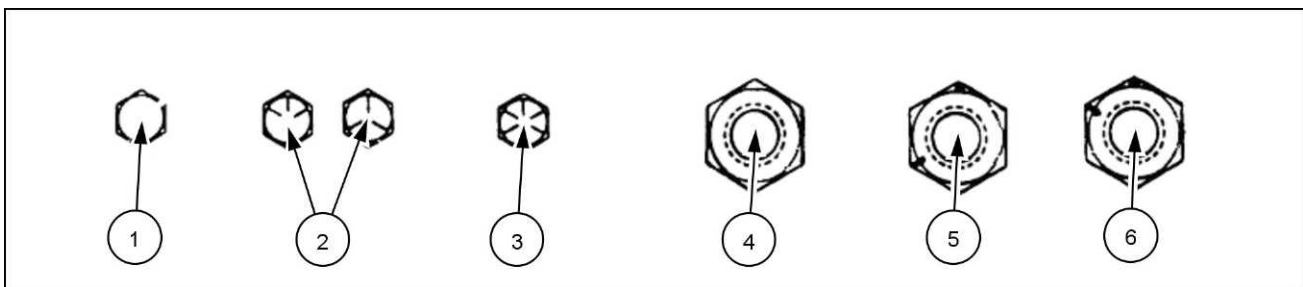

20083682 3

**Grade Marking Examples**

SAE Grade Identification			
1	Grade 2 - No Marks	4	Grade 2 Nut - No Marks
2	Grade 5 - Three Marks	5	Grade 5 Nut - Marks 120 ° Apart
3	Grade 8 - Five Marks	6	Grade 8 Nut - Marks 60 ° Apart

**Inch Lock Nuts, All Metal (Three optional methods)**

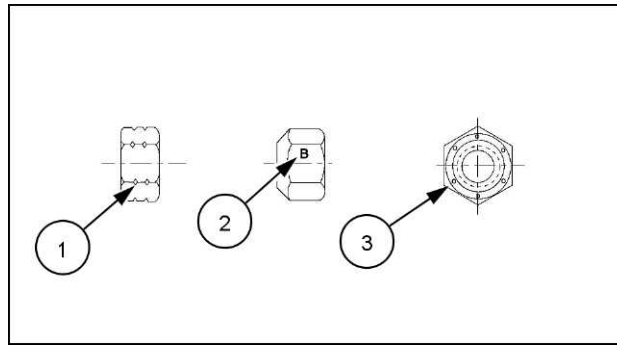

20090268 4

**Grade Identification**

Grade	Corner Marking Method (1)	Flats Marking Method (2)	Clock Marking Method (3)
Grade A	No Notches	No Mark	No Marks
Grade B	One Circumferential Notch	Letter B	Three Marks
Grade C	Two Circumferential Notches	Letter C	Six Marks



## Torque - Standard torque data for hydraulics

### Installation of adjustable fittings in straight thread O-ring bosses

1. Lubricate the O-ring by coating it with a light oil or petroleum. Install the O-ring in the groove adjacent to the metal backup washer which is assembled at the extreme end of the groove (4).
2. Install the fitting into the SAE straight thread boss until the metal backup washer contacts the face of the boss (5).

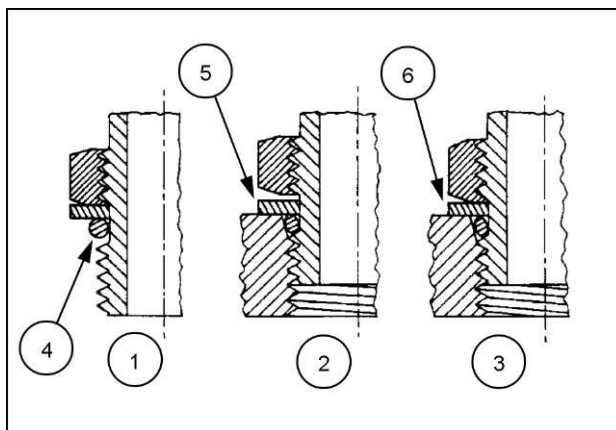

23085659 1

**NOTE:** Do not over tighten and distort the metal backup washer.

3. Position the fitting by turning out (counterclockwise) up to a maximum of one turn. Holding the pad of the fitting with a wrench, tighten the locknut and washer against the face of the boss (6).

### Standard torque data for hydraulic tubes and fittings

Tube nuts for 37° flared fittings				O-ring boss plugs adjustable fitting locknuts, swivel JIC-37° seats
Size	Tubing OD	Thread size	Torque	Torque
4	6.4 mm (1/4 in)	7/16-20	12 - 16 N·m (9 - 12 lb ft)	8 - 14 N·m (6 - 10 lb ft)
5	7.9 mm (5/16 in)	1/2-20	16 - 20 N·m (12 - 15 lb ft)	14 - 20 N·m (10 - 15 lb ft)
6	9.5 mm (3/8 in)	9/16-18	29 - 33 N·m (21 - 24 lb ft)	20 - 27 N·m (15 - 20 lb ft)
8	12.7 mm (1/2 in)	3/4-16	47 - 54 N·m (35 - 40 lb ft)	34 - 41 N·m (25 - 30 lb ft)
10	15.9 mm (5/8 in)	7/8-14	72 - 79 N·m (53 - 58 lb ft)	47 - 54 N·m (35 - 40 lb ft)
12	19.1 mm (3/4 in)	1-1/16-12	104 - 111 N·m (77 - 82 lb ft)	81 - 95 N·m (60 - 70 lb ft)
14	22.2 mm (7/8 in)	1-3/16-12	122 - 136 N·m (90 - 100 lb ft)	95 - 109 N·m (70 - 80 lb ft)
16	25.4 mm (1 in)	1-5/16-12	149 - 163 N·m (110 - 120 lb ft)	108 - 122 N·m (80 - 90 lb ft)
20	31.8 mm (1-1/4 in)	1-5/8-12	190 - 204 N·m (140 - 150 lb ft)	129 - 158 N·m (95 - 115 lb ft)
24	38.1 mm (1-1/2 in)	1-7/8-12	217 - 237 N·m (160 - 175 lb ft)	163 - 190 N·m (120 - 140 lb ft)
32	50.8 mm (2 in)	2-1/2-12	305 - 325 N·m (225 - 240 lb ft)	339 - 407 N·m (250 - 300 lb ft)

These torques are not recommended for tubes of 12.7 mm (1/2 in) OD and larger with wall thickness of 0.889 mm (0.035 in) or less. The torque is specified for 0.889 mm (0.035 in) wall tubes on each application individually.

Before installing and torquing 37° flared fittings, clean the face of the flare and threads with a clean solvent or Loctite cleaner and apply hydraulic sealant **LOCTITE® 569™** to the 37° flare and the threads.

Install fitting and torque to specified torque, loosen fitting and retorque to specifications.

**Pipe thread fitting torque**

Before installing and tightening pipe fittings, clean the threads with a clean solvent or Loctite cleaner and apply sealant **LOCTITE® 567™ PST PIPE SEALANT** for all fittings including stainless steel or **LOCTITE® 565™ PST** for most metal fittings. For high filtration/zero contamination systems use **LOCTITE® 545™**.

Thread size	Torque (maximum)
1/8-27	<b>13 N·m (10 lb ft)</b>
1/4-18	<b>16 N·m (12 lb ft)</b>
3/8-18	<b>22 N·m (16 lb ft)</b>
1/2-14	<b>41 N·m (30 lb ft)</b>
3/4-14	<b>54 N·m (40 lb ft)</b>

**Installation of ORFS (O-Ring Flat Seal fittings)**

When installing ORFS fittings thoroughly clean both flat surfaces of the fittings **(1)** and lubricate the O-ring **(2)** with light oil. Make sure both surfaces are aligned properly. Torque the fitting to specified torque listed throughout the repair manual.

**NOTICE:** *If the fitting surfaces are not properly cleaned, the O-ring will not seal properly. If the fitting surfaces are not properly aligned, the fittings may be damaged and will not seal properly.*

**NOTICE:** *Always use genuine factory replacement oils and filters to ensure proper lubrication and filtration of engine and hydraulic system oils.*

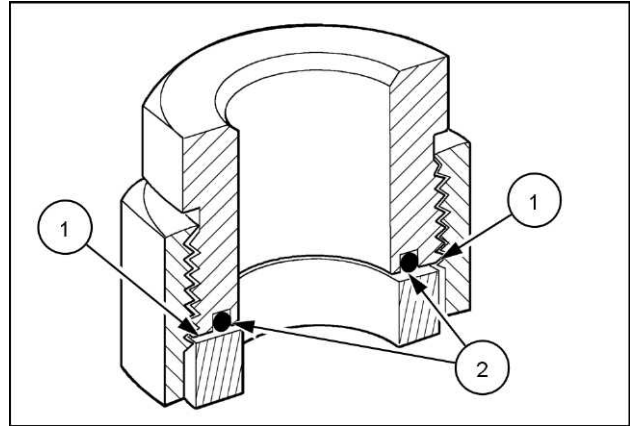

50011183 2

The use of proper oils, grease, and keeping the hydraulic system clean will extend machine and component life.





# **SERVICE MANUAL**

**Engine**

**1650L XLT PAT**

# Contents

---

## Engine - 10

[10.001] Engine and crankcase .....	10.1
[10.400] Engine cooling system .....	10.2
[10.310] Aftercooler.....	10.3
[10.304] Engine lubrication system.....	10.4



## **Engine - 10**

### **Engine and crankcase - 001**

**1650L XLT PAT**

# Contents

---

## Engine - 10

### Engine and crankcase - 001

#### TECHNICAL DATA

##### Engine

Torque (*) .....	3
Torque (*) .....	4
Special tools (*) .....	6
Special tools (*) .....	6
General specification (*) .....	6
General specification (*) .....	8

#### SERVICE

##### Engine

Remove .....	12
Disassemble (*) .....	17
Assemble (*) .....	29
Install .....	31

(\*) See content for specific models

## Engine - Torque

1650L	LA
Engine mounting bolts	<b>205 - 230 N·m</b> <b>(151 - 170 lb ft)</b>
Engine mount mounting bolts	<b>118 - 133 N·m</b> <b>(87 - 98 lb ft)</b>
Bolts for mounting the drive shaft to the engine flywheel	<b>335.0 - 375.0 N·m</b> <b>(247.1 - 276.6 lb ft)</b>
Radiator mounting bolts	<b>68 - 82 N·m</b> <b>(50 - 60 lb ft)</b>
Clamps for fixing the radiator hose and the after cooler	<b>11 - 12 N·m</b> <b>(97 - 106 lb in)</b>
Clamps for fixing the hose between the after cooler and the turbo	<b>3.4 - 4.5 N·m</b> <b>(30 - 40 lb in)</b>
Fan mounting bolts	<b>26 - 33 N·m</b> <b>(19 - 24 lb ft)</b>
Bolts for mounting the drive shaft on the flywheel	<b>335 - 375 N·m</b> <b>(247 - 277 lb ft)</b>
Brush shield mounting bolt	<b>570 - 730 N·m</b> <b>(420 - 538 lb ft)</b>



## Engine - Torque

1650L	LA
Poppet mounting bolts	
First phase	
Screws <b>M12 x 1.75 x 70</b>	<b>45 - 55 N·m (33.2 - 40.6 lb ft)</b>
Screws <b>M12 x 1.75 x 140</b>	<b>35 - 45 N·m (25.8 - 33.2 lb ft)</b>
Bolts <b>M12 x 1.75 x 180</b> (pre-lubricated with oil)	<b>65 - 75 N·m (47.9 - 55.3 lb ft)</b>
Second phase (additional tightening)	<b>90 °</b>
Third phase (additional torque only for bolts that are <b>140 mm</b> and <b>180 mm</b> long)	<b>90 °</b>
Main crankshaft journals	
First phase (pre-lubricate with oil)	<b>44 - 56 N·m (32.5 - 41.3 lb ft)</b>
Second phase	<b>74 - 86 N·m (54.6 - 63.4 lb ft)</b>
Third phase (additional tightening)	<b>85 - 95 °</b>
Link conrod cover fixing bolts	
First phase (pre-lubricate with oil)	<b>55 - 65 N·m (40.6 - 47.9 lb ft)</b>
Second phase (additional tightening)	<b>55 - 65 °</b>
Engine flywheel fixing bolts	
First phase	<b>26 - 34 N·m (19.2 - 25.1 lb ft)</b>
Second phase (additional tightening)	<b>55 - 65 °</b>
Fixing nut of the injector power connector	<b>45 - 50 N·m (33.2 - 36.9 lb ft)</b>
Crankcase	<b>20 - 28 N·m (14.8 - 20.7 lb ft)</b>
Fuel filter	Contact + 3/4 turn
Mounting bolts for the injection pump cover	<b>20 - 30 N·m (14.8 - 22.1 lb ft)</b>
Mounting bolts for the valve mechanism cover and housing	<b>20 - 28 N·m (14.8 - 20.7 lb ft)</b>
Intake manifold fixing bolts	<b>20 - 28 N·m (14.8 - 20.7 lb ft)</b>
Fuel pump mounting bolts	<b>20 - 30 N·m (14.8 - 22.1 lb ft)</b>
Exhaust manifold mounting bolts	<b>48 - 58 N·m (35.4 - 42.8 lb ft)</b>
Valve cover fixing nuts	<b>20 - 28 N·m (14.8 - 20.7 lb ft)</b>
Mounting bolts for the rocker arms support	<b>31 - 41 N·m (22.9 - 30.2 lb ft)</b>
Rocker arms adjustment nut	<b>20 - 28 N·m (14.8 - 20.7 lb ft)</b>
Camshaft pulley mounting bolts	
First phase	<b>45 - 55 N·m (33.2 - 40.6 lb ft)</b>
Second phase (additional tightening)	<b>85 - 95 °</b>
Mounting bolts for the camshaft shoulder plate	<b>20 - 28 N·m (14.8 - 20.7 lb ft)</b>
Fan bracket mounting bolts	<b>20 - 30 N·m (14.8 - 22.1 lb ft)</b>
Injection pump fixing bolts	<b>7 - 17 N·m (5.2 - 12.5 lb ft)</b>
Fan pulley mounting bolts	<b>37 - 49 N·m (27.3 - 36.1 lb ft)</b>
Turbocharger mounting bolts	<b>20 - 30 N·m (14.8 - 22.1 lb ft)</b>
Starter motor mounting bolts	<b>37 - 49 N·m (27.3 - 36.1 lb ft)</b>
Alternator mounting bolts	<b>37 - 49 N·m (27.3 - 36.1 lb ft)</b>
Water pump mounting bolts	<b>20 - 28 N·m (14.8 - 20.7 lb ft)</b>
Oil filter	Contact + 3/4 turn
Belt tensioner mounting bolt	<b>37 - 49 N·m (27.3 - 36.1 lb ft)</b>
Heat exchanger of control unit EDC7UC31	
Screw <b>M6</b>	<b>8 - 12 N·m (5.9 - 8.9 lb ft)</b>
Screw <b>M8</b>	<b>20 - 28 N·m (14.8 - 20.7 lb ft)</b>
First stage	<b>7 - 9 N·m (5.2 - 6.6 lb ft)</b>
Second stage	<b>20 - 28 N·m (14.8 - 20.7 lb ft)</b>
Bolts that secure the oil spray nozzles on the cylinder	<b>12 - 18 N·m (8.9 - 13.3 lb ft)</b>
"Common Rail" mounting bolts	<b>20 - 28 N·m (14.8 - 20.7 lb ft)</b>
Intake air pressure and temperature sensor	<b>5 - 7 N·m (3.7 - 5.2 lb ft)</b>
Bolt for the engine oil level sensor	<b>10 - 14 N·m (7.4 - 10.3 lb ft)</b>
Bolts that secure the turbocharger to the exhaust manifold	<b>37 - 49 N·m (27.3 - 36.1 lb ft)</b>

Engine - Engine and crankcase

Mounting bolt <b>M6</b> of the electrical wiring harness duct	<b>8 - 12 N·m (5.9 - 8.9 lb ft)</b>
Bolt of the electrical wiring harness bracket for the injector	<b>20 - 28 N·m (14.8 - 20.7 lb ft)</b>
Fuel filter bracket	
Screw <b>M12</b>	<b>69 - 85 N·m (50.9 - 62.7 lb ft)</b>
Screw <b>M8</b>	<b>20 - 28 N·m (14.8 - 20.7 lb ft)</b>
Engine flywheel case	
Screw <b>M10</b>	<b>75 - 95 N·m (55.3 - 70.1 lb ft)</b>
Screw <b>M12</b>	<b>44 - 55 N·m (32.5 - 40.6 lb ft)</b>
Camshaft sensor mounting bolt	<b>6 - 10 N·m (4.4 - 7.4 lb ft)</b>
Crankshaft sensor mounting bolt	<b>6 - 10 N·m (4.4 - 7.4 lb ft)</b>
Mounting bolt of the engine coolant temperature sensor	<b>17 - 23 N·m (12.5 - 17.0 lb ft)</b>
Mounting bolt of the oil temperature and pressure sensor	<b>5 - 7 N·m (3.7 - 5.2 lb ft)</b>
Fuel pressure sensor mounting bolt	<b>30 - 40 N·m (22.1 - 29.5 lb ft)</b>
Fuel temperature sensor mounting bolt	<b>17 - 23 N·m (12.5 - 17.0 lb ft)</b>

## Engine - Special tools

1650L | LA

<b>380000158</b>	<b>1 - 6 N·m</b> torque dynamometric screwdriver for calibration of the jam nut of the injector solenoid valve connector (Common Rail).
<b>380000665</b>	Tool for removal of the front crankshaft seal.
<b>380000663</b>	Tool for removal of the rear crankshaft seal.
<b>380000671</b>	Tool for removal of the injectors.
<b>380000666</b>	Coupler for installation of the front crankshaft seal.
<b>380000664</b>	Coupler for installation of the rear crankshaft seal.
<b>380000988</b>	Tool to rotate the engine flywheel.
<b>380001099</b>	Tool for removal of the injectors.

## Engine - Special tools

1650L | LA

### Diagnostic tool for CNH engines

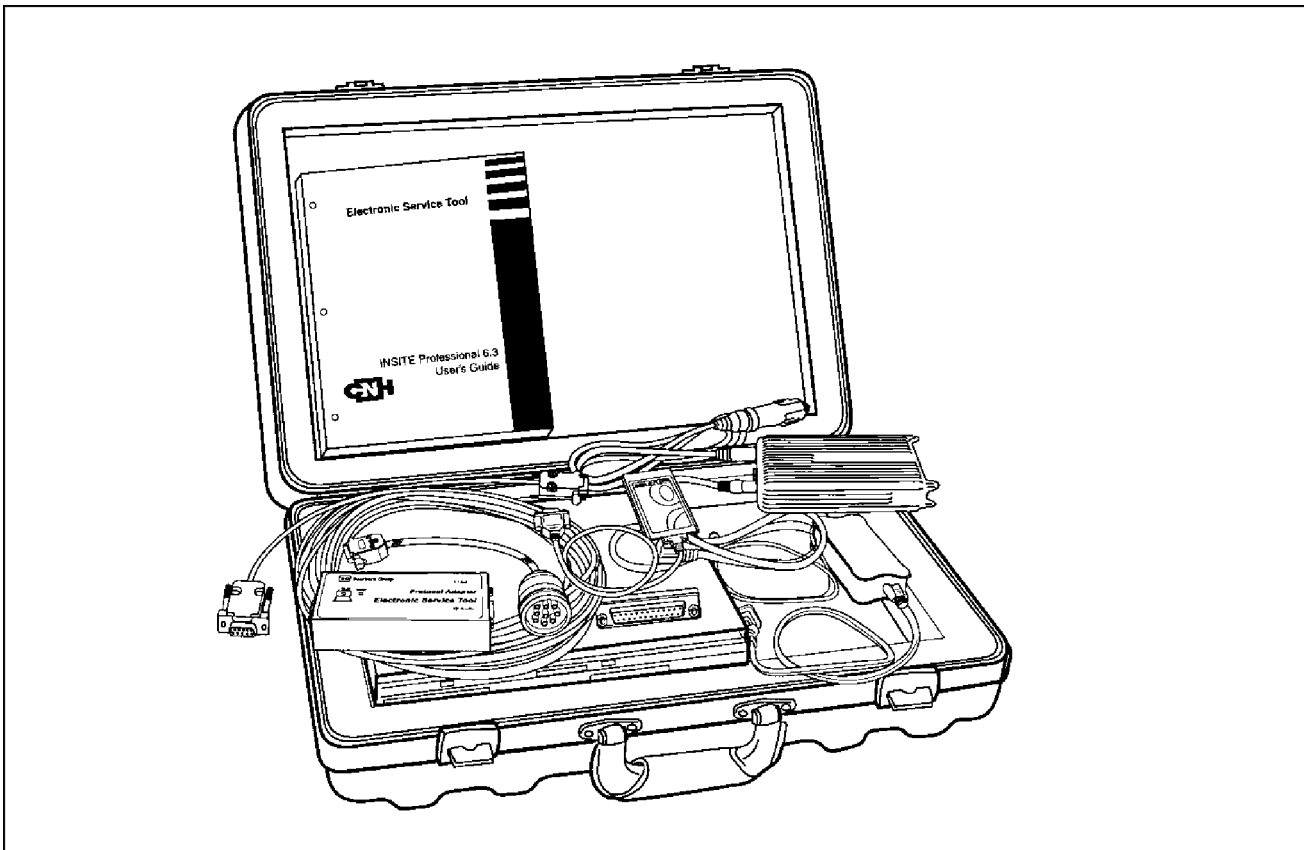

LAIL11CD1694F0A 1

The Electronic Service Tool (EST) system allows you to perform diagnostics on the machine. You can check the parameters of the electronics (control units, sensors, etc.), flow rates, pressures, and temperatures. The system can also read fault codes to help diagnose the failure modes of the engine.

## Engine - General specification

1650L | LA

**General engine characteristics**

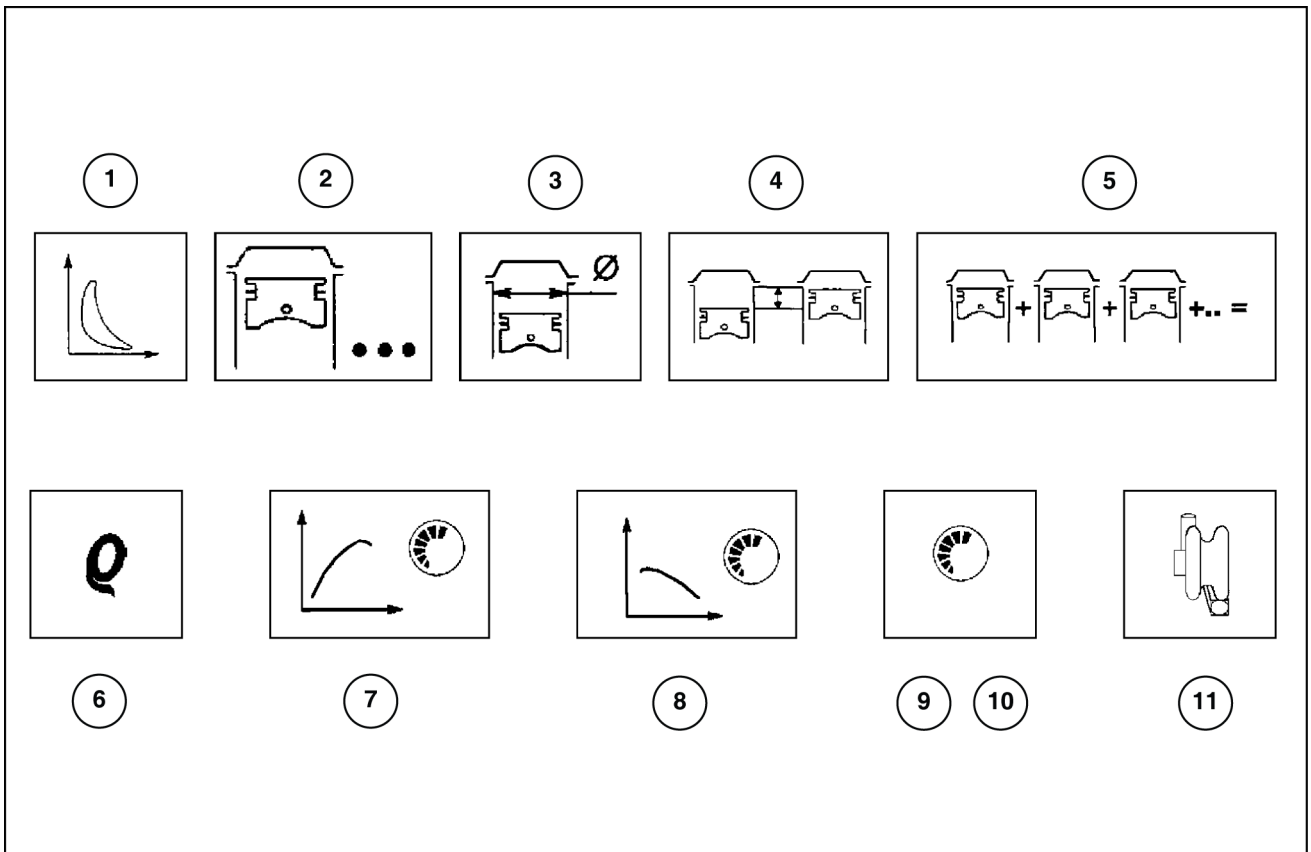

LAIL11CD1517F0A 1

1	Loop	4-stroke diesel fuel engine
	Air	T.A.A. (Turbocharged with air intake air cooler)
	Injection	Direct
2	Number of rolls	6 In-line
3	Roll diameter	<b>104 mm (4 in)</b>
4	Stroke	<b>132 mm (5 in)</b>
5	Total cylinder capacity	<b>6728 cm<sup>3</sup> (411 in<sup>3</sup>)</b>
6	Compression ratio	?????
7	Maximum nominal power (net horsepower at the engine flywheel ISO 14396)	<b>97.0 kW (131.9 Hp) @ 2200 RPM</b>
8	Maximum Torque	<b>607.0 N·m (447.7 lb ft) @ 1400 RPM</b>
9	Idle speed with no load	<b>700 RPM</b>
10	Peak rpm with no load	?????
11	Turbocharging (turbocharger type)	With air intake air cooler HOLSET HX35

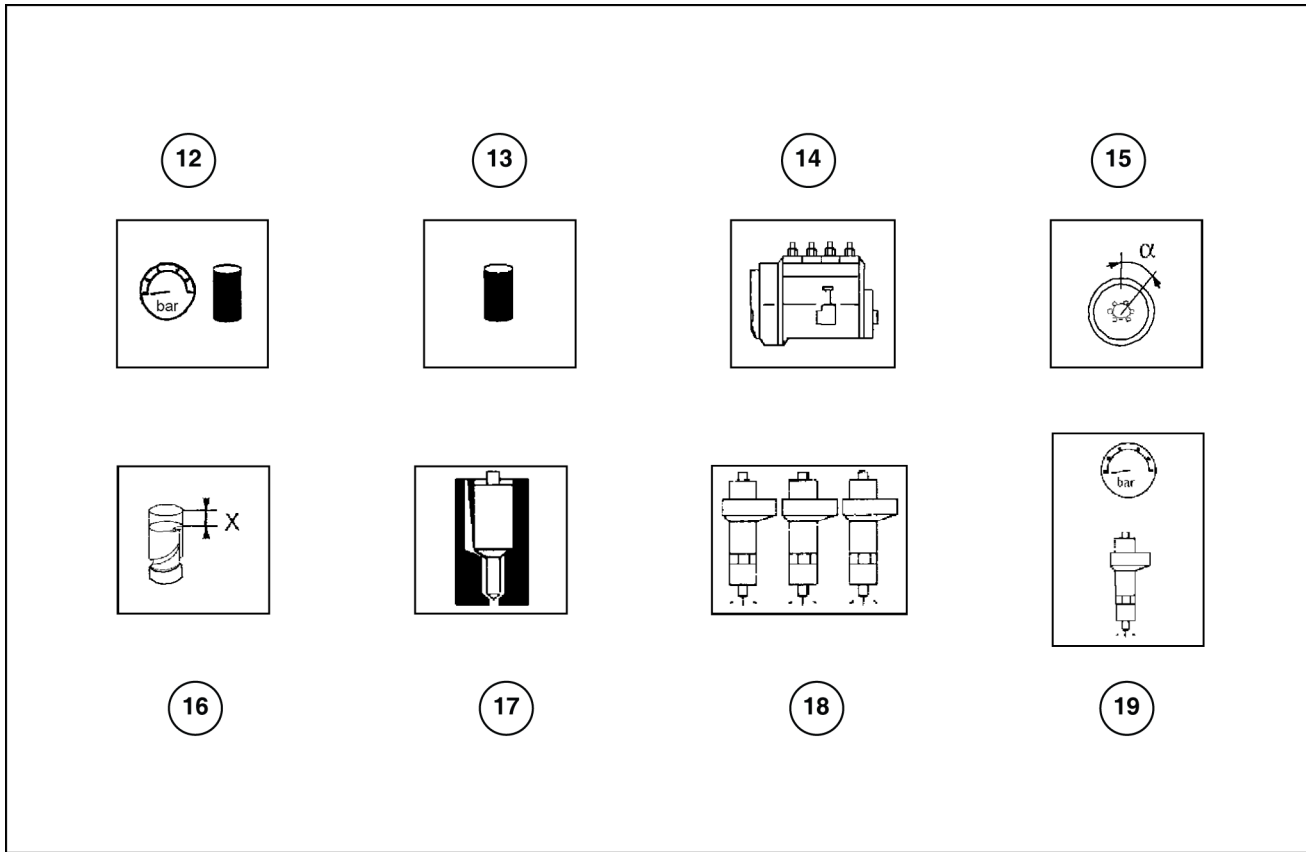

LAIL11CD1518F0A 2

12	Lubrication	Forced through gear pump. Oil control valve PSI
	Oil pressure with hot engine: at idle speed RPM	<b>1.2 bar (17 psi)</b>
	Oil pressure with hot engine: at maximum RPM	<b>3.8 bar (55 psi)</b>
13	Cooling	Recommended
	Water pump drive	Belt
	Temperature at which the thermostat valve starts to open	<b>83 - 98 °C (181 - 208 °F)</b>
14	Oil capacity in first filling	No Information Available
	Engine sump oil capacity	No Information Available
	Engine sump + filter oil capacity	<b>19 l (20 US qt)</b>
15	Bosch high pressure supply pump	High Pressure "Common rail" System
16	Pump setting	No Information Available
17	Start of distribution	No Information Available
18	Injector type	CRIN 2
19	Injection order	1 - 5 - 3 - 6 - 2 - 4

## Engine - General specification

1650L	LA
-------	----

**Components of the crankshaft and cylinder assembly mechanism**

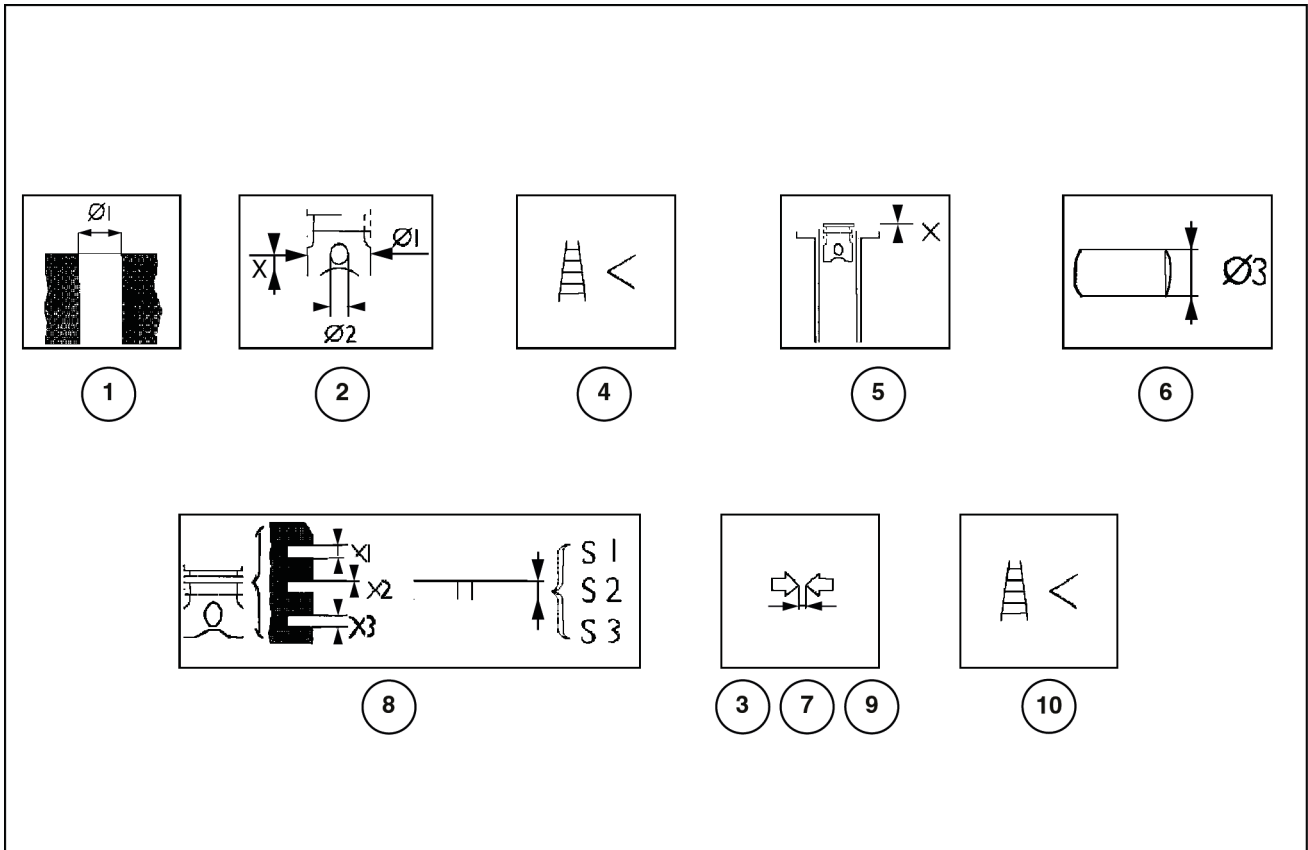

LAIL11CD1588F0A 1

1.	Cylinder hole diameter	<b>104.000 - 104.024 mm (4.0945 - 4.0954 in)</b>
2.	Plungers:	Supplied as spares
	Measurement dimension	X = <b>49.5 mm (1.9488 in)</b>
	Outside Diameter	<b>Ø1 = 103.759 - 103.777 mm (4.0850 - 4.0857 in)</b>
	Pin seat	<b>Ø2 = 38.010 - 38.016 mm (1.4965 - 1.4967 in)</b>
3.	Plunger – cylinder liners	<b>0.235 - 0.273 mm (0.0093 - 0.0107 in)</b>
4.	Plunger diameter	<b>Ø = 0.4 mm (0.0157 in)</b>
5.	Protrusion of the plungers from the engine block	No information available
6.	Plunger pin	<b>Ø3 = 37.994 - 38.000 mm (1.4958 - 1.4961 in)</b>
7.	Plunger pin – Plunger seat	<b>0.01 - 0.022 mm (0.0004 - 0.0009 in)</b>
8.	Plunger ring grooves [Measured at Ø of <b>101 mm (3.9764 in)</b> ]	X1 = <b>2.705 - 2.735 mm (0.1065 - 0.1077 in)</b>
		X2 = <b>2.420 - 2.440 mm (0.0953 - 0.0961 in)</b>
		X3 = <b>4.03 - 4.05 mm (0.1587 - 0.1594 in)</b>
	Plunger rings [Measured <b>1.5 mm (0.0591 in)</b> away from outer Ø]	S1 = <b>2.560 - 2.605 mm (0.1008 - 0.1026 in)</b>
S2 = <b>2.350 - 2.380 mm (0.0925 - 0.0937 in)</b>		
S3 = <b>3.977 - 3.990 mm (0.1566 - 0.1571 in)</b>		
9.	Plunger rings – Slots	1 = <b>0.100 - 0.175 mm (0.0039 - 0.0069 in)</b>
		2 = <b>0.04 - 0.09 mm (0.0016 - 0.0035 in)</b>
		3 = <b>0.04 - 0.083 mm (0.0016 - 0.0033 in)</b>
10.	Plunger rings	<b>0.4 mm (0.0157 in)</b>

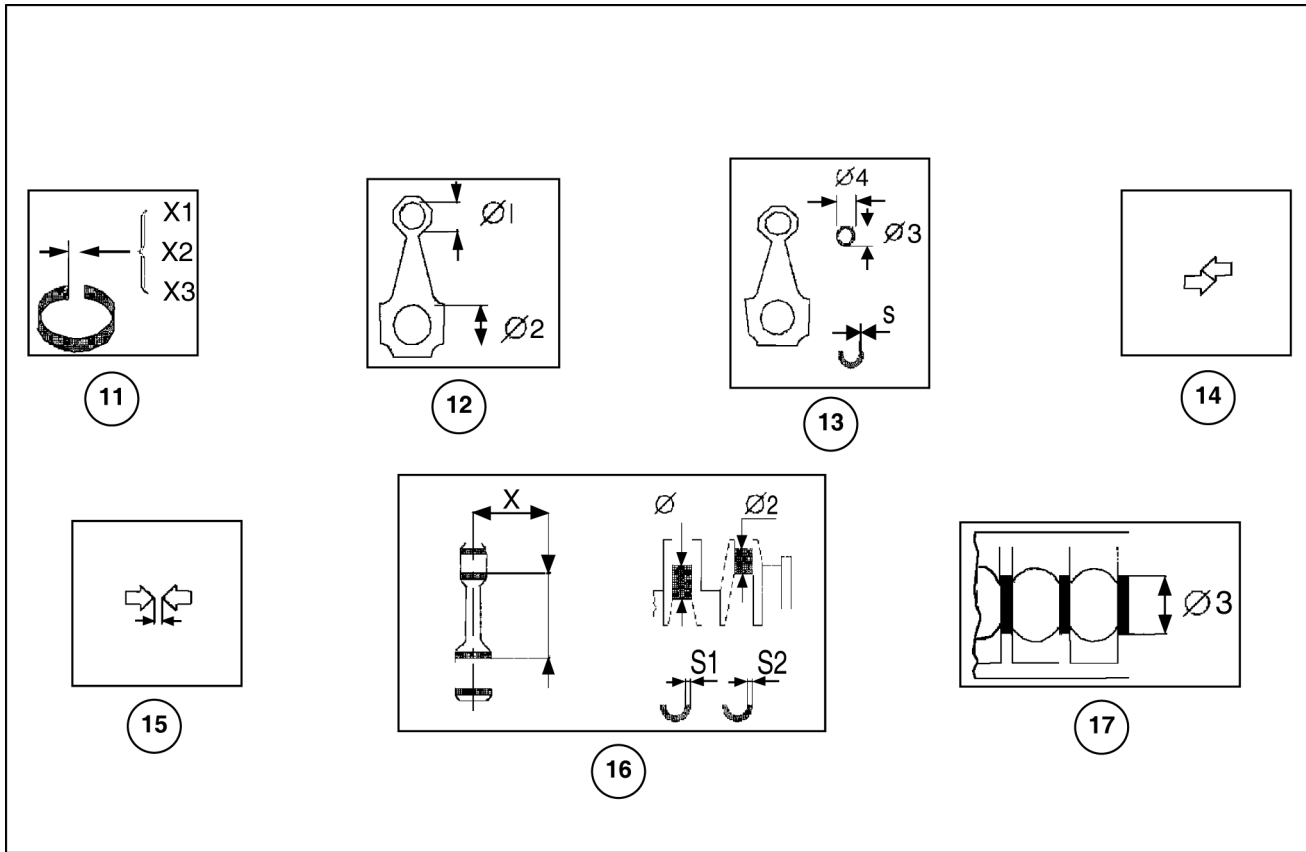

LAIL11CD1685F0A 2

11.	Clearances of the plunger rings in the cylinder liner	$X1 = 0.30 - 0.40 \text{ mm (0.0118 - 0.0157 in)}$
		$X2 = 0.60 - 0.80 \text{ mm (0.0236 - 0.0315 in)}$
		$X3 = 0.30 - 0.55 \text{ mm (0.0118 - 0.0217 in)}$
12.	Seat of the bushing of the small end of the connecting rod	$\text{Ø}1 = 40.987 - 41.553 \text{ mm (1.6137 - 1.6359 in)}$
	Seat of the connecting rod bushing	$\text{Ø}2 = 72.987 - 73.013 \text{ mm (2.8735 - 2.8745 in)}$
13.	Seat of the bushings of the larger end of the connecting rod	Outside $\text{Ø}4 = 41.279 - 41.553 \text{ mm (1.6252 - 1.6359 in)}$
		Inside $\text{Ø}3 = 38.019 - 38.033 \text{ mm (1.4968 - 1.4974 in)}$
14.	Seat of the bushing of the small end of the connecting rod	$0.266 - 0.566 \text{ mm (0.0105 - 0.0223 in)}$
15.	Plunger pin – Bushing	$0.019 - 0.039 \text{ mm (0.0007 - 0.0015 in)}$
16.	Measurement dimension	No information available
	Maximum error in parallelism of the connecting rod axle	No information available
	Bushing trunnions	$\text{Ø}1 = 82.990 - 83.010 \text{ mm (3.2673 - 3.2681 in)}$
	Crankshaft pins	$\text{Ø}2 = 68.987 - 69.013 \text{ mm (2.7160 - 2.7170 in)}$
	Main bushings (supplied as spares)	$S1 = 2.456 - 2.464 \text{ mm (0.0967 - 0.0970 in)}$
	Connecting rod bushings	$S2 = 1.955 - 1.968 \text{ mm (0.0770 - 0.0775 in)}$
17.	Main journals – Trunnions	Numbers 1, 7 $\text{Ø}3 = 87.982 - 88.008 \text{ mm (3.4639 - 3.4649 in)}$
		Numbers 2, 3, 4, 5, 6 $\text{Ø}3 = 87.977 - 88.013 \text{ mm (3.4637 - 3.4651 in)}$

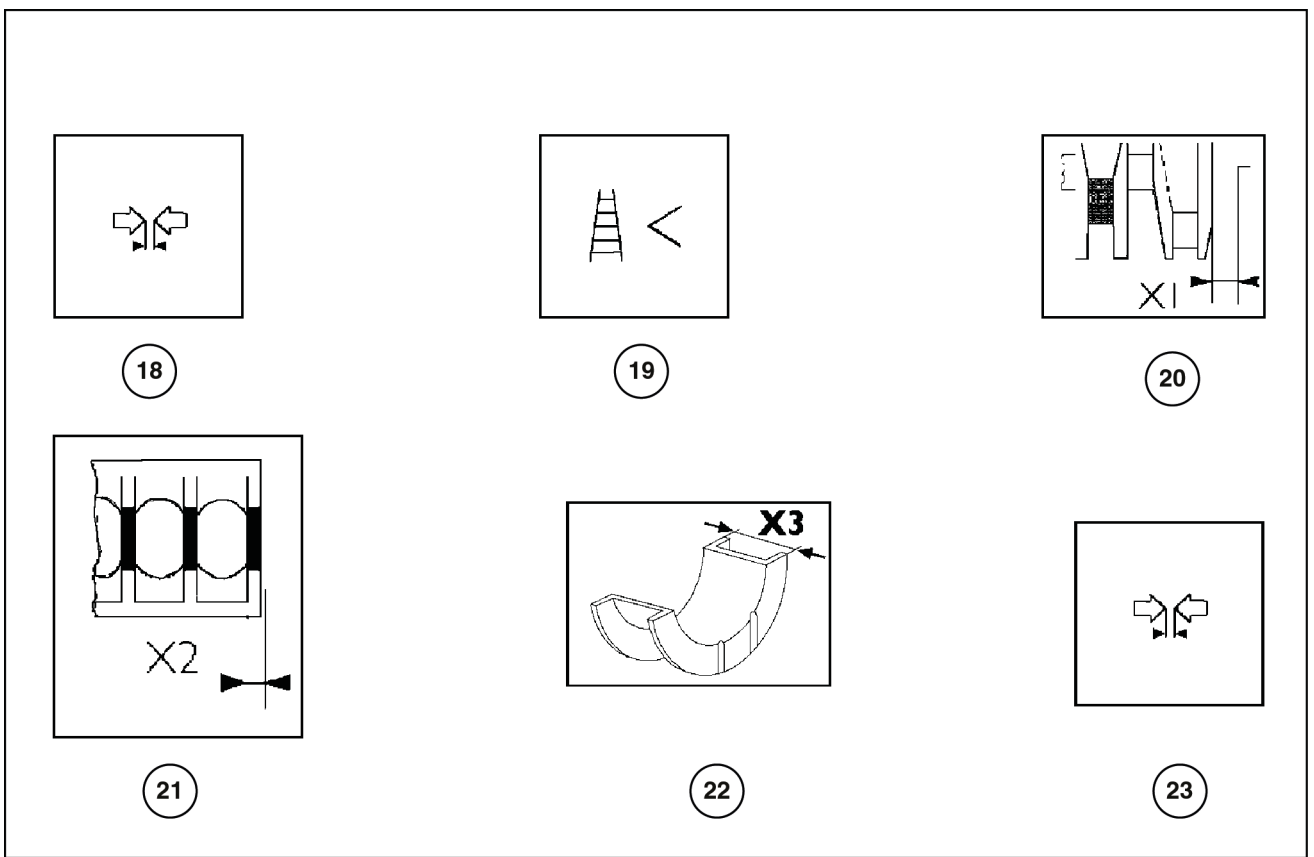

LAIL11CD1589F0A 3

18.	Bushings – Trunnions	Numbers 1, 7 <b>0.044 - 0.106 mm (0.0017 - 0.0042 in)</b>
		Numbers 2, 3, 4, 5, 6 <b>0.041 - 0.103 mm (0.0016 - 0.0041 in)</b>
	Bushings – Crankshaft pins	<b>0.039 - 0.111 mm (0.0015 - 0.0044 in)</b>
19.	Main bushings	<b>+ 0.250 mm (0.0098 in)</b>
	Bushings of the larger end of the connecting rods	<b>+ 0.500 mm (0.0197 in)</b>
20.	Thrust bearing main trunnion	<b>X1 = 37.475 - 37.545 mm (1.4754 - 1.4781 in)</b>
21.	Thrust bearing housing on the main journal	<b>X2 = 25.980 - 26.480 mm (1.0228 - 1.0425 in)</b>
22.	Shoulder bushing	<b>X3 = 37.280 - 37.380 mm (1.4677 - 1.4717 in)</b>
23.	Crankshaft shoulder	<b>0.095 - 0.265 mm (0.0037 - 0.0104 in)</b>



## Engine - Remove

**NOTE:** If the machine is equipped with a brush shield, continue to item 1. Otherwise, go to item 2.

1. Attach appropriate lifting equipment to the brush shield. Remove the two lower bolts and jam nuts. Remove the two upper bolts and washers that secure the upper brush shield. Remove the brush shield.
2. Open the engine side panels. Disconnect the hose from the coolant reservoir. Remove the engine side panels.
3. Make sure that the engine is cold. Slowly remove the radiator cap. Connect a hose to the drain valve. Drain the contents of the radiator into a suitable container.
4. Place a label on the wires. Disconnect the wires from the air filter restriction switch.

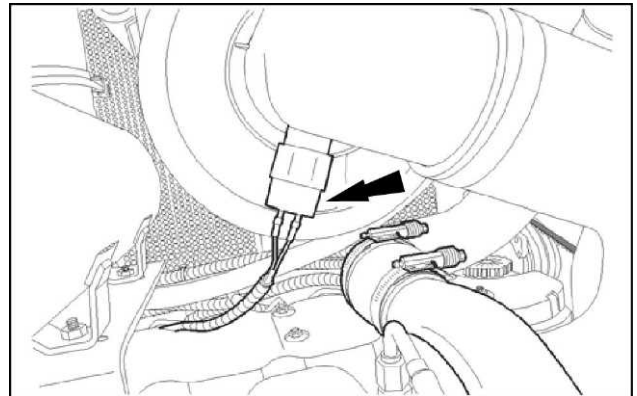

LAIL11CD0252A0A 1

5. Remove the after cooler line.

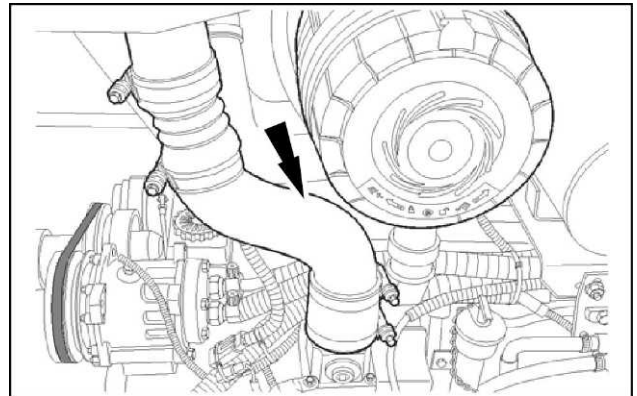

LAIL11CD0253A0A 2

6. Remove the air filter hose. Disconnect the crankcase ventilation hose.

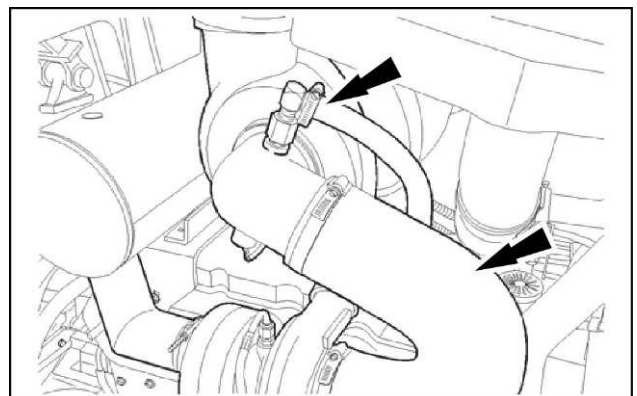

LAIL11CD0254A0A 3

7. Remove the after cooler line.

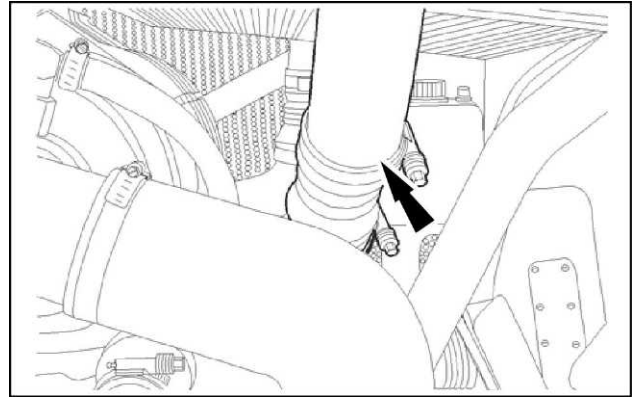

LAIL11CD0255A0A 4

8. Remove the two plugs. Remove the front mounting bolts from the hood.

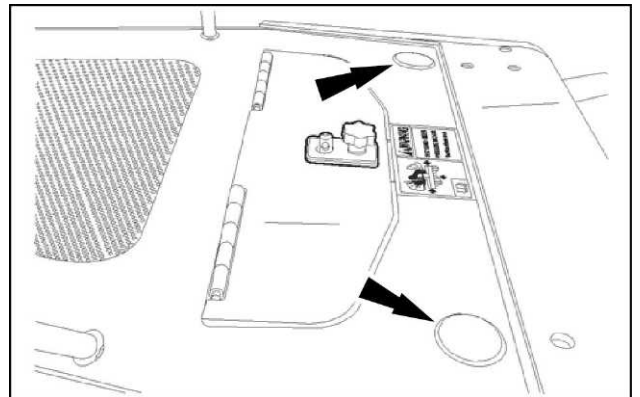

LAIL11CD0256A0A 5

9. Remove the two plugs. Remove the rear mounting bolts from the hood.
10. Connect the lifting equipment to the hood. Remove the hood from the machine.

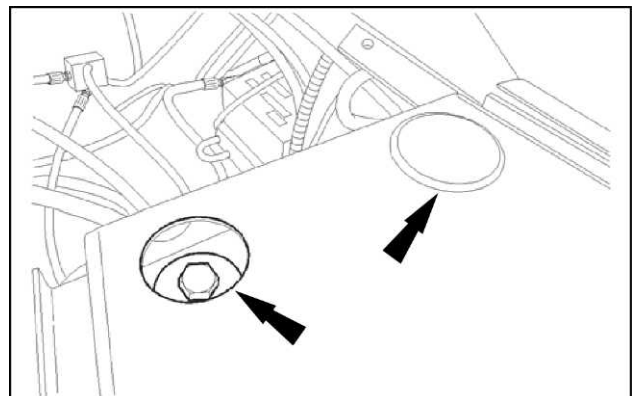

LAIL11CD0257A0A 6

11. Remove the upper radiator hose.

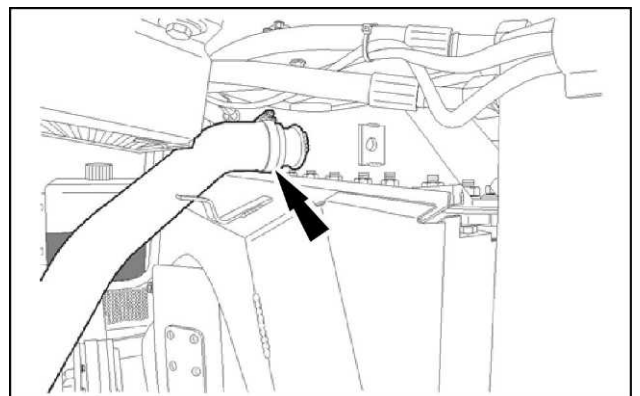

LAIL11CD0258A0A 7

12. Disconnect the lower radiator hose.

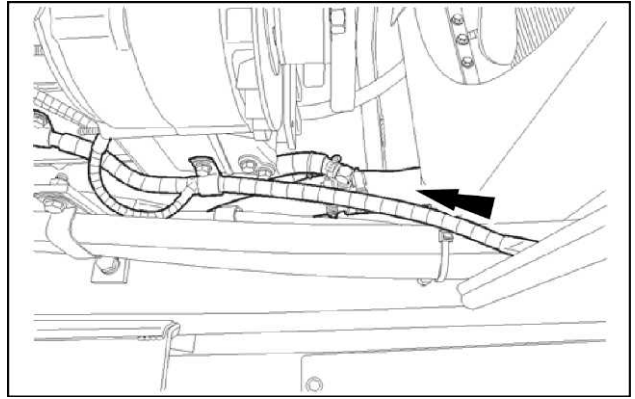

LAIL11CD0259A0A 8

13. Remove the fan and the spacer from the engine.

- (1) Spacer
- (2) Fan mounting bolts (4)

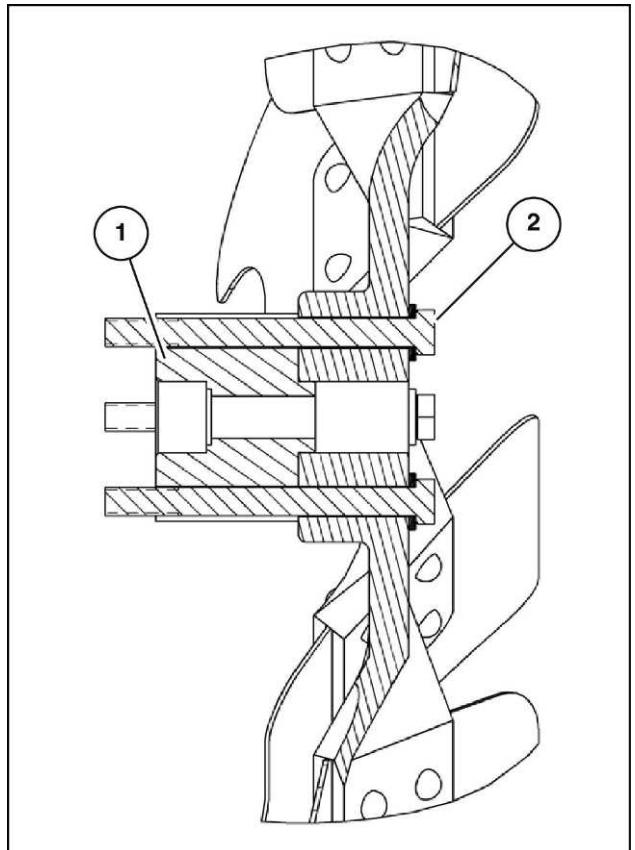

LAIL11CD0369B0A 9

14. Tilt the cab or ROPS canopy. See **Roll Over Protective Structure (ROPS) frame - Tilt (90.114)**.
15. If the machine is equipped with a heater, loosen the fixing clamp. Connect the heater hose.

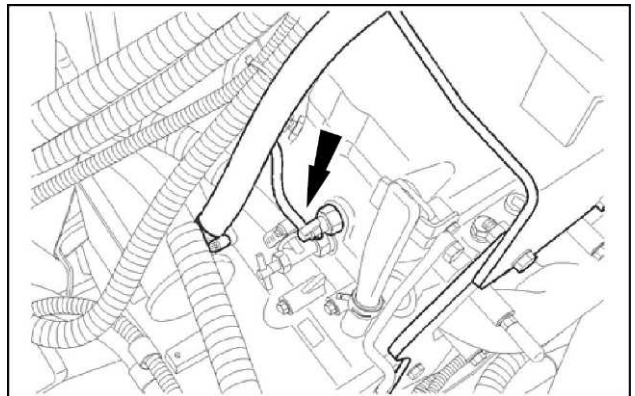

LAIL11CD0260A0A 10

16. Disconnect the alternator wires.

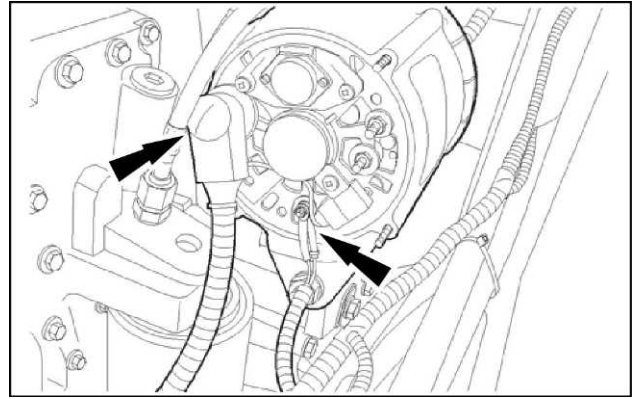

LAIL11CD0261A0A 11

17. Disconnect the battery cable and the electrical harness wires from the starter motor.

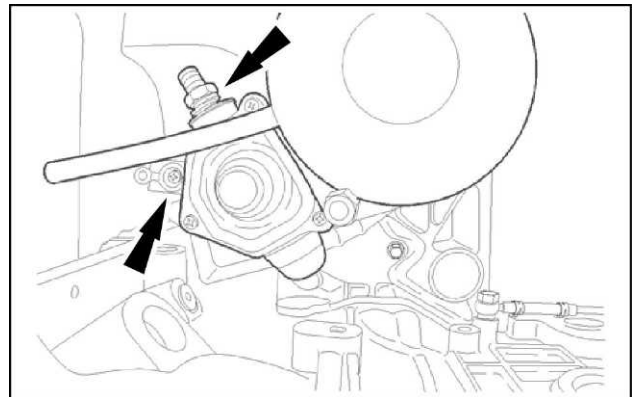

LAIL11CD0262A0A 12

18. Discharge the air-conditioning system, if the machine has one. See **Air conditioning - Charging (50.200)**. Disconnect the clutch electrical connector and the compressor hoses. Plug the hoses and cap the fittings.

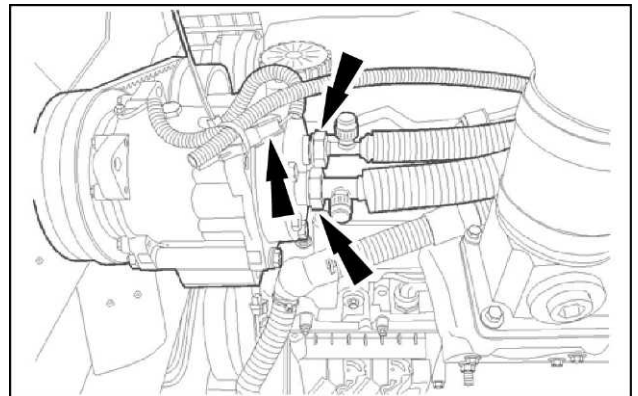

LAIL11CD0263A0A 13

19. Disconnect the electrical connector from the engine controller.

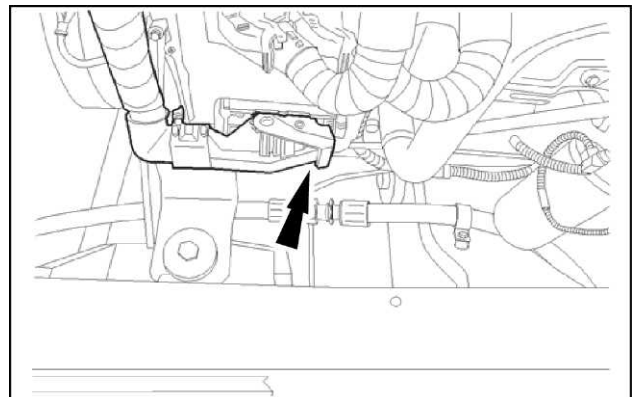

LAIL11CD0264A0A 14

20. Connect a vacuum pump to the fuel tank. Turn on the pump. Disconnect the fuel lines. Cap the lines and fittings. Shut down the vacuum pump.

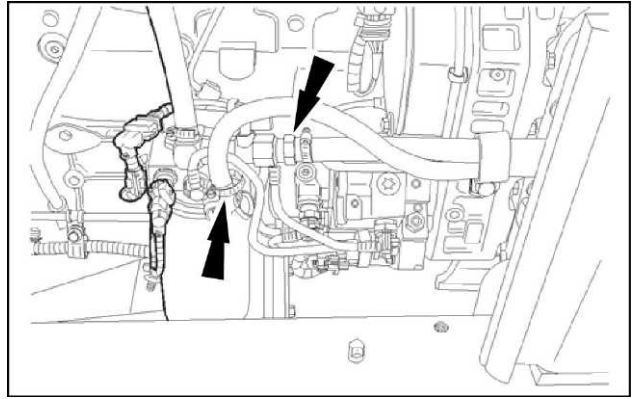

LAIL11CD0265A0A 15

21. Disconnect the ground cable from the drum.
22. Connect lifting equipment to the engine.
23. Remove the engine mounting bolts.
24. List the engine slightly. Move the engine forward. Slide the drive shaft out of the hydro pumps.
25. Remove the engine from the machine.

## Engine - Disassemble

1650L

LA

### Reconditioning the engine on the workbench

1. Remove the drain plug from the crankcase to drain the engine oil.
2. Use the supports to secure the engine to the trestle as follows (work from the left-hand side of the engine).
  - Use a suitable tool to remove the fuel filter (5) from its bracket (1).
  - Disconnect the low pressure lines (2), (3), and (4) from the fuel filter bracket (1).
  - Remove the fuel filter bracket (1) from the engine block.

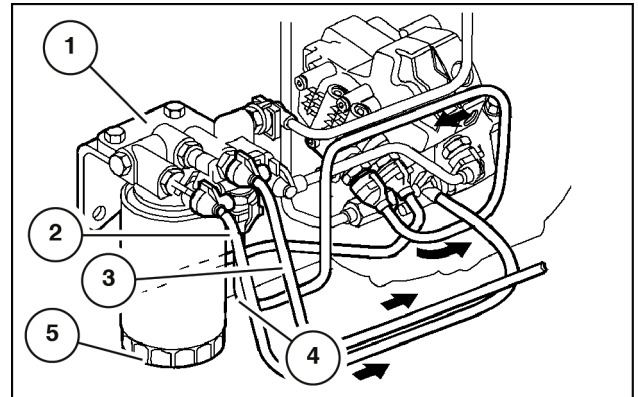

LAIL11CD1407A0A 1

3.

**NOTICE:** Push the clamp (1), as shown in Fig. 2, to disconnect the low pressure fuel lines (2), (3), and (4) from the corresponding fittings. After you disconnect the lines, put the clamp (1) back in the position shown in Fig. 2 to prevent the deformation of the clamp.

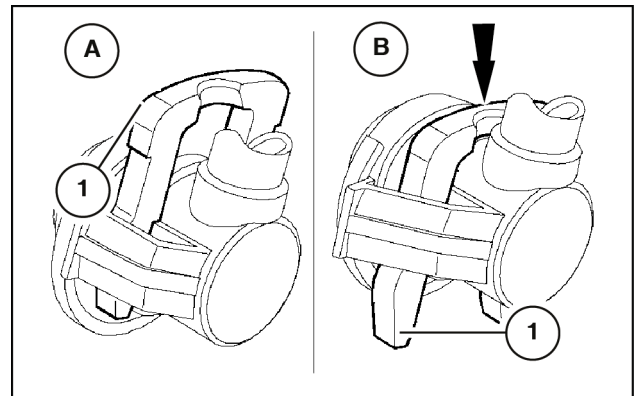

LAIL11CD1408A0A 2

4. Disconnect the fuel line (1) from the "common rail" and from the high pressure pump (5). Remove the mounting bolts (2) to remove the fuel line.

**NOTICE:** When you loosen the fitting (3) of the fuel line (1), use an appropriate wrench so that the fitting (4) of the high pressure pump (5) does not turn.

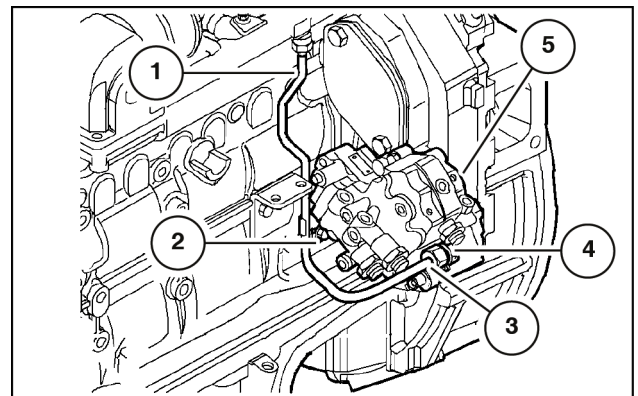

LAIL11CD1409A0A 3

5. From the Right-hand Side:  
 Remove the mounting bolts (2) and the oil lines (3) from the Turbocharger (1) of the engine block.  
 Remove the starter (5) from the engine flywheel housing (4).  
 Secure the engine to an engine support.

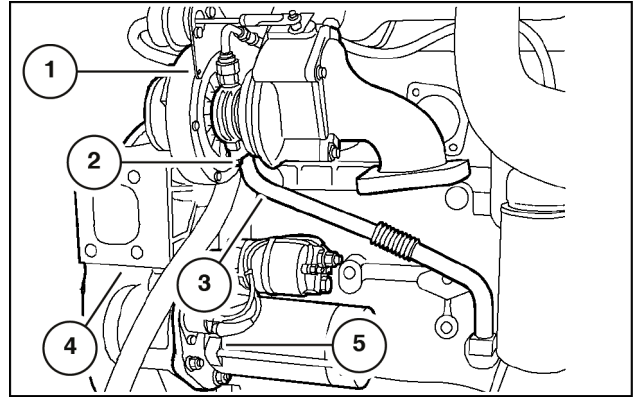

LAIL11CD1410A0A 4

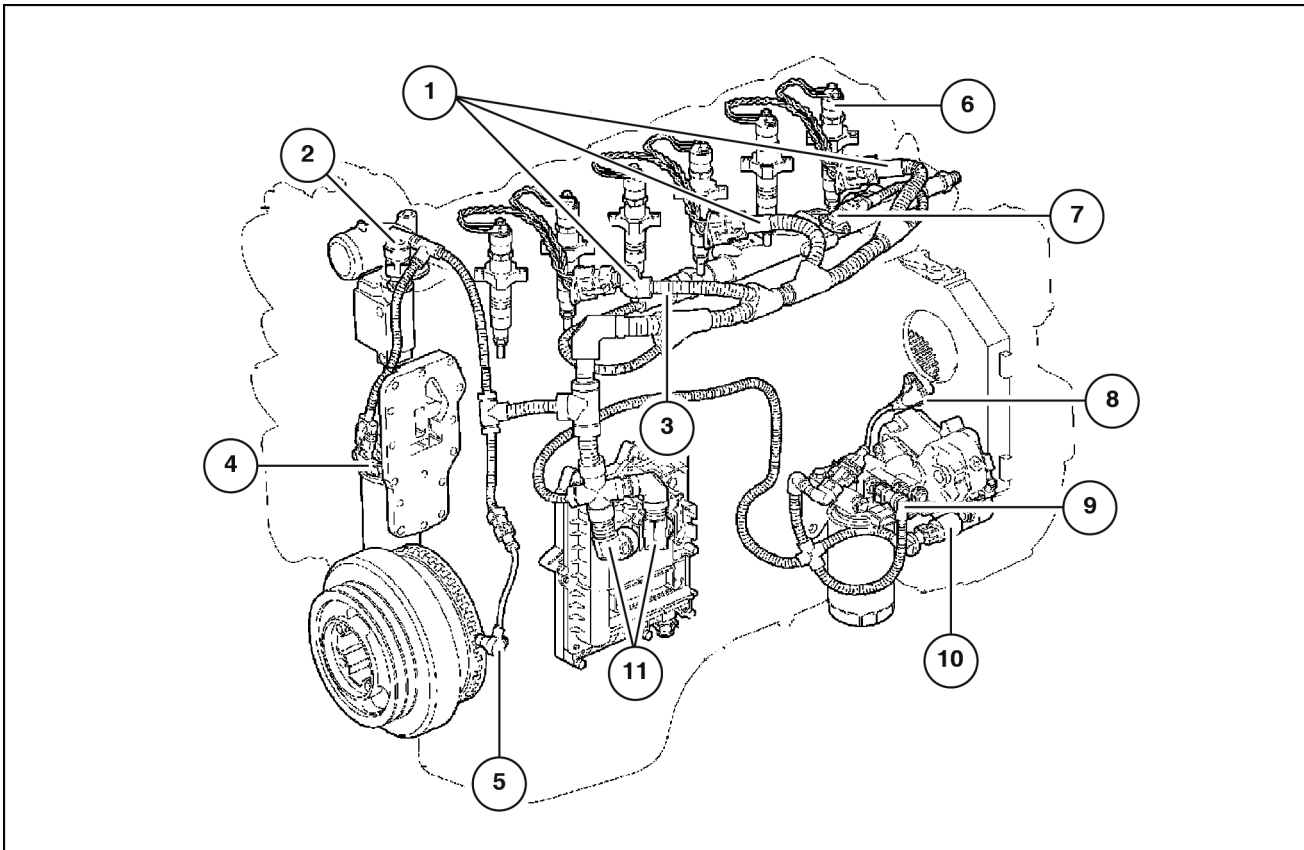

LAIL11CD1463F0A 5

- |                                       |                                   |
|---------------------------------------|-----------------------------------|
| 1. Injector fittings                  | 7. Pressure/temperature sensor    |
| 2. Engine coolant temp sensor         | 8. Camshaft sensor                |
| 3. "Common rail" fuel pressure sensor | 9. Fuel heater temperature sensor |
| 4. Oil pressure-temperature sensor    | 10. High pressure regulator       |
| 5. Crankshaft rotation sensor         | 11. Control unit EDC7UC31         |
| 6. Injector                           |                                   |

6. Disconnect the battery cable. Disconnect the following connectors:

- Connectors (1) of the injector wiring (6).
- Engine coolant temperature sensor on the thermostat (2).
- "Common rail" fuel pressure sensor (3).
- Crankshaft rotation sensor (5).
- Temperature/pressure sensor (7).
- Camshaft sensor (8).
- High pressure regulator (10).
- Control unit EDC7UC31 (11).

7. Disconnect the "common rail" (2):

- Fuel line (4) according to the procedure in Step 3.
- Fuel lines (5).
- Injector manifolds (3).
- Remove the bolts (1). Disconnect the "common rail" (2).

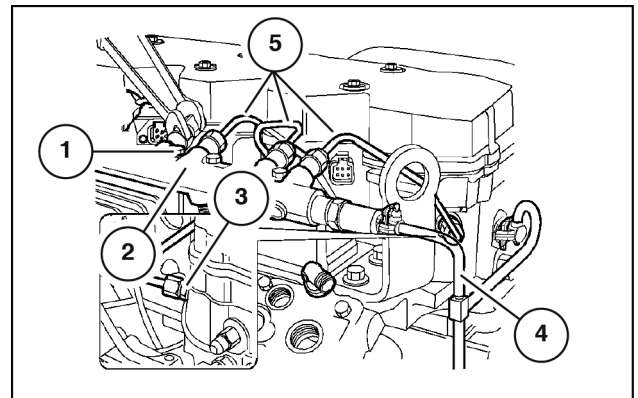

LAIL11CD1411A0A 6

8. Disconnect the line (2) from the fuel return pressure limiter (1), as shown in Step 3. Remove the nut. Loosen the retaining collar. Disconnect the oil steam line (5). Remove the bolts (3). Remove the "blow-by" filter (4).

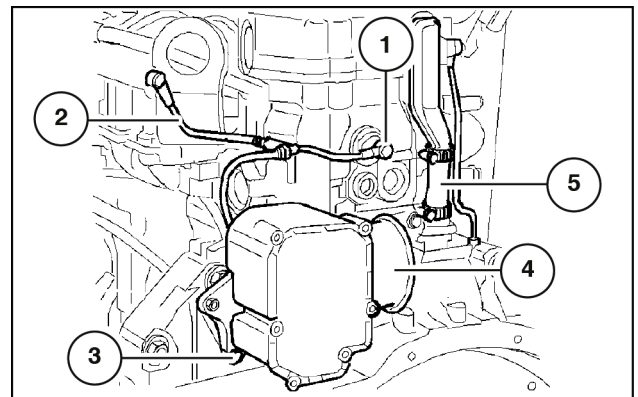

LAIL11CD1412A0A 7

9. Remove the nuts and the cover of the valve tappets, including the gasket. Remove the bolts (1). Disconnect the wiring housing of the injectors (2), along with the gasket. Remove the bolts (5). Shut down the pressure/temperature sensor (6). Remove the nuts (3). Remove the fuel inlet connectors (4).

**NOTICE:** The fuel inlet connectors (4) should not be re-used. The fuel inlet connectors should be replaced with new fuel inlet connectors.

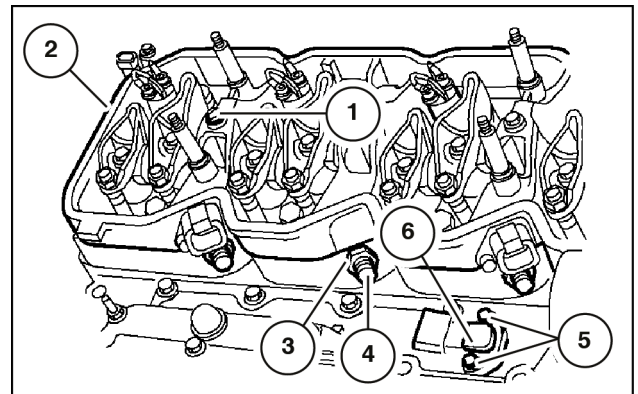

LAIL11CD1413A0A 8



10. Loosen the adjustment nuts of the valve tappets **(1)**. Unscrew the adjusters. Remove the bolts **(2)**. Remove the rocker arm assembly **(3)**, which consists of the support **(6)**, the rocker arms **(4)**, and the shafts **(5)**. Remove the valve bridges **(7)**. Remove the rods **(8)**.

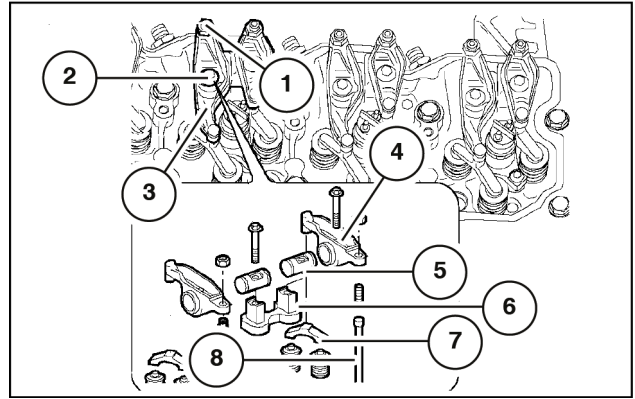

LAIL11CD1414A0A 9

11. Remove the injector mounting bolts. Use the Special Tool **380001099 (1)** to remove the injectors **(2)** from the poppet.

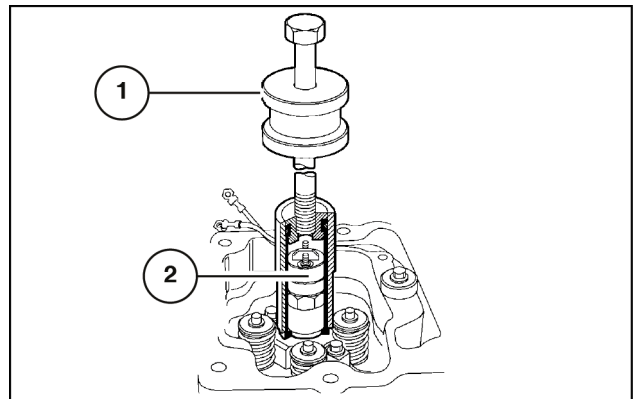

LAIL11CD1415A0A 10

12. If equipped, remove the deflector **(5)** from the turbocharger **(1)**. Disconnect the oil line **(3)** from the oil filter support of the heat exchanger. Remove the nuts **(2)**. Separate the turbocharger **(1)** from the exhaust manifold **(4)**.

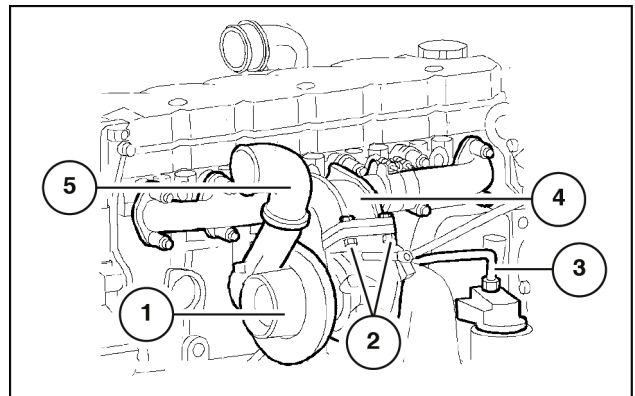

LAIL11CD1416A0A 11

13. Remove the mounting bolts **(1)**. Remove the exhaust manifold in two sections **(2)** and **(3)** with the respective seals.

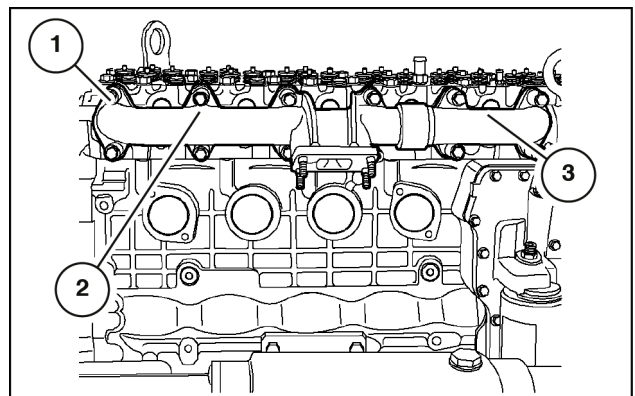

LAIL11CD1417A0A 12

14. Remove the bolts (1). Disconnect the intake manifold and the air deflector from the heater (2). Remove the bolts (4). Remove the thermostat housing (3). Remove the thermostat under the housing. Remove the mounting bolts (5) from the poppet (6).

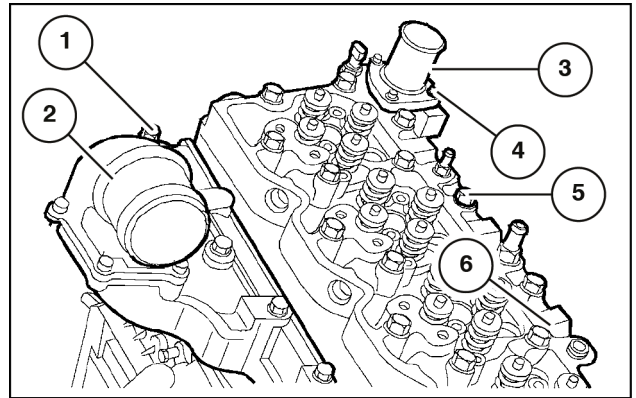

LAIL11CD1418A0A 13

15. Install supports (1) on the poppet. Use a hoist to remove the poppet from the cylinder block.

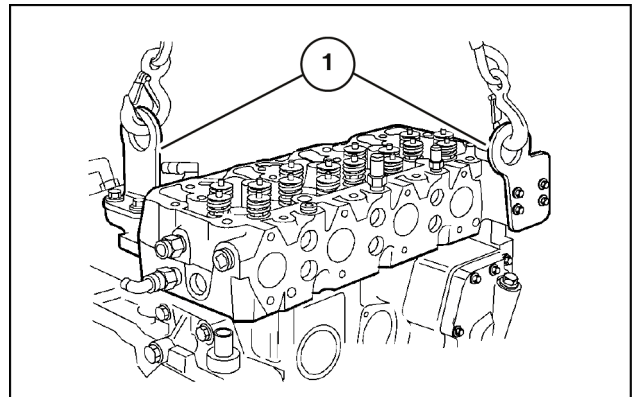

LAIL11CD1419A0A 14

16. Remove the head gasket (1).

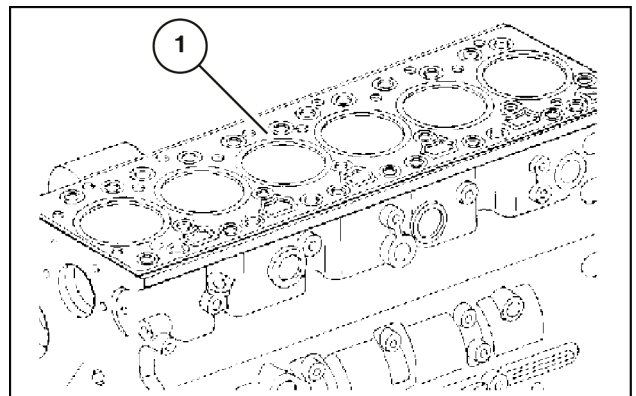

LAIL11CD1420A0A 15

17. Loosen the drive belt tensioner (2). Remove the drive belt (3) from the pulleys. Then remove the belt tensioner (2). Remove the bolts that secure the alternator to the bracket. Remove the alternator (1).

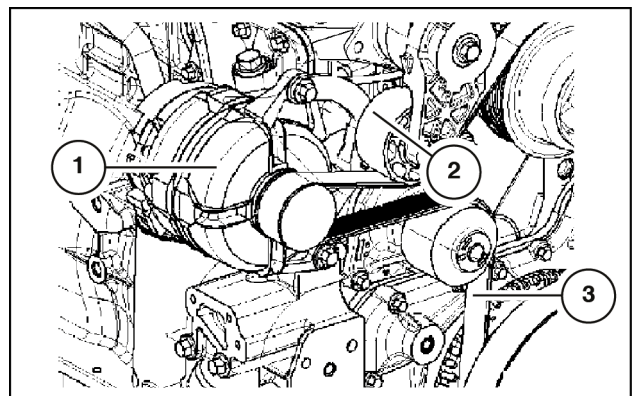

LAIL11CD1421A0A 16

This as a preview PDF file from [best-manuals.com](http://best-manuals.com)



Download full PDF manual at [best-manuals.com](http://best-manuals.com)