

CX160 Crawler Excavators

Table of Contents

DIVISION/SECTION	SECTION N°	REFERENCE N°
1 GENERAL INFORMATION		
Safety, general information and standard torque data	1001	7-27690GB
General specifications and special torque setting.....	1002	7-27712GB
2 ENGINE		
Removal and installation of the engine	2000	7-28220GB
Radiator and oil-cooler	2001	7-28040GB
Engine specifications	*	
Disassembly and assembly of the engine.....	*	
3 FUEL SYSTEM		
Fuel tank	3001	7-27970GB
Fuel engine system.....	*	
4 ELECTRICAL SYSTEM		
Electrical system, electrical and electronic troubleshooting	4001	7-27721GB
Inspection and maintenance of batteries and connecting a booster battery	4002	7-27921GB
Main and engine electronic control boxes.....	4003	7-27931GB
5 UNDERCARRIAGE		
Removal and installation of tracks	5001	7-27750GB
Rollers.....	5003	7-27770GB
Sprocket.....	5004	7-27781GB
Idler wheel and tension shock absorber	5005	7-27801GB
6 DRIVE TRAIN		
Drive motor and final drive transmission removal and installation	6001	7-27841GB
Drive motor and final drive transmission disassembly and assembly	6002	7-29860GB
Swing reduction gear, removal and installation.....	6003	7-29900GB
Swing reduction gear, disassembly and assembly	6004	7-28370GB
7 UNDERCARRIAGE HYDRAULICS		
8 UPPERSTRUCTURE HYDRAULICS		
Depressurising and decontaminating the hydraulic system, use of the vacuum pump and bleeding the components	8000	7-27951GB
Specifications, troubleshooting, checks and hydraulic pressure settings	8001	7-27701GB
Hydraulic reservoir removal and installation	8002	7-27990GB
Main and pilot pumps, removal and installation	8003	7-27870GB
Main hydraulic control valve, removal and installation	8004	7-27880GB
Attachment cylinders, removal and installation	8005	7-27791GB
Hydraulic swivel, removal and installation	8006	7-27811GB
Pilot blocs, removal and installation.....	8007	7-28100GB
Swing motor, removal and installation	8008	7-29890GB
Main hydraulic pump, disassembly and assembly.....	8010	7-29770FR
Main hydraulic control valve, disassembly and assembly.....	8011	7-28200FR
Attachment cylinders, disassembly and assembly.....	8012	7-27900GB
Hand control levers, disassembly and assembly	8013	7-28110GB
Foot control levers, disassembly and assembly	8014	7-28300FR
Six-solenoid valves, disassembly and assembly	8015	7-27910GB
Caution valve, disassembly and assembly	8016	7-27940GB
Safety vave	8017	7-29630GB
Hydraulic swivel, disassembly and assembly	8018	7-28080GB
Swing motor, disassembly and assembly	8019	7-28010GB
Hydraulic functions.....	8020	7-28480GB

DIVISION/SECTION	SECTION N°	REFERENCE N°
9 UPPERSTRUCTURE		
Upperstructure, turntable and counterweight.....	9002	7-27981GB
Boom, dipper and bucket.....	9003	7-27961GB
Seat and seat belt.....	9004	7-28120GB
Cab and cab equipment.....	9005	7-28021GB
Air conditioning troubleshooting.....	9006	██████████
Air conditioning unit disassembly and assembly.....	9007	██████████
Air conditioning servicing.....	9008	██████████
Air conditioning components.....	9009	██████████
Large format hydraulic and electrical schematics.....	Pocket	7-27612

* Consult the Engine Service Manual

██████████ Sections to be distributed at a later date

NOTE: CASE Company reserves the right to make changes in the specification and design of the machine without prior notice and without incurring any obligation to modify units previously sold.

The description of the models shown in this manual has been made in accordance with the technical specifications known as of the date of design of this document.

Section

1001

SAFETY, GENERAL INFORMATION AND TORQUE SPECIFICATIONS

TABLE OF CONTENTS

GENERAL INFORMATION	3
SAFETY	4
STANDARD TORQUE DATA FOR CAP SCREWS AND NUTS.....	6



WARNING : *This symbol is used in this manual to indicate important safety messages. Whenever you see this symbol, carefully read the message that follows, as there is a risk of serious injury.*

GENERAL INFORMATION

Cleanning

Clean all metal parts except bearings, in a suitable cleaning solvent or by steam cleaning. Do not use caustic soda for steam cleaning. After cleaning, dry and put oil on all parts. Clean oil passages with compressed air. Clean bearings in a suitable cleaning solvent, dry the bearings completely and put oil on the bearings.

Inspection

Check all parts when the parts are disassembled. Replace all parts that have wear or damage. Small scoring or grooves can be removed with a hone or crocus cloth. Complete a visual inspection for indications of wear, pitting and the replacement of parts necessary to prevent early failures.

Bearings

Check bearings for easy action. If bearings have a loose fit or rough action replace the bearing. Wash bearings with a suitable cleaning solvent and permit to air dry. DO NOT DRY BEARINGS WITH COMPRESSED AIR.

Needle bearings

Before you press needle bearings in a bore always remove any metal protrusions in the bore or edge of the bore. Before you press bearings into position put petroleum jelly on the inside and outside diameter of the bearings.

Gears

Check all gears for wear and damage. Replace gears that have wear or damage.

Oil seals, O-rings and gaskets

Always install new oil seals, O-rings and gaskets. Put petroleum jelly on seals and O-rings.

Shafts

Check all shafts that have wear or damage. Check the bearing and oil seal surfaces of the shafts for damage.

Service parts

Always install genuine Case service parts. When ordering refer to the Parts Catalog for the correct part number of the genuine Case replacement items. Failures due to the use of other than genuine Case replacement parts are not covered by warranty.

Lubrication

Only use the oils and lubricants specified in the Operator's or Service Manuals. Failures due to the use of non-specified oils and lubricants are not covered by warranty.

SAFETY



This symbol means ATTENTION! BECOME ALERT! YOUR SAFETY IS INVOLVED. The message that follows the symbol contains important information about safety. Carefully read the message. Make sure you fully understand the causes of possible injury or death.

To prevent injury always follow the Warning, Caution and Danger notes in this section and throughout the manual.

Put the warning tag shown below on the key for the keyswitch when servicing or repairing the machine. One warning tag is supplied with each machine. Additional tags Part Number 331-4614 are available from your service parts supplier



WARNING: *Read the operator's manual to familiarize yourself with the correct control functions.*



WARNING: *Operate the machine and equipment controls from the seat position only. Any other method could result in serious injury.*



WARNING: *This is a one man machine, no riders allowed.*



WARNING: *Before starting engine, study Operator's Manual safety messages. Read all safety signs on machine. Clear the area of other persons. Learn and practice safe use of controls before operating.*

It is your responsibility to understand and follow manufacturers instructions on machine operation, service and to observe pertinent laws and regulations. Operator's and Service Manuals may be obtained from your Case dealer.



WARNING: *If you wear clothing that is too loose or do not use the correct safety equipment for your job, you can be injured. Always wear clothing that will not catch on objects. Extra safety equipment that can be required includes hard hat, safety shoes, ear protection, eye or face protection, heavy gloves and reflector clothing.*



WARNING: *When working in the area of the fan belt with the engine running, avoid loose clothing if possible, and use extreme caution.*



WARNING: *When doing checks and tests on the equipment hydraulics, follow the procedures as they are written. DO NOT change the procedure.*



WARNING: *When putting the hydraulic cylinders on this machine through the necessary cycles to check operation or to remove air from a circuit, make sure all people are out of the way.*



WARNING: Use insulated gloves or mittens when working with hot parts.



WARNING: Lower all attachments to the ground or use stands to safely support the attachments before you do any maintenance or service.



WARNING: Pin sized and smaller streams of hydraulic oil under pressure can penetrate the skin and result in serious infection. If hydraulic oil under pressure does penetrate the skin, seek medical treatment immediately. Maintain all hoses and tubes in good condition. Make sure all connections are tight. Make a replacement of any tube or hose that is damaged or thought to be damaged. DO NOT use your hand to check for leaks, use a piece of cardboard or wood.



WARNING: When removing hardened pins such as a pivot pin, or a hardened shaft, use a soft head (brass or bronze) hammer or use a driver made from brass or bronze and a steel head hammer.



WARNING: When using a hammer to remove and install pivot pins or separate parts using compressed air or using a grinder, wear eye protection that completely encloses the eyes (approved goggles or other approved eye protectors).



WARNING: Use suitable floor (service) jacks or chain hoist to raise wheels or tracks off the floor. Always block machine in place with suitable safety stands.



WARNING: When servicing or repairing the machine, keep the shop floor and operator's compartment and steps free of oil, water, grease, tools, etc. Use an oil absorbing material and/or shop cloths as required. Use safe practices at all times.



WARNING: Some components of this machine are very heavy. Use suitable lifting equipment or additional help as instructed in this Service Manual.



WARNING: Engine exhaust fumes can cause death. If it is necessary to start the engine in a closed place, remove the exhaust fumes from the area with an exhaust pipe extension. Open the doors and get outside air into the area.



WARNING: When the battery electrolyte is frozen, the battery can explode if (1), you try to charge the battery, or (2), you try to jump start and run the engine. To prevent the battery electrolyte from freezing, try to keep the battery at full charge. If you do not follow these instructions, you or others in the area can be injured.

STANDARD TORQUE DATA FOR CAP SCREWS AND NUTS

Tightening of cap screws, nuts

Tighten alternately so that tightening torque can be applied evenly. The numbers in the figure below indicate the order of tightening.

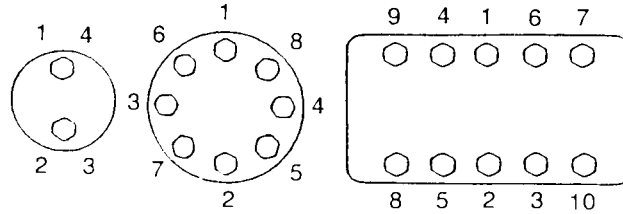

JS00481A

Cap screws which have had Loctite used (white residue remains after removal) should be cleaned with light oil or suitable cleaning solvent and dried. Apply 2-3 drops of Loctite to the thread portion of the cap screw and then tighten.

Torque table

Tighten cap screws and nuts according to the table below if there are no other special instructions.

Cap Screw Name Size (Size)			M6	M8	M10	M12	M14	M16	M18	M20
Cap Screw	Spanner	[mm]	10	13	17	19	22	24	27	30
		[in.]	0.39	0.51	0.67	0.75	0.87	0.95	1.06	1.18
	Tightening torque	[Nm]	6.9	15.7	32.3	58.8	98.0	137.2	196.0	274.0
		[lb-ft]	5.1	11.6	23.9	43.4	72.3	101.2	144.6	202.4
Socket Head Cap Screw	Spanner	[mm]	5	6	8	10	12	14	14	17
		[in.]	0.20	0.24	0.32	0.39	0.47	0.55	0.55	0.67
	Tightening torque	[Nm]	8.8	21.6	42.1	78.4	117.6	176.4	245.0	343.0
		[lb-ft]	6.5	15.9	31.1	57.8	86.8	130.1	180.8	253.1

Section 1002

1002

GENERAL SPECIFICATIONS AND SPECIAL TORQUE SETTINGS

TABLE OF CONTENTS

TYPE, SERIAL NUMBER AND YEAR OF MANUFACTURE OF THE MACHINE	3
Machine.....	3
Engine	3
Component serial numbers	3
FLUIDS AND LUBRICANTS	4
Hydraulic fluid.....	4
Transmission component oil	4
Grease	4
Engine oil	5
Oil viscosity/Oil range.....	5
Fuel	6
Anti-freeze/Anti-corrosion.....	6
Environment	6
Components made from plastic or resin	6
SPECIFICATIONS.....	7
Engine	7
Capacities	7
Electrical system	7
Hydraulic system.....	8
Cylinder	8
Control valve	9
Swing	9
Travel	9
Undercarriage	9
Attachment.....	10
Weight of components	10
DIMENSIONS AND LIMIT OF WEAR AND TEAR OF THE TRACKS SET	11
Toothed wheel.....	11
Idler wheel.....	12
Upper roller	13
Lower roller	14
Track	15
DIMENSIONS AND LIMIT OF WEAR AND TEAR OF THE MOBILE JOINTS OF THE ATTACHMENT.....	16
1. Boom foot/Undercarriage	16
2. Boom cylinder foot/Undercarriage.....	17
3. Boom cylinder head/Boom	17
4. Dipper cylinder foot/Boom	18
5. Boom/Dipper	18
6. Dipper cylinder head/Dipper.....	18
7. Bucket cylinder foot/Dipper	19
8. Connecting rod/Dipper	19
9. Compensator/Bucket.....	19
10. Connecting rod/Compensator/Bucket cylinder head.....	20
11. Dipper/Bucket.....	20
SPECIAL TORQUE SETTINGS	21
MACHINE OVERALL DIMENSIONS CX130 CX160.....	24
MACHINE OVERALL DIMENSIONS CX180.....	25



WARNING: *This symbol is used in this manual to indicate important safety messages. Whenever you see this symbol, carefully read the message that follows, as there is a risk of serious injury.*

TYPE, SERIAL NUMBER AND YEAR OF MANUFACTURE OF THE MACHINE

When placing a parts order or making a request for information or assistance, always give you CASE Dealer the type and serial number of the machine concerned.

Enter the required information on the lines below: Type, serial number, year of manufacture of the machine and the serial numbers of hydraulic and mechanical components.

Machine

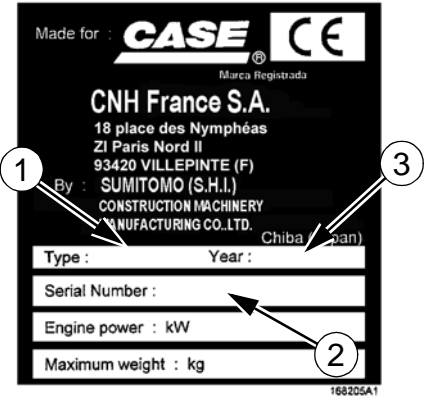
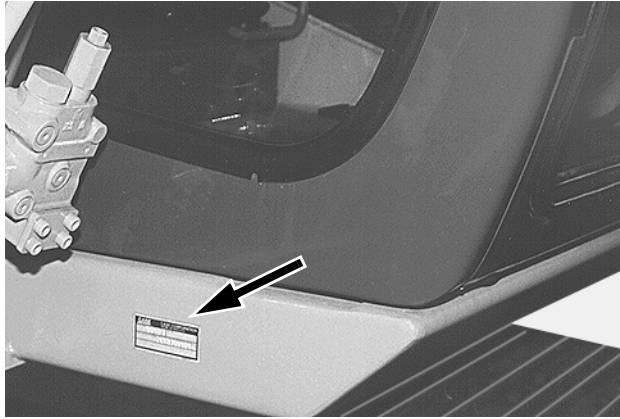

CS01J532

- (1) Type.....
- (2) Serial number.....
- (3) Year of manufacture.....

Engine

Make and type.....

Serial number

Component serial numbers

Hydraulic pump.....

Swing reduction gear.....

Travel reduction gears.....

Travel control valve.....

Attachment control valve

Swing control valve.....

FLUIDS AND LUBRICANTS

Lubricants must have the correct properties for each application.



WARNING: *The conditions of use for individual fluids and lubricants must be respected.*

Hydraulic fluid

CASE hydraulic fluid is specially designed for high pressure applications and for the CASE hydraulic system. The type of fluid to be used depends on the ambient temperature.

Temperate climates

-20°C to +40°C
Fluid type ISO VG 46
CASE reference: POHYDR

Hot climates

0°C to +60°C
Fluid type ISO VG 100
CASE reference: POHYPC

Cold climates

-40°C to +20°C
Fluid type ISO VG 22
CASE reference: POHYPF

These various grades of fluid must be in conformity with the CASE specification.

Transmission component oil

Extreme pressure oil used for transmission components inside sealed housings.

Extreme pressure oil TYPE API GL5 GRADE 80W90 or ISO VG 150.

Grease

The type of grease to use depends on ambient temperature.

Temperate and hot climates

-20°C to +60°C
Extreme pressure grease EP NLGI grade 2 with molybdenum disulphide.

Cold climates

-40°C to +20°C
Extreme pressure grease EP NLGI grade 0.

Engine oil

CASE engine oil No. 1 is recommended for your engine. This oil ensures correct lubrication of your engine in all working conditions.

If CASE No. 1 Multiperformance or Performance engine oil is not available, use oil corresponding to category API/CG/CF.

NOTE: Do not put any Performance Additive or other additive in the sump. Oil change intervals shown in this manual are based on tests carried out on CASE lubricants.



RD97F136



RD97F100

Oil viscosity/Oil range

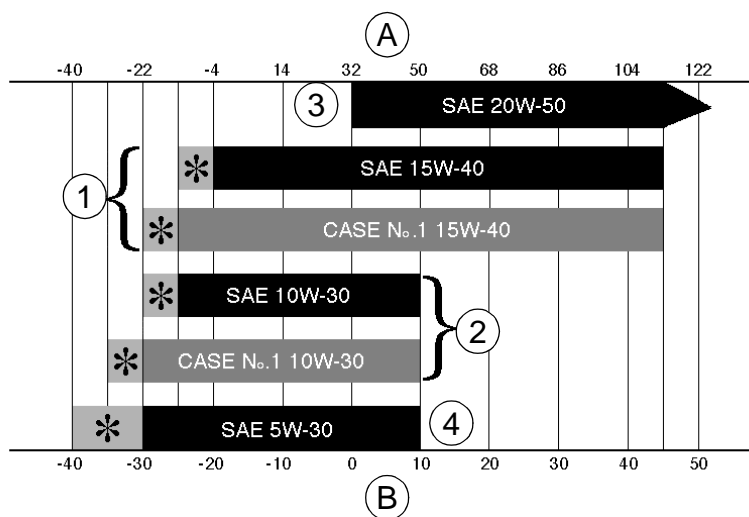

(A) FAHRENHEIT TEMPERATURE

(B) CELSIUS TEMPERATURE

(1) ALL SEASONS

(2) WINTER

(3) TROPICAL

(4) ARCTIC

(*) SHOWS THAT AN ENGINE OIL HEATER OR ENGINE COOLANT SOLUTION HEATER MUST BE USED

CS98M561

Fuel

Use fuel that is to ASTM (American Society for Testing and Materials) D975 standard.

Use Grade No. 2 fuel. The use of other types of fuel can result in a loss of power and may cause high fuel consumption.

In cold weather, the use of a mixture of fuels No. 1 and No. 2 is temporarily permitted. Consult your fuel supplier.

If the temperature falls below the fuel cloud point (point at which wax begins to form) the wax crystals will cause power loss or will prevent the engine from starting.

IMPORTANT: *In cold weather, fill the fuel tank at the end of the day's work, in order to prevent the formation of condensation.*

Fuel storage

Long storage can lead to the accumulation of impurities and condensation in the fuel. Engine trouble can often be traced to the presence of water in the fuel.

The storage tank must be placed outside and the temperature of the fuel should be kept as low as possible. Drain off water and impurities regularly.

Anti-freeze/Anti-corrosion

Use anti-freeze in all seasons to protect the cooling system from corrosion and all risk of freezing.

In environments with a temperature higher than -36°C, use a mixture of 50% ethylene-glycol based anti-freeze.

For areas where the temperature is below -36°C, it is advisable to use a blend of 40% water and 60% anti-freeze.

Environment

Before carrying out any servicing operation on this machine and before disposing of used fluids or lubricants, always think of the environment. Never throw fluid or oil on the ground and never keep them in leaking receptacles.

Consult your local ecological recycling centre to obtain information on the appropriate means of disposing of these substances.

Components made from plastic or resin

When cleaning plastic parts, the console, the instrument panel, the gauges, etc., do not use petrol (gasoline), paraffin (kerosene), paint solvents, etc. Use only water, soap and a soft cloth.

The use of petrol (gasoline), paraffin (kerosene), paint solvents, etc, will cause discoloration, cracking or deformation of these components.

SPECIFICATIONS

CX130

CX160

CX180

Engine

Make..... Isuzu..... ←

Model..... BB-4BG1TRA-01DD-4BG1TRA-02←

Type: Four stroke, water-cooled, overhead valve, direct injection (electronically controlled), in-line engine with turbo-charger.

Number of cylinders..... 4..... ←

Bore and stroke..... 105x125mm..... ←

Displacement..... 4329cm³..... ←

Operating conditions

Idling..... 1000 tr/mn..... ←

Max speed..... 2100 tr/mn..... 2200 tr/mn..... ←

ECC 1289 power rating..... 66,2 KW (89cv)..... 75KW (101cv)..... ←

Max torque at 1600 rpm..... 324 Nm..... 389 Nm..... ←

Capacities

Engine oil capacity..... 15L..... ←

Engine cooling system..... 17.7 L..... ←

Capacity of the radiator only..... 6 L..... ←

Fuel tank..... 250 L..... ←

Hydraulic fluid reservoir capacity..... 73 L..... ←

Total hydraulic system capacity..... 123 L..... 148 L..... ←

Capacity of the cooler only..... 7 L..... ←

Travel reduction gear housing capacity..... 3 L..... ←

Swing drive housing capacity..... 2.2 L..... 5 L..... ←

Idler wheel capacity..... 160cm³..... 180cm³..... ←

Upper roller capacity..... 35 to 40 cm³..... 50 to 55 cm³..... ←

Lower roller capacity..... 190 cm³..... 210 cm³..... ←

NOTE: *These capacities are only provided in an indicative manner. To check fluid levels, always use the oil dipstick, sight glasses or the filler cap.*

Electrical system

Type of system..... 24 volts negative earth

Alternator amperage..... 50 A

Battery

Number of batteries required..... 2

Voltage of each battery..... 12 volts

Capacity..... 120 Ah

Reserve..... 160 min

Cold starting capacity at -17°C..... 800 A

Load for load checking..... 400 A

Starter motor

Voltage..... 24 volts

Power..... 4.5 kW

Voltage regulator..... integrated, not adjustable

Hydraulic system

Main hydraulic pump

Double, axial piston, variable flow pump.

Max flow	2x123 l/min	2x137 l/min	←
Displacement.....	2x57.6 cm ³	2x64 cm ³	←

Hydraulic pilot pump

Fixed flow pump.

Max flow	23 l/min	22 l/min.....	←
Displacement.....	10.7 cm ³	←	←

Pressure settings

Pilot circuit secondary relief valve	39 ±1 bar.....	←	←
Main relief valve (standard)	343±3 bar	←	←
Main relief valve (higher pressure - 2-stage relief)	363±5 bar	←	←
Secondary relief valves (boom, dipper and bucket)	383±5 bar	←	←
Secondary relief valves (swing).....	279±4 bar	←	←
Secondary relief valves (travel)	430±5 bar	353±5 bar.....	←
Secondary relief valve (boom and dipper).....	383±5 bar	←	←

Cylinder

Boom cylinder

Barrel diameter	105 mm	115 mm.....	←
Rod diameter	70 mm	80 mm	←
Stroke	990 mm	1179 mm	←

Dipper cylinder

Barrel diameter	115 mm	125 mm	←
Rod diameter	80 mm	90 mm	←
Stroke	1108 mm	1253 mm	←

Bucket cylinder

Barrel diameter	95 mm	105 mm	←
Rod diameter	65 mm	75 mm	←
Stroke	881 mm	985 mm	←

Leaks on the cylinder - attachment lowering (without load)

Boom cylinders (rod retracting)	≤ 3 mm/5 min	≤ 5 mm/5 min.....	←
Dipper cylinder (rod extension).....	≤ 5 mm/5 min	≤ 5 mm/5 min.....	←
Bucket cylinder (rod extension)	≤ 7 mm/5 min	≤ 7 mm/5 min.....	←
Full (at the end of the attachment)	≤ 200 mm/10 min.....	≤ 200 mm/10 min	←

Cylinder speeds (in mode S)

Boom raising (open bucket on the floor).....	3.6±0.6 sec.	3.8±0.6 sec.....	←
Boom lowering (open bucket).....	3.0±0.6 sec.	3.6±0.6 sec.....	←
Dipper extension.....	2.6±0.6 sec.	3.0±0.6 sec.....	←
Dipper retraction	3.2±0.6 sec.	3.6±0.6 sec.....	←
Bucket opening.....	2.3±0.6 sec.	2.4±0.6 sec.....	←
Bucket closing	3.6±0.6 sec.	4.2±0.6 sec.....	←

Control valve

Five section control valve for dipper, boom acceleration, swing, option and RH travel.

Four section control valve for dipper acceleration, bucket, boom and LH travel.

Load holding valve for boom and dipper.

CX130

CX160

CX180

Swing

Fixed flow, axial piston motor.

Automatic disc brake.

Upperstructure swing speed	13.4 rpm.....	11.4 rpm	←
Displacement.....	65 cm ³	151 cm ³	←
Work output	100 l/min	155 l/min	←
Reduction ratio	17.03	13.34	←
Braking torque.....	≥ 294 Nm.....	≥ 739 Nm.....	←
Minimum brake release pressure	29 bar	←	←
Acceptable hydraulic motor leakage.....	xx l/min.....	←	←

Travel

Two-speed, axial piston motor.

Automatic disc brake.

Slow speed	3.6 km/h.....	3.2 km/h	2,4 km/h
Fast speed.....	5.5 km/h.....	5,5 km/h	4 km/h
Incline that can be overcome.....	70% (35°).....	←	←
Tractive force	11 000 daN	11 300 daN.....	18340 daN
Displacement.....	52.7/34 cm ³	87/49 cm ³	162/95 cm ³
Work output	121 l/min	140 l/min.....	137 l/mn
Reduction ratio	72.....	57,5.....	43,2
Braking torque (excluding reducer)	145 Nm	135 Nm.....	483Nm
Number of turns at the sprockets (10 turns)			
Mode "S", fast speed	13.4±0.6 sec.	12.8±0.6 sec.	19.6±0.6 sec.
Mode "S", slow speed.....	20.6±0.7 sec.	21.9±0.7 sec.	33.4±0.7 sec.
Permitted deviation in travel over a distance of 20 m			
Mode "H", full speed	1 m	←	←
Acceptable hydraulic motor leakage.....	xx l/min.....	←	←

Undercarriage

One-piece undercarriage with welded components.

Lubricated rollers and idler wheels.

Grease type track tension.

Ground pressure

with 500 mm track pads.....	0.39 bar	0.47 bar	
with 600 mm track pads.....	0.33 bar	0.40 bar	0,41 bar
with 700 mm track pads.....	0.29 bar	0.33 bar	0,36 bar
With 800 mm track pads.....	X	X.....	0,33 bar
with rubber track pads	0.40 bar	X.....	X
Tracks tension	240 to 260mm	260 to 280mm....	280 to 300mm

Attachment

Break-out force	9740 daN	11 790 daN	←
Penetration force			
2.10 m dipper	8020 daN		
2.50 m dipper	6740 daN		
3.00 m dipper	5610 daN		
2.20 m dipper	X	9300 daN	←
2.70 m dipper	X	8010 daN	←
3.10 m dipper	X	7400 daN	←

Weight of components

Engine	361 kg	←	←
Hydraulic pump	90 kg	←	←
Attachment control valve	140 kg	←	←
Swing motor/reduction gear assembly	99 kg	221 kg	←
Travel motor/reduction gear assembly	204 kg	247 kg	308 kg
Boom cylinder	108 kg	157 kg	←
Dipper cylinder	157 kg	210 kg	←
Bucket cylinder	93 kg	117 kg	←
Counterweight	2300 kg	3330 kg	←
Cab	254 kg	←	←
Turnable bearing	188 kg	244 kg	263 kg
Upperstructure	5820 kg	6780 kg	7670kg
Hydraulic swivel	27 kg	←	31 kg
Undercarriage	3880 kg	5760 kg	6570 kg
Machine without attachment	9830 kg	12 540kg	14240 kg
Attachment	2140 kg	3030 kg	3070 kg
Boom	1200 kg	1470 kg	1780 kg
Dipper	542 kg	729 kg	805 kg
Radiator and cooler set	48 kg	←	←
Fuel tank	72 kg	←	←
Hydraulic tank	106 kg	←	←
Idler wheel	65 kg	82 kg	←
Upper roller	13 kg	17 kg	←
Lower roller	20 kg	36 kg	←
Shock absorber	63 kg	85 kg	126 kg
Track 500 mm	728 kg	1016 kg	
Track 600 mm	816 kg	1164 kg	1257 kg
Track 700 mm	970 kg	1374 kg	1460 kg
Track 800 mm	X	X	1593 kg

DIMENSIONS AND LIMIT OF WEAR AND TEAR OF THE TRACKS SET

Toothed wheel

Dimensions

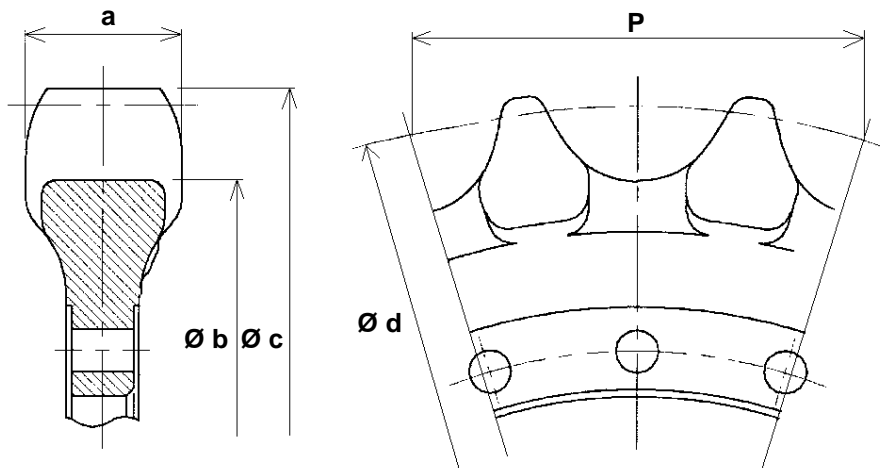

CS01B512

Marking	Dimension (mm)		
		CX130	CX160 CX180
a	Standard	59	66
	Limit	53	60
Ø b	Standard	584.48	582.5
	Limit	578.5	576.5
Ø c	Standard	652	659
	Limit	646	653
Ø d	Standard	635.48	644.6
	Limit	---	---
P	Standard	171.45	190
	Limit	---	---

Gauge

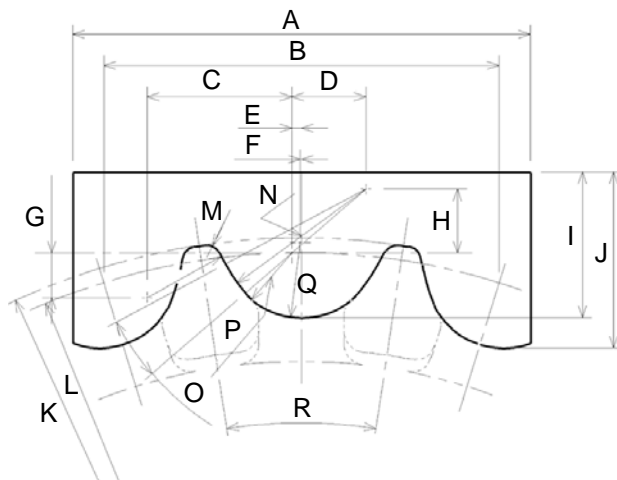

CS01D513

	CX130	CX160 CX180
A	200	220
B	171.5	190
C	60.48	69.58
D	31	35.61
E	4.23	4.6
F	---	0.52
G	17	21.46
H	26.2	30.6
I	60	70
J	72.9	84.7
K	Ø 652	R329.5
L	PDC 635.48	PDC 322.3
M	R4	R6
N	R66	R76.5
O	---	12.7°
P	R25.5	R29.6
Q	---	R36
R	15.7°	17.1°

Idler wheel

Dimensions

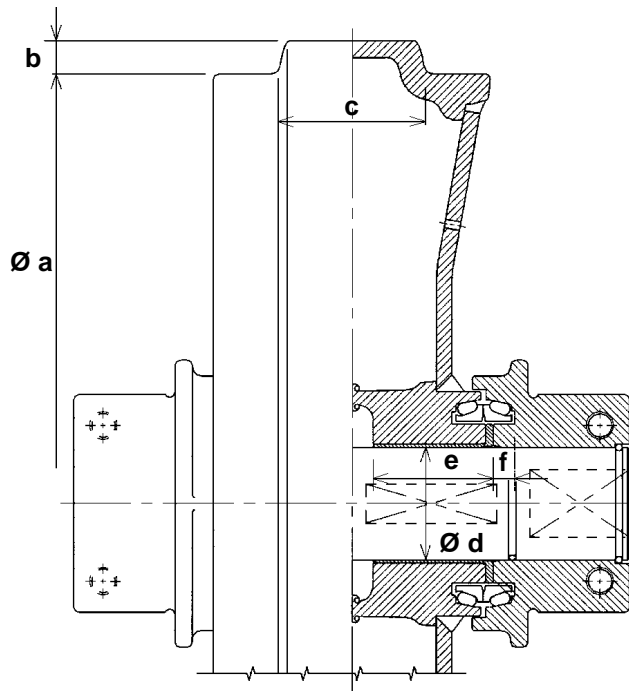

Marking		Dimension (mm)	
		CX130	CX160 CX180
$\varnothing a$	Standard	510	494
	Limit	506	490
b	Standard	17.5	19
	Limit	---	---
c	Standard	68	84
	Limit	64	80
$\varnothing d$ (rod)	Standard	55	65
	Limit	54.5	64.5
$\varnothing d$ (ring)	Standard	55	65
	Limit	55.8	65.8
e	Standard	55	69
	Limit	54.6	68.6
f	Standard	19.9	12.4
	Limit	19.4	11.9

CS01B514

Gauge

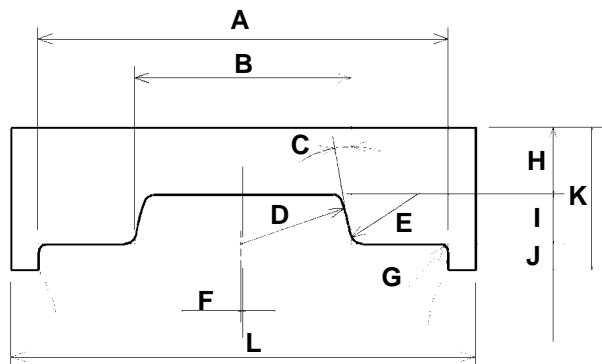

	CX130	CX160 CX180
A	135	159
B	68	84
C	10°	10°
D	R37	R42
E	2-R4	2-R5
F	3.6	0.6
G	4-R3	4-R3
H	26.5	26
I	17.5	19
J	11	10
K	55	55
L	160	180

CS01D514

Upper roller

Dimensions

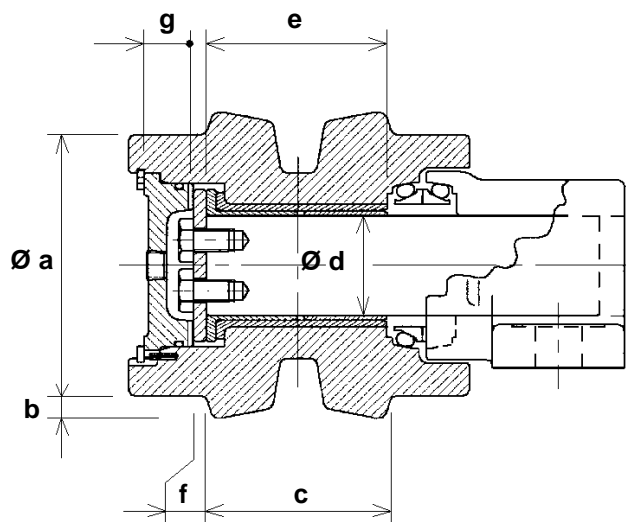

CS01B516

Marking		Dimension (mm)	
		CX130	CX160 CX180
Ø a	Standard	120	120
	Limit	112	112
b	Standard	10	10
	Limit	---	---
c	Standard	68	85
	Limit	62	79
Ø d (rod)	Standard	40	46
	Limit	39.5	45.5
Ø d (ring)	Standard	40	46
	Limit	40.8	46.8
e	Standard	63	83
	Limit	62.6	82.6
f	Standard	5.5	5.5
	Limit	5	5
g	Standard	22.5	22.5
	Limit	22.5	22

Gauge

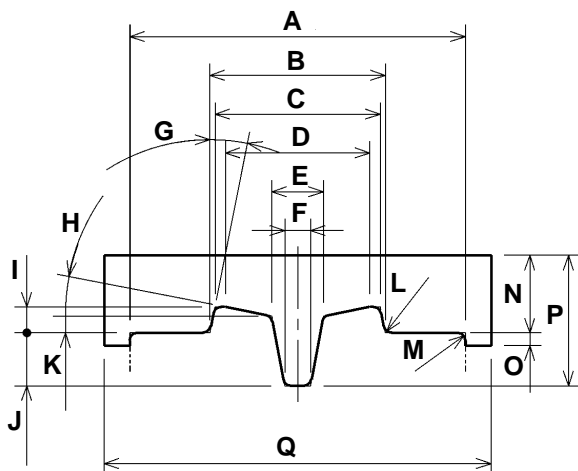

CS01D515

	CX130	CX160 CX180
A	130	156
B	68	85
C	64	78.6
D	56	68
E	20	24
F	10	16
G	11.3°	18°
H	11°	11.5°
I	10	10
J	20.5	17.5
K	6.5	5.5
L	R3	4-R3
M	R3	8-R3
N	30	35
O	5	10
P	50.5	45
Q	150	175

Lower roller

Dimensions

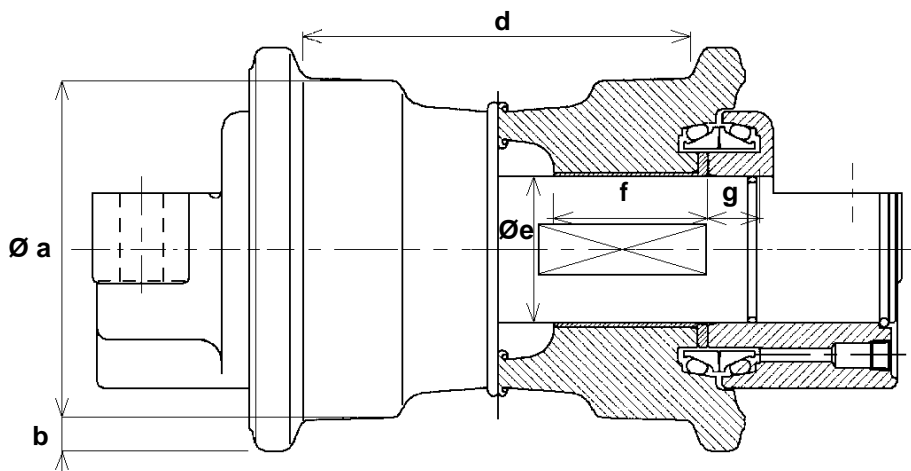

CS01B518

Marking	Dimension (mm)			Marking	Dimension (mm)		
		CX130	CX160 CX180			CX130	CX160 CX180
Ø a	Standard	130	150	Ø e (ring)	Standard	50	65
	Limit	122	142		Limit	50.8	65.8
b	Standard	15	15	f	Standard	53	69
	Limit	---	---		Limit	52.6	68.6
d	Standard	142	173	g	Standard	24.3	23.3
	Limit	148	179		Limit	23.8	22.8
Ø e (rod)	Standard	50	65				
	Limit	49.5	64.5				

Gauge

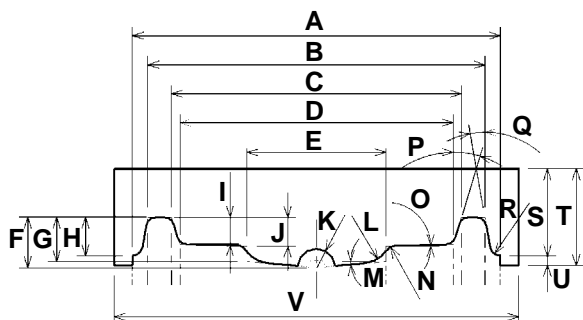

CS010D516

	CX130	CX160 CX180
A	191	221
B	175	215
C	150.6	184.7
D	142	173
E	72	84
F	26.1	29
G	23	25.3
H	20	10
I	14.1	13.8
J	15	15
K	R10	R10
L	R15	2-R10
M	5°	5°
N	6R5	6-R5
O	1.5°	1.5°
P	17°	23°
Q	10°	10°
R	4-R5	---
S	45	42
T	50	60
U	5	18
V	210	240

Track

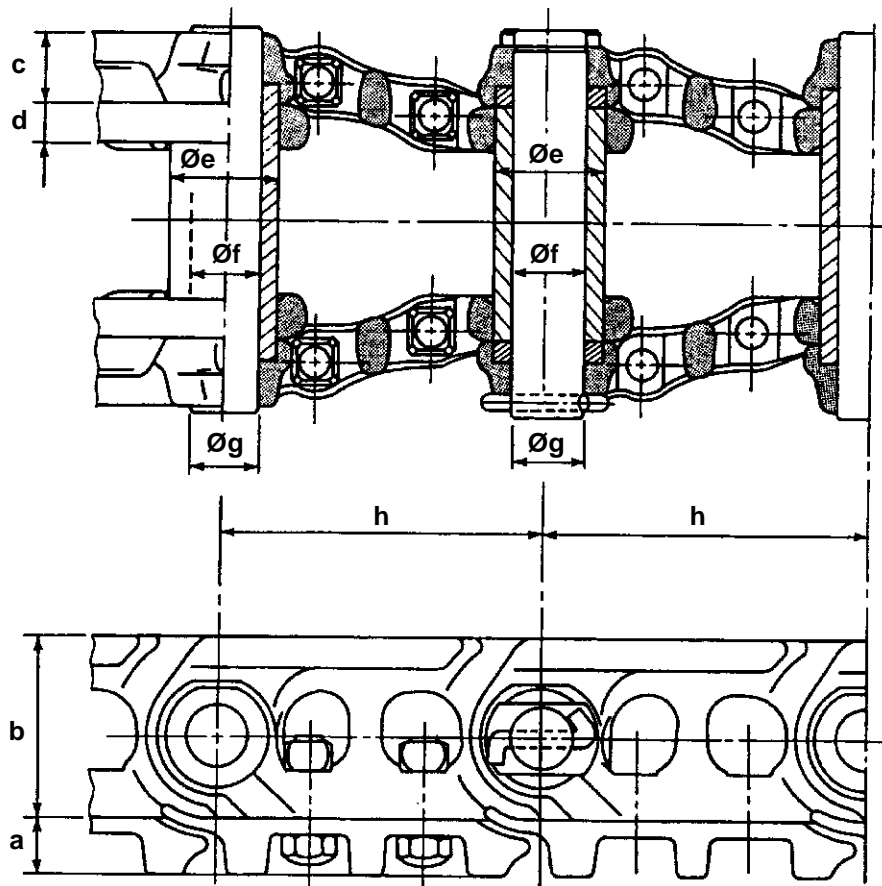

CS01B520

Marking		Dimension (mm)			Marking		Dimension (mm)		
		CX130	CX160	CX180			CX130	CX160	CX180
a	Standard	28	34.5		Ø e (ring)	Standard	50.6	58.72	
	Limit	18	21.5			Limit	49.5	57.5	
b	Standard	89	106		Ø f (ring)	Standard	34.1	37.3	
	Limit	84	101			Limit	35	38.3	
c	Standard	17	37.985		Ø g (rod)	Standard	33.25	36.3	
	Limit	15	36			Limit	32.5	35.5	
d	Standard	10.7	17.95		h	Standard	171.45	190	
	Limit	9	16			Limit	175	195	

DIMENSIONS AND LIMIT OF WEAR AND TEAR OF THE MOBILE JOINTS OF THE ATTACHMENT

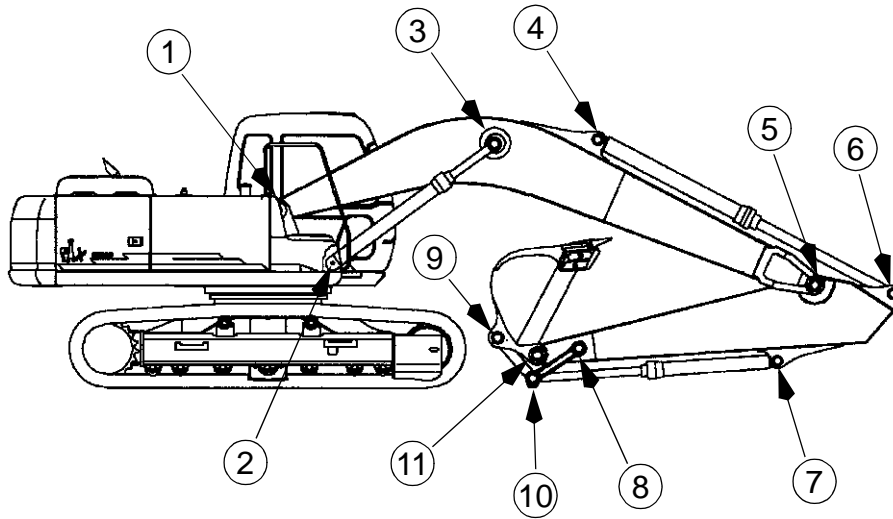

CS01B521

1. Boom foot/Undercarriage

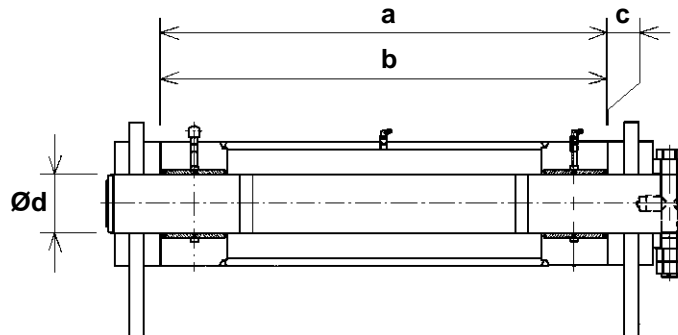

CS01B522

Marking	Dimension (mm)		
		CX130	CX160 CX180
a	Standard	569	632
	Limit	579	642
b	Standard	568.5	631
	Limit	566.5	629
c (a - b)	Standard	0.5 to 3	0.5 à 3
	Limit	Shims	Shims
Ø d (pin)	Standard	75	80
	Limit	76.5	79
Ø d (ring)	Standard	75	80
	Limit	74	81.5

2. Boom cylinder foot/Undercarriage

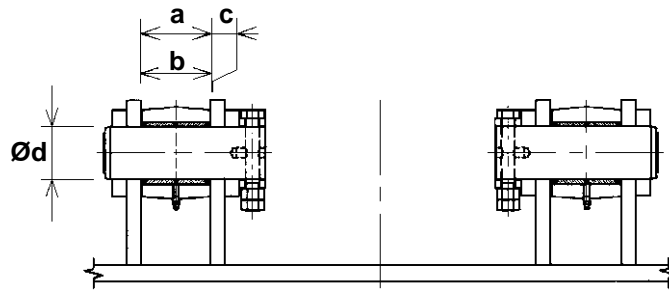

CS01B523

Marking		Dimension (mm)	
		CX130	CX160 CX180
a	Standard	83.5	111
	Limit	89.5	117
b	Standard	82.5	110
	Limit	80.5	108
c (play)	Standard	1 to 2.5	1 to 2.5
	Limit	Shims	Shims
Ø d (pin)	Standard	70	70
	Limit	69	69
Ø d (ring)	Standard	70	70
	Limit	71.5	71.5

3. Boom cylinder head/Boom

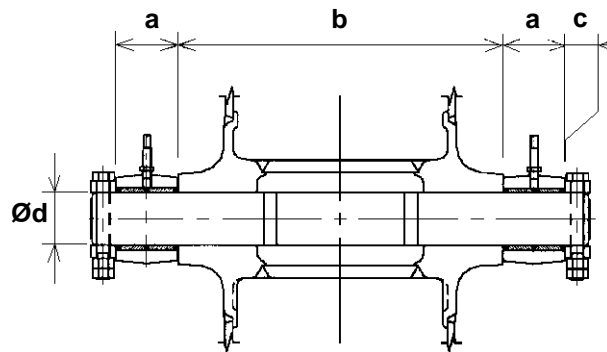

CS01B524

Marking		Dimension (mm)	
		CX130	CX160 CX180
a	Standard	92	100
	Limit	90	98
b	Standard	437	470
	Limit	431	464
c (play)	Standard	1 to 2.5	1 to 2.5
	Limit	Shims	Shims
Ø d (pin)	Standard	70	80
	Limit	69	79
Ø d (ring)	Standard	70	80
	Limit	71.5	81.5

4. Dipper cylinder foot/Boom

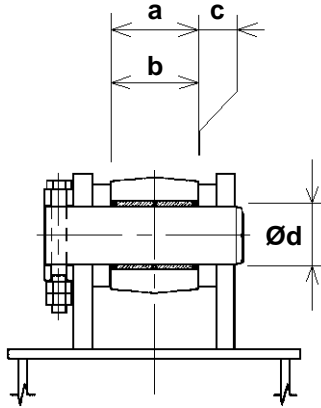

CS01B525

Marking		Dimension (mm)	
		CX130	CX160 CX180
a	Standard	99	111
	Limit	105	117
b	Standard	98	110
	Limit	96	108
c (a - b)	Standard	0.5 to 2	0.5 to 2
	Limit	Shims	Shims
Ø d (pin)	Standard	70	80
	Limit	69	79
Ø d (ring)	Standard	70	80
	Limit	71.5	81.5

5. Boom/Dipper

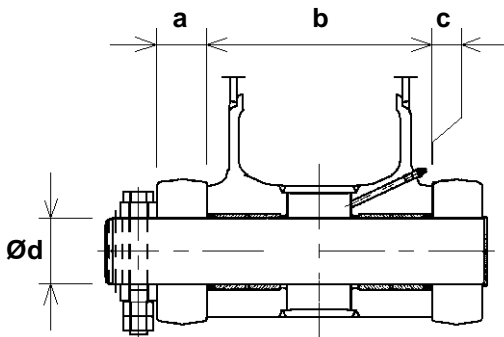

CS01B526

Marking		Dimension (mm)	
		CX130	CX160 CX180
a	Standard	259	275
	Limit	262	278
b	Standard	258.5	274.5
	Limit	256.5	272.5
c (play)	Standard	0.5 to 1.1	0.5 to 1.1
	Limit	Shims	Shims
Ø d (pin)	Standard	75	80
	Limit	74	79
Ø d (dipper)	Standard	75	80
	Limit	76.5	81.5
Ø d (boom)	Standard	75	80
	Limit	76.5	81.5

6. Dipper cylinder head/Dipper

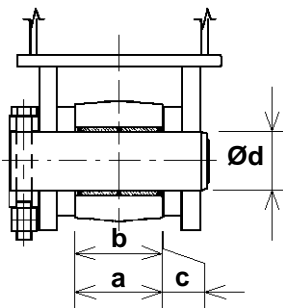

CS01B527

Marking		Dimension (mm)	
		CX130	CX160 CX180
a	Standard	96.5	111
	Limit	102.5	117
b	Standard	95.5	110
	Limit	92.5	108
c (a - b)	Standard	0.5 to 3	0.5 to 3
	Limit	Shims	Shims
Ø d (pin)	Standard	70	80
	Limit	69	79
Ø d (ring)	Standard	70	80
	Limit	71.5	81.5

7. Bucket cylinder foot/Dipper

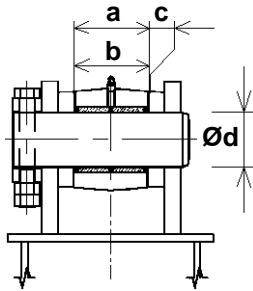

CS01B528

Marking		Dimension (mm)	
		CX130	CX160 CX180
a	Standard	88	101
	Limit	94	107
b	Standard	87	100
	Limit	85	98
c (a - b)	Standard	0.5 to 3	0.5 to 3
	Limit	Shims	Shims
Ø d (pin)	Standard	65	65
	Limit	64	64
Ø d (ring)	Standard	65	65
	Limit	66.5	66.5

8. Connecting rod/Dipper

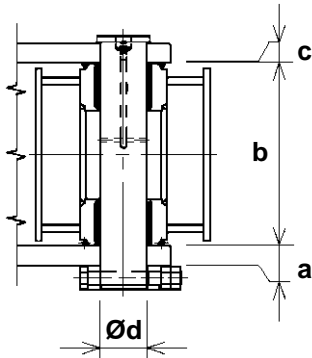

CS01B529

Marking		Dimension (mm)	
		CX130	CX160 CX180
a	Standard	32	32
	Limit	30	30
b	Standard	254	260
	Limit	252	258
c (play)	Standard	1 to 1.5	1 to 1.5
	Limit	Shims	Shims
Ø d (pin)	Standard	65	65
	Limit	64	64
Ø d (ring)	Standard	65	65
	Limit	66.5	66.5

9. Compensator/Bucket

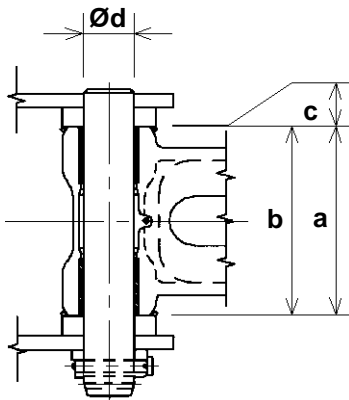

CS01B530

Marking		Dimension (mm)	
		CX130	CX160 CX180
a	Standard	255	301
	Limit	261	317
b	Standard	254	300
	Limit	252	298
c (play)	Standard	1 to 3.5	1 to 3.5
	Limit	Shims	Shims
Ø d (pin)	Standard	65	65
	Limit	64	64
Ø d (ring)	Standard	65	65
	Limit	66.5	66.5

10. Connecting rod/Compensator/Bucket cylinder head

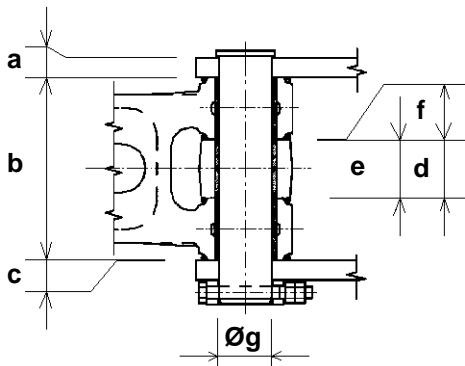

CS01B531

Marking		Dimension (mm)	
		CX130	CX160 CX180
a	Standard	32	32
	Limit	30	30
b	Standard	254	260
	Limit	252	258
c (play)	Standard	1 to 1.5	1 to 1.5
	Limit	Shims	Shims
d	Standard	92	86
	Limit	94	88
e	Standard	91	85
	Limit	93	83
f (d - e)	Standard	0.5 to 2	0.5 to 2
	Limit	Shims	Shims
Ø g (pin)	Standard	70	75
	Limit	69	74
Ø g (compensator)	Standard	70	75
	Limit	71.5	76.5
Ø g (cylinder)	Standard	70	75
	Limit	71.5	76.5

11. Dipper/Bucket

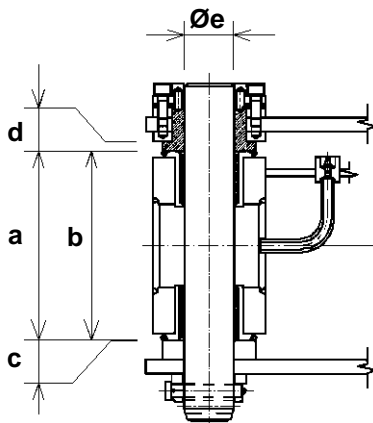

CS01B532

Marking		Dimension (mm)	
		CX130	CX160 CX180
a	Standard	255	301
	Limit	261	317
b	Standard	255	301
	Limit	253	299
c (a - b)	Standard	0 to 2.5	0 to 2.5
	Limit	Shims	Shims
d	Standard	16	16
	Limit	8	8
Ø e (pin)	Standard	65	80
	Limit	64	79
Ø e (dipper)	Standard	65	80
	Limit	66.5	81.5
Ø e (bucket)	Standard	65	80
	Limit	66.5	81.5

SPECIAL TORQUE SETTINGS

No.	Component	Screw (Ø)	Key (mm)	Torque setting (Nm)	
				CX130	CX160 CX180
1 *	Travel motor/reduction gear assembly	M16	24	267-312	
2 *	Sprocket	M16	24	267-312	
3 *	Idler wheel	M16	24	267-312	
4 *	Upper roller	M16	24	267-312	---
		M20	30	---	521-608
5 *	Lower roller	M16	24	267-312	---
		M18	27	---	371-432
6 *	Chain guide	M18	27	---	380-443
7	Track pad	M16	24	392-430	---
		M20	30	---	468-545
8	Counterweight	M27	41	844-980	1058-1235
9	Turntable (undercarriage)	M16	24	280-322	---
		M20	30	---	468-545
10	Turntable (upperstructure)	M16	24	280-322	---
		M20	30	---	468-545
11 *	Swing motor/reduction gear assembly	M16	24	280-322	---
		M20	30	---	521-608
12 *	Engine	M16	24	265-313	
13 *	Engine support	M10	17	64-73	
14	Radiator	M12	19	64-73	
15 *	Hydraulic pump	M10	17	63-72	
		M12		---	88-111
16 *	Hydraulic reservoir	M16	24	206-247	
17 *	Fuel tank	M16	24	206-247	
18 *	Control valve	M16	24	267-312	
		M12	19	88-107	---
19 *	Hydraulic swivel	M12	19	109-127	
20	Cab	M16	24	78-80	
21	Battery	M10	17	20-29	

NOTE: Use Loctite 262 or an equivalent on retaining screws of components marked with an asterisk (*).

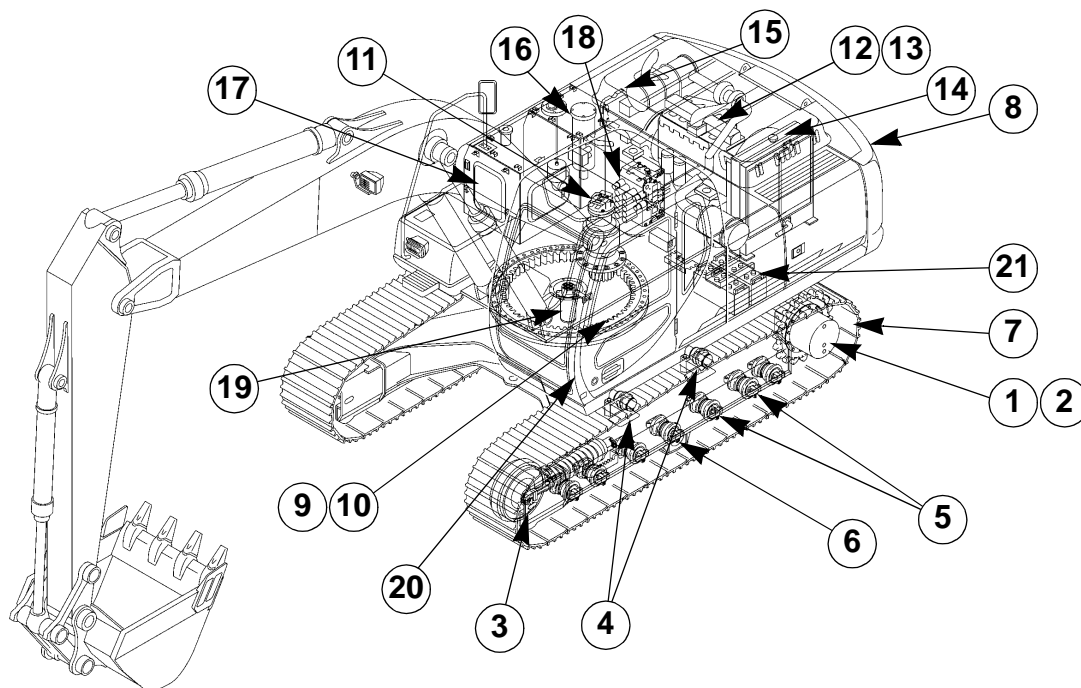

CS00E507

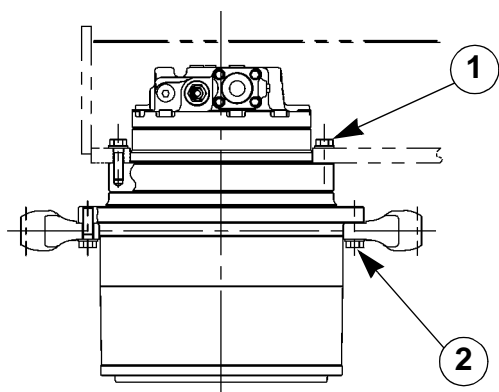

CS00E508

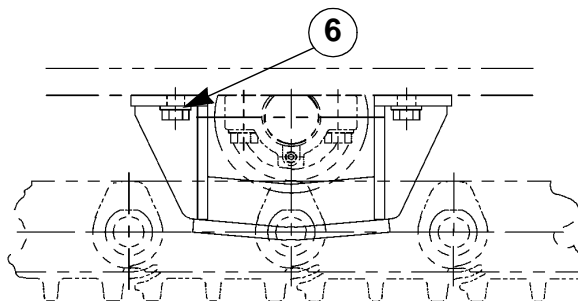

CS00E509

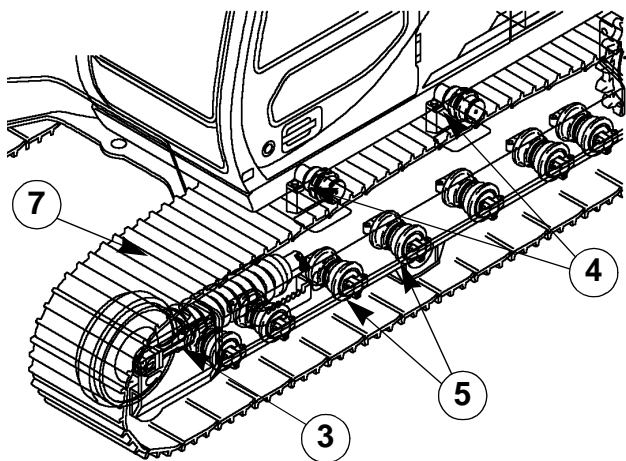

CS00E510

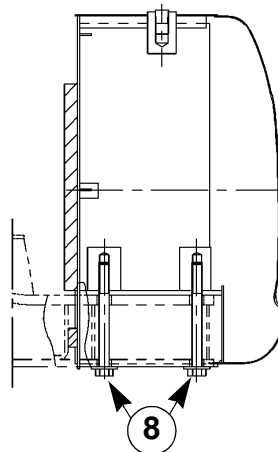

CS00E511

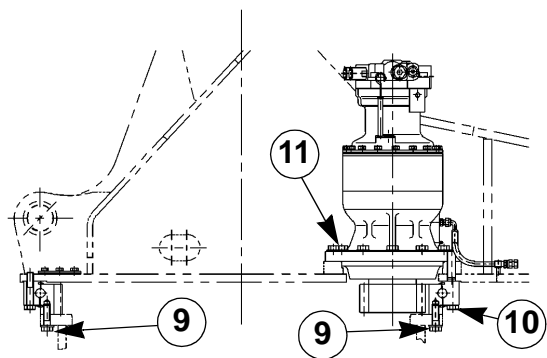

CS00E512

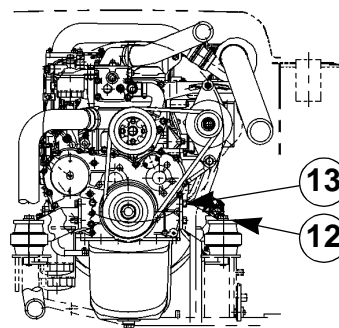

CS00E513

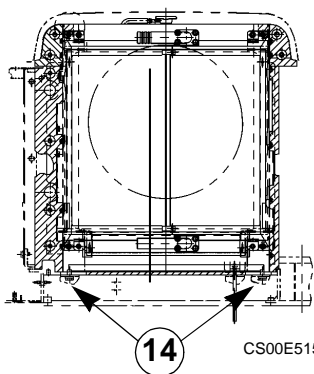

CS00E515

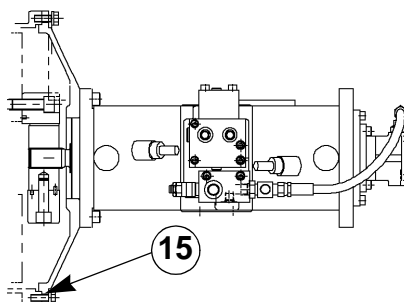

CS00E516

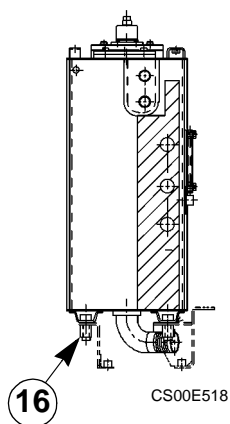

CS00E518

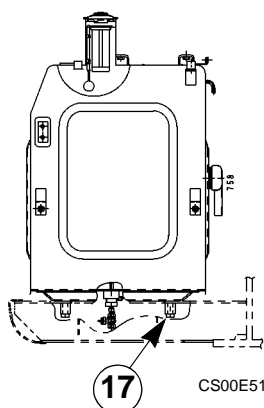

CS00E519

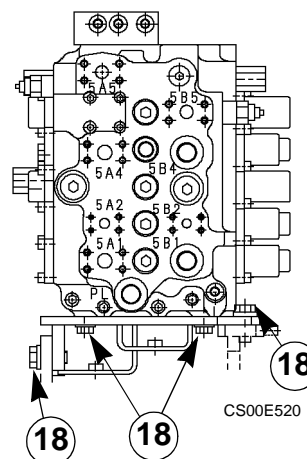

CS00E520

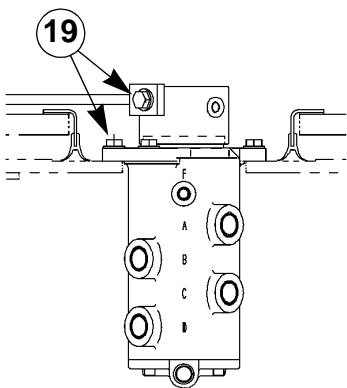

CS00E522

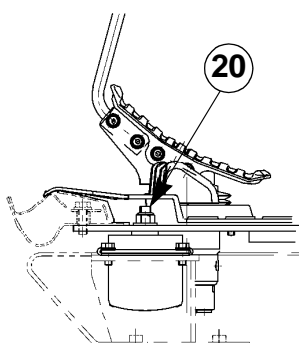

CS00E523

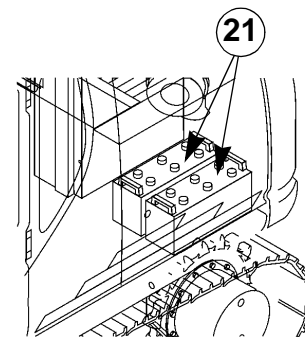

CS00E524

MACHINE OVERALL DIMENSIONS CX130 CX160

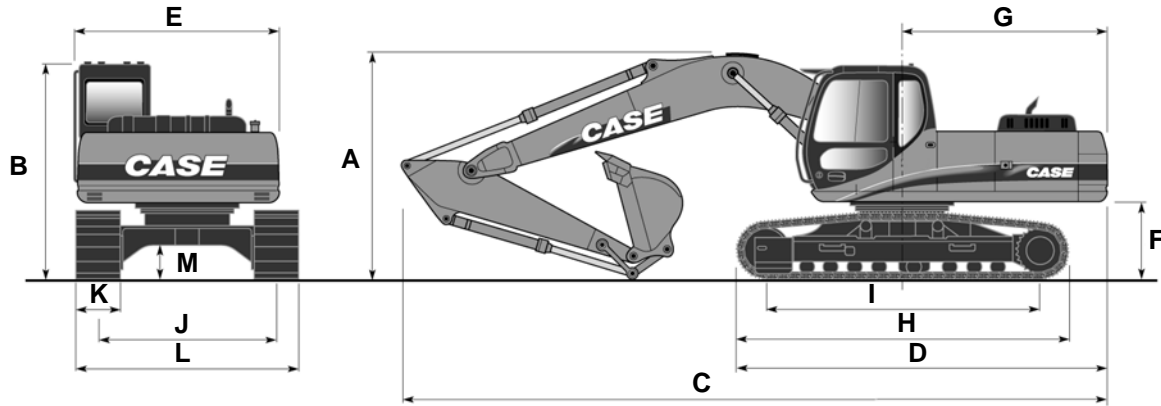

CS01B533

Only on CX130 machines with 3 m dipper

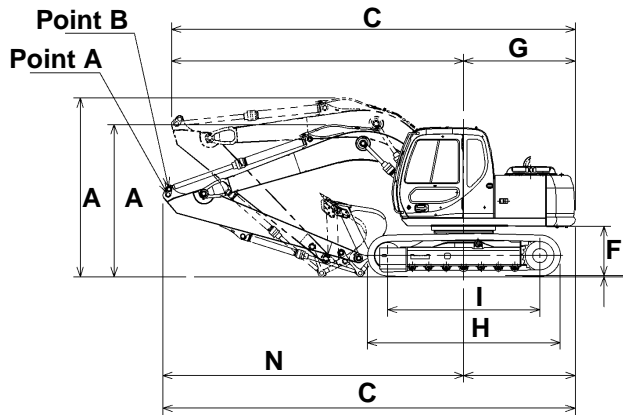

CS00E527

Point A: Working position
Point B: Transport position

IMPORTANT: For the transport of CX130 machines with 3 m dipper, it is imperative that the dipper cylinder head/dipper linkage is positioned at point B.

NOTE: Never work with the pin in this position.



WARNING: When the dipper cylinder is placed in position B (transport), take care not to damage the cab, there can be interference between the bucket and the cab.

	CX130				CX160		
	Dippers				Dippers		
	2.10 m	2.50 m	3.00 m (A)	3.00 m (B)	2.20 m	2.70 m	3.10 m
A.....	2.74 m	2.74 m	3.26 m	2.78 m		2.92 m	3.09 m
B.....	2.74 m	2.74 m	2.74 m	2.74 m	2.88 m	2.88 m	2.88 m
C.....	7.49 m	7.49 m	7.38 m	7.54 m		8.40 m	8.44 m
D.....	3.81 m	3.81 m	3.81 m	3.81 m	4.32 m	4.32 m	4.32 m
E.....	2.52 m	2.52 m	2.52 m	2.52 m	2.54 m	2.54 m	2.54 m
F.....	0.89 m	0.89 m	0.89 m	0.89 m	1.02 m	1.02 m	1.02 m
G.....	2.05 m	2.05 m	2.05 m	2.05 m	2.37 m	2.37 m	2.37 m
H.....	3.50 m	3.50 m	3.50 m	3.50 m	3.90 m	3.90 m	3.90 m
I.....	2.78 m	2.78 m	2.78 m	2.78 m	3.09 m	3.09 m	3.09 m
J.....	1.99 m	1.99 m	1.99 m	1.99 m	1.99 m	1.99 m	1.99 m
K (standard track pads).....	0.60 m	0.60 m	0.60 m	0.60 m	0.60 m	0.60 m	0.60 m
L (with 500 mm track pads).....	2.49 m	2.49 m	2.49 m	2.49 m	2.49 m	2.49 m	2.49 m
L (with 600 mm track pads).....	2.59 m	2.59 m	2.59 m	2.59 m	2.59 m	2.59 m	2.59 m
L (with 700 mm track pads).....	2.69 m	2.69 m	2.69 m	2.69 m	2.69 m	2.69 m	2.69 m
M.....	0.44 m	0.44 m	0.44 m	0.44 m	0.44 m	0.44 m	0.44 m
N.....	5.44 m	5.44 m	5.34 m	5.50 m		6.03 m	6.07 m

MACHINE OVERALL DIMENSIONS CX180

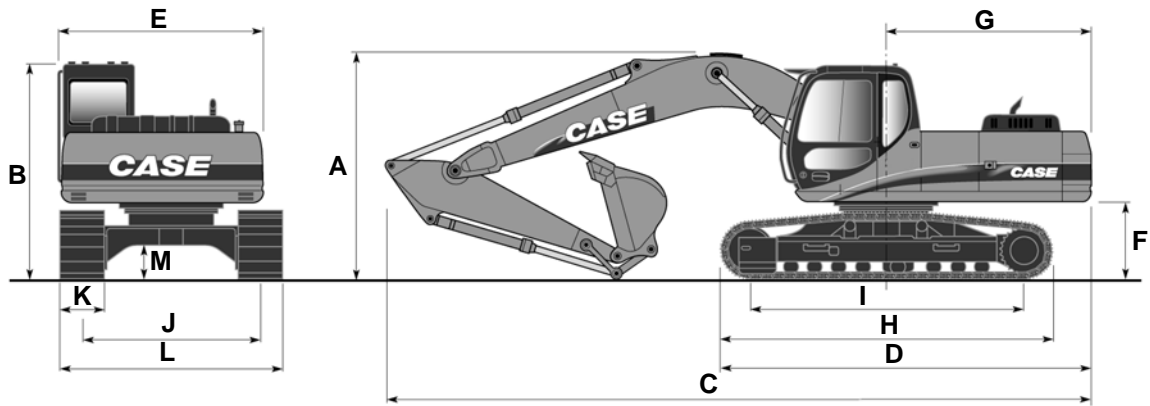

CS01B533

	CX180		
	Dippers		
	2.20 m	2.70 m	3.05 m (A)
A	2.53 m	2.92 m	3.09 m
B	2.89 m	2.89 m	2.89 m
C	8.41 m	8.39 m	8.44 m
D	4.45 m	4.45 m	4.45 m
E	2.54 m	2.54 m	2.54 m
F	1.04 m	1.04 m	1.04 m
G	2.37 m	2.37 m	2.37 m
H	4.15 m	4.15 m	4.15 m
I	3.37 m	3.37 m	3.37 m
J	2.20 m	2.20 m	2.20 m
K (standard track pads)	0.60 m	0.60 m	0.60 m
L (with 500 mm track pads)	2.80 m	2.80 m	2.80 m
L (with 600 mm track pads)	2.90 m	2.90 m	2.90 m
L (with 700 mm track pads)	3.00 m	3.00 m	3.00 m
M	0.46 m	0.46 m	0.46 m

Section

2000

REMOVAL AND INSTALLATION OF THE ENGINE

TABLE OF CONTENTS

SPECIFICATIONS..... 2

SPECIAL TORQUE SETTINGS 2

ENGINE..... 3

 Removal and installation 3

SPECIFICATIONS

Weight of engine..... See Section 1002

SPECIAL TORQUE SETTINGS

Engine retaining screws See Section 1002

ENGINE

Removal and installation

STEP 1

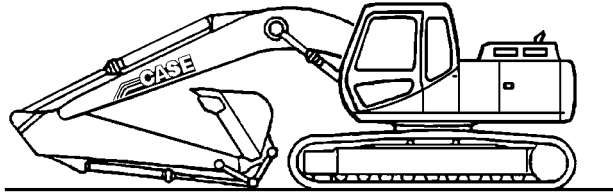

JS00163A

Park the machine on hard, flat ground. Lower the attachment to the ground.

STEP 2

Release pressure in the hydraulic system and in the hydraulic reservoir (see Section 8000).

STEP 3

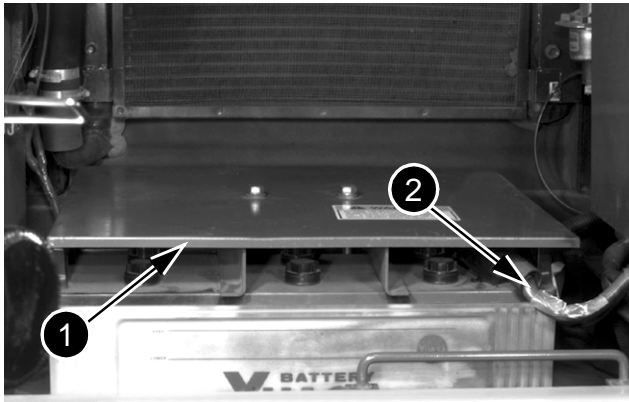

JD00375A

Remove the battery cover (1) and disconnect the earth cable (-) (2) from the battery.

STEP 4

Refer to Section 8003 and remove the hydraulic pump.

STEP 5

Refer to Section 2001 and remove the radiator and oil-cleaner assembly.

STEP 6

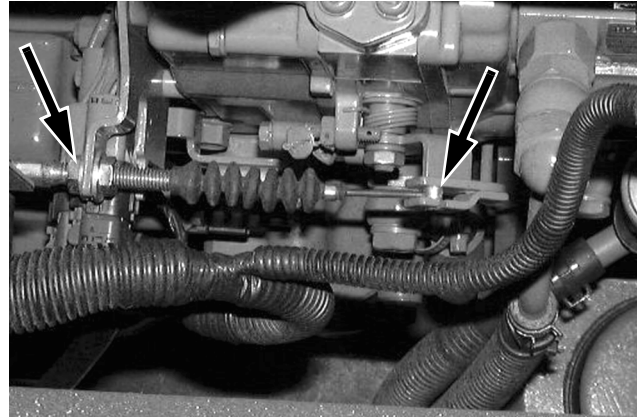

CD00J024

Remove the engine throttle control.

STEP 7

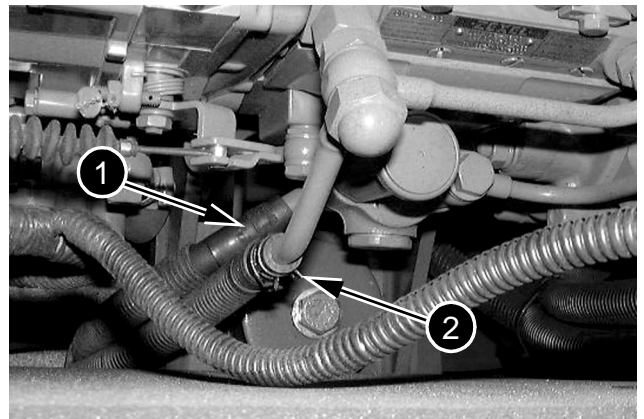

CD00J025

Disconnect the fuel supply pipe (1) and the fuel return pipe (2) and plug them.

STEP 8

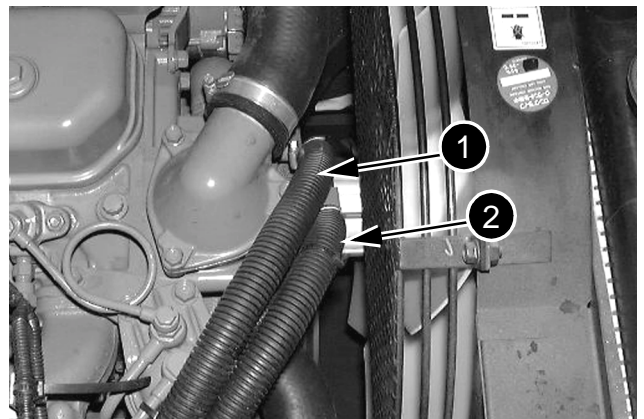

CD00J026

Remove the hoses (1) and (2) from the heater system and plug them.

STEP 9

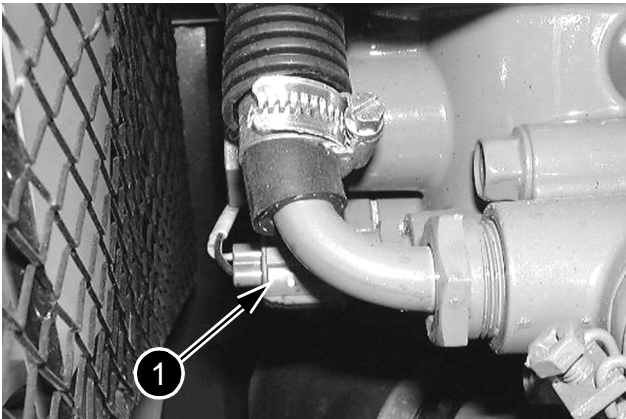

CD00J027

Label and disconnect the electrical connection from the water temperature sensor (1).

STEP 10

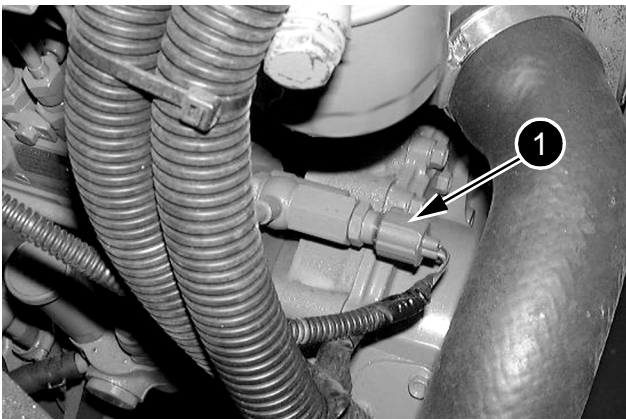

CD00J028

Label and disconnect the electrical connection from the fuel temperature sensor (1).

STEP 11

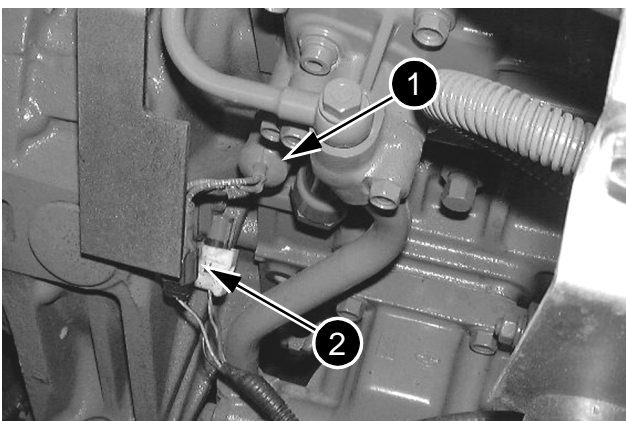

CD00J029

Label and disconnect the electrical connection from the oil pressure detector (1) and the engine speed detector (2).

STEP 12

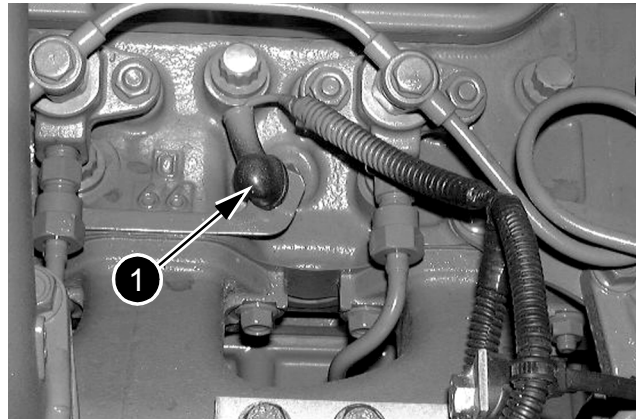

CD00J030

Label and disconnect the electrical supply (1) to the pre-heating plugs.

STEP 13

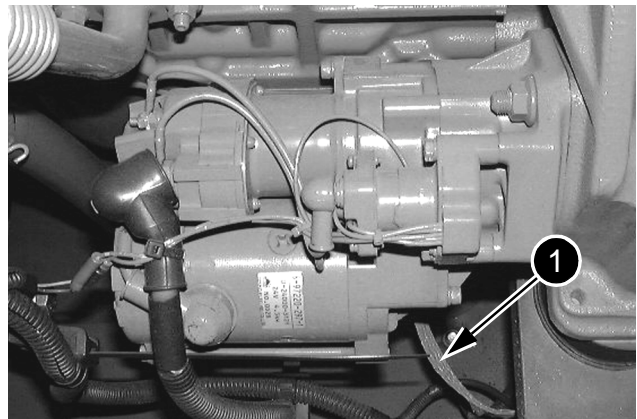

CD00J031

Label and disconnect the starter motor electrical connections. Remove the earth braid cable (1) at the engine end.

This as a preview PDF file from best-manuals.com



Download full PDF manual at best-manuals.com