

The CASE logo is displayed in a bold, white, sans-serif font. The letters 'C', 'A', and 'S' are connected, and the 'E' is slightly separated. Below the letters is a thick, horizontal orange bar.

PROFESSIONAL PARTNER

OPERATOR'S MANUAL WHEEL LOADER

721E
821E
TIER 3

87479861 NA
Replaces 87364251 NA

Issued 03-2008



OPERATOR'S MANUAL

WHEEL LOADER

721E
821E
TIER 3



READ, UNDERSTAND, AND FOLLOW ALL SAFETY
PRECAUTIONS AND INSTRUCTIONS FOUND IN THIS
MANUAL BEFORE OPERATING THE MACHINE.

CNH America LLC reserves the right to make improvements in design or changes in specifications at any time without incurring any obligation to install them on units previously sold.

All data given in this publication is subject to production variations. Dimensions and weights are only approximate. Illustrations do not necessarily show products in standard condition. For exact information about any particular product, please consult your Dealer.

| REVISION HISTORY | | | |
|------------------|------------|-------------------------------|-------------|
| Issue | Issue Date | Applicable Machines | Remarks |
| First Edition | 08-2006 | 721E-821E Tier 3 Wheel Loader | 87364251 NA |
| Revision 1 | 03-2008 | 721E-821E Tier 3 Wheel Loader | 87479861 NA |







THIS SAFETY ALERT SYMBOL INDICATES IMPORTANT SAFETY MESSAGES IN THIS MANUAL. WHEN YOU SEE THIS SYMBOL, CAREFULLY READ THE MESSAGE THAT FOLLOWS AND BE ALERT TO THE POSSIBILITY OF DEATH OR SERIOUS INJURY.

Safety Decals on this machine use the words Danger, Warning, or Caution, which are defined as follows:

- **DANGER:** Indicates an immediate hazardous situation that, if not avoided, will result in death or serious injury. The color associated with Danger is RED.
- **WARNING:** Indicates a potentially hazardous situation that, if not avoided, could result in death or serious injury. The color associated with Warning is ORANGE.
- **CAUTION:** Indicates a potentially hazardous situation which, if not avoided, may result in minor or moderate injury. It may also be used to alert against unsafe practices. The color associated with Caution is YELLOW.

If Safety Decals on this machine are ISO two panel Pictorial, decals are defined as follows:

- The first panel indicates the nature of the hazard.
- The second panel indicates the appropriate avoidance of the hazard.
- Background color is YELLOW
- Prohibition symbols such as  and  and  if used, are RED.



WARNING

IMPROPER OPERATION OF THIS MACHINE CAN CAUSE DEATH OR SERIOUS INJURY. BEFORE USING THIS MACHINE, MAKE CERTAIN THAT EVERY OPERATOR:

- ② Is instructed in safe and proper use of the machine.
- ② Reads and understands the Manual(s) pertaining to the machine.
- ② Reads and understands ALL Safety Decals on the machine.
- ② Clears the area of other persons.
- ② Learns and practices safe use of machine controls in a safe, clear area before operating this machine on a job site.

It is your responsibility to observe pertinent laws and regulations and follow instructions on machine operation and maintenance.

CALIFORNIA PROPOSITION 65 WARNING

Diesel engine exhaust and some of its constituents are known to the State of California to cause cancer, birth defects, and other reproductive harm.

Battery post, terminals and related accessories contain lead and lead compounds. Wash hands after handling.

TECHNICAL MANUALS

Manuals are available from your Dealer for the operation, service, and repair of your machine. Contact your Dealer for assistance in obtaining the manuals for your machine. Your Dealer can expedite your order for Operator's Manuals, Parts Catalogs, Service Manuals, and maintenance records. Always give the Machine Name, Model, and P. I. N. (Product Identification Number) or S. N. (Serial Number) of your machine so your Dealer can provide the correct manuals for your machine.

TABLE OF CONTENTS

CHAPTER 1

GENERAL INFORMATION

| | |
|--------------------------|-----|
| To the Owner | 1-1 |
| Machine Components | 1-5 |

CHAPTER 2

SAFETY, AND DECALS

| | |
|-------------------------|------|
| Table of Contents | 2-1 |
| Safety Rules | 2-3 |
| Personal Safety | 2-3 |
| Utility Safety | 2-4 |
| Decals | 2-11 |

CHAPTER 3

INSTRUMENTS AND CONTROLS

| | |
|-----------------------------------|------|
| Table of Contents | 3-1 |
| Access Doors and Covers | 3-3 |
| Cab | 3-5 |
| Front Console | 3-14 |
| Instrument Panel Indicators | 3-15 |
| Control Levers | 3-32 |
| Side Console | 3-37 |
| Climate Control | 3-38 |

CHAPTER 4

OPERATING INSTRUCTIONS

| | |
|-------------------------|------|
| Table of Contents | 4-1 |
| Control Levers | 4-13 |

CHAPTER 5

LUBRICATION, FILTERS, AND FLUIDS

| | |
|---|------|
| Table of Contents | 5-1 |
| Servicing Instructions | 5-3 |
| Support Strut for Loader Lift Arms | 5-4 |
| Releasing Pressure in the Hydraulic System | 5-5 |
| Fluids and Lubricants | 5-6 |
| Engine Oil Viscosity / Temperature Ranges | 5-7 |
| Daily Inspections | 5-10 |
| Lubrication and Maintenance Quick Reference Chart | 5-11 |
| Access Doors and Fill Locations | 5-12 |
| Scheduled Maintenance | 5-14 |

CHAPTER 6

MAINTENANCE AND ADJUSTMENTS

| | |
|-------------------------|------|
| Table of Contents | 6-1 |
| Cab Service | 6-20 |

CHAPTER 7

ELECTRICAL

| | |
|-------------------------|------|
| Table of Contents | 7-1 |
| Electrical System | 7-3 |
| Batteries | 7-5 |
| Fuses and Relays | 7-7 |
| Machine Lights | 7-10 |

CHAPTER 8

SPECIFICATIONS

| | |
|-------------------------|-----|
| Table of Contents | 8-1 |
| Specifications | 8-3 |
| 721E | 8-3 |
| Specifications | 8-7 |
| 821E | 8-7 |

CHAPTER 9

INDEX

Chapter 1
GENERAL INFORMATION
TO THE OWNER



BD06F164

Figure 1

721E

Read this manual before you start the engine or operate the machine. If you need more information, see your Case dealer.

With experienced and trained technicians, your Case dealer can provide the best methods of repair and maintenance for your machine. Your dealer can give you assistance with Case approved service parts.

Use this manual as a guide. Your Wheel Loader will remain a reliable working tool as long as it is kept in working condition and serviced properly.



BD06F005

Figure 2

721E XT

DO NOT OPERATE or permit anyone to operate or service this machine until you or the other persons have read and understand the safety, operation and maintenance instructions in this manual. Use only trained operators who have demonstrated the ability to operate and service this machine correctly and safely.

This Wheel Loader, with standard equipment and attachments is intended to be used for digging and general earth moving purposes such as land leveling, truck loading, and material rehandling. This machine is not intended to be used for lifting other objects or transporting loads at high speeds.



BD06F007

Figure 3

821E

DO NOT use this machine for any application or purpose other than those described in this manual. If the loader is to be used in an application that involves special attachments or equipment, such as forestry, etc., consult an authorized dealer. Consult an authorized dealer on changes, additions or modifications that can be required for this machine to comply with various country regulations and safety requirements. Unauthorized modifications may cause serious injury or death. Anyone making such unauthorized modifications is responsible for the consequences.

This Operators Manual is to be stored in the manual compartment equipped on this machine. Make sure this manual is complete and in good condition. Contact your dealer to obtain additional manuals. Contact your dealer for any further information or assistance about your machine.

Before permitting a new operator on this machine, make certain:

- That the operator has received the necessary training to operate the machine correctly and safely.
- That the operator has read and understands the instructions given in this manual.

Always keep this manual in the operator's compartment. Make sure it is always complete and in good condition. If you wish to obtain extra copies, or copies in languages other than that of the country of use, consult your dealer.

Your dealer is at your disposal for any further information. He will also provide any after-sales service you may require and genuine Case replacement parts, your guarantee of quality and match.



BD06F071

Figure 4

OPERATOR MANUAL STORAGE COMPARTMENT

To access the operator manual storage area located on the back of the operator's seat, release the latch on top of the seat and open the compartment.

READ THIS MANUAL COMPLETELY and make certain you understand the controls. All equipment has a limit. Make sure you understand the speed, brakes, steering, stability and load characteristics of this machine before you start to operate.

DO NOT remove this manual or the safety manual from the machine. See your dealer for additional manuals. Also see the manual information on the inside of the rear cover of this manual.

When you see this symbol read your Operator's Manual.



When you see this symbol refer to your Repair Manual.



RIGHT, LEFT, FRONT, AND REAR OF THE MACHINE

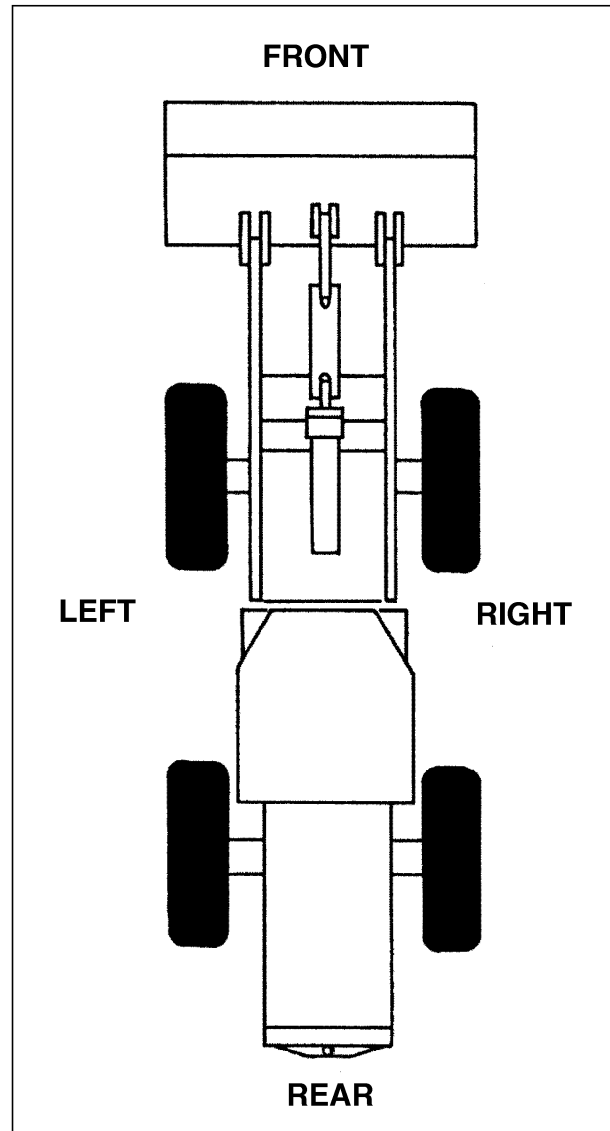

B891464

Figure 5

The terms Right-hand, Left-hand, Front, and Rear are used in this manual to indicate the sides as they are seen from the operator's seat.

MACHINE COMPONENTS

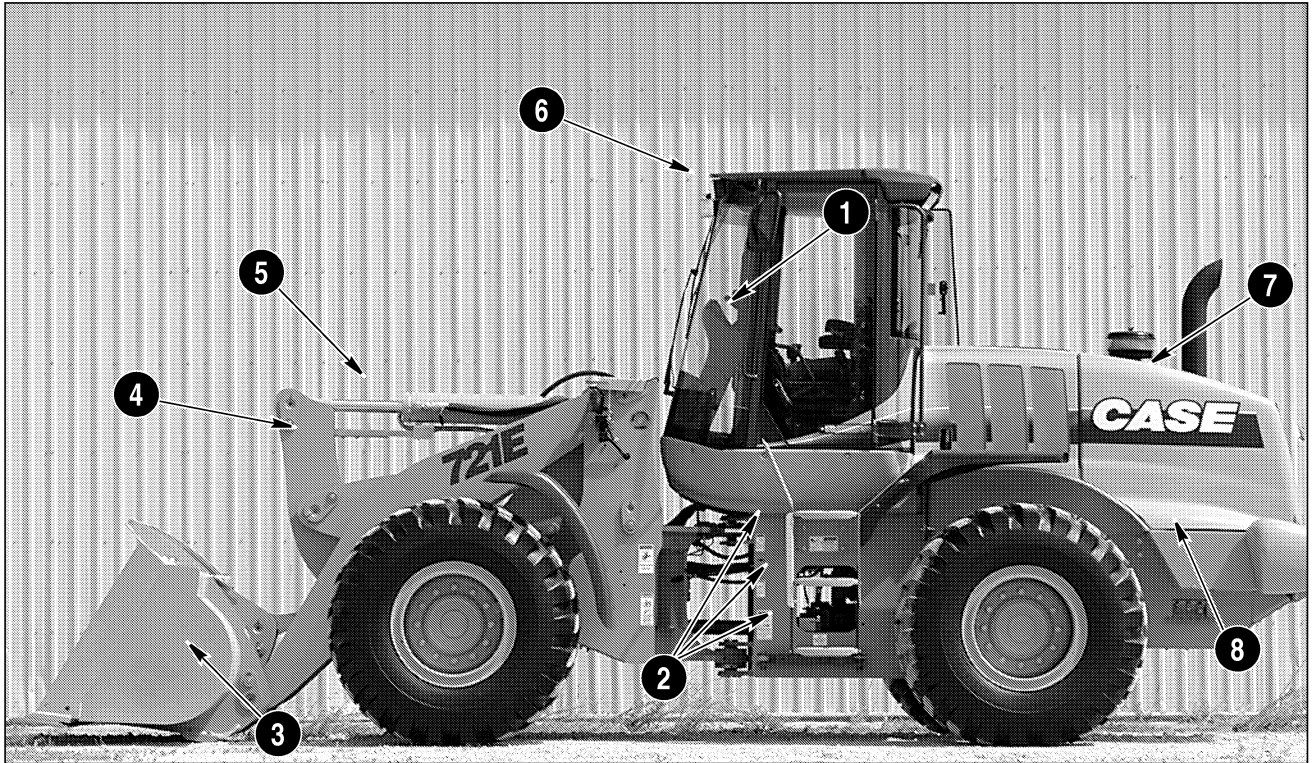

BD06F164

Figure 6

MACHINE COMPONENTS

- | | |
|----------------------------|------------------------|
| 1. CAB DOOR AND HAND HOLDS | 5. BUCKET CYLINDER |
| 2. STEPS | 6. ROPS CAB |
| 3. BUCKET | 7. ENGINE HOOD |
| 4. BELLCRANK | 8. LEFT BATTERY ACCESS |

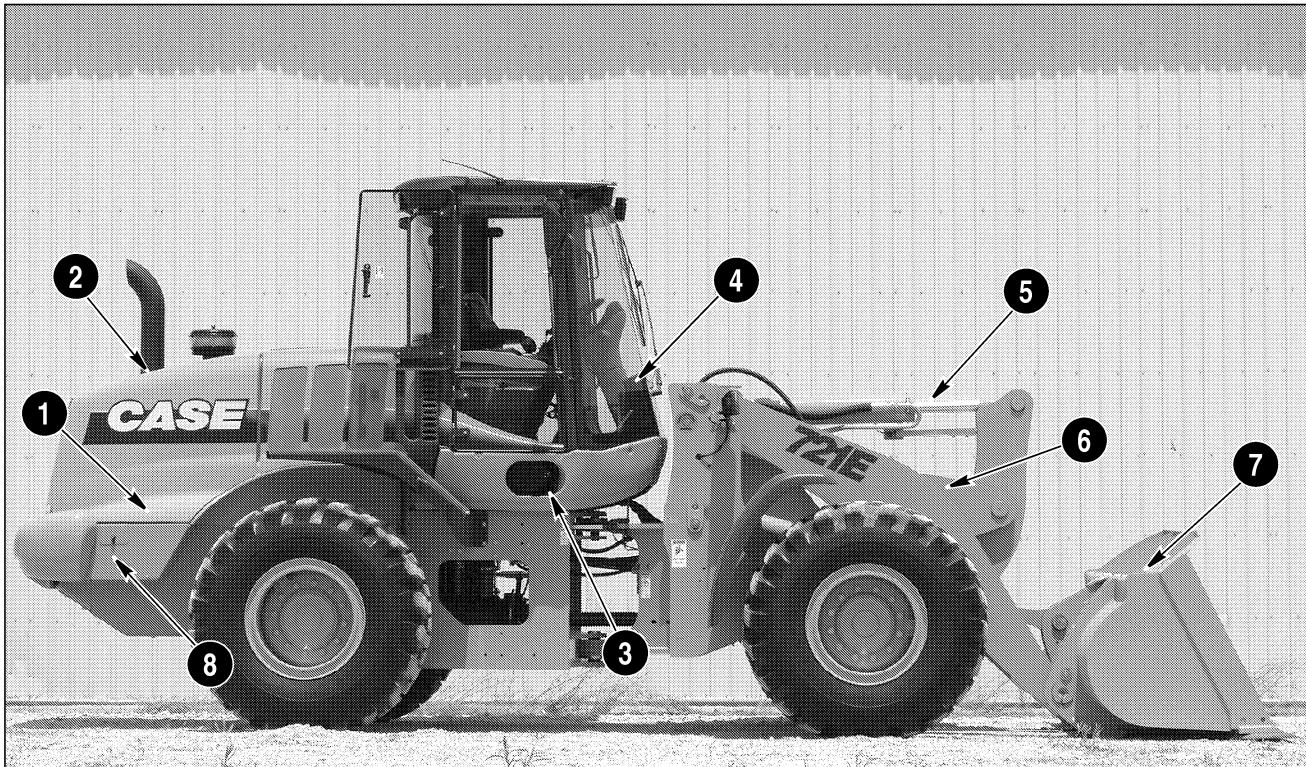

BD06F166

Figure 7

MACHINE COMPONENTS

- | | | |
|-----------------------------------|--------------------|--------------------------------------|
| 1. Right Side Battery Compartment | 4. Front Console | 7. Bucket |
| 2. Engine Hood | 5. Bucket Cylinder | 8. Hood Switch and Disconnect Switch |
| 3. Cab Air Filter Access | 6. Loader Lift Arm | |

**IDENTIFICATION NUMBERS
MODEL, SERIAL NUMBER, AND YEAR OF
MANUFACTURE**

When ordering parts, obtaining information or assistance, always supply your dealer with the type and serial number of your machine or accessories.

Write the following information in the spaces below: The type, serial number and year of manufacture of your machine, accessories and the serial numbers of the various hydraulic and mechanical components.

Make a record of the numbers and keep the record and your Manufacturer's Statement of Origin in a safe place.

| PRODUCT IDENTIFICATION PLATE | |
|------------------------------|--------------------------------|
| ➤ | _____ Model _____ |
| ➤ | _____ Serial Number _____ |
| ➤ | _____ Manufacturing Year _____ |

| ENGINE | |
|--------|----------------------------|
| ➤ | _____ Make and Model _____ |
| ➤ | _____ Serial Number _____ |

| COMPONENT SERIAL NUMBERS | |
|--------------------------|---------------------------------|
| ➤ | _____ Transmission _____ |
| ➤ | _____ Front and Rear Axle _____ |
| ➤ | _____ ROPS CAB _____ |

ROPS CAB

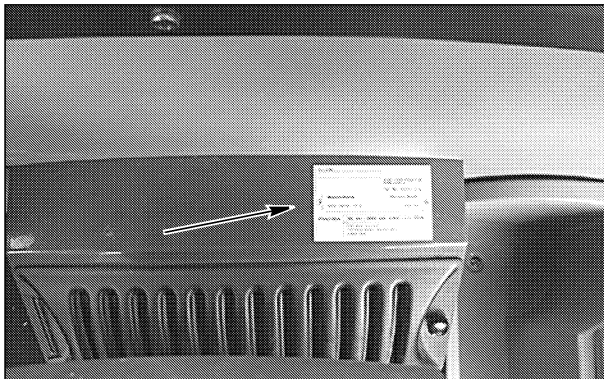

BD06H167

Figure 8

PRODUCT IDENTIFICATION NUMBER (P.I.N.)



BD06F166

Figure 9

ENGINE

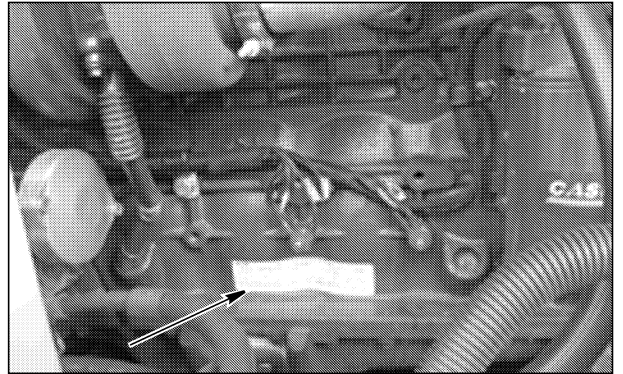

BD06F092

Figure 10

TRANSMISSION

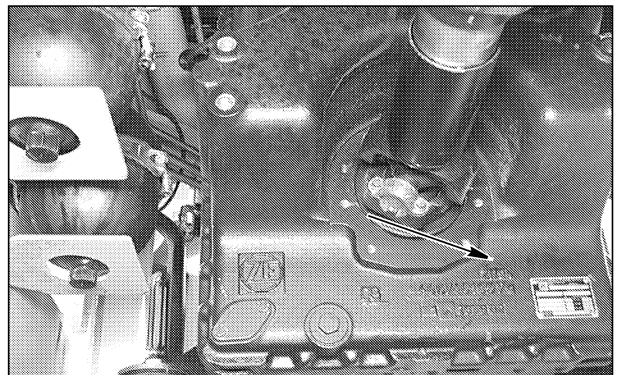

BD02N124

Figure 11

AXLE



BD02N126

Figure 12

NOTES

Chapter 2
SAFETY, AND DECALS
TABLE OF CONTENTS

SAFETY RULES 2-3

PERSONAL SAFETY 2-3

UTILITY SAFETY 2-4

 Personal 2-5

 General 2-5

 Mounting and Dismounting Precautions 2-5

 Starting and Stopping Precautions 2-5

 Operating Precautions 2-6

 Maintenance Precautions 2-7

 Fuel Handling Precautions 2-8

 Burn Prevention 2-8

 Hazardous Chemical Precautions 2-8

 Transporting Precautions 2-8

 Fire Extinguisher 2-8

 Seat Belt Precautions 2-9

 Specific Precautions to this Machine 2-10

DECALS 2-11

NOTES

SAFETY RULES



WARNING: This safety alert symbol indicates important safety messages in this manual. When you see this symbol, carefully read the message that follows and be alert to the possibility of death or serious injury.

M171C

Most accidents involving machine operation and maintenance can be avoided by following basic safety rules and precautions. Read and understand all the safety messages in this manual, the safety manual and the safety signs on the machine before you operate or service the machine. See your dealer if you have any questions.



BD06F071

Figure 1

OPERATOR'S MANUAL STORAGE SPACE

READ THIS MANUAL COMPLETELY and make sure you understand the controls. All equipment has a limit. Make sure you understand the speed, brakes, steering, stability, and load characteristics of the machine before you start to operate this machine.

DO NOT remove this manual or the safety manual from the machine. See your dealer for additional manuals. Also see the manual information on the Title pages (first and second pages in front of the Table of Contents) of this manual.

The safety information given in this manual does not replace safety codes, insurance needs, federal, state, or local laws. Make sure that your machine has the correct equipment according to these rules or laws.

Additional safety messages are used in the text of the manual to show specific safety hazards.

IMPORTANT: *The safety messages in this chapter point out conditions which can happen during the normal operation and maintenance of your machine. These safety messages also give possible ways of dealing with these conditions.*



PERSONAL SAFETY

Safety Decals on this machine may use the words, **Danger, Warning** or **Caution**, which are defined as follows:

- **DANGER:** Indicates an immediate hazardous situation which, if not avoided, will result in death or serious injury. The color associated with Danger is **RED**.
- **WARNING:** Indicates a potentially hazardous situation which, if not avoided will result in serious injury. The color associated with Warning is **ORANGE**.
- **CAUTION:** Indicates a potentially hazardous situation which, if not avoided, may result in minor or moderate injury. It may also be used to alert against unsafe practices. The color associated with Caution is **YELLOW**.

ISO two panel pictorial symbol decals, if used are defined as follows:

- The first panel indicates the nature of the hazard.
- The second panel indicates the appropriate avoidance of the hazard.
- Background color is **YELLOW**.

Prohibition symbols such as   and  if used, are **RED**.

UTILITY SAFETY

Safety precautions **MUST** be followed when working near buried and overhead utility lines.

During operation it is likely that you will be working around or near buried or overhead utility lines which may include, but are not limited to:

- Electrical Power Line
- Gas Line
- Water Line
- Communication Line - Telephone or Cable Television
- Sewer Line

IMPORTANT: *Before beginning any machine operation, it is your responsibility to be aware of all such utility lines buried and overhead in the area of your project and to avoid them.*

ALWAYS have all local utility companies mark the location of their lines.

In U.S.A. and Canada, call one of many “One Call System Directory” services. If you do not know the local number, call the national number (U.S.A. and Canada only): 1-888-258-0808.

IMPORTANT: *Check with local authorities for laws, regulations and/or strict penalties requiring you to locate and avoid existing utilities.*



WARNING: *Contact with high voltage power lines, underground cables, etc., can cause serious injury or death from electrocution. Keep machine and attachments a safe distance from electrical power lines. Failure to comply could result in injury or death.*

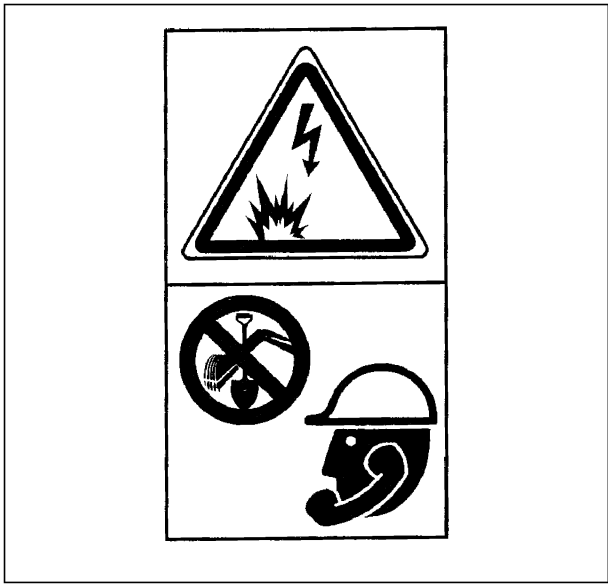

RH99G001 Figure 2

CALL ALL LOCAL UTILITY COMPANIES BEFORE YOU PERFORM ANY MACHINE OPERATION

- Know the utility color code (U.S.A. and Canada):
- Electric Red
 - Gas, Oil, or Petroleum. Yellow
 - Communication, Telephone, Television. . . Orange
 - Water Blue
 - Sewer Green/Brown
 - Proposed Excavation White
 - Surveying Pink
 - Reclaimed Water and Slurry. Purple

After locating any buried utility lines, carefully dig a hole by hand and/or automatic vacuum equipment to the utility line to verify the location and depth of the line.

PERSONAL

- Be prepared for emergencies. Always have a first aid kit and a working fire extinguisher with you and know how to use each.
- Avoid loose fitting clothing, loose or uncovered long hair, jewelry and loose personal articles.
- Know and use the protective equipment that is to be worn when operating this machine. Hard hats, protective glasses, protective shoes, gloves, reflector type vests, respirators and ear protection are examples of equipment that may be required.
- Certain protective equipment should be replaced and renewed upon age and wear. Old hard hats may not afford the original intended protection. Faded and soiled vests are no longer as highly visible as the original intent. See the manufacturer's recommendation.
- Do not rush. Walk, do not run.
- Know and use the hand signals required for particular jobs and know who has the responsibility for signaling.

GENERAL

- It is the responsibility of the operator to read and understand the Operator's Manual and other information provided, and use the correct operating procedure. Machines should be operated only by qualified operators.
- Do not operate this machine or perform maintenance work if you have not had appropriate training. Read and fully understand all the instructions and warnings in this manual.
- Wear the seat belt to maximize the protection capability of a ROPS (Roll Over Protective Structure) when the machine is so equipped.
- Inspect the ROPS and seat belt mounting bolts on a daily basis to insure their integrity.
- Do not permit riders on the machine if there is no manufacturer's designated place for a rider.
- Make sure that all protective guards, canopies, doors, etc. are in place and secure.
- Remove all loose objects stored in the machine. Remove all objects which do not belong in or on the machine and its equipment.

MOUNTING AND DISMOUNTING PRECAUTIONS



BD06F163

Figure 3

- Use the recommended hand holds and steps with at least three points of support when getting on and off the machine. The door must be latched and secured in the open position before using the door hand hold. Keep steps and platform clean. Face the machine and use the hand holds and steps adhering to a three-point access system when climbing up and down.
- Do not jump off the machine.
- Do not dismount while the machine is in motion.
- Foreign material or grease on the steps and hand holds can cause an accident. Keep the steps and hand holds clean.

STARTING AND STOPPING PRECAUTIONS

- Walk around the machine and warn all personnel who may be servicing the machine or are in the machine path prior to starting. Do not start until all personnel are clearly away from the machine. Sound the horn, if equipped, before starting.
- Walk around the machine's tool, attachment, or furthest contact point to view operation danger area from the work site personnel's view and angle.
- Check that the parking device is applied, place the transmission in neutral or park as specified by the manufacturer, and disengage the PTO, if so equipped, before starting the machine.
- Adjust, secure and latch the seat and fasten the seat belt before starting the machine.
- Start and operate the machine only from the operator's station.
- Do not bypass the machine's neutral-start system. The neutral-start system must be repaired if it malfunctions.

- Use battery booster cables only in the recommended manner. Improper use can result in battery explosion or unexpected machine motion. Ventilate the battery area before using booster cables. Make sure that using booster cables will not interfere or harm electronic processing or computer devices.
- Do not operate the engine in an enclosed area without adequate ventilation.
- Park the machine on level ground whenever possible and apply the parking brake. On grades, park the machine with the wheels or track securely blocked.
- Before leaving the operator's station, lower the bucket/attachment to the ground, shut off the engine.
- Remove the starter key and/or use the disconnect switch when leaving the machine parked or unattended.
- Know and understand the job site traffic flow patterns and obey signalmen, road signs, and flagmen.
- Know and understand that job site conditions may change on an hourly basis. Hills of dirt, debris or obstructions may grow and change from the time you began the day. It is your responsibility to monitor the changes and keep the machine, tools and attachments, etc. a safe distance.
- Watch for bystanders and never allow anyone to be under or to reach through the machine and its equipment while operating.
- Select a gear that will prevent excessive speed when going downhill. Do not coast downhill.
- When roading a machine, know and use the signaling devices required on the machine. Provide an escort for roading where required.
- On machines with independently operated wheel brakes, lock the brake pedals together when roading to provide equalized brake application.

OPERATING PRECAUTIONS

- Check brakes, steering and other machine control devices in accordance with the manufacturer's instructions prior to starting operation. Observe all gauges or warning instruments for proper operation. Operate all controls to insure proper operation. If any malfunctions are found, remove the starter key or disconnect switch key. Place a DO NOT OPERATE tag on the machine until the malfunction is corrected.
- If a failure that causes loss of control such as steering, service brakes, or engine occurs, stop the machine motion as quickly as possible, remove the starter key or disconnect switch key. Place a DO NOT OPERATE tag on the machine, and keep it securely parked until the malfunction is corrected or the machine can be safely towed.
- Understand the machine limitations, and keep the machine under control.
- Operate and drive the machine with care and at speed compatible with conditions. Use extra caution when operating over rough ground, on slopes, and when turning.
- Note and avoid all hazards and obstructions such as ditches, underground lines, trees, cliffs, overhead electrical wires, or areas where there is danger of a slide.
- Carry loads in recommended positions for maximum stability.
- Never lift loads in excess of capacity.
- Use the recommended machine ballast and counterweighting.
- Use the recommended transport devices when roading the machine. Proper lights, flashers, signals, and beacons may be required. Use reflective slow moving vehicle signs where necessary. Follow local, state, and federal regulations.
- Use the approved drawbar and/or attachment point when using the machine for towing. If a cable or chain is used, keep people away from the tow line.
- Before you operate at night, check that all lamps illuminate.
- If your machine has a cab, make sure that all windows are clean and that the windshield wipers and washers work correctly.
- Engine exhaust fumes can cause death. If you operate this machine in an enclosed area, make sure there is ventilation to replace the exhaust fumes with fresh air.
- Check all controls in a clear area and make sure the machine is operating correctly.
- Dust, fog, smoke, etc., can decrease your vision and cause an accident. Stop the machine or decrease the speed until you can see.
- Contact with high voltage power lines, underground cables, etc., can cause serious injury or death from electrocution.
- Before you drive or operate in an area with high voltage lines, cables, or a power station, tell the power or utility company what you are going to do. You **MUST HAVE THE POWER DISCONNECTED OR KEEP A SAFE WORKING DISTANCE** from the lines, cables, or power station.

- Keep all parts of the machine a safe distance away from the power source. See the decal on the machine. You must also know any federal, state/provincial, or local safety codes or regulations that apply to the job site.

If a part of the machine touches high voltage power:

1. Warn other workers NOT TO TOUCH THE MACHINE and to stay away from the machine.
 2. If you can break contact, reverse the operation that caused contact with the high voltage power, and move the machine away from the danger area. If you cannot break contact stay in the machine until the utility company de-energizes the line and tells you that the power is off.
- If you have extreme conditions, such as a fire, etc., and you are forced to leave the machine, do not step off the machine. Jump as far from the machine as possible with your feet together and do not touch the ground with your hands.
 - Do not operate the machine if you do not feel well. This can be dangerous for you and for the people around you.
 - You must make a judgment if weather, road, or earth conditions will permit safe operation on a hill, ramp, or rough ground.
 - Stay away from hazardous areas such as ditches, overhangs, etc. Walk around the work area before you start and look for hazards.
 - Be alert and always know the location of all workers in your area. Keep all other persons completely away from your machine. Injury or death can result if you do not follow these instructions.
 - Develop fluid and smooth operating techniques, and maintain the surface condition where the machine travels in order to control vibration transfer to the operator.

MAINTENANCE PRECAUTIONS

- Do not attempt repairs unless trained. Refer to manuals and experienced repair personnel for help.
- Before you service the machine, put a DO NOT OPERATE tag on the key switch. Make sure that the machine is clearly "tagged out".
- Wear protective glasses and other required safety equipment when servicing or repairing the machine.
- Wear gloves to protect hands when handling cable.
- Disconnect the battery before working on the electrical system. Know the consequences of disconnecting any electronic or computer devices.

- Avoid lubrication or mechanical adjustments with the machine in motion or the engine operating. If the engine must be in operation to make certain adjustments, place the transmission in neutral, apply the parking device, place the bucket/attachment in a safe position, securely block the wheels and use extreme caution.
- Securely block the machine or any component that may fall before working on the machine or component. If possible, use a back up or secondary blocking device as well.
- To prevent unexpected movement, securely block working elements when repairing or changing working tool parts such as cutting edges.
- Never make repairs on pressurized components, fluid, gas or mechanical until the pressure has been relieved according to the manufacturer's instructions.
- Use extreme caution when removing radiator, reservoir, or tank caps, drain plugs, grease fittings or pressure taps. Park the machine and let it cool before opening a pressurized tank.
- Release all pressure before working on systems which have an accumulator.
- Use a piece of cardboard, newspaper, or wood to check for any pressurized leaks to prevent fluid penetrating the skin. Pressurize accumulators with the proper gas according to manufacturer's recommendations.
- When inflating tires, use a self-attaching inflation chuck with remote shutoff and stand clear of the tire. Position yourself beside the tire and not beside the rim.
- Towing this machine is not recommended.
- When absolutely necessary to tow the machine, do not exceed the recommended towing speed. Be sure the towing machine has sufficient braking capacity to stop the towed load. If the towed machine cannot be braked, a towbar must be used or two towing machines must be used - one in front pulling and one in the rear to act as a brake. Avoid towing over long distances.
- Observe proper maintenance procedures.
- Whenever servicing or replacing hardened pins, etc., use a brass drift or other suitable material between the hammer and pin. Alt: Use a brass hammer, drift or suitable material on the pin, etc.
- Keep the brakes and steering systems in good operating condition.
- Replace all missing, illegible or damaged safety signs or decals as necessary. Keep all safety signs and decals clean and legible.

FUEL HANDLING PRECAUTIONS

- Do not smoke or permit open flames while fueling or near fueling operations.
- Never remove the fuel cap or refuel gasoline or diesel engine powered machines with the engine running or hot. Never allow fuel to spill on hot machine components. Never allow spilled fuel to contaminate the environment.
- To avoid spilling fuel, maintain control of the fuel filler nozzle when filling the tank.
- Do not fill the fuel tank completely to the top. Allow room for expansion.
- Clean up spilled fuel immediately and dispose of contaminated material in an environmentally correct manner.
- Tighten the fuel tank cap securely. Should the fuel cap be lost, replace it only with the original manufacturer's approved cap. Use of a non-approved cap without proper venting may result in pressurization of the tank.
- Never use fuel for cleaning purposes.
- Use the correct diesel fuel grade for the operating season.

BURN PREVENTION

WARNING: BATTERY ACID CAUSES SEVERE BURNS. Batteries contain sulfuric acid. Avoid contact with skin, eyes or clothing.

Antidote: **EXTERNAL** - Flush with water.

Antidote: **INTERNAL** - Drink large quantities of water or milk.

DO NOT induce vomiting. Seek medical attention immediately.



EYES - Flush with water for 15 minutes and seek medical attention immediately.

WARNING: BATTERIES PRODUCE EXPLOSIVE GASES. Keep sparks, flame, cigars and cigarettes away. Ventilate when charging or using in enclosed area. Always wear eye protection when working near batteries. Wash hands after handling. **KEEP OUT OF REACH OF CHILDREN.** Failure to comply could result in serious injury or death.

M144B

- When the battery electrolyte is frozen, the battery can explode if, you try to charge the battery, or if you try to boost start and run the engine. To prevent the battery electrolyte from freezing, try to keep the battery at full charge. If you do not follow these instructions, you or others in the area can be injured.

- Hot coolant can spray out if the cooling system cap is removed. To remove the cap, let the cooling system cool, turn to the first notch, wait until the pressure is released, then remove the cooling system tank cap.

HAZARDOUS CHEMICAL PRECAUTIONS

- If you are exposed to or come in contact with hazardous chemicals you can be seriously injured. The fluids, lubricants, paints, adhesives, coolants, etc., used with your machine can be hazardous.
- Material Safety Data Sheets (MSDS) provide information about the chemical substances within a product, safe handling procedures, first aid measures and procedures to be taken when the product is accidentally spilled or released. This information is available from your dealer.
- Before you service your machine, check the MSDS for each fluid, lubricant, etc., used in this machine. This information indicates what the risks are and how to service the machine safely. Follow this information when servicing the machine.
- Before you service this machine and before you dispose of the old fluids and lubricants, always remember the environment. **DO NOT** put oil or fluids into the ground or into containers that can leak.
- Check with your local environmental or recycling center or your dealer for correct disposal information.

TRANSPORTING PRECAUTIONS

Know the rules, laws, and safety equipment necessary for transporting this machine on a road or highway.

FIRE EXTINGUISHER

It is recommended that you have a fire extinguisher on your machine. Contact your dealer for the type and location of a fire extinguisher on this machine.

SEAT BELT PRECAUTIONS

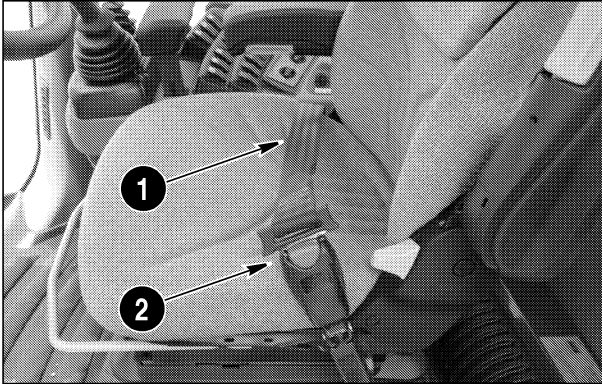

BD06G176

Figure 4

1. RIGHT-HAND BELT STRAP
2. LATCH MECHANISM

1. Insert the metal end of the right-hand belt strap into the latch mechanism on the left-hand side of the seat.
2. Tighten the seat belt by pulling on the loose end of the right-hand seat belt.



BD06G176

Figure 5

1. To unlatch the seat belt, press the red button on the left-hand side latch mechanism.

WARNING: Before starting the engine insure seat belts are securely fastened. The seat belt can help insure your safety if it is used and properly maintained. Never wear a seat belt loosely or with slack in the belt system. Never wear the belt in a twisted condition or pinched between the seat structural members. Failure to comply could result in serious injury or death.

M422A

WARNING: Securely fasten your seat belt. Your machine is equipped with a ROPS cab, ROPS canopy or ROPS frame for your protection. The seat belt can help insure your safety if it is used and maintained. Never wear a seat belt loosely or with slack in the belt system. Never wear the belt in a twisted condition or pinched between the seat structural members. Failure to comply could result in serious injury or death.

M437

SPECIFIC PRECAUTIONS TO THIS MACHINE

- Keep the load or bucket/attachment as low as possible while moving the machine around the jobsite.
- Never smoke while refueling.

LOADER LIFT ARM SUPPORT

WARNING: *If you service the machine with the loader lift arms raised, always use the support strut.*



1. Empty the loader bucket, raise the loader lift arms to approximately 7 ft. (2.1m) and stop the engine.
2. Remove the support strut from the storage position by removing the retaining bolt.
3. Place the support strut onto the cylinder rod with guide lock tab on top of cylinder and pointing toward the bucket.
4. Install the retaining bolt entirely into the support strut using all threads.
5. Slowly lower the lift arms onto the support strut.

If you do not follow this procedure, you can cause death or serious injury if the loader lift arms are lowered unexpectedly.

M824

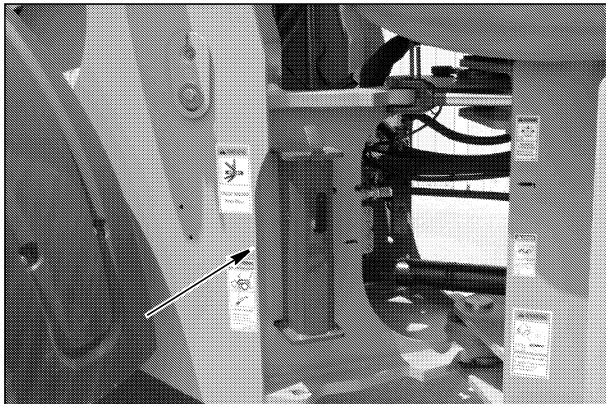

BD06G178

Figure 6

SUPPORT STRUT IN OPERATING POSITION

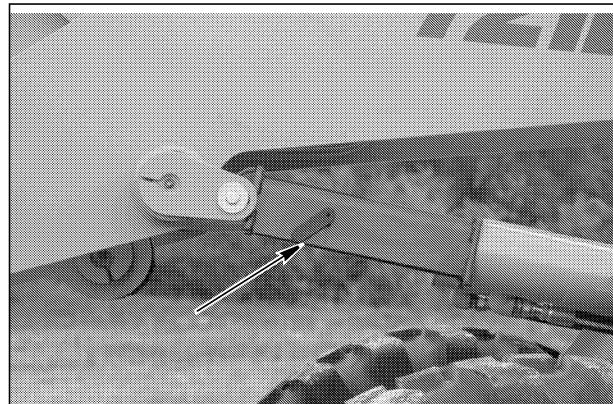

BD07A009

Figure 7

SUPPORT STRUT IN SERVICE POSITION

TRANSPORT SERVICE LINK

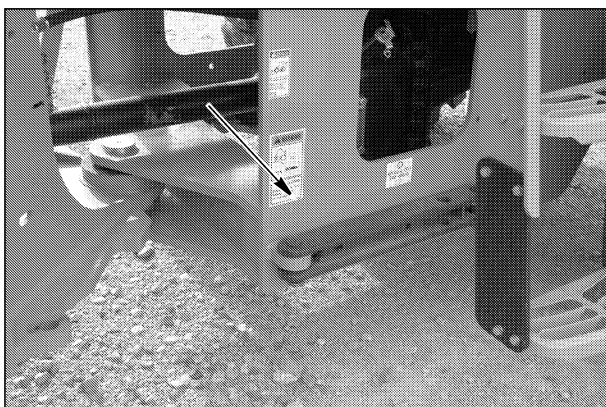

BD06G098

Figure 8

SERVICE LINK IN OPERATING POSITION

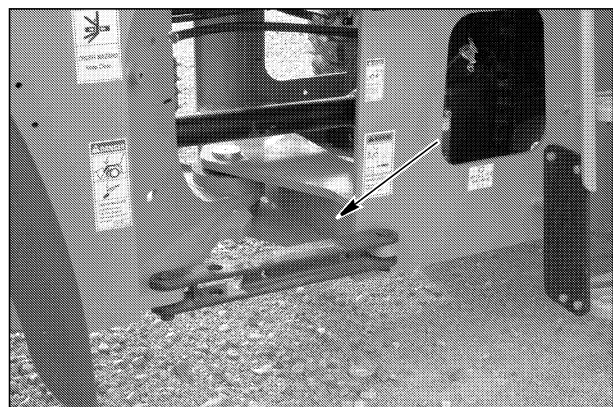

BD06G099

Figure 9

SERVICE LINK IN LOCKED POSITION

Prior to any maintenance, service work or transportation, lock the articulation transport service link. Remove the safety security pin to change positions of the service link.

DECALS



WARNING: An illegible or missing decal can have far-reaching consequences. Inspect decals daily. Clean and replace damaged decals as necessary. Failure to comply can result in machine damage, injury, or death.

CE-NA000



WARNING: Make sure that the decals are perfectly legible, clean them regularly and replace decals that are destroyed, lost, painted over or no longer legible with new ones. When parts bearing decals are replaced, be sure to put new decals on each new part. Failure to comply can result in machine damage, injury, or death.

CE-NA000

NOTE: When you clean the decals, use only a cloth, water and soap. Do not use solvents, gasoline, etc.

NOTE: This chapter only covers decals relating to safety and machine operation and servicing. For information on all decals for the machine, consult your authorized dealer.

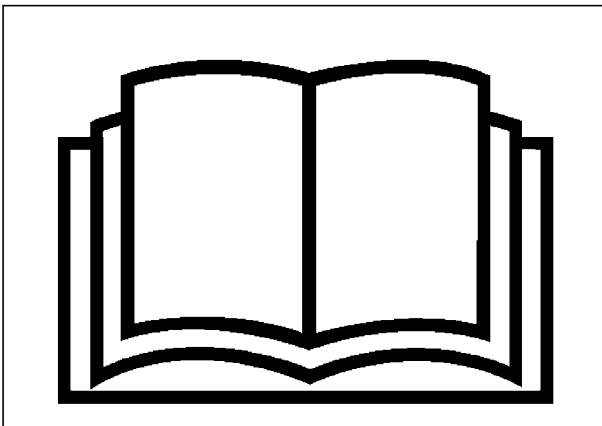

384270A1A

Figure 10

This symbol instructs you to refer the Operator's Manual.

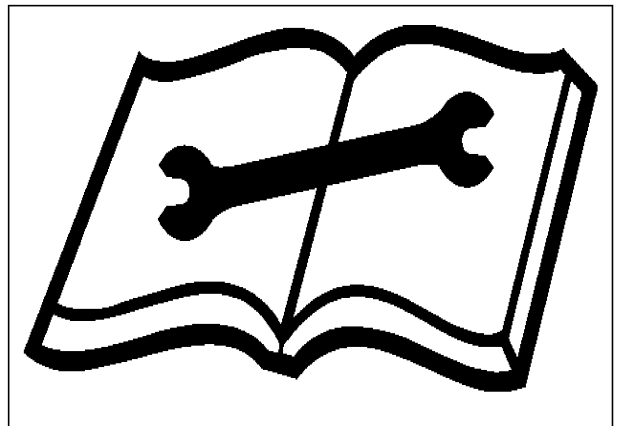

BC00G075

Figure 11

This symbol instructs you to refer to the Repair Manual.

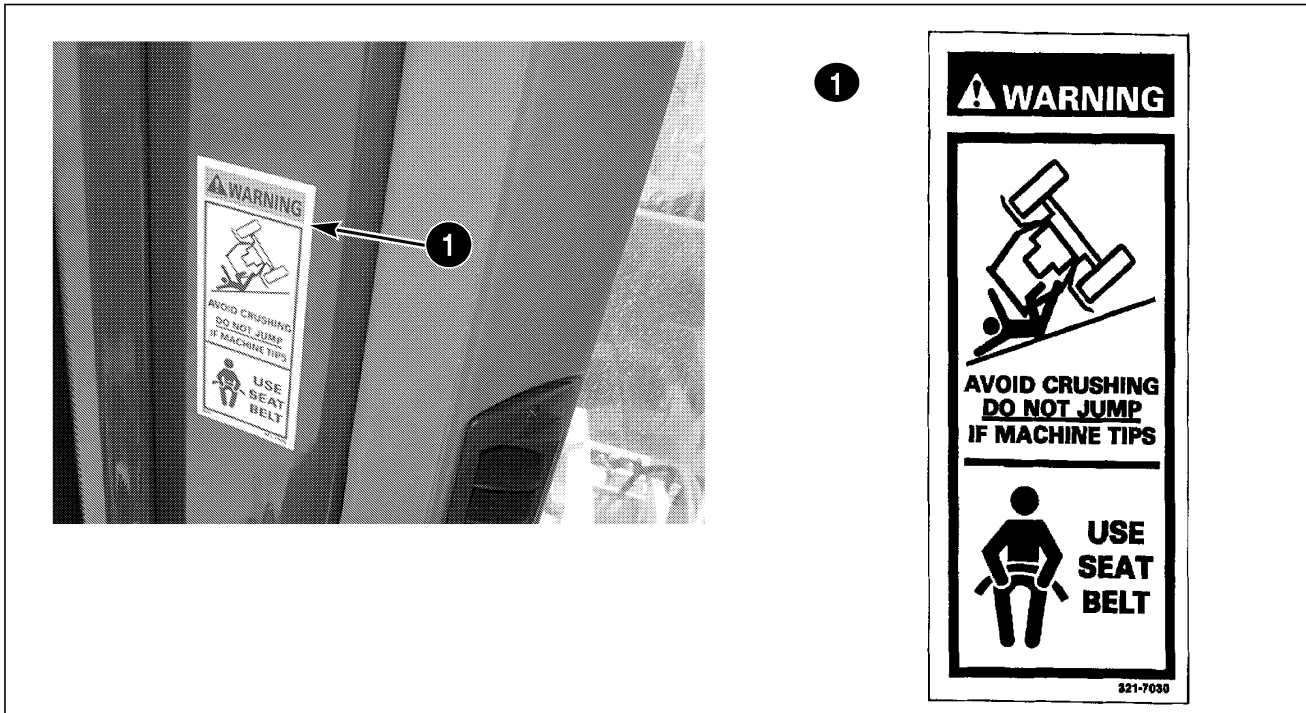

BD07G079/3217030

Figure 12



BD07G080/36474SA1/382622A1/329051A1

Figure 13

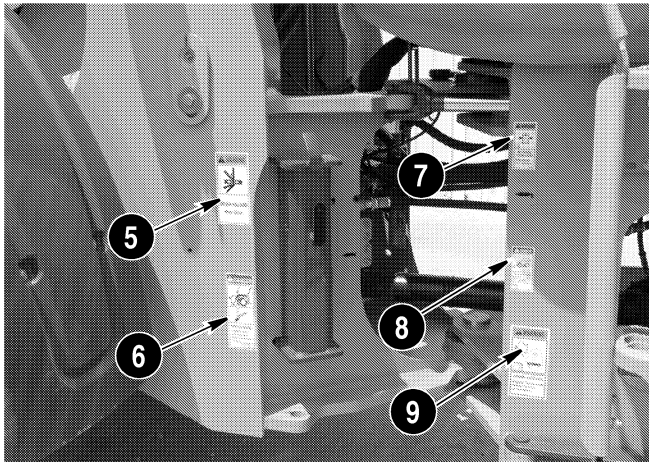

5

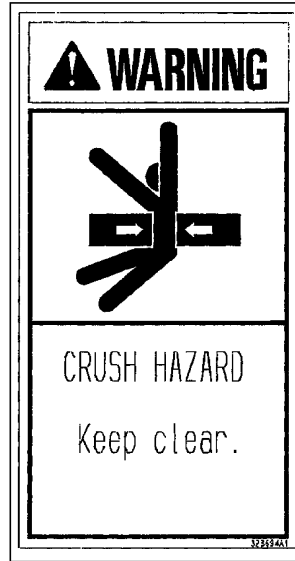

6



7

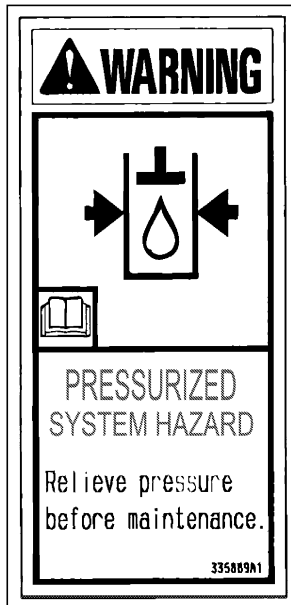

8

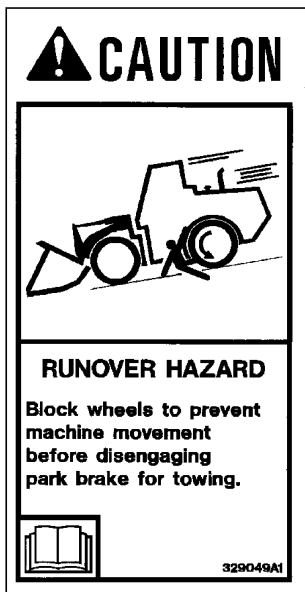

9

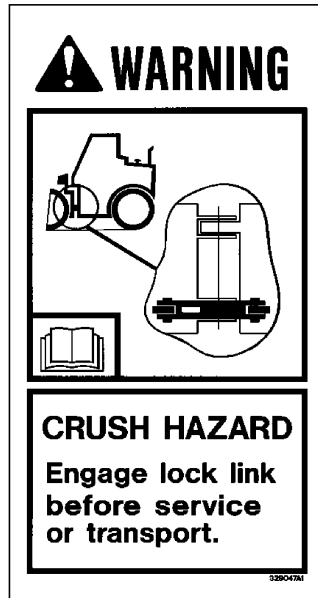

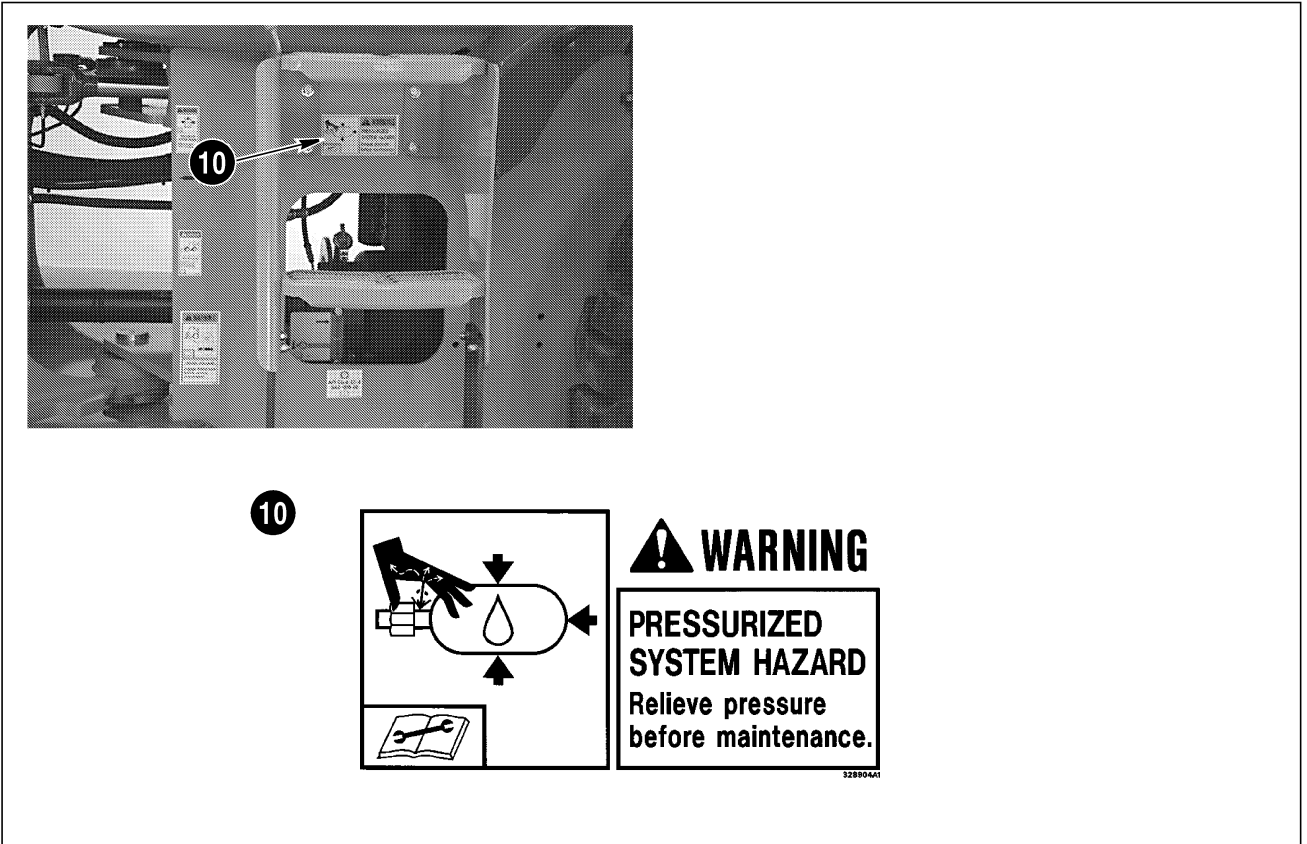

BD06F0327/328904A1

Figure 15

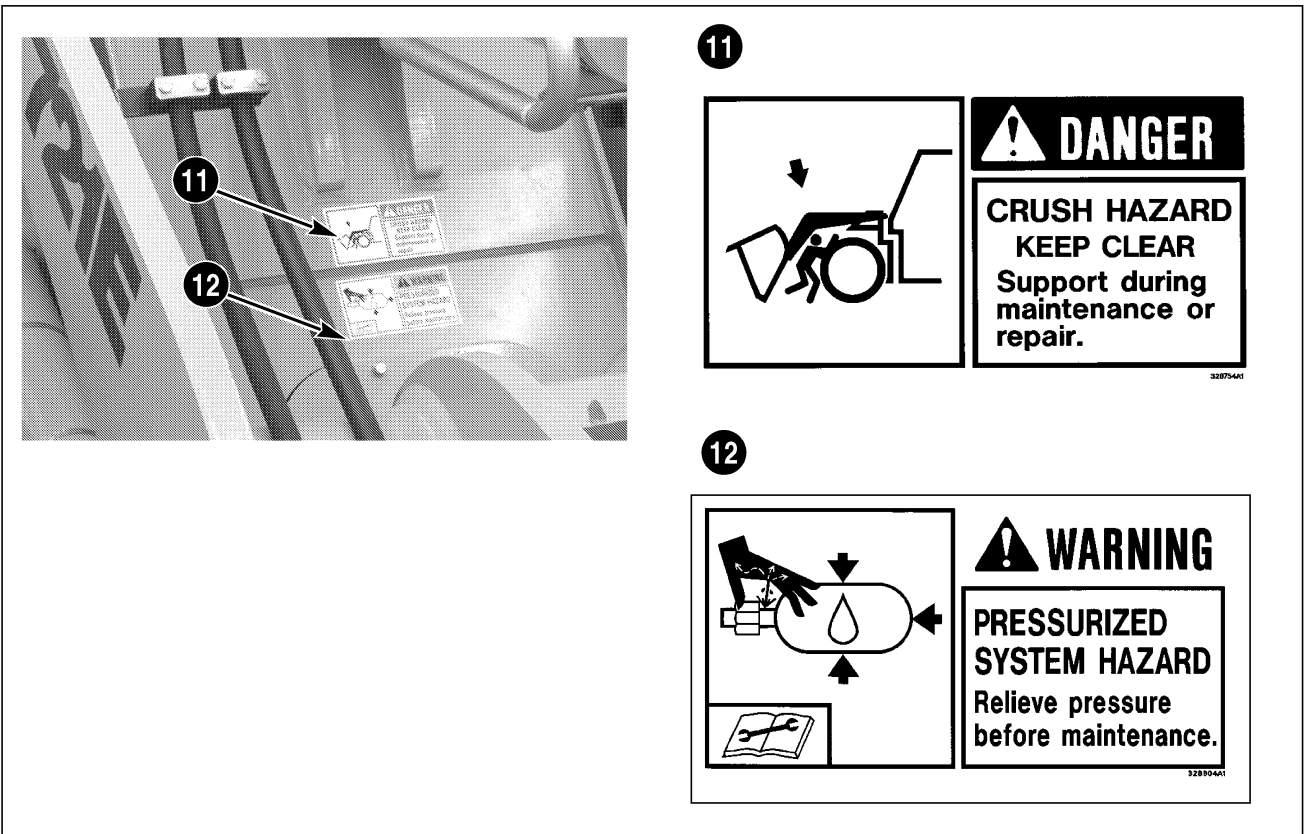

BD06F149-1 /328754A1/328904A1

Figure 16

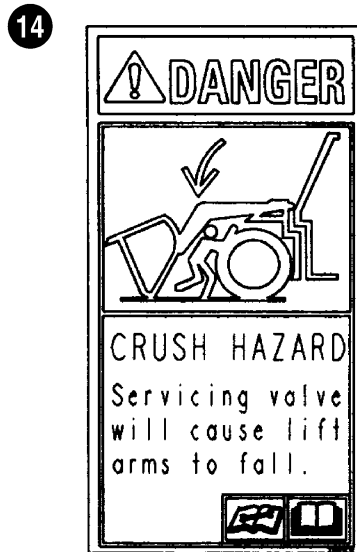
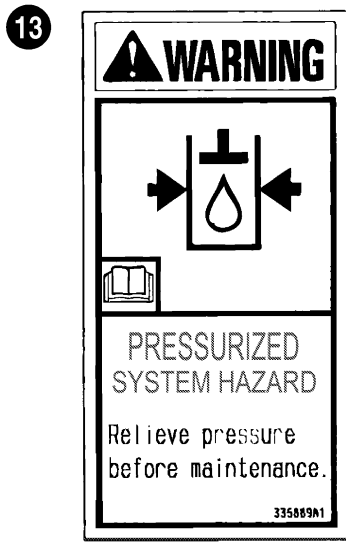
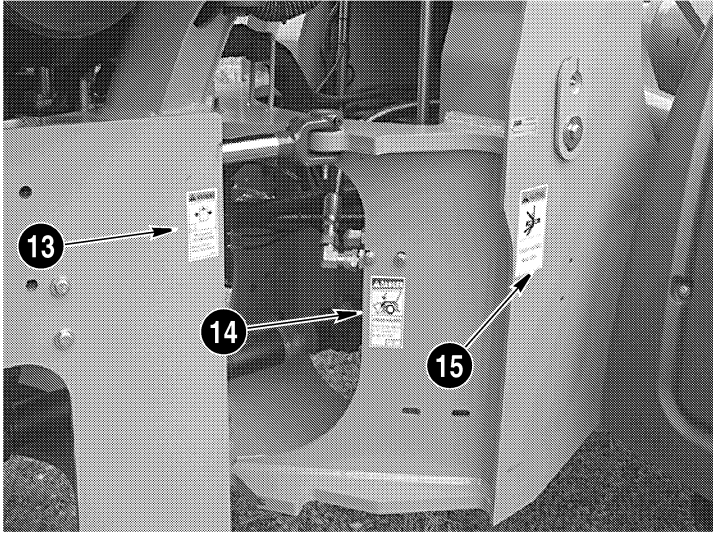

BD06G235/335889A1/87453132/323694A1

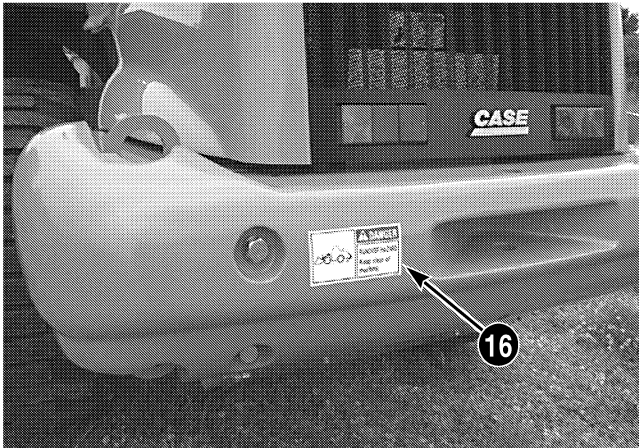

16

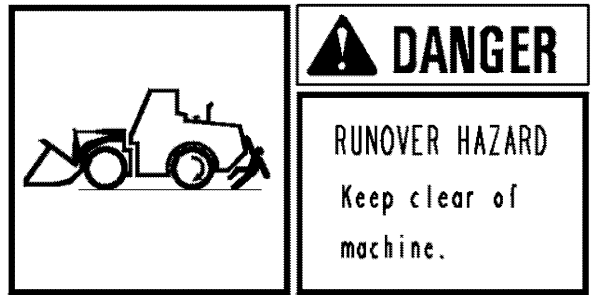

BD06G234/328752A1

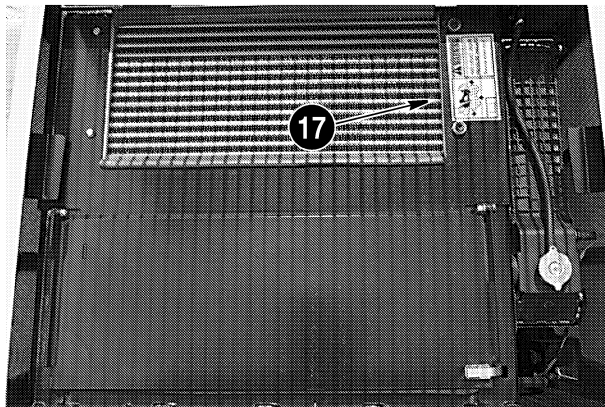

17



BD06F001/329044A1

Figure 17

This as a preview PDF file from best-manuals.com



Download full PDF manual at best-manuals.com