

OPERATION & MAINTENANCE



Paver Finisher Dynapac SD2550C / SD2550CS Typ 894 / 895

01-0516 4812313708

CN

Keep for later use in document compartment

Valid for:

_____ - _____
_____ - _____

Table of contents

V	Preface	1
1	General safety instructions	2
1.1	Laws, guidelines, accident prevention regulations	2
1.2	Warnings	2
1.3	Prohibitive symbols	4
1.4	Protective equipment	5
1.5	Environmental protection	6
1.6	Fire prevention	6
1.7	Additional information	7
2	CE identification and Declaration of Conformity	8
3	Guarantee conditions	8
4	Residual risks	9
5	Sensibly predictable incorrect usage	10
A	Correct use and application	1
B	Vehicle description	1
1	Application	1
2	Description of assemblies and functions	2
2.1	Vehicle	3
	Construction	3
3	Danger zones	7
4	Safety devices	8
5	Technical data, standard configuration	10
5.1	Dimensions (all dimensions in mm)	10
5.2	Allowed angle of rise and slope	11
5.3	Permissible approach angle	11
5.4	Weights SD2550C (all weights in t)	12
5.5	Weights SD2550CS (all weights in t)	12
5.6	Performance data SD2550C	13
5.7	Performance data SD2550CS	14
5.8	Travel drive/traction unit	15
5.9	Engine SD2550C	15
5.10	Engine SD2550CS	15
5.11	Hydraulic system	15
5.12	Material compartment (hopper)	16
5.13	Material transfer	16
5.14	Material distribution SD2550C	16
5.15	Material distribution SD2550CS	16
5.16	Screed lifting device	17
5.17	Electrical system	17
5.18	Permissible temperature ranges	17

6	Location of instruction labels and identification plates	18
6.1	Warning signs	20
6.2	Information signs	23
6.3	Instructive symbols, prohibitive symbols, warning symbols	26
6.4	Danger symbols	27
6.5	Further warnings and operating instructions	28
6.6	Identification label for the paver finisher (41)	30
7	EN standards	32
7.1	Continuous sound pressure SD2550C, Cummins QSB 6.7-C260	32
7.2	Operating conditions during measurement	32
7.3	Measuring point configuration.....	32
7.4	Continuous sound pressure SD2550CS, Cummins QSB 6.7-C260	33
7.5	Operating conditions during measurement	33
7.6	Measuring point configuration.....	33
7.7	Vibration acting on the entire body	34
7.8	Vibrations acting on handsand arms	34
C11	Transportation	1
1	Safety regulations for transportation	1
2	Transportation on low-bed trailers	2
2.1	Preparations	2
3	Securing the load	4
3.1	Prepare the low-bed trailer	4
3.2	Driving onto the low-bed trailer	5
3.3	Lashing equipment	6
3.4	Loading	7
3.5	Preparing the machine	8
4	Securing the load	9
4.1	Securing at the sides	9
4.2	Securing at the front.....	9
4.3	Securing at the rear - screed with side board	10
4.4	Securing at the rear - screed without side board	11
	Step 1: fasten lashing straps	11
	Step 2: fasten lashing chains	11
5	Control panel transport safeguard:	12
5.1	After transportation	13
6	Protective roof (o)	14
7	Transportation	15
7.1	Preparations	15
7.2	Driving mode	17
8	Loading by crane	18
9	Towing	20
10	Safely parking the vehicle	22

D11	Operation	1
1	Safety regulations	1
2	Controls	2
2.1	Operating panel	2
2.2	Special functions	50
	Reversible conveyor	50
3	Remote control	53
D20	Operation	1
1	Operation of the input and display terminal	1
	Button layout on the display	1
	Command symbols	2
	Menu range	2
1.1	Menu operation	3
	Menu structure of the setting and display options	5
	Main menu	6
	Displays:	6
	Menu 01 -	
	diesel engine speed	8
	Set-up menu 101 -	
	diesel engine speed	8
	Menu 02 -	
	drive engine measured values	9
	Sub-menu 201 -	
	drive engine measured value display	9
	Menu 03 -	
	paving distance	10
	Sub-menu 301 -	
	displaying, resetting paving distance /	
	automatic steering unit ON/OFF, steering monitoring	10
	Menu 04 -	
	external levelling	11
	Setting menu 401 -	
	external levelling	11
	Menu 05 -	
	paving thickness	12
	Set-up menu 501 -	
	paving thickness	
	preselection	12
	Menu 06 -	
	screed parameters	13
	Setting menu 600 -	
	compacting element frequencies	14
	Setting menu 601 -	
	delayed screed start	14
	Setting menu 602 -	
	screed type selection	15
	Setting menu 603 -	
	screed heater system	15
	Menu 07 -	
	conveyor / auger capacity	16

	Set-up menu 700 - conveyor / auger capacity	16
	Menu 08 - system information	17
	Menu 09 - service	18
	Menu 10 - error memory	19
	Query menu 111 - error memory:	19
	Error display	20
	Menu 11 - terminal settings	21
	Setting menu 110 - terminal settings	21
	System menu - Basic settings Display	22
	Menu 12 - button function test	23
	Test menu 120 - button function test	23
	Menu 13 - camera display (camera 2)	24
	Menu 13b - camera display (camera 1)	24
2	Terminal error messages	25
2.1	Drive engine error codes	44
2.2	Error codes	46
D30	Operation	1
1	Operating elements on the paver finisher	1
1.1	Control elements on the operator's control station	1
	Protective roof (o)	1
	Protective cabin (o)	2
	Windscreen wiper	2
	Control panel, rigid	3
	Operating panel, moveable	3
	Control platform, moveable (o)	4
	Operating panel, moveable	5
	Operating panel, swivelling (o)	5
	Control platform lock (o)	5
	.Emergency actuation control platform, movable	6
	Seat console, swivelling (o)	7
	Seat console storage compartment	7
	Driver's seat, type I	8
	Driver's seat, type II	9
	Fuse box	10
	Batteries	11
	Main battery switch	11
	Hopper transport safeguard	12
	Screed lock, mechanical (o)	12

	Screed lock, hydraulic (o)	13
	Paving thickness indicator	14
	Auger lighting (o)	15
	Engine compartment lighting (o)	15
	Xenon working light (o)	16
	LED working light (o)	16
	500 watt spotlight (o)	17
	Camera (o)	17
	Auger height adjustmentatchet (o)	18
	Auger height indicators	18
	Sensor rod / sensor rod extension	19
	Manual separator fluid spray(o)	21
	Separator fluid spraying system(o)	22
	Conveyor limit switches -PLC version	23
	Conveyor limit switches -conventional version	24
	Ultrasonic auger limit switches (left and right) - PLC version	25
	Ultrasonic auger limit switches (left and right) - conventional version	26
	24 volt / 12 volt sockets (o)	27
	Pressure control valve for screed charging/relieving	28
	Pressure control valve for paving stop with relieving	28
	Manometer for screed charging/relieving	28
	Central lubrication system (o)	29
	Lane clearer (o)	30
	Screed eccentric adjustment	31
	Push roller crossbar, adjustable	32
	Push roller crossbar, hydraulically extendable (o)	33
	Push roller damping, hydraulic (o)	33
	Storage box	34
	Fire extinguisher (o)	34
	Rotary beacon (o)	35
	Fuelling pump (o)	36
	Power moon (o)	37
D41	Operation	1
1	Preparing for operation	1
	Required devices and aids	1
	Before starting work (in the morning or when starting paving)	2
	Check list for the vehicle operator	2
	4
1.1	Starting the paver finisher.....	5
	Before starting the paver finisher	5
	"Normal" starting	5
	External starting (starting aid)	7
	After starting	9
	Observe indicator lamps	11
	Engine coolant temperature check (79)	11
	Battery charge indicator (83)	11
	Oil pressure indicator lamp for the diesel engine (86)	11

	Oil pressure indicator lamp for the travel drive (87).....	13
1.2	Preparation for transportation	15
	Driving and stopping the paver finisher	17
1.3	Preparations for paving	18
	Separator fluid	18
	Screed heater system	18
	Direction marks	19
	Loading/conveying material	21
1.4	Starting for paving	23
1.5	Checks during paving	24
	Paver function	24
	Quality of the layer	24
1.6	Paving with "screed control at paving stop" and "screed charging/relieving"	25
	General	25
	Screed charging/relieving	27
	Screed control with paver finisher stop / in paving operation (screed stop / paving stop / floating paving)	27
	Adjusting the pressure	31
	Setting pressure for screed control with paving stop + relieving:.....	31
1.7	Interrupting/terminating operation	33
	During breaks (e.g. the material supply truck is late).....	33
	During longer breaks (e.g. lunch break)	33
	When work is finished	35
2	Malfunctions	36
2.1	Problems during paving	36
2.2	Malfunctions on the paver finisher or screed	38
E11	Set-up and modification	1
1	Special notes on safety	1
2	Distribution auger	2
2.1	Height adjustment	2
	Grain sizes up to 16 mm	2
	Grain sizes > 16 mm	2
2.2	Mechanical adjustment with ratchet (o)	3
2.3	Hydraulic adjustment (o)	3
2.4	Height adjustment for large working widths / with brace	4
3	Auger extension	6
3.1	Mounting extension parts	7
	Mounting the material shaft and auger extension	7
	Mounting the outer auger bearing	8
	Mounting the auger end bearing	9

3.2	Auger extension chart	10
	Auger upgrading, working width 3.14 m	12
	Auger upgrading, working width 3.78 m	12
	Auger upgrading, working width 4.42 m	12
	Auger upgrading, working width 5.06 m	13
	Auger upgrading, working width 5.70 m	13
	Auger upgrading, working width 6.34 m	14
	Auger upgrading, working width 6.98 m	15
	Auger upgrading, working width 7.62 m	16
	Auger upgrading, working width 8.26 m	17
	Auger upgrading, working width 8.90 m	18
	Auger upgrading, working width 9.54 m	19
	Auger upgrading, working width 10.18 m	20
	Auger upgrading, working width 10.82 m	21
	Auger upgrading, working width 11.46 m	22
	Auger upgrading, working width 12.10 m	23
	Auger upgrading, working width 12.74 m	24
3.3	Mounting the auger brace	25
3.4	Aligning the auger	27
3.5	Material shaft, hinged	29
3.6	Hopper scraper	30
4	Offsetting the screed	31
5	Levelling	32
5.1	Slope controller	32
5.2	Mounting the sensor arm	33
5.3	Mounting the grade control system	33
5.4	Setting up the sensor arm	34
5.5	Big ski 9 m, big ski 13 m	35
	Mounting the big ski bracket on the crossbeam	37
	Mounting the swivel arms	38
	Mounting the centre element	39
	Extending the big ski	40
	Mounting the sensor bracket	41
	Mounting and aligning the sensors	42
	Mounting the distributor box	43
	Connection diagram	44
6	Automatic steering unit	45
6.1	Mounting the automatic steering unit on the paver finisher	46
	Mounting and aligning the sensor	47
	Connecting the sensor	47
	Automatic steering unit operating instructions	48
7	Emergency stop during feeder operation	49
8	Limit switch	50
8.1	Auger limit switches (left and right) - mounting the PLC version	50
9	Screed	51
10	Electrical connections	51
10.1	Machine operation without remote control / side board	52

F10	Maintenance	1
1	Notes regarding safety	1
F22	Maintenance review ..	1
1	Maintenance review	1
F31	Maintenance - conveyor.....	1
1	Maintenance - conveyor	1
1.1	Maintenance intervals	2
1.2	Points of maintenance	3
	Chain tension, conveyor (1)	3
	Conveyor drive - drive chains (2)	5
	Conveyor deflectors / conveyor plates (3)	6
F40	Maintenance - auger assem bly	1
1	Maintenance - auger assembly	1
1.1	Maintenance intervals	2
1.2	Points of maintenance	4
	Outer auger bearing (1)	4
	Auger planetary gear (2)	5
	Drive chains of the augers (3)	6
	Auger box (4)	7
	Seals and sealing rings (5) ..	8
	Gearbox bolts Check tightening (6)	9
	Mounting screws - Outer auger bearing Check tightening (7)	9
	Auger blade (8)	10
F50	Maintenance - engine assembly	1
1	Maintenance - engine assembly	1
1.1	Maintenance intervals	2
1.2	Points of maintenance	5
	Engine fuel tank (1)	5
	Engine lube oil system (2)	6
	Engine fuel system (3)	8
	Engine air filter (4)	10
	Engine cooling system (5)	12
	Engine drive belt (6)	14

F60	Maintenance - hydraulic system	1
1	Maintenance - hydraulic system	1
1.1	Maintenance intervals	2
1.2	Points of maintenance	4
	Hydraulic oil tank (1)	4
	Suction/return flow hydraulic filter (2)	6
	Bleeding the filter	7
	High-pressure filter (3)	8
	Pump distribution gear (4)	9
	Bleeder	10
	Hydraulic hoses (5)	11
	Marking hydraulic hoses / storage period, period of use	13
	Auxiliary flow filter (6)	14
F71	Maintenance – drive units	1
1	Maintenance – drive units	1
1.1	Maintenance intervals	2
1.2	Points of maintenance	5
	Chain tension (1)	5
	Bottom plates (2)	8
	Rollers (3)	9
	Planetary gear (4)	10
	Screw connections	12
F81	Maintenance - electrical system	1
1	Maintenance - electrical system.....	1
1.1	Maintenance intervals	2
1.2	Points of maintenance	3
	Batteries (1)	3
	Alternator (2)	4
	Insulation faults	5
	Cleaning the generator	6
	Electrical fuses / relays (3)	7
	Fuses in terminal box (B) ..	8
	Relays in terminal box (C) ..	10
	Relays in the engine compartment (E)	12
F90	Maintenance - lubricating points	1
1	Maintenance - lubricating points.....	1
1.1	Maintenance intervals	2
1.2	Points of maintenance	3
	Central lubrication system (1)	3
	Bearing points (2)	7

F100	Tests, stopping	1
1	Tests, checks, cleaning, stop ping	1
1.1	Maintenance intervals	2
2	General visual inspection	3
3	Inspection by an expert	3
4	Cleaning	4
5	Preserving the paver finisher	5
5.1	Shutdowns for up to 6 months	5
5.2	Shutdowns lasting from 6 months to 1 year	5
5.3	Recommissioning the machine	5
6	Environmental protection, disposal	6
6.1	Environmental protection	6
6.2	Disposal	6
F110	Lubricants and operating substances	1
1	Lubricants and operating substances	1
1.1	Capacities	3
2	Lubricant specifications	4
2.1	Engine	4
2.2	Cooling system	4
2.3	Hydraulic system	4
2.4	Pump distribution gear	4
2.5	Drive unit planetary gear	5
2.6	Auger drive planetary gear	5
2.7	Auger box	5
2.8	Grease	5
2.9	Hydraulic oil	6

V Preface

Translation of the original operating instructions.

If the vehicle is to be operated safely, the information provided in these operating instructions will be required. The information is provided in a concise, clearly structured form. The individual chapters are arranged in alphabetical order, and every chapter starts with page 1. The individual pages are identified by the chapter letter and the page number.

Example: Page B 2 is the second page of chapter B.

These operating instructions cover various vehicle options. Make sure that during operation and maintenance work the description appropriate to the vehicle option is used.

In the interest of continued development, the manufacturer reserves the right to make changes to the vehicle (which will not, however, change the essential features of the type of vehicle described) without updating the present operating instructions at the same time.

Dynapac (China) Compaction & Paving Equipment Co., Ltd.
No.38, Quanwang Road,
Wuqing High Tech Industrial Park, 301700,
Tianjin, China
www.dynapac.com

1 General safety instructions

1.1 Laws, guidelines, accident prevention regulations

-  The locally applicable laws, guidelines and accident prevention regulations must always be observed, even if these are not expressly named here.
The user himself/herself is responsible for compliance with the resulting regulations and measures!

-  The following warnings, prohibitive symbols and instructive symbols indicate dangers for persons, the vehicle and the environment due to residual risks when operating the vehicle.

-  Failure to observe this information, prohibitions and instructions can result in life-threatening injuries!

-  The "Guidelines for the Correct Use and Application of Paver Finishers" compiled by Dynapac must also be observed!

1.2 Safety signs, signal words

In the safety instructions, the signal words "Danger", "Warning", "Caution", "Note" are positioned in the coloured title block. They follow a certain hierarchy; in combination with the warning symbol, they indicate the severity of the danger or the type of note.

"Danger"!



Danger of personal injury.

Indication of an immediately threatening danger that result in fatal or severe injuries unless the corresponding actions are taken.

"Warning" !



Indication of a possible danger that can result in fatal or severe injuries unless the corresponding actions are taken.

"Caution" !



Indication of a possible danger that result in moderate or minor injuries unless the corresponding actions are taken.

"Note" !



Indication of a possible drawback unless the corresponding actions are taken, e.g. unwanted conditions or consequences can occur.

1.3 Other supplementary information

Other information and important explanations are identified by the following pictograms:



Precedes safety instructions that must be observed in order to prevent danger to personnel.



Precedes notes that must be observed to prevent damage to equipment.



Precedes general notes and explanations.

1.4 Warnings

Warning on a dangerous area or hazard!

Failure to observe the warnings can result in life-threatening injuries!



Warning on danger of being pulled in!



In this working area/on this element there is a danger of being pulled in by rotating or conveying elements!
Only carry out activities with elements switched off!



Warning on dangerous electrical voltage!



All maintenance and repair work on the screed's electrical system must always be carried out by an electrician!



Warning on suspended loads!



Never stand under suspended loads!



Warning on danger of crushing!



There is a danger of crushing when certain components are operated, or certain functions or vehicle movements are carried out.
Always make sure that there are no persons within the endangered areas!



Warning on hand injuries!



Warning on hot surfaces or hot liquids!



Warning on danger of falling!



Warning on dangers posed by batteries!



Warning on hazardous or irritating substances!



Warning on substances which constitute a fire hazard!



Warning on gas bottles!



1.5 Prohibitive symbols

Opening/walking on/reaching in/carrying out/setting up are prohibited during operation or while the drive engine is running!

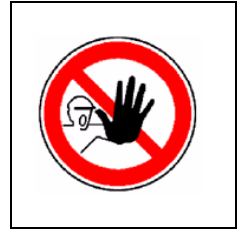

Do not start engine/drive!
Maintenance and repair work may only be carried out with the diesel engine shut down!



Spraying with water is prohibited!



Extinguishing with water is prohibited!



Unauthorised maintenance is prohibited!
Only qualified experts may conduct maintenance!

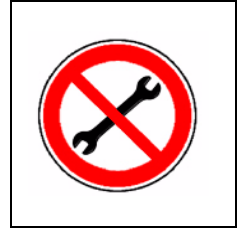

 Consult the Dynapac Service Department

Fire!, naked flames and smoking are prohibited!



Do not switch!



1.6 Protective equipment



Locally applicable regulations may require the wearing of various safety equipment!
Always observe these regulations!

Wear safety goggles to protect your eyes!



Wear suitable head protection!



Wear suitable hearing protection to protect your hearing!



Wear suitable safety gloves to protect your hands!



Wear safety shoes to protect your feet!



Always wear close-fitting work clothing!
Wear a warning vest to be seen in time to avoid accidents!



Wear respiratory equipment if breathing air is contaminated!



1.7 Environmental protection

 The locally applicable laws, guidelines and accident prevention regulations for the proper recycling and disposal of waste must always be observed, even if these are not expressly named here.

Water-endangering substances like:

- Lubricants (oil, grease)
- Hydraulic oil
- Diesel fuel
- Coolant
- Cleaning liquids

must not get into the soil or sewer system during cleaning, maintenance and repair work!

Substances must be caught, stored, transported and brought to professional disposal sites in suitable containers!

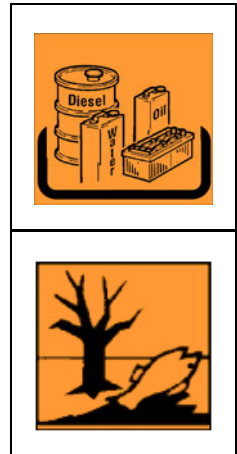

Environmentally hazardous substance!

1.8 Fire prevention

 Locally applicable regulations may require suitable extinguishing agents to be carried on the vehicle!

Always observe these regulations!

Fire extinguisher!
(optional equipment)



1.9 Additional information



Also observe the manufacturer's documentation and additional documentation!



For example, the maintenance instructions of the engine manufacturer



Description / depiction applicable when equipped with gas heater!



Description / depiction applicable when equipped with electric heater!

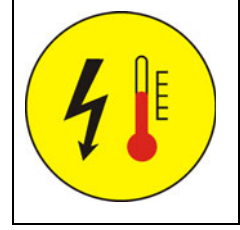
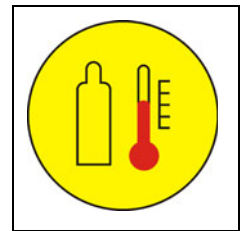
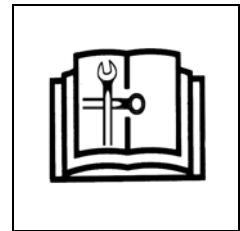

- Used to indicate standard equipment.
- Used to indicate optional equipment.

2 CE identification and Declaration of Conformity

(only applies to machines sold in the EU/EEC)

This machine has CE identification. This identification says that the machine fulfils the basic health and safety requirements pursuant to the Machinery Directive 2006/42/EC together with all other valid regulations. The scope of supply of the machine includes a Declaration of Conformity as specified in the valid regulations and amendments together with harmonised standards and other valid provisions.

3 Guarantee conditions



The guarantee conditions are included in the scope of supply of the machine. This contains a complete specification of the valid conditions.

The guarantee becomes null and void if

- damage occurs through malfunctions caused by improper use and incorrect operation.
- repairs or manipulations are carried out by persons who are neither trained nor authorised accordingly.
- accessories or spare parts are used that cause damage and which are not approved by Dynapac.

4 Residual risks

These are risks that remain even if all possible measures and safety precautions have been taken to help minimise dangers (risks) or to reduce their probability and scope to zero.

Residual risks in the form of

- **Danger to life and limb of persons at the machine**
- **Danger to the environment posed by the machine**
- **Damage to property and restricted output and functionality of the machine**
- **Damage to property in the operating range of the machine**

caused by:

- wrong or improper use of the machine
- defective or missing safety devices
- use of the machine by untrained, uninstructed staff
- defective or damaged parts
- incorrect transport of the machine
- incorrect maintenance or repairs
- leaking operating substances
- emission of noise and vibrations
- impermissible operating substances

Existing residual risks can be avoided by complying and implementing the following:

- warnings at the machine
- warnings and instructions in the safety manual for paver finishers and in the operating instructions of the paver finisher
- Operating instructions of the machine operator

5 Sensibly predictable incorrect usage

Every kind of sensibly predictable incorrect usage of the machine constitutes misuse. Incorrect usage makes the manufacturer's warranty null and void: the operator bears sole responsibility.

Sensibly predictable incorrect usage of the machine includes:

- presence in the danger zone of the machine
- transporting persons
- leaving the operator's platform while the machine is operating
- removing protection or safety devices
- starting and using the machine outside the operator's platform
- operating the machine with the screed walkway plate hinged up
- failing to comply with the maintenance instructions
- omission or incorrect execution of maintenance or repair work
- spraying the machine with high pressure cleaners

A Correct use and application



The "Guidelines for the Correct Use and Application of Paver Finishers" compiled by Dynapac are included in the scope of delivery for the present machine. The guidelines are part of the present operating instructions and must always be heeded. National regulations are fully applicable.

The road construction machine described in these operating instructions is a paver finisher that is suited for laying mixed materials, roll-down concrete or lean-mixed concrete, track-laying ballast and unbound mineral aggregates for foundations for paving.

The paver finisher must be used, operated and maintained according to the instructions given in the present operating instructions. Any other use is regarded as improper use and can cause injury to persons or damage to the paver finisher or other equipment or property.

Any use going beyond the range of applications described above is regarded as improper use and is expressly forbidden! Especially in those cases where the paver finisher is to be operated on inclines or where it is to be used for special purposes (construction of dumps, dams), it is absolutely necessary to contact the manufacturer.

Duties of the user: A "user" within the meaning of these operating instructions is defined as any natural or legal person who either uses the paver finisher himself, or on whose behalf it is used. In special cases (e.g. leasing or renting), the user is considered to be the person who, in accordance with existing contractual agreements between the owner and the user of the paver finisher, is charged with the observance of the operating duties.

The user must ensure that the paver finisher is only used in the stipulated manner and that all danger to life and limb of the operator, or third parties, is avoided. In addition to this, it must be ensured that the relevant accident prevention regulations and other safety-related provisions as well as the operating, servicing and maintenance guidelines are observed. The user must also ensure that all persons operating the paver finisher have read and understood the present operating instructions.

Mounting of attachments: The paver finisher must only be operated in conjunction with screeds that have been approved by the manufacturer. Mounting or installation of any attachments that will interfere with or supplement the functions of the paver finisher is permitted only after written approval by the manufacturer has been obtained. If necessary, the approval of local authorities must be obtained.

Any approval obtained from local authorities does not, however, make approval by the manufacturer unnecessary.

B Vehicle description

1 Application

The Dynapac SD2550C / SD2550CS paver finisher is a paver finisher with a caterpillar drive which is used for paving bituminous mixed material, roll-down or lean-mixed concrete, track-laying ballast and unbound mineral aggregates for foundations for paving.

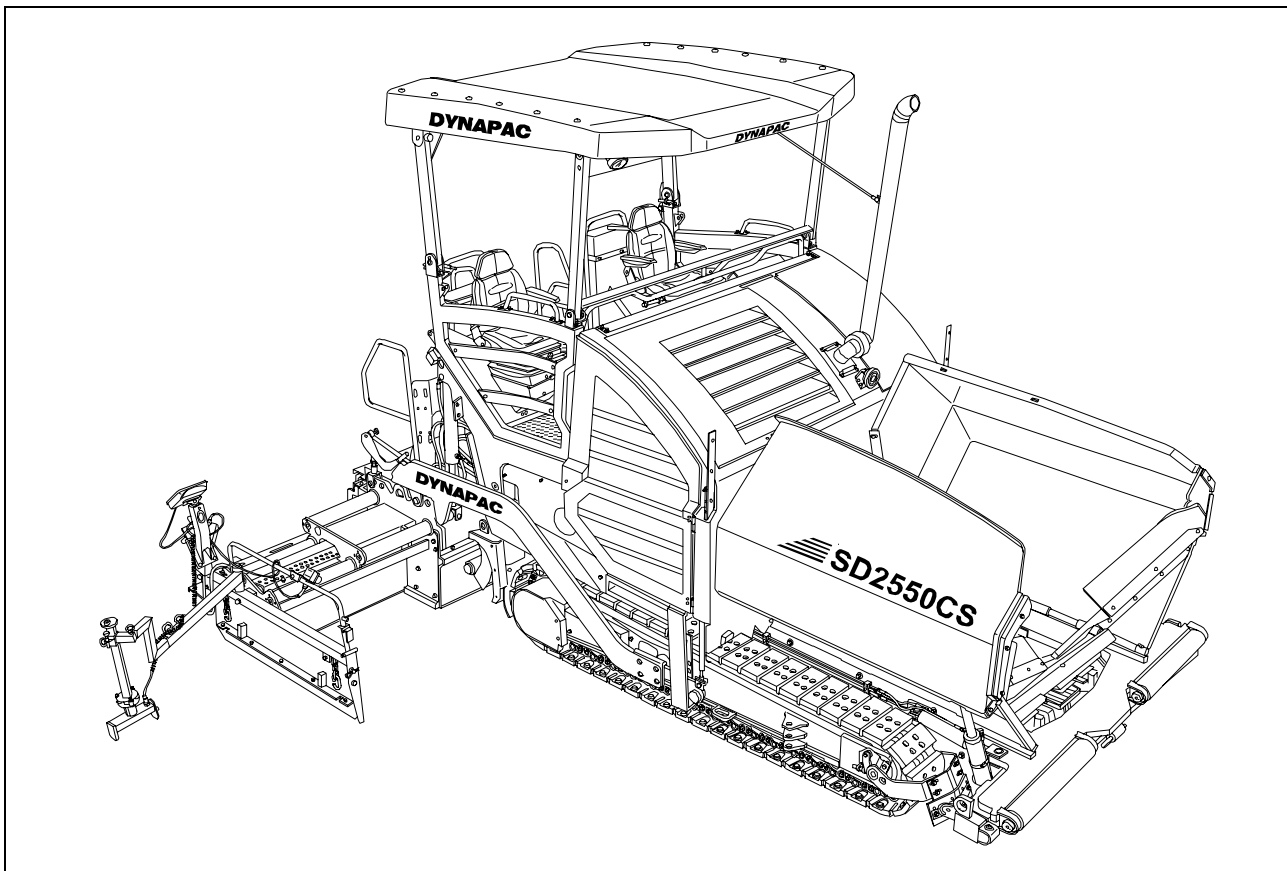

2 Description of assemblies and functions

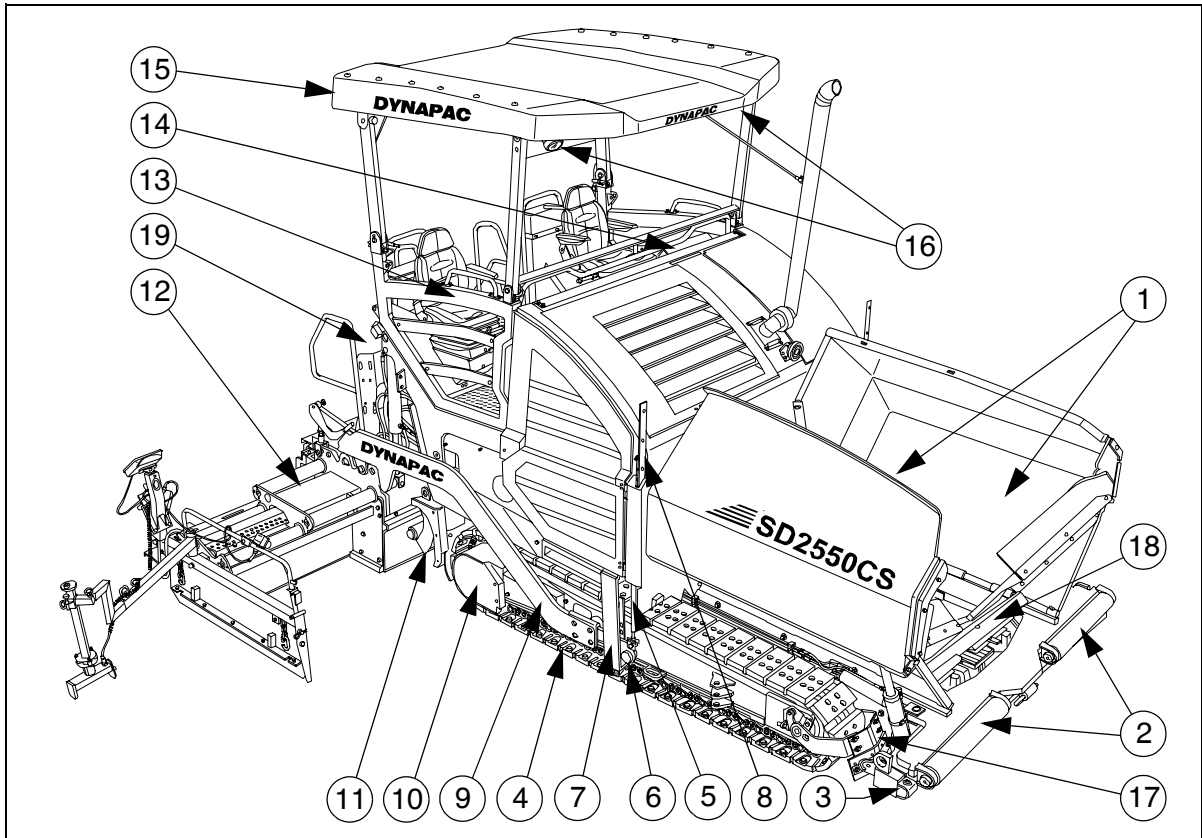

Item		Designation
1	●	Material compartment (hopper)
2	●	Push roller crossbar for truck docking
2	○	Push roller crossbar for truck docking, hydraulically extendable
3	●	Tube for sensor rod (direction indicator) and holder for levelling shoe
4	●	Caterpillar drive
5	●	Levelling cylinder for paving thickness
6	●	Traction roller
7	●	Crossbeam pull bar
8	●	Paving thickness indicator
9	●	Crossbeam
10	●	Travel drive of the caterpillar drive
11	●	Auger
12	●	Screed
13	●	Operator's platform (hydraulically movable)
14	●	Operating panel (can be moved to either side)
15	○	Protective roof
16	○	Working lights
17	●	Lane cleaner
18	○	Hydraulic front hopper flap
19	○	Asphalt fume control system

● = Standard equipment	○ = Optional equipment
------------------------	------------------------

2.1 Vehicle

Construction

The paver finisher has a welded steel frame on which the individual components are mounted.

The caterpillar drives compensate uneven areas on the ground; the suspension of the attached screed additionally helps to attain high paving precision.

The continuously adjustable hydrostatic travel drive allows the speed of the paver finisher to be matched to all work conditions.

The operation of the paver finisher is considerably facilitated by the automatic material handling system, the independent travel drives and the clearly structured operating components and controls.

The following extra equipment (option) is available:

- Automatic levelling/slope control system
- Ultrasonic sensors for material transfer (controller)
- Additional cut-off shoe
- Larger working widths
- Automatic central lubrication system for the finisher and/or the screed
- Protective roof / cab
- Additional headlights, warning lamps
- Emulsion spraying system
- Fuelling system
- Camera system
- Asphalt fume control system
- 12 volt system
- Further equipment and upgrade options on request

Engine: The paver finisher is driven by a water cooled diesel engine. For further details see the technical data and the engine's instruction manual.

Drive unit: Both caterpillar drives are directly driven by separate drives. They operate directly, without any drive chains which require maintenance or servicing. The tension of the caterpillar chains can be readjusted using tensioners. A swivelling lane cleaner (○), which ensures an even passage during paving, is located in front of each of the drive units. Small obstacles lying in the lane are cleared away to the side.

Hydraulic system: The diesel engine drives the hydraulic pumps for all main paver finisher drives via the attached distribution gear and its auxiliary drive shafts.

Travel drive: The continuously adjustable travel drive pumps are connected to the travel drive engines by means of high pressure hydraulic hoses. These hydraulic motors drive the caterpillar chains via planetary gears that are mounted directly inside the drive wheels of the caterpillar chains.

Steering system/operator's platform: The independent hydrostatic travel drives allow the paver finisher to be turned on the spot. Electronic synchronous control ensures precise straight-ahead travel. The operating panel can be hydraulically shifted beyond the left/right outer edge of the vehicle, providing the driver with a better view of the paving area in this position. The entire operating panel can be swivelled for operation beyond the outer edge of the vehicle, and can be additionally be locked in several positions along the control platform.

Push roller crossbar: The push rollers for material trucks are fastened to a cross bar that is pivoted at its centre. The paver finisher thus deviates less from its course and paving in curves is made easier. For adaptation to various truck design types, the push roller crossbar can be shifted to two positions.

The hydraulically extendable push roller crossbar (○) allows different distances to the rear wheels of material trucks to be infinitely compensated. The engageable push roller damping hydraulically absorbs the shocks between the material truck and paver finisher.

This as a preview PDF file from best-manuals.com



Download full PDF manual at best-manuals.com