

Shop Manual

HYDRAULIC
EXCAVATOR

PC228USLC-10

SERIAL NUMBERS 1002 and up

KOMATSU

SHOP MANUAL

HYDRAULIC EXCAVATOR

PC228USLC-10

Model Serial Number

PC228USLC- 1002 and up
10

00 Index and foreword

00 Index and foreword

Index

Index (ALL-0310-001-A-00-A)

00 Index and foreword	00-1
Index	00-2
Foreword, safety and general information	00-14
Important safety notice	00-14
How to read the shop manual	00-21
Explanation of terms for maintenance standard	00-23
Handling equipment of fuel system devices	00-25
Handling of intake system parts	00-26
Handling of hydraulic equipment	00-27
Method of disconnecting and connecting of push-pull type coupler	00-29
Handling of electrical equipment	00-32
How to read electric wire code	00-40
Precautions when performing operation	00-43
Practical use of KOMTRAX	00-48
Standard tightening torque table	00-49
List of abbreviation	00-55
Conversion table	00-60
01 Specification	01-1
Table of contents	01-2
Specifications	01-3
Specification drawing	01-3
Working range drawings	01-4
Specifications	01-5
Weight table	01-8
Table of fuel, coolant, and lubricants	01-10
10 Structure and function	10-1
Table of contents	10-2
Engine and cooling system	10-3
Engine related parts	10-3
KVTG	10-5
EGR system piping drawing	10-12
EGR system circuit diagram	10-14
EGR valve	10-16
EGR cooler	10-18
KCCV layout drawing	10-19
KCCV ventilator	10-21
KDPF	10-23
Cooling system	10-27
Power train	10-29
Power train system	10-29
Swing circle	10-31
Swing machinery	10-32
Final drive	10-34
Undercarriage and frame	10-36
Track frame and idler cushion	10-36
Hydraulic system	10-38
Hydraulic component layout	10-38
Valve control	10-40
Hydraulic tank	10-41
CLSS	10-43
Main pump	10-48
Control valve	10-79
Swing motor	10-135
Travel motor	10-147
PPC valve	10-160
Solenoid valve	10-183
Attachment circuit selector valve (for high pressure circuit)	10-187

Attachment circuit selector valve (for low pressure circuit).....	10-190
Center swivel joint.....	10-193
Accumulator.....	10-195
Work equipment.....	10-197
Work equipment.....	10-197
Work equipment shim.....	10-198
Bucket play adjustment shim.....	10-199
Cab and its attachments.....	10-200
Cab mount and cab tipping stopper.....	10-200
ROPS cab.....	10-201
Electrical system.....	10-202
Electrical control system.....	10-202
Machine monitor system.....	10-257
KOMTRAX system.....	10-279
Sensor.....	10-282
20 Standard value tables.....	20-1
Table of contents.....	20-2
Standard service value table.....	20-3
Standard value table for engine.....	20-3
Standard value table for machine.....	20-4
Standard value table for electrical system.....	20-18
30 Testing and adjusting.....	30-1
Table of contents.....	30-2
Related information on testing and adjusting.....	30-3
Tools for testing and adjusting.....	30-3
Sketch of tools for testing and adjusting.....	30-7
Engine and cooling system.....	30-8
Testing engine speed.....	30-8
Testing boost pressure.....	30-9
Testing exhaust gas color.....	30-11
Testing and adjusting valve clearance.....	30-13
Testing compression pressure.....	30-16
Testing blowby pressure.....	30-20
Testing engine oil pressure.....	30-21
Testing EGR valve and KVGT oil pressures.....	30-22
Measuring fuel pressure.....	30-23
Measuring fuel delivery, return and leakage.....	30-29
Bleeding air from fuel system.....	30-34
Testing fuel circuit for leakage.....	30-36
Handling cylinder cutout mode operation.....	30-37
Handling no-injection cranking operation.....	30-38
Testing and adjusting air conditioner compressor belt tension.....	30-39
Replacing fan belt.....	30-41
Power train.....	30-42
Testing swing circle bearing clearance.....	30-42
Undercarriage and frame.....	30-43
Testing and adjusting track tension.....	30-43
Hydraulic system.....	30-44
Releasing remaining pressure from hydraulic circuit.....	30-44
Testing and adjusting oil pressure in work equipment, swing, and travel circuits.....	30-49
Testing oil pressure of control circuit.....	30-53
Testing and adjusting oil pressure in pump PC control circuit.....	30-54
Testing and adjusting oil pressure in pump LS control circuit.....	30-58
Testing outlet pressure of solenoid valve.....	30-66
Testing PPC valve outlet pressure.....	30-69
Adjusting play of work equipment and swing PPC valves.....	30-71
Testing pump swash plate sensor.....	30-72
Isolating the parts causing hydraulic drift in work equipment.....	30-73
Testing and adjusting travel deviation.....	30-75

Testing oil leakage	30-77
Bleeding air from hydraulic circuit	30-80
Work equipment	30-83
Testing and adjusting boom angle potentiometer	30-83
Cab and its attachments	30-84
Testing cab tipping stopper	30-84
Adjusting mirrors	30-85
Electrical system	30-87
Special functions of machine monitor	30-87
KOMTRAX terminal start-up procedure	30-157
Adjusting rearview camera angle	30-160
Handling voltage circuit of engine controller	30-162
Handling battery disconnect switch	30-163
Testing diodes	30-164
Pm clinic	30-165
Pm Clinic service	30-165
40 Troubleshooting	40-1
Table of contents	40-2
Related information on troubleshooting	40-9
Troubleshooting points	40-9
Sequence of events in troubleshooting	40-11
Testing before troubleshooting	40-13
Inspection procedure before troubleshooting	40-15
Preparation work for troubleshooting of electrical system	40-34
Classification and procedure for troubleshooting	40-39
Symptom of probable failure and troubleshooting No.	40-42
Information in troubleshooting table	40-45
Diagnostic procedure for wiring harness open circuit of pressure sensor system	40-47
Connector list and layout	40-49
Connector contact identification	40-60
T-branch box and T-branch adapter table	40-99
Fuse location table	40-104
Precautions for KDPF (KCSF and KDOC) Cleaning and Replacement	40-106
Preparation of dummy temperature sensor (for KDOC and KDPF temperature sensors)	40-109
Preparation of short circuit electrical connector (for failure codes [CA1883] and [CA3135])	40-110
Failure codes table	40-111
Troubleshooting by failure code (Display of code)	40-120
Failure code [879AKA] A/C Inner Sensor Open Circuit	40-120
Failure code [879AKB] A/C Inner Sensor Short Circuit	40-121
Failure code [879BKA] A/C Outer Sensor Open Circuit	40-122
Failure code [879BKB] A/C Outer Sensor Short Circuit	40-123
Failure code [879CKA] Ventilating Sensor Open Circuit	40-124
Failure code [879CKB] Ventilating Sensor Short Circuit	40-125
Failure code [879DKZ] Sunlight Sensor Open Or Short Circuit	40-126
Failure code [879EMC] Ventilation Damper Abnormality	40-127
Failure code [879FMC] Air Mix Damper Abnormality	40-128
Failure code [879GKX] Refrigerant Abnormality	40-129
Failure code [989L00] Engine Controller Lock Caution 1	40-130
Failure code [989M00] Engine Controller Lock Caution 2	40-131
Failure code [989N00] Engine Controller Lock Caution 3	40-132
Failure code [A1U0N3] HC Desorb Request 1	40-133
Failure code [A1U0N4] HC Desorb Request 2	40-135
Failure code [AA10NX] Air Cleaner Clogging	40-137
Failure code [AB00KE] Charge Voltage Low	40-139
Failure code [B@BAZG] Eng Oil Press Low	40-141
Failure code [B@BAZK] Eng Oil Level Low	40-142
Failure code [B@BCNS] Eng Water Overheat	40-143

Failure code [B@BCZK] Eng Water Level Low	40-144
Failure code [B@HANS] Hyd Oil Overheat	40-146
Failure code [CA115] Eng Ne and Bkup Speed Sens Error	40-147
Failure code [CA122] Chg Air Press Sensor High Error	40-148
Failure code [CA123] Chg Air Press Sensor Low Error	40-150
Failure code [CA131] Throttle Sensor High Error.....	40-152
Failure code [CA132] Throttle Sensor Low Error	40-154
Failure code [CA144] Coolant Temp Sens High Error	40-156
Failure code [CA145] Coolant Temp Sens Low Error	40-158
Failure code [CA153] Chg Air Temp Sensor High Error.....	40-160
Failure code [CA154] Chg Air Temp Sensor Low Error.....	40-162
Failure code [CA187] Sensor 2 Supply Volt Low Error	40-164
Failure code [CA221] Ambient Press Sensor High Error	40-166
Failure code [CA222] Ambient Press Sensor Low Error	40-168
Failure code [CA227] Sensor 2 Supply Volt High Error.....	40-170
Failure code [CA234] Eng Overspeed	40-171
Failure code [CA238] Ne Speed Sensor Supply Volt Error	40-172
Failure code [CA239] Ne Speed Sens Supply Volt High Error.....	40-173
Failure code [CA271] IMV/PCV1 Short Error	40-174
Failure code [CA272] IMV/PCV1 Open Error	40-176
Failure code [CA295] Ambient Press Sens In Range Error.....	40-178
Failure code [CA322] Inj #1(L#1) Open/Short Error	40-179
Failure code [CA323] Inj #5(L#5) Open/Short Error	40-181
Failure code [CA324] Inj #3(L#3) Open/Short Error	40-183
Failure code [CA325] Inj #6(L#6) Open/Short Error	40-185
Failure code [CA331] Inj #2(L#2) Open/Short Error	40-187
Failure code [CA332] Inj #4(L#4) Open/Short Error	40-189
Failure code [CA343] ECM Critical Internal Failure	40-191
Failure code [CA351] Injectors Drive Circuit Error	40-192
Failure code [CA352] Sensor 1 Supply Volt Low Error	40-193
Failure code [CA356] Mass Air Flow Sensor High Error	40-195
Failure code [CA357] Mass Air Flow Sensor Low Error.....	40-197
Failure code [CA386] Sensor 1 Supply Volt High Error.....	40-199
Failure code [CA428] Water in Fuel Sensor High Error	40-200
Failure code [CA429] Water in Fuel Sensor Low Error	40-202
Failure code [CA435] Eng Oil Press Sw Error	40-204
Failure code [CA441] Battery Voltage Low Error	40-205
Failure code [CA442] Battery Voltage High Error.....	40-207
Failure code [CA449] Rail Press Very High Error.....	40-208
Failure code [CA451] Rail Press Sensor High Error.....	40-209
Failure code [CA452] Rail Press Sensor Low Error	40-211
Failure code [CA488] Chg Air Temp High Torque Derate.....	40-213
Failure code [CA515] Rail Press Sens Sup Volt High Error	40-214
Failure code [CA516] Rail Press Sens Sup Volt Low Error	40-216
Failure code [CA553] Rail Press High Error	40-218
Failure code [CA555] Crankcase Press High Error 1	40-219
Failure code [CA556] Crankcase Press High Error 2	40-220
Failure code [CA559] Rail Press Low Error.....	40-221
Failure code [CA595] Turbo Speed High Error 2	40-223
Failure code [CA687] Turbo Speed Low Error.....	40-224
Failure code [CA689] Eng Ne Speed Sensor Error.....	40-226
Failure code [CA691] Intake Air Temp Sens High Error.....	40-228
Failure code [CA692] Intake Air Temp Sens Low Error.....	40-230
Failure code [CA697] ECM Int Temp Sensor High Error	40-232
Failure code [CA698] ECM Int Temp Sensor Low Error.....	40-233
Failure code [CA731] Eng Bkup Speed Sens Phase Error	40-234
Failure code [CA778] Eng Bkup Speed Sensor Error.....	40-236
Failure code [CA1117] Persistent Data Lost Error.....	40-241
Failure code [CA1664] KDOC Malfunction.....	40-242

00 Index and foreword

Index

Failure code [CA1691] Regeneration Ineffective	40-244
Failure code [CA1695] Sensor 5 Supply Volt High Error	40-247
Failure code [CA1696] Sensor 5 Supply Volt Low Error	40-249
Failure code [CA1843] Crankcase Press Sens High Error	40-251
Failure code [CA1844] Crankcase Press Sens Low Error	40-253
Failure code [CA1879] KDPF Delta P Sensor High Error	40-255
Failure code [CA1881] KDPF Delta P Sensor Low Error	40-257
Failure code [CA1883] KDPF Delta P Sens In Range Error	40-259
Failure code [CA1921] KDPF Soot Load High Error 1	40-262
Failure code [CA1922] KDPF Soot Load High Error 2	40-265
Failure code [CA1942] Crankcase Press Sens In Range Error	40-270
Failure code [CA1993] KDPF Delta Pressure Low Error	40-271
Failure code [CA2185] Throt Sensor Sup Volt High Error	40-274
Failure code [CA2186] Throt Sensor Sup Volt Low Error	40-276
Failure code [CA2249] Rail Press Very Low Error	40-278
Failure code [CA2271] EGR Valve Pos Sens High Error	40-279
Failure code [CA2272] EGR Valve Pos Sens Low Error	40-281
Failure code [CA2288] Turbo Speed High Error 1	40-284
Failure code [CA2311] IMV Solenoid Error	40-285
Failure code [CA2349] EGR Valve Solenoid Open Error	40-286
Failure code [CA2353] EGR Valve Solenoid Short Error	40-288
Failure code [CA2357] EGR Valve Servo Error	40-290
Failure code [CA2373] Exhaust Manifold Press Sens High error	40-291
Failure code [CA2374] Exhaust Manifold Press Sens Low error	40-293
Failure code [CA2375] EGR Orifice Temp Sens High Error	40-295
Failure code [CA2376] EGR Orifice Temp Sens Low Error	40-297
Failure code [CA2381] KVGT Pos Sens High Error	40-299
Failure code [CA2382] KVGT Pos Sens Low Error	40-301
Failure code [CA2383] KVGT Solenoid Open Error	40-304
Failure code [CA2386] KVGT Solenoid Short Error	40-306
Failure code [CA2387] KVGT Servo Error	40-308
Failure code [CA2554] Exh Manifold Press Sens In Range Error	40-309
Failure code [CA2555] Grid Htr Relay Volt Low Error	40-310
Failure code [CA2556] Grid Htr Relay Volt High Error	40-312
Failure code [CA2637] KDOC Face Plugging	40-314
Failure code [CA2639] Manual Stationary Regeneration Request	40-316
Failure code [CA2961] EGR Orifice Temp High Error 1	40-319
Failure code [CA2973] Chg Air Press Sensor In Range Error	40-320
Failure code [CA3133] KDPF Outlet Press Sens High Error	40-321
Failure code [CA3134] KDPF Outlet Press Sens Low Error	40-323
Failure code [CA3135] KDPF Outlet Press Sens In Range Error	40-325
Failure code [CA3251] KDOC Inlet Temp High Error	40-329
Failure code [CA3253] KDOC Temp Error - Non Regeneration	40-332
Failure code [CA3254] KDOC Outlet Temp High Error 1	40-335
Failure code [CA3255] KDPF Temp Error - Non Regeneration	40-338
Failure code [CA3256] KDPF Outlet Temp High Error 1	40-341
Failure code [CA3311] KDOC Outlet Temp High Error 2	40-344
Failure code [CA3312] KDPF Outlet Temp High Error 2	40-347
Failure code [CA3313] KDOC Inlet Temp Sensor Low Error	40-350
Failure code [CA3314] KDOC Inlet Temp Sens High Error	40-353
Failure code [CA3315] KDOC Inlet Temp Sens In Range Error	40-357
Failure code [CA3316] KDOC Outlet Temp Sens Low Error	40-361
Failure code [CA3317] KDOC Outlet Temp Sens High Error	40-364
Failure code [CA3318] KDOC Outlet Temp Sens In Range Error	40-368
Failure code [CA3319] KDPF Outlet Temp Sens High Error	40-372
Failure code [CA3321] KDPF Outlet Temp Sens Low Error	40-376
Failure code [CA3322] KDPF Outlet Temp Sens In Range Error	40-379
Failure code [CA3419] Mass Air Flow Sensor Sup Volt High Error	40-383
Failure code [CA3421] Mass Air Flow Sensor Sup Volt Low Error	40-385

Failure code [CA3741] Rail Press Valve Trip Error.....	40-387
Failure code [D110KB] Battery Relay Drive Short Circuit.....	40-388
Failure code [D19JKZ] Personal Code Relay Abnormality.....	40-390
Failure code [D811MC] KOMTRAX Error.....	40-393
Failure code [D862KA] GPS Antenna Open Circuit	40-394
Failure code [D8ALKA] System Operating Lamp Disconnection (KOMTRAX).....	40-395
Failure code [D8ALKB] System Operating Lamp Short Circuit (KOMTRAX)	40-397
Failure code [D8AQKR] CAN2 Discon (KOMTRAX)	40-398
Failure code [DA20MC] Pump Controller.....	40-399
Failure code [DA22KK] Pump Solenoid Power Low Error.....	40-400
Failure code [DA25KP] 5V Sensor 1 Power Abnormality.....	40-402
Failure code [DA26KP] 5V Sensor 2 Power Abnormality.....	40-405
Failure code [DA29KQ] Model Selection Abnormality	40-406
Failure code [DA2LKA] System Operating Lamp Disconnection (Pump Con)	40-408
Failure code [DA2LKB] System Operating Lamp Short Circuit (Pump Con)	40-410
Failure code [DA2QKR] CAN2 Discon (Pump Con).....	40-411
Failure code [DA2RKR] CAN1 Discon (Pump Con)	40-413
Failure code [DAF0MB] Monitor ROM Abnormality.....	40-414
Failure code [DAF0MC] Monitor Error	40-415
Failure code [DAF8KB] Camera Power Supply Short Circuit	40-416
Failure code [DAF9KQ] Model Selection Abnormality	40-418
Failure code [DAFGMC] GPS Module Error.....	40-419
Failure code [DAFLKA] Operating Lamp Open Circuit(Monitor)	40-420
Failure code [DAFLKB] System Operating Lamp Short Circuit (Monitor).....	40-422
Failure code [DAFQKR] CAN2 Discon (Monitor)	40-423
Failure code [DAZ9KQ] A/C Model Selection Abnormality.....	40-424
Failure code [DAZQKR] CAN2 Discon (Aircon ECU)	40-425
Failure code [DB2QKR] CAN2 Discon (Engine Con)	40-429
Failure code [DB2RKR] CAN1 Discon (Engine Con)	40-433
Failure code [DGH2KB] Hyd Oil Sensor Short Circuit	40-437
Failure code [DHA4KA] Air Cleaner Clog Sensor Open Circuit	40-439
Failure code [DHPAMA] F Pump Press Sensor Abnormality.....	40-440
Failure code [DHPBMA] R Pump Press Sensor Abnormality	40-443
Failure code [DHS3MA] Arm IN PPC Sen. Abnormality	40-446
Failure code [DHS4MA] Bucket Curl PPC Press Sensor Abnormality	40-448
Failure code [DHS8MA] Boom Raise PPC Press Sensor Abnormality.....	40-451
Failure code [DHS9MA] Boom LOWER Press Sensor Abnormality.....	40-454
Failure code [DHSAMA] Swing RH PPC Press Sensor Abnormality	40-457
Failure code [DHSBMA] Swing LH PPC Press Sensor Abnormality	40-460
Failure code [DHSCMA] Arm Dump PPC Press Sensor Abnormality	40-463
Failure code [DHSDMA] Bucket Dump PPC Press Sensor Abnormality	40-466
Failure code [DHSFMA] Travel Fwd LH PPC Press Sensor Abnormality	40-469
Failure code [DHSGMA] Travel Fwd RH PPC Press Sensor Abnormality	40-472
Failure code [DHSHMA] Travel Rev LH PPC Press Sensor Abnormality	40-475
Failure code [DHSJMA] Travel Rev RH PPC Press Sensor Abnormality	40-478
Failure code [DKA0KA] Failure of Boom Angle Sensor (Open circuit)	40-481
Failure code [DKA0KB] Failure of Boom Angle Sensor (Short circuit).....	40-483
Failure code [DKA0PH] Boom Angle Sensor installation error	40-485
Failure code [DKR0MA] F Pump Swash Plate Sensor Abnormality	40-486
Failure code [DKR1MA] R Pump Swash Plate Sensor Abnormality	40-488
Failure code [DR21KX] Camera 2 Picture Rev. Drive Abnormality	40-490
Failure code [DR31KX] Camera 3 Picture Rev. Drive Abnormality	40-492
Failure code [DV20KB] Travel Alarm Short Circuit.....	40-494
Failure code [DW43KA] Travel Speed Sol Open Circuit	40-496
Failure code [DW43KB] Travel Speed Sol Short Circuit	40-498
Failure code [DW45KA] Swing Brake Sol Open Circuit	40-500
Failure code [DW45KB] Swing Brake Sol Short Circuit	40-503
Failure code [DW4GKA] Boom slow down EPC sol disconnection.....	40-505
Failure code [DW4GKB] Boom slow down EPC sol short circuit	40-507

Failure code [DW91KA] Travel Junction Sol Open Circuit	40-509
Failure code [DW91KB] Travel Junction Sol Short Circuit.....	40-511
Failure code [DWA2KA] Attachment Sol Open Circuit.....	40-513
Failure code [DWA2KB] Attachment Sol Short Circuit.....	40-515
Failure code [DWK0KA] 2-Stage Relief Sol Open Circuit	40-517
Failure code [DWK0KB] 2-Stage Relief Sol Short Circuit.....	40-519
Failure code [DWK2KA] Variable Back Press Sol Open Circuit.....	40-521
Failure code [DWK2KB] Variable Back Press Sol Short Circuit.....	40-523
Failure code [DWK8KA] Swing Press C/O Sol Open Circuit	40-525
Failure code [DWK8KB] Swing Press C/O Sol Short Circuit	40-527
Failure code [DXA8KA] PC-EPC (F) Sol Open Circuit.....	40-529
Failure code [DXA8KB] PC-EPC (F) Sol Short Circuit.....	40-531
Failure code [DXA9KA] PC-EPC (R) Sol Open Circuit	40-533
Failure code [DXA9KB] PC-EPC (R) Sol Short Circuit	40-535
Failure code [DXE0KA] LS-EPC Sol Open Circuit	40-537
Failure code [DXE0KB] LS-EPC Sol Short Circuit	40-539
Failure code [DXE4KA] Attachment Flow EPC Open Circuit	40-541
Failure code [DXE4KB] Attachment Flow EPC Short Circuit.....	40-543
Failure code [DXE5KA] Merge-divide Main Sol Open Circuit	40-545
Failure code [DXE5KB] Merge-divide Main Sol Short Circuit	40-547
Failure code [DXE6KA] Merge-divide LS Sol Open Circuit	40-549
Failure code [DXE6KB] Merge-divide LS Sol Short Circuit	40-551
Failure code [DY20KA] Wiper Working Abnormality	40-553
Failure code [DY20MA] Wiper Parking Abnormality.....	40-555
Failure code [DY2CKB] Washer Drive Short Circuit.....	40-557
Failure code [DY2DKB] Wiper Drive (Fwd) Short Circuit	40-559
Failure code [DY2EKB] Wiper Drive (Rev) Short Circuit.....	40-561
Troubleshooting of electrical system (E-mode)	40-563
E-1 Engine does not start (Engine does not crank).....	40-563
E-2 Manual preheating system does not work.....	40-568
E-3 Automatic preheating system does not work.....	40-571
E-4 While preheating is working, preheating monitor does not light up	40-573
E-5 When starting switch is turned to ON position, machine monitor displays nothing.....	40-575
E-6 While starting switch is turned to ON position (with engine stopped), engine oil level monitor lights up in yellow.....	40-578
E-7 While starting switch is turned to ON position (with engine stopped), radiator coolant level monitor lights up in yellow.....	40-579
E-8 Engine coolant temperature monitor lights up in red while engine is running	40-580
E-9 Hydraulic oil temperature monitor lights up in white while engine is running	40-581
E-10 Charge level monitor lights up in red while engine is running	40-582
E-11 Fuel level monitor lights up in red while engine is running.....	40-583
E-12 Air cleaner clogging monitor lights up in yellow while engine is running	40-584
E-13 Water separator monitor lights up in red while engine is running	40-585
E-14 Engine coolant temperature monitor lights up in red while engine is running	40-586
E-15 Hydraulic oil temperature monitor lights up in red while engine is running	40-587
E-16 Engine oil pressure monitor lights up in red while engine is running	40-588
E-17 Fuel gauge display does not move from minimum or maximum	40-589
E-18 Fuel gauge indicates incorrect amount (indicates neither full nor empty).....	40-590
E-19 Engine coolant temperature gauge display does not move from minimum or maximum	40-591
E-20 Engine coolant temperature gauge indicates incorrect temperature (indicates neither full nor empty).....	40-592
E-21 Hydraulic oil temperature gauge does not move from minimum or maximum	40-593
E-22 Hydraulic oil temperature gauge indicates incorrect temperature (indicates neither full nor empty)	40-595
E-23 Contents of display on machine monitor is different from actual machine condition	40-596
E-24 Some areas of machine monitor screen are not displayed.....	40-597
E-25 Function switch does not work.....	40-598

E-26 Automatic warm-up system does not operate (in cold season).....	40-599
E-27 Auto-deceleration monitor does not light up, or does not go out, while auto-deceleration switch is operated	40-600
E-28 Auto-deceleration function does not operate or is not canceled while lever is operated	40-601
E-29 Working mode selection screen is not displayed while working mode selector switch is operated	40-602
E-30 Setting of engine and hydraulic pump is not changed while working mode is changed.....	40-603
E-31 Travel speed monitor does not change when travel speed switch is operated	40-604
E-32 Travel speed does not change while travel speed selection is changed	40-605
E-33 Alarm buzzer does not stop sounding.....	40-606
E-34 Service meter is not displayed, while starting switch is in OFF position.....	40-607
E-35 Service mode cannot be selected	40-608
E-36 Any of work equipment, swing and travel does not work.....	40-609
E-37 Any of work equipment, swing and travel cannot be locked	40-611
E-38 Upper structure does not swing while swing parking brake cancel switch is set to CANCEL position.....	40-613
E-39 Swing brake does not operate while swing parking brake cancel switch is set to NORMAL position	40-615
E-40 One-touch power maximizing function does not operate, or indicator is not displayed on monitor	40-617
E-41 One-touch power maximizing function cannot be canceled	40-619
E-42 Alarm does not sound during travel	40-620
E-43 Alarm does not stop sounding while machine is stopped	40-622
E-44 Horn does not sound	40-623
E-45 Horn does not stop sounding.....	40-625
E-46 Wiper monitor does not light up, or does not go out, while wiper switch is operated	40-626
E-47 Wiper does not operate while wiper switch is operated	40-627
E-48 Window washer does not operate while window washer switch is operated	40-629
E-49 Boom LOWER is not displayed correctly with monitoring function	40-630
E-50 Arm OUT is not displayed correctly with monitoring function	40-631
E-51 Arm IN is not displayed correctly with monitoring function	40-632
E-52 Boom RAISE is not displayed correctly with monitoring function	40-633
E-53 Bucket CURL is not displayed correctly with monitoring function.....	40-634
E-54 Bucket DUMP is not displayed correctly with monitoring function	40-635
E-55 Swing is not displayed correctly with monitoring function.....	40-636
E-56 Travel is not displayed correctly with monitoring function	40-637
E-57 Service is not displayed correctly with monitoring function	40-638
E-58 Attachment hydraulic circuit cannot be changed.....	40-640
E-59 KOMTRAX system does not operate normally	40-641
Troubleshooting of hydraulic and mechanical system (H-mode).....	40-643
Information described in troubleshooting table (H-mode)	40-643
System chart of hydraulic and mechanical systems.....	40-644
Failure mode and cause table	40-646
H-1 All of work equipment, swing and travel operation lacks speed or power	40-654
H-2 Engine speed drops significantly or engine stalls	40-657
H-3 All work equipment, swing and travel does not work	40-660
H-4 Unusual sound is heard from around hydraulic pump	40-661
H-5 Fine control performance or response is poor	40-662
H-6 Boom speed or power is low	40-664
H-7 Arm speed or power is low	40-668
H-8 Bucket speed or power is low	40-672
H-9 Work equipment does not move in single operation.....	40-675
H-10 Hydraulic drift of boom is large	40-676
H-11 Hydraulic drift of arm is large	40-677
H-12 Hydraulic drift of bucket is large	40-678
H-13 Time lag of work equipment is large	40-679

H-14	When part of work equipment is relieved singly, other parts of work equipment move	40-681
H-15	One-touch power maximizing function does not operate	40-682
H-16	In combined operation of work equipment, equipment having heavier load moves slower	40-683
H-17	In combined operations of swing and boom RAISE, boom rising speed is low	40-684
H-18	In combined operations of swing and travel, travel speed drops largely	40-685
H-19	Machine does not travel straight	40-686
H-20	Travel speed is slow	40-689
H-21	Machine is hard to steer or travel power is low	40-691
H-22	Travel speed does not change, or travel speed is too slow or fast	40-694
H-23	One of tracks does not run	40-695
H-24	Upper structure does not swing to the right or left	40-697
H-25	Upper structure swing only to the right or left	40-698
H-26	Swing acceleration or swing speed is low in both directions (right and left)	40-699
H-27	Swing acceleration performance is poor or swing speed is slow in only one direction	40-700
H-28	Upper structure overruns excessively when it stops swinging (both right and left)	40-701
H-29	Upper structure overruns excessively when it stops swinging (either right or left)	40-702
H-30	Shock is large when upper structure stops swinging	40-703
H-31	Large unusual noise is heard when upper structure stops swinging	40-704
H-32	Swing drift on a slope is large while swing holding brake is applied	40-705
H-33	Swing drift on a slope is large while swing holding brake is released	40-706
H-34	Attachment hydraulic circuit cannot be changed while attachment is installed	40-707
H-35	Oil flow in attachment circuit cannot be controlled	40-708
Troubleshooting of engine (S-mode)		40-709
Information mentioned in troubleshooting table (S mode)		40-709
S-1	When starting switch is turned to START position, engine does not crank	40-710
S-2	Engine cranks but no exhaust smoke comes out	40-711
S-3	Fuel is being injected but engine does not start (misfiring: engine cranks but does not start)	40-712
S-4	Engine startability is poor	40-713
S-5	Engine does not pick up smoothly	40-715
S-6	Engine stops during operation	40-717
S-7	Engine runs rough or is unstable	40-719
S-8	Engine lacks power	40-720
S-9	Exhaust smoke is black (KDPF clogs up early)	40-722
S-10	Engine oil consumption is excessive	40-724
S-11	Engine oil becomes contaminated early	40-725
S-12	Fuel consumption is excessive	40-726
S-13	Oil is in coolant (or coolant spurts or coolant level goes down)	40-727
S-14	Engine oil pressure drops	40-728
S-15	Fuel is contaminated in engine oil	40-729
S-16	Coolant is contaminated in engine oil (Oil becomes cloudy white)	40-730
S-17	Coolant temperature rises too high (overheating)	40-731
S-18	Unusual noise is heard	40-732
S-19	Vibration is excessive	40-733
S-20	Air cannot be bled from fuel circuit	40-734
S-21	Active regeneration is executed frequently	40-735
S-22	Active regeneration takes time	40-736
S-23	White smoke is exhausted during active regeneration	40-737
50	Disassembly and assembly	50-1
	Table of contents	50-2
	Related information on disassembly and assembly	50-4
	How to read this manual	50-4
	Coating materials list	50-6
	Special tools list	50-10
	Sketches of special tools	50-16

Engine and cooling system	50-22
Removal and installation of supply pump assembly	50-22
Removal and installation of injector assembly	50-27
Removal and installation of cylinder head assembly	50-36
Removal and installation of radiator assembly	50-57
Removal and installation of hydraulic oil cooler assembly	50-60
Removal and installation of aftercooler assembly	50-64
Removal and installation of engine assembly	50-66
Removal and installation of engine front oil seal	50-75
Removal and installation of engine rear oil seal	50-80
Removal and installation of fuel cooler assembly	50-83
Removal and installation of fuel tank assembly	50-85
Removal and installation of engine hood assembly	50-87
Removal and installation of KDPF assembly	50-89
Disassembly and assembly of KDPF assembly	50-98
Removal and installation of KCCV assembly	50-106
Removal and installation of air cleaner assembly	50-109
Removal and installation of EGR (Exhaust Gas Recirculation) valve assembly	50-111
Removal and installation of EGR (Exhaust Gas Recirculation) cooler assembly	50-113
Power train	50-115
Removal and installation of travel motor and final drive assembly	50-115
Disassembly and assembly of final drive	50-116
Removal and installation of swing motor and swing machinery assembly	50-125
Disassembly and assembly of swing machinery assembly	50-127
Removal and installation of swing circle assembly	50-134
Undercarriage and frame	50-135
Separation and connection of track shoe assembly	50-135
Removal and installation of sprocket	50-138
Removal and installation of idler and idler cushion assembly	50-139
Disassembly and assembly of idler assembly	50-140
Disassembly and assembly of idler cushion assembly	50-143
Disassembly and assembly of track roller assembly	50-145
Disassembly and assembly of carrier roller assembly	50-147
Removal and installation of revolving frame assembly	50-150
Removal and installation of counterweight assembly	50-153
Removal and installation of counterweight assembly for maintenance	50-156
Hydraulic system	50-157
Removal and installation of center swivel joint assembly	50-157
Disassembly and assembly of center swivel joint assembly	50-159
Removal and installation of hydraulic tank assembly	50-161
Removal and installation of main pump assembly	50-164
Removal and installation of main pump input shaft oil seal	50-169
Removal and installation of control valve assembly	50-170
Disassembly and assembly of control valve assembly	50-177
Disassembly and assembly of work equipment PPC valve assembly	50-182
Disassembly and assembly of travel PPC valve assembly	50-184
Work equipment	50-186
Removal and installation of work equipment assembly	50-186
Disassembly and assembly of work equipment cylinder assembly	50-189
Cab and its attachments	50-197
Removal and installation of operator's cab assembly	50-197
Removal and installation of operator's cab glass (adhered glass)	50-200
Removal and installation of front window assembly	50-215
Removal and installation of floor frame assembly	50-221
Removal and installation of air conditioner unit assembly	50-227
Removal and installation of operator's seat	50-232
Removal and installation of seat belt	50-233
Removal and installation of front wiper assembly	50-234
Removal and installation of air conditioner compressor assembly	50-240

00 Index and foreword

Index

Removal and installation of air conditioner condenser assembly	50-242
Electrical system	50-244
Removal and installation of engine controller assembly	50-244
Removal and installation of pump controller assembly	50-245
Removal and installation of machine monitor assembly	50-248
Removal and installation of pump swash plate sensor	50-250
Removal and installation of mass air flow and temperature sensor	50-251
Removal and installation of KOMTRAX terminal	50-252
60 Maintenance standard	60-1
Table of contents	60-2
Engine and cooling system	60-3
Engine mount	60-3
Cooling system	60-4
Power train	60-5
Swing circle	60-5
Swing machinery	60-6
Final drive	60-8
Sprocket	60-10
Undercarriage and frame	60-12
Track frame and idler cushion	60-12
Idler	60-14
Track roller	60-16
Carrier roller	60-17
Track shoe	60-18
Hydraulic system	60-24
Hydraulic tank	60-24
Main pump	60-25
Control valve	60-26
Swing motor	60-36
Travel motor	60-38
PPC valve	60-41
Solenoid valve	60-51
Attachment circuit selector valve (for high-pressure circuit)	60-52
Attachment circuit selector valve (for low-pressure circuit)	60-53
Center swivel joint	60-54
Work equipment	60-55
Work equipment	60-55
Work equipment cylinder	60-64
80 Appendix	80-1
Table of contents	80-2
Air conditioner components	80-3
Precautions for refrigerant	80-3
Air conditioner component	80-4
Configuration and function of refrigeration cycle	80-7
Outline of refrigeration cycle	80-8
Air conditioner unit	80-10
Dual pressure switch	80-15
Air conditioner controller	80-16
Compressor	80-17
Air conditioner condenser	80-18
Sunlight sensor	80-20
Outer temperature sensor (outside air temperature sensor)	80-21
Procedure for testing and troubleshooting	80-22
Circuit diagram and arrangement of connector pins	80-24
System diagram	80-26
Input and output signals of the air conditioner controller	80-27
Air conditioner unit	80-29
Parts and connectors layout	80-31
Testing air leakage (duct)	80-37

Testing with self-diagnosis function	80-40
Testing vent (mode) changeover.....	80-43
Testing FRESH/RECIRC air changeover.....	80-44
Testing sunlight sensor	80-45
Testing (dual) pressure switch for refrigerant.....	80-46
Testing relays	80-48
Troubleshooting chart 1	80-49
Troubleshooting chart 2	80-50
Information in troubleshooting table	80-53
Failure code list related to air conditioner.....	80-54
Failure code [879AKA] A/C Inner Sensor Open Circuit	80-55
Failure code [879AKB] A/C Inner Sensor Short Circuit.....	80-56
Failure code [879BKA] A/C Outer Sensor Open Circuit.....	80-57
Failure code [879BKB] A/C Outer Sensor Short Circuit.....	80-59
Failure code [879CKA] Ventilating Sensor Open Circuit.....	80-61
Failure code [879CKB] Ventilating Sensor Short Circuit	80-62
Failure code [879DKZ] Sunlight Sensor Open or Short Circuit.....	80-63
Failure code [879EMC] Ventilation Damper Abnormality	80-65
Failure code [879FMC] Air Mix Damper Abnormality	80-66
Failure code [879GKX] Refrigerant Abnormality	80-67
A-1 Troubleshooting for power supply system (Air conditioner does not operate)	80-68
A-2 Troubleshooting for compressor and refrigerant system (Air is not cooled)	80-70
A-3 Troubleshooting for blower motor system (No air comes out or air flow is abnormal)	80-73
A-4 Troubleshooting for FRESH/RECIRC air changeover	80-75
Troubleshooting with gauge pressure.....	80-77
Connection of service tool.....	80-80
Precautions for disconnecting and connecting refrigerant piping.....	80-82
Handling of compressor oil.....	80-84
Desiccant replacement	80-86
90 Diagrams and drawings.....	90-1
Table of contents	90-2
Hydraulic circuit diagram	90-3
Symbols in hydraulic circuit diagram	90-3
Hydraulic circuit diagram.....	90-7
Electric circuit diagram	90-9
Symbols in electric circuit diagram	90-9
Electrical circuit diagram	90-13
Electrical circuit diagram of air conditioner unit.....	90-25
Index.....	1

Foreword, safety and general information (ALL-0370-001-A-00-A)

Important safety notice (ALL-1120-012-A-01-A)

(Rev. 2014/08)

- " Appropriate servicing and repair are extremely important to ensure safe operation of the machine. The shop manual describes the effective and safe servicing and repair methods recommended by Komatsu. Some of these methods require the use of the special tools designed by Komatsu for the specific purpose.
- " The symbol mark  is used for such matters that require special cautions during the work. The work indicated by the caution mark should be performed according to the instructions with special attention to the cautions. Should hazardous situation occur or be anticipated during such work, be sure to keep safe first and take every necessary measure.

Safety points

- " Good arrangement
- " Correct work clothes
- " Observance of work standard
- " Practice of making and checking signals
- " Prohibition of operation and handling by unlicensed workers
- " Safety check before starting work
- " Wearing protective goggles (for cleaning or grinding work)
- " Wearing shielding goggles and protectors (for welding work)
- " Good physical condition and preparation
- " Precautions against work which you are not used to or you are used to too much

General precautions

 **Inappropriate handling causes an extreme danger. Read and understand what is described in the operation and maintenance manual before operating the machine. Read and understand what is described in this manual before starting the work.**

- " Before performing any greasing or repairs, read all the safety labels stuck to the machine. For the locations of the safety labels and detailed explanation of precautions, see the operation and maintenance manual.
- " Locate a place in the repair workshop to keep the tools and removed parts. Always keep the tools and parts in their correct places. Always keep the work area clean and make sure that there is no dirt, water or oil on the floor. Smoke only in the areas provided for smoking. Never smoke while working.
- " When performing any work, always wear the safety shoes and helmet. Do not wear loose work clothes, or clothes with buttons missing.
 1. Always wear the protective eyeglasses when hitting parts with a hammer.
 2. Always wear the protective eyeglasses when grinding parts with a grinder, etc.
- " When performing any work with 2 or more workers, always agree on the working procedure

before starting. While working, always keep conversations of the work between your fellow workers and your self on any step of the work. During the work, hang the warning tag of "UNDER WORKING" in the operator's compartment.

- " Only qualified workers must perform the work and operation which require license or qualification.
- " Keep the tools in good condition. And learn the correct way to use the tools, and use the proper ones among them. Before starting the work, thoroughly check the tools, lift truck, service vehicle, etc.
- " If welding repairs is required, always have a trained and experienced welder with good knowledge of welding perform the work. When performing welding work, always wear welding gloves, apron, shielding goggles, cap, etc.
- " Before starting work, warm up your body thoroughly to start work under good condition.
- " Avoid continuing work for long hours and take rests with proper intervals to keep your body in good condition. Take a rest in a specified safe place.

Preparation

- " Before adding oil or making any repairs, place the machine on a firm and level ground, and apply the parking brake and chock the wheels or tracks to prevent the machine from moving.
- " Before starting work, lower the work equipment (blade, ripper, bucket, etc.) to the ground. If it is not possible to lower the equipment to the ground, insert the lock pin or use blocks to prevent the work equipment from falling. And be sure to lock all the work equipment control levers and hang a warning tag on them.
- " When performing the disassembling or assembling work, support the machine securely with blocks, jacks, or stands before starting the work.
- " Remove all of mud and oil from the steps or other places used to get on and off the machine completely. Always use the handrails, ladders of steps when getting on or off the machine. Never

jump on or off the machine. When the scaffold is not provided, use steps or stepladder to secure your footing.

Precautions during work

- " For the machine equipped with the battery disconnect switch, check that the system operating lamp is turned off before starting the work. Then, turn the battery disconnect switch to OFF (○) position and remove the switch key. For the machine not equipped with the battery disconnect switch, remove the cable from the battery before starting the work. Be sure to remove the negative end (-) of the battery cable first.
- " Release the remaining pressure in the circuits completely before the work when the parts in the circuits of oil, fuel, coolant and air are disconnected or removed. When the cap of the oil filter, drain plug or oil pressure pickup plug is removed, loose them slowly to prevent the oil from spurting out.
- " When removing or installing the checking plug or the piping in the fuel circuit, wait 30 seconds or longer after the engine is shut down and start the work after the remaining pressure is released from the fuel circuit.
- " Immediately after the engine is shut down, the coolant and oil in the circuits are hot. Be careful not to get scalded by the hot coolant and oil. Start the work after checking that the coolant and oil are cooled down sufficiently.
- " Start the work after the engine is shut down. Be sure to shut down the engine when working on or around the rotating parts in particular. When checking the machine without shutting down the engine (measuring oil pressure, rotational speed, oil or coolant temperature), take extreme care not to get caught in the rotating parts or the working equipment.
- " The hoist or crane must be used to sling the components weighing 25 kg or heavier. Check the slings (wire rope, nylon sling, chain and hook) for damage before the work. Use the slings with ample capacity and install them to the proper places. Operate the hoist or crane slowly to prevent the component from hitting any other part. Do not work with any part still raised by the hoist or crane.
- " When removing the part which is under internal pressure or reaction force of the spring, always leave 2 bolts in diagonal positions. Loosen those 2 bolts gradually and alternately and release the pressure, then, remove the part.
- " When removing the part, be careful not to break or damage the electrical wiring. The damaged wiring may cause electrical fires.
- " When removing piping, prevent the fuel or oil from spilling out. If any fuel or oil drips onto the floor, wipe it off immediately. Fuel or oil on the floor can cause you to slip and can even cause fires.
- " As a general rule, do not use gasoline to wash parts. Do not use gasoline to clean the electrical parts, in particular.
- " Reinstall the parts removed to their original places. Replace the damaged parts and the parts which must not be used with new ones. When installing the hoses and wiring harnesses, be careful that they are not damaged by contacting with other parts when the machine is operated.
- " When connecting the high pressure hoses and tubes, make sure that they are not twisted. The damaged high pressure hoses and tubes are very dangerous when they are installed. So, be extremely careful when connecting the high pressure pipings. In addition, check that their connections are correct.
- " When assembling or installing the parts, be sure to tighten the bolts to the specified torque. When installing the protective parts such as guards, or the parts which vibrate violently or rotate at high speeds, be sure to check that they are installed correctly.
- " When aligning 2 holes, never insert your fingers or hand into the holes. Align the holes with care so that your fingers are not caught in the hole.
- " When measuring hydraulic pressure, check that the measuring tools are correctly installed.
- " Pay attention to safety when removing and installing the tracks of the track type machines. When removing the track, it separates suddenly. The workers should not stand at either end of the track.
- " If the engine is operated for a long time in a closed place which is not ventilated well, you may suffer from gas poisoning. Accordingly, open the windows and doors to ventilate the place well.

Precautions for slinging work and making signals

- " Only one appointed worker must make signals and co-worker must communicate with each other frequently. The appointed signaler must make specified signals clearly at the place where the signaler is well seen from the operator's seat and where the signaler can see the working condition easily. The signaler must always stand in front of the load and guide the operator safely.
 1. Do not stand under the load.
 2. Do not step on the load.
- " Check the slings before starting sling work.
- " Keep putting on the gloves during sling work. (Put on the leather gloves, if available.)

00 Index and foreword

Foreword, safety and general information

- " Measure the weight of the load by the eye and check its center of gravity.
- " Use the proper sling according to the weight of the load and method of slinging. If too thick wire ropes are used to sling a light load, the load may slip and fall.
- " Do not sling a load with 1 wire rope only. If do so, the load may rotate or the sling gets loose and the sling may slip off. Install 2 or more wire ropes symmetrically.

⚠ Slinging with one rope may cause turning of the load during hoisting, untwisting of the rope, or slipping of the rope from its original slinging position on the load, which can result in a dangerous accident.

- " Hanging angle must be 60 deg. or smaller as a rule.
- " When hanging a heavy load (25kg or heavier), the hanging angle of the rope must be narrower than that of the hook.
- ★ When slinging a load with 2 ropes or more, the larger the hanging angle is, the larger the tension of each rope. The figure below shows the variation of allowable load in kg when hoisting is made with 2 ropes, each of which is allowed to sling up to 9.8 kN {1,000kg} a load vertically, at various hanging angles. When the 2 ropes sling a load vertically, up to 2,000 kg of total weight can be suspended. This weight is reduced to 1,000 kg when the 2 ropes make a hanging angle of 120 deg.. If the 2 ropes sling a 2,000 kg load at a hanging angle of 150 deg., each rope is subjected to a force as large as 4,000 kg.

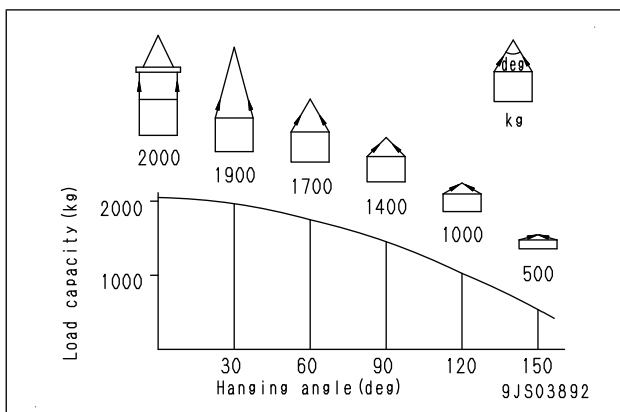

- " When installing wire ropes to an angular load, apply pads to protect the wire ropes. If the load is slippery, apply proper material to prevent the wire rope from slipping.
- " Use the specified eye bolts and fix wire ropes, chains, etc. to them with shackles, etc.
- " Apply wire ropes to the middle part of the hook.

- ★ Slinging near the tip of the hook may cause the rope to slip off the hook during hoisting. The strength of the hook is maximum at its central part.

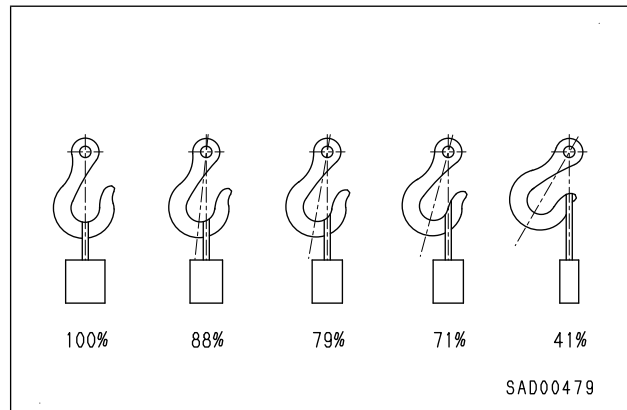

- " Do not use twisted or kinked wire ropes.
- " When slinging up a load, observe the following.
 1. Wind up the rope slowly until the wire rope tensions. When putting your hands on the wire ropes, do not grasp them but press them down from above. If you grasp them, your fingers may be caught.
 2. After the wire ropes are stretched, stop the crane and check the condition of the slung load, wire ropes, and pads.
 3. If the load is unstable or the wire rope or chains are twisted, lower the load and lift it up again.
 4. Do not lift up the load at an angle.
- " When lowering a load, pay attention to the following.
 1. When lifting down a load, stop it temporarily at 30 cm above the floor, and then lower it slowly.
 2. Check that the load is stable, and then remove the sling.
 3. Remove kinks and dirt from the wire ropes and chains used for the sling work, and put them in the specified place.

Precautions for using mobile crane

- ★ Read the Operation and Maintenance Manual of the crane carefully in advance and operate the crane safely.

Precautions for using overhead traveling crane

⚠ The hoist or crane must be used to sling the components weighing 25 kg or heavier. A part weighing 25 kg or heavier in "disassembly and assembly" section is indicated with the symbol of .

- " Before starting work, check the wire ropes, brake, clutch, controller, rails, over winding prevention device, ground fault circuit interrupter

for electric shock prevention, crane collision prevention device, and energizing warning lamp, and check the following safety items.

- " Observe the signals for sling work.
- " Operate the hoist at a safe place.
- " Be sure to check the directions of the direction indication plate (north, south, east and west) and the operating button.
- " Do not sling a load at an angle. Do not move the crane while the slung load is swinging.
- " Do not raise or lower a load while the crane is moving longitudinally or laterally.
- " Do not drag a sling.
- " When lifting up a load, stop it just after it leaves the ground and check safety, and then lift it up.
- " Consider the travel route in advance and lift up a load to a safe height.
- " Place the control switch in a position where it will not be an obstacle to work and passage.
- " After operating the hoist, do not swing the control switch.
- " Remember the position of the main switch so that you can turn off the power immediately in an emergency.
- " Shut down the main switch when the hoist stops because of a blackout. When turning on a switch which is turned OFF by the ground fault circuit interrupter for electric shock prevention, check that the devices related to that switch are not in operating condition.
- " If you find an obstacle around the hoist, stop the operation.
- " After finishing the work, stop the hoist at the specified position and raise the hook to at least 2 meters above the floor. Do not leave the sling attached to the hook.

Selecting wire ropes

- " Select adequate ropes depending on the weight of the parts to be hoisted, referring to the table below

Wire rope (JIS G3525, 6 x 37 - Type A)

(Standard Z twist wire ropes without galvanizing)

Nominal diameter of rope	Allowable load	
	kN	ton
mm		
10	8.8	0.9
12	12.7	1.3
14	17.3	1.7
16	22.6	2.3
18	28.6	2.9
20	35.3	3.6
25	55.3	5.6
30	79.6	8.1
40	141.6	14.4
50	221.6	22.6
60	318.3	32.4

- ★ The allowable load is calculated as one sixth of the breaking load of the rope to be used (safety coefficient: 6).

Precautions for disconnecting and connecting hoses and tubes in air conditioner circuit

Disconnection

⚠ When replacing the air conditioner unit, air conditioner compressor, condenser or receiver drier, etc., collect the refrigerant (air conditioner gas: R134a) from the air conditioner circuit before disconnecting the air conditioner hoses.

- ★ Ask a qualified person for collecting, adding and filling operations of the refrigerant (air conditioner gas: R134a). (Only registered persons can work.)

- ★ Never release the refrigerant (air conditioner gas: R134a) to the atmosphere.

⚠ If refrigerant gas (air conditioner gas: R134a) gets in your eyes, you may lose your sight. And if it touches your skin, you may suffer from frostbite. Put on protective eyeglasses, gloves and working clothes with long sleeves while collecting the refrigerant or filling the air conditioner circuit with the refrigerant.

- " When loosening the nuts fixing air conditioner hoses and tubes, be sure to use 2 wrenches; use one wrench to fix and use the other one to loosen the nut.

Connection

- " When installing the hose for the air conditioner circuit, take care not to allow invasion of dirt, dusts and water into the hose.
- " Check that the O-rings are fitted to the joints when connecting the air conditioner piping.
- " Once an O-ring is used, it is deformed and deteriorated. Accordingly, do not reuse it.
- " When removing the O-rings, use a soft tool so that the piping is not damaged.
- " Check that the O-ring is not damaged or deteriorated.
- " Apply compressor oil for refrigerant (R134a) to the O-ring.

- ★ However, do not apply oil to the threaded part of a bolt, nut or union.

Manufacturer	Part name
DENSO	ND-OIL8
VALEO THERMAL SYSTEMS	ZXL100PG (equivalent to PAG46)
SANDEN	SP-10

00 Index and foreword

Foreword, safety and general information

" When tightening nuts of the air conditioner hoses and tubes, be sure to use 2 wrenches. Use one wrench to fix and tighten the nut with the other wrench to the specified torque (Use a torque wrench for tightening).

★ Example of fitting of O-ring

" An O-ring is fitted to every joint of the air conditioner piping.

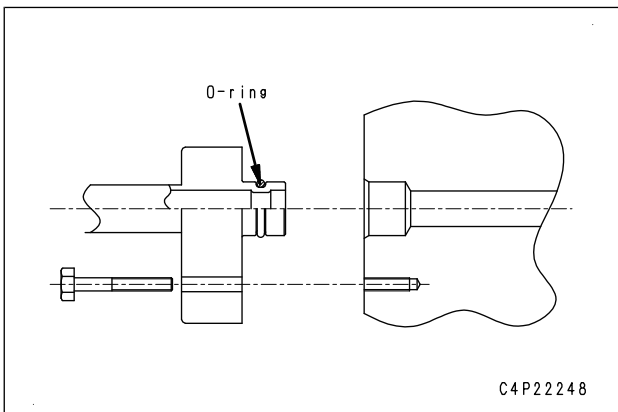
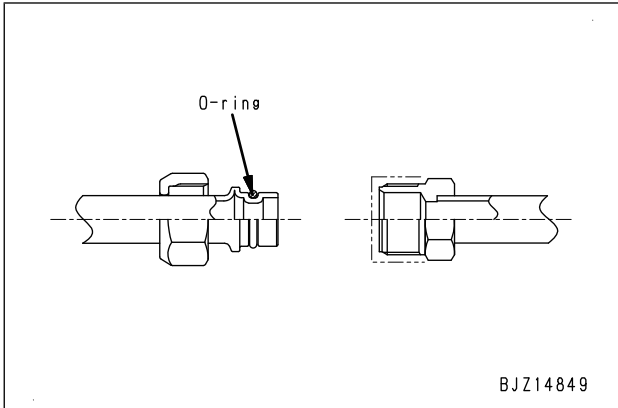

**For tightening torques, see "Others",
"Precautions for disconnection and connection
of air conditioner piping".**

Precautions to prevent fire (ALL-0000-17B-K-03-A)

" Fire caused by fuel, oil, coolant or window washer fluid

Do not bring any flame or fire close to flammable substances such as fuel, oil, coolant or window washer fluid. There is danger that they may catch fire. Always observe the following.

- " Do not smoke or use any flame near fuel or other flammable substances.
- " Shut down the engine before adding fuel.
- " Do not leave the machine when adding fuel or oil.
- " Tighten all the fuel and oil caps securely.
- " Be careful not to spill fuel on overheated surfaces or on parts of the electrical system.
- " After adding fuel or oil, wipe up any spilled fuel or oil.
- " Put greasy rags and other flammable materials into a safe container to maintain safety at the workplace.
- " When washing parts with oil, use a non-flammable oil. Do not use diesel oil or gasoline. There is danger that they may catch fire.
- " Do not weld or use a cutting torch to cut any pipes or tubes that contain flammable liquids.
- " Determine well-ventilated areas for storing oil and fuel. Keep the oil and fuel in the specified place and do not allow unauthorized persons to enter.
- " When performing grinding or welding work on the machine, move any flammable materials to a safe place before starting.

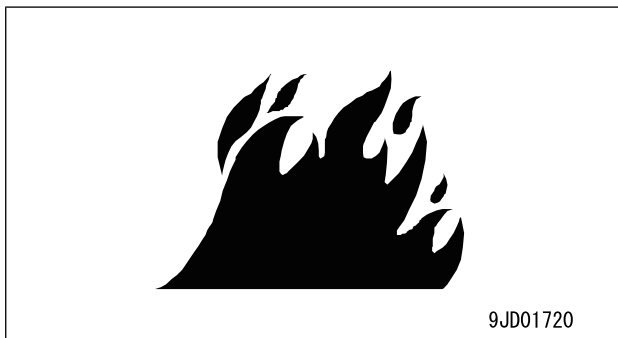

" Fire caused by accumulation or attachment of flammable material

- " Remove any dry leaves, chips, pieces of paper, coal dust, or any other flammable materials accumulated or attached to or around the engine exhaust manifold, muffler, or battery, or on the undercovers.
- " To prevent fires from being caught, remove any flammable materials such as dry leaves, chips, pieces of paper, coal dust, or any other flammable materials accumulated around the cooling system (radiator, oil cooler) or on the undercover.
- " **Fire coming from electric wiring**
Short circuits in the electrical system can cause fire. Always observe the following.
 - " Keep all the electric wiring connections clean and securely tightened.
 - " Check the wiring every day for looseness or damage. Reconnect any loose connectors or refasten wiring clamps. Repair or replace any damaged wiring.
- " **Fire caused by piping**
Check that all the clamps for the hoses and tubes, guards, and cushions are securely fixed in position.
If they are loose, they may vibrate during operation and rub against other parts. There is danger that this may lead to damage to the hoses and cause high-pressure oil to spurt out, leading to fire and serious personal injury or death.
- " **Fire around the machine due to highly heated exhaust gas**
Some machines are equipped with KDPF (Komatsu Diesel Particulate Filter). KDPF is a system for purifying soot in exhaust gas. Its exhaust gas discharged during purification process (regeneration) can be at higher temperature than that from existing models. Do not bring any flammable material close to the outlet of the exhaust pipe.
 - " When there are thatched houses, dry leaves or pieces of paper near the work site, set the system to disable the regeneration before starting work to prevent fire hazards due to highly heated exhaust gas.
See the operation and maintenance manual for the setting procedure.
- " **Explosion caused by lighting equipment**
 - " When checking fuel, oil, battery electrolyte, or coolant, always use lighting equipment with anti-explosion specifications.
 - " When taking the electrical power for the lighting equipment from the machine itself, follow the instructions in the operation and maintenance manual.

Actions if fire occurs (ALL-0000-17A-K-01-A)

- " Turn the starting switch to OFF position to stop the engine.
- " Use the handrails and steps to get off the machine.
- " Do not jump off the machine. You may fall or suffer serious injury.
- " The fume generated by a fire contains harmful materials which have a bad influence on a human body when they are sucked.
Don't breathe a fume.
- " After a fire, there may be harmful compounds left. If it touches your skin it may have a bad influence on your body.
Be sure to wear rubber gloves when handle the materials left after the fire.
The material of the gloves, which is recommended is polychloroprene (Neoprene) or polyvinyl chloride (in the lower temperature environment).
When wearing cotton-work-gloves, wear rubber gloves under them.

Dispose of waste materials (ALL-0000-99A-K-02-A)

To prevent pollution, pay full attention to the way to dispose of waste materials.

- " Always put the oil and coolant drained from the machine in containers. Never drain the oil and coolant directly onto the ground or dump into the sewage system, rivers, the sea, or lakes.
- " Observe the related laws and regulations when disposing of harmful objects such as oil, fuel, coolant, solvent, filters, and batteries.

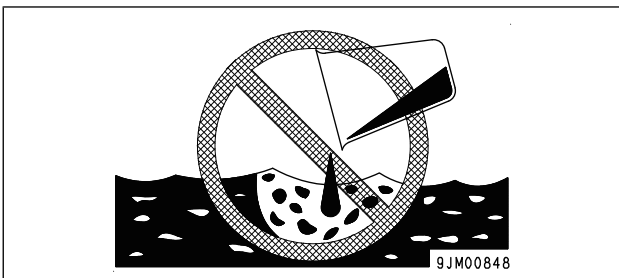

Some kinds of rubber and plastics may produce poisonous gas harmful to human body when they are burned.

- " As for rubber, plastics, or parts (hoses, cables, and wiring harnesses, etc.) which contain those materials, ask the industrial waste treatment firms for their disposals in accordance with the local regulations.

How to read the shop manual (ALL-0320-010-A-01-A)

(Rev. 2012/10)

- " Some attachments and optional parts described in this shop manual may not be arranged for certain areas. Contact your Komatsu distributor if one or some of them are required.
- " Materials and specifications are subject to change without notice.
- " The shop manuals are available for "Machine part" and "Engine part". For the engine, see the shop manual for the same model of the engine as the one which is mounted on the machine.

Composition of shop manual

- " This shop manual describes the technical information required for the services performed in a workshop. The shop manual is divided into the following chapters for the convenience of use.

00. Index and foreword

- " This section includes the index, foreword, safety and basic information.

01. Specification

- " This section explains the specifications of the machine.

10. Structure and function

- " This section explains the structure and function of the machine. The section of "Structure and function" serves not only to give an understanding for the structure of each component, but also serves as reference material for troubleshooting.

20. Standard value table

- " The standard values for a new machine and trouble shooting are indicated. This standard value table is used for testing and adjusting, and determining a failure at troubleshooting.

30. Testing and adjusting

- " This section describes the measuring tools and how to measure, and how to adjust various parts. As for the standard value and failure criterion, see the standard value table.

40. Troubleshooting

- " This section describes the troubleshooting in a suspected area when a failure occurs and the remedy for the failure. Troubleshooting is described by each failure mode.

50. Disassembly and assembly

- " This section explains the procedures for removing, installing, disassembling, and assembling each part or component and the special tools for the works as well as precautions for doing them safely. In addition, tightening torque, and quantity and weight of coating material, oil, grease, and coolant required for the works are also explained.

60. Maintenance standard

- " This section describes the maintenance standard values for each component. This section gives the criterion values for each component and required remedy at disassembly or maintenance.

80. Appendix

- " The structure and function, testing and adjusting, and troubleshooting for all of the other components or equipment which can not be separately classified are explained together in the appendix.

90. Diagrams and drawings







- " This section gives hydraulic circuit diagrams and electrical circuit diagrams.

00 Index and foreword

Foreword, safety and general information

Symbol

Important safety and quality portions are marked with the following symbols so that the shop manual is used practically.

Symbol	Item	Remarks
	Safety	The special safety precautions required for performing work are described.
	Caution	The special technical precautions or other precautions for preserving standards required when performing work are described.
	Weight	The weight of part or component and the cautions required when selecting hoisting wire or when working posture is important are indicated.
	Tightening torque	The tightening torques that require special attention during assembly work are indicated.
	Coat	The places to be coated with adhesives, grease, etc. during assembling are indicated.
	Oil, coolant	The places where oil, coolant, etc. must be added and the quantity to be added are indicated.
	Drain	Places where oil, coolant, etc. must be drained and the quantity to be drained are indicated.

Unit

- " In this shop manual, the units are indicated with International System of units (SI).
- " For reference, Gravitational System of units which is used to be used is indicated in parentheses of { }.

Explanation of terms for maintenance standard (ALL-0330-006-A-01-A)

(Rev. 2012/10)

- " The chapter of maintenance standard shows judgement criteria to determine the products to be replaced or to be reused. The judgement criteria are described by using the following terms.

Standard dimension and tolerance

- " To be accurate, the finished dimension of a part is slightly different from one to another.
- " The finished dimension of a part specifies the allowable difference from the standard dimension which is set first.
- " The dimension set as the standard is called the standard dimension and the range of difference from this standard dimension is called the "tolerance".
- " An indication example of a standard dimension and tolerance is shown in the following table. (The standard dimension is entered on the left side and the tolerance is entered with a positive or negative symbol on the right side)

Example:

Standard dimension	Tolerance
120	-0.022
	-0.126

- " The tolerance may be indicated in the text and a table as "standard dimension (upper limit of tolerance/lower limit of tolerance)."
Example: 120(-0.022/-0.126)
- " Usually, the dimension of a hole and the dimension of a shaft to be inserted into the hole are indicated by the same standard dimension and different tolerances of the hole and shaft. The tightness of fit is decided by the tolerance.
- " An indication example of a shaft and hole is shown in the following table.
(The standard dimension is entered on the left side and the tolerance of the shaft is entered with a positive or negative symbol at the center and that of the hole on the right side)

Standard dimension	Tolerance	
	Shaft	Hole
60	-0.030	+0.046
	-0.076	0

Standard clearance and standard value

- " The clearance made when new parts are assembled is called the standard clearance, which is indicated by the range from the minimum clearance to the maximum clearance.
- " When some parts are repaired, the clearance is generally adjusted to the standard clearance.
- " The values indicating performance and function of new products or equivalent are called the "standard value", which is indicated by a range or a target value.

- " When some parts are repaired, the value of performance/function is set to the standard value.

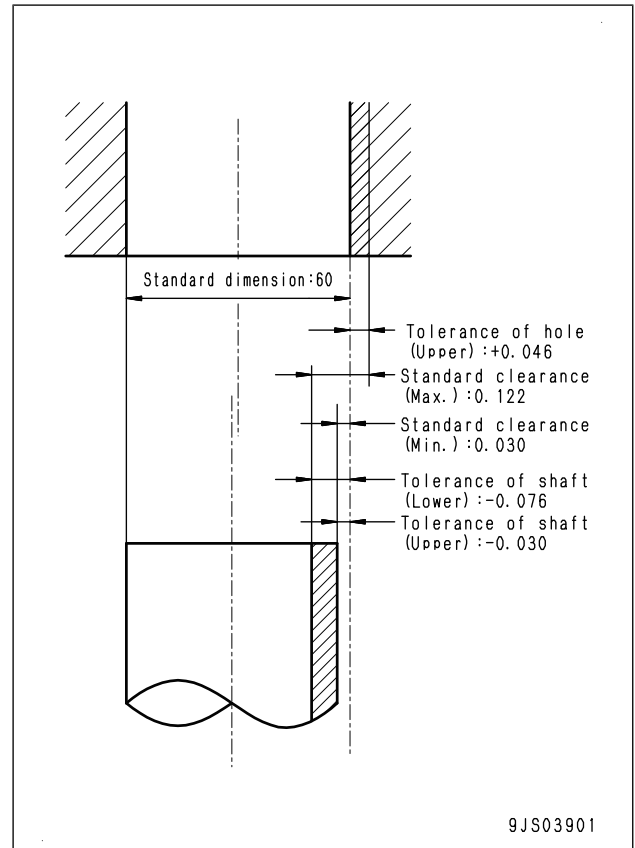

Standard interference

- " When the diameter of a hole of a part shown in the given standard dimension and tolerance table is smaller than that of the shaft to be inserted, the difference between those diameters is called the "interference".
- " Subtract the maximum dimension of the hole from the minimum dimension of the shaft and call it (A). Subtract the minimum dimension of the hole from the maximum dimension of the shaft and call it (B). The range between (A) and (B) is the "standard interference".
- " After repairing or replacing some parts, measure the dimension of their hole and shaft and check that the interference is in the standard range.

Repair limit and allowable value or allowable dimension

- " The dimensions of parts change because of the wear or deformation while they are used. When the dimension changes exceeding certain value,

00 Index and foreword

Foreword, safety and general information

the parts can not be used any longer. This value is called "repair limit".

- " If a part is worn to the repair limit, it must be replaced or repaired.
- " The performance and function of the products lower while they are used. When the value of the performance and function lowers exceeding a certain limit and it influences the operation etc., this value is called the allowable value or allowable dimension.
- " A product whose dimension is out of the allowable value, must be repaired. However, since the allowable values are generally estimated through various tests or experiences in most cases, the judgement must be made in consideration of the operating condition and customer's requirement.

Allowable clearance

- " Parts can be used until the clearance between them is increased to a certain limit. The limit at which those parts cannot be used is called the "allowable clearance".
- " If the clearance between the parts exceeds the allowable clearance, they must be replaced or repaired.

Allowable interference

- " The allowable maximum interference between the hole of a part and the shaft of another part to be assembled is called the "allowable interference".
- " The allowable interference shows the repair limit of the part of smaller tolerance.
- " The parts whose interferences are out of the allowable interference must be replaced or repaired.

Handling equipment of fuel system devices (PC-AD00-2A4-K-00-A)

(Rev. 2012/01)

- " The common rail fuel injection system (CRI) consists of more precise parts than the parts used in the conventional fuel injection pump and nozzle. If foreign material enters this system, it may cause a failure. Use special care to prevent entry of the foreign material when servicing the fuel system.

Use care for working environment

- " Avoid filter change or repairing the machine in rain or high winds, or at places where there is a lot of dust.

Sealing openings

- " Plug the pipes and the openings of the components which are removed with the caps, tapes, vinyl bags, etc. to prevent foreign material from entering. Never perform repair works under the condition that the openings are left as they are or plugged with cloths as foreign material may enter or environment may be polluted by the oil leaked. Do not discard the waste oil somewhere or other. Hand it over to your customer for disposal, or dispose it by yourself.

How to clean parts when dirt is stuck

- " If any dirt or dust sticks the parts of the fuel system, clean it off thoroughly with clean fuel.

Precautions for replacing fuel filter cartridge

- " Be sure to use the Komatsu genuine fuel filter cartridge.
- " The common rail fuel injection system (CRI) consists of more precise parts than the parts used in the conventional fuel injection pump and nozzle. In order to prevent foreign material from entering this system, the filter employs a specially high performance of filter element. If a filter element other than the genuine one is used, the fuel system may have a failure. Accordingly, never use such a filter element.

Handling of intake system parts (PC220-A900-2A4-K-00-A)

(Rev.2013/10)

- " The Komatsu Variable Geometry Turbocharger consists of more precise parts (variable mechanism) than the parts used in the conventional turbocharger. If foreign material enters this system, it may cause a failure. Use special care to prevent entry of the foreign material when servicing the air intake system.

Be careful of working environment

- " Avoid the repair work of the machine in rain or strong wind or at the places where there is a lot of dust.

Sealing openings

- " Plug the pipes and the openings of the components which are removed, with the caps, tapes, vinyl bags, etc. to prevent foreign material from entering. Never perform repair works under the condition that the openings are left open or plugged with rag since foreign material may enter.

Handling of hydraulic equipment (ALL-C000-2A4-P-01-A)

(Rev. 2012/10)

- " With the increase in pressure and precision of the hydraulic components, the most common cause of a failure is dirt (foreign material) in the hydraulic circuit. Therefore, the special care must be taken when adding hydraulic oil, or when disassembling or assembling the hydraulic components.

Be careful of working environment

- " Avoid adding hydraulic oil, replacing filters, or repairing the machine in rain or high winds, or at places where there is a lot of dust.

Disassembly and maintenance work in the field

- " When disassembly or maintenance work of the hydraulic is performed in the field, there is danger of dust entering the components. It is also difficult to check the performance of the components after repairs, so it is desirable to use the component exchange service. The disassembly and assembly of the hydraulic components must be performed in the specially arranged dustproof workshop and the performance test of the components must be performed with the special testing equipment.

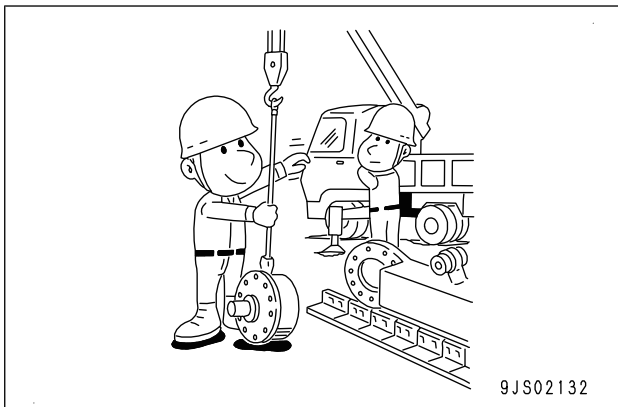

Plugging of opening (prevention of flowing out of oil)

- " Plug the pipes and the openings of the components which are removed (when plugs are not prepared, seal with caps, tapes, vinyl bags, etc.) to prevent entry of foreign material and flowing out of oil. Never leave the openings of the pipes and hoses without being covered or plugged with cloth as foreign material may enter them or environment may be polluted by the oil leaked. Do not discard the waste oil somewhere or other. Hand it over to your customer for disposal, or dispose it by yourself.

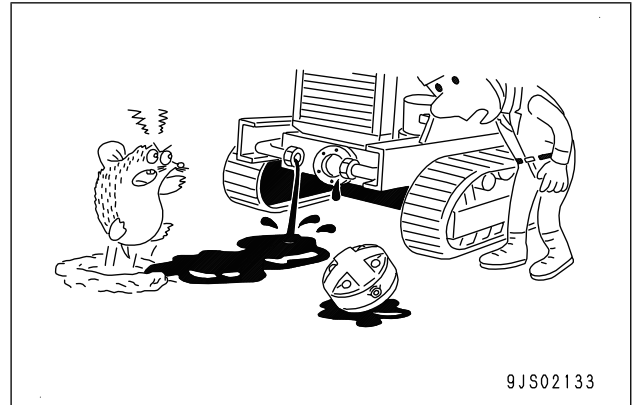

Preventing intrusion of foreign materials during refilling operations.

- " Care must be taken when adding hydraulic oil so that foreign material does not enter. Keep the oil filler port and the area around it, oil supply pump and oil container clean. If an oil cleaning device is used, it is possible to remove the dirt that is collected during storage. It is a surer means.

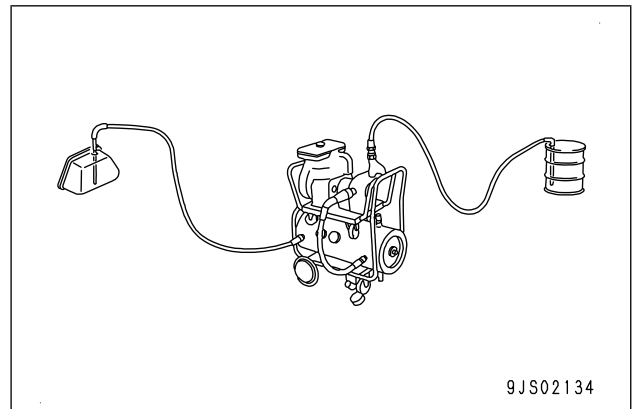

Replacing hydraulic oil while its temperature is high

- " When the hydraulic oil is warm, it flows easily. In addition, sludge can also be drained from the circuit together with the oil. So, it is better to change the hydraulic oil while it is warm. When changing the hydraulic oil, the old oil must be drained as much as possible. (Drain the oil not only from the hydraulic tank, but also from the filter housing and the drain plug hole in the circuit.) If the old oil is left in the system, the contaminant and sludge in the oil mix with the new oil and shorten the life of the new hydraulic oil.

00 Index and foreword

Foreword, safety and general information

Flushing operations

- " After disassembling the equipment or when changing the hydraulic oil with new one, flush the system to remove the contaminant and sludge left in the hydraulic circuit as well as the oil which includes them. Normally, flushing is performed twice. Primary flushing is performed by use of the flushing oil and the secondary flushing is performed by use of the specified hydraulic oil.

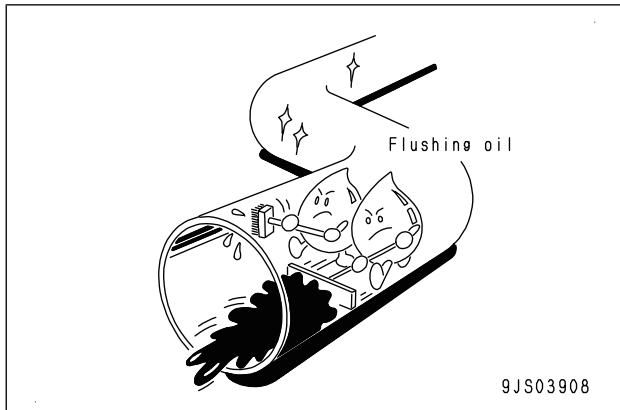

Cleaning operations

- " After repairing the hydraulic equipment (pump, control valve, etc.) or when the machine is in operation, perform oil cleaning to remove the sludge or contaminant in the hydraulic oil circuit. The oil cleaning equipment can remove the ultra fine (approximately 3 μm) particles that the filter built in the hydraulic equipment can not remove. So, it is an extremely effective device.

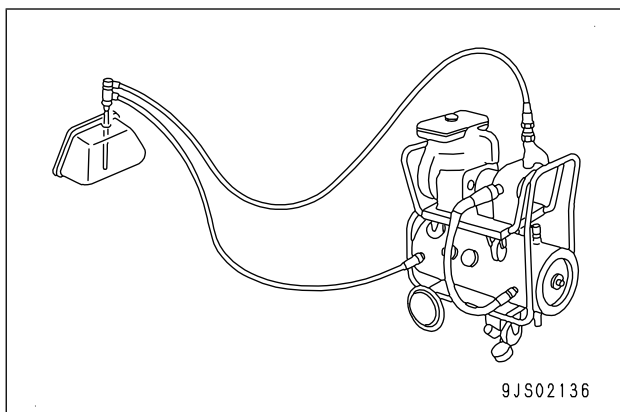

Method of disconnecting and connecting of push-pull type coupler (ALL-

C930-001-P-00-A)

(Rev. 2012/01)

⚠ Loosen the oil filler cap of the hydraulic tank slowly to release the remaining pressure in the hydraulic tank.

⚠ Even if the remaining pressure is released from the hydraulic tank, some hydraulic oil flows out when the hose is disconnected. Accordingly, prepare an oil container.

Type 1 (ALL-C930-925-P-01-A)

Disconnection

1. Hold adapter (1) and push hose joint (2) into mating adapter (3). (Fig. 1)
 - ★ It can be pushed in by approximately 3.5mm.
 - ★ Do not hold rubber cap portion (4).
2. While pushing hose joint (2) into adapter (3), push rubber cap (4) against adapter (3) until "click" is heard. (Fig. 2)
3. Hold hose adapter (1) or hose (5) and pull it out. (Fig. 3)
 - ★ Since some hydraulic oil flows out, prepare an oil container.

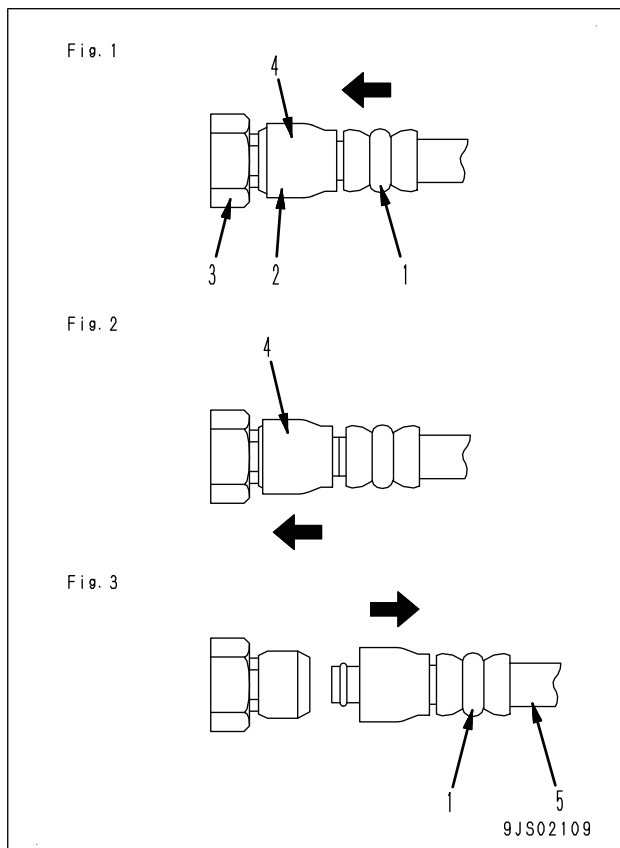

Connection

1. Hold hose adapter (1) or hose (5) and insert it in mating adapter (3) aligning them with each other. (Fig. 4)
 - ★ Do not hold rubber cap part (4).
2. After inserting the hose fitting in the adapter on the other side perfectly, pull it back to check the connecting condition. (Fig. 5)
 - ★ When the hose fitting is pulled back, the rubber cap will move approximately 3.5mm toward the hose, however, it is not a problem.

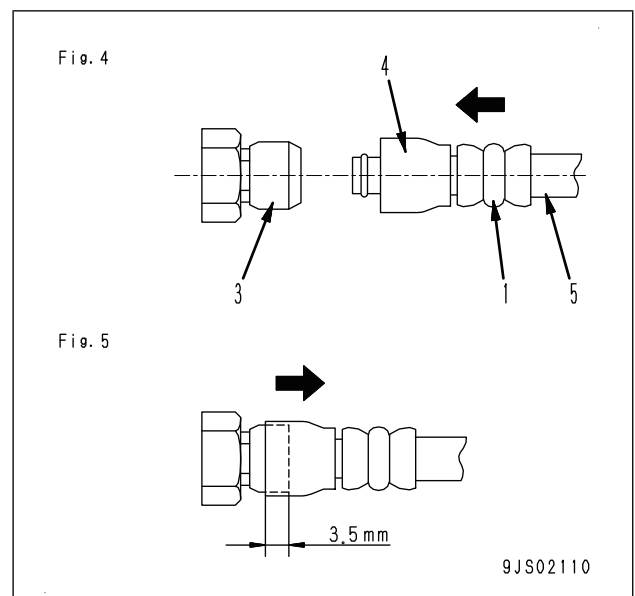

Type 2 (ALL-C930-925-P-02-A)

Disconnection

1. While holding the fitting, push body (7) in straight until sliding prevention ring (6) hits contact surface (a) at the hexagonal part on the male side. (Fig. 6)
2. While keeping the condition of Step 1, turn lever (8) to the right (clockwise). (Fig. 7)
3. While keeping the conditions of Steps 1 and 2, pull out whole body (7) to disconnect it. (Fig. 8)

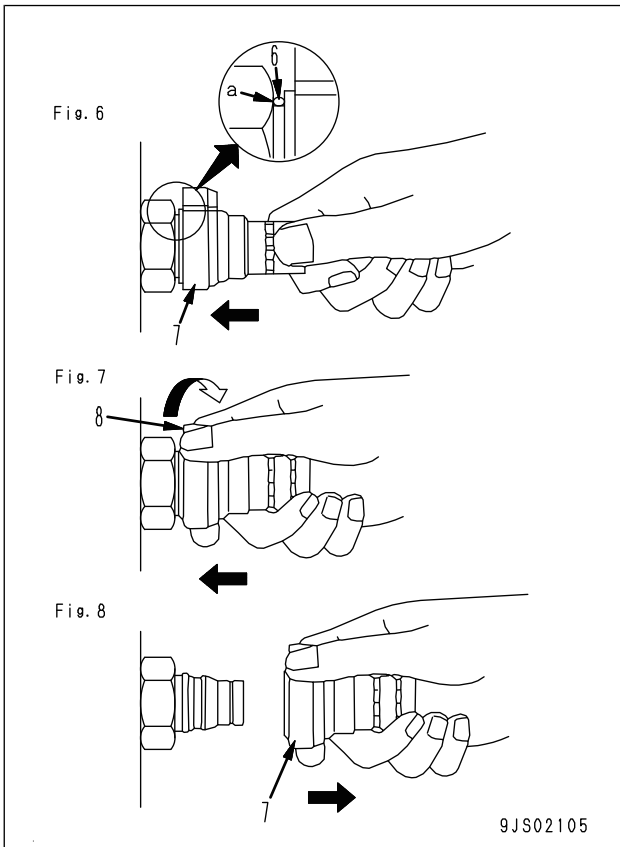

Connection

1. While holding the fitting, push body (7) in straight until sliding prevention ring (6) hits contact surface (a) at the hexagonal part on the male side to connect it. (Fig. 9)

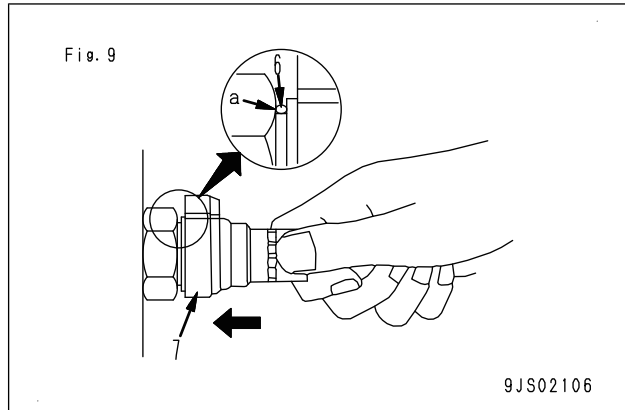

Type 3 (ALL-C930-925-P-03-A)

Disconnection

1. While holding the fitting, push body (9) in straight until sliding prevention ring (8) hits contact surface (b) at the hexagonal portion on the male side. (Fig. 10)
2. While keeping the condition of Step 1, push cover (10) straight until it hits contact surface (b) of the hexagonal portion on the male side. (Fig. 11)
3. While keeping the conditions of Steps 1 and 2, pull out whole body (9) to disconnect it. (Fig. 12)

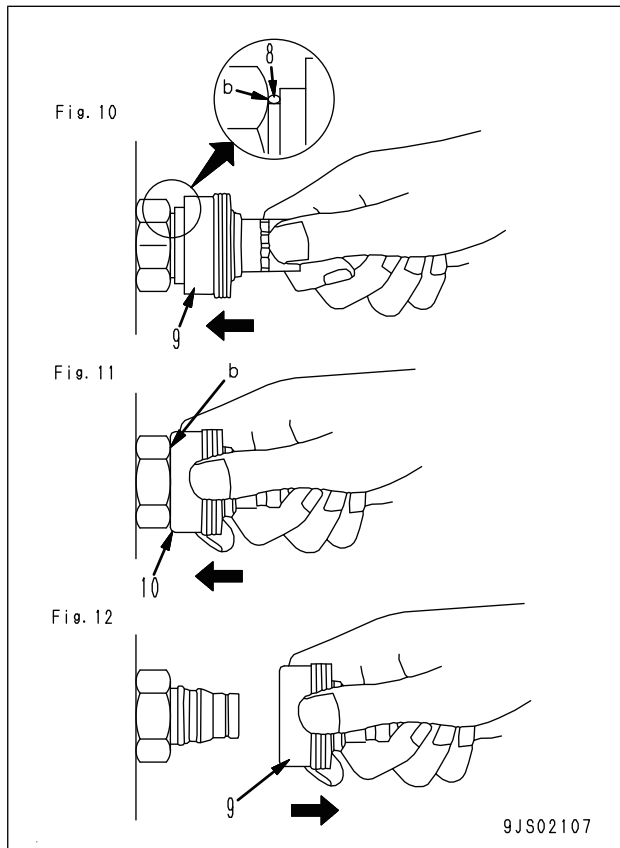

Connection

1. While holding the fitting, push body (9) in straight until sliding prevention ring (8) hits contact surface (a) at the hexagonal portion on the male side to connect them. (Fig. 13)

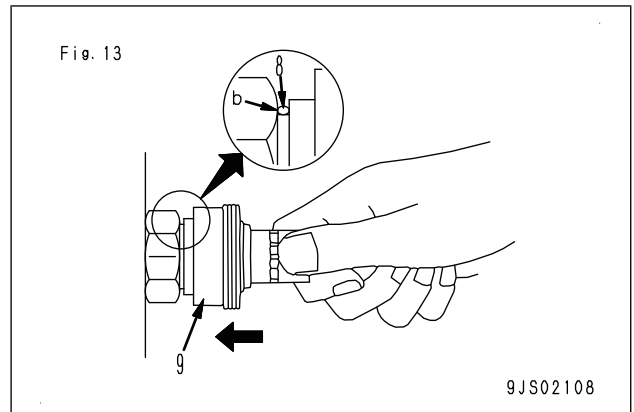

Handling of electrical equipment (ALL-E000-2A4-P-01-A)

(Rev. 2012/11)

- " To maintain the performance of the machine over a long period, and to prevent failures or troubles before they occur, correct "operation", "maintenance and inspection" "troubleshooting", and "repairs" must be performed. This section deals particularly with correct repair procedures for mechatronics components and is aimed at improving the quality of repairs. For this purpose, it describes the working procedures in "Handling of electrical equipment".

Precautions for handling electric equipment

Handling wiring harnesses and connectors

- " Wiring harnesses consist of wires connecting one component to another component, connectors used for connecting and disconnecting one wire from another wire, and protectors or tubes used for protecting the wires.
- " Compared with other electrical components fitted in boxes or cases, wiring harnesses are more likely to be affected by the direct effects of rain water, heat, or vibration. Furthermore, during inspection and repair operations, they are frequently removed and installed again, so they are likely to suffer deformation or damage. For this reason, it is necessary to be extremely careful when handling the wiring harnesses.

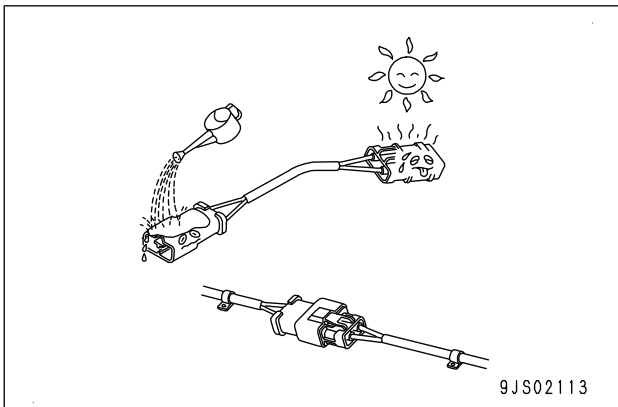

Main failures occurring in wiring harness

Defective contact of connectors (defective contact between male and female connectors)

- " Problems with defective contact are likely to occur because the male connector is not properly inserted into the female connector, or because one or both of connectors are deformed or the position is not correctly aligned, or because there is corrosion or oxidization of the contact surfaces. The corroded or oxidized contact surfaces may become shiny again (and contact may become normal) by connecting and disconnecting the connectors approximately 10 times.

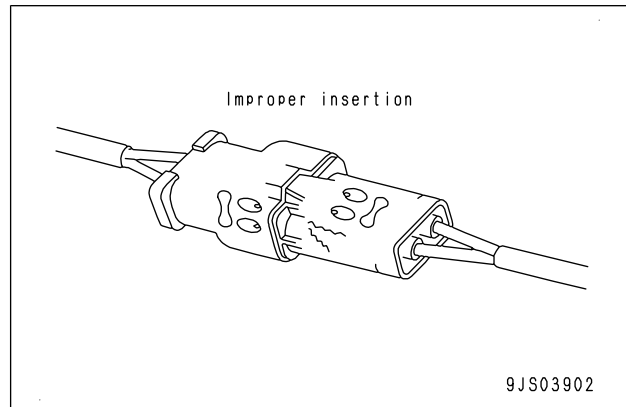

Defective crimping or soldering of connectors

- " The pins of the male and female connectors are attached to wires by crimping or soldering. If excessive force is applied to the wire, the joining area may become loose, which may result in a defective connection or breakage.

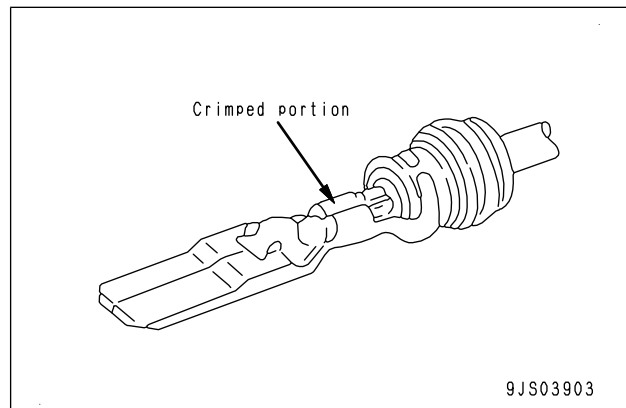

Disconnections in wiring

- " If the wiring harness is pulled to disconnect the connector, or the components are lifted with a crane while the wiring harness is still connected, or a heavy object hits the wiring harness, the crimping of the connector may separate, or the soldering may be damaged, or the wiring harness may be broken.

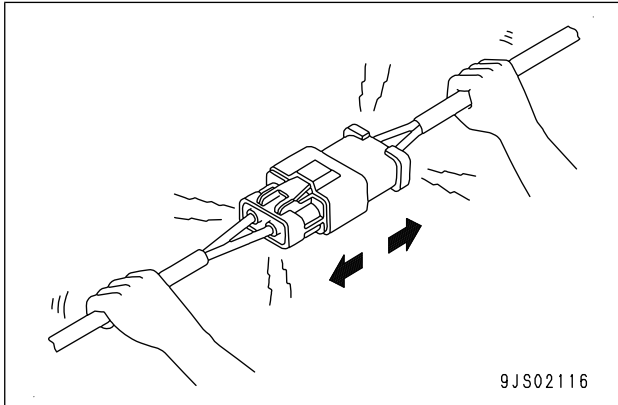

High-pressure water entering connector

" The connector is designed to make it difficult for water to enter (drip-proof structure), but if high-pressure water is sprayed directly on the connector, water may enter the connector, depending on the direction of the water jet. Accordingly, take care not to spray water over the connector.

The connector is designed to prevent water from entering, but once water does enter, it is difficult to drain it. If water should get into the connector, the pins will be short-circuited by the water. So if any water gets in, immediately dry the connector or take other appropriate action before passing electricity through it.

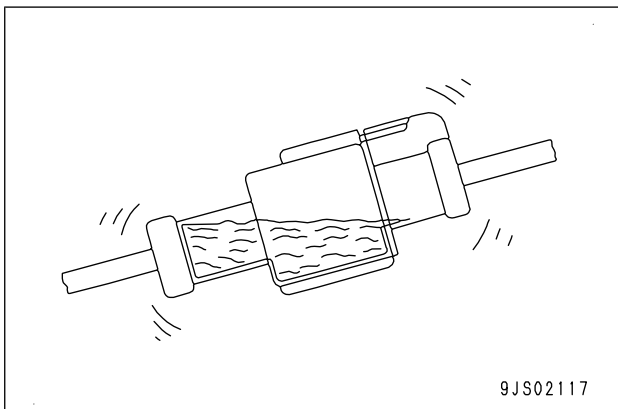

Entry of water, mud or dirt when disconnecting a connector

" If any water, mud or dirt is stuck to the outside surface of a connector, it can enter inside the connector when the connector is disconnected. Before disconnecting the connector, wipe off any stuck water or dirt by using a piece of dry cloth or blow it with compressed air.

Oil, mud or dirt stuck to connector

" If any oil or grease is stuck to the connector and an oil film is formed on the mating surface of the male and female pins, the oil prevents electricity from passing through, resulting in defective contact. If any oil or grease, mud or dirt is stuck to the connector, wipe it off with a dry cloth or

blow it with compressed air and spray it with electrical contact restorer.

- ★ When wiping the joint portion of the connector, be careful not to apply excessive force or deform the pins.
- ★ If there is oil or water in the compressed air, it causes the contacts to become dirtier. So, remove the oil and water from the compressed air completely before cleaning the connector with the compressed air.

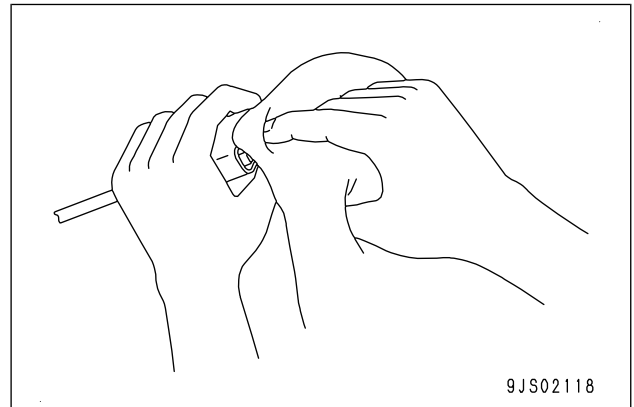

Removing, installing, and drying connectors and wiring harnesses

Disconnecting connectors

1. Hold the connectors when disconnecting.

" Disconnect connectors by holding the connector bodies. For the connectors held by a screw, loosen the screw fully, then hold the male and female connectors with each hand respectively and pull them apart horizontally. For the connectors with lock stopper, press down the stopper with your thumb and pull the connectors apart.

- ★ Never pull the connector with one hand.

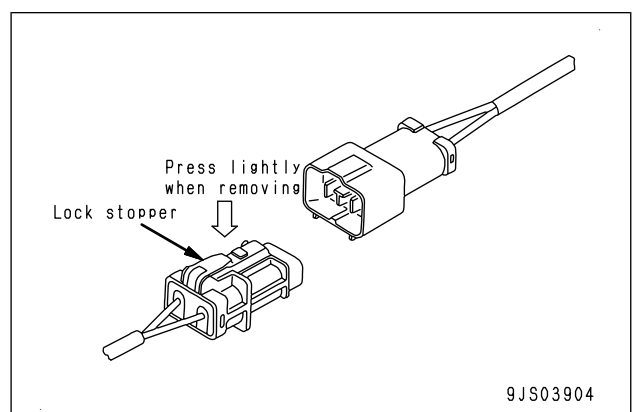

2. When removing from clips

" Both of the connector and clip have stoppers, which are engaged with each other when the connector is connected.

00 Index and foreword

Foreword, safety and general information

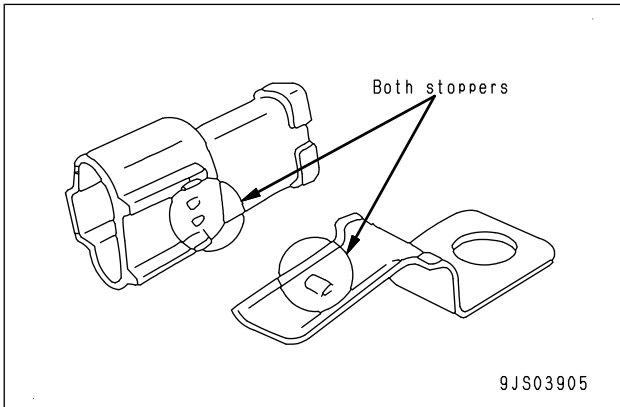

- " When removing a connector from a clip, pull the connector in a parallel direction to the clip for removing stoppers.
- ★ If the connector is pried up and down or to the right and left, the housing may break.

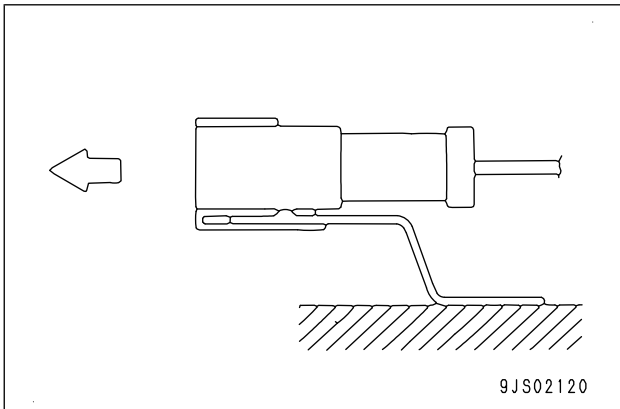

3. Action to take after removing connectors

- " After removing the connector, cover it with the vinyl bag to prevent entry of dust, dirt, oil or water in the contact portion.
- ★ If the machine is left disassembled for a long time, it is particularly easy for improper contact to occur, so always cover the connector.

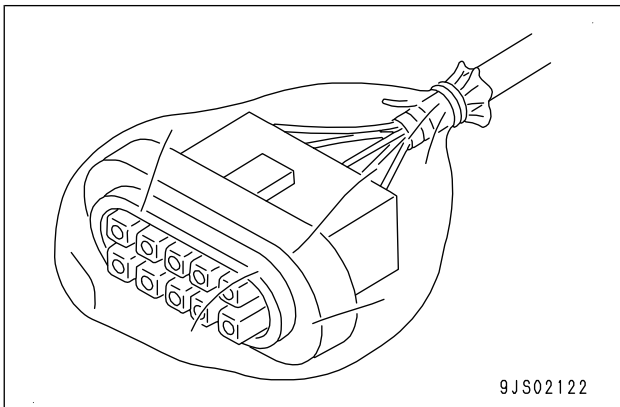

Connecting connectors

1. Check the connector visually.

- " Check that there is no oil, dirt or water stick to the connector pins (joint portion).
- " Check that the connector pins are free from deformation, defective contact, corrosion, or damage.
- " Check that external surfaces of the connectors are free from damage or breakage.

- ★ If any oil, water or dirt is stuck to the connector, wipe it off with a dry cloth. If any water is inside the connector, warm the connector and the inside of the wiring harness with a dryer. But be careful not to make it too hot as it causes short circuit.

- ★ If there is any damage or breakage, replace the connector.

2. Fix the connector securely.

- " Align the connectors correctly, and fit them securely. For the connectors with the lock stopper, push in the connectors until "click" is heard.

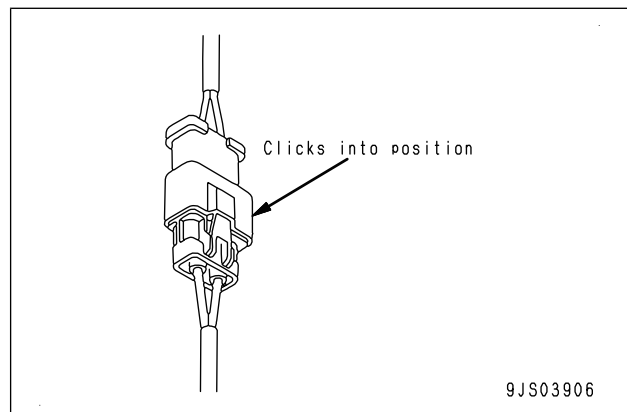

3. Correct the protrusion of the boot and misalignment of the wiring harness

- " For connectors fitted with the boot, correct any extrusion of the boot. In addition, if the wiring harness or the clamp is out of the position, put it in its original position.

- ★ If the connector cannot be corrected easily, remove the clamp and adjust the position.

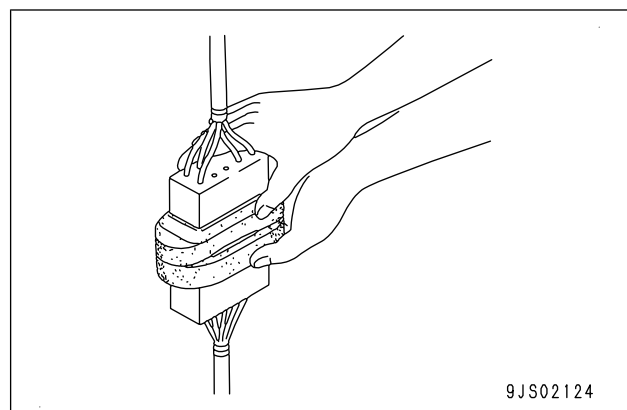

- If the connector clamp is removed, be sure to return it to its original position. And check that it is securely installed.

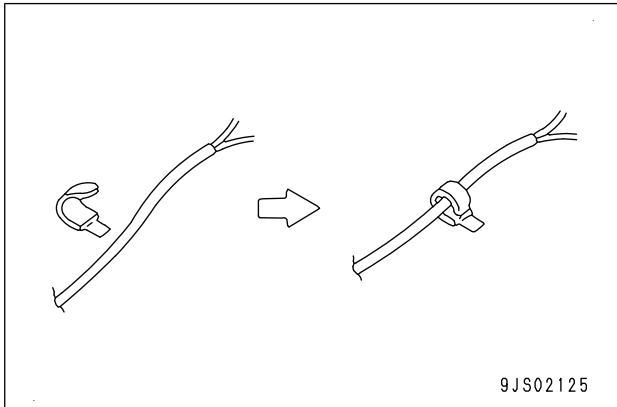

Handling of Deutsch connector (DT8-pin, DT12-pin)

Disconnection

1. While pressing locks (a) and (b) from each side respectively, pull out female connector (2).

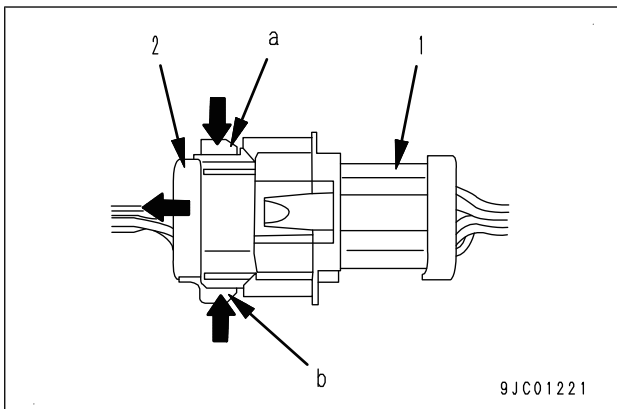

Connection

1. Push in female connector (2) horizontally until the lock clicks. (Arrow: x)
 2. Since locks (a) and (b) may not be set completely, push in female connector (2) with curving movement until the locks are set normally. (Arrow: x, y, and z)
- ★ Lock (a) in the figure is pulled down (not set completely), and lock (b) is set completely.

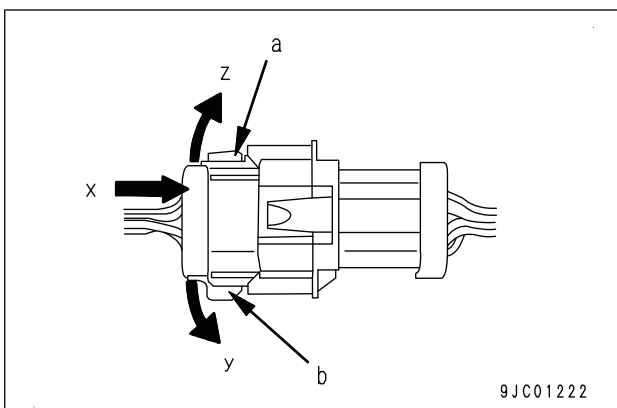

Drying wiring harness

- If there is any oil or dirt on the wiring harness, wipe it off with a dry cloth. Avoid washing by using steam. If the wire harness must be washed in water, do not apply high pressure water or steam directly to the wiring harness. If water gets directly on the connector, do as follows.
1. Disconnect the connector and wipe off the water with a dry cloth.
 - ★ If the connector is to be blown with dry compressed air, there is a risk that oil in the air may cause defective contact of the conditioner, remove oil and water in the air before starting air blow.

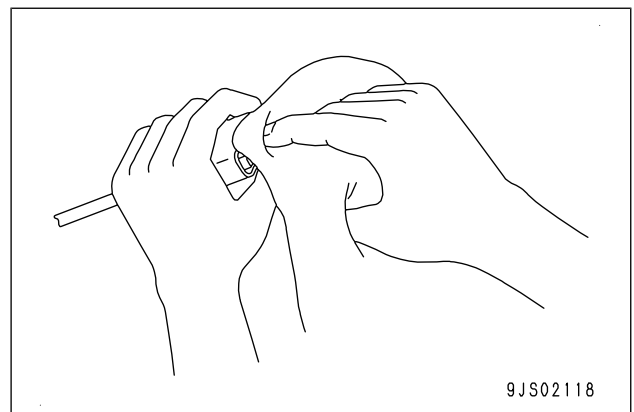

2. Dry the inside of the connector with a dryer. If water gets inside the connector, use a dryer to dry the connector.
 - ★ Hot air from the dryer can be used, but regulate the time to use hot air in order to prevent the connector or related parts from becoming too hot, as it causes deformation or damage to the connector.

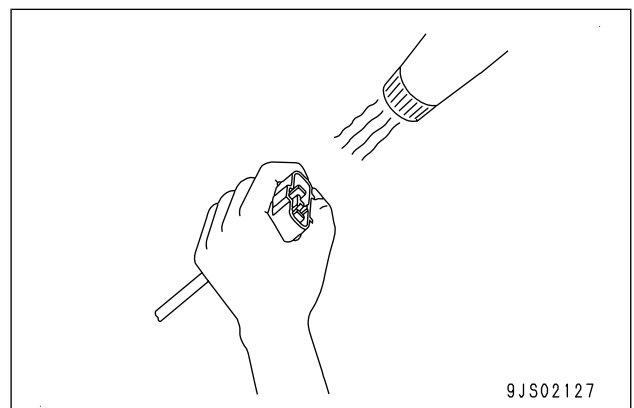

3. Perform a continuity test on the connector. After drying, leave the wiring harness disconnected and perform a continuity test to check for any short circuits between pins caused by water.
 - ★ After the connector is completely dried, blow the contact restorer and reassemble them.

00 Index and foreword

Foreword, safety and general information

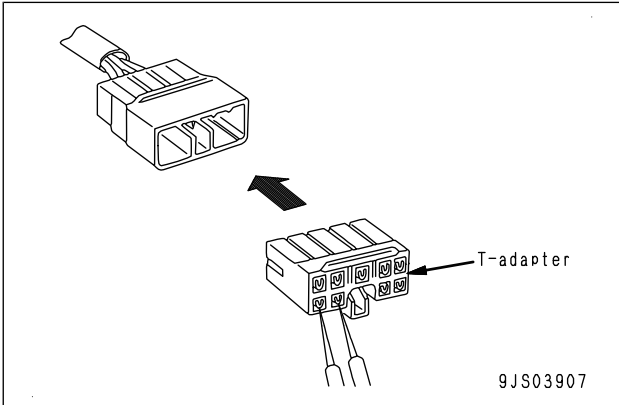

Handling of connectors used on engine

Slide, lock type (FRAMATOME-3, FRAMATOME-2)

Disconnection

1. Slide lock (L1) to the right.
2. While pressing lock (L2), pull out connector (1) toward you.

- ★ In the case that even if lock (L2) is pressed, connector (1) cannot be pulled out toward you unless part A floats, float part A with a small flat-head screwdriver while pressing lock (L2), and then pull out connector (1) toward you.

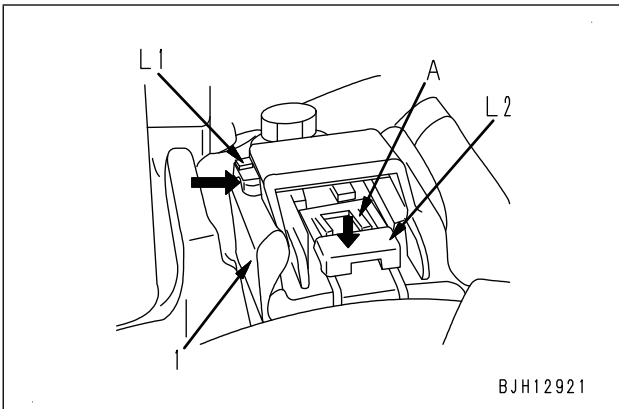

Connection

1. Insert the connector securely until a click is heard.

(FRAMATOME-24)

Disconnection

1. Slide down lock (red) (L1).

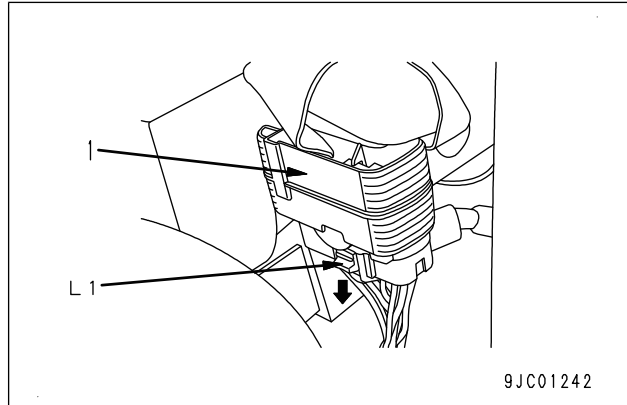

2. While pressing lock (L2), pull out connector (1).

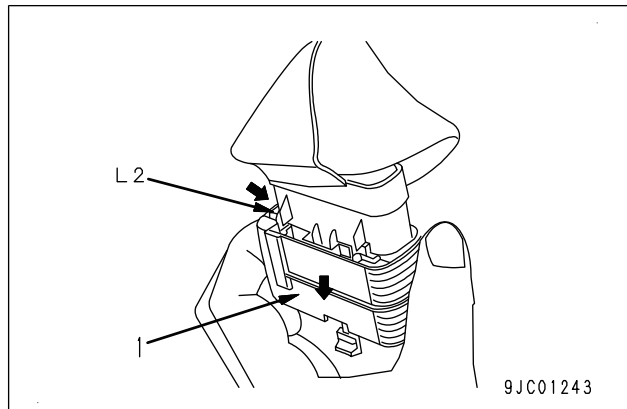

- ★ Lock (L2) is located in the back of connector (1).

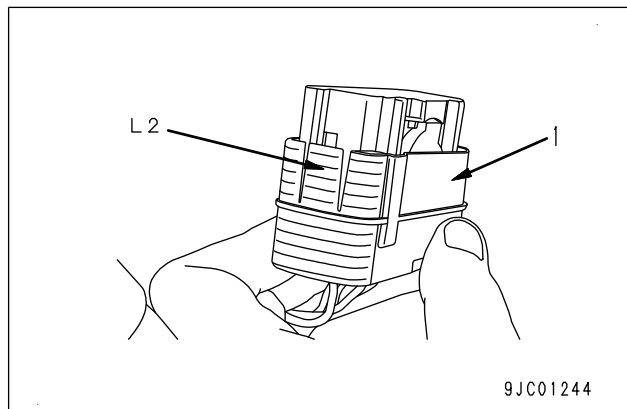

Connection

1. Insert the connector securely until a click is heard.

Pull lock type (PACKARD-2)

Disconnection

1. Disconnect the connector (2) by pulling lock (B) (on the wiring harness side) of connector (2) outward.

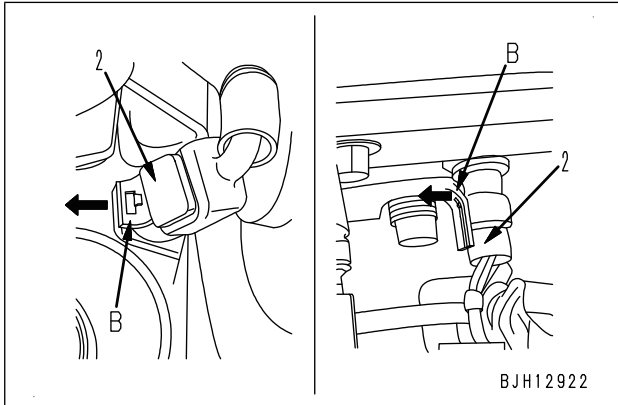

Connection

1. Insert the connector securely until a click is heard.

**Push lock type
(BOSCH-3)**

Disconnection

1. While pressing lock (C), pull out connector (3) in the direction of the arrow.
" 114 series

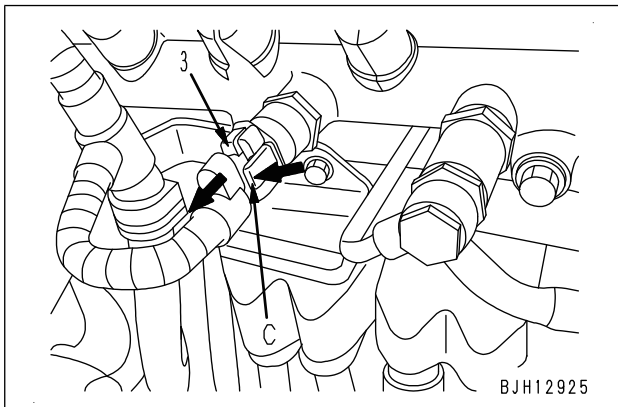

" 107 series

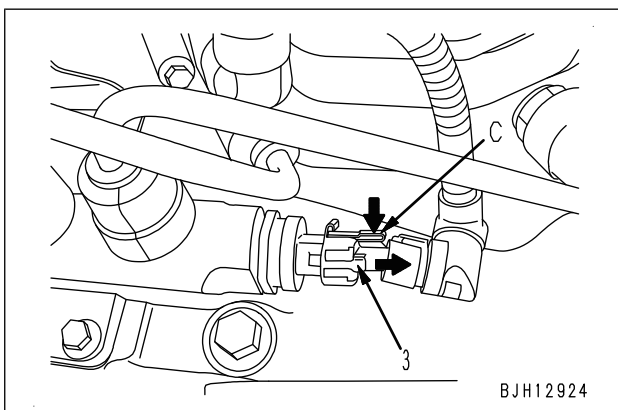

- ★ If the lock is located on the underside, use flat-head screwdriver [1] since you cannot insert your fingers.

While pushing up lock (C) of the connector with flat-head screwdriver [1], pull out connector (3) in the direction of the arrow.

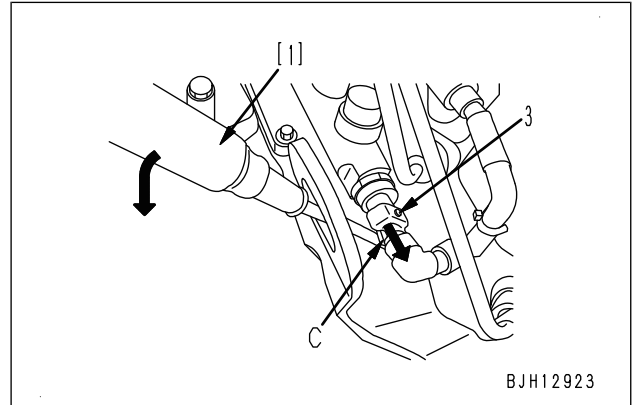

Connection

1. Insert the connector securely until a click is heard.

(AMP-3)

Disconnection

1. While pressing lock (E), pull out connector (5) in the direction of the arrow.

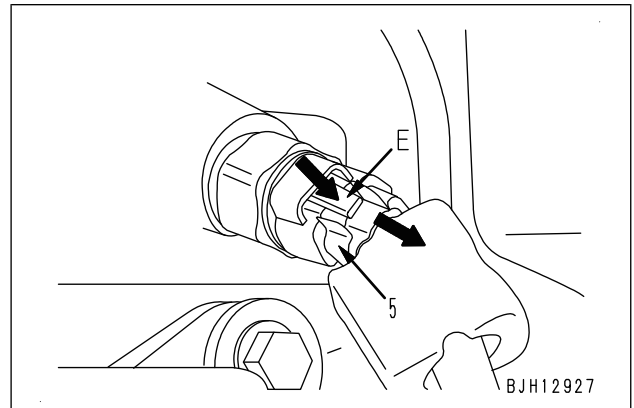

Connection

1. Insert the connector securely until a click is heard.

(SUMITOMO-2)

Disconnection

1. While pressing lock (E), pull out connector (5) in the direction of the arrow.

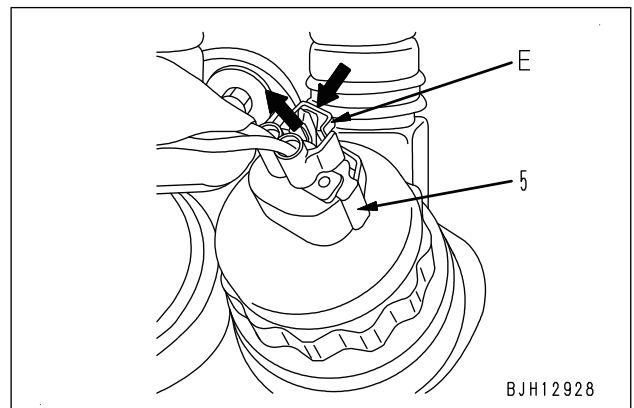

Connection

1. Insert the connector securely until a click is heard.

00 Index and foreword

Foreword, safety and general information

(SUMITOMO-3)

Disconnection

1. While pressing lock (E), pull out connector (5) in the direction of the arrow.

★ Pull the connector straight up.

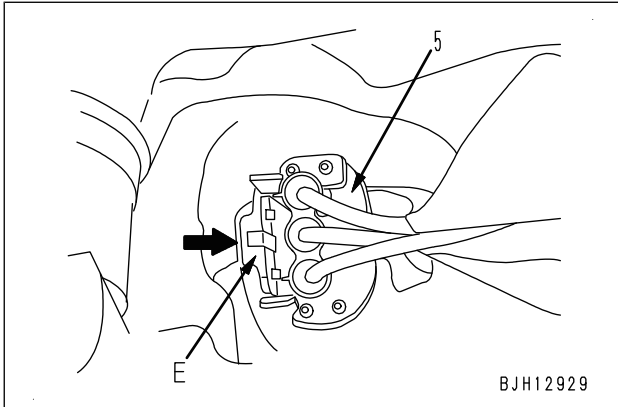

Connection

1. Insert the connector securely until a click is heard.

(SUMITOMO-4)

Disconnection

1. While pressing lock (D), pull out connector (4) in the direction of the arrow.

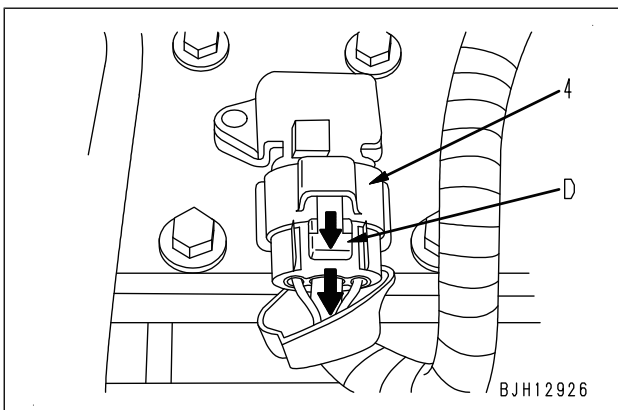

Connection

1. Insert the connector securely until a click is heard.

Turn-housing type (Round green connector) (CANNON-4)

Disconnection

1. Turn housing (H1) in the direction of the arrow.
 - ★ Unlock the connector by turning housing (H1). When the lock is released, the housing is felt tight to turn.
2. Pull out housing (H1) in the direction of the arrow.

★ Housing (H1) is left on the wiring harness side.

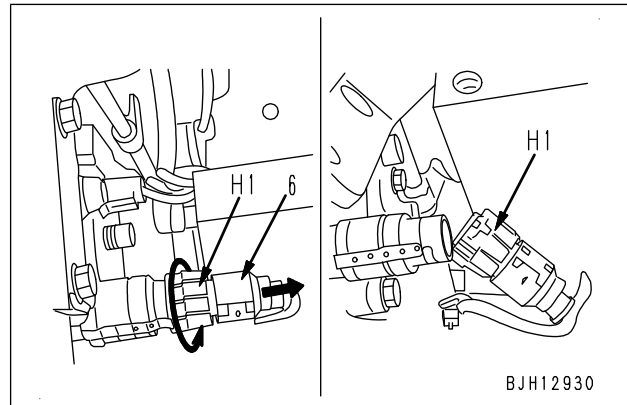

Connection

1. Insert the connector to the end while aligning its groove to the other.
2. Turn housing (H1) in the direction of the arrow until it "clicks".

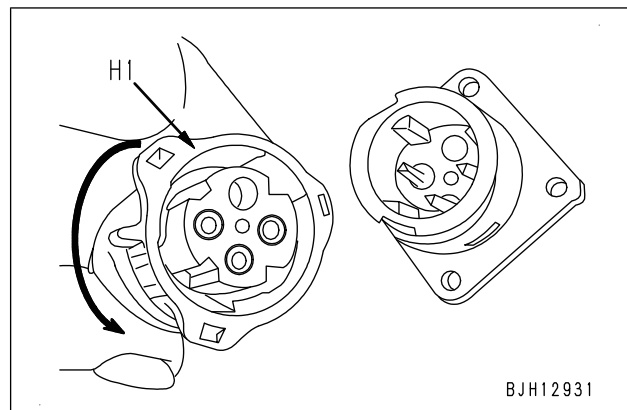

Handling controller

- " The electronic circuits for control including the microcomputers are assembled in the controller. These electronic circuits in the controller must be handled with care as they control the machine.
- " Do not place objects on top of the controller.

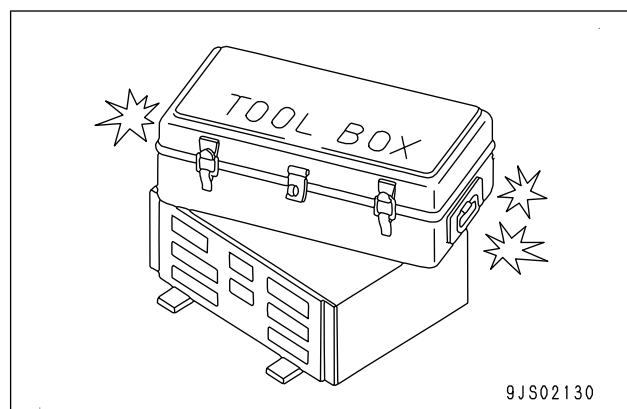

- " Cover the control connectors with tape or a vinyl bag. Never touch the connector contacts.
- " During rainy weather, do not leave the controller in a place where it is exposed to rain.
- " Do not place the controller on oil, water, or soil, or in a place that can be heated to a high

temperature even for a short period of time.
(Place it on a suitable dry stand.)

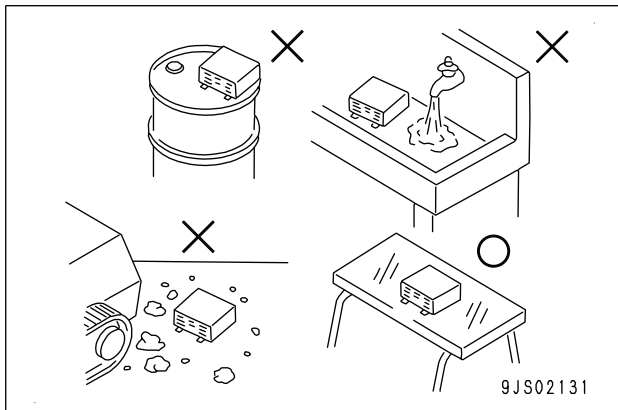

- " Precautions when performing arc welding
When performing arc welding on the machine body, disconnect all the wiring harness connectors connected to the controller. Put the arc welding ground to the place close to the welding point.

Precautions for troubleshooting electrical circuits

- " Be sure to turn the starting switch to "OFF" position before disconnecting or connecting the connectors.
- " Before performing troubleshooting, check all the related connectors for loose connection.
 - ★ Check the related connectors for their performance by disconnecting and connecting them several times.
- " Be sure to connect all the disconnected connectors before proceeding to the next step.
 - ★ If the starting switch is turned to "ON" position with the connectors disconnected, the failure which is not related to the part which is actually failed.
- " When performing the troubleshooting for the circuit (measurement of voltage, resistance, continuity, current, etc.), shake the related wiring harnesses and connectors several times and check that the multimeter reading does not change.
 - ★ If there is any value change on the multimeter, there may be a defective contact in the circuit.

00 Index and foreword

Foreword, safety and general information

How to read electric wire code (ALL-E500-030-P-00-A)

(Rev. 2012/10)

" In the electrical circuit diagram, material, thickness and color of each electric wire are indicated by symbols. The wire code is helpful in understanding the electrical circuit diagram.

Example) AEX 0.85 L: Indicates blue, heat-resistant, low-voltage wire for automobile, having nominal No. of 0.85

AEX	Indicates type of wire by symbol. Type, symbol, and material of wire are shown in Table 1. (Since the use of AV and AVS wires depends on size (nominal No.), their symbols are not indicated on the diagram.)
0.85	Indicates size of wire by nominal No. Size (Nominal No.) is shown in Table 2.
L	Indicates color of wire by color code. Color codes are shown in Table 3.

Type, symbol, and material

" AV and AVS are different in thickness and outside diameter of the coating. CAVC has a circular compressed conductor. It differs from AV and AVS in the outside diameter of conductor and thickness of the coating. And AEX is similar to AV in thickness and outside diameter of the coating but different from AV and AVS in material of the coating.

(Table 1)

Type	Sym- bol	Conductor material	Insulator material	Temperature range (°C) in use	Example of use
Low-voltage wire for automobile	AV	Annealed copper for electric appliance	Soft polyvinyl chloride	-30 to +60	For large current wiring (nominal No. 5 and above)
Thin-cover low-voltage wire for automobile (Type 1)	AVS				General wiring (nominal No. 3 and lower)
Thin-cover low-voltage wire for automobile (Type 2)	CAVS				For mid- to small-size excavators (nominal No. 1.25 and lower)
Heat- resistant low- voltage wire for automobile	AEX		Heat-resistant cross linked polyethylene	-50 to +110	General wiring for extremely cold weather specification Wiring at high ambient temperature place

Dimensions
(Table 2)

Nominal No.		0.5f	(0.5)	0.75f	(0.85)	1.25f	(1.25)	2f	2	3f	3	5
Conductor	Number of strands/ Diameter of strand	20/ 0.18	7/0.32	30/ 0.18	11/ 0.32	50/ 0.18	16/ 0.32	37/ 0.26	26/ 0.32	58/ 0.26	41/ 0.32	65/ 0.32
	Cross-sectional area (mm ²)	0.51	0.56	0.76	0.88	1.27	1.29	1.96	2.09	3.08	3.30	5.23
	d (approx.)	1.0		1.2		1.5		1.9	1.9	2.3	2.4	3.0
Coating D	AVS	Standard	2.0	2.2		2.5		2.9	2.9	3.5	3.6	—
	AV	Standard	—	—		—		—	—	—	—	4.6
	AEX	Standard	2.0	2.2		2.7		3.0	3.1	—	3.8	4.6
Nominal No.		8	15	20	30	40	50	60	85	100		
Conductor	Number of strands/ Diameter of strand	50/0.45	84/0.45	41/0.80	70/0.80	85/0.80	108/ 0.80	127/ 0.80	169/ 0.80	217/ 0.80		
	Cross-sectional area (mm ²)	7.95	13.36	20.61	35.19	42.73	54.29	63.84	84.96	109.1		
	d (approx.)	3.7	4.8	6.0	8.0	8.6	9.8	10.4	12.0	13.6		
Coating D	AVS	Standard	—	—	—	—	—	—	—	—	—	—
	AV	Standard	5.5	7.0	8.2	10.8	11.4	13.0	13.6	16.0	17.6	
	AEX	Standard	5.3	7.0	8.2	10.8	11.4	13.0	13.6	16.0	17.6	
Nominal No.		0.5f	0.5		0.75f	0.85		1.25f	1.25			
Conductor	Number of strands/ Diameter of strand	—	7/round compression		—	11/round compression		—	16/round compression			
	Cross-sectional area (mm ²)	—	0.56		—	0.88		—	1.29			
	d (approx.)	—	0.9		—	1.1		—	1.4			
Coating D	CAVS	Standard	—	1.6	—	1.8	—	2.1				

★ "f" of nominal No. denotes "flexible".

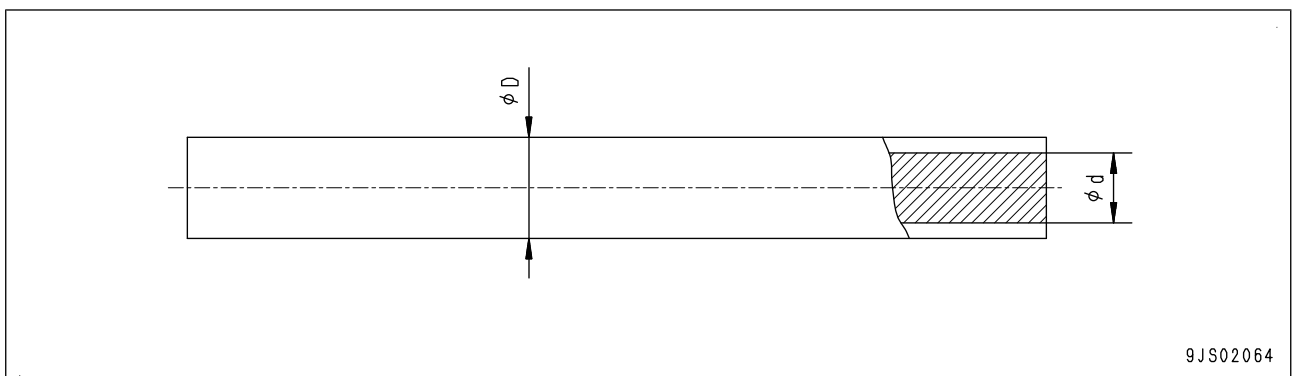

9JS02064

00 Index and foreword

Foreword, safety and general information

Color codes table

(Table 3)

Color Code	Color of wire	Color Code	Color of wire
B	Black	LgW	Light green & White
Br	Brown	LgY	Light green & Yellow
BrB	Brown & Black	LR	Blue & Red
BrR	Brown & Red	LW	Blue & White
BrW	Brown & White	LY	Blue & Yellow
BrY	Brown & Yellow	O	Orange
Ch	Charcoal	P	Pink
Dg	Dark green	R	Red
G	Green	RB	Red & Black
GB	Green & Black	RG	Red & Green
GL	Green & Blue	RL	Red & Blue
Gr	Gray	RW	Red & White
GR	Green & Red	RY	Red & Yellow
GW	Green & White	Sb	Sky Blue
GY	Green & Yellow	Y	Yellow
L	Blue	YB	Yellow & Black
LB	Blue & Black	YG	Yellow & Green
Lg	Light green	YL	Yellow & Blue
LgB	Light green & Black	YR	Yellow & Red
LgR	Light green & Red	YW	Yellow & White

★ Remarks: In a color code consisting of 2 colors, the first color is the color of the background and the second color is the color of the marking.

Examples)

GW means that the background is "Green" and marking is "White".

Types of circuits and color codes

Type of wire		AVS, AV, CAVS						AEX	
Type of circuit	Charge	R	WG	—	—	—	—	R	—
	Ground	B	—	—	—	—	—	B	—
	Start	R	—	—	—	—	—	R	—
	Light	RW	RB	RY	RG	RL	—	D	—
	Instrument	Y	YR	YB	YG	YL	YW	Y	Gr
	Signal	G	GW	GR	GY	GB	GL	G	Br
	Others	L	LW	LR	LY	LB	—	L	—
		Br	BrW	BrR	BrY	BrB	—	—	—
		Lg	LgR	LgY	LgB	LgW	—	—	—
		O	—	—	—	—	—	—	—
		Gr	—	—	—	—	—	—	—
		P	—	—	—	—	—	—	—
		Sb	—	—	—	—	—	—	—
Dg	—	—	—	—	—	—	—		
Ch	—	—	—	—	—	—	—		

Precautions when performing operation (ALL-1160-927-A-00-A)

(Rev. 2012/11)

- " When performing "testing and adjusting" of the machine, "removal and installation" and "disassembly and assembly" of the components, observe the following general cautions.

Precautions for removal and disassembly work

- " If the cooling water contains coolant, dispose of it correctly as chemicals. Do not drain it to the sewage rashly.
- " After disconnecting the hoses or tubes, plug them to prevent dirt or dust from entering.
- " When draining oil, prepare a container with sufficient capacity.
- " Check the match marks which indicate the installing position, and put match marks on the places where they seem necessary before removal of the components to prevent any mistake when assembling.
- " To prevent any excessive force from being applied to the wiring, always hold the connectors when disconnecting the connectors. Do not pull the wires.
- " Attach the tags to wires and hoses to show their installing positions to prevent any mistake when installing.
- " Check the number and thickness of the shims, and keep them in a safe place.
- " When hoisting the components, prepare the slings with sufficient strength.
- " When using forcing screws to remove any component, tighten the forcing screws uniformly and alternately.
- " Before removing any component, clean the surrounding area and cover the component to prevent any foreign material from entering after removal.
- " After disconnecting the piping or removing a pipe joint, install the following plugs.
 - ★ The O-rings in the table are emergency parts used for disassembly or transportation of the machine. When assembling, confirm the part numbers in the parts book and use the parts conforming to the using condition.

Disconnection of face seal type hoses and tubes

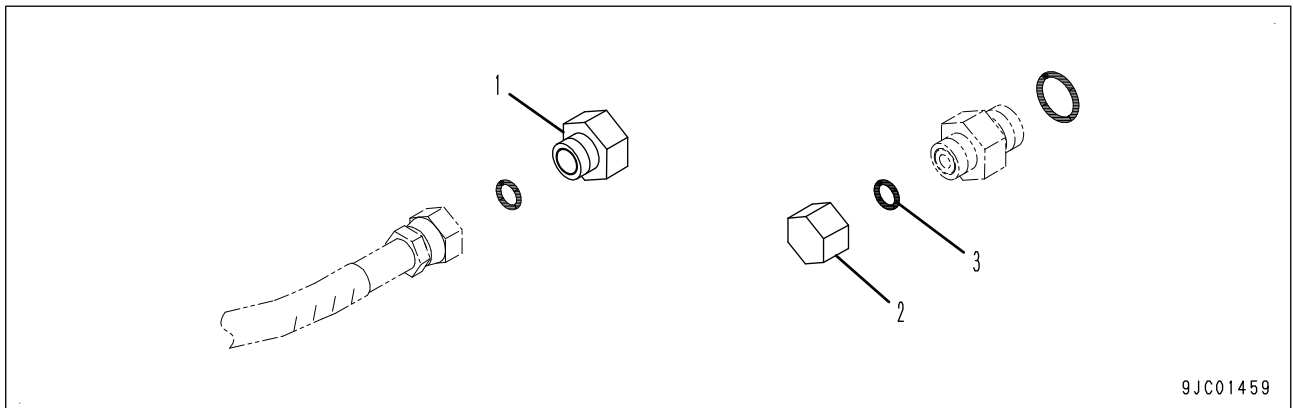

Nominal No.	Hose side	Pipe joint side	O-ring (3)
	Plug (1)	Nut (2)	
02	07376-70210	02789-00210	02896-11008
03	07376-70315	02789-00315	02896-11009
04	07376-70422	02789-00422	02896-11012
05	07376-70522	02789-00522	02896-11015
06	07376-70628	02789-00628	02896-11018

00 Index and foreword

Foreword, safety and general information

Disconnection of taper seal type hoses and tubes

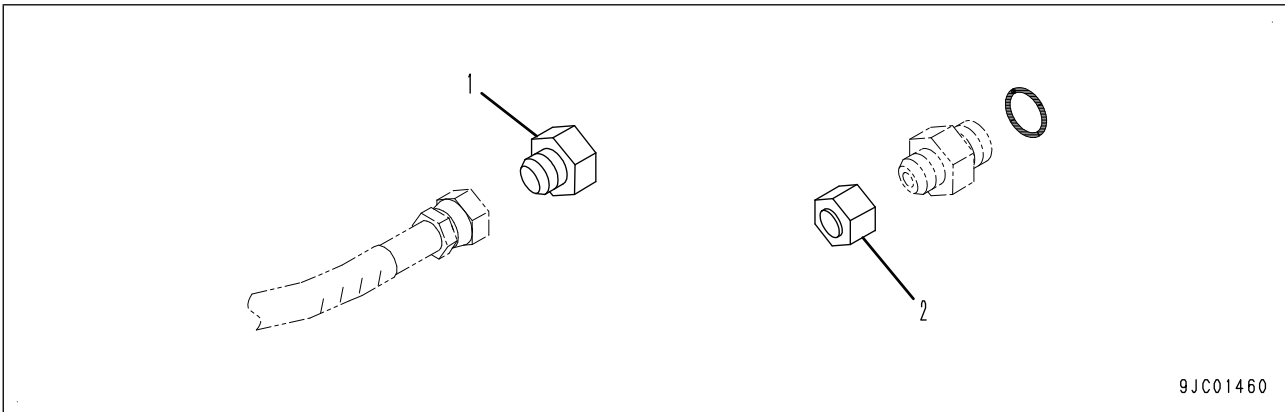

9JC01460

Nominal No.	Hose side	Pipe joint side
	Plug (1)	Nut (2)
02	07376-50210	07222-00210
03	07376-50315	07222-00312
04	07376-50422	07222-00414
05	07376-50522	07222-00515
06	07376-50628	07222-00616
10	07376-51034	07222-01018
12	07376-51234	07222-01219
14	07376-51443	07222-01422

Disconnection of split flange type hoses and tubes

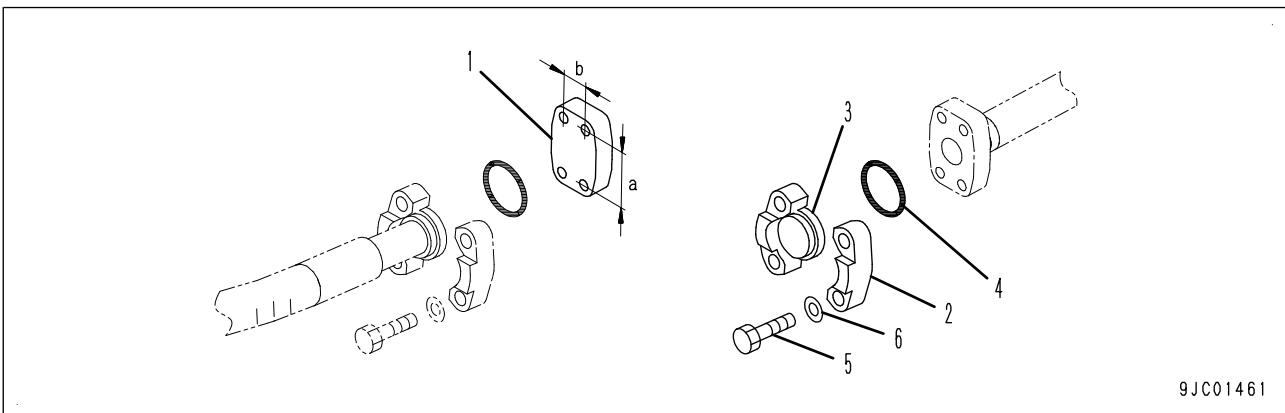

9JC01461

Nominal No.	Bolt pitch (mm)		Hose side Flange (1)	Tube side		O-ring (4)	Bolt (5)	Washer (6)
	a	b		Split flange (2)	Sleeve head (3)			
04	38.1	17.5	07379-00400	07371-30400	07378-10400	07000-12021	01010-80825	01643-50823
05	42.9	19.8	07379-00500	07371-30500	07378-10500	07000-13022	01010-80830	01643-50823
06	47.6	22.2	07379-00640	07371-30640	07378-10600	07000-13025	07372-51035	01643-51032
10	52.4	26.2	07379-01044	07371-31049	07378-11000	07000-13032	07372-51035	01643-51032
12	58.7	30.2	07379-01250	07371-31255	07378-11200	07000-13038	07372-51035	01643-51032
	66.7	31.8	07379-01260	07371-51260	07378-11210	07000-13038	01010-81245	01643-51232
14	69.9	35.8	07379-01460	07371-31465	07378-11400	07000-13048	07372-51240	01643-51232

Nominal No.	Bolt pitch (mm)		Hose side Flange (1)	Tube side		O-ring (4)	Bolt (5)	Washer (6)
	a	b		Split flange (2)	Sleeve head (3)			
	79.4	36.5	07379-01470	07371-51470	07378-11410	07000-13048	01010-81455	01643-31445
20	77.8	42.8	07379-02071	07371-32076	07378-12000	07000-12060	07372-51240	01643-51232
	96.8	44.5	07379-02080	07371-52080	07378-12010	07000-12060	01010-81865	01643-31845
24	88.9	50.8	07379-02484	07371-12484	07378-12400	07000-12070	07372-51240	01643-51232
30	106.4	62	07379-03010	07371-13010	07378-13000	07000-12085	07372-51650	01643-51645
34	120.6	69.8	07379-03411	07371-13411	07378-13400	07000-12100	07372-51650	01643-51645
40	130.2	77.8	07379-04012	07371-14012	07378-14000	07000-12110	07372-51650	01643-51645
50	152.4	92	07379-05011	07371-15011	07378-15000	07000-12135	07372-51655	01643-51645

Removal of pipe joints of O-ring boss type

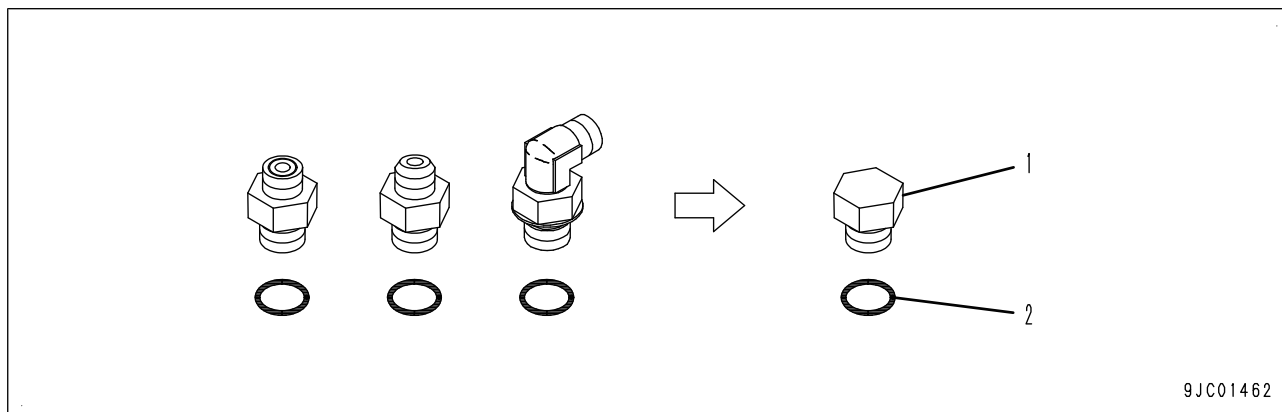

Nominal No.	Plug (1)	O-ring (2)
08	07040-10807	07002-10823
10	07040-11007	07002-11023
12	07040-11209	07002-11223
14	07040-11409	07002-11423
16	07040-11612	07002-11623
18	07040-11812	07002-11823
20	07040-12012	07002-12034
24	07040-12412	07002-12434
30	07041-13012	07002-13034
33	07040-13316	07002-13334
36	07041-13612	07002-13634
42	07040-14220	07002-14234
52	07040-15223	07002-15234

Removal of pipe joints of taper pipe thread type

00 Index and foreword

Foreword, safety and general information

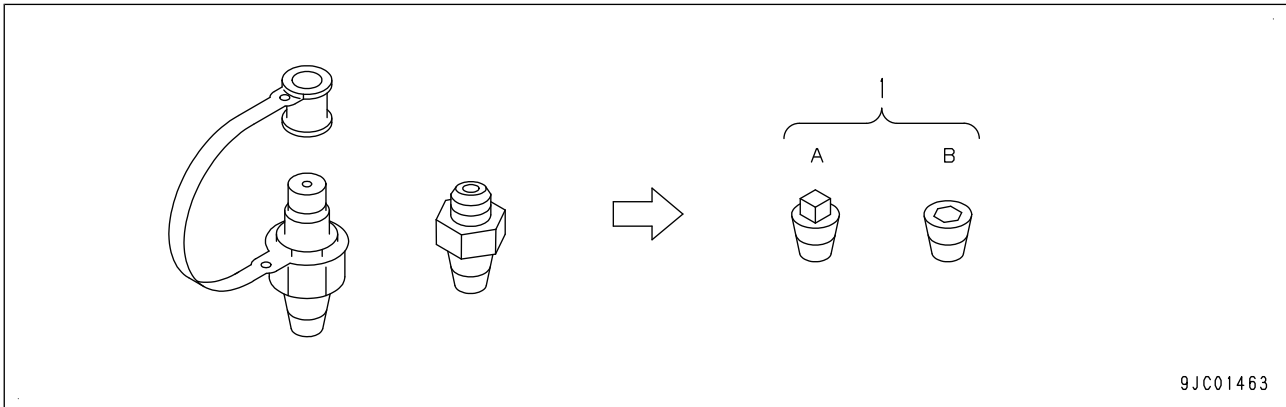

Nominal No.	Nominal thread size	Plug (1)	
		Square head type (A)	Hexagonal socket head (B)
01	R $1/8$	07042-00108	07043-00108
02	R $1/4$	07042-00211	07043-00211
03	R $3/8$	07042-00312	07043-00312
04	R $1/2$	07042-00415	07043-00415
06	R $3/4$	07042-00617	07043-00617
10	R1	07042-01019	07043-01019
12	R1 $1/4$	07042-01222	07043-01222
14	R1 $1/2$	07042-01422	07043-01422
20	R2	07042-02026	07043-02026

Precautions for installation and assembly work

- " Tighten the bolts and nuts (sleeve nuts) to the specified torque (KES), unless otherwise specified.
- " Install the hoses without twist and interference, and securely fasten the clamps located in-between if they are.
- " Replace all of the gaskets, O-rings, cotter pins, and lock plates with new parts.
- " Bend the cotter pins and lock plates securely.
- " When applying adhesive, clean and degrease the part, and apply 2 to 3 drops of adhesive to the threaded part.
- " When applying liquid gasket, clean and degrease the surface, and apply it uniformly after making sure that the surface is free from dirt or damage.
- " Clean all of the parts, and repair any damage, dents, burrs, or rust found on them.
- " Coat the rotating parts and sliding parts with engine oil.
- " Coat the surfaces of the press-fitting parts with molybdenum disulfide lubricant (LM-P).
- " After installing the snap ring, check that the snap ring is settled in the ring groove completely.
- " When connecting wiring harness connectors, clean the connectors to remove oil, dirt, or water, then connect them securely.
- " Use the eye bolts with no fatigue and deformation and screw them in securely. Match the directions of the eyes and the hook.
- " When installing split flanges, tighten the bolts uniformly and alternately to prevent excessive tightening on one side.
- " As a rule, apply liquid gasket (LG-5) or liquid sealant (LS-2) to the threaded part of each taper male screws which receives pressure.
However, if the threaded part is difficult to degrease, you may use a seal tape.
- " When winding a seal tape onto a right-handed taper male screw, wind it clockwise in the advancing direction of the threads, seeing from the screw end and starting at the third thread.
 - ★ If you wind the seal tape in the opposite direction, it becomes loose and comes off or its end part is pushed out, and that can cause oil leakage.

- ★ When the hydraulic cylinder is used for the first time after reassembly of the hydraulic equipment such as the hydraulic cylinder, pump, etc. and piping after removing them for repair, be sure to perform air bleeding of the hydraulic circuit according to the following procedure.
 1. Start the engine, and run it at low idle.
 2. Repeat the operation to extend and retract each cylinder of the work equipment to approximately 100 mm before the stroke end 4 to 5 times.
 3. Operate the hydraulic cylinder 3 to 4 times to the end of its stroke.
- ★ After the completion of repair and when operating the machine which is stored long term, perform the air bleeding with the same procedure as the one described above.

Precautions at the time of completing work

Refilling of coolant, oil and grease

- " When the coolant is drained, tighten the drain valve securely, then refill the coolant reservoir with the coolant Komatsu recommends to the specified level. Start the engine to circulate the coolant in the piping, and add the coolant to the specified level again.
- " When the hydraulic components are removed and installed, refill the oil reservoir with the oil Komatsu recommends to the specified level. Start the engine to circulate the oil in the piping, and add the oil to the specified level again.
- " If the hydraulic piping or hydraulic equipment is removed, be sure to bleed air from the system after rebuilding the parts, by referring to "Testing and adjusting".
- " Supply the specified amount of grease to the work equipment parts.

Testing installed condition of cylinder heads and manifolds

- " Check the cylinder head and intake and exhaust manifold mountings for looseness.
- " If any bolt is loose, retighten it.
 - ★ For the tightening torques, see the "Disassembly and assembly".

Testing of engine piping for damage and looseness

Intake and exhaust system	Check the piping for damage, the mounting bolts and nuts for looseness, and the joints for air suction and exhaust gas leakage. If any part is loosely installed or damaged, retighten the bolts or repair the parts.
Cooling system	Check the piping for damage, the mounting bolts and nuts for looseness, and the joints for water leakage. If any part is loosely installed or damaged, retighten the bolts or repair the parts.
Fuel system	Check the piping for damage, the mounting bolts and nuts for looseness, and the joints for fuel leakage. If any part is loosely installed or damaged, retighten the bolts or repair the parts.

Check of KDPF or muffler and exhaust pipe for damage and looseness

- " Visually check the KDPF or muffler, exhaust pipe and their mounting parts for a crack and damage. If any part is damaged, replace it.
- " Check the mounting bolts, nuts, and clamps of the KDPF or muffler, exhaust pipe and their mounting parts for looseness.
If any part is loosely installed, retighten the bolts.

Check of KDPF or muffler function

- " Check the KDPF or the muffler for unusual noise comparing to the noise when they are new.
If any unusual noise is heard, repair KDPF or muffler, referring to "Troubleshooting" and "Disassembly and assembly".

Practical use of KOMTRAX (ALL-Q210-13V-K-00-A)

(Rev. 2012/10)

KOMTRAX system transmits various machine information by use of the radio communication and KOMTRAX operator can refer this information in the office and provide various services to the customers.

When KOMTRAX is installed on the machine, the machine information can be checked through the KOMTRAX system and the testing and troubleshooting can be performed efficiently.

(KOMTRAX may not be installed on the machine in some countries or areas.)

Merit of using KOMTRAX

- " The working place of the machine can be checked in the map on PC.
- " Operation information such as service meter reading, operating hours, fuel consumption, occurred caution and failure code can be checked.
- " The hours used and replacement time of consumable parts of the machine such as fuel filter, hydraulic oil filter, hydraulic oil and engine oil can be checked.
- " The information of machine working condition (idling time, traveling time, digging time, relieving time, etc.) can be checked and the machine operating condition can be presumed with these information.
- " Various reports such as "Fuel saving operation support", "Summary of operation", etc. can be generated and utilized as an advice as well for the user and operator.

How to use KOMTRAX practically

With KOMTRAX, following support activities will be available.

1. Quick response to sudden request of repair
 - 1) When receiving a repair request from a user, check the displayed caution and failure code, etc. through KOMTRAX.
 - 2) Arrange the necessary tools, replacement parts, etc, immediately in accordance with the displayed failure code.
 - 3) By using the map of KOMTRAX, find the location of the failed machine and visit the customer there.
2. Proactive maintenance
 - 1) Check the service summary screen of KOMTRAX, and find the machine which has high priority failure code indicated by a red or yellow flag.
 - 2) Check the condition of the machine with the customer and make a plan to visit.
 - 3) Arrange necessary tools, replacement parts, etc, immediately in accordance with the displayed failure code.
3. Practice of periodic maintenance and periodic inspection service
 - 1) Check the service summary screen of KOMTRAX, and find the machine of which the usage limits for the consumable parts indicated by red flags are over.
 - 2) Submit an estimate sheet for the consumable parts to be replaced and the labor cost for the replacement work to the customer.
 - 3) Propose the periodic inspection (PM clinic, etc.) according to the service meter reading.

How to operate KOMTRAX

For the operating method of each screen of KOMTRAX, see "Global KOMTRAX Web Reference Manual (For Key Person)".

This as a preview PDF file from best-manuals.com



Download full PDF manual at best-manuals.com