

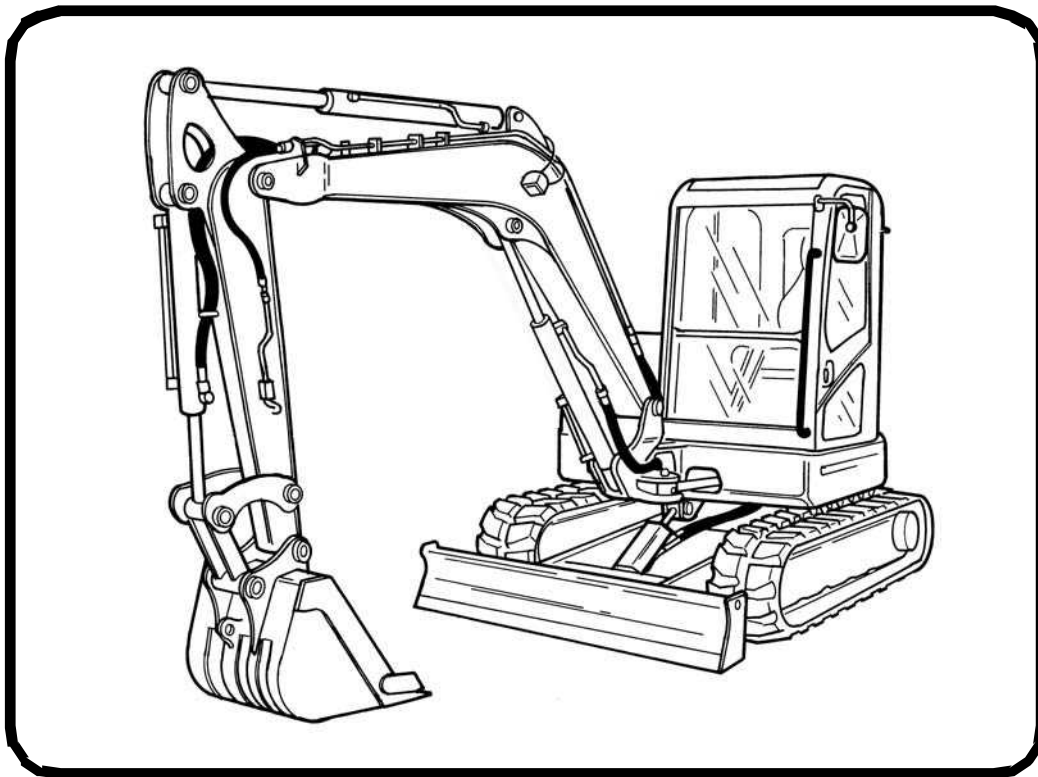

Bobcat®

Operation & Maintenance Manual E80 Compact Excavator

S/N AETB11001 & Above



OPERATOR SAFETY WARNING



WARNING

Operator must have instructions before operating the machine. Untrained operators can cause injury or death.

W-2001-0502



Safety Alert Symbol: This symbol with a warning statement, means: "Warning, be alert! Your safety is involved!" Carefully read the message that follows.

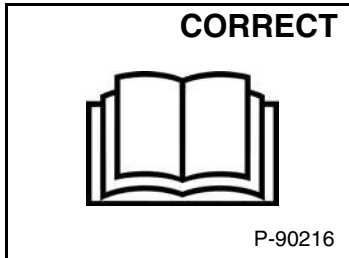

⚠ Never operate without instructions.

⚠ Read machine signs, and Operation & Maintenance Manual, and Operator's Handbook.

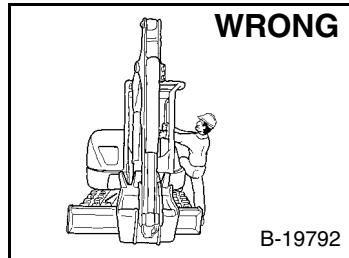

⚠ Do not grasp control handles when entering cab.

⚠ Be sure controls are in neutral before starting.

⚠ Sound horn and check behind machine before starting.

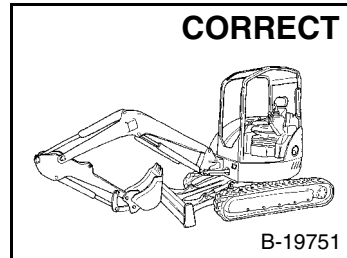

⚠ Never operate without approved cab.

⚠ Never modify equipment.

⚠ Never use attachments not approved by Bobcat Company.

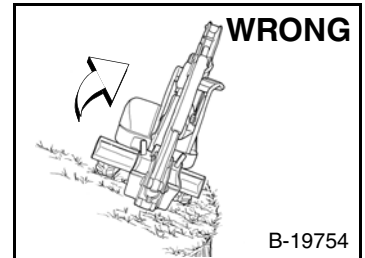

⚠ Avoid steep areas or banks that could break away.

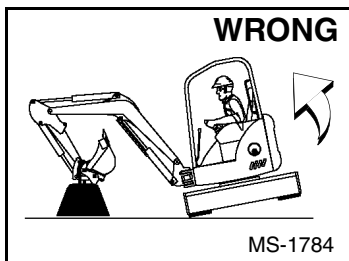

⚠ Use caution to avoid tipping - do not swing heavy load over side of track.

⚠ Operate on flat, level ground.

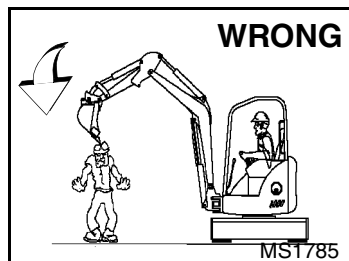

⚠ Keep bystanders out of maximum reach area.

⚠ Do not travel or turn with bucket extended.

⚠ Never carry riders.

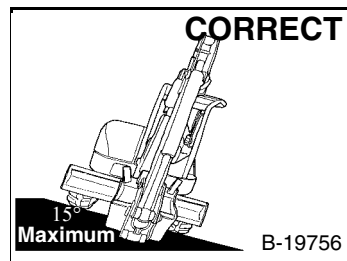

⚠ Never exceed a 15° slope to the side.

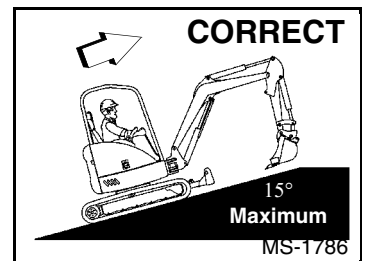

⚠ Never travel up a slope that exceeds 15°.

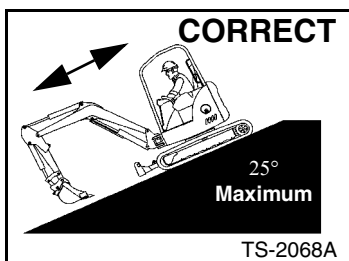

⚠ Never exceed 25° when going down or backing up a slope.

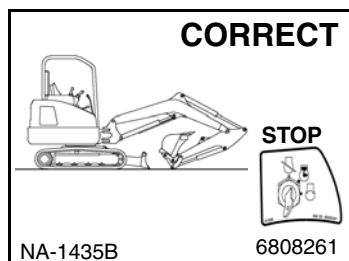

⚠ To leave excavator, lower the work equipment and the blade to the ground.

⚠ Stop the engine.

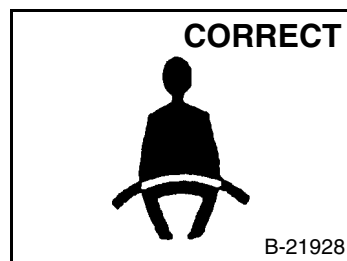

⚠ Fasten seat belt securely.

⚠ Operate controls only from operator's seat.

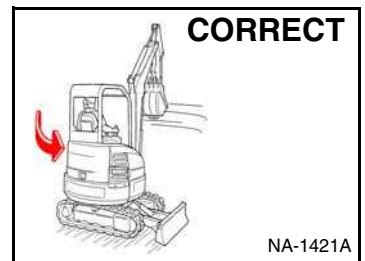

⚠ Look in the direction of rotation and make sure no bystanders are in the work area.

SAFETY EQUIPMENT

The excavator must be equipped with safety items necessary for each job. Ask your dealer about attachments and accessories.

1. SEAT BELT: Check belt fasteners and check for damaged webbing or buckle.
2. OPERATOR CAB (ROPS): Check condition and mounting hardware.
3. OPERATOR'S HANDBOOK: Must be in the cab.
4. LEFT HAND CONSOLE: When raised must deactivate the travel and hydraulic functions.
5. SAFETY SIGNS (DECALS): Replace if damaged.
6. GRAB HANDLES: Replace if damaged.
7. INTEGRATED SLEW LOCK BRAKE.



Bobcat®

CONTENTS

FOREWORD	5
SAFETY AND TRAINING RESOURCES	13
OPERATING INSTRUCTIONS	23
PREVENTIVE MAINTENANCE	77
SYSTEM SETUP AND ANALYSIS	127
MACHINE SIGN TRANSLATIONS	133
SPECIFICATIONS	151
WARRANTY	159
ALPHABETICAL INDEX	163

REFERENCE INFORMATION

Write the correct information for YOUR Bobcat excavator in the spaces below. Always use these numbers when referring to your Bobcat excavator.

Excavator Serial Number _____
Engine Serial Number _____

NOTES:

YOUR BOBCAT DEALER:

ADDRESS:

PHONE:

Bobcat Company
P.O. Box 128
Gwinner, ND 58040-0128
UNITED STATES OF AMERICA

Doosan Benelux SA
Drève Richelle 167
B-1410 Waterloo
BELGIUM



Bobcat®

FOREWORD

This Operation & Maintenance Manual was written to give the owner / operator instructions on the safe operation and maintenance of the Bobcat excavator. READ AND UNDERSTAND THIS OPERATION & MAINTENANCE MANUAL BEFORE OPERATING YOUR BOBCAT EXCAVATOR. If you have any questions, see your Bobcat dealer. This manual may illustrate options and accessories not installed on your excavator.

BOBCAT COMPANY IS ISO 9001 CERTIFIED	7
REGULAR MAINTENANCE ITEMS	7
SERIAL NUMBER LOCATIONS	9
Excavator Serial Number	9
Engine Serial Number	9
DELIVERY REPORT	9
EXCAVATOR IDENTIFICATION	10
FEATURES, ACCESSORIES AND ATTACHMENTS	11
Standard Items	11
Options And Accessories	11
Attachments	11
Buckets Available	11
Falling-Object Guards (FOGS)	12
Falling-Object Guards Kit Inspection And Maintenance	12



Bobcat®

BOBCAT COMPANY IS ISO 9001 CERTIFIED



ISO 9001 is an international standard that specifies requirements for a quality management system that controls the processes and procedures which we use to design, develop, manufacture and distribute Bobcat products.









British Standards Institute (BSI) is the Certified Registrar Bobcat Company chose to assess the Company's compliance with the ISO 9001 at Bobcat's manufacturing facilities in Gwinner and Bismarck, North Dakota (U.S.A.), Pontchateau (France), Dobris (Czech Republic) and the Bobcat corporate offices (Gwinner, Bismarck & West Fargo) in North Dakota. Only certified assessors, like BSI, can grant registrations.

ISO 9001 means that as a company we say what we do and do what we say. In other words, we have established procedures and policies, and we provide evidence that the procedures and policies are followed.

**CALIFORNIA
PROPOSITION 65 WARNING**

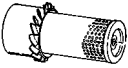
Diesel engine exhaust and some of its constituents are known to the State of California to cause cancer, birth defects and other reproductive harm.

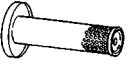
REGULAR MAINTENANCE ITEMS

	ENGINE OIL FILTER 7004996		BATTERY 7005712
	FUEL FILTER 7006269 FUEL FILTER, water separator 7005081		FLUID, Hydraulic / Hydrostatic 6903117 - (2.5 U.S. gal) 6903118 - (5 U.S. gal) 6903119 - (55 U.S. gal)
	AIR FILTER, Outer 7005000		RADIATOR CAP 7005051
	AIR FILTER, Inner 7005001		ETHYLENE GLYCOL ANTI-FREEZE, 6988096 Premixed [-37°C (-34°F)] 6988097 Concentrate
	HYDRAULIC RETURN FILTER 7004884 HYDRAULIC STRAINER / SUCTION FILTER 7006811 HYDRAULIC BREATHER FILTER 7006806		GEAR LUBE 6903121 HD 80W-90 (12 qt)
MOTOR OIL 6903105 SAE 15W/40 CE/SG (12 qt) 6903106 SAE 15W/40 CE/SG (1 U.S. gal) 6903113 SAE 15W/40 CE/SG (2.5 U.S. gal) 6903107 SAE 10W/30 CE/SG (12 qt) 6903108 SAE 10W/30 CE/SG (1 U.S. gal) 6903112 SAE 10W/30 CE/SG (2.5 U.S. gal)			

NOTE: Always verify Part Numbers with your Bobcat dealer.



Bobcat®

SERIAL NUMBER LOCATIONS

Always use the serial number of the excavator when requesting service information or when ordering parts. Early or later models (identification made by serial number) may use different parts, or it may be necessary to use a different procedure in doing a specific service operation.

Excavator Serial Number

Figure 1

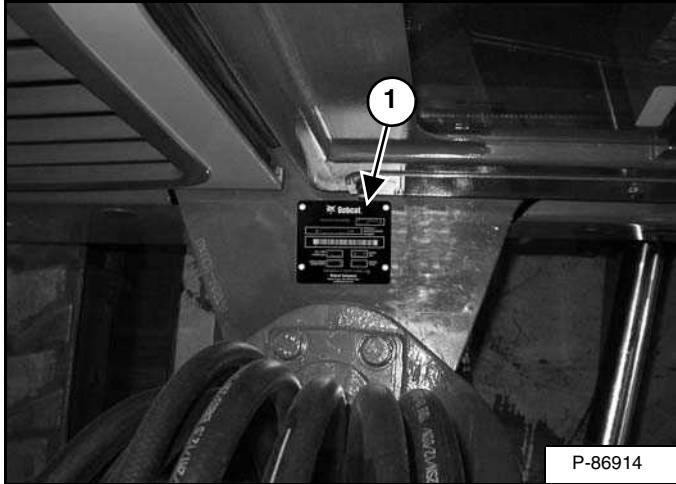

The excavator serial number plate (Item 1) [Figure 1] is located on the swing frame on the front of the upperstructure.

Explanation of Excavator Serial Number:

XXXX XXXXX

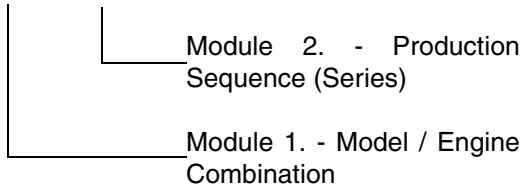

1. The four digit Model / Engine Combination Module number identifies the model number and engine combination.
2. The five digit Production Sequence Number identifies the order which the excavator is produced.

Engine Serial Number

Figure 2

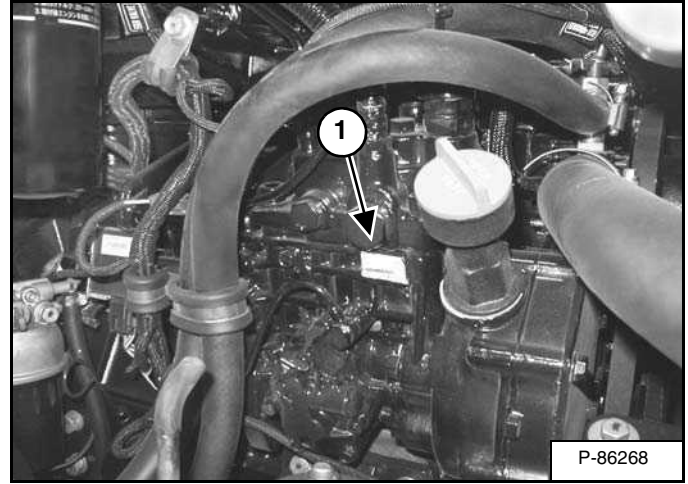

The engine serial number (Item 1) [Figure 2] is located on the top cover.

DELIVERY REPORT

Figure 3

DELIVERY REPORT

WARNING

B-16315

The delivery report [Figure 3] must be completed by the dealer and signed by the owner or operator when the Bobcat excavator is delivered. An explanation of the form must be given to the owner.

EXCAVATOR IDENTIFICATION

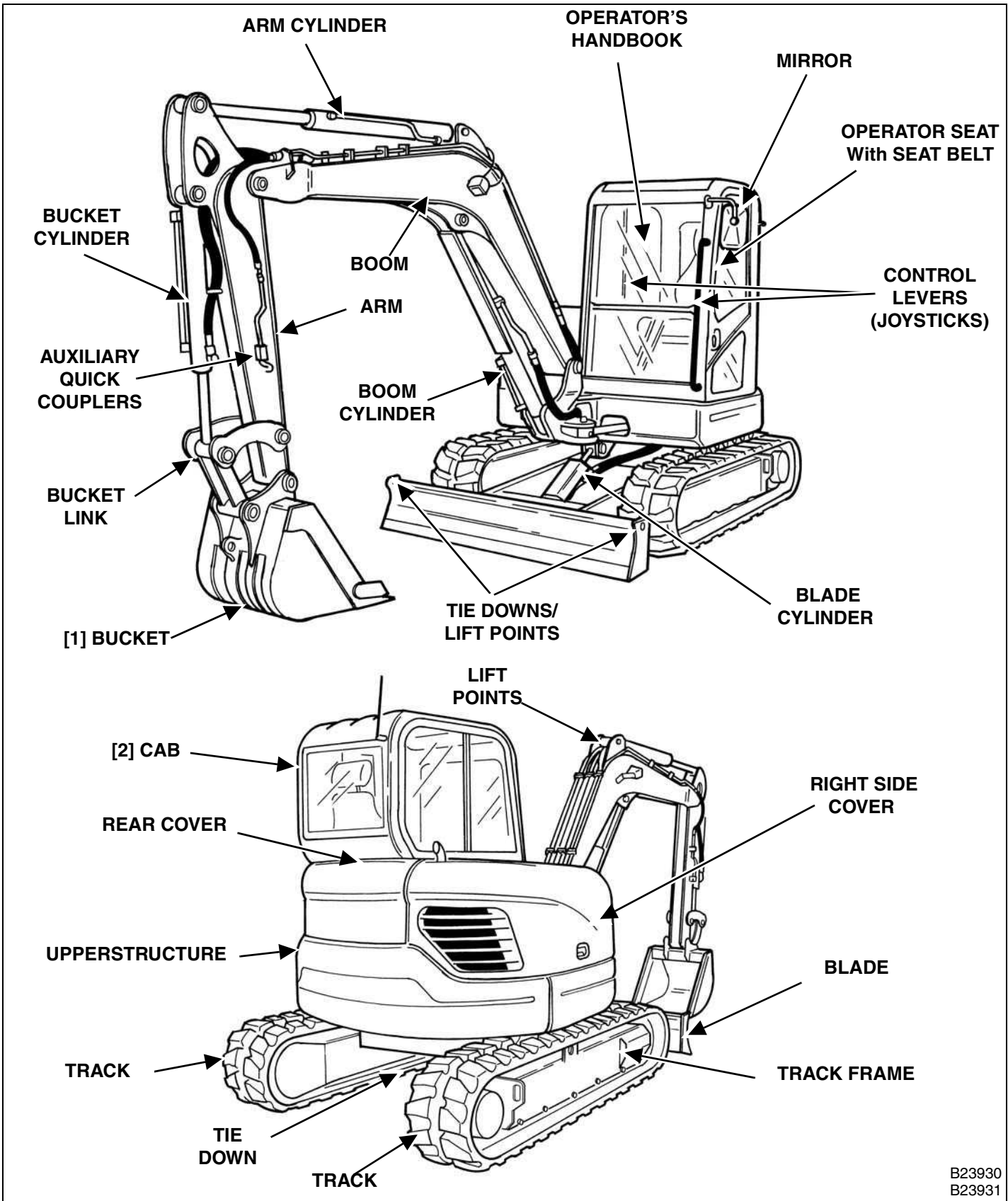

[1] BUCKET - Several different buckets and other attachments are available for the Bobcat Excavator.
 [2] ROPS / TOPS - Roll-Over Protective Structure per ISO 12117-2: 2008, and Tip-Over Protective Structure per ISO 12117: 2000.

FEATURES, ACCESSORIES AND ATTACHMENTS

Standard Items

Model E80 Bobcat excavators are equipped with the following standard items:

- Cab
- Heater and A/C
- Cab Mounted Lights
- 450 mm (17.75 in) Rubber Tracks
- 1980 mm (78.00 in) Blade
- Two-Speed Travel
- Auxiliary Hydraulics
- Hydraulic and Travel Control Lockout
- Work Lights - Boom and Frame Mounted
- Engine Monitor with Shut Down
- Horn
- Hydraulic Joystick Controls
- ISO / STD Control Pattern Selection Feature
- Suspension Seat
- Spark Arrester Muffler
- Advanced Diagnostics
- Counter Weight

Options And Accessories

Below is a list of some equipment available from your Bobcat excavator dealer as Dealer and / or Factory Installed Accessories and Factory Installed Options. See your Bobcat dealer for other available options, accessories and attachments.

- Motion Alarm
- Roof Guard Kit (FOGS)
- Roof and Front Guard Kit (FOGS)
- Steel Track
- Second Auxiliary Couplers
- 3 Inch Seat Belt
- Strobe
- Beacon
- Radio

Specifications subject to change without notice

Attachments

These and other attachments are approved for use on this model excavator. Do not use unapproved attachments. Attachments not manufactured by Bobcat may not be approved.

The versatile Bobcat excavator quickly turns into a multi-job machine with a variety of attachments.

See your Bobcat dealer for more details on these and other attachments and field accessories.

- Auger
- Breaker
- Hydraulic Clamp
- Tilt Bucket
- Ripper
- 1372 mm (54 in) Grading blade

Buckets Available

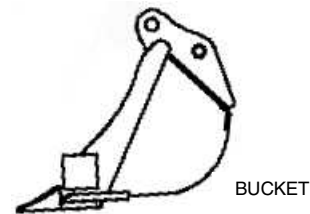

Many bucket styles, widths and different capacities are available for a variety of different applications. See your Bobcat dealer for the correct bucket for your Bobcat Excavator and application.

FEATURES, ACCESSORIES AND ATTACHMENTS (CONT'D)

Falling-Object Guards (FOGS)

Available for special applications that require protection from smaller objects that can fall on the cab and restrict material from entering cab.

The excavator must have the top guard (Item 1) and the front guard (Item 2) [Figure 4] installed to meet FOGS ISO 10262 - level 2.

See your Bobcat Dealer for availability.

Figure 4

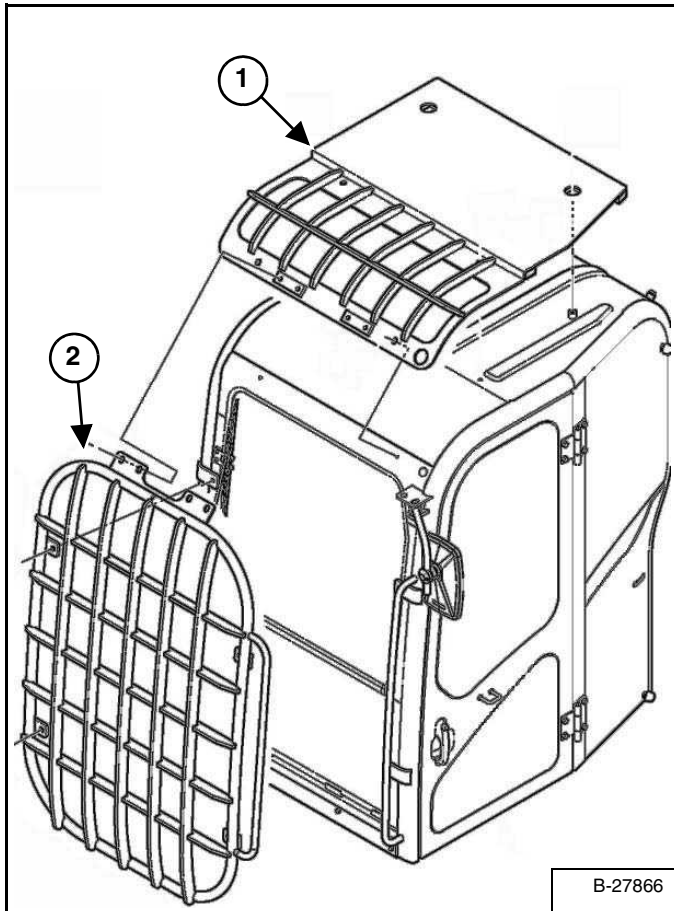

Falling-Object Guards Kit Inspection And Maintenance

The Falling Object Guards Kit must be regularly inspected and maintained. Inspect the screen for damage. Replace parts as necessary.

SAFETY AND TRAINING RESOURCES

SAFETY INSTRUCTIONS	15
Before Operation	15
Safe Operation Is The Operator's Responsibility	16
Safe Operation Needs A Qualified Operator	16
Avoid Silica Dust	17
FIRE PREVENTION	17
Maintenance	17
Operation	17
Electrical	17
Hydraulic System	18
Fueling	18
Starting	18
Spark Arrester Exhaust System	18
Welding And Grinding	18
Fire Extinguishers	18
MACHINE SIGNS (DECALS)	19
PUBLICATIONS AND TRAINING RESOURCES	21



Bobcat®

SAFETY INSTRUCTIONS

Before Operation

Carefully follow the operating and maintenance instructions in this manual.

The Bobcat excavator is highly maneuverable and compact. It is rugged and useful under a wide variety of conditions. This presents an operator with hazards associated with off highway, rough terrain applications, common with Bobcat excavator usage.

The Bobcat excavator has an internal combustion engine with resultant heat and exhaust. All exhaust gases can kill or cause illness so use the excavator with adequate ventilation.

The dealer explains the capabilities and restrictions of the Bobcat excavator and attachment for each application. The dealer demonstrates the safe operation according to Bobcat instructional materials, which are also available to operators. The dealer can also identify unsafe modifications or use of unapproved attachments. The attachments and buckets are designed for a Rated Lift Capacity. They are designed for secure fastening to the Bobcat excavator. The user must check with the dealer, or Bobcat literature, to determine safe loads of materials of specified densities for the machine - attachment combination.

The following publications and training materials provide information on the safe use and maintenance of the Bobcat machine and attachments:

- The Delivery Report is used to assure that complete instructions have been given to the new owner and that the machine and attachment is in safe operating condition.
- The Operation & Maintenance Manual delivered with the machine or attachment gives operating information as well as routine maintenance and service procedures. It is a part of the machine and can be stored in a container provided on the machine. Replacement Operation & Maintenance Manuals can be ordered from your Bobcat dealer.
- Machine signs (decals) instruct on the safe operation and care of your Bobcat machine or attachment. The signs and their locations are shown in the Operation & Maintenance Manual. Replacement signs are available from your Bobcat dealer.

- An Operator's Handbook is fastened to the operator cab of the excavator. It's brief instructions are convenient to the operator. The handbook is available from your dealer in an English edition or one of many other languages. See your Bobcat dealer for more information on translated versions.
- The AEM Safety Manual delivered with the machine gives general safety information.
- The Compact Excavator Operating Training Course is available through your Bobcat dealer. This course is intended to provide rules and practices of correct operation of the Bobcat excavator. The course is available in English and Spanish versions.
- Service Safety Training Courses are available from your Bobcat dealer. They provide information for safe and correct service procedures.
- See the PUBLICATIONS AND TRAINING RESOURCES Page in this manual or your Bobcat dealer for Service and Parts Manuals, printed materials, videos, or training courses available. Also check the Bobcat web sites www.training.bobcat.com or www.bobcat.com

The dealer and owner / operator review the recommended uses of the product when delivered. If the owner / operator will be using the machine for a different application(s) he or she must ask the dealer for recommendations on the new use.



Call Before You Dig
Dial 811 (USA Only)
1-888-258-0808 (USA & Canada)

When you call, you will be directed to a location in your state / province, or city for information about buried lines (telephone, cable TV, water, sewer, gas, etc.).

SI EXC-0913

SAFETY INSTRUCTIONS (CONT'D)

Safe Operation Is The Operator's Responsibility



Operator must have instructions before operating the machine. Untrained operators can cause injury or death.

W-2001-0502



This notice identifies procedures which must be followed to avoid damage to the machine.

I-2019-0284



The signal word DANGER on the machine and in the manuals indicates a hazardous situation which, if not avoided, will result in death or serious injury.

D-1002-1107



The signal word WARNING on the machine and in the manuals indicates a potentially hazardous situation which, if not avoided, could result in death or serious injury.

W-2044-1107

The Bobcat excavator and attachment must be in good operating condition before use.

Check all of the items on the Bobcat Service Schedule Decal under the 8-10 hour column or as shown in the Operation & Maintenance Manual.

Safe Operation Needs A Qualified Operator

For an operator to be qualified, he or she must not use drugs or alcoholic drinks which impair alertness or coordination while working. An operator who is taking prescription drugs must get medical advice to determine if he or she can safely operate a machine.

A Qualified Operator Must Do The Following:

Understand the Written Instructions, Rules and Regulations

- The written instructions from Bobcat Company include the Delivery Report, Operation & Maintenance Manual, Operator's Handbook, Safety Manual and machine signs (decals).
- Check the rules and regulations at your location. The rules may include an employer's work safety requirements. Regulations may apply to local driving requirements or use of a Slow Moving Vehicle (SMV) emblem. Regulations may identify a hazard such as a utility line.

Have Training with Actual Operation

- Operator training must consist of a demonstration and verbal instruction. This training is given by your Bobcat dealer before the product is delivered.
- The new operator must start in an area without bystanders and use all the controls until he or she can operate the machine and attachment safely under all conditions of the work area. Always fasten seat belt before operating.
- Operator Training Courses are available from your Bobcat dealer in English and Spanish. They provide information for safe and efficient equipment operation. Safety videos are also available.
- Service Safety Training Courses are available from your Bobcat dealer. They provide information for safe and correct service procedures.

Know the Work Conditions

- Know the weight of the materials being handled. Avoid exceeding the Rated Lift Capacity of the machine. Material which is very dense will be heavier than the same volume of less dense material. Reduce the size of load if handling dense material.
- The operator must know any prohibited uses or work areas, for example, he or she needs to know about excessive slopes.
- Know the location of any underground lines. Call local utilities or the TOLL FREE phone number found in the *Before Operation* section of this manual.
- Wear tight fitting clothing. Always wear safety glasses when doing maintenance or service. Safety glasses, respiratory equipment, hearing protection or Special Applications Kits are required for some work. See your Bobcat dealer about Bobcat safety equipment for your model.

SI EXC-0913

SAFETY INSTRUCTIONS (CONT'D)

Avoid Silica Dust



Cutting or drilling concrete containing sand or rock containing quartz may result in exposure to silica dust. Do not exceed Permissible Exposure Limits (PEL) to silica dust as determined by OSHA or other job site Rules and Regulations. Use a respirator, water spray or other means to control dust. Silica dust can cause lung disease and is known to the state of California to cause cancer.

FIRE PREVENTION



Maintenance

The machine and some attachments have components that are at high temperatures under normal operating conditions. The primary source of high temperatures is the engine and exhaust system. The electrical system, if damaged or incorrectly maintained, can be a source of arcs or sparks.

Flammable debris (leaves, straw, etc.) must be removed regularly. If flammable debris is allowed to accumulate, it can cause a fire hazard. Clean often to avoid this accumulation. Flammable debris in the engine compartment is a potential fire hazard.

The operator's area, engine compartment and engine cooling system must be inspected every day and cleaned if necessary to prevent fire hazards and overheating.

All fuels, most lubricants and some coolant mixtures are flammable. Flammable fluids that are leaking or spilled onto hot surfaces or onto electrical components can cause a fire.

Operation

Do not use the machine where exhaust, arcs, sparks or hot components can contact flammable material, explosive dust or gases.

Electrical



Check all electrical wiring and connections for damage. Keep the battery terminals clean and tight. Repair or replace any damaged part or wires that are loose or frayed.

Battery gas can explode and cause serious injury. Use the procedure in the Operation & Maintenance Manual for connecting the battery and for jump starting. Do not jump start or charge a frozen or damaged battery. Keep any open flames or sparks away from batteries. Do not smoke in battery charging area.

SI EXC-0913

FIRE PREVENTION (CONT'D)

Hydraulic System

Check hydraulic tubes, hoses and fittings for damage and leakage. Never use open flame or bare skin to check for leaks. Hydraulic tubes and hoses must be properly routed and have adequate support and secure clamps. Tighten or replace any parts that show leakage.

Always clean fluid spills. Do not use gasoline or diesel fuel for cleaning parts. Use commercial nonflammable solvents.

Fueling



Stop the engine and let it cool before adding fuel. No smoking! Do not refuel a machine near open flames or sparks. Fill the fuel tank outdoors.

Ultra Low Sulfur Diesel (ULSD) poses a greater static ignition hazard than earlier diesel formulations with higher Sulfur content. Avoid death or serious injury from fire or explosion. Consult with your fuel or fuel system supplier to ensure the delivery system is in compliance with fueling standards for proper grounding and bonding practices.

Starting

Do not use ether or starting fluids on any engine that has glow plugs or air intake heater. These starting aids can cause explosion and injure you or bystanders.

Use the procedure in the Operation & Maintenance Manual for connecting the battery and for jump starting.

Spark Arrester Exhaust System

The spark arrester exhaust system is designed to control the emission of hot particles from the engine and exhaust system, but the muffler and the exhaust gases are still hot.

Check the spark arrester exhaust system regularly to make sure it is maintained and working properly. Use the procedure in the Operation & Maintenance Manual for cleaning the spark arrester muffler (if equipped).

Welding And Grinding

Always clean the machine and attachment, disconnect the battery, and disconnect the wiring from the Bobcat controllers before welding. Cover rubber hoses, battery and all other flammable parts. Keep a fire extinguisher near the machine when welding.

Have good ventilation when grinding or welding painted parts. Wear dust mask when grinding painted parts. Toxic dust or gas can be produced.

Dust generated from repairing nonmetallic parts such as hoods, fenders or covers can be flammable or explosive. Repair such components in a well ventilated area away from open flames or sparks.

Fire Extinguishers

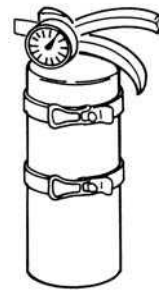

Know where fire extinguishers and first aid kits are located and how to use them. Inspect the fire extinguisher and service the fire extinguisher regularly. Obey the recommendations on the instructions plate.

This as a preview PDF file from best-manuals.com



Download full PDF manual at best-manuals.com