

# 325 and 345 Lawn and Garden Tractors (Serial No.010001–)



JOHN DEERE

## OPERATORS MANUAL

325 and 345 Lawn and Garden Tractors  
(Serial No.010001–)

OMM134133 H7 English

John Deere  
Worldwide Commercial and  
Consumer Equipment Division

OMM134133 H7

North American Version

LITHO IN U.S.A.  
ENGLISH

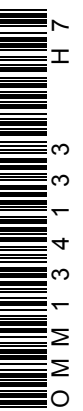

# INTRODUCTION

**THANK YOU** for purchasing a John Deere product.

Read this manual and your attachment manuals thoroughly. Failure to do so could result in personal injury or equipment damage.



**WARNING:** The Engine Exhaust from this product contains chemicals known to the State of California to cause cancer, birth defects or other reproductive harm.

CALIFORNIA Proposition 65 Warning

This manual should be considered a permanent part of your machine and should remain with the machine when you sell it. Measurements in this manual are metric units and their U.S. customary equivalents. RIGHT-HAND and LEFT-HAND sides are determined by facing in the direction the machine will travel when going forward. When you see a broken line arrow ( - - - → ) it indicates the part it is pointing to is hidden.

Record identification numbers below. Be sure to record all the numbers to help in tracing the machine if it is stolen. You also need to give these numbers to your dealer when you order parts.

**Date of Purchase:**  
\_\_\_\_\_

**Dealer Name:** \_\_\_\_\_ **Phone:** \_\_\_\_\_

**Product Identification Number:**  
□ □ □ □ □ □ □ □ □ □ □ □ □ □ □ □

**Engine Serial Number:**  
□ □ □ □ □ □ □ □ □ □ □ □ □ □ □ □

**Mower Serial Number:**  
□ □ □ □ □ □ □ □ □ □ □ □ □ □ □ □

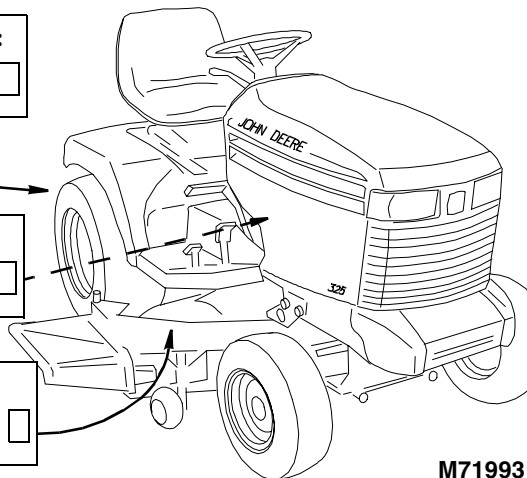

M71993

## TABLE OF CONTENTS

---

---

	Page
<b>Safety Signs</b> .....	1
<b>Controls</b> .....	5
<b>Operating The Machine</b> .....	8
<b>Operating The Mower</b> .....	36
<b>Lawn Care</b> .....	47
<b>Replacement Parts</b> .....	52
<b>Service Machine Safely</b> .....	55
<b>Service Intervals</b> .....	57
<b>Service - 325 Engine</b> .....	61
<b>Service - 345 Engine</b> .....	69
<b>Service - Transmission</b> .....	83
<b>Service - Steering</b> .....	88
<b>Service - Mower</b> .....	91
<b>Service - Electrical</b> .....	106
<b>Service - Miscellaneous</b> .....	117

## TABLE OF CONTENTS

---

---

	Page
Removing And Storing Mower.....	123
Installing Mower.....	128
Troubleshooting.....	132
Storing Vehicle.....	138
Assembly.....	141
Specifications.....	151
Warranty.....	156
Index.....	163
John Deere Service Literature.....	171

All information, illustrations and specifications in this manual are based on the latest information at the time of publication. The right is reserved to make changes at any time without notice.

COPYRIGHT© 1997  
Deere & Co.  
John Deere Worldwide Commercial and  
Consumer Equipment Division  
Horicon, WI  
All rights reserved  
Previous Editions  
COPYRIGHT© 1996,1995,1994

## NOTES

---

---

---

## NOTES

---

---

---

# SAFETY SIGNS

## Safety-Alert Symbol

Read and recognize safety information. Be alert to the potential for personal injury when you see this safety-alert symbol.

On your machine safety labels, the words DANGER, WARNING, and CAUTION are used with this safety-alert symbol. DANGER identifies the most serious hazards. In this manual, the word CAUTION and this symbol call attention to safety messages.



## Machine Safety Labels



# SAFETY SIGNS

<p><b>⚠ DANGER</b> <b>EXPLOSIVE GASES</b> Cigarettes, flames or sparks could cause battery to explode. Always shield eyes and face from battery. Do not charge or use booster cables or adjust post connections without proper instruction and training. Keep vent caps tight and level.</p>	<p><b>POISON</b> <b>CAUSES SEVERE BURNS</b> Contains sulfuric acid. Avoid contact with skin, eyes or clothing. In event of accident, flush with water and call a physician immediately. Keep out of reach of children.</p>
--	--

M74408

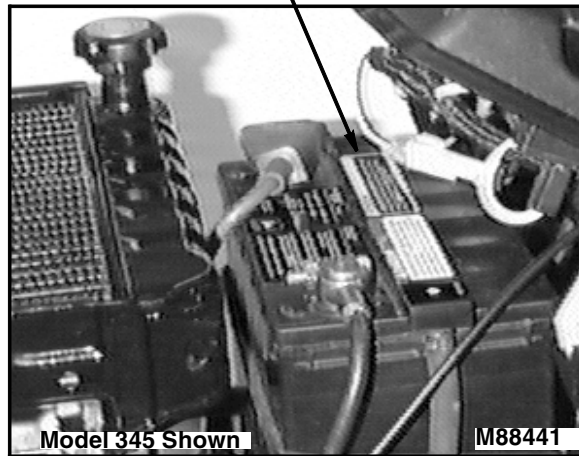

	<p><b>⚠ DANGER</b> <b>ROTATING BLADE</b> DO NOT PUT HANDS OR FEET UNDER OR INTO MOWER WHEN ENGINE IS RUNNING</p>
---	--

M38614





# SAFETY SIGNS

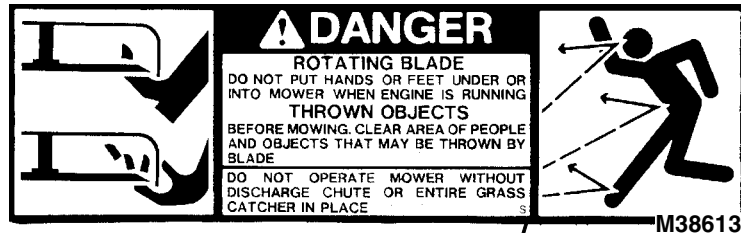

44-Inch Mower Only M47873

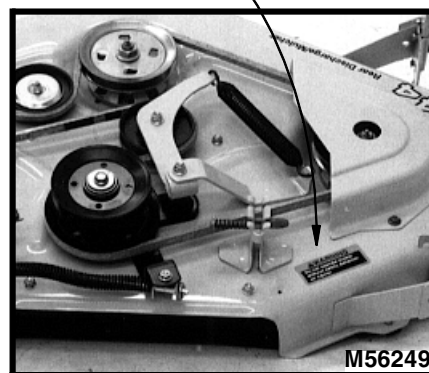

## SAFETY SIGNS

---

---

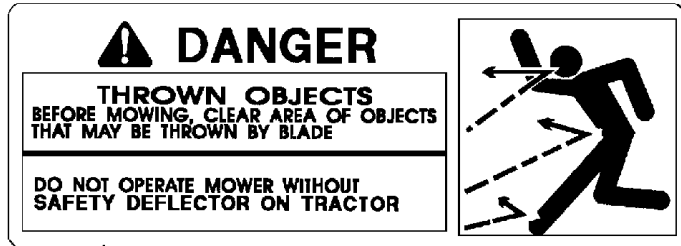

44-Inch Mower Only

M47874

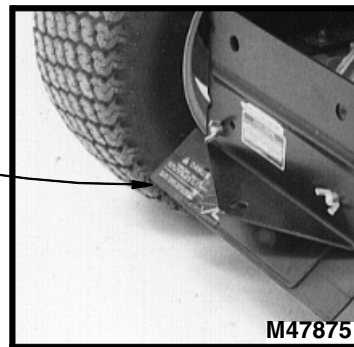

### Certification Label

This OPEI label on your mower indicates that this model has been certified by an independent laboratory for compliance with American National Standard B-71.1-1990, "Safety Specifications" for Power Lawn Mowers, Lawn and Garden Tractors, and Lawn Tractors.



# CONTROLS

---

## Dash Controls

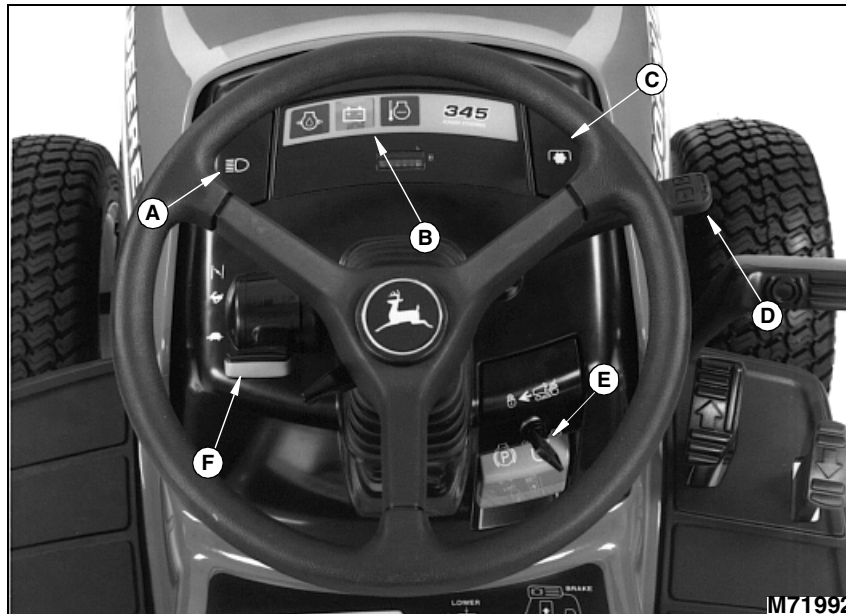

- A - Light Switch** ..... Turns headlights on and/or off.
- B - Indicator Lights**..... Monitors machine functions.
- C - PTO Switch**.....Engage and/or disengage attachments.
- D - Hydraulic Control Lever**..... Raise and/or lower attachments.
- E - Key** .....Starts engine.
- F - Throttle/Choke Lever**..... Controls engine speed and chokes engine for starting.

# CONTROLS

---

---

## Foot/Platform Controls

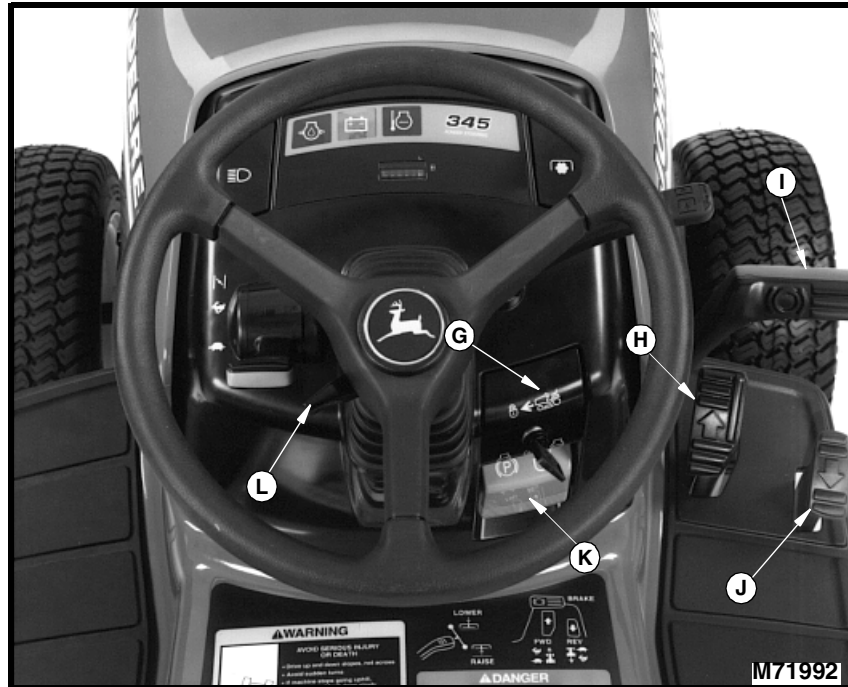

- G - Cruise Control Lever ..... Engages cruise control.**
- H - Forward Travel Pedal..... Starts machine travel.**
- I - Brake Pedal ..... Stops machine.**
- J - Reverse Travel Pedal.....Backs machine.**
- K - Park Brake Lever.....Engages park brake.**
- L - Tilt Steering Lever.....Adjusts steering wheel position.**

# CONTROLS

---

---

## Miscellaneous Controls

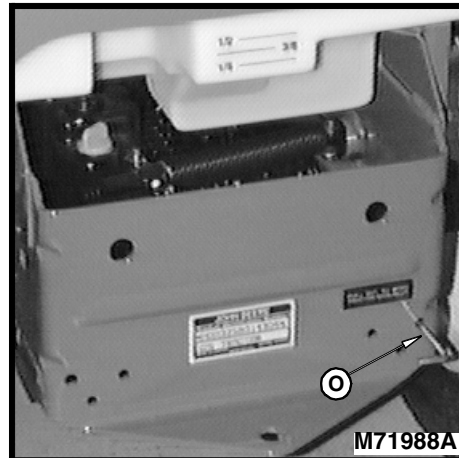

- M - Mower Height Indicator.....Indicates mower setting height.**
- N - Mower Height Knob..... Sets cutting height.**
- O - Free-Wheeling Lever..... Allows machine to be moved without the engine running.**

# OPERATING THE MACHINE

---

## Operate Safely

- Check brake action before you operate. Adjust or service brakes as necessary.
- Inspect machine before you operate. Be sure hardware is tight. Repair or replace damaged, badly worn, or missing parts. Be sure guards and shields are in good condition and fastened in place. Make any necessary adjustments before you operate.
- Clear work area of objects that might be thrown. Keep people and pets out of the work area. Stop machine if anyone enters the area.
- If you hit an object, stop the machine and inspect it. Make repairs before you operate. Keep machine and attachments properly maintained and in good working order. Keep all shields and guards in place.
- DO NOT leave machine unattended when it is running.
- Only operate during daylight or with good artificial light.
- Be careful of traffic when operating near or crossing roadways.
- Do not wear radio or music headphones while operating the machine. Safe operation requires your full attention.



## Park Safely

- Stop machine on a level surface, not on a slope.
- Disengage PTO.
- Lower attachments to the ground.
- Engage park brake.
- STOP engine.
- Remove key.
- Before you leave the operator's seat, wait for engine and all moving parts to STOP.

## OPERATING THE MACHINE

---

### **Rotating Blades are Dangerous - Protect Children and Prevent Accidents**

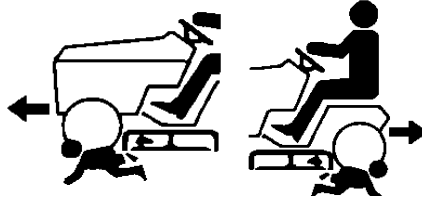

#### PROTECT CHILDREN:

- Never assume that children will remain where you last saw them. Children are attracted to mowing activity, stay alert to the presence of children.
- Keep children in the house when you are operating the machine.
- Turn machine off if a child enters the mowing area.
- Use extra care when you come to blind corners, shrubs, trees, or other objects that may block your vision.
- DO NOT let children or an untrained person operate the machine.
- DO NOT carry or let children ride on machine or any attachment. DO NOT tow children in a cart or trailer.

#### HELP PREVENT SERIOUS OR FATAL ACCIDENTS:

- Be alert at all times, drive forward carefully. People **ESPECIALLY CHILDREN** can move quickly into the mowing area before you know it.
- Back carefully. Shut off PTO and look behind the machine carefully, **ESPECIALLY FOR CHILDREN**, before you back up.
- DO NOT mow in reverse unless it is absolutely necessary.
- Shut off PTO when you are not mowing.
- DO NOT operate machine if you are under the influence of drugs or alcohol.

## OPERATING THE MACHINE

---

### Avoid Tipping

- DO NOT drive where machine could slip or tip.
- Stay alert for holes and other hidden hazards in the terrain.
- Keep away from drop-offs.
- Slow down before you make a sharp turn or operate on a slope.
- When pulling loads or using heavy equipment, use only approved hitches, limit loads to those you can safely control, and use counterweights or wheel weights when required per this manual or your attachment manual.
- Drive up and down a hill—not across. Be careful when you change direction on a slope.
- DO NOT stop when going up hill or down hill. If machine stops going up hill, STOP PTO and back down slowly.
- DO NOT mow wet grass. Reduced traction could cause sliding.
- DO NOT try to stabilize the machine by putting your foot on the ground.

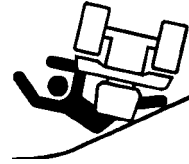

### Keep Riders Off

- Only allow the operator on the machine. Keep riders off.
- Riders on the machine or attachment may be struck by foreign objects or thrown off the machine causing serious injury.
- Riders obstruct the operator's view resulting in the machine being operated in an unsafe manner.





# OPERATING THE MACHINE

---

## Wear Appropriate Clothing

- Wear close fitting clothing and safety equipment appropriate for the job.
- Loud noise can cause impairment or loss of hearing, wear a suitable protective device such as earplugs.



## Check Wheel Bolts

- A serious accident could occur causing serious injury if wheel bolts are not tight.
- Check wheel bolt tightness often during the first 100 hours of operation.



## Transport Safely

- Use safety lights and devices. Slow moving machines when driven on public roads are hard to see, especially at night. Avoid personal injury or death resulting from a collision with a vehicle.
- Whenever driving on public roads, use flashing warning lights and turn signals according to local regulations. Extra flashing warning lights may need to be installed.



# OPERATING THE MACHINE

## Adjusting Tilt Steering Wheel



**CAUTION:** To help avoid loss of steering control:  
• Make sure steering wheel is **LOCKED** in position before operating machine.

Steering wheel has five tilt positions:

- Pull lever (A) down and push or pull wheel to a comfortable operating position.
- Push lever up to lock wheel in position.

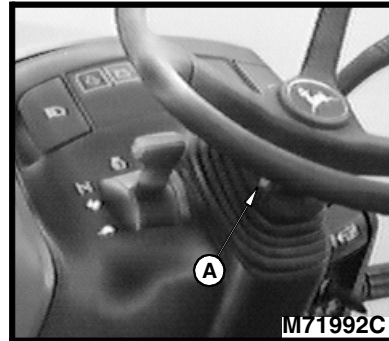

## Adjusting Seat

1. Push lever (A) to the left.
2. Slide seat forward or backward to desired position.
3. Release lever.

**NOTE:** This tractor is equipped with a fourteen position slide rail seat. Be sure seat is locked in position before operating.

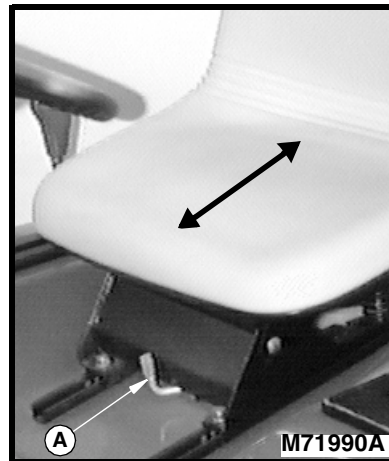

# OPERATING THE MACHINE

---

## Adjusting Rear Wheel Spacing

**NOTE:** Tractor is shipped from the factory with wheels in the narrow position.

1. Park tractor on a level surface.
2. STOP engine.
3. LOCK park brake.
4. Put blocks in front and back of front wheels.



**CAUTION:** Do not work under a raised tractor unless it is safely supported. A tractor that slips and falls off a jack could cause serious injury or death.

5. Loosen five rear wheel bolts (A). Lift rear wheels off the ground with floor jack or hoist.

6. Remove wheel bolts.

7. Install wheels in the wide position as follows:

- **Turf Tires:** Install wheel on same side of tractor with valve stem on the inside.
- **Bar Tires:** Install each wheel on opposite side of tractor. Bars on tires must point forward.

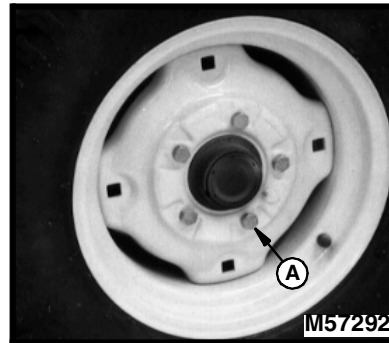

## OPERATING THE MACHINE

**NOTE: 48 and 54-Inch Mowers:** If rear tires are mounted in the wide position, move L.H. rear gage wheel (B) from the inside of gage wheel bracket (C) to the outside of gage wheel bracket. See line drawing at right.

Once this is done, the L.H. gage wheel **CANNOT** be turned 90 degrees for deck removal. (The other three still can.)

8. Tighten wheel bolts to 88 N•m (65 lb-ft).
9. Lower rear wheels to the ground. Remove blocks from front wheels.

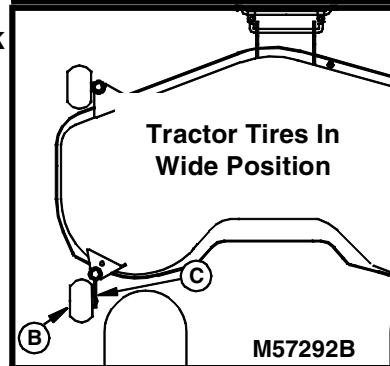
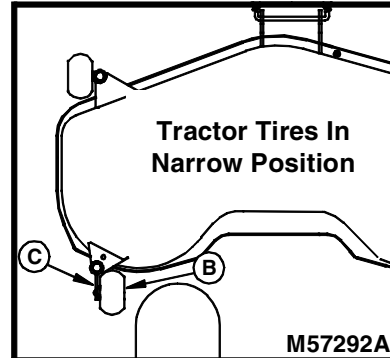

### Using the Park Brake



**CAUTION:** To avoid injury, always **LOCK** park brake before getting off tractor or leaving tractor unattended.

1. To lock park brake:
  - Push and hold brake pedal (A) all the way down.
  - Pull red park brake lever (B) up to LOCK park brake.
  - Release pedal and park brake lever. Pedal should stay down and park brake lever should stay up in LOCKED position.

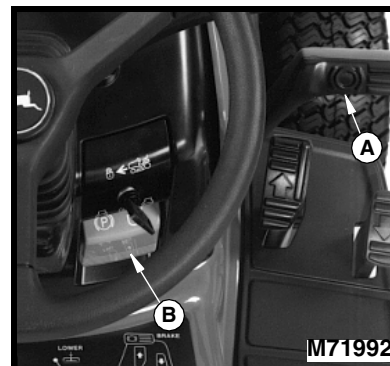

This as a preview PDF file from [best-manuals.com](http://best-manuals.com)



Download full PDF manual at [best-manuals.com](http://best-manuals.com)