

**4755 and 4955
(P.I.N. 010001-)
(P.I.N. 010001-)
Tractors**



JOHN DEERE

OPERATORS MANUAL
4755 and 4955 (P.I.N. 010001-) (P.I.N.
010001-) Tractors

OMAR112286 Issue D3 English

John Deere Waterloo Works
OMAR112286 Issue D3
(This manual replaces OMAR110570 G1)
European Edition

LITHO IN U.S.A.
ENGLISH



Introduction

READ THIS MANUAL carefully to learn how to operate and service your machine correctly. Failure to do so could result in personal injury or equipment damage.

THIS MANUAL SHOULD BE CONSIDERED a permanent part of your machine and should remain with the machine when you sell it.

MEASUREMENTS in this manual are given in both metric and customary U.S. unit equivalents. Use only correct replacement parts and fasteners. Metric and inch fasteners may require a specific metric or inch wrench.

RIGHT-HAND AND LEFT-HAND sides are determined by facing the direction of forward travel.

WRITE PRODUCT IDENTIFICATION NUMBERS (P.I.N.) in the Specification or Identification Numbers section. Accurately record all the numbers. Your dealer also needs these numbers when you order parts. File the identification numbers in a secure place off the machine.

SETTING FUEL DELIVERY BEYOND PUBLISHED factory specifications or otherwise overpowering will result in loss of warranty protection for this machine.

BEFORE DELIVERING THIS MACHINE, your dealer performed a predelivery inspection. After operating for the first 100 hours, schedule an after-sale inspection with your dealer in order to guarantee the reliable operation of the machine.

THIS TRACTOR IS DESIGNED SOLELY for use in customary agricultural operations. Use in any other way is considered as contrary to the intended use. The manufacturer accepts no liability for damage or injury resulting from this misuse, and these risks must be borne solely by the user. Compliance with and strict adherence to the conditions of operation, service and repair as specified by the manufacturer also constitute essential elements for the intended use.

THIS TRACTOR SHOULD BE OPERATED, serviced and repaired only by persons familiar with all its particular characteristics and acquainted with the relevant safety rules (accident prevention). The accident prevention regulations, all other generally recognized regulations on safety and occupational medicine and the road traffic regulations must be observed at all times. Any arbitrary modifications carried out on this tractor will relieve the manufacturer of all liability for any resulting damage or injury.

Contents

	Page		Page
Identification View	00-1	Stopping the Engine	40-10
Safety	05-1	Operating the Tractor	
Safety Signs	10-1	Emergency Steering	45-1
Controls and Instruments		Brakes	45-2
Controls		Secondary Brake	45-2
SOUND-GARD Body	15-1	Differential Lock	45-3
Tractor	15-1	Transmission Operation	45-3
Shift Console	15-2	Mechanical Front-Wheel Drive (MFWD)	45-5
Instrument Identification	15-2	Rockshaft and Three-Point Hitch	
Signals Description	15-3	Component Identification	50-1
Indicators Description	15-4	Rockshaft Controls	
Tachometer Functions	15-6	Rockshaft Troubleshooting	50-10
Performance Monitor Functions	15-9	Implement Hitch—Hook Type Draft Links	
Lighting and Signals		Attaching Implement to Quick	
Switch	20-1	Coupler—4755 and 4955 Tractors	50-16
Lamps	20-2	Adjusting Level with Quick Coupler—4755	
Electrical Outlets	20-3	and 4955 Tractors	50-18
Operator Station		Adjusting Level with Walterscheid	
SOUND-GARD Body Temperature		Hitch—4755 and 4955 Tractors	50-18
Controls	25-1	Removing Implement	50-19
Window Wipers and Washer	25-2	Hitch Conversion	50-20
Rear Window	25-2	Trailer Hitch	50-21
Seat	25-3	Remote Hydraulic Cylinders	
Steering Wheel	25-6	Hose Tips	55-1
Engine Break-in	30-1	Identifying SCV	55-1
Prestarting Checks	35-1	Connecting Cylinder Hoses	55-2
Operating the Engine		Operating SCV	55-3
Start-up Procedure	40-1	Lever Locks and Lockouts	55-6
Cold Weather Starting	40-5	Remote Cylinder Adjustments	55-7
Starting Aids	40-6	Disconnecting Cylinder Hoses	55-8
Warm-up and Operation	40-8	Adjusting SCV Linkage	55-8
		Drawbar and PTO	
		Drawbar Loads	60-1
		Clevis Assembly	60-3
		Power Take-Off (PTO) Master Shield	60-3
		PTO Adapter	60-5

Continued on next page

All information, illustrations and specifications in this manual are based on the latest information available at the time of publication. The right is reserved to make changes at any time without notice.

OMAR112286 D3-19-08APR93

COPYRIGHT© 1993
 DEERE & COMPANY
 Moline, Illinois
 All rights reserved
 A John Deere ILLUSTRATION® Manual
 Previous Editions
 Copyright 1991 Deere & Company

Contents

	Page		Page
Attaching PTO Driven Implement	60-5	Lubrication and Maintenance/Annual	115-1
Operating PTO	60-6	Lubrication and Maintenance/2 Year	120-1
Ballast		Lubrication and Maintenance/As Required	125-1
Guidelines	65-1	Troubleshooting	
Measuring Wheel Slip	65-2	Engine	130-1
Determining Ballast	65-3	Transmission	130-4
Liquid Weight	65-4	Hydraulic	130-5
Rear Cast Iron Weights	65-5	Brakes	130-5
Installing QUIK-TATCH Weights	65-6	Rockshaft Three-Point Hitch	130-6
Wheels, Tires and Treads		Remote Hydraulic Cylinders	130-7
Guidelines	70-1	Electrical	130-8
Implement-To-Tire Clearance	70-2	SOUND-GARD Body	130-9
Inflation Pressures	70-3	Service	
Tire Combinations	70-6	Access	135-1
Tightening Wheel Bolts	70-7	Air Cleaner	135-3
Toe-In	70-8	Belts	135-6
Front Tread Settings	70-10	Fuel System	135-9
Steering Stops	70-15	Cooling System	135-12
Adjust Front Fenders	70-18	Electrical	135-16
Adjusting Rear Wheels	70-19	Fuses	135-21
Rear Tread Settings	70-24	Lighting	135-23
Transporting		Brakes	135-30
Driving	75-1	Tires	135-31
Hauling	75-3	Heating and Air Conditioning	135-33
Towing	75-4	Roll-Over Protective Structure (ROPS)	135-37
Fuels, Lubricants and Coolant		Storage	140-1
Fuel	80-1	Specifications	145-1
Engine Oil	80-3	Ground Speeds	145-5
Engine Coolant	80-4	Torque Chart	145-6
Transmission-Hydraulic Oil	80-5	Identification Numbers	
Lubricants	80-6	Serial Number Plates	150-1
Lubrication and Maintenance		Daily Maintenance	155-1
Break-In Service	85-2	Lubrication and Maintenance Records	160-1
Service Intervals Chart	85-3	Index	
Lubrication and Maintenance/10 Hour	90-1		
Lubrication and Maintenance/250 Hour	95-1		
Lubrication and Maintenance/750 Hour	100-1		
Lubrication and Maintenance/1000 Hour	105-1		
Lubrication and Maintenance/1500 Hour	110-1		

Identification View



RX,110570,00,1 -19-02JUL91

RW19453 -UN-09JUL91

Safety

RECOGNIZE SAFETY INFORMATION

This is the safety-alert symbol. When you see this symbol on your machine or in this manual, be alert to the potential for personal injury.

Follow recommended precautions and safe operating practices.

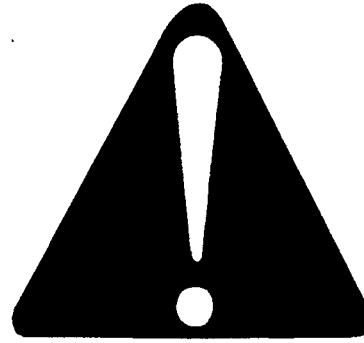

DX,ALERT -19-03MAR93

T81389 -UN-07DEC88

UNDERSTAND SIGNAL WORDS

A signal word—DANGER, WARNING, or CAUTION—is used with the safety-alert symbol. DANGER identifies the most serious hazards.

DANGER or WARNING safety signs are located near specific hazards. General precautions are listed on CAUTION safety signs. CAUTION also calls attention to safety messages in this manual.



DX,SIGNAL -19-03MAR93

TS187 -19-30SEP88

FOLLOW SAFETY INSTRUCTIONS

Carefully read all safety messages in this manual and on your machine safety signs. Keep safety signs in good condition. Replace missing or damaged safety signs. Be sure new equipment components and repair parts include the current safety signs. Replacement safety signs are available from your John Deere dealer.

Learn how to operate the machine and how to use controls properly. Do not let anyone operate without instruction.

Keep your machine in proper working condition. Unauthorized modifications to the machine may impair the function and/or safety and affect machine life.

If you do not understand any part of this manual and need assistance, contact your John Deere dealer.



DX,READ -19-03MAR93

TS201 -UN-29AUG88



STAY CLEAR OF MOVING TRACTOR

Always place transmission in PARK before dismounting. Leaving transmission in gear with engine stopped will NOT prevent the tractor from moving.

Be sure everyone is clear of tractor and attached equipment before starting engine. Some movement may occur as engine starts.

Never try to get on or off a moving tractor.

When tractor is left unattended, place in PARK, lower implements to the ground, stop the engine, and remove the key.

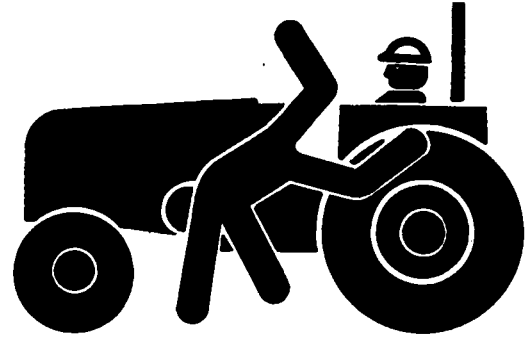

TS213 -UN-23AUG88

RX,STAY,CLEAR -19-25JUL89

PREVENT MACHINE RUNAWAY

Avoid possible injury or death from machinery runaway.

Do not start engine by shorting across starter terminals. Machine will start in gear if normal circuitry is bypassed.

NEVER start engine while standing on ground. Start engine only from operator's seat, with transmission in neutral or park.

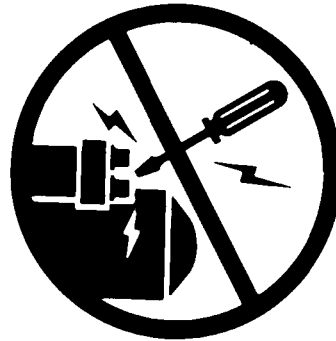

TS177 -UN-11JAN89

DX,BYPAS1 -19-03MAR93

USE SEAT BELT

Use a seat belt to minimize chance of injury from an accident such as a roll-over.

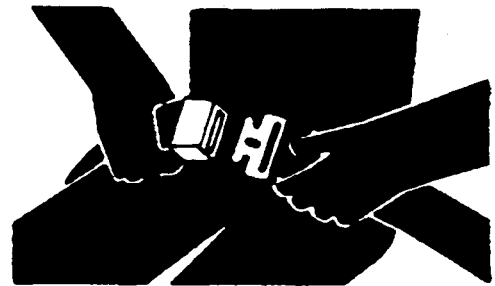

RW16064 -UN-05JAN89

RX,ROPS1 -19-22SEP92



OPERATING THE TRACTOR SAFELY

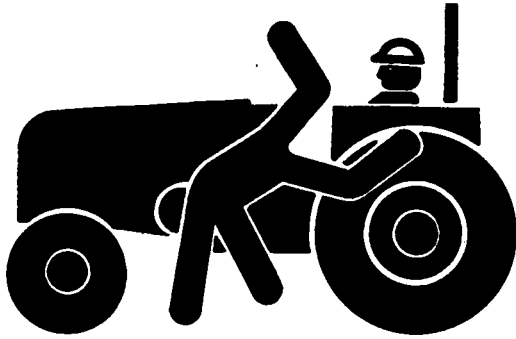

TS213 -UN-23AUG88



TS276 -UN-23AUG88

Careless use of the tractor can result in unnecessary accidents. Be alert to hazards of tractor operation. Understand causes of accidents and take every precaution to avoid them. Most common accidents are caused from:

- Tractor roll-over
- Improper starting procedures
- Crushing and pinching during hitching
- Collisions with other motor vehicles
- Entanglement in PTO shafts
- Falling from tractor

Avoid accidents by taking the following precautions:

- Put transmission in PARK before dismounting. Leaving transmission in gear with engine stopped will NOT prevent the tractor from moving.
- Be sure everyone is clear of tractor and attached equipment before starting engine.
- Never try to get on or off a moving tractor.
- When tractor is left unattended, place in PARK, lower implements to the ground, stop the engine, and remove the key.

RX,HAZARD,S -19-22SEP92



USE CAUTION ON HILLSIDES

Avoid holes, ditches, and obstructions which may cause tractor roll-over, especially on hillsides. Avoid sharp turns on hills.

Never drive near the edge of a gully or steep embankment.

Driving out of a ditch, mired condition, or up a steep slope could cause tractor to tip over rearward. Back out of these situations if possible.

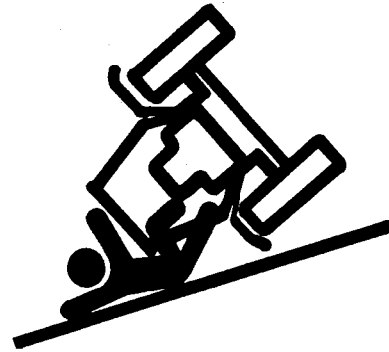

RX,HILL,SIDE1 -19-22SEP92

-UN-07DEC88
RW13093

STOPPING AND PARKING TRACTOR

Tractor roll-over, collisions, runaway tractors, and people being crushed under machines and implements can happen when operators ignore safety.

To avoid these accidents, take some precautions:

- Signal before stopping, turning, or slowing down on public roads
- Pull over to side of road before stopping
- Slow down before braking
- Pump brakes when stopping on slippery surfaces
- Be careful when towing and stopping heavy loads
- Shift to park or apply parking brake
- Lower all equipment when leaving tractor
- Remove key

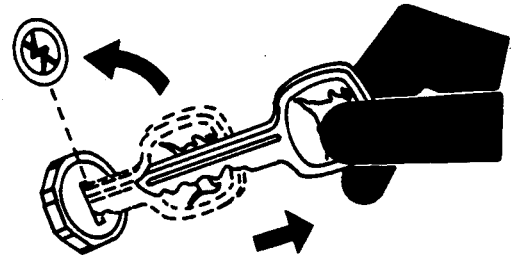

RX,STOP,PARK -19-21SEP92

-UN-24MAY89
TS230



WORK IN VENTILATED AREA

Engine exhaust fumes can cause sickness or death. If it is necessary to run an engine in an enclosed area, remove the exhaust fumes from the area with an exhaust pipe extension.

If you do not have an exhaust pipe extension, open the doors and get outside air into the area.



DX,AIR

-19-04JUN90

TS220
-UN-23AUG88

KEEP RIDERS OFF MACHINE

Only allow the operator on the machine. Keep riders off.

Riders on machine are subject to injury such as being struck by foreign objects and being thrown off of the machine. Riders also obstruct the operator's view resulting in the machine being operated in an unsafe manner.

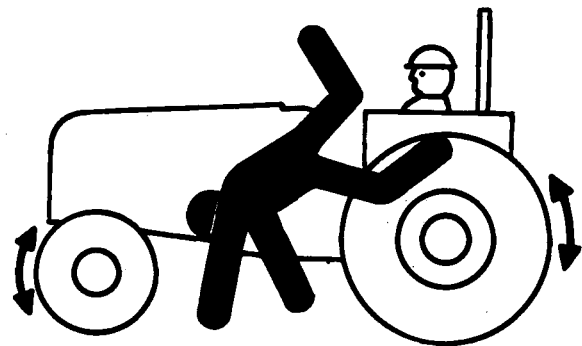

DX,RIDER

-19-03MAR93

TS290
-UN-23AUG88

AVOID EYE CONTACT WITH RADAR

Radar ground speed sensor emits a very low intensity microwave signal. It will not cause any ill effects during normal use. Although intensity is low, DO NOT look directly into face of sensor while in operation, to avoid any possible eye damage.

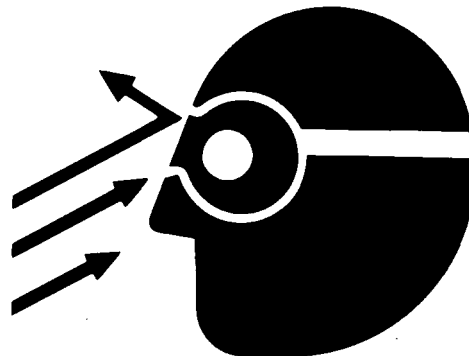

RX,SAFTY,RADAR1-19-21SEP92

TS266
-UN-23AUG88

HANDLE FUEL SAFELY—AVOID FIRES

Handle fuel with care: it is highly flammable. Do not refuel the machine while smoking or when near open flame or sparks.

Always stop engine before refueling machine. Fill fuel tank outdoors.

Prevent fires by keeping machine clean of accumulated trash, grease, and debris. Always clean up spilled fuel.



DX,FIRE1

-19-03MAR93

TS202
-UN-23AUG88



PREPARE FOR EMERGENCIES

Be prepared if a fire starts.

Keep a first aid kit and fire extinguisher handy.

Keep emergency numbers for doctors, ambulance service, hospital, and fire department near your telephone.

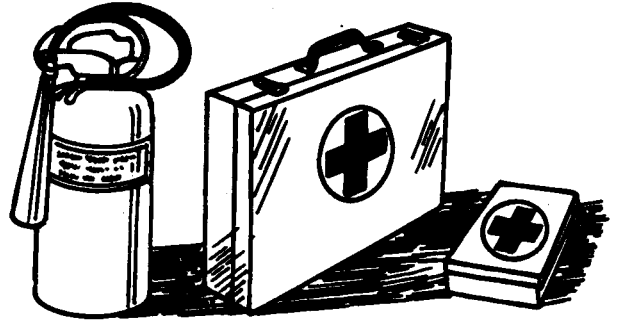

DX,FIRE2 -19-03MAR93

TS291 -UN-23AUG88

HANDLE STARTING FLUID SAFELY

Starting fluid is highly flammable.

Keep all sparks and flame away when using it. Keep starting fluid away from batteries and cables.

To prevent accidental discharge when storing the pressurized can, keep the cap on the container, and store in a cool, protected location.

Do not incinerate or puncture a starting fluid container.



DX,FIRE3 -19-16APR92

TS1356 -UN-18MAR92

WEAR PROTECTIVE CLOTHING

Wear close fitting clothing and safety equipment appropriate to the job.

Operating equipment safely requires the full attention of the operator. Do not wear radio or music headphones while operating machine.

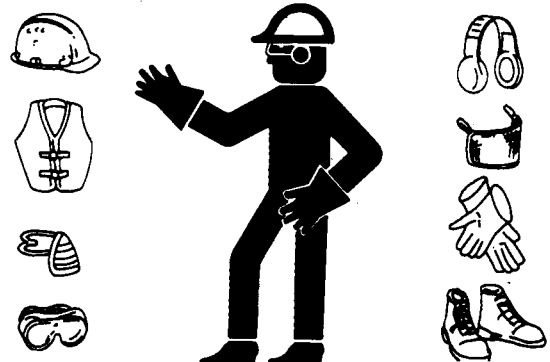

DX,WEAR2 -19-03MAR93

TS206 -UN-23AUG88



AVOID CONTACT WITH PESTICIDES

This enclosed cab does not protect against inhaling harmful pesticides. If pesticide use instructions require respiratory protection, wear an appropriate respirator inside the cab.

Before leaving the cab, wear personal protective equipment as required by the pesticide use instructions. When re-entering the cab, remove protective equipment and store either outside the cab in a closed box or some other type of sealable container or inside the cab in a pesticide resistant container, such as a plastic bag.

Clean your shoes or boots to remove soil or other contaminated particles prior to entering the cab.

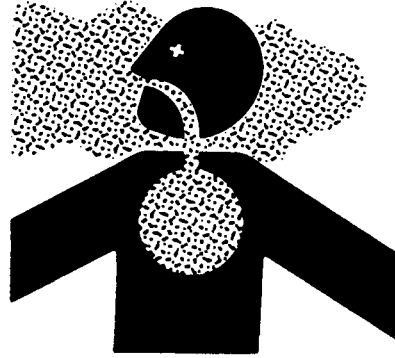

DX,CABS -19-03MAR93

-UN-23AUG88

TS220

-UN-23AUG88

TS272

STAY CLEAR OF ROTATING DRIVELINES

Entanglement in rotating driveline can cause serious injury or death.

Keep tractor master shield and driveline shields in place at all times. Make sure rotating shields turn freely.

Wear close fitting clothing. Stop the engine and be sure PTO driveline is stopped before making adjustments, connections, or cleaning out PTO driven equipment.



DX,PTO -19-03MAR93

-UN-23AUG88

TS198



USE SAFETY LIGHTS AND DEVICES

Slow moving tractors, self-propelled equipment and towed implements or attachments can create a hazard when driven on public roads. They are difficult to see, especially at night. Avoid personal injury or death resulting from collision with a vehicle.

Whenever driving on public roads, use flashing warning lights and turn signal according to local regulation. To increase visibility, use the lights and devices provided with your machine. For some equipment, install extra flashing warning lights.

Keep safety items in good condition. Replace missing or damaged items. An implement safety lighting kit is available from your John Deere dealer.

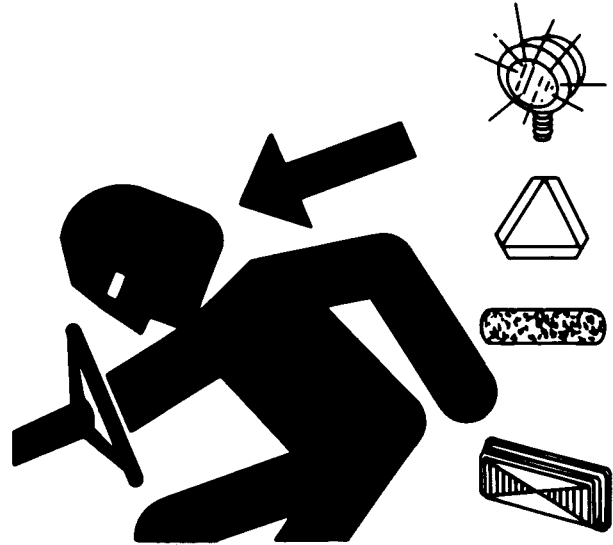

DX,FLASH -19-15MAR93

TS951 -UN-12APR90

USE A SAFETY CHAIN

A safety chain will help control drawn equipment should it accidentally separate from the drawbar.

Using the appropriate adapter parts, attach the chain to the tractor drawbar support or other specified anchor location. Provide only enough slack in the chain to permit turning.

See your John Deere dealer for a chain with a strength rating equal to or greater than the gross weight of the towed machine. Do not use safety chain for towing.

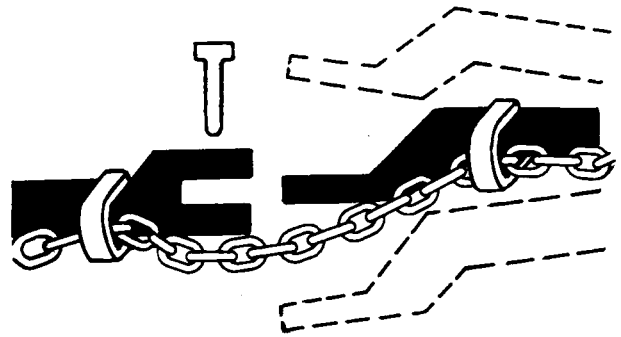

DX,CHAIN -19-03MAR93

TS217 -UN-23AUG88

TRANSPORT TRACTOR SAFELY

Transport a disabled tractor on a flatbed carrier. Securely chain tractor to carrier.

If towing a tractor, never tow faster than 16 km/h (10 mph) with rear wheels raised or faster than 8 km/h (5 mph) with all wheels on the ground. Have an operator steer and brake tractor.

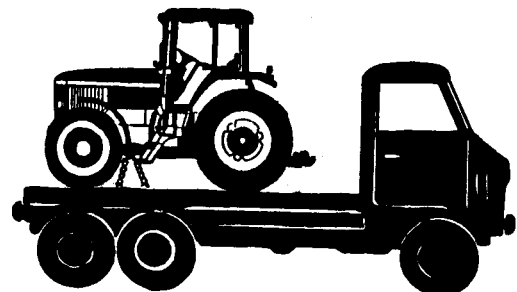

RX,HAUL,IT1 -19-21SEP92

RW22056 -UN-04DEC92



REDUCE SPEED WHEN TOWING LOADS

Braking to stop towed loads from transport speeds can cause the towed load to swerve and upset. Reduce speed if towed load weighs more than the tractor and is not equipped with brakes.

Follow recommended speed-weight ratio guidelines:

- Maximum speed is 32 km/h (20 mph) when towing load equal to or less in weight than the tractor.
- Reduce speed to 16 km/h (10 mph) when towing load up to double the tractor weight.
- Do not tow loads exceeding double the tractor weight.
- Use additional caution when towing loads under adverse surface conditions, when turning, and on inclines.

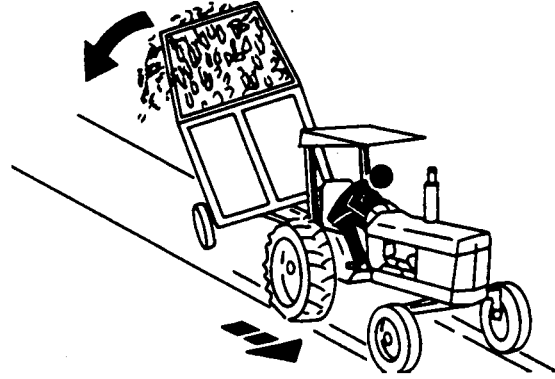

TS216 -UN-23AUG88

DX,TOW -19-03MAR93

KEEP ROPS INSTALLED PROPERLY

Make certain all parts are reinstalled correctly if the roll-over protective structure (ROPS) is loosened or removed for any reason. Tighten mounting bolts to proper torque.

The protection offered by ROPS will be impaired if ROPS is subjected to structural damage, is involved in an overturn incident, or is in any way altered by welding, bending, drilling, or cutting. A damaged ROPS should be replaced, not reused.

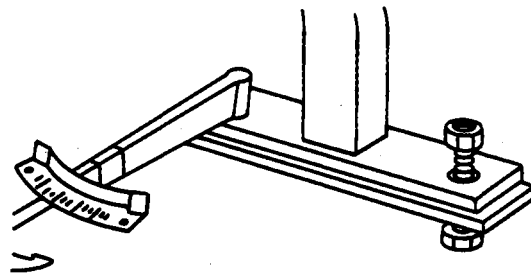

TS212 -UN-23AUG88

DX,ROPS3 -19-03MAR93



SERVICE COOLING SYSTEM SAFELY

Explosive release of fluids from pressurized cooling system can cause serious burns.

Shut off engine. Only remove filler cap when cool enough to touch with bare hands. Slowly loosen cap to first stop to relieve pressure before removing completely.



DX,RCAP

-19-04JUN90

TS281
-UN-23AUG88

PRACTICE SAFE MAINTENANCE

Understand service procedure before doing work. Keep area clean and dry.

Never lubricate, service, or adjust machine while it is moving. Keep hands, feet, and clothing from power-driven parts. Disengage all power and operate controls to relieve pressure. Lower equipment to the ground. Stop the engine. Remove the key. Allow machine to cool.

Securely support any machine elements that must be raised for service work.

Keep all parts in good condition and properly installed. Fix damage immediately. Replace worn or broken parts. Remove any buildup of grease, oil, or debris.

Disconnect battery ground cable (-) before making adjustments on electrical systems or welding on machine.



DX,SERV

-19-03MAR93

TS218
-UN-23AUG88



REMOVE PAINT BEFORE WELDING OR HEATING

Avoid potentially toxic fumes and dust.

Hazardous fumes can be generated when paint is heated by welding, soldering, or using a torch.

Do all work outside or in a well ventilated area. Dispose of paint and solvent properly.

Remove paint before welding or heating:

- If you sand or grind paint, avoid breathing the dust. Wear an approved respirator.
- If you use solvent or paint stripper, remove stripper with soap and water before welding. Remove solvent or paint stripper containers and other flammable material from area. Allow fumes to disperse at least 15 minutes before welding or heating.



TS220 -UN-23AUG88

DX,PAINT -19-03MAR93

AVOID HEATING NEAR PRESSURIZED FLUID LINES

Flammable spray can be generated by heating near pressurized fluid lines, resulting in severe burns to yourself and bystanders. Do not heat by welding, soldering, or using a torch near pressurized fluid lines or other flammable materials. Pressurized lines can be accidentally cut when heat goes beyond the immediate flame area.



TS953 -UN-15MAY90

DX,TORCH -19-03MAR93



AVOID HIGH-PRESSURE FLUIDS

Escaping fluid under pressure can penetrate the skin causing serious injury.

Avoid the hazard by relieving pressure before disconnecting hydraulic or other lines. Tighten all connections before applying pressure.

Search for leaks with a piece of cardboard. Protect hands and body from high pressure fluids.

If an accident occurs, see a doctor immediately. Any fluid injected into the skin must be surgically removed within a few hours or gangrene may result. Doctors unfamiliar with this type of injury should reference a knowledgeable medical source. Such information is available from Deere & Company Medical Department in Moline, Illinois, U.S.A.

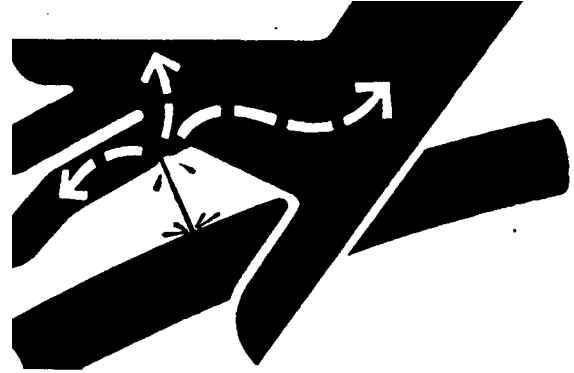

X9811 -UN-23AUG88

DX,FLUID -19-03MAR93

SERVICE BRAKE ACCUMULATOR SAFELY

Accumulator contains gas and oil under pressure. To avoid injury from escaping fluid, relieve all pressure from accumulator before disconnecting brake accumulator or brake valve. To do so open bleed screws and pump brake pedal with engine stopped, until pedal easily goes all the way down.

The accumulator is charged with dry nitrogen to a pressure of 500 psi (3450 kPa) (35 bar). If it needs recharging, have job done only by a qualified service person and only with dry nitrogen.



X9811 -UN-23AUG88

RX,BRAKE,FIX -19-26JUL89



AVOID HARMFUL ASBESTOS DUST

Avoid breathing dust that may be generated when handling components containing asbestos fibers. Inhaled asbestos fibers may cause lung cancer.

Components in products that may contain asbestos fibers are brake pads, brake band and lining assemblies, clutch plates, and some gaskets. The asbestos used in these components is usually found in a resin or sealed in some way. Normal handling is not hazardous as long as airborne dust containing asbestos is not generated.

Avoid creating dust. Never use compressed air for cleaning. Avoid brushing or grinding material containing asbestos. When servicing, wear an approved respirator. A special vacuum cleaner is recommended to clean asbestos. If not available, apply a mist of oil or water on the material containing asbestos.

Keep bystanders away from the area.



TS220 -UN-23AUG88

DX,DUST -19-15MAR91

STORE ATTACHMENTS SAFELY

Stored attachments such as dual wheels, cage wheels, and loaders can fall and cause serious injury or death.

Securely store attachments and implements to prevent falling. Keep playing children and bystanders away from storage area.



TS219 -UN-23AUG88

DX,STORE -19-03MAR93



DISPOSE OF WASTE PROPERLY

Improperly disposing of waste can threaten the environment and ecology. Potentially harmful waste used with John Deere equipment include such items as oil, fuel, coolant, brake fluid, filters, and batteries.

Use leakproof containers when draining fluids. Do not use food or beverage containers that may mislead someone into drinking from them.

Do not pour waste onto the ground, down a drain, or into any water source.

Air conditioning refrigerants escaping into the air can damage the Earth's atmosphere. Government regulations may require a certified air conditioning service center to recover and recycle used air conditioning refrigerants.

Inquire on the proper way to recycle or dispose of waste from your local environmental or recycling center, or from your John Deere dealer.

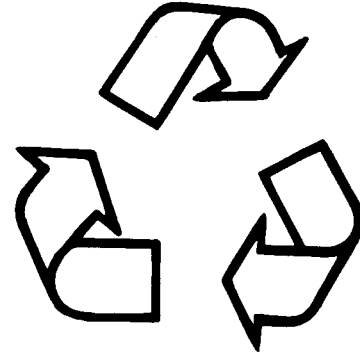

TS1133 -UN-26NOV90

DX,DRAIN -19-03MAR93

Safety Signs

PICTORIAL SAFETY SIGNS

At several important places of this machine safety signs are affixed intended to signify potential danger. The hazard is identified by a pictorial in a warning triangle. An adjacent pictorial provides information how to avoid personal injury. These safety signs, their placement on the machine and a brief explanatory text are shown below.



FX,WBZ

-19-19NOV91

TS231 -19-07OCT88

OPERATOR'S MANUAL

This operator's manual contains important information necessary for safe machine operation. Carefully observe all safety rules to avoid accidents.

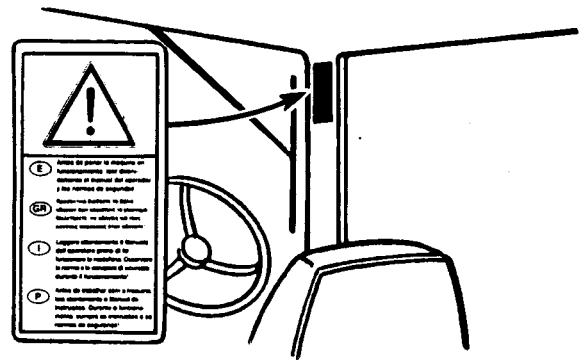

RX,OMLC

-19-03MAR93

RW22599 -UN-09MAR93

ROCKSHAFT REMOTE CONTROL

Stay clear of three-point hitch lift range when operating with remote control.

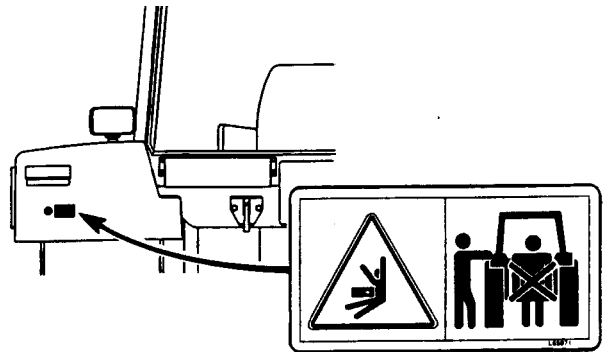

RX,REMOTE,LCR2 -19-03MAR93

RW22605 -UN-09MAR93

RADAR SENSOR (OPTIONAL)

To avoid possible eye damage, do not look directly into face of sensor.

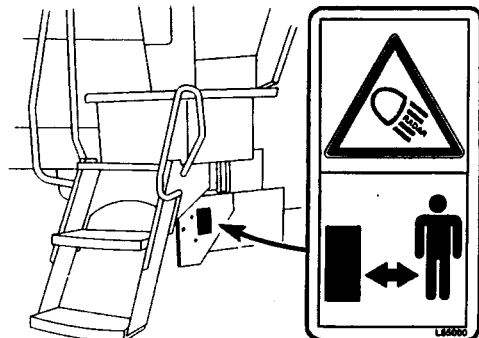

RX,RAD,LC

-19-03MAR93

RW22606 -UN-09MAR93

HYDRAULIC ACCUMULATORS

Hydraulic accumulator contains gas and oil under pressure. For removal and repair, instructions in Technical Manual must be followed.

- A—Seat Accumulator
- B—Transmission Accumulator
- C—Brake Accumulator

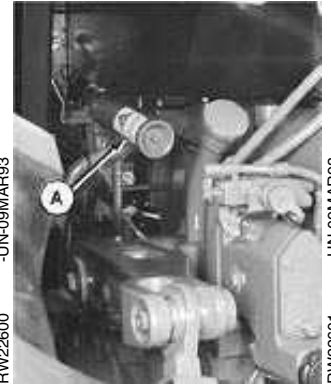

RW22600 -JUN-09MAR93

-JUN-09MAR93 RW22601



RW22602 -JUN-09MAR93



-JUN-09MAR93 RW22603

RX_HYDRACCUM -19-03MAR93

Controls and Instruments

SOUND-GARD® BODY CONTROLS

- A—Left Wiper Switch
- B—Air Conditioning Temperature Control
- C—Blower Switch
- D—Heater Temperature Control
- E—Windshield Washer Button
- F—Right Wiper Switch
- G—Dome Lamp
- H—Dome Lamp Switch
- I—Console Lamp

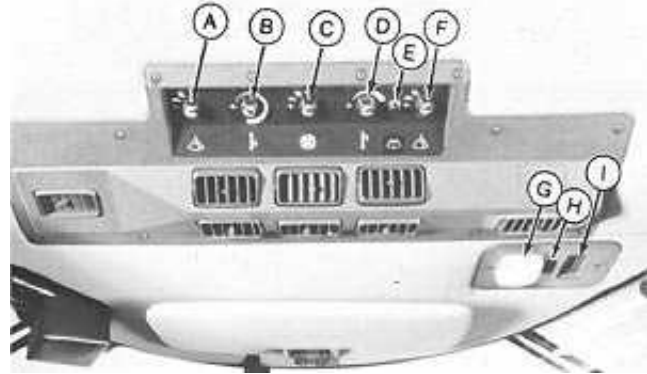

RX,110570,15,1 -19-02JUL91

RW19482 -UN-27JUN91

TRACTOR CONTROLS—FRONT CONSOLE

- A—PTO Lever
- B—Turn Signal Control
- C—Steering Wheel Telescope Release
- D—Hazard Switch
- E—Secondary Brake Lamp
- F—Secondary Brake
- G—MFWD Switch
- H—Starting Aid Button
- I—Light Switch
- J—Key Switch
- K—Horn Button
- L—Foot Throttle
- M—Brake Pedals
- N—Steering Wheel Tilt Release
- O—Differential Lock Pedal
- P—Lighter
- Q—Head Lamp Dimmer Switch
- R—Clutch Pedal

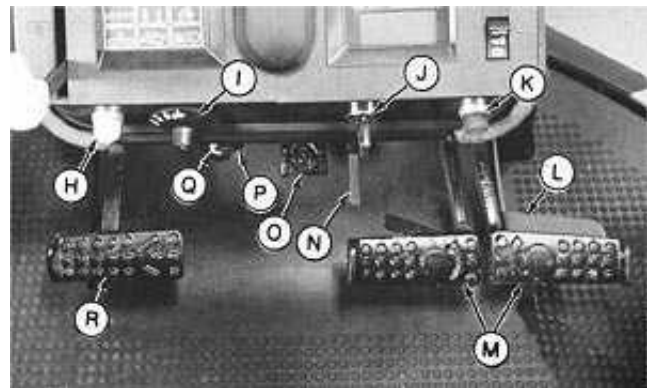
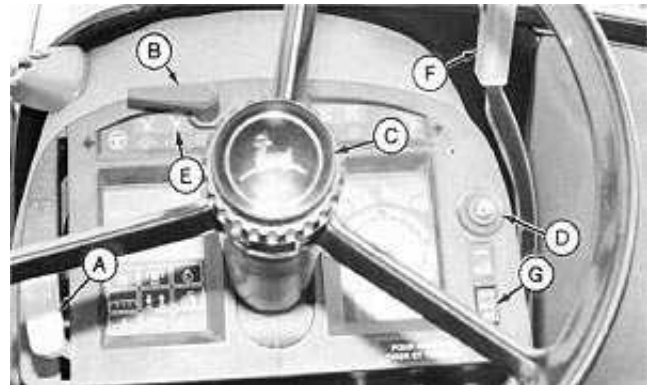

RX,110570,15,0 -19-02JUL91

RW19481 -UN-01JUL91

RW19482 -UN-01JUL91

TRACTOR CONTROLS—SIDE CONSOLE

- A—Remote Hydraulic Levers
- B—Rockshaft Controls
- C—Accessory Electrical Outlet
- D—Rockshaft Depth Stop Knob
- E—Raise/Lower Limit Switch
- F—Rockshaft Control Lever
- G—Hand Throttle
- H—Shift Lever

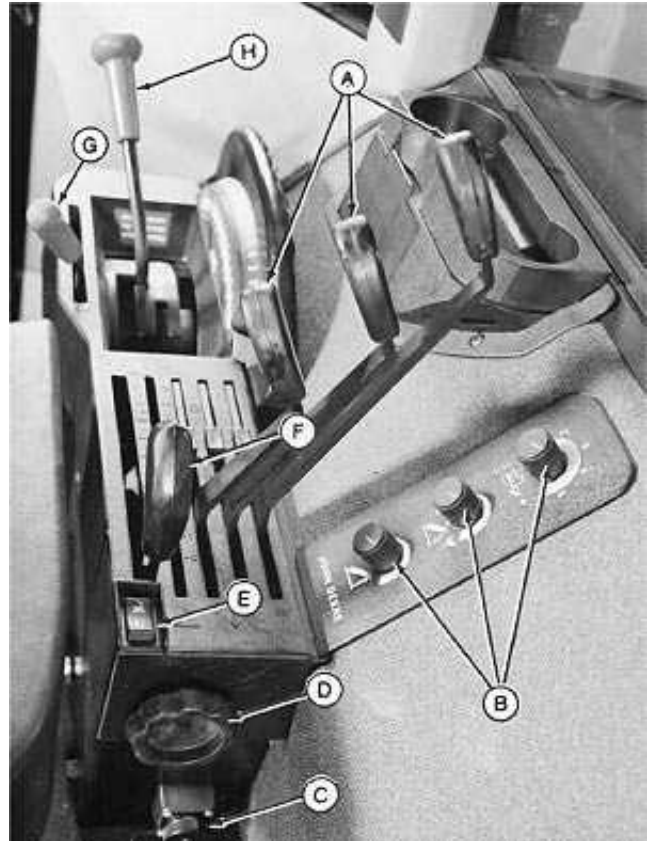

-UN-20JAN93
RW22371

RXLCR,15,2 -19-09DEC92

INTELLITRAK® ELECTRONIC INSTRUMENTATION

The INTELLITRAK system on your tractor offers performance monitoring of the most important functions. The INTELLITRAK system also records diagnostic codes, which are analyzed by your servicing dealer should your tractor require this service.

- A—Warning Indicator Lamps
- B—Tachometer
- C—Performance Monitor

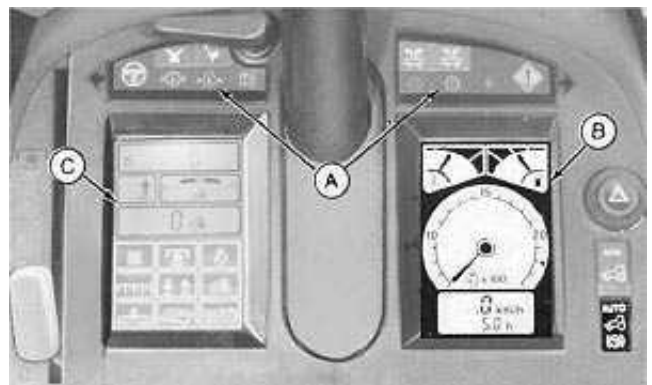

-UN-25OCT89
RW16100

RX,H525 -19-20DEC88

CHECK INSTRUMENTS OFTEN

IMPORTANT: See your John Deere dealer if any instrument malfunctions. Operate tractor only if all instruments work properly.

Check indicator lamps and audible warning signal each time engine is started. All warning indicator lamps (A), "Service Alert" (B), and red "Stop Engine" (C) signals should glow for two seconds when key switch is turned to first position. Audible warning horn should be heard for one second while lamps glow.

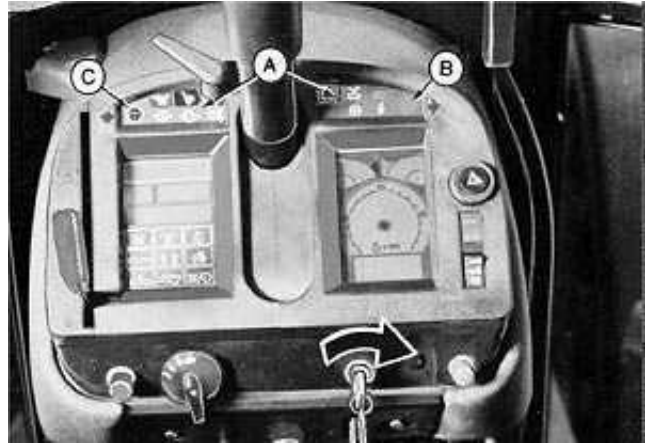

RW19390 -UN-21JUN91

RX,110570,15,3 -19-02JUL91

OBEY "STOP ENGINE" SIGNAL

IMPORTANT: If the "Stop Engine" signal comes on, stop the engine immediately and put transmission in park. Then, determine and correct the cause.

A red "Stop Engine" signal (A) flashes whenever a vital tractor system malfunctions (such as cooling or lubrication). A steady, audible tone from warning horn accompanies this signal.

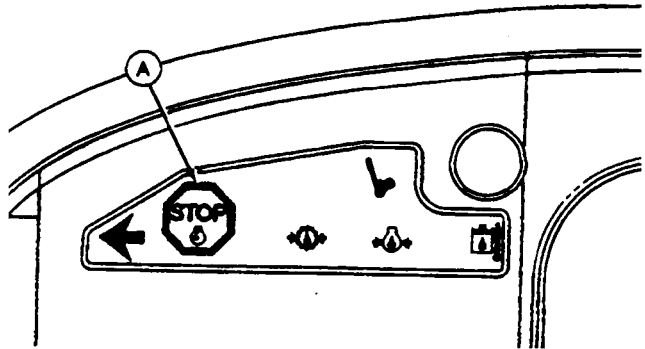

RW15193 -UN-03APR89

RX,H527 -19-02JUL91

OBSERVE "SERVICE ALERT" SIGNAL

An amber "Service Alert" signal (A) flashes when a problem develops which does not require immediate engine shut down. Observe gauges and indicator lamps for possible cause. A maintenance check or a change in tractor operation should be initiated as soon as possible. An audible "beep" alerts the operator to a function that has reached a warning condition.

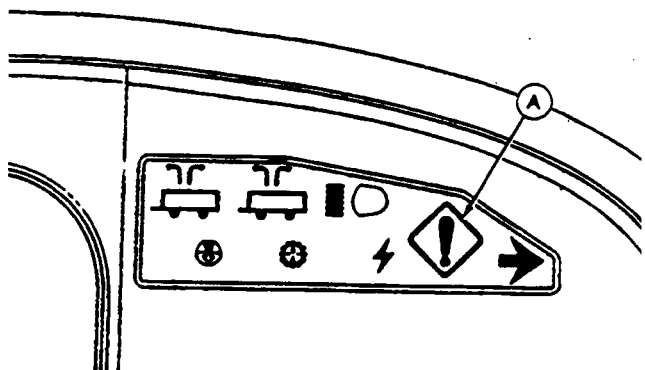

RW15194 -UN-03APR89

RX,H528 -19-14NOV88

CHECK TRANSMISSION OIL PRESSURE INDICATOR

If transmission control pressure or lube pressure falls too low, indicator (A) will glow, "Stop Engine" signal (B) will flash and warning horn will sound. Stop engine and determine cause. If low transmission-hydraulic oil level is not the problem, see your John Deere dealer.

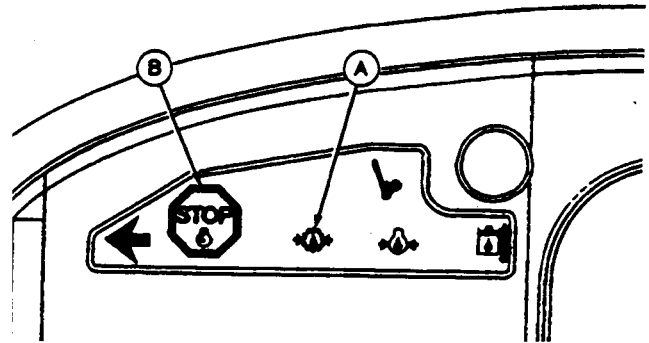

RX,H529 -19-02JUL91

RW15195 -UN-03APR89

CHECK ENGINE OIL PRESSURE INDICATOR

IMPORTANT: NEVER operate engine without sufficient oil pressure—not even for a minute.

If engine oil pressure falls too low, indicator (A) will glow, "Stop Engine" signal (B) will flash, and warning horn will sound. Stop engine immediately and determine the cause. If low oil level is not the problem, see your John Deere dealer.

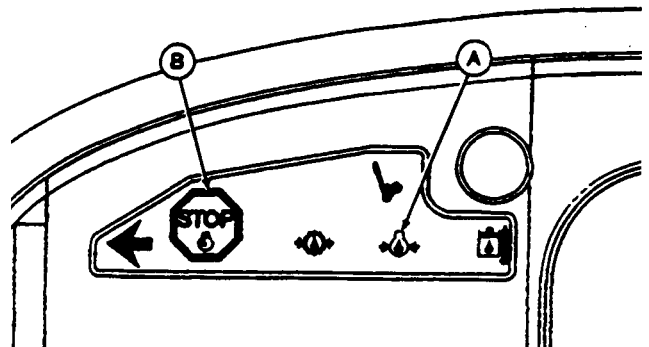

RX,H530 -19-13DEC88

RW15196 -UN-03APR89

CHECK HYDRAULIC OIL TEMPERATURE INDICATOR

If hydraulic oil becomes excessively hot, indicator (A) and "Service Alert" signal will flash and warning horn will beep. Reduce transmission or hydraulic load. Check for low transmission-hydraulic oil level and plugged oil cooler. If the oil temperature continues to rise, red "Stop Engine" signal (B) will flash and horn tone becomes constant. Stop engine and determine cause. If problem is not found, see your John Deere dealer.

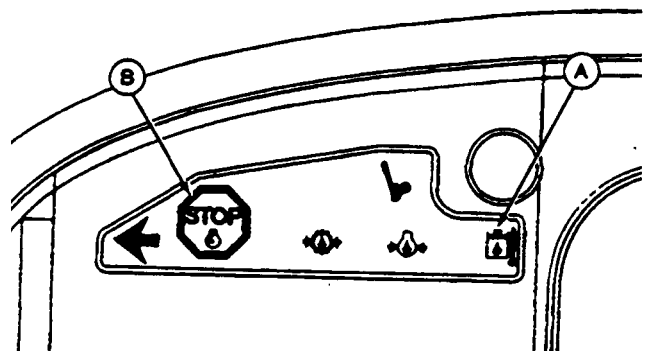

RX,H531 -19-02JUL91

RW15197 -UN-03APR89

CHECK AIR FILTER RESTRICTION INDICATOR

Air filter indicator (A) will glow, "Service Alert" signal (B) flashes, and horn will beep to indicate a restriction to intake air flow through air filter. Service air filter elements as soon as possible. (See Service Air Cleaner in Service section.)

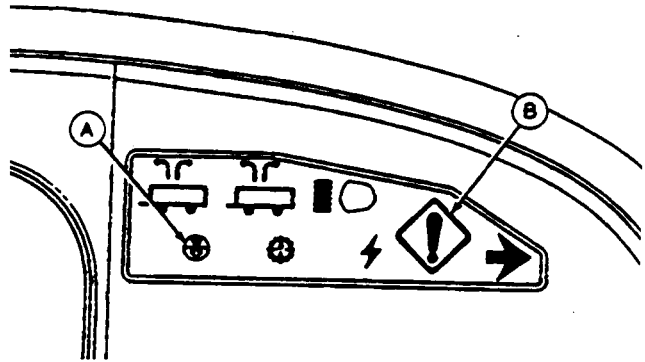

RX,H532 -19-13DEC88

RW15198 -UN-03APR89

CHECK TRANSMISSION FILTER RESTRICTION INDICATOR

Transmission filter indicator (A) will glow, "Service Alert" signal (B) flashes, and horn will beep if transmission filter becomes partially plugged. Upon receiving warning signal, replace transmission filter as soon as possible. (See Lubrication and Maintenance section.) If filter replacement does not solve problem, see your John Deere dealer.

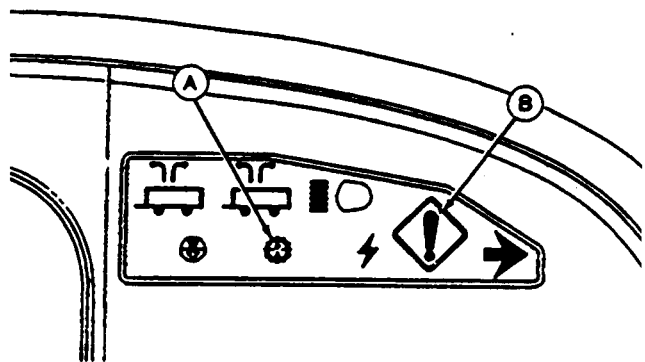

RX,H533 -19-13DEC88

RW15199 -UN-03APR89

CHECK VOLTAGE INDICATOR

If system voltage is too high or too low, or batteries are undercharged, indicator (A) will glow, "Service Alert" signal (B) will flash, and warning horn will beep. (Refer to Electrical System in Troubleshooting section.) If problem is still not found, have your John Deere dealer check charging system.

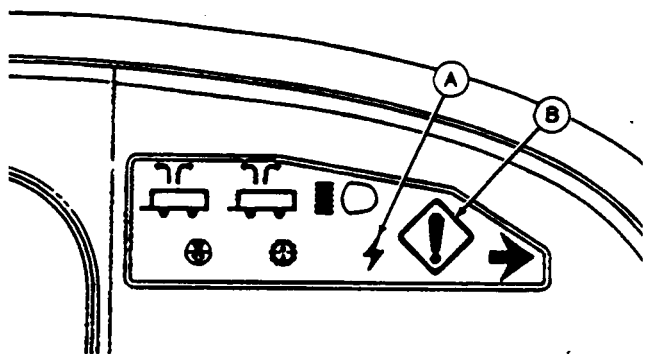

RX,H534 -19-02JUL91

RW15200 -UN-03APR89

IDENTIFYING TACHOMETER FUNCTIONS

- A—Engine Coolant Temperature Gauge
- B—Fuel Gauge
- C—Engine Speed
- D—Rated Speed
- E—Ground Speed
- F—Hourmeter

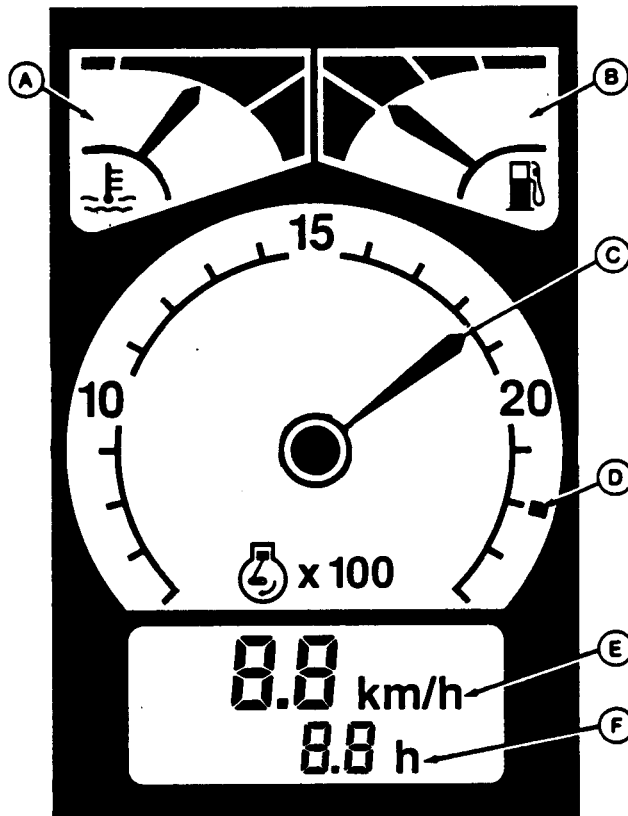

-UN-11NOV89
RW16102

RX,H889 -19-18MAR91

WATCH FUEL LEVEL

There are nine pointer positions displaying fuel level. Stop to refuel before fuel gauge (A) reaches empty mark. When fuel level reaches amber area (B), fuel pump symbol (C) will flash.

Use diesel fuel specified in Fuels, Lubricants, and Coolant section.

Should tractor run out of fuel and not start in several tries, air must be removed from fuel system. (See Removing Air from Fuel Lines in Service section.)

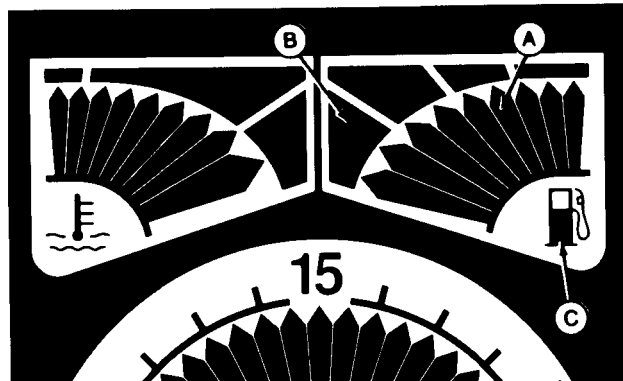

-UN-25OCT89
RW16086

RX,H311 -19-02JUL91

CHECK ENGINE COOLANT-TEMPERATURE GAUGE

Green area (A) of temperature gauge represents normal operating temperature. If pointers on gauge rise to red area (B), coolant-temperature symbol (C) and pointers will flash, "Service Alert" signal will come on, and warning horn will beep.

Check grille screens and radiator for restrictions. Check coolant level when engine cools. Reduce load or shift to a lower gear.

If needles rise further into red area (D), coolant temperature symbol and red "Stop Engine" signal will flash and steady warning horn will beep. Stop engine immediately and determine cause. (See Engine in Troubleshooting section.)

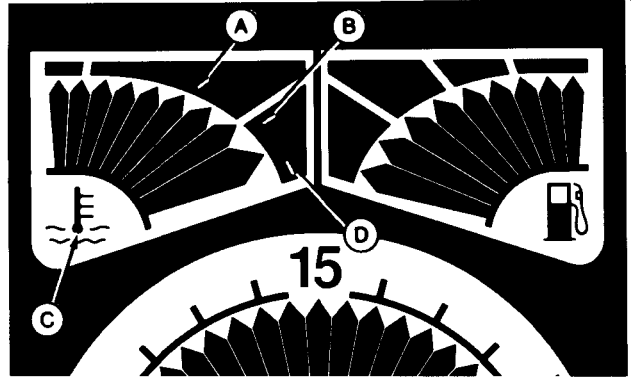

- A—Normal Temperature
- B—Warning Temperature
- C—Coolant-Temperature Symbol
- D—Alarm Temperature

RW16088 -JUN-25OCT89

RX,H312

-19-05NOV90

TACHOMETER FUNCTION DESCRIPTION

Tachometer provides function for fuel level, engine coolant temperature, engine speed, ground speed, and engine hours.

- **ENGINE SPEED**—Each pointer position represents a 50 rpm change (tachometer is divided by increments of 100, but pointer also stops midway between marked increments). Engine speed (A) is displayed from 500—2500 rpm.
- **RATED SPEED**—A symbol (B) on engine speed gauge shows rated engine speed (2200 rpm). When PTO is engaged, symbol indicates engine rpm necessary to achieve rated PTO speed. If PTO is not engaged, symbol indicates rated engine rpm.

NOTE: PTO speed is displayed on performance monitor.

- **GROUND SPEED**—Readings (C) are to nearest tenth. Below 0.8 kilometer per hour (0.5 mile per hour), display reads zero.

An optional radar sensor for “true” ground speed is available with your tractor.

- **HOURMETER**—Engine hours (D) are in hours and tenths up to 9999.9 hours. After this point, display starts over again. Engine hours are accumulated only when engine is running. Engine hours are independent of engine speed.

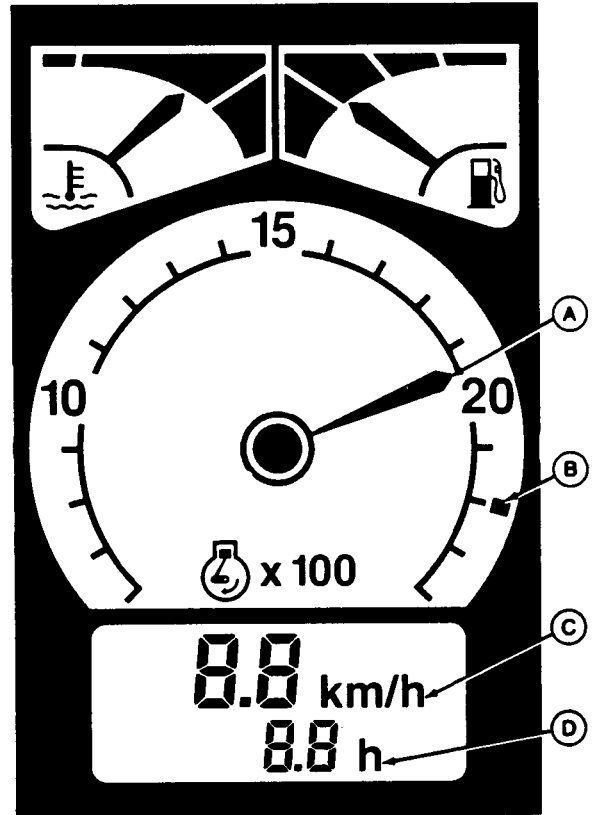

- A—Engine Speed
- B—Rated Speed
- C—Ground Speed
- D—Hourmeter

RW16103 -UN-25OCT89

IDENTIFYING PERFORMANCE MONITOR FUNCTIONS

- A—Upper Digital Display
- B—Status/Adjust Arrows
- C—% Slip Bar Graph
- D—Lower Digital Display
- E—Area Accumulated
- F—PTO Speed
- G—Engine Speed
- H—Distance Traveled
- I—Adjust Function/
Implement Status
- J—% Slip
- K—Width of Implement
- L—Service Hours
- M—Area Per Hour

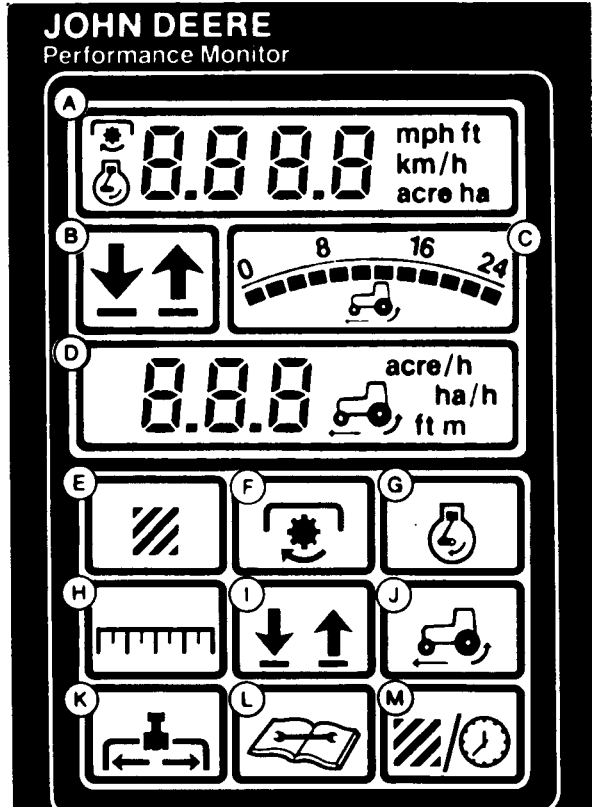

RX,H315

-19-25OCT88

RW16089 -UN-25OCT89

PERFORMANCE MONITOR FUNCTION DESCRIPTION

Performance monitor has capability of displaying digital values for ground speed, productivity, area covered, wheel slip, PTO speed, engine speed, distance, and hours since last service. Monitor also has a bar graph to continuously display slip, with an excessive slip alarm.

Radar sensor is required for wheel slip only. Without radar productivity, area covered and distance values are only estimates.

Touch switch you want to display. Press same switch again to access set modes to preset or change values for area, distance, % slip alarm, implement width, or service hour interval. (See Adjust Touch Switch.)

Display will return to normal operation after releasing switch for 5 seconds.

RX,H699

-19-01NOV90

This as a preview PDF file from best-manuals.com



Download full PDF manual at best-manuals.com