

# SERVICE MANUAL

## **E55Bx Tier 3** Compact Hydraulic Excavator

Part number S5HS0014E01  
English  
April 2014



# HYDRAULIC EXCAVATOR

**SHOP  
MANUAL**

**model**

**E55Bx**

## INDEX

1	SPECIFICATIONS SECTION
2	MAINTENANCE SECTION
3	SYSTEM SECTION
4	DISASSEMBLY SECTION
5	TROUBLESHOOTING
6	ENGINE SECTION

SPECIFICATIONS

MAINTENANCE

SYSTEM

DISASSEMBLING

TROUBLESHOOTING

E/G

OPT.

---

## GENERAL SAFETY INFORMATION

---



**Do not operate or perform any maintenance on this machine until all instructions found in the OPERATOR'S MANUAL and this MANUAL have been thoroughly read and understood.**

**Improper operation or maintenance of this machine may cause accidents and could result in serious injury or death.**

**Always keep the manual in storage.**

**If it is missing or damaged, place an order with an authorized our Distributor for a replacement.**

**If you have any questions, please consult an authorized our Distributor.**

---

- (1) Most accidents, which occur during operation, are due to neglect of precautionary measures and safety rules. Sufficient care should be taken to avoid these accidents. Erroneous operation, lubrication or maintenance services are very dangerous and may cause injury or death of personnel. Therefore all precautionary measures, NOTES, DANGERS, WARNINGS and CAUTIONS contained in the manual and on the machine should be read and understood by all personnel before starting any work with or on the machine.
- (2) Operation, inspection, and maintenance should be carefully carried out, and safety must be given the first priority. Messages of safety are indicated with marks. The safety information contained in the manual is intended only to supplement safety codes, insurance requirements, local laws, rules and regulations.
- (3) Messages of safety appear in the manual and on the machine : All messages of safety are identified by either word of "DANGER", "WARNING" and "CAUTION".

- 1) **DANGER-** Indicates an imminently hazardous situation which, if not avoided, will result in death or serious injury and is represented as follows:



- 2) **WARNING-** Indicates a potentially hazardous situation which, if not avoided, could result in death or serious injury and is represented as follows:



- 3) **CAUTION-** Indicates a potentially hazardous situation which, if not avoided, may result in minor or moderate injury. It may also be used to alert against possible damage to the machine and its components and is represented as follows:



- (4) It is very difficult to forecast every danger that may occur during operation. However, safety can be ensured by fully understanding proper operating procedures for this machine according to methods recommended by Manufacturer.
- (5) While operating the machine, be sure to perform work with great care, so as not to damage the machine, or allow accidents to occur.
- (6) Continue studying the manual until all Safety, Operation and Maintenance procedures are completely understood by all persons working with the machine.

---

## SAFETY PRECAUTIONS

---



The proper and safe lubrication and maintenance for this machine, recommended by Manufacturer, are outlined in the OPERATOR'S MANUAL for the machine.

**Improper performance of lubrication or maintenance procedures are dangerous and could result in injury or death. Read and understand the MANUAL before performing any lubrication or maintenance.**

The serviceman or mechanic may be unfamiliar with many of the systems on this machine. This makes it important to use caution when performing service work. A knowledge of the system and or components is important before the removal or disassembly of any component.

Because of the size of some of the machine components, the serviceman or mechanic should check the weights noted in this manual. Use proper lifting procedures when removing any components. Weight of components table is shown in the section ; SPECIFICATIONS.

The following is a list of basic precautions that must always be observed.

- (1) Read and understand all Warning plates and decal on the machine before Operating, Maintaining or Repairing this machine.
- (2) Always wear protective glasses and protective shoes when working around machines. In particular, wear protective glasses when using hammers, punches or drifts on any part of the machine or attachments. Use welders gloves, hood/goggles, apron and the protective clothing appropriate to the welding job being performed. Do not wear loose fitting or torn clothing. Remove all rings from fingers, loose jewelry, confine long hair and loose clothing before working on this machinery.
- (3) Disconnect the battery and hang a "Do Not Operate" tag in the Operators Compartment. Remove ignition keys.
- (4) If possible, make all repairs with the machine parked on a firm level surface. Block the machine so it does not roll while working on or under the machine. Hang a "Do Not Operate" tag in the Operators Compartment.
- (5) Do not work on any machine that is supported only by lift, jacks or a hoist. Always use blocks or jack

stands, capable of supporting the machine, before performing any disassembly.



**Do not operate this machine unless you have read and understand the instructions in the OPERATOR'S MANUAL. Improper machine operation is dangerous and could result in injury or death.**

- 
- (6) Relieve all pressure in air, oil or water systems before any lines, fittings or related items are disconnected or removed. Always make sure all raised components are blocked correctly and be alert for possible pressure when disconnecting any device from a system that utilizes pressure.
  - (7) Lower the bucket, dozer, or other attachments to the ground before performing any work on the machine. If this cannot be done, make sure the bucket, dozer, ripper or other attachment is blocked correctly to prevent it from dropping unexpectedly.
  - (8) Use steps and grab handles when mounting or dismounting a machine. Clean any mud or debris from steps, walkways or work platforms before using. Always face to the machine when using steps, ladders and walkways. When it is not possible to use the designed access system, provide ladders, scaffolds, or work platforms to perform safe repair operations.
  - (9) To avoid back injury, use a hoist when lifting components which weigh 20kg (45lbs) or more. Make sure all chains, hooks, slings, etc., are in good condition and are the correct capacity. Be sure hooks are positioned correctly. Lifting eyes are not to be side loaded during a lifting operation.
  - (10) To avoid burns, be alert for hot parts on machines which have just been stopped and hot fluids in lines, tubes and compartments.
  - (11) Be careful when removing cover plates. Gradually back off the last two capscrews or nuts located at opposite ends of the cover or device and carefully pry cover loose to relieve any spring or other pressure, before removing the last two capscrews or nuts completely.
  - (12) Be careful when removing filler caps, breathers and plugs on the machine. Hold a rag over the cap or plug to prevent being sprayed or splashed by liquids under pressure. The danger is even greater if the machine has just been stopped because fluids can be hot.

- 
- (13) Always use the proper tools that are in good condition and that are suited for the job at hand. Be sure you understand how to use them before performing any service work.
- (14) Reinstall all fasteners with the same part number. Do not use a lesser quality fastener if replacements are necessary.
- (15) Repairs which require welding should be performed only with the benefit of the appropriate reference information and by personnel adequately trained and knowledgeable in welding procedures. Determine type of metal being welded and select correct welding procedure and electrodes, rods or wire to provide a weld metal strength equivalent at least to that of the parent metal. Make sure to disconnect battery before any welding procedures are attempted.
- (16) Do not damage wiring during removal operations. Reinstall the wiring so it is not damaged nor will be damaged in operation of the machine by contacting sharp corners, or by rubbing against some object or hot surface. Do not connect wiring to a line containing fluid.
- (17) Be sure all protective devices including guards and shields are properly installed and functioning correctly before starting a repair. If a guard or shield must be removed to perform the repair work, use extra caution and replace the guard or shield after repair is completed.
- (18) The maintenance and repair work while holding the bucket raised is dangerous due to the possibility of a falling attachment. Don't fail to lower the attachment and place the bucket to the ground before starting the work.
- (19) Loose or damaged fuel, lubricant and hydraulic lines, tubes and hoses can cause fires. Do not bend or strike high pressure lines or install ones which have been bent or damaged. Inspect lines, tubes and hoses carefully. Do not check for leaks with your hands. Very small (pinhole) leaks can result in a high velocity oil stream that will be invisible close to the hose. This oil can penetrate the skin and cause personal injury. Use card-board or paper to locate pinhole leaks.
- (20) Tighten connections to the correct torque. Make sure that all heat shields, clamps and guards are installed correctly to avoid excessive heat, vibration or rubbing against other parts during operation. Shields that protect against oil spray onto hot exhaust components in event of a line, tube or seal failure must be installed correctly.
- (21) Do not operate a machine if any rotating part is damaged or contacts any other part during operation. Any high speed rotating component that has been damaged or altered should be checked for balance before reusing.
- (22) Be careful when servicing or separating the tracks (crawlers). Chips can fly when removing or installing a track (crawlers) pin. Wear safety glasses and long sleeve protective clothing. Tracks (crawlers) can unroll very quickly when separated. Keep away from front and rear of machine. The machine can move unexpectedly when both tracks (crawlers) are disengaged from the sprockets. Block the machine to prevent it from moving.

**INDEX**

Book Code No. Distribution Year–Month			Title	Index No.
S5PA0105E01 2013-12		<b>SPECIFICATIONS</b>	OUTLINE	1
S5PS0214E01 2013-12			SPECIFICATIONS	2
S5PS0314E01 2013-12			ATTACHMENT DIMENSIONS	3
S5PS1113E01 2013-12		<b>MAINTENANCE</b>	TOOLS	11
S5PS1214E01 2013-12			STANDARD MAINTENANCE TIME SCHEDULE	12
S5PS1314E01 2013-12			MAINTENANCE STANDARD AND TEST PROCEDURE	13
S5PS2114E01 2013-12		<b>SYSTEM</b>	MECHATRO CONTROL (OPT.)	21
S5PS2214E01 2013-12			HYDRAULIC SYSTEM	22
S5PS2314E01 2013-12			ELECTRIC SYSTEM	23
S5PS2414E01 2013-12			COMPONENTS SYSTEM	24
S5PS2514E01 2013-12			AIR-CONDITIONER SYSTEM	25
—				
S5PA3105E01 2013-12		<b>DISASSEMBLING</b>	DISASSEMBLING & ASSEMBLING	31
S5PS3214E01 2013-12			ATTACHMENT	32
S5PS3314E01 2013-12			UPPER STRUCTURE	33
S5PS3413E01 2013-12			TRAVEL SYSTEM	34
—				
S5PS4213E01 2013-12		<b>TROUBLESHOOTING</b>	HYDRAULIC SYSTEM	42
S5PS4314E01 2013-12			ELECTRIC SYSTEM	43
S5PW4431E02 2013-12			ENGINE	44
S5PS4613E01 2013-12			BY ERROR CODES	46
—				
S5PS5114E01 2013-12		<b>E/G</b>	ENGINE	51
—				
PS03-05001~			APPLICABLE MACHINES	

33

25

1

42

34

2

51

43

11

3

44

12

21

13

46

22

31

23

32

24

---

## NOTE:

This Manual is prepared as a technical material in which the information necessary for the maintenance and repairing services of our hydraulic excavators are collected, and is categorized into 7 Chapters, Specification, Maintenance, System, Disassembly, Troubleshooting, Engine, and Installation Procedures for Optional Attachment.

- The Chapter "Specification" describes the specifications for entire machine and material, which are instructive for replacement and repairing of attachments.
- The Chapter "Maintenance" describes the material, which is helpful for maintenance service and adjustments for entire machine.
- The Chapter "System" describes the operating system like hydraulic system, electric system, components, and so on.
- The Chapter "Disassembly" describes the removal and installing of assembly mounted on the upper structure and undercarriage, and the assembling and disassembling of the associated hydraulic equipment.
- The Chapter "Troubleshooting" describes how to find the fault equipment.
- The Chapter "Engine" describes the engines making use of the "Maintenance Manual" provided by the suppliers.
- The Chapter "Installation Procedures for Optional Attachment" describes the supplements added on request as required.

This Manual may be properly revised due to the improvement of products, modification of specifications, etc. And there are cases where the system on actual machine and a part of the contents of this manual may differ due to the variations of specification by countries. For the section in which the description is hardly understood, contact our distributor.

The number is assigned to every part handled in this Manual on account of the description, but the parts, which cannot be supplied as service parts are contained. Therefore, the order must be placed with respective formal number with due confirmation on the Parts Manual for applicable machine.

# 1. OUTLINE

## TABLE OF CONTENTS

1.1	GENERAL PRECAUTIONS FOR REPAIRS .....	1-3
1.1.1	PREPARATION BEFORE DISASSEMBLING .....	1-3
1.1.2	SAFETY IN DISASSEMBLING AND ASSEMBLING .....	1-3
1.1.3	DISASSEMBLING AND ASSEMBLING HYDRAULIC EQUIPMENT .....	1-4
1.1.4	ELECTRICAL EQUIPMENT .....	1-6
1.1.5	HYDRAULIC PARTS .....	1-7
1.1.6	WELDING REPAIR .....	1-7
1.1.7	ENVIRONMENTAL MEASURE .....	1-7
1.2	INTERNATIONAL UNIT CONVERSION SYSTEM (Based on MARKS' STANDARD HANDBOOK FOR MECHANICAL ENGINEERS) .....	1-8



---

## 1.1 GENERAL PRECAUTIONS FOR REPAIRS

### 1.1.1 PREPARATION BEFORE DISASSEMBLING



#### (1) Understanding operating procedure

Read OPERATOR'S MANUAL carefully to understand the operating procedure.

#### (2) Cleaning machines

Remove soil, mud, and dust from the machine before carrying it into the service shop to prevent loss of work efficiency, damage of parts, and difficulty in rust prevention and dust protection while reassembling.

#### (3) Inspecting machines

Identify the parts to be disassembled before starting work, determine the disassembling procedure by yourself considering the workshop situations etc., and request procurement of necessary parts in advance.

#### (4) Recording

Record the following items for communication and prevention of recurring malfunction.

1. Inspection date and place.
2. Model name, applicable machine number, and hour meter read.
3. Trouble condition, place and cause.
4. Visible oil leakage, water leakage and damage.
5. Clogging of filters, oil level, oil quality, oil contamination and loosening of connections.
6. Result of consideration if any problem exists based on the operation rate per month calculated from hour meter indication after the last inspection date.

#### (5) Arrangement and cleaning in service shop

1. Tools required for repair work.
2. Prepare space to place the disassembled parts.
3. Prepare oil containers for draining oil etc.

### 1.1.2 SAFETY IN DISASSEMBLING AND ASSEMBLING



- (1) Wear appropriate clothes with long sleeves, safety shoes, safety helmet and protective glasses.
- (2) Suspend warning tag "DO NOT OPERATE" from the doorknob or the operating lever, and have a preliminary meeting before starting work.
- (3) Stop the engine before starting inspection and maintenance to prevent the operator being caught in machine.
- (4) Identify the location of a first-aid kit and a fire extinguisher, and also where to make contact in a state of emergency.
- (5) Choose a hard, level and safe place, and place the attachment on the ground securely.
- (6) Use a lifter such as a crane to remove heavy parts (20 kg [45 lbs] or more) from the machine.
- (7) Use proper tools, and replace or repair defective tools.
- (8) Support the machine and attachment with supports or blocks if the work is performed in the lifted condition.

## 1. OUTLINE

---

### 1.1.3 DISASSEMBLING AND ASSEMBLING HYDRAULIC EQUIPMENT



#### (1) Removing hydraulic equipment

1. Before disconnecting pipes, release the hydraulic pressure of the system, or open the return side cover and take out the filter.
2. Carefully drain oil of the removed pipes into a containers without spilling on the floor.
3. Apply plugs or caps on the pipe ends to avoid oil spillage and dust intrusion.
4. Clean off the external surface of the equipment before disassembling, and drain hydraulic and gear oil before placing it on the workbench.

#### (2) Disassembling hydraulic equipment

1. Do not disassemble, reassemble or modify the hydraulic equipment without the permission of the manufacturer, who is not responsible for the performance and function of the product after modification.
2. When disassembling and reassembling for unavoidable reason, refer the work to qualified personnel who have the specific knowledge or completed the parts service training.
3. Provide matching marks to facilitate reassembling work.
4. Before starting the work, read the manual of disassembling procedure, if it is provided, and decide whether the work can be performed by yourself.
5. Use the special jig and tools without fail if they are specified.
6. If it is hard to remove a part according to the procedure, do not try it by force but investigate the cause.
7. Place the removed parts in order and attach tags to facilitate the reassembling.
8. Note the location and quantity of parts commonly applied to multiple locations.

#### (3) Inspecting parts

1. Ensure that the disassembled parts are free from seizure, interference and uneven contact.
2. Measure and record wear condition of parts and clearance.
3. If the problem is found in a part, repair or replace it with a new one.

#### (4) Reassembling hydraulic equipment

1. Turn ON the ventilation fan or open windows to maintain good ventilation prior to starting the cleaning of parts.
2. Perform rough and finish cleaning before assembling.
3. Remove washing oil by air and apply clean hydraulic or gear oil for assembling.
4. Always replace the removed O-rings, backup rings and oil seals with new ones by applying grease in advance.
5. Remove dirt and moisture from and perform degreasing on the surface where liquid gasket to be applied.
6. Remove rust preventive agent from the new parts before use.
7. Fit bearings, bushings and oil seals using special jigs.
8. Assemble the parts utilizing matching marks.
9. Ensure all the parts are completely assembled after the work.

**(5) Installing hydraulic equipment**

1. Ensure hydraulic oil and lubricant are properly supplied.
2. Perform air bleeding when :
  - a. Hydraulic oil changed
  - b. Parts of suction side piping replaced
  - c. Hydraulic pump installed
  - d. Slewing motor installed
  - e. Travel motor installed
  - f. Hydraulic cylinder installed
3. Perform air bleeding of the hydraulic pump and slewing motor after loosening the upper drain plug, starting the engine and keep it in low idle condition.  
Complete the air bleeding when seeping of hydraulic oil is recognized, and tightly plug.
4. Perform air bleeding of the travel motor and the hydraulic cylinders by running the engine for more than 5 minutes at low speed without load.
5. Perform air bleeding of pilot line by performing a series of digging, slewing and travel.
6. Check hydraulic oil level after placing the attachment to the oil check position, and replenish oil if necessary.

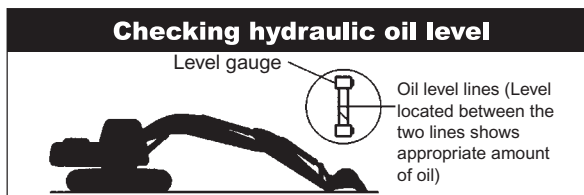
**WARNING**

Operation of the hydraulic equipment without filling hydraulic oil or lubricant or without performing air bleeding will result in damage to the equipment.

**WARNING**

Do not allow the hydraulic cylinder to bottom on the stroke end just after the maintenance.

## 1. OUTLINE

---

### 1.1.4 ELECTRICAL EQUIPMENT

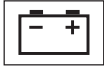

- (1) Do not disassemble electrical equipment.
- (2) Handle it carefully not to drop and give a shock.
- (3) Turn the key OFF prior to connecting and disconnecting work.
- (4) Disconnect the connector by holding it and pressing the lock. Do not pull the wire to apply force to the caulking portion.
- (5) Connect the connector and ensure it is completely locked.
- (6) Turn the key OFF prior to touching the terminal of starter or generator.
- (7) Remove the ground (earth) terminal of battery when handling tools around the battery or its relay.
- (8) Do not splash water on the electrical equipment and connectors during machine washing.
- (9) Check for moisture adhesion inside the waterproof connector after pulling it out, since it is hard to remove moisture from the connector.  
If moisture adhesion is found, dry it completely before the connection.

---

#### **WARNING**

Battery electrolyte is hazardous.

Battery electrolyte is dilute sulfuric acid. Exposure of skin or eyes to this liquid will cause burning or loss of eyesight.

If the exposure occurs, take the following emergency measures and seek the advice of a medical specialist.

-When skin exposed :

Wash with water and soap sufficiently.

-When eyes exposed :

Immediately wash away with city water continuously for more than 10 minutes.

-When a large amount of the liquid flows out :

Neutralize with sodium bicarbonate or wash away with city water.

-When swallowed :

Drink a large amount of milk or water.

-When clothes exposed:

Immediately undress and wash.

---

### 1.1.5 HYDRAULIC PARTS



#### (1) O-ring

- Ensure O-rings have elasticity and are not damaged before use.
- Use the appropriate O-rings. O-rings are made of various kinds of materials having different hardness to apply to a variety of parts, such as the part for moving or fixed portion, subjected to high pressure, and exposed to corrosive fluid, even if the size is same.
- Fit the O-rings without distortion and bend.
- Always handle floating seals as a pair.

#### (2) Flexible hose (F hose)

- Use the appropriate parts. Different parts are used depending on the working pressure even the size of fitting and the total length of the hose is same.
- Tighten the fitting at the specified torque.  
Ensure no kink, tension, interference nor oil leakage is recognized.

### 1.1.6 WELDING REPAIR

- (1) Refer repair welding to qualified personnel according to the appropriate procedure.
- (2) Disconnect the ground (earth) cable of the battery before starting the repair.  
Failure to do so will cause damage to the electrical equipment.
- (3) Move away the articles in advance that may cause fire if exposed to sparks.
- (4) Before starting the repair of the attachment, do not fail to cover the plated surface of the piston rod with flameproof sheet to prevent it from being exposed to sparks.

### 1.1.7 ENVIRONMENTAL MEASURE

- (1) Run the engine at the place that is sufficiently ventilated.
- (2) Industrial waste disposal  
Dispose of the following parts according to the relevant regulations :  
Waste oil and waste container  
Battery
- (3) Precautions for handling hydraulic oil  
Exposure of eyes to hydraulic oil will cause inflammation. Wear protective glasses before handling to avoid an accident. If an eye is exposed to the oil, take the following emergency measures :  
-When an eye exposed :  
Immediately wash away with city water sufficiently till stimulative feeling vanishes.  
-When swallowed :  
Do not let vomit, and receive medical treatment immediately.  
-When skin exposed:  
Wash with water and soap sufficiently.
- (4) Others  
Use replacement parts and lubricants authorized as the manufacturer's genuine parts.

# 1. OUTLINE

## 1.2 INTERNATIONAL UNIT CONVERSION SYSTEM (Based on MARKS' STANDARD HANDBOOK FOR MECHANICAL ENGINEERS)

### Introduction

Although this manual includes International System of Unit and Foot-Pound System of Units, if you need SI unit, refer to the following international system of units.

Given hereinafter is an excerpt of the units that are related to this manual.

#### 1. Etymology of SI Unites

French: Le Systeme International d' Unites

English: International System of Units

#### 2. Construction of SI Unit System

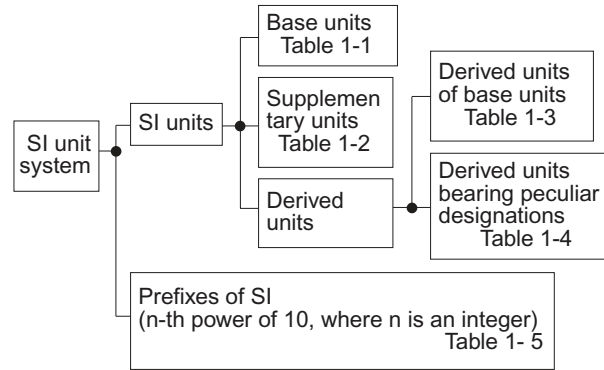

#### (1) Base units

Table 1-1

QUANTITY	UNIT	SYMBOL
Length	meter	m
Mass	kilogram	kg
Time	second	s
Electric current	ampere	A
Thermodynamic temperature	kelvin	K
Amount of substance	mol	mol
Luminous intensity	candela	cd

#### (2) Supplementary units

Table 1-2

QUANTITY	UNIT	SYMBOL
Plane angle	radian	rad
Solid angle	steradian	sr

#### (3) Derived Units

Table 1-3

QUANTITY	UNIT	SYMBOL
Area	square meter	m <sup>2</sup>
Volume	cubic meter	m <sup>3</sup>
Velocity	meter per second	m/s
Acceleration	meter per second squared	m/s <sup>2</sup>
Density	kilogram per cubic meter	kg/m <sup>3</sup>

#### (4) Derived Units bearing Peculiar Designations

Table 1-4

QUANTITY	UNIT	SYMBOL	FORMULA
Frequency	hertz	Hz	1/s
Force	newton	N	kg • m/s <sup>2</sup>
Pressure and Stress	pascal	Pa	N/m <sup>2</sup>
Energy, Work and Quantity of heat	joule	J	N•m
Power	watt	W	J/s
Quantity of electricity	coulomb	C	A•s
Electric potential difference, Voltage, and Electromotive force	volt	V	W/A
Quantity of static electricity and Electric capacitance	farad	F	C/V
Electric resistance	ohm	Ω	V/A
Celcius temperature	celcius degree or degree	°C	(t+273.15)K
Illuminance	lux	lx	l m/m <sup>2</sup>

## (5) Prefixes of SI

Table 1-5

PREFIX	SYMBOL	MULTIPLICATION FACTORS
giga	G	$10^9$
mega	M	$10^6$
kilo	k	$10^3$
hecto	h	$10^2$
deca	da	10
deci	d	$10^{-1}$
centi	c	$10^{-2}$
milli	m	$10^{-3}$
micro	$\mu$	$10^{-6}$
nano	n	$10^{-9}$
pico	p	$10^{-12}$

## (6) Unit Conversion

Table 1-6

QUANTITY	Gravitational	SI	CONVERSION FACTOR
Mass	kgf	kg	
Force	kgf	N	1 kgf=9.807 N
Torque	kgf•m	N•m	kgf•m=9.807 N•m
Pressure	kgf/cm <sup>2</sup>	MPa	1 kgf/cm <sup>2</sup> =0.09807 MPa
Motive Power	PS	kW	1 PS=0.7355 kW
Revolution	rpm	min <sup>-1</sup>	r/min *1

\*1 Units that are allowed to use.



## 1. OUTLINE

---

## 2. SPECIFICATIONS

### TABLE OF CONTENTS

2.1	COMPONENTS NAME .....	2-3
2.2	MACHINE DIMENSIONS .....	2-4
2.3	SPECIFICATIONS AND PERFORMANCE .....	2-5
2.4	MACHINE & COMPONENTS MASS (DRY) .....	2-7
2.5	TRANSPORTATION .....	2-9
2.6	TYPE OF CRAWLER SHOES .....	2-12
2.7	TYPE OF BUCKET .....	2-13
2.8	ENGINE SPECIFICATIONS .....	2-14
2.8.1	SPECIFICATIONS .....	2-14
2.8.2	ENGINE PERFORMANCE CURVE .....	2-15

---

2.1 COMPONENTS NAME

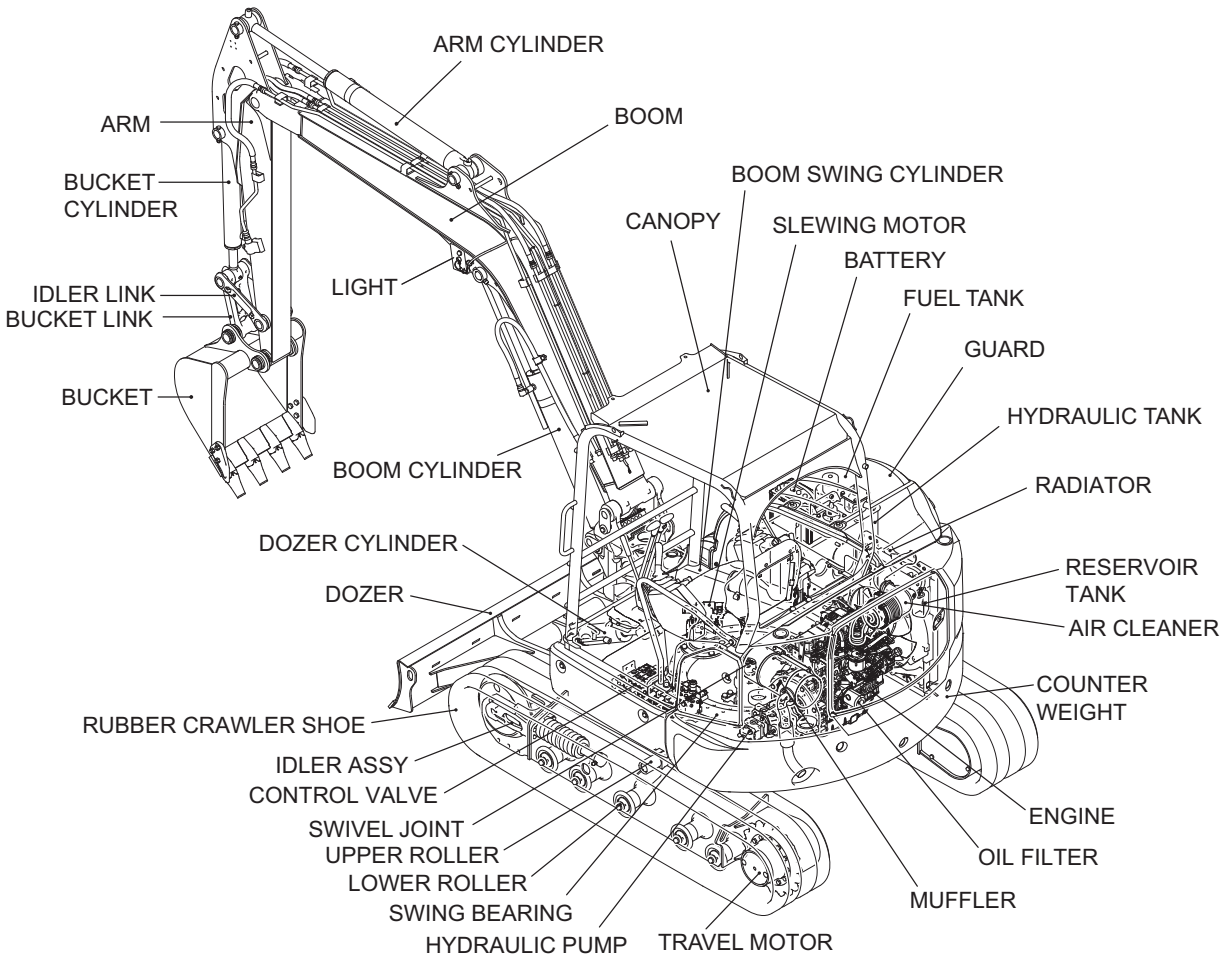

2

## 2. SPECIFICATIONS

### 2.2 MACHINE DIMENSIONS

#### (1) E55Bx (CANOPY)

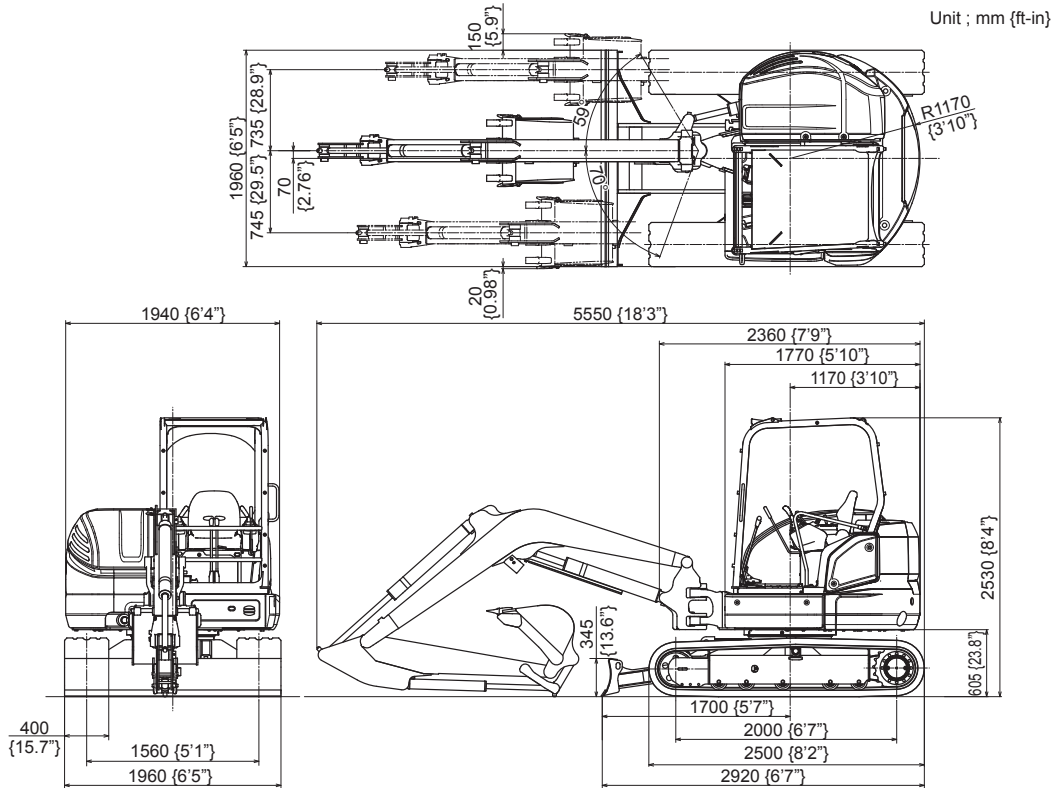

#### (2) E55Bx (CAB)

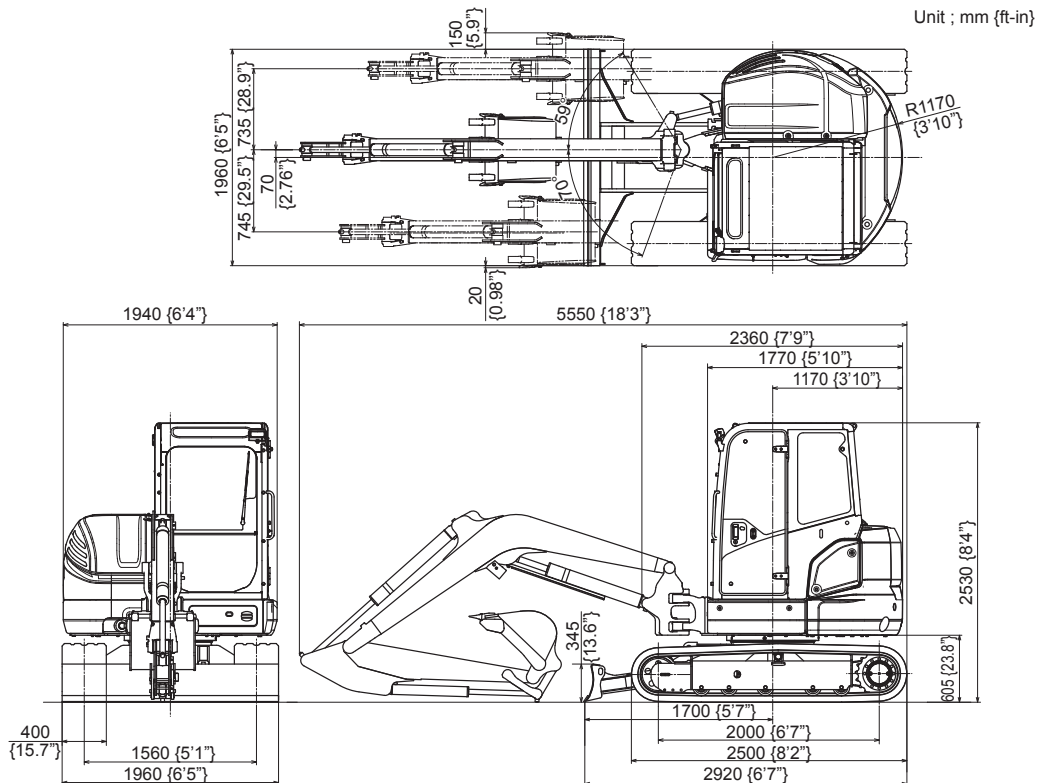

## 2.3 SPECIFICATIONS AND PERFORMANCE

### SPEED AND GRADEABILITY

Model		E55Bx			
Applicable Machines		PS03-05001~			
Shoe Type		Rubber shoe		Iron shoe (OPT)	
Swing Speed	min <sup>-1</sup> {rpm}	8.8 {8.8}			
Travel Speed	km/h (mph)	Low (1st)	High (2nd)	Low (1st)	High (2nd)
		2.1 (1.3)	4.0 (2.5)	2.1 (1.3)	3.7 (2.3)
Gradeability	% (degree)	58(30)			

2

### ENGINE

Model (YANMAR)		4TNV88-B			
Type		Water-cooled, 4-cycle 4cylinder direct injection type diesel engine			
Number of cylinders-Bore X Stroke		4 - 88 dia. mm X 90 mm (3.46 in X 3.54 in)			
Total Displacement	L	2.189 (134 cu-in)			
Output Rating	kW/min <sup>-1</sup> {PS/rpm}	28.3/2,400 {38.5/2,400}			
Maximum Torque	N-m/min <sup>-1</sup> (lb-ft/rpm)	131.1/1,440 (96.7/1,440)			
Starting Motor	V X kW	12 X 2.3			
Generator	V X A	12 X 55			

### HYDRAULIC COMPONENTS

Hydraulic Pump	Tandem variable displacement piston pumps + gear pump				
Hydraulic Motor	Axial piston				
Hydraulic Motor w/Reducer (Travel)	2-Axial piston, 2-Speed motor				
Control Valve	11-spool valve				
Cylinder (Boom, Arm, Boom swing, Bucket, Dozer)	Double action cylinder				
Return Filter	Filter Type ( $\beta_{10} \geq 8\mu$ )				

### SIDE DIGGING & DOZER

Type	Boom swing by hydraulic cylinder				
Boom Swing Angle	Right	59 degrees			
	Left	70 degrees			
Stroke of Dozer (above/below)	mm (in)	375 / 385 (14.8/15.2)			

## 2. SPECIFICATIONS

---

### MASS

Machine Mass	kg (lb)	Rubber shoe	Iron shoe
		4,900 (10,810)	5,040 (11,110)
Upper swing body	kg (lb)	2,290 (5,050)	<--
Travel system	kg (lb)	1,750 (3,860)	1,900 (4,190)
Attachment (Boom+STD Arm+STD Bucket)	kg (lb)	640 (1,410)	
Oil & Water	kg (lb)	120 (265)	

---

**Note**

This figure is calculated with Japanese standard bucket.

---

2.4 MACHINE & COMPONENTS MASS (DRY)

Unit ; kg (lb)

MODEL	E55Bx			
	RUBBER SHOE		IRON SHOE	
	CANOPY	CAB	CANOPY	CAB
COMPLETE MACHINE	4,900 (10,810)	5,020 (11,070)	5,040 (11,110)	5,160 (11,380)
UPPER FRAME ASSEMBLY (ASSY OF FOLLOWINGS)	2,290 (5,050)	2,410 (5,310)	2,290 (5,050)	2,410 (5,310)
UPPER FRAME	570 (1,257)	<--	<--	<--
CANOPY / CAB	104 (229)	220 (485)	104 (229)	220 (485)
ENGINE	*170 (375)	<--	<--	<--
HYDRAULIC PUMP	*25(55)	<--	<--	<--
RADIATOR	*26 (57)	<--	<--	<--
HYDRAULIC TANK	*35 (77)	<--	<--	<--
FUEL TANK	*24 (53)	<--	<--	<--
BOOM SWING BRACKET	110 (243)	<--	<--	<--
BOOM SWING CYLINDER	*40 (88)	<--	<--	<--
SWING MOTOR	*37 (82)	<--	<--	<--
CONTROL VALVE	*43 (95)	<--	<--	<--
COUNTERWEIGHT	803 (1,771)	<--	<--	<--
GUARD - BONNET	130 (287)	<--	<--	<--
BOOM CYLINDER	*58 (128)	<--	<--	<--
LOWER FRAME ASSEMBLY (ASSY OF FOLLOWINGS)	1,750 (3,860)	<--	1,900 (4,190)	<--
LOWER FRAME	544 (1,200)	<--	<--	<--
SWING BEARING	79 (174)	<--	<--	<--
TRAVEL MOTOR	*69X2 (152X2)	<--	<--	<--
UPPER ROLLER	5X2 (11X2)	<--	<--	<--
LOWER ROLLER	12X10 (27X10)	<--	<--	<--
FRONT IDLER	37X2 (82X2)	<--	<--	<--
IDLER ADJUSTER	23X2 (51X2)	<--	<--	<--
SPROCKET	14X2 (31X2)	<--	<--	<--
RUBBER CRAWLER SHOE	222X2 (490X2)	<--	-	-
400mm (15.7") IRON SHOE	-	-	290X2 (640X2)	-
SWIVEL JOINT	*22 (49)	<--	<--	<--
DOZER	220 (485)	<--	<--	<--
DOZER CYLINDER	*22 (49)	<--	<--	<--
ATTACHMENT ASSEMBLY (ASSY OF FOLLOWINGS)	640 (1,410)	<--	<--	<--
BOOM ASSEMBLY	348 (767)	<--	<--	<--
BOOM	206 (454)	<--	<--	<--
ARM CYLINDER	*50 (110)	<--	<--	<--
ARM ASSEMBLY	186 (410)	<--	<--	<--
ARM	120 (265)	<--	<--	<--
BUCKET CYLINDER	*27 (60)	<--	<--	<--
BUCKET LINK	11 (24)	<--	<--	<--
IDLER LINK	4X2 (9X2)	<--	<--	<--
BUCKET ASSEMBLY (STD)	106 (234)	<--	<--	<--

2



## 2. SPECIFICATIONS

Unit ; kg (lb)

MODEL	E55Bx			
	RUBBER SHOE		IRON SHOE	
	CANOPY	CAB	CANOPY	CAB
FLUIDS (ASSY OF FOLLOWINGS)	120 (265)	<--	<--	<--
HYDRAULIC OIL	51 (112)	<--	<--	<--
FUEL	63 (139)	<--	<--	<--
COOLANT	6 (13)	<--	<--	<--

**Note**

Mark \* shows dry mass.

Bucket mass is shown with Japanese standard bucket mass.

2.5 TRANSPORTATION

(1) LOADING MACHINE ON A TRAILER

1. Keep trailer bed clean. Put chocks against truck wheels.
2. Use a ramp or loading deck. Ramps must be strong enough, have a low angle, and correct height. Load and unload machine on a level surface.
3. Travel machine onto ramps slowly. Center the machine over the trailer.
4. Lower all attachment.
5. Stop engine. Remove key from switch.



Do not put chains over or against hydraulic lines or hoses.

6. Fasten machine to trailer with chains or cables.  
 During transportation, the bucket or attachments may hit the cab. Therefore, set the machine in the transporting position by observing following points:
  - a. Extend the bucket cylinder fully.
  - b. Extend the arm cylinder fully.
  - c. Lower the boom.
  - d. If machine cannot be transported with arm cylinder fully extended, remove bucket or attachment and extend arm cylinder.

(2) TRANSPORTATION DIMENSION AND MASS OF ATTACHMENT

1. BOOM WITH ARM CYLINDER

L X H X W mm(ft-in)	3,100 X 990 X 280 (10'2.1") (40") (11")
Mass kg (lb)	250 (551)

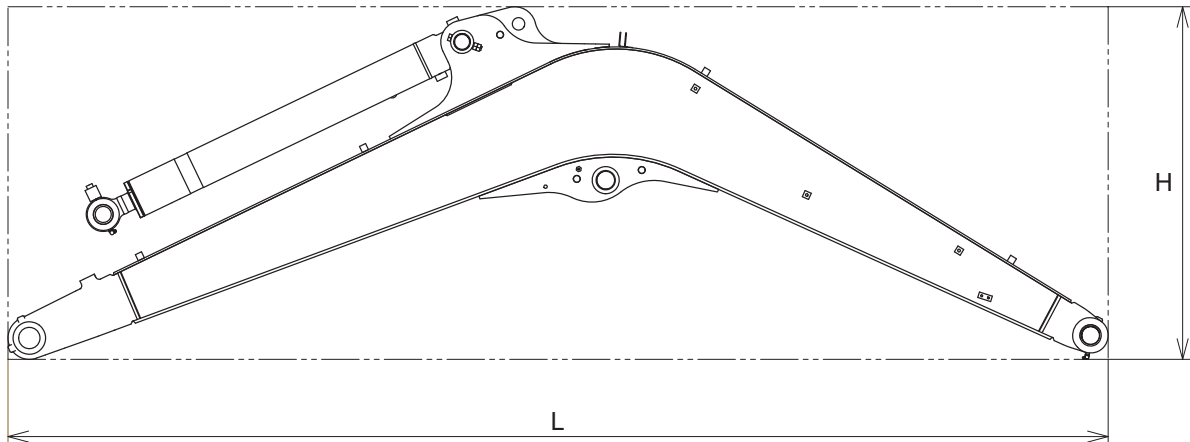

## 2. SPECIFICATIONS

### 2. ARM & BUCKET (Japanese standard bucket)

Item / Type	1.69m(5ft-6.5in)Arm + 0.16m <sup>3</sup> (0.21cu.yd) STD Bucket	1.69m(5ft-6.5in)Arm + 0.21m <sup>3</sup> (0.28cu.yd)Bucket
L X H X W mm (ft-in)	2,900 X 530 x 650 (9'6.2") (20.9") (25.6")	2,900 X 550 X 750 (9'6.2") (21.7") (29.5")
Mass kg (lb)	284 (626)	299 (659)

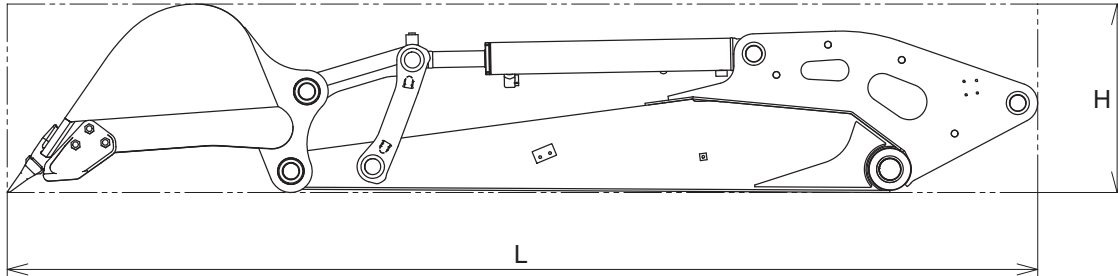

### 3. ARM

L X H X W mm (ft-in)	2,150 X 450 X 230 (7'0.7") (17.7") (9.06")
Mass kg (lb)	180 (397)

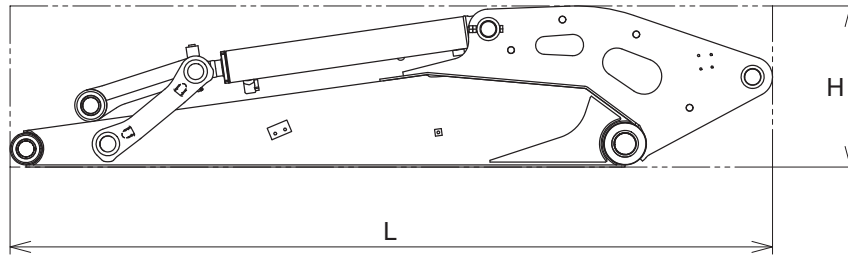

### 4. BUCKET (Japanese standard bucket)

Heaped capacity m <sup>3</sup> (cu-yd)	0.16 (0.21)
L X H X W mm (ft-in)	780 X 690 X 650 (30.7") (27.2") (25.6")
Mass kg (lb)	106 (234)

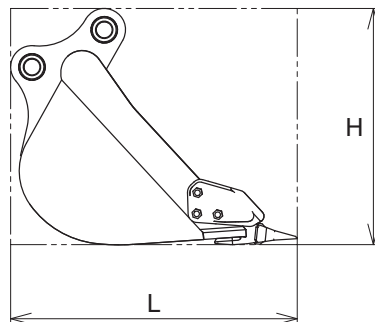

5. DOZER w/o cylinder mass

L X H X W mm (ft-in)	1,250 X 330 X 1,960 (4'1.2") (13") (6'5.2")
Mass kg (lb)	219 (483)

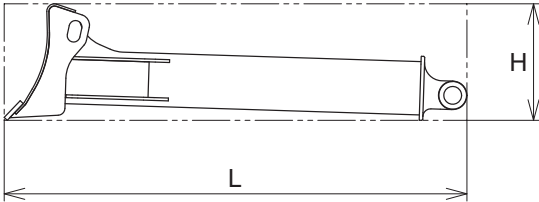

## 2. SPECIFICATIONS

### 2.6 TYPE OF CRAWLER SHOES

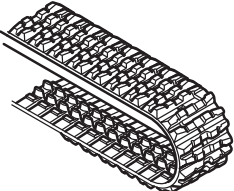
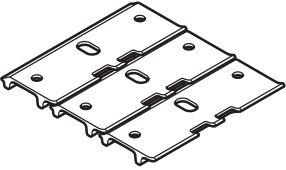
Type	Width mm {in}	Length between center of idler and center of travel motor mm {ft-in}	Ground Pressure kPa {psi}	
			CANOPY	CAB
Rubber belt 	400 {15.7"}		28.0 {4.1}	28.7 {4.2}
Iron shoe (Optional) 	400 {15.7"}		29.7 {4.2}	30.4 {4.4}

2.7 TYPE OF BUCKET

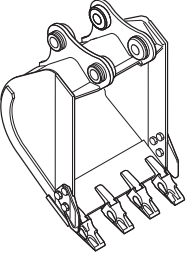
Type	Heaped capacity m <sup>3</sup> (cu.yd)	Outer width mm (in)		Number of tooth	Mass kg (lb)	Remarks
		with side cutter	without side cutter			
Back hoe bucket 	0.16 (0.21)	650 (25.3")	600 (23.6")	4	106 (234)	Standard size

**Note**

This table shows Japanese standard bucket.

## 2. SPECIFICATIONS

### 2.8 ENGINE SPECIFICATIONS

#### 2.8.1 SPECIFICATIONS

Model		E55Bx	
Engine Model (YANMAR)		4TNV88-B	
Type		Vertical, 4-cycle water-cooled diesel engine, DI, NA	
No. of cylinders - Bore × Stroke		4 - 88 mm (3.46 in) × 90 mm (3.54 in)	
Total displacement		2.189 liter (134 cu•in)	
Compression ratio		19.1	
Rated output		28.3 kW (38.5 PS) at 2400 rpm	
Maximum torque		131.1 N•m (96.7 lbf•ft) at 1440 min <sup>-1</sup>	
Low idling		1290±25 min <sup>-1</sup>	
High idling		2590±25 min <sup>-1</sup> (Iso chronous)	
Fuel consumption rate		Less than 243±9 g / kWh (179±6.6 g / PS•h)	
Allowable tilting angles		Continuous ; 30° for all direction	
Rotating direction		Counterclockwise as seen from flywheel side	
Firing order		1-3-4-2-1	
Fuel injection timing (b.T.D.C.)		-	
Valve action		Open	Close
	Intake valve	b.T.D.C. 15±5°	a.B.D.C. 45±5°
	Exhaust valve	b.T.D.C. 56±5°	a.B.D.C. 18±5°
Valve clearance	Intake valve	0.2 mm (0.008 in) in cold condition	
	Exhaust valve	0.2 mm (0.008 in) in cold condition	
Thermostat action		Start 71 ± 1.5°C (160 ± 3°F) / Full open 85°C (185°F)	
Compression pressure		3.43 ± 0.1 MPa (500 ± 14 psi) at 250 min <sup>-1</sup>	
Lubrication oil pressure		0.37 MPa (54 psi) at 2400 min <sup>-1</sup>	
Dimensions L × W × H		696 × 553 × 677 mm (27.4 × 21.8 × 26.7 in)	
Dry mass		170 kg (375 lb)	
Governor		Mechanical centrifugal governor (All speed type)	
Fuel filtration		Full flow type (paper element)	
Lubrication system		Forced lubrication with trochoid pump	
Cooling system		Liquid cooling / Radiator	
Starter capacity		12 V × 2.3kW	
Generator capacity		12 V × 55 A	
Starting aid		Glow plug (11V-88W) 15 sec	
Cooling water capacity : Max / Engine		6.4 / 2.7 liter (1.69 / 0.71 gal)	
Engine oil volume : Max / Effective		7.4 / 4.0 liter (1.96 / 1.06 gal)	

2.8.2 ENGINE PERFORMANCE CURVE

E55Bx

Model : 4TNV88-B

Rated Output : 28.3 kW / 2400 min<sup>-1</sup> (38.5 PS / 2,400 rpm)

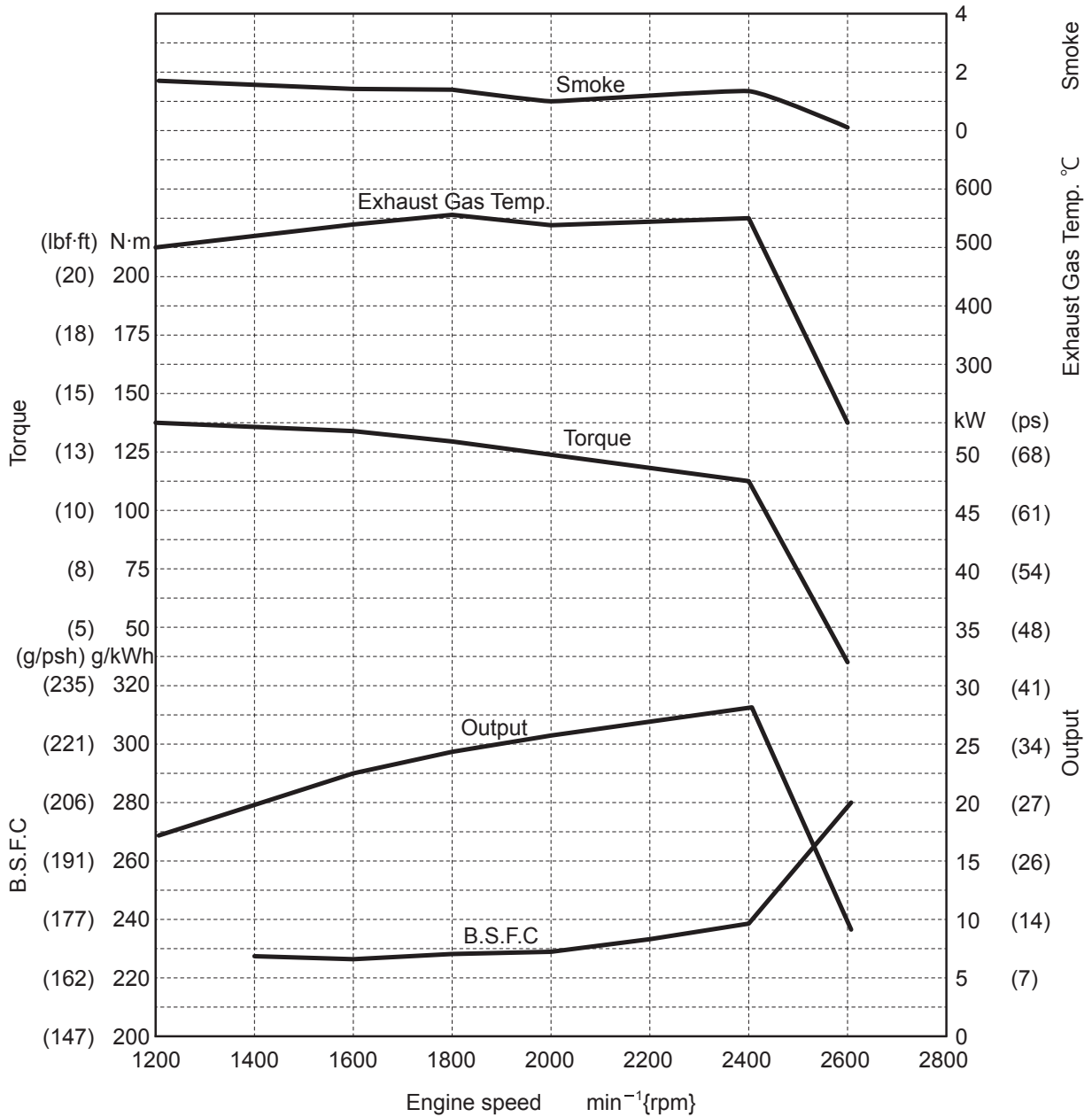

2

$$\begin{aligned} \text{Fuel consumption volume} &= \frac{F}{\rho \times 1000} \times P \times \alpha \\ &= \frac{243}{0.835 \times 1000} \times 28.3 \times \alpha \\ &= 8.24 \alpha \end{aligned}$$

F : Fuel consumption rate (g / kWh)  
 P : Shaft output (kW)  
 ρ : Specific gravity  
 α : Standard load factor (0.60 ~ 0.70)  
 Fuel consumption in normal operation ;  
 4.97 ~ 5.8 L / h (load factor : (0.60 ~ 0.70))



**2. SPECIFICATIONS**

---

# 3. ATTACHMENT DIMENSIONS

## TABLE OF CONTENTS

3.1	BOOM .....	3-3
3.1.1	BOOM DIMENSIONAL DRAWINGS .....	3-3
3.1.2	BOOM MAINTENANCE STANDARDS .....	3-4
3.2	ARM .....	3-8
3.2.1	ARM DIMENSIONAL DRAWINGS .....	3-8
3.2.2	ARM MAINTENANCE STANDARDS .....	3-10
3.3	BUCKET .....	3-13
3.3.1	BUCKET DIMENSIONAL DRAWINGS .....	3-13
3.3.2	DETAIL DIMENSIONAL DRAWINGS OF LUG SECTION .....	3-14
3.3.3	DETAIL DIMENSIONAL DRAWINGS OF BOSS SECTION .....	3-14
3.4	DOZER .....	3-16
3.4.1	DOZER DIMENSIONAL DRAWINGS .....	3-16
3.4.2	DOZER MAINTENANCE STANDARDS .....	3-17
3.5	BOOM SWING .....	3-19
3.5.1	BOOM SWING BRACKET DIMENSIONAL DRAWINGS .....	3-19
3.5.2	BOOM SWING PORTION MAINTENANCE STANDARDS .....	3-20

---

3.1 BOOM

3.1.1 BOOM DIMENSIONAL DRAWINGS

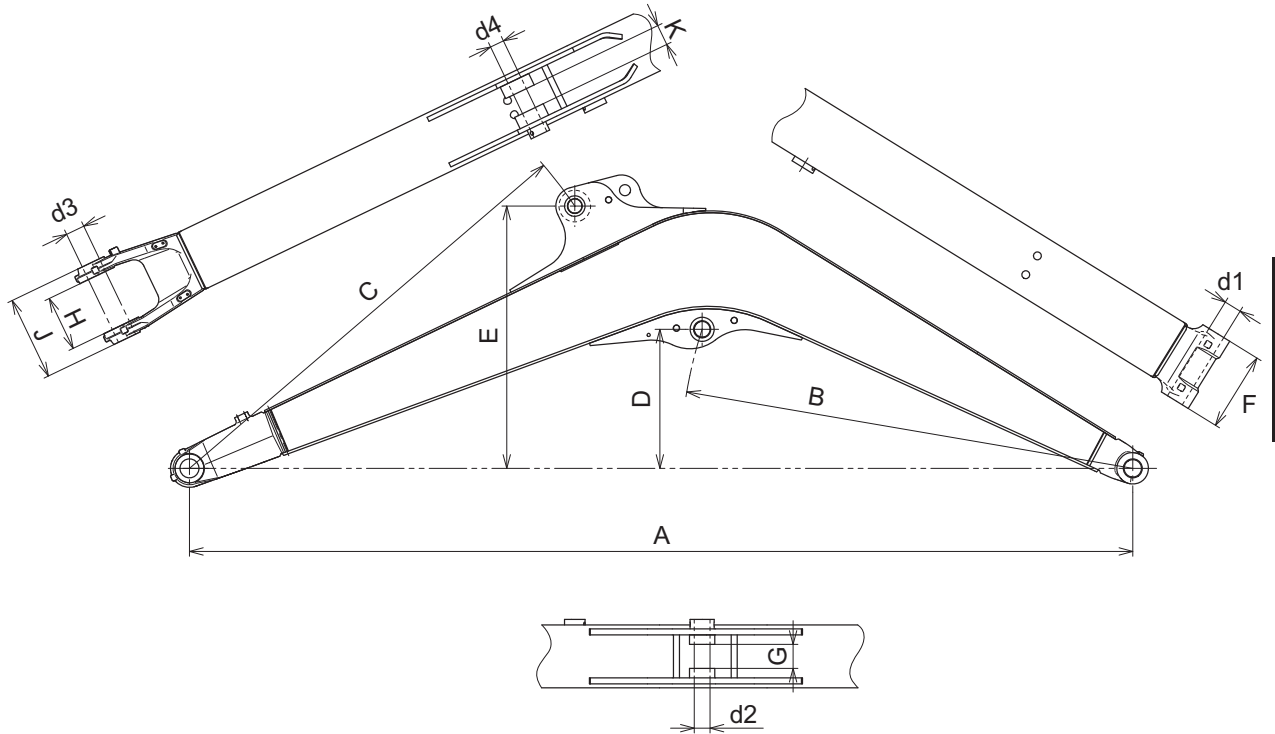

3

Boom Dimensional Drawings

No.	NAME	DIMENSIONS [mm(ft-in)]
A	Boom length	2985 (9'9.52")
B	Distance between pins of boss	R1432 (4'8.38")
C	Distance between pins of bracket	R1475 (4'10.1")
D	Height of boom cylinder rod pin	440 (17.3")
E	Height of arm cylinder (head side) pin	830 (32.7")
F	Boom foot pin dia.	250 (9.84")
G	Inner width of bracket for boom cylinder (rod side) mounting	76 (2.99")
H	Boom end inner width	175 (6.89")
J	Boom end outer width	265 (10.4")
K	Inner width of bracket for arm cylinder (head side)	66 (2.60")
d1	Boom foot pin dia. [Bushing outer dia.]	50 dia.(1.97") [60 dia.(2.36")]
d2	Boom cylinder (rod side) pin dia.	50 dia.(1.97")
d3	Pin dia. of arm end	60 dia.(2.36")
d4	Arm cylinder (head side) pin dia.	45 dia.(1.77")

### 3. ATTACHMENT DIMENSIONS

#### 3.1.2 BOOM MAINTENANCE STANDARDS

##### (1) Clearance of pin and bushing on boom section

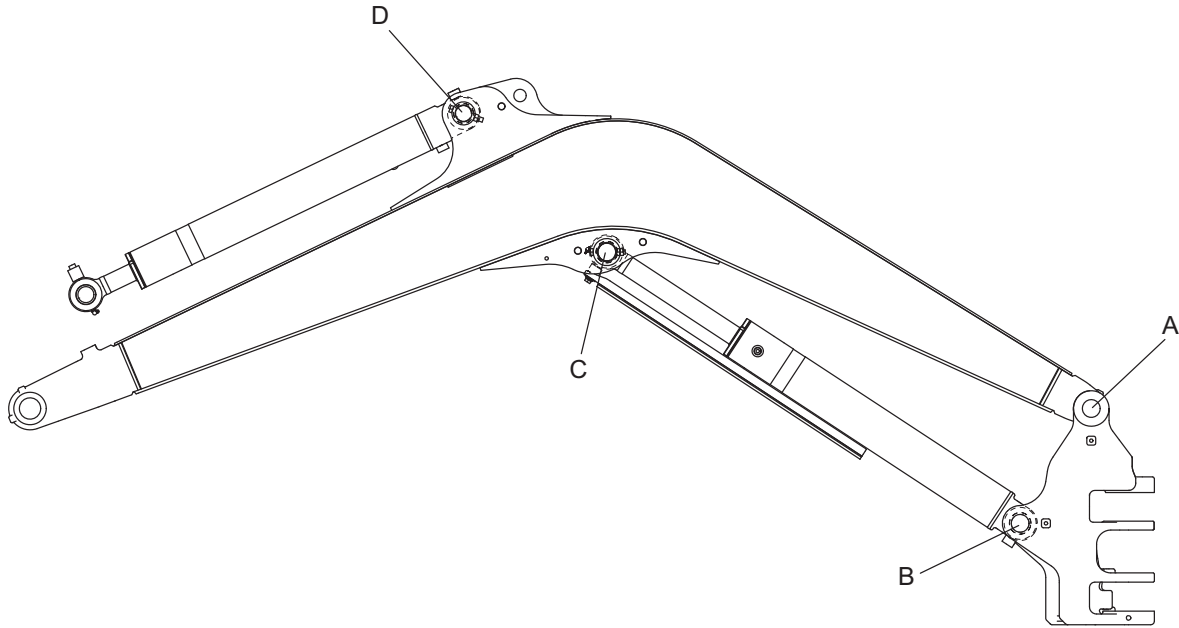

Clearance of pin and bushing on boom section

Unit : mm (in)

Pos.	Item	Pin part No.	Standard dimensions			Clearance			Remedy
			Pin dia.	Tolerance on pin dia.	Tolerance on bushing bore dia.	Standard value	Standard value for repair	Serviceability limit	
A	Boom foot	PS02B01045P1	ø50 (1.97)	-0.02 -0.05 (-0.0008) (-0.0020)	+0.192 +0.130 (+0.0076) (+0.0051)	0.02~ 0.111 (0.0008~ 0.0044)	0.7 (0.028)	1.0 (0.039)	Replace bushing or pin
B	Boom cylinder (Head side)	PS02B01025P1		-0.02 -0.08 (-0.0008) (-0.0031)	+0.25 +0.05 (+0.0098) (+0.0020)	0.07~ 0.03 (0.0028~ 0.0130)			
C	Boom cylinder (Rod side)	PS02B01024P1							
D	Arm cylinder (Head side)	PS02B01035P1	ø45 (1.77)						

**Note**

- The tolerance for bushing inside diameter means the dimension after fitting of it into place.
- The part number for pins may be changed owing to improvement, use them only for reference.

This page is blank for editing convenience.

### 3. ATTACHMENT DIMENSIONS

#### (2) Clearance in thrust direction on boom and cylinder installation section

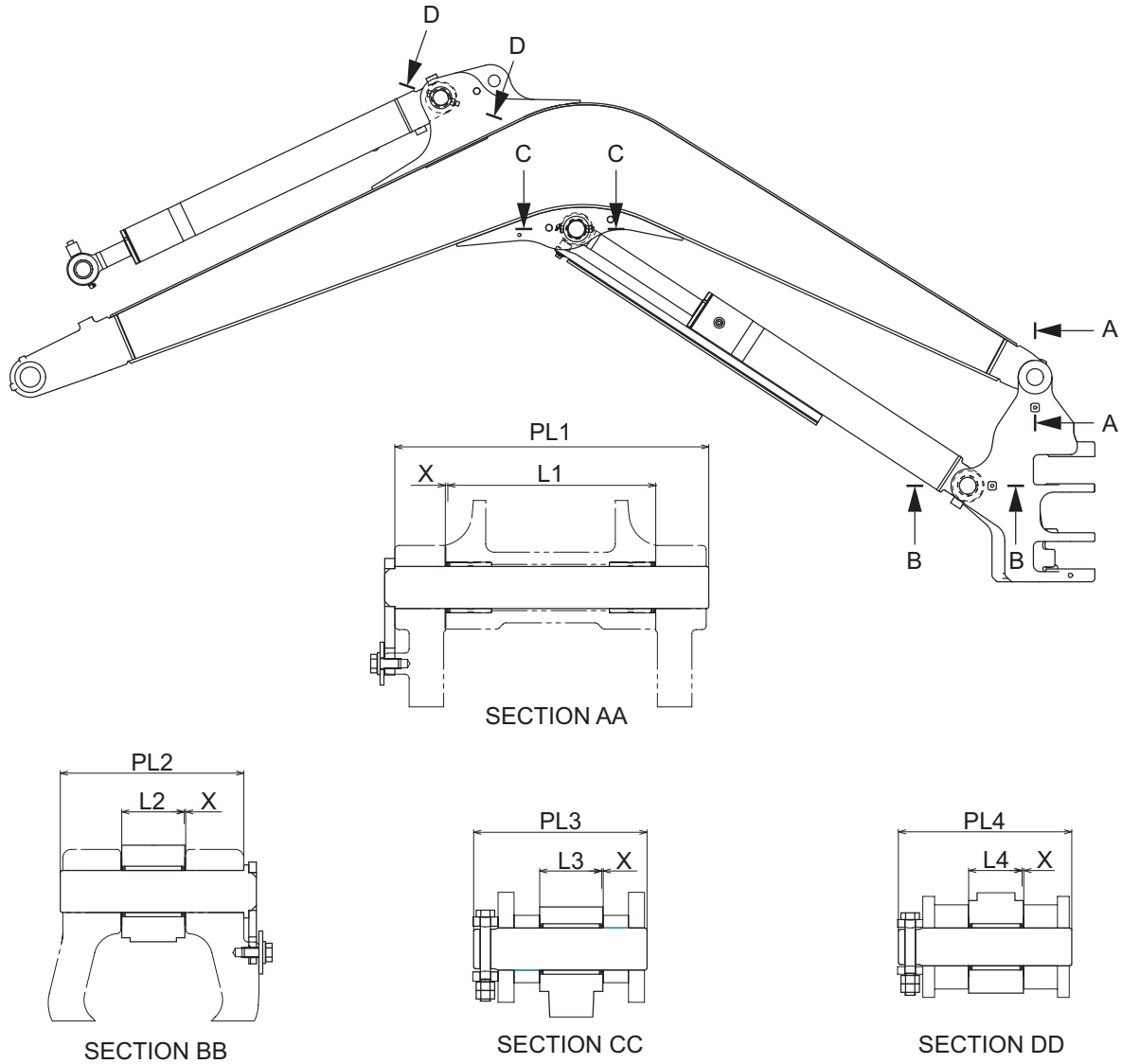

Clearance in thrust direction on boom section

### 3. ATTACHMENT DIMENSIONS

Unit : mm (in)

Sec.	Item		Standard dimensions		Clearance X adjusted with shim (total of both sides)			Remedy	Pin length	
			No.	Dimensions	Standard value	Standard value for repair	Serviceability limit		No.	Dimensions
A-A	Boom foot	Boom	L1	250 <sup>-0.2</sup> <sub>-0.4</sub> (9.84 <sup>-0.008</sup> <sub>-0.016</sub> )	0.1~0.5 (0.004~0.020)				PL1	373 (14.7)
		Swing bracket		250 <sup>+0.2</sup> <sub>0</sub> (9.84 <sup>-0.008</sup> <sub>0</sub> )						
B-B	Boom cylinder (Head side)	Boom cylinder	L2	75 <sup>0</sup> <sub>-0.5</sub> (2.95 <sup>0</sup> <sub>-0.020</sub> )	0.5~1.0 (0.020~0.039)	1.0 (0.039)	1.5 (0.059)	Adjusted with shim	PL2	220 (8.66)
		Swing bracket		77 <sup>+2</sup> <sub>-1</sub> (3.03 <sup>+0.079</sup> <sub>-0.039</sub> )						
C-C	Boom cylinder (Rod side)	Boom cylinder	L3	75 <sup>0</sup> <sub>-0.5</sub> (2.95 <sup>0</sup> <sub>-0.020</sub> )	0.5~0.9 (0.020~0.035)				PL3	209 (8.23)
		Boom		76 <sup>+1</sup> <sub>0</sub> (2.99 <sup>+0.039</sup> <sub>0</sub> )						
D-D	Arm cylinder (Head side)	Arm cylinder	L4	65 <sup>0</sup> <sub>-0.5</sub> (2.56 <sup>0</sup> <sub>-0.020</sub> )	0.5~1.0 (0.020~0.039)				PL4	209 (8.23)
		Boom		66 <sup>+1</sup> <sub>0</sub> (2.60 <sup>+0.039</sup> <sub>0</sub> )						

3



### 3. ATTACHMENT DIMENSIONS

#### 3.2 ARM

##### 3.2.1 ARM DIMENSIONAL DRAWINGS

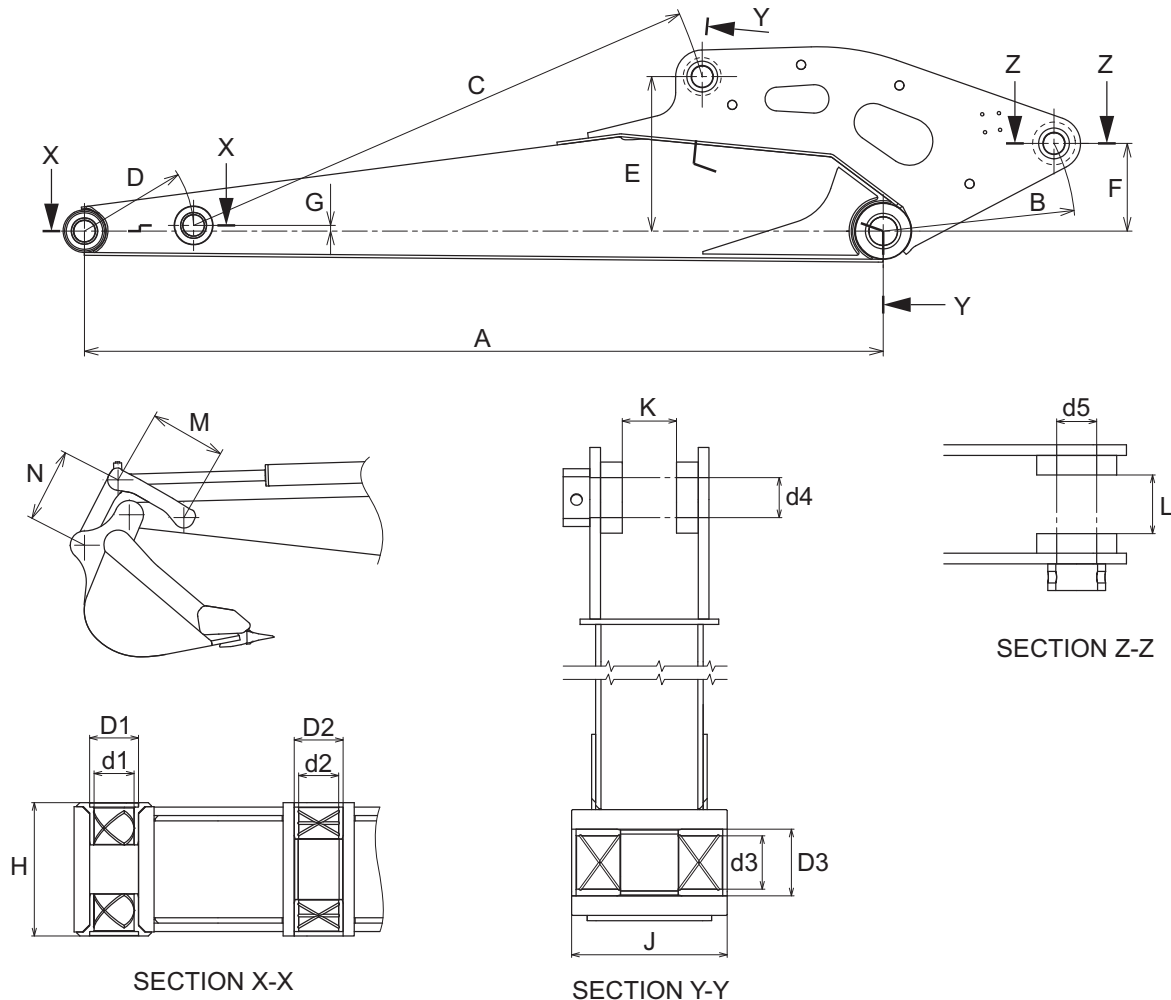

Arm dimensional drawings

### 3. ATTACHMENT DIMENSIONS

No.	Name	Dimensions [mm(ft-in)]
A	Arm length	1685 (5'6.34")
B	Distance between pins of boss and bracket	R405 (15.9")
C	Distance between pins of boss and bracket	R1118 (3'8.02")
D	Distance between pins of boss and boss	R230.5 (9.07")
E	Height between pins of boss and bracket	326 (12.8")
F	Height between pins of boss and bracket	204 (8.03")
G	Height between pins of boss and center	12 (0.472")
H	Boss width	150 (5.91")
J	Boss width	175 (6.89")
K	Bracket inner width	61 (2.40")
L	Bracket inner width	66 (2.60")
M	Idler link dimension	320 (12.6")
N	Bucket link dimension	310 (12.2")
D1	I.D. of boss	55 dia. (2.17")
D2	I.D. of boss	55 dia. (2.17")
D3	I.D. of boss	75 dia. (2.95")
d1	Pin dia.	45 dia. (1.77")
d2	Pin dia.	45 dia. (1.77")
d3	Pin dia.	60 dia. (2.36")
d4	Pin dia.	45 dia. (1.77")
d5	Pin dia.	45 dia. (1.77")

### 3. ATTACHMENT DIMENSIONS

#### 3.2.2 ARM MAINTENANCE STANDARDS

##### (1) Clearance of pin and bushing

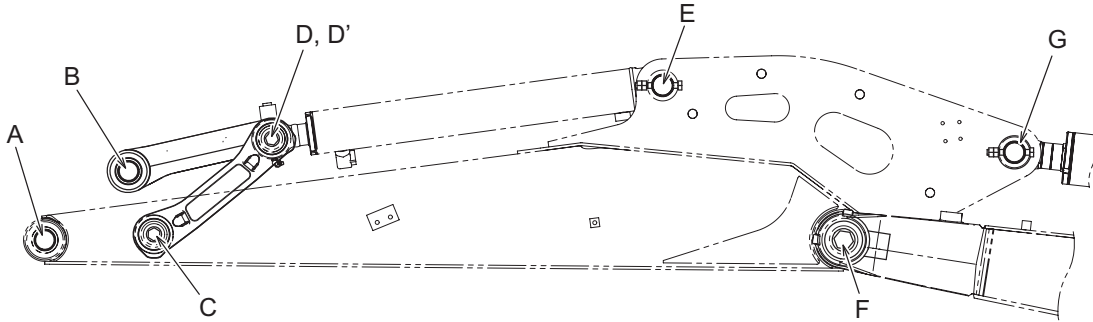

Clearance of pin and bushing on arm section

Unit : mm (in)

Pos.	Item	Pin part No.	Standard dimensions			Clearance			Remedy
			Pin dia.	Tolerance on pin dia.	Tolerance on bushing bore dia.	Standard value	Standard value for repair	Serviceability limit	
A	Arm point (Connected part of bucket)	PH12B01203P1	ø45 (1.77)	-0.02 -0.05 (-0.0008) (-0.0020)	+0.113 +0.088 (+0.0044) (+0.0035)	0.025~ 0.114 (0.0010~ 0.0045)	0.7 (0.028)	1.0 (0.039)	Replace bushing or pin
B	Bucket link (Bucket side)								
C	Idler link (Connected part of arm)	PY12B01158P1			+0.121 +0.105 (+0.0048) (+0.0041)	0.055~ 0.126 (0.0022~ 0.0050)			
D	Bucket link (Idler link side)	PY12B01159P1			+0.121 +0.105 (+0.0048) (+0.0041)	0.052~ 0.123 (0.0020~ 0.0048)			
D'	Bucket cylinder (Rod side)					+0.25 +0.05 (+0.0098) (+0.0020)			
E	Bucket cylinder (Head side)	PS12B01024P1			+0.25 +0.05 (+0.0098) (+0.0020)	0.07~ 0.30 (0.0028~ 0.0118)			
F	Arm foot (Connected part of boom)	PS12B01031P1			ø60 (2.36)	+0.21 +0.17 (+0.0083) (+0.0067)			
G	Arm cylinder (Rod side)	PS12B01024P1	ø45 (1.77)	+0.25 +0.05 (+0.0098) (+0.0020)	0.07~ 0.30 (0.0028~ 0.0118)				

**Note**

- The tolerance for bushing inside diameter means the dimension after fitting of it into place.
- The part number for pins may be changed owing to improvement, use them only for reference.

(2) Clearance in thrust direction on arm and cylinder installation section

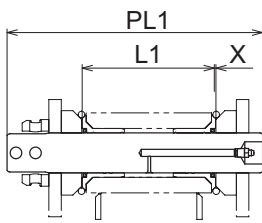
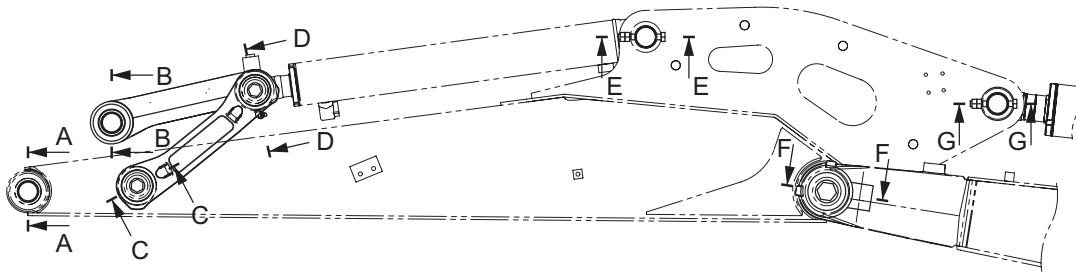

SECTION AA

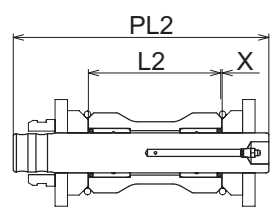

SECTION BB

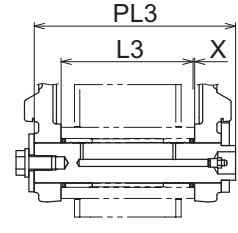

SECTION CC

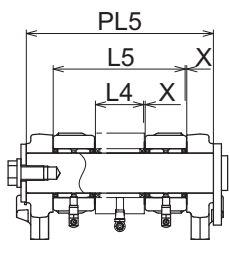

SECTION DD

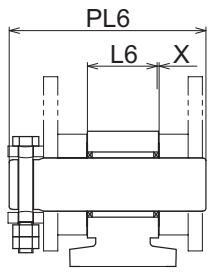

SECTION EE

This clearance is adjusted with shim  
0.1~0.5mm  
(0.004"~0.020")

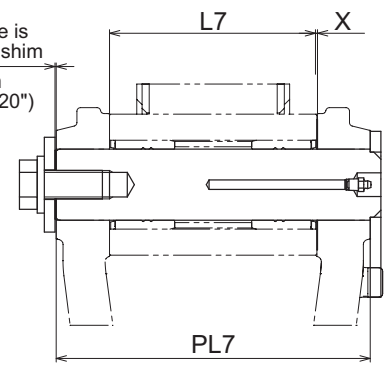

SECTION FF

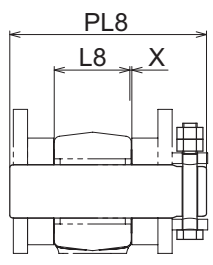

SECTION GG

Clearance in thrust direction on arm section



### 3. ATTACHMENT DIMENSIONS

Unit : mm (in)

Sec.	Item		Standard dimensions		Clearance X adjusted with shim (total of both sides)			Remedy	Pin length			
			No.	Dimensions	Standard value	Standard value for repair	Serviceability limit		No.	Dimensions		
AA	Arm point	Arm	L1	$150_{-0.6}^0$ (5.91 $_{-0.024}^0$ )	0.7~2.2 (0.028~0.087)	See "NOTE"	Adjusted with shim	PL1	287.5 (11.3)			
		Bucket		$151_{-0.5}^{+0.9}$ (5.94 $_{-0.020}^{+0.035}$ )								
BB	Bucket link	Link side	L2	$150_{-0.3}^{-0.2}$ (5.91 $_{-0.012}^{-0.008}$ )								
		Bucket		$151_{-0.5}^{+0.9}$ (5.94 $_{-0.020}^{+0.035}$ )								
CC	Idler link (Connected part of arm)	Arm	L3	$150_{-0.4}^{-0.2}$ (5.91 $_{-0.016}^{-0.008}$ )				0.1~0.5 (0.004~0.020)	—	PL3	210.5 (8.29)	
		Link side		— (—)								
DD	Bucket link (Rod side)	Rod side	L4	$55_{-0.5}^0$ (2.165 $_{-0.020}^0$ )				0.6~1.0 (0.024~0.039)	1.5 (0.059)	2.0 (0.079)	PL5	210.5 (8.29)
		Link side		$57 \pm 0.4$ (2.24 $\pm 0.016$ )								
	Bucket link (Idler link side)	Bucket link	L5	$150_{-0.5}^{-0.2}$ (5.91 $_{-0.020}^{-0.008}$ )	0.1~0.5 (0.004~0.020)	—						
		Idler link		— (—)								
EE	Bucket cylinder (Head side)	Head side	L6	$60_{-0.5}^0$ (2.36 $_{-0.020}^0$ )	0.5~0.9 (0.020~0.035)	PL6	169 (6.65)					
		Arm		$61_0^{+1}$ (2.40 $_{0}^{+0.039}$ )								
FF	Arm foot	Arm	L7	$175_{-0.4}^{-0.2}$ (6.89 $_{-0.016}^{-0.008}$ )	Less than 0.5 (0.020)	1.0 (0.039)	1.5 (0.059)	PL7	266 (10.08)			
		Boom		$175_0^{+0.5}$ (6.89 $_{0}^{+0.020}$ )								
GG	Arm cylinder (Rod side)	Rod side	L8	$65_{-0.5}^0$ (2.56 $_{-0.020}^0$ )	0.5~0.9 (0.020~0.035)	PL8	169 (6.65)					
		Arm		$66_0^{+1}$ (2.60 $_{0}^{+0.039}$ )								

**Note**

Clearance X shall be adjusted using shims, if clearance exceeds the standard value.

3.3 BUCKET

3.3.1 BUCKET DIMENSIONAL DRAWINGS

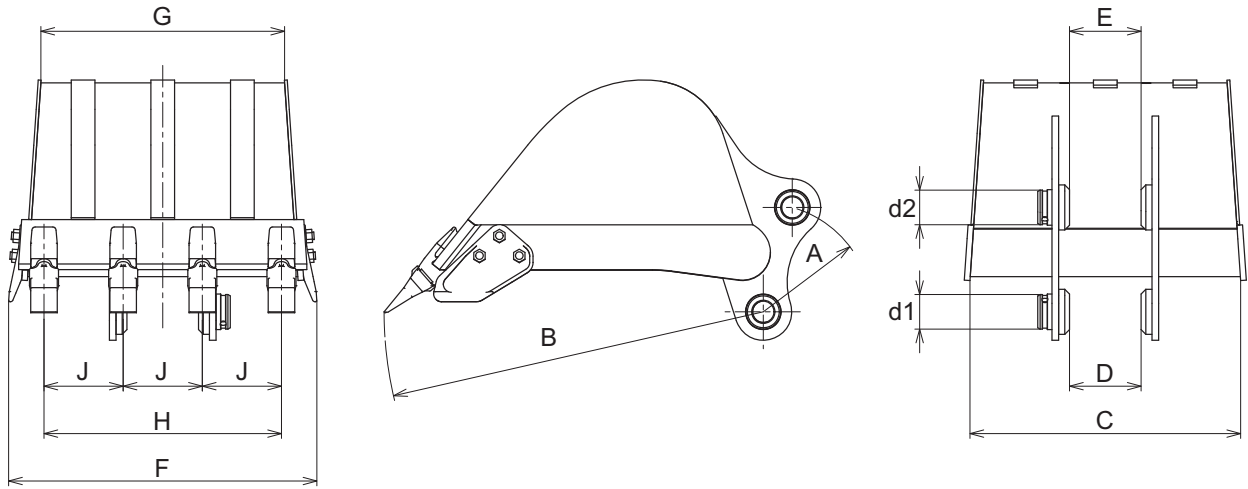

3

Bucket dimensional drawings

No.	Heaped Capacity m <sup>3</sup> (cu-yd)	0.16 (0.20)
A	Distance between pin and bracket	228.5 (9")
B	Distance between bucket pin and tooth end	R800 (31.5")
C	Inner width of bucket top end	571 (22.5")
D	Inner width of lug	151 (5.95")
E	Inner width of bracket	151 (5.49")
F	Outer width of side cutter	650 (25.6")
G	Outer width of bucket bottom plate	514.1 (20.2")
H	Outer tooth distance	501 (19.7")
J	Pitch between teeth	167 (6.57")
d1	Pin dia.	45 dia.(1.77")
d2	Pin dia.	45 dia.(1.77")

**Note**

1. Japanese standard bucket.

### 3. ATTACHMENT DIMENSIONS

#### 3.3.2 DETAIL DIMENSIONAL DRAWINGS OF LUG SECTION

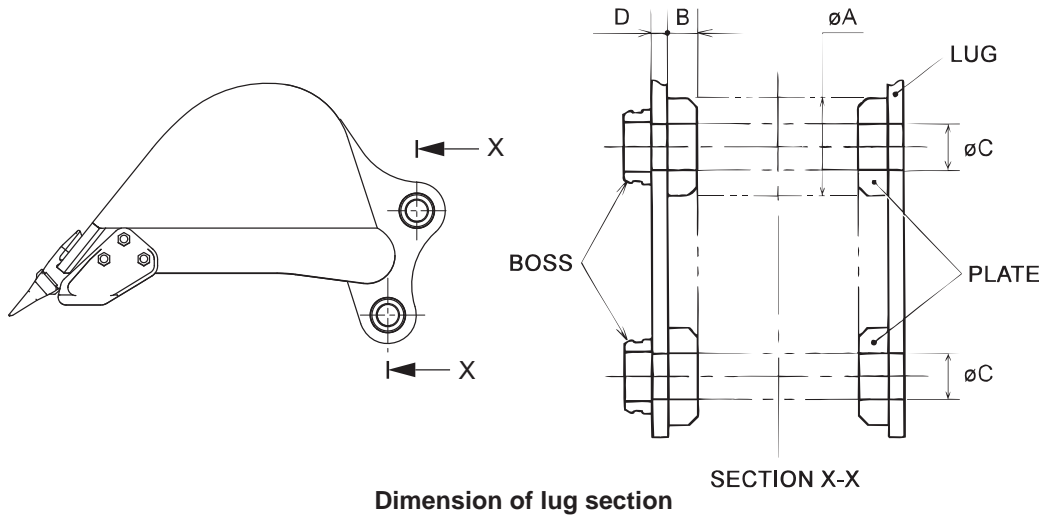

Unit : mm (in)

Portion	Plate outer dia. $\phi A$	Boss thickness B	Pin bore dia. $\phi C$	Lug plate thickness D
Dimensions	$\phi 95$ (3.74)	23 (0.906)	$\phi 45^{+0.1}_0$ (1.77 <sup>+0.004</sup> <sub>0</sub> )	14 (0.551)

#### 3.3.3 DETAIL DIMENSIONAL DRAWINGS OF BOSS SECTION

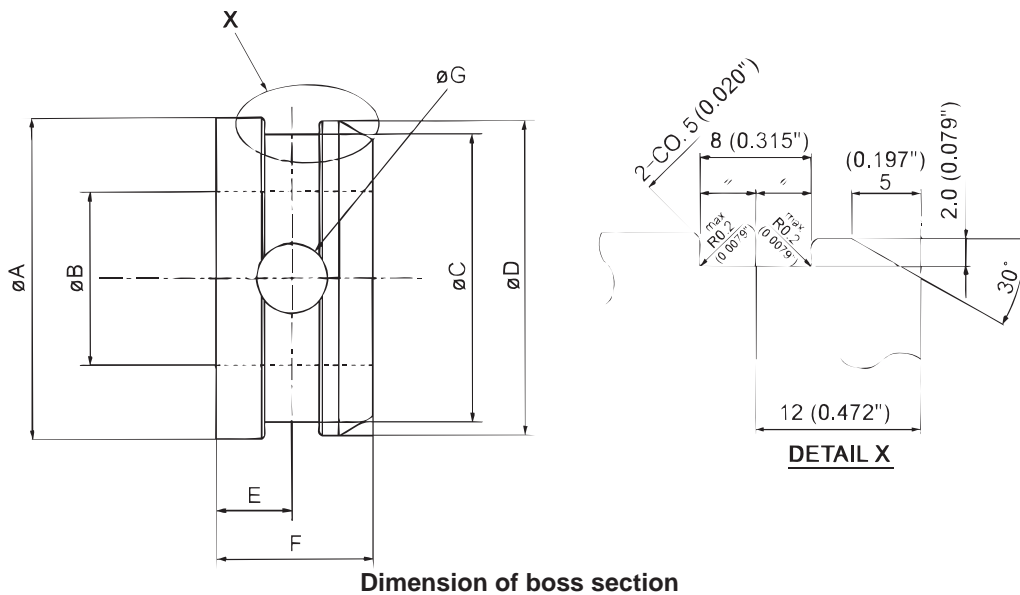

Unit : mm (in)

Portion	$\phi A$	$\phi B$	$\phi C$	$\phi D$	E	F	$\phi G$
Dimensions	75 (2.95)	49 (1.93)	69 (2.72)	73 (2.87)	15 (0.591)	30 (1.18)	13 (0.521)

This page is blank for editing convenience.



### 3. ATTACHMENT DIMENSIONS

#### 3.4 DOZER

##### 3.4.1 DOZER DIMENSIONAL DRAWINGS

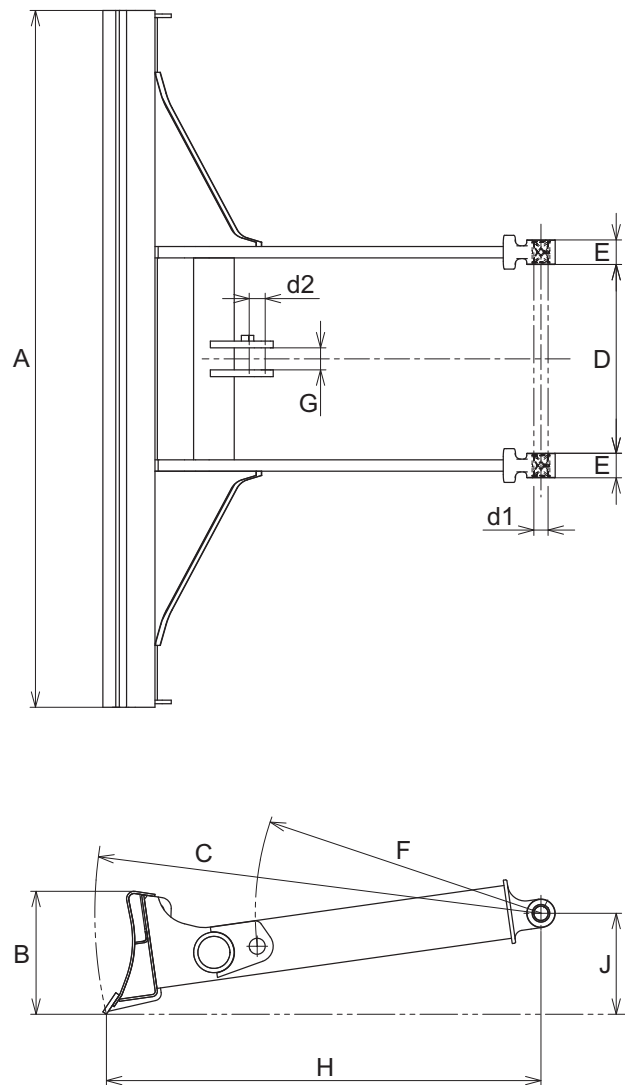

**Dozer dimensional drawings**

No.	NAME	Dimensions [mm(ft-in)]
A	Blade width	1960 (6'5.17")
B	Blade height	346 (13.6")
C	Distance from dozer attaching pin center to cutting edge end	R1251 (4'1.25")
D	Inner width of dozer attaching bracket	531 (20.9")
E	Width of dozer attaching bracket	69 (2.72")
F	Distance from dozer attaching pin center to attaching pin on dozer cylinder head side	R803.5 (31.63")
G	Attaching bracket inner width on dozer cylinder head side	62 (2.44")
H	Horizontal distance from dozer attaching pin center to edge end	1222 (4'0.11")
J	Vertical distance from dozer attaching pin center to edge end	285 (11.2")
d1	Dozer attaching pin dia.	40 dia.(1.57")
d2	Attaching pin dia. on dozer cylinder head side	45 dia.(1.77")

3.4.2 DOZER MAINTENANCE STANDARDS

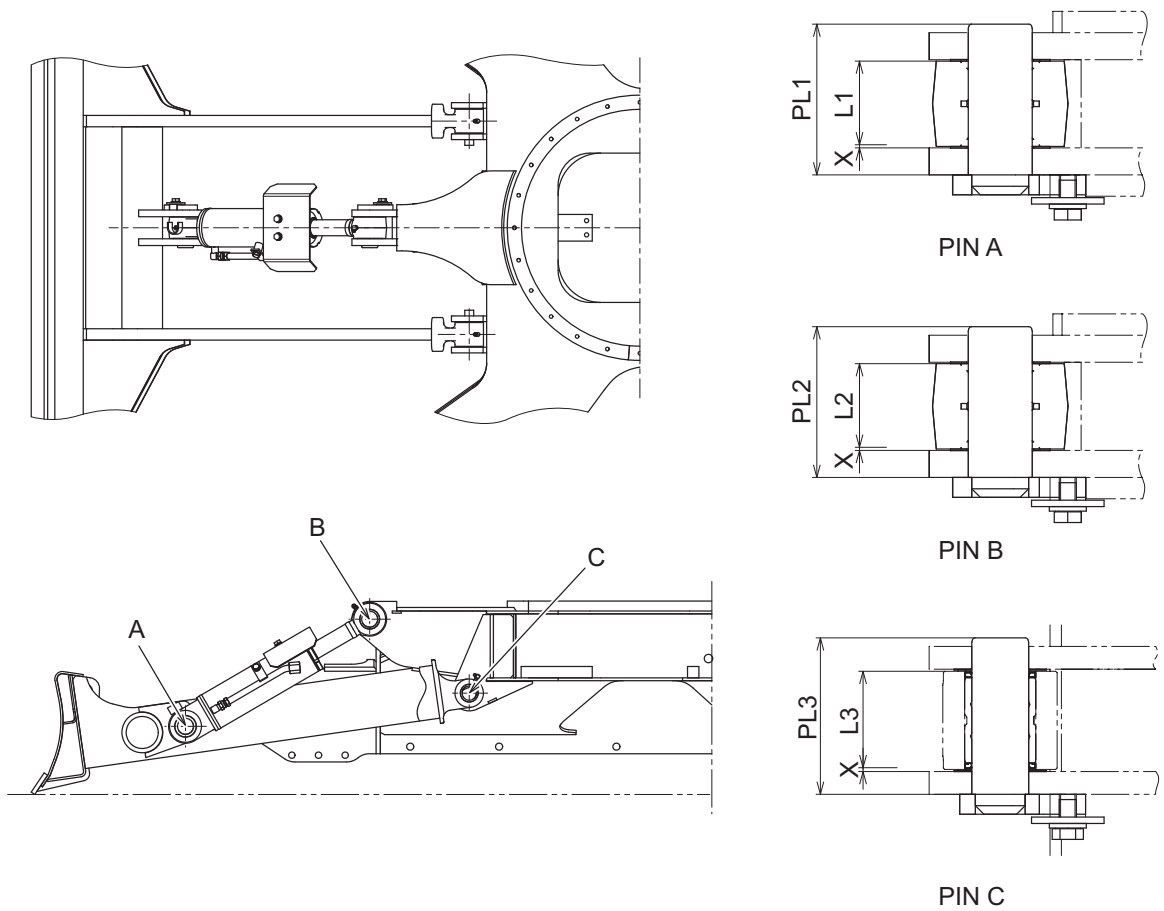

3

Dozer maintenance standards

(1) Clearance of pin and bushing

Unit : mm (in)

Pos.	Item	Pin part No.	Standard dimension			Clearance			Remedy
			Pin dia.	Tolerance on pin dia.	Tolerance on bushing bore dia.	Standard value	Standard value for repair	Serviceability limit	
A	Dozerblade cylinder (Head side)	PS51B01110P1	ø45 (1.77)	-0.05	+0.25	0.36~	1.5 (0.059)	2.0 (0.079)	Replace bushing or pin
B	Dozerblade cylinder (Rod side)			-0.11	+0.05	0.10			
C	Dozerblade foot	PS51B01013P1	ø40 (1.57)	-0.06	+0.215	0.175~			
				-0.09	+0.115	0.305			
				(-0.0024)	(+0.0085)	(0.0069~			
				(-0.0035)	(+0.0045)	0.0120)			

**Note**

- The tolerance for bushing inside diameter means the dimension after fitting of it into place.
- The part number for pins may be changed owing to improvement, use them only for reference.

This as a preview PDF file from [best-manuals.com](http://best-manuals.com)



Download full PDF manual at [best-manuals.com](http://best-manuals.com)