

SERVICE MANUAL

T4.75F / T4.85F / T4.95F / T4.105F

Tier 3

Tractor

*T4.75F with cab PIN ZDJD10166 and above; T4.75F without cab PIN ZDJD10836 and above;
T4.85F with cab PIN ZDJD11099 and above; T4.85F without cab PIN ZDJD11022 and above;
T4.95F with cab PIN ZDJD10640 and above; T4.95F without cab PIN ZDJD10215 and above;
T4.105F with cab PIN ZDJD11527 and above; T4.105F without cab PIN ZDJD11911 and above*

Part number 47888362

1st edition English
July 2016





SERVICE MANUAL

T4.105F With cab [ZDJD11527 -], T4.105F Without cab [ZDJD11911 -], T4.75F With cab [ZDJD10166 -], T4.75F Without cab [ZDJD10836 -], T4.85F With cab [ZDJD11099 -], T4.85F Without cab [ZDJD11022 -], T4.95F With cab [ZDJD10640 -], T4.95F Without cab [ZDJD10215 -]

Link Product / Engine

Product	Market Product	Engine
T4.105F With cab [ZDJD11527 -]	North America	F4CE9484
T4.105F Without cab [ZDJD11911 -]	North America	F4CE9484
T4.75F With cab [ZDJD10166 -]	North America	F5AE9484B
T4.75F Without cab [ZDJD10836 -]	North America	F5AE9484B
T4.85F With cab [ZDJD11099 -]	North America	F5AE9484G
T4.85F Without cab [ZDJD11022 -]	North America	F5AE9484G
T4.95F With cab [ZDJD10640 -]	North America	F4CE9484
T4.95F Without cab [ZDJD10215 -]	North America	F4CE9484

Contents

INTRODUCTION

Engine.....	10
[10.001] Engine and crankcase	10.1
Clutch	18
[18.104] Clutch hydraulic release control.....	18.1
[18.110] Clutch and components	18.2
[18.100] Clutch mechanical release control	18.3
Transmission.....	21
[21.114] Mechanical transmission	21.1
[21.118] Transmission/Rear drive	21.2
[21.140] Mechanical transmission internal components.....	21.3
[21.112] Power shuttle transmission.....	21.4
[21.134] Power shuttle transmission external controls	21.5
[21.154] Power shuttle transmission internal components	21.6
[21.162] Reverser	21.7
[21.168] Hi-Lo unit.....	21.8
Four-Wheel Drive (4WD) system	23
[23.304] Four-Wheel Drive (4WD) gearbox	23.1
[23.314] Drive shaft.....	23.2
Front axle system	25
[25.100] Powered front axle	25.1
[25.102] Front bevel gear set and differential	25.2
[25.108] Final drive hub, steering knuckles, and shafts	25.3
[25.310] Final drives	25.4
Rear axle system.....	27
[27.100] Powered rear axle.....	27.1

[27.106] Rear bevel gear set and differential	27.2
[27.120] Planetary and final drives	27.3
[27.126] Spur gear and final drives	27.4
Power Take-Off (PTO)	31
[31.101] Rear mechanical control	31.1
[31.146] Front Power Take-Off (PTO)	31.2
Brakes and controls	33
[33.202] Hydraulic service brakes	33.1
[33.110] Parking brake or parking lock	33.2
[33.220] Trailer brake hydraulic control.....	33.3
Hydraulic systems.....	35
[35.000] Hydraulic systems.....	35.1
[35.300] Reservoir, cooler, and filters.....	35.2
[35.104] Fixed displacement pump.....	35.3
[35.204] Remote control valves	35.4
[35.600] High flow hydraulics	35.5
[35.100] Main lift system.....	35.6
[35.114] Three-point hitch control valve	35.7
[35.116] Three-point hitch cylinder	35.8
[35.160] Front hitch controls and lines	35.9
[35.410] Header or attachment height system	35.10
Hitches, drawbars, and implement couplings.....	37
[37.110] Rear three-point hitch	37.1
[37.162] Front hitch.....	37.2
Steering.....	41
[41.101] Steering control	41.1
[41.200] Hydraulic control components.....	41.2
Wheels	44

[44.511] Front wheels.....	44.1
Cab climate control	50
[50.100] Heating	50.1
[50.104] Ventilation	50.2
[50.200] Air conditioning.....	50.3
Electrical systems	55
[55.000] Electrical system	55.1
[55.100] Harnesses and connectors.....	55.2
[55.201] Engine starting system	55.3
[55.301] Alternator.....	55.4
[55.302] Battery.....	55.5
[55.202] Cold start aid	55.6
[55.640] Electronic modules	55.7
[55.048] Rear Power Take-Off (PTO) control system	55.8
[55.051] Cab Heating, Ventilation, and Air-Conditioning (HVAC) controls.....	55.9
[55.050] Heating, Ventilation, and Air-Conditioning (HVAC) control system.....	55.10
[55.523] Cab hitch controls	55.11
[55.130] Rear three-point hitch electronic control system	55.12
[55.518] Wiper and washer system.....	55.13
[55.404] External lighting	55.14
[55.514] Cab lighting	55.15
[55.511] Light harnesses	55.16
[55.408] Warning indicators, alarms, and instruments	55.17
[55.DTC] FAULT CODES.....	55.18
Platform, cab, bodywork, and decals.....	90
[90.150] Cab.....	90.1
[90.151] Cab interior.....	90.2
[90.154] Cab doors and hatches	90.3

[90.160] Cab interior trim and panels..... 90.4



INTRODUCTION

Contents

INTRODUCTION

Note to the Owner WARNINGS FOR AIR CONDITIONING SYSTEM REPAIR OPERATIONS (*)	3
.....	3
Advice Important notice	4
.....	4
Safety rules SAFETY REGULATIONS	5
.....	5
Personal safety CAB AIR CONDITIONING SYSTEM (*)	8
.....	8
Basic instructions	9
.....	9
Consumables	11
.....	11
Consumables	12
.....	12

(*) See content for specific models

Note to the Owner WARNINGS FOR AIR CONDITIONING SYSTEM REPAIR OPERATIONS

T4.105F With cab [ZDJD11527 -]	NA
T4.75F With cab [ZDJD10166 -]	NA
T4.85F With cab [ZDJD11099 -]	NA
T4.95F With cab [ZDJD10640 -]	NA

Starting the system at low temperatures can damage the compressor. Only operate the air conditioner when the engine is hot and the temperature inside the cab is at least **20 °C (68.00 °F)**.

When disconnecting the hoses, close the ends with plastic caps to prevent foreign matter and humidity from getting inside the hoses.

Handle the thermostatic sensor carefully to avoid damage that may prevent efficient system operation.

Always use two spanners to unscrew the hose fittings to avoid twisting the fitting.

Do not use any type of engine oil to lubricate the compressor and the system.

Never leave the compressor oil container open, always make sure that it is tightly closed. If left exposed the oil will absorb humidity from the air and may, subsequently, damage the system.

Do not transfer compressor oil from the original container to another container.

Do not introduce any additives to the compressor oil. Any additional substances could contain elements which are incompatible with the chemical base of the refrigerant and thus alter its characteristics.

Check that the thermostatic sensor is correctly inserted in the fins on the evaporator to ensure efficient system operation.

Advice Important notice

All maintenance and repair work described in this manual must be performed exclusively by NEW HOLLAND service technicians, in strict accordance with the instructions given and using any specific tools necessary. Anyone performing the operations described herein without strictly following the instructions is personally responsible for any eventual injury or damage to property.

Safety rules SAFETY REGULATIONS

TO PREVENT ACCIDENTS

Most accidents or injuries that occur in workshops are the result of non-observance of simple and fundamental safety regulations.

For this reason, IN MOST CASES THESE ACCIDENTS CAN BE AVOIDED: by foreseeing possible causes and consequently acting with the necessary caution and care.

Accidents may occur with all types of vehicle, regardless of how well it was designed and built.

A careful and judicious service technician is the best guarantee against accidents.

Precise observance of the most basic safety rule is normally sufficient to avoid many serious accidents.

DANGER: Never carry out any cleaning, lubrication or maintenance operations when the engine is running.

GENERAL

- Carefully follow specified repair and maintenance procedures.
- Do not wear rings, wristwatches, jewellery, unbuttoned or loose articles of clothing such as: ties, torn clothing, scarves, open jackets or shirts with open zips that may remain entangled in moving parts.
It is advised to wear approved safety clothing, e.g: non-slip footwear, gloves, safety goggles, helmets, etc.
- Do not carry out repair operations with someone sitting in the driver's seat, unless the person is a trained technician who is assisting with the operation in question.
- Operate the vehicle and use the implements exclusively from the driver's seat.
- Do not carry out operations on the vehicle with the engine running, unless specifically indicated.
- Stop the engine and ensure that all pressure is relieved from hydraulic circuits before removing caps, covers, valves, etc.
- All repair and maintenance operations must be carried out using extreme care and attention.
- Service steps and platforms used in a workshop or in the field should be built in compliance with the safety rules in force.
- Disconnect the batteries and label all controls to indicate that the vehicle is being serviced. Block the machine and all equipment which should be raised.
- Do not check or fill fuel tanks, accumulator batteries, nor use starting liquid when smoking or near naked flames, as these fluids are inflammable.
- Brakes are inoperative if manually released for repair or maintenance purposes.
In such cases, the machine should be kept constantly under control using blocks or similar devices.
- The fuel nozzle should always be in contact with the filling aperture. Maintain this position until filling operations are completed in order to avoid possible sparks caused by the accumulation of static electricity.
- Only use specified towing points for towing the tractor, connect parts carefully. Make sure that all pins and/or locks are secured in position before applying traction.
Never remain near the towing bars, cables or chains that are operating under load
- Transport vehicles that cannot be driven using a trailer or a low-loading platform trolley, if available.
- When loading or unloading the vehicle from the trailer (or other means of transport), select a flat area capable of sustaining the trailer or truck wheels, firmly secure the tractor to the truck or trailer and lock the wheels in the position.
- Electric heaters, battery-chargers and similar equipment must only be powered by auxiliary power supplies with efficient ground insulation to avoid electrical shock hazards.
- Always use suitable hoisting or lifting devices when raising or moving heavy parts.
- Take extra care if bystanders are present.
- Never pour gasoline or diesel oil into open, wide and low containers.
- Never use gasoline, diesel oil or other inflammable liquids as cleaning agents. Use non-flammable non-toxic proprietary solvents.
- Wear safety goggles with side guards when cleaning parts with compressed air.
- Limit the air pressure to a maximum of **2.1 bar (30.5 psi)**, according to local regulations.

INTRODUCTION

- Do not run the engine in confined spaces without suitable ventilation.
- Do not smoke, use naked flames, or cause sparks in the area when fuel filling or handling highly inflammable liquids.
- Never use naked flames for lighting when working on the machine or checking for leaks.
- All movements must be carried out carefully when working under, on or near the vehicle and wear protective equipment: helmets, goggles and special footwear.
- When carrying out checks with the engine running, request the assistance of an operator in the driver's seat. The operator must maintain visual contact with the service technician at all times.
- If operating outside the workshop, position the vehicle on a flat surface and lock in position. If working on a slope, lock the vehicle in position and move to a flat area as soon as is safely possible.
- Damaged or bent chains or cables are unreliable. Do not use them for lifting or towing.
Always use suitable protective gloves when handling chains or cables.
- Chains should always be safely secured. Ensure that fastening device is strong enough to hold the load foreseen. No persons should stop near the fastening point, trailing chains or cables.
- Maintenance and repair operations must be carried out in a CLEAN and DRY area, eliminate any water or oil spillage immediately.
- Do not create piles of oil or grease--soaked rags as they represent a serious fire hazard; store them in a closed metal container.
Before starting the vehicle or implements, make sure that the driver's seat is locked in position and always check that the area is free of persons or obstacles.
- Empty pockets of all objects that may fall unobserved into the vehicle parts when disassembled.
- In the presence of protruding metal parts, use protective goggles or goggles with side guards, helmets, special footwear and gloves.
- Handle all parts carefully, do not put your hands or fingers between moving parts, wear suitable safety clothing -- safety goggles, gloves and shoes.

WELDING OPERATIONS

- When welding, use protective safety devices: tinted safety goggles, helmets, special overalls, gloves and footwear. All persons present in the area where welding is taking place must wear tinted goggles.
NEVER LOOK AT THE WELDING ARC IF YOUR EYES ARE NOT SUITABLY PROTECTED.
- Where possible, remove the part or tool that requires arc welding from the tractor.
- Disconnect both battery leads. Isolate the cable ends to avoid contact with each other and the tractor.
- Position the welder ground clamp as near as possible to the area where welding is taking place.
- Remove the electronic control units located on the tractor if welding is to be carried out near these control units.
- Never allow welding cables to lay on, near or across any electrical wiring or electronic component while welding is in progress.
- Metal cables tend to fray with repeated use. Always use suitable protective devices (gloves, goggles, etc.) when handling cables.

START UP

- Never start the engine in confined spaces that are not equipped with adequate ventilation for exhaust gas extraction.
- Never place the head, body, limbs, feet, hands or fingers near fans or rotating belts.

ENGINE

- Always loosen the radiator cap slowly before removing it to allow any remaining pressure in the system to be discharged. Coolant should be topped up only when the engine is stopped or idle if hot.
- Never fill up with fuel when the engine is running, especially if hot, in order to prevent the outbreak of fire as a result of fuel spillage
- Never check or adjust fan belt tension when the engine is running.
Never adjust the fuel injection pump when the vehicle is moving.

- Never lubricate the vehicle when the engine is running.

ELECTRICAL SYSTEMS

- If it is necessary to use auxiliary batteries, remember that both ends of the cables must be connected as follows: (+) with (+) and (-) with (-).
- Avoid short-circuiting the terminals. **GAS RELEASED FROM BATTERIES IS HIGHLY INFLAMMABLE.**
- During charging, leave the battery compartment uncovered to improve ventilation.
- Never check the battery charge using "jumpers" (metal objects placed on the terminals).
- Avoid sparks or flames near the battery zone to prevent explosion hazards.
- Before servicing operations, check for fuel or current leaks. Eliminate any eventual leaks before starting work.
- Never charge batteries in confined spaces. Make sure that there is adequate ventilation in order to prevent accidental explosion hazards as a result of the accumulation of gases released during charging operations.
- Always disconnect the battery before performing any kind of servicing on the electrical system.

HYDRAULIC SYSTEMS

- Some fluid slowly coming out from a very small port can be almost invisible and be strong enough to penetrate the skin. Check for leaks using a piece of cardboard, **NEVER USE HANDS.**
- If any liquid penetrates skin tissue, call for medical aid immediately
- Serious skin infections may result if medical attention is not given.
- Use the specific tools when checking pressure values on the hydraulic system.

WHEELS AND TYRES

- Check that the tyres are correctly inflated at the pressure specified by the manufacturer. Periodically check possible damages to the rims and tyres.
- Stand away from (at the side of) the tire when checking inflation pressure.
- Only check pressure when the vehicle is unloaded and the tires are cold, to avoid incorrect readings as a result of over--pressure.
- Do not re--use parts of recovered wheels as incorrect welding or brazing may heat the material, causing it to weaken and eventually damage or break the wheel.
- Never cut, nor weld a rim with the inflated tyre assembled.
- When removing the wheels, lock both the front and rear vehicle wheels.
- Always position support stands when raising the vehicle, in order to conform to current safety regulations.
- Deflate the tyre before removing any object caught into the tyre tread.
- Never inflate tires using inflammable gases; this could cause an explosion and put operator safety at risk.

REMOVAL AND RE-FITTING

- Lift and handle all heavy parts using suitable lifting equipment and make sure that all slings and hooks are correctly secured.
- Handle all parts carefully during lifting operations, keep an eye on the personnel working near the load to be lifted. Never insert hands or fingers between parts, always wear approved accident prevention clothing (goggles, gloves and work boots).
- Avoid twisting chains or metal cables and always wear safety gloves when handling cables or chains.

Personal safety CAB AIR CONDITIONING SYSTEM

T4.105F With cab [ZDJD11527 -]	NA
T4.75F With cab [ZDJD10166 -]	NA
T4.85F With cab [ZDJD11099 -]	NA
T4.95F With cab [ZDJD10640 -]	NA

SAFETY REGULATIONS

- The refrigerant must be handled with great care in order to avoid personal injury; always use safety goggles and gloves.
- Liquid refrigerant can cause freezing of the skin and serious damage to the eyes, sometimes resulting in permanent blindness.
- Keep the refrigerant container away from heat sources. Heat will cause an increase in pressure of the refrigerant and could cause the container to explode.
- If refrigerant comes into contact with a naked flame or a hot metal surface it produces a toxic gas, which is dangerous if inhaled.
- In order to avoid accidents follow the simple precautions described below.
- The operation of emptying and charging the system must be carried out in a well-ventilated area, well away from any naked flames.
- During the charging and emptying operations, take the necessary precautions to protect the face and above all the eyes from accidental contact with refrigerant.
- In the event of an accident, proceed as follows:
 - if refrigerant splashes into the eyes, wash immediately with a few drops of mineral oil, then wash them thoroughly with a solution of boric acid and water (one spoonful of acid in 1/4 cup of water) and seek medical assistance immediately.
 - freezing of the skin caused by contact with liquid refrigerant may be treated by gradually warming the injured area with cold water, followed by the application of a greasy cream. Request medical assistance.
 - the air conditioning system contains a mixture of refrigerant and oil under high pressure; under no circumstances loosen pipe fittings/unions or work on the pipes without having first drained the system.
 - do not loosen or remove the compressor oil level check cap with the system pressurized.
 - do not heat the refrigerant container. If the temperature exceeds **50 °C (122.00 °F)** the pressure will increase very rapidly.
 - keep the air conditioning system away from heat sources to prevent explosions as a result of an increase in pressure in the system piping.
- When transferring refrigerant from one container to another, only use homologated liquid refrigerant containers equipped with safety valves.
- Never fill liquid refrigerant containers over **80 % (80.0 %)** of their maximum capacity.
- Do not modify the settings of safety valves and the control devices.
- Never connect the recovery/recycling and evacuation/charging stations to electrical power outlets with voltages other than those specified; do not leave the stations powered up unless they are to be used immediately.

Basic instructions

Battery

Before carrying out any kind of service operation disconnect and isolate the battery negative lead, unless otherwise requested for specific operations (e.g: operations that require the engine running). Once the specific operation has been completed, disconnect the lead in order to complete the operation.

Shimming

For each adjustment operation, select adjusting shims and measure individually using a micrometer, then add up the recorder values: Do not rely on measuring the entire shimming set, which may be incorrect, or the rated value indicated for each on shim.

Rotating shaft seals

For correct rotating shaft seal installation, proceed as follows:

- Before assembly, allow the seal to soak in the oil it will be sealing for at least thirty minutes.
- Thoroughly clean the shaft and check that the working surface on the shaft is not damaged.
- Position the sealing lip facing the fluid; with hydrodynamic lips, take into consideration the shaft rotation direction and position the grooves so that they will deviate the fluid towards the inner side of the seal.
- Smear the sealing lip with a thin layer of lubricant (use oil rather than grease) and fill the gap between the sealing lip and the dust lip on double lip seals with grease.
- Insert the seal in its seat and press down using a flat punch; do not tap the seal with a hammer or mallet.
- Whilst inserting the seal, check that it is perpendicular to the seat; once settled, make sure that it makes contact with the thrust element, if required.
- To prevent damaging the seal lip on the shaft, position a protective guard during installation operations.

O-ring seals

Lubricate the O-ring seals before inserting them in the seats, this will prevent them from overturning and twisting, which would jeopardise sealing efficiency.

Sealing compounds

Apply one of the following sealing compounds on the mating surfaces marked with an X: **LOCTITE® 518™** , **LOCTITE® 5205**.

Before applying the sealing compound, prepare the surfaces as follows:

- Remove any incrustations using a wire brush.
- Thoroughly de-grease the surfaces using one of the following cleaning agents: trichlorethylene, petrol or a water and soda solution.

Bearings

When installing bearings it is advised to:

- Heat the bearings to **80 - 90 °C** before fitting on the shafts.
- Allow the bearings to cool before installing them from the outside.

Spring pins

When fitting split socket elastic pins, ensure that the pin notch is positioned in the direction of the force required to stress the pin.

Spiral spring pins do not require special positioning.

Spare parts

Use genuine parts only.

Only genuine spare parts guarantee the same quality, duration and safety as they are the same parts that are assembled during production.

Only genuine parts can offer this guarantee.

When ordering spare parts, always provide the following information:

- Tractor model (commercial name) and frame number.
- Engine type and number.
- Part number of the ordered part, which can be found in the "Spare Parts Catalogue" used for order processing.

Notes for equipment

The tools that NEW HOLLAND propose and illustrate in this manual are:

- Specifically researched and designed for use with NEW HOLLAND vehicles.
- Necessary to make reliable repair.
- Accurately built and strictly tested to offer efficient and long-lasting working means

By using these tools, repair personnel will benefit from:

- Operating in optimal technical conditions.
- Obtaining the best results.
- Saving time and effort;
- Working in safe conditions.

Important notes

Wear limit values indicated for certain parts are recommended, but not binding. The terms "front", "rear", "right-hand" and "left-hand" (when referred to different parts) are intended as seen from the driving position with the tractor in the normal direction of movement.

Moving the tractor with the battery removed

External power supply cables should only be connected to the respective positive and negative cable terminals, using efficient clamps that guarantee adequate and secure contact.

Disconnect all services (lights, windshield wipers, etc.) before starting the vehicle.

If the vehicle electrical system requires checking, carry out operations with the power supply connected; Once checking is completed, disconnect all services and switch off the power supply before disconnecting the cables.

Consumables

Component to be filled or topped up	Qty.	Recommended NEW HOLLAND products	NEW HOLLAND specifications	International specifications
Cooling system: Less cab With cab	10.5 l (2.77 US gal) 13.5 l (3.57 US gal)	Water and NEW HOLLAND AMBRA AGRIFLU liquid 50% + 50%	NH900A	-
Windscreen washer reservoir	2 l (0.53 US gal)	Water and cleaning fluid	-	-
Fuel tank: Tank Reduced tank	77 l (20.34 US gal) 67 l (17.7 US gal)	Decanted and filtered diesel fuel	-	-
Engine oil sump: T4030F and T4040F T4050F and T4060F	8.5 l (2.25 US gal) 9.5 l (2.51 US gal)	NEW HOLLAND AMBRA SUPER GOLD 15W-40 NEW HOLLAND AMBRA AUTO SUPREME 10W-30	NH 330H SAE 15W-40 NH 324H SAE 15W-40	API CH-4 ACEA E7/E5
Brake circuit	0.5 l (0.13 US gal)	NEW HOLLAND AMBRA BRAKE LHM	NH610A	ISO 7308
With front brakes	0.2 l (0.05 US gal)			
Front axle: Housing casing Final drives without brakes (each) Final drives with brakes (each)	2.8 l (0.74 US gal) 1.0 l (0.26 US gal) 1.75 l (0.46 US gal)	NEW HOLLAND AMBRA MULTI G 134™ HYDRAULIC TRANSMISSION OIL	NH410B	API GL-4 ISO 32/46 SAE 10W30 API GL-5 MIL-L-2105D SAE 80W - 90
Rear transmission (bevel drive, final drives and brakes), gearbox, hydraulic lift, P.T.O. and hydraulic steering	44 l (11.62 US gal)			
Grease fittings	-	NEW HOLLAND AMBRA GR-9 MULTI-PURPOSE GREASE	NH710A	NLGI 2

Consumables

Component to be filled or topped up	Qty.	Recommended NEW HOLLAND products	NEW HOLLAND Specifications	International specifications
Cooling system: Less cab With cab	10.5 l (2.77 US gal) 13.5 l (3.57 US gal)	Water and NEW HOLLAND AMBRA AGRIFLU liquid 50% + 50%	NH900A	–
Windscreen washer reservoir	2 l (0.52 US gal)	Water and cleaning fluid	–	–
Fuel tank: Tank Reduced tank	77 l (20.34 US gal) 67 l (17.7 US gal)	Decanted and filtered diesel fuel	–	–
Engine oil sump: T4030F and T4040F T4050F and T4060F	8.5 l (2.25 US gal) 9.5 l (2.51 US gal)	NEW HOLLAND AMBRA SUPER GOLD 15W-40 NEW HOLLAND AMBRA AUTO SUPREME 10W-30	NH330H) (SAE 15W - 40) NH324H) (SAE 15W - 40)	API CH-4 ACEA E7/E5
Brake circuit With front brakes	0.5 l (0.13 US gal) 0.2 l (0.05 US gal)	NEW HOLLAND AMBRA BRAKE LHM	NH610A	ISO 7308
Front axle: Housing casing Final drives without brakes (each) Final drives with brakes (each)	2.8 l (0.73 US gal) 1.0 l (0.26 US gal) 1.75 l (0.46 US gal)	NEW HOLLAND AMBRA MULTI G™ HYDRAULIC TRANSMISSION OIL	NH410B	API GL-4 ISO 32/46 SAE 10W30 API GL-5 MIL-L-2105D SAE 80W90
Rear transmission (bevel drive, final drives and brakes), gearbox, hydraulic lift, P.T.O. and hydraulic steering:	44 l (11.62 US gal)			
Grease fittings	–	NEW HOLLAND AMBRA GR-9 MULTI-PURPOSE GREASE	NH710A	NLGI 2



SERVICE MANUAL

Engine

T4.105F With cab [ZDJD11527 -], T4.105F Without cab [ZDJD11911 -], T4.75F With cab [ZDJD10166 -], T4.75F Without cab [ZDJD10836 -], T4.85F With cab [ZDJD11099 -], T4.85F Without cab [ZDJD11022 -], T4.95F With cab [ZDJD10640 -], T4.95F Without cab [ZDJD10215 -]

Contents

Engine - 10

[10.001] Engine and crankcase	10.1
-------------------------------------	------



Engine - 10

Engine and crankcase - 001

T4.105F With cab [ZDJD11527 -], T4.105F Without cab [ZDJD11911 -], T4.75F With cab [ZDJD10166 -], T4.75F Without cab [ZDJD10836 -], T4.85F With cab [ZDJD11099 -], T4.85F Without cab [ZDJD11022 -], T4.95F With cab [ZDJD10640 -], T4.95F Without cab [ZDJD10215 -]

Contents

Engine - 10

Engine and crankcase - 001

SERVICE

Engine	
and crankcase - Remove	3
Install	9

Engine and crankcase - Remove

⚠ DANGER

Heavy objects!

Lift and handle all heavy components using lifting equipment with adequate capacity. Always support units or parts with suitable slings or hooks. Make sure the work area is clear of all bystanders.

Failure to comply will result in death or serious injury.

D0076A

ATTENTION: Use suitable tools to align the holes. Never use fingers or hands.

1. Remove the cab as described in operation **Cab - Remove (90.100)**.
2. Extract the fixing pin and remove the ballast (1), unscrew the retaining screws and retrieve the ballast support (2).

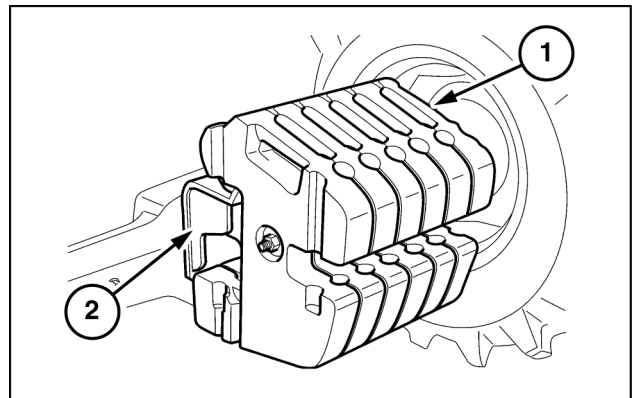

MOL111F0001AB 1

3. Position and secure the bracket **380001613 (1)** complete with spacers **50162 (4)** on the front axle **(3)** and the related support **(2)**.

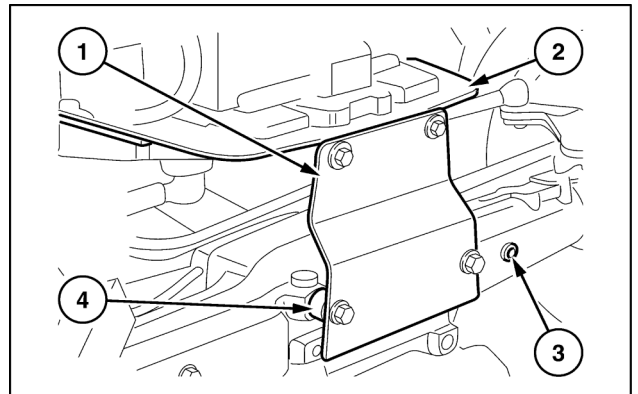

MOL111F0002AB 2

4. Unscrew the plug and drain the oil from the rear transmission casing (the prescribed quantity is **42 l**).

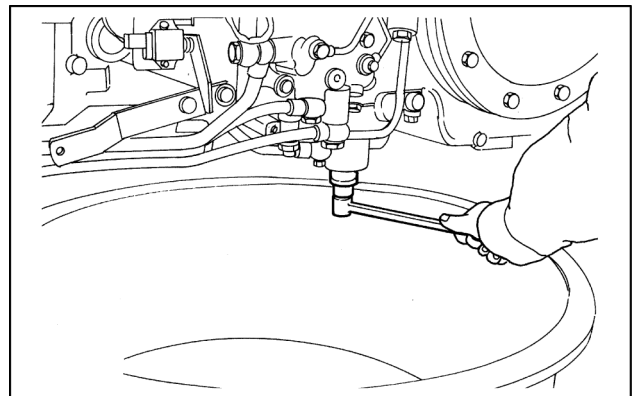

MOL111F0003AA 3

5. Disconnect the pipes **(1)** and **(2)** of the transmission oil cooler and of the front axle differential lock.

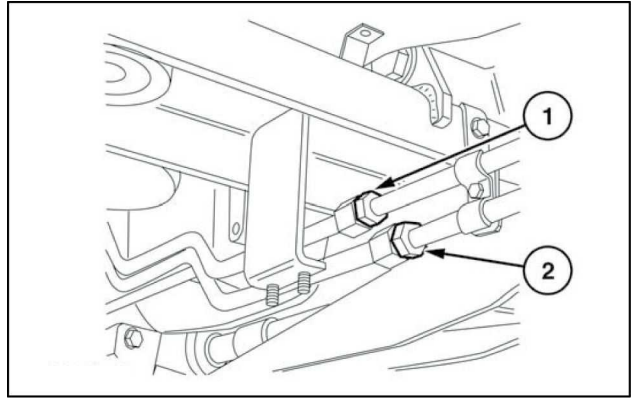

MOLI11F0004AB 4

6. Unscrew the front and rear retaining bolts, unscrew the front pivot pin retaining screw and remove the bracket **(1)**.
Unscrew the relative retaining bolts and remove the rear guard.

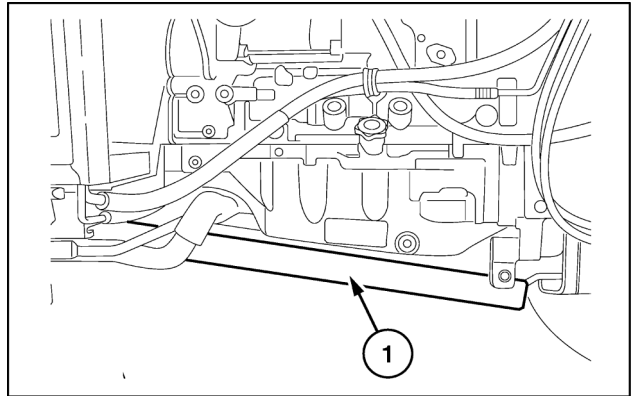

MOLI11F0005AB 5

7. Remove the circlip **(2)** and move the front sleeve **(1)** backwards in order to free it from the groove on the front axle.

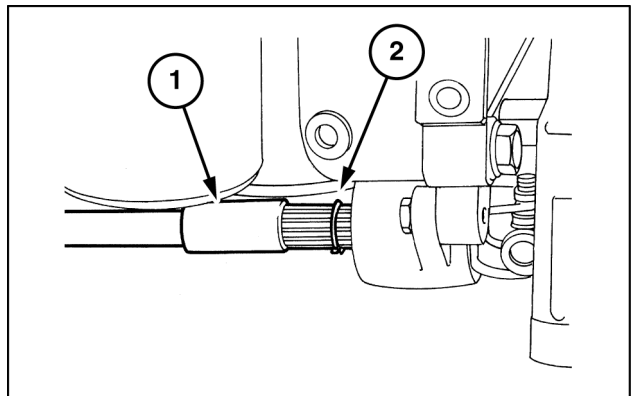

MOLI11F0006AB 6

8. Remove the circlip **(2)** and move the rear sleeve **(1)** in order to release it from the groove on the drive.

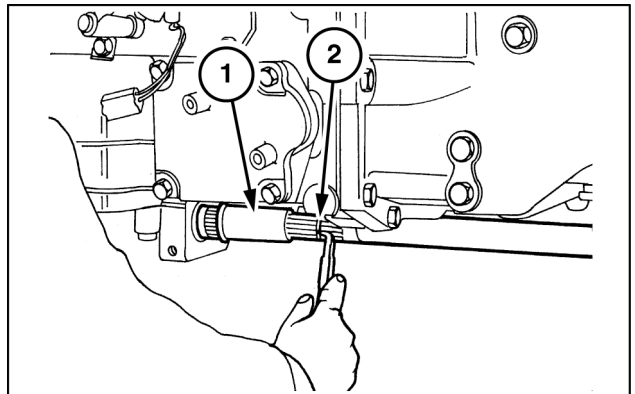

MOLI11F0007AB 7

9. Unscrew the transmission shaft central support **(1)** retaining bolts and remove the shaft and support.

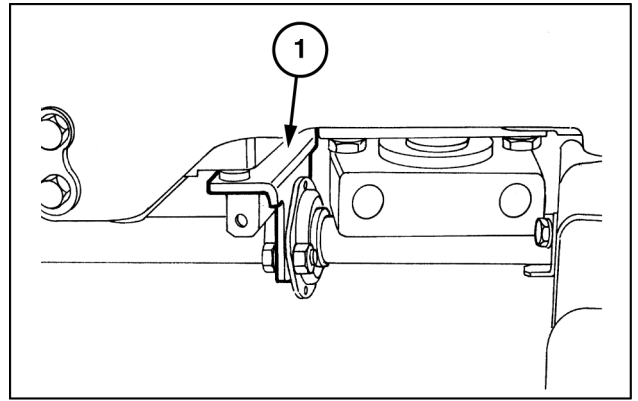

MOL111F0008AB 8

10. Disconnect: The transmission oil cooler pipes **(1)** and the front axle differential lock pipe **(2)**.

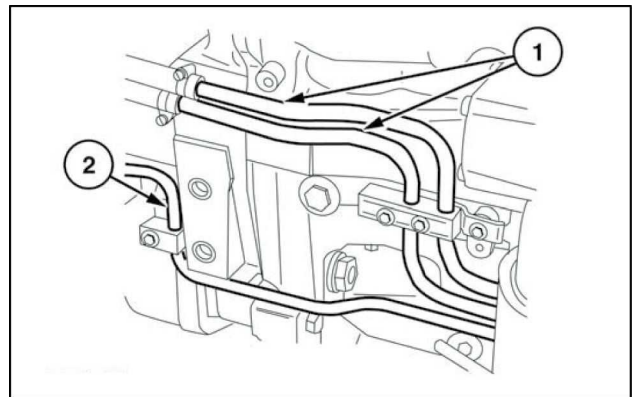

MOL111F0009AB 9

11. Unscrew: The retaining bolts of the pipe **(1)** delivering oil to the pump and the bolts retaining the pipe **(2)** to the filter support.

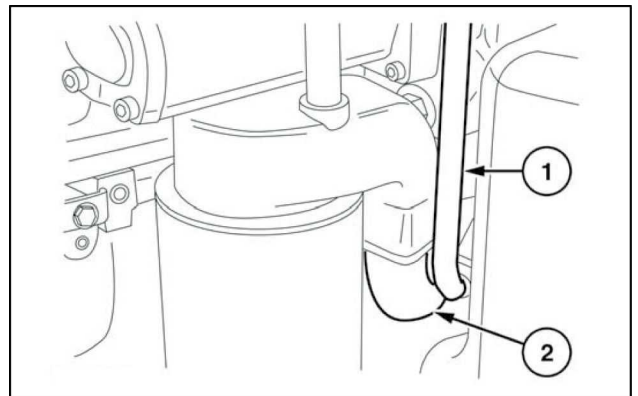

MOL111F0010AB 10

12. Loosen the related clamps and remove the sleeve **(2)** from the pipe **(1)** and remove the transmission oil inlet pipe together with the above-mentioned sleeve.

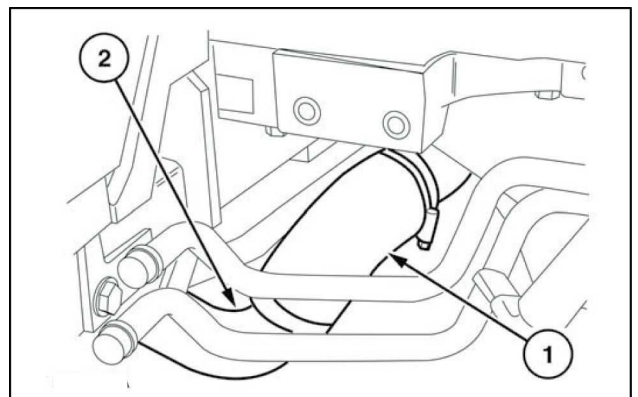

MOL111F0011AB 11

13. Unscrew the fixing clamps and disconnect the pipes **(1)** and **(2)** from the cooler, the sleeve **(4)** between the air filter and the turbocharger and the oil vapor recirculation pipe **(3)**.

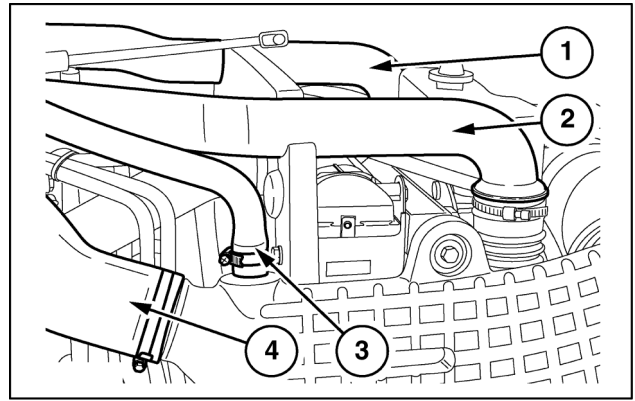

MOL11F0012AB 12

14. Disconnect the secondary tank fuel level connection **(1)** and the clogged air filter pressure switch connection.

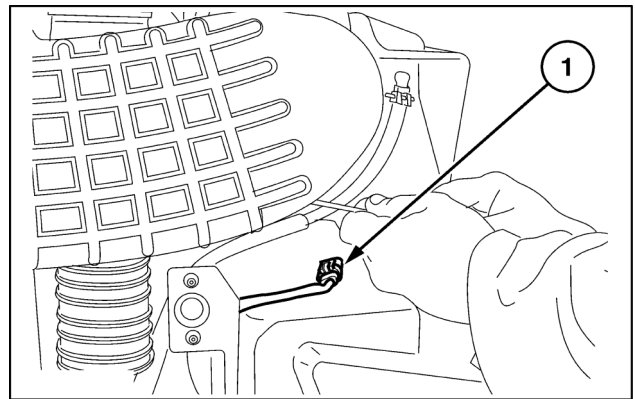

MOL11F0013AB 13

15. Disconnect the steering hydraulic cylinder control pipes **(1)**.

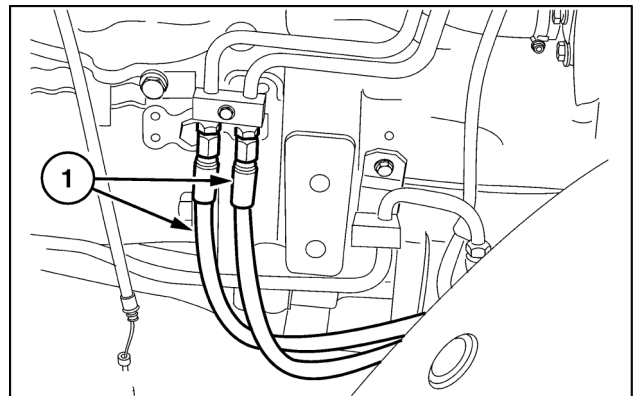

MOL11F0014AB 14

16. Unscrew the fixing clamps and detach the upper **(1)** and lower **(2)** sleeves from the engine radiator.

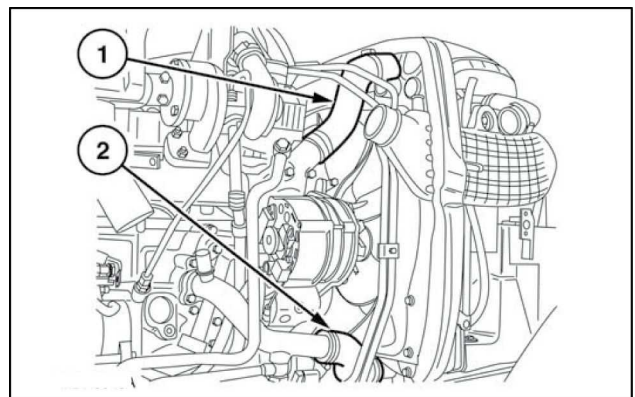

MOL11F0015AB 15

17. Unhook the catch and extract the transmission oil radiator (1).

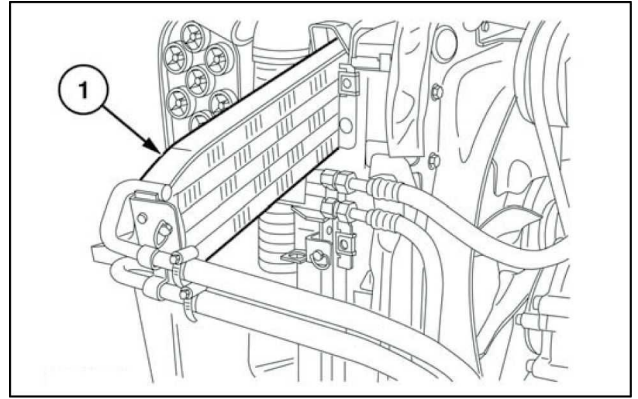

MOL111F0016AB 16

18. Disconnect the pipes (1) of the air-conditioning system from the related condenser.

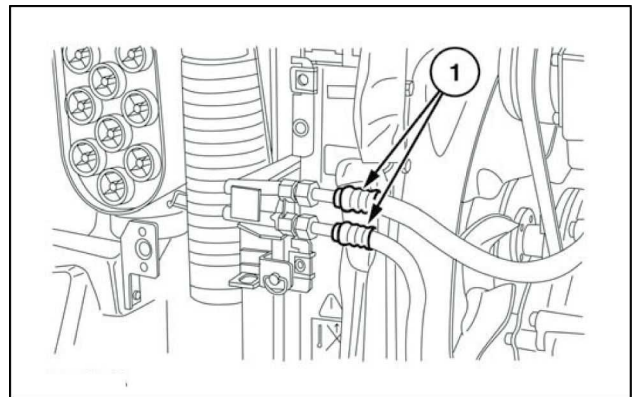

MOL111F0017AB 17

19. Unscrew the fixing screws and remove the guard (1), unscrew the fixing screw (2), loosen the related clamp and detach the pipe (3) joining the main tank to the secondary one.

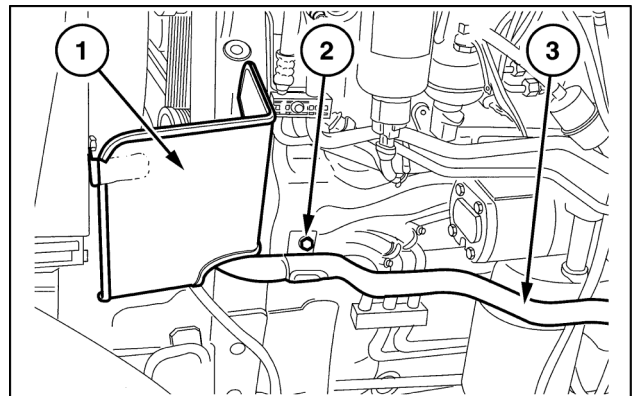

MOL111F0018AB 18

20. Unscrew the fixing screw and detach the bracket (1) locking the engine radiator.

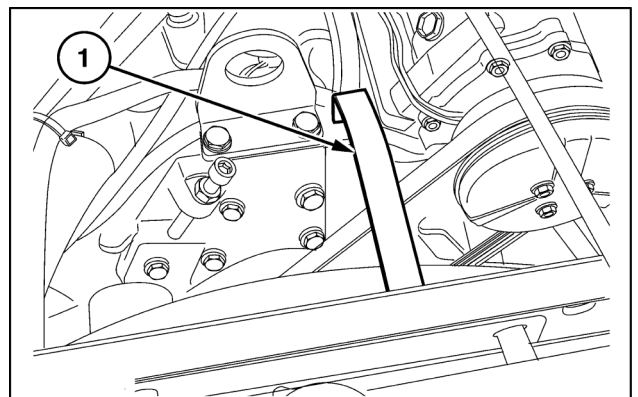

MOL111F0019AB 19

21. Position a fixed stand under the transmission-clutch casing.
22. Connect the engine to the hoist using a chain and make it take up the strain.
23. Unscrew the bolts **(1)** securing the engine to the transmission-clutch casing and detach the engine assembly and front axle.

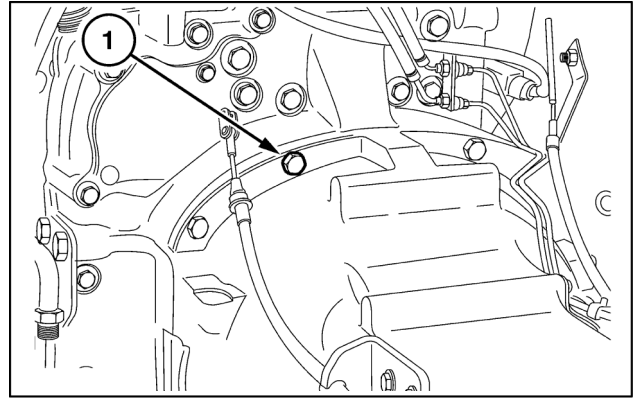

MOL11F0020AB 20

24. Set up two fixed stands: One under the axle support at the rear and the other under the front side.
25. Unscrew the bolts **(1)** on both sides and separate the engine from the axle-support assembly with the radiators.
26. Rest the engine on an adequate support.

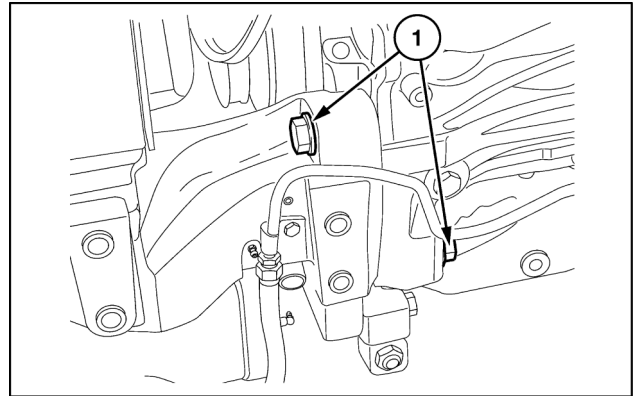

MOL11F0021AB 21

Engine - Install

▲ CAUTION

Pinch hazard!

Always use suitable tools to align mating parts.

DO NOT use your hand or fingers.

Failure to comply could result in minor or moderate injury.

C0044A

- Respect the tightening torques as prescribed.
- Connect the engine, with chains, to the hoist.
- Refit the engine to the front axle-support assembly with the radiator and cooler.
- Before refitting the engine to the clutch box carefully clean the mating surfaces and apply sealing compound (**0.002 m** diameter), according to the diagram **Transmission drive housing - Reseal (21.114)**.
- Position the engine on the clutch casing and secure it with the specific bolts.
- Position and secure the retaining bracket between the radiator and engine.
- Secure the pipe joining the main tank to the secondary one.
- Position and secure the guard between the radiator and engine.
- Connect the air-conditioning system pipes to the condenser.
- Insert the transmission oil radiator into its seat and secure it.
- Connect and secure the top and bottom sleeves to the engine radiator.
- Connect the steering cylinder control piping.
- Connect the electrical connections of the secondary tank fuel level and clogged air filter.
- Position and secure the connecting pipes of the cooler, turbocharger, air filter and oil vapour recirculation.
- Position and connect the transmission oil inlet pipe.
- Position and secure the pipes of the transmission oil filter support.
- Connect the transmission oil cooler and front axle differential lock pipes.
- Position the propeller shaft, secure the central support, slide the two front and rear sleeves and secure them with the circlips.
- Position the propeller shaft front bracket and secure it.

- Position and secure the propeller shaft rear guard.
- Connect the cooler and front axle differential lock pipes.
- Unscrew the retaining bolts and remove the bracket **380001613** with the spacers 50612.
- For models fitted with brakes on the front axle it is necessary to fill the relevant tank **Consumables ()/ Consumables ()** for the prescribed product and quantity) and bleed the braking system (**Brake lines - Bleed (33.202)**).
- Screw the plug on the rear transmission casing and fill up with oil (see **Consumables ()/ Consumables ()** for the prescribed product and quantity).
- Position and secure the ballast support.
- Position and secure the ballast.
- Install the cab as described in operation **Cab - Remove (90.100)**.

Index

Engine - 10

Engine and crankcase - 001

Engine - Install	9
Engine and crankcase - Remove	3



© 2016 CNH Industrial Italia S.p.A.

All rights reserved. No part of the text or illustrations of this publication may be reproduced.

NEW HOLLAND policy is one of continuous improvement and the right to change prices, specification or equipment at any time without notices is reserved.

All data given in this publication is subject to production variations. Dimensions and weight are approximate only and the illustrations do not necessarily show products in standard condition. For exact information about any particular product, please consult your NEW HOLLAND Dealer.



SERVICE MANUAL

Clutch

T4.105F With cab [ZDJD11527 -], T4.105F Without cab [ZDJD11911 -], T4.75F With cab [ZDJD10166 -], T4.75F Without cab [ZDJD10836 -], T4.85F With cab [ZDJD11099 -], T4.85F Without cab [ZDJD11022 -], T4.95F With cab [ZDJD10640 -], T4.95F Without cab [ZDJD10215 -]

Contents

Clutch - 18

[18.104] Clutch hydraulic release control.....	18.1
[18.110] Clutch and components	18.2
[18.100] Clutch mechanical release control	18.3



Clutch - 18

Clutch hydraulic release control - 104

T4.105F With cab [ZDJD11527 -], T4.105F Without cab [ZDJD11911 -], T4.75F With cab [ZDJD10166 -], T4.75F Without cab [ZDJD10836 -], T4.85F With cab [ZDJD11099 -], T4.85F Without cab [ZDJD11022 -], T4.95F With cab [ZDJD10640 -], T4.95F Without cab [ZDJD10215 -]

Contents

Clutch - 18

Clutch hydraulic release control - 104

SERVICE

Clutch hydraulic release control	
Alignment	3
Travel adjust	5

Clutch hydraulic release control - Alignment

Coplanarity adjustment of 11"/11" dual clutch release

1. After overhauling the clutch, fit centering pin **380001612 (1)** and fit the clutch assembly on the flywheel tightening the fixing screws **(2)**.

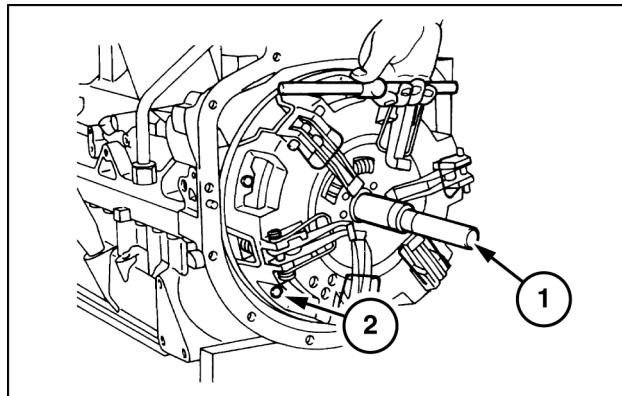

MOL111F0064AB 1

2. Insert the gauge **380000293 (1)** on the centering pin and, using a feeler gauge, adjust the main clutch release levers **(2)** to obtain a clearance of **0.1 mm**.

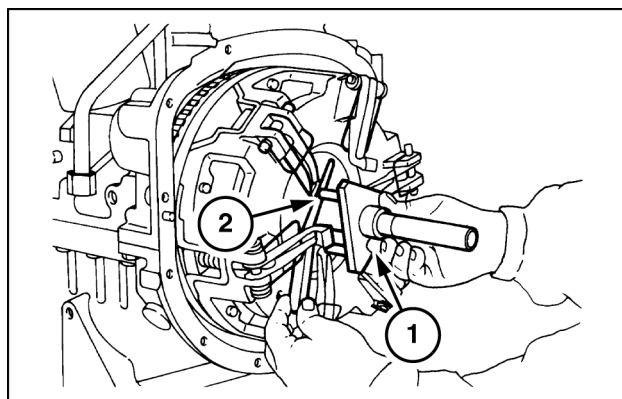

MOL111F0065AB 2

3. Turn the gauge **380000293 (1)** and, using a feeler gauge, adjust the P.T.O. clutch release levers **(2)** to obtain a clearance of **0.1 mm**.

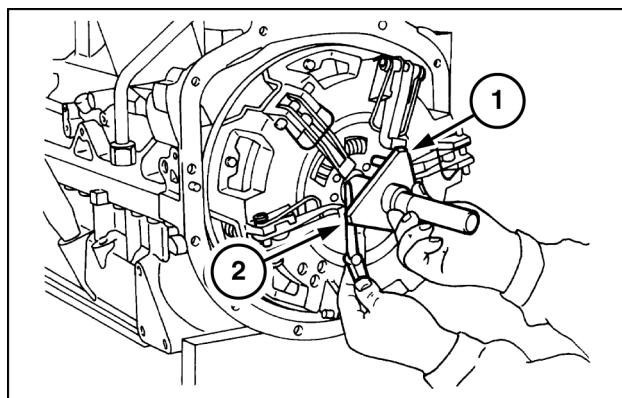

MOL111F0066AB 3

Coplanarity of 11" single plate clutch release levers

4. After overhauling the clutch, fit centering pin **380001612 (1)**, the gauge **380000293 (2)**, and fit the clutch assembly on the flywheel tightening the fixing screws **(3)**.

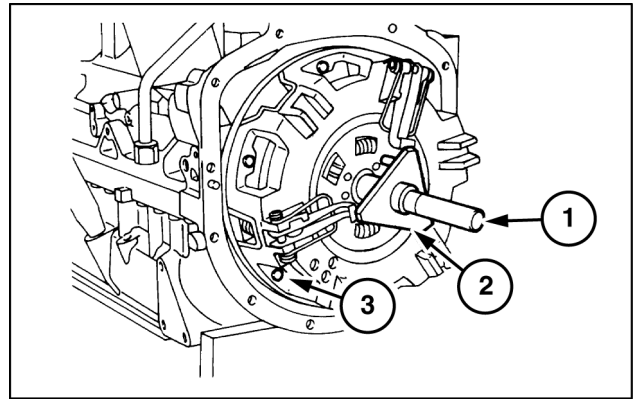

MOLI11F0067AB 4

5. Using a feeler gauge, adjust the coplanarity of the clutch release lever to obtain a clearance of **0.1 mm**.

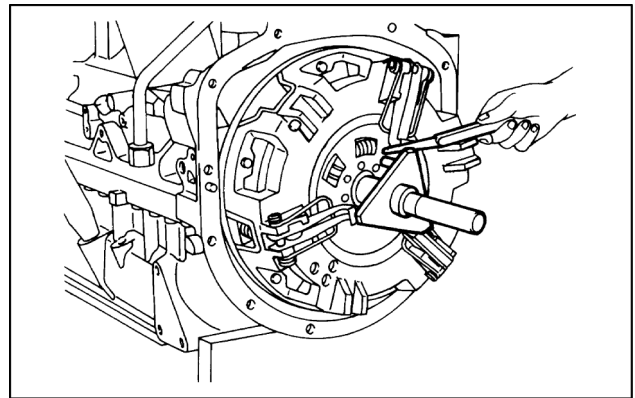

MOLI11F0068AA 5

Clutch hydraulic release control - Travel adjust

Main clutch adjustments

- If the position of the clutch pedal (1) requires adjustment, or after a clutch overhaul, check that main clutch pedal travel (A) is **148 - 152 mm** for tractors without a cab or **158 - 162 mm** for tractors with a cab. If not adjust as follows:

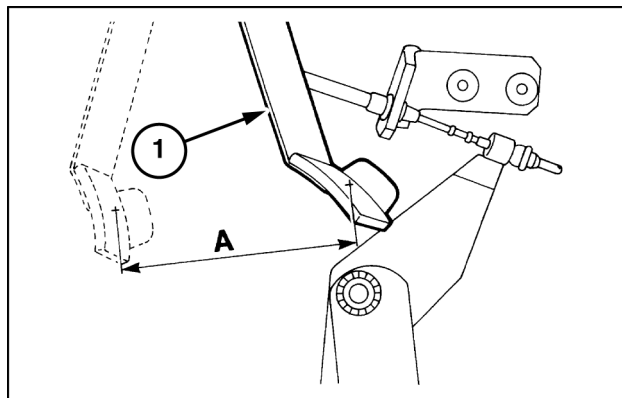

MOL111F0069AB 1

- Loosen the locknut (2) and turn the nut (1) anti-clockwise.
- Check that pedal travel is **148 - 152 mm** or **158 - 162 mm**.
- Tighten the locknut (1).

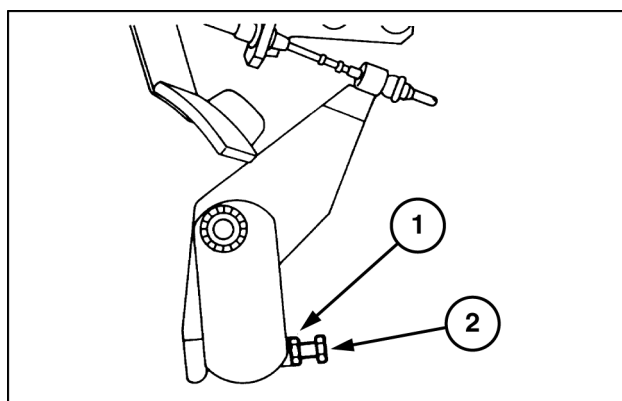

MOL111F0070AB 2

- Operate the unit four or five times.
- Check that the clutch pedal (1) travel is as prescribed.
- If necessary, reset to the correct value (A), as previously described.
- After having correctly adjusted pedal travel, check that the entire distance is travelled with a maximum load of **19 daN (42.71 lbf)**.

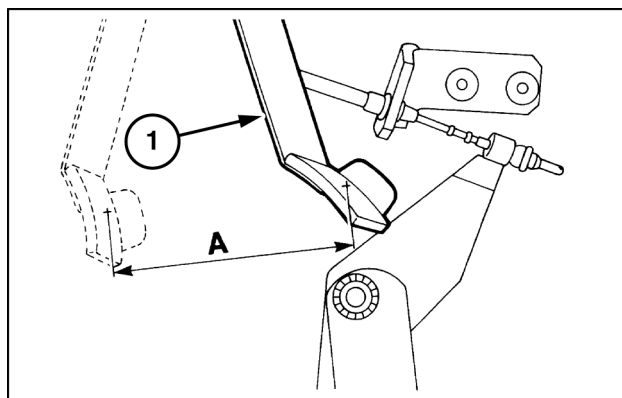

MOL111F0071AB 3

Index

Clutch - 18

Clutch hydraulic release control - 104

Clutch hydraulic release control - Alignment	3
Clutch hydraulic release control - Travel adjust	5



Clutch - 18

Clutch and components - 110

T4.105F With cab [ZDJD11527 -], T4.105F Without cab [ZDJD11911 -], T4.75F With cab [ZDJD10166 -], T4.75F Without cab [ZDJD10836 -], T4.85F With cab [ZDJD11099 -], T4.85F Without cab [ZDJD11022 -], T4.95F With cab [ZDJD10640 -], T4.95F Without cab [ZDJD10215 -]

Contents

Clutch - 18

Clutch and components - 110

TECHNICAL DATA

Clutch	
General specification	3
Torque	3
Special tools	4

FUNCTIONAL DATA

Clutch	
Sectional view	5

SERVICE

Clutch	
Remove	6
Install	7
Overhaul	8
Overhaul	12
Resurface - Checks, measurements and repairs - dual disk clutch	13

DIAGNOSTIC

Clutch	
Troubleshooting	15

Clutch - General specification

Luk 11"/11" clutch – general specifications

Type Mechanical	Single disk, dry plate dual clutch unit Operation: Pedal operated main transmission clutch; hand lever operated P.T.O. clutch Belleville spring disk Spiral springs
Engagement and release mechanism P.T.O. clutch engagement and release mechanism	
Driven plate lining material for main transmission clutch: Driven plate lining material for P.T.O. clutch Driven plate thickness: Main clutch (9), (Clutch - Sectional view (18.110) Figure 1) P.T.O. clutch (11), (Clutch - Sectional view (18.110) Figure 1) Wear limit	Cerametallic 9.6 - 10.4 mm (0.37795 - 0.4094 in) 7.3 - 7.9 mm (0.2874 - 0.3110 in) See Engage and release control tie rod - Adjust (31.101) and Engage and release control tie rod - Sectional view (31.101)
Clearance between main transmission clutch release sleeve and housing Clearance between P.T.O. clutch release sleeve and housing	0.050 - 0.151 mm (0.0020 - 0.0059 in) 0.060 - 0.136 mm (0.0024 - 0.0054 in)
Release lever coplanarity adjustment	See Engage and release control tie rod - Sectional view (31.101)
Clutch control adjustment	See Engage and release control tie rod - Dynamic description (31.101)

Luk 11" clutch – general specifications

Type Mechanical	Single dry plate clutch Operation with pedal Spiral springs
Engagement and release mechanism	
Driven plate lining material for P.T.O. clutch Driven plate thickness for P.T.O. clutch (1), (Clutch - Sectional view (18.110) Figure 2) Driven plate wear limit	Cerametallic pads 7.3 - 7.9 mm (0.2874 - 0.3110 in) See Engage and release control tie rod - Adjust (31.101)
Clearance between clutch release sliding sleeve and support	0.050 - 0.151 mm (0.0020 - 0.0059 in)

Clutch - Torque

Tightening torques

Parts to be tightened	Thread	Tightening torque
11 in/11 in clutch/flywheel retaining bolts	M8 x 1.25	20 - 25 N·m (15 - 18 lb ft)
Release command fork securing bolt (7), (Clutch - Sectional view (18.110) Figure 1)	M16 x 1.5	136 - 165 N·m (100 - 122 lb ft)
Clutch casing/engine retaining nuts (3), (Clutch - Sectional view (18.110) Figure 1)	M12 x 1.25	117 - 129 N·m (86 - 95 lb ft)
Nut for sleeve cover fixing stud (6), (Clutch - Sectional view (18.110) Figure 1)	M8 x 1.25	20 - 25 N·m (15 - 18 lb ft)

Clutch - Special tools

Tools

NOTICE: *The operations described in this section must only be performed with the ESSENTIAL tools marked with an (X). To work safely and efficiently and obtain the best results, it is also necessary to use the recommended specific tools listed below and certain other tools, which are to be made according to the drawings included in this manual.*

List of specific tools required for the various operations described in this section

- 380000236 Tractor disassembly trolley
- X 380001760 Pin for centring and adjustment of
11 in/ 11 in clutches
- X **380000293** Clutch adjustment gauge (with
294073)
- 380000256** Set of wrenches for adjustment of
levers in **11 in/ 11 in** LUK clutches
- X **380001613** Axle-engine support bracket

Clutch - Sectional view

Longitudinal section of LUK 11"/11" clutch

1. P.T.O. clutch release lever adjuster
2. Belleville spring
3. Bolts and nuts securing clutch casing to the engine
4. Power take-off clutch disengagement levers
5. Release sleeves for main and P.T.O. clutch, complete with thrust bearings
6. Nuts for sleeve cover studs
7. Fork lever retaining bolts
8. Main transmission clutch release levers
9. Main transmission clutch plate
10. Main transmission clutch release lever adjuster
11. Power take-off clutch disk
12. Bearing on flywheel

$D = 97.5 \text{ mm (3.8385 in)}$. Nominal distance of release levers (8) from clutch contact surface on flywheel.

$D_1 = 139.5 \text{ mm (5.4921 in)}$. Nominal distance of release levers (4) from clutch contact surface on flywheel.

NOTE: When assembling apply sealing compound on surfaces marked with an X as shown in **Transmission housing - Reseal (21.114)**.

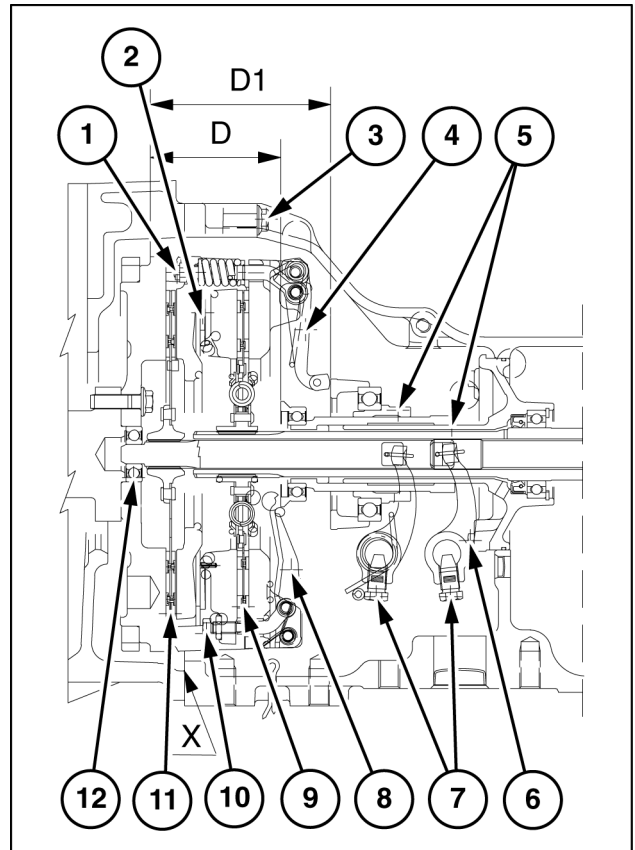

MOL111F0043BB 1

Longitudinal section of 11" LUK clutch

1. Main transmission clutch plate
2. Power take-off clutch disengagement levers

$D_1 = 139.5 \text{ mm (5.4921 in)}$. Nominal distance of release levers (2) from clutch contact surface on flywheel.

NOTICE: When refitting the clutch, check that the clutch disks are positioned as in the drawing.

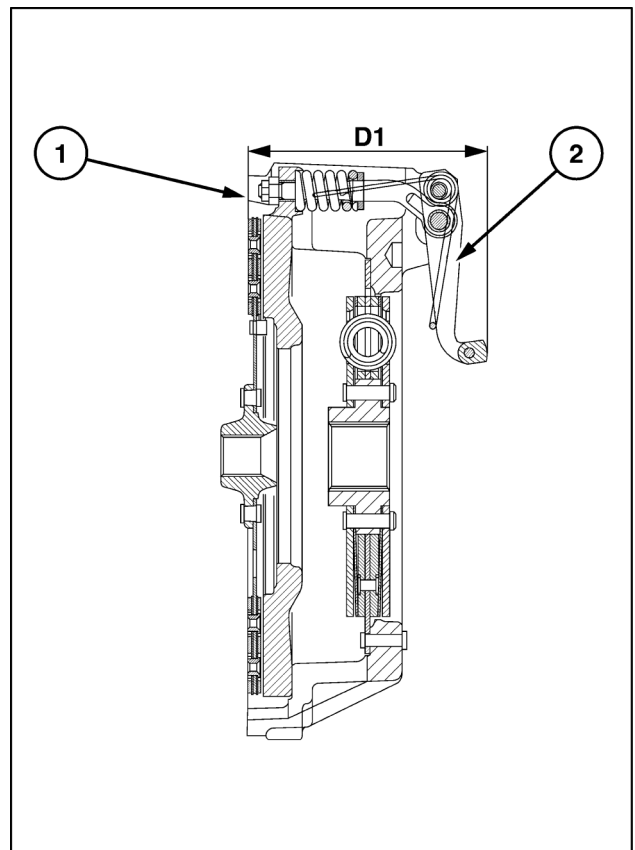

MOL111F0044BB 2

Clutch - Remove

Proceed as follows:

1. Remove the cab as described in **Cab - Remove (90.100)**.
2. Remove the engine, as far as **Engine and crankcase - Remove (10.001) Instruction 23**.
3. Unscrew the retaining screws and remove the clutch (**1**).

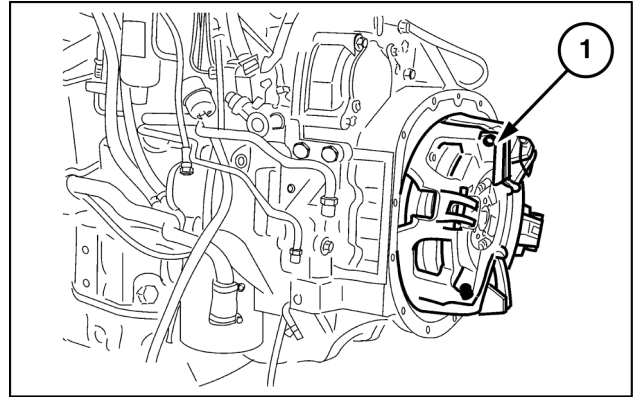

MOL111F0045AB 1

Clutch - Install

To refit the clutch proceed as follows:

- Position the clutch and secure it.
- Install the engine assembly as described in **Engine and crankcase - Remove (10.001)**.
- Install the cab as described in **Cab - Remove (90.100)**.

Clutch - Overhaul

11"/11" Dual disk clutch-test bench overhaul

Proceed as follows:

1. Unscrew the three P.T.O. clutch lever adjustment nuts (1).

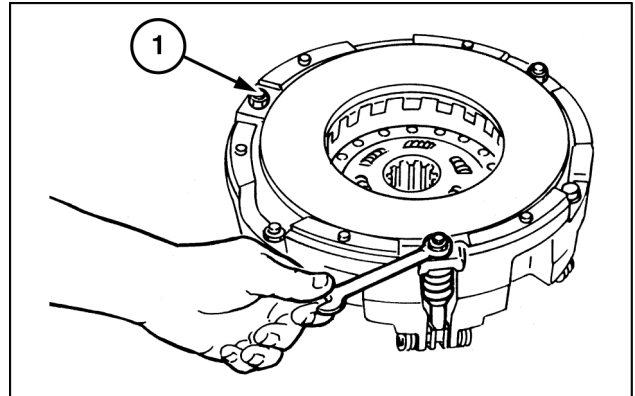

MOLI11F0046AB 1

2. Recover the pressure plate (1) with the three coil springs (2) and the three washers.

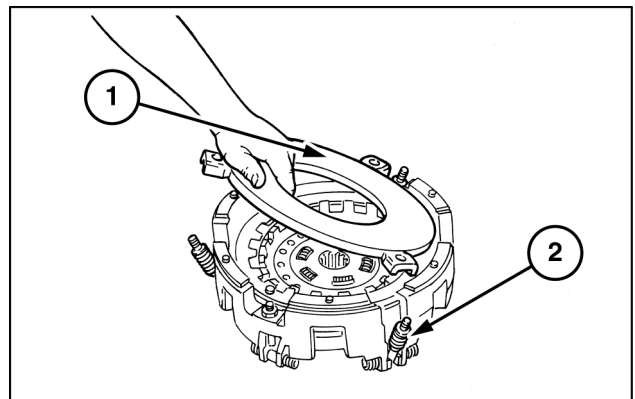

MOLI11F0047AB 2

3. Position three clamps (1) at intervals of 120° on the clutch body and gradually and carefully squeeze the belleville spring disk.

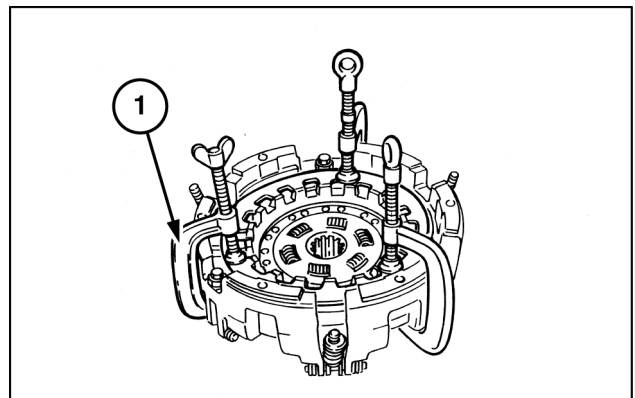

MOLI11F0048AB 3

4. Extract the six spring retaining pins (1) from their seats.

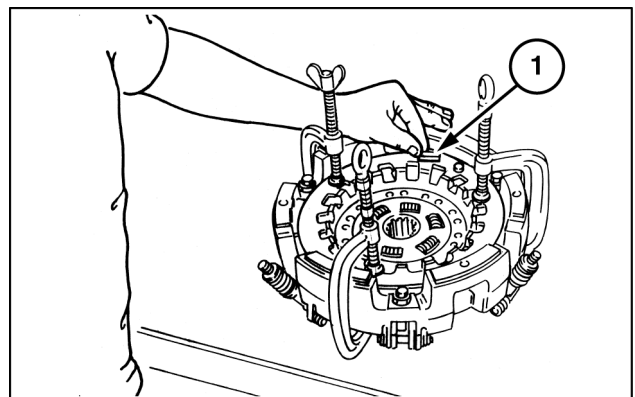

MOLI11F0049AB 4

5. Remove the three clamps and extract the belleville spring disk **(1)**.

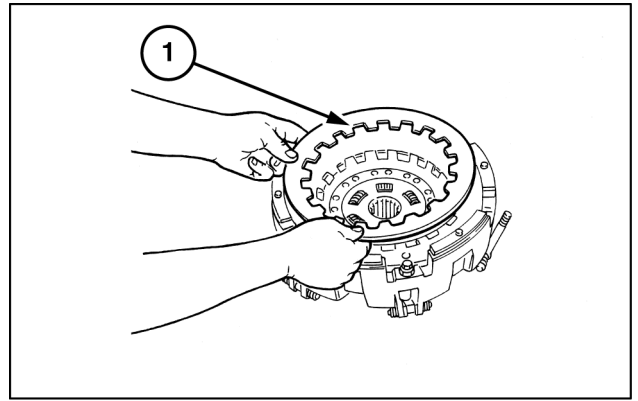

MOL111F0050AB 5

6. Loosen the three locknuts **(1)** on the main clutch lever adjustment screws.

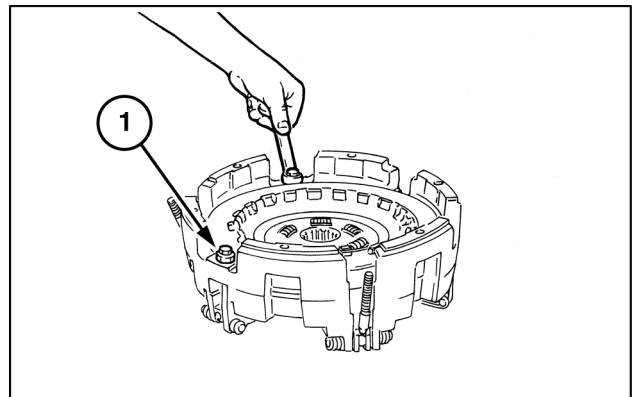

MOL111F0051AB 6

7. Remove the three main clutch lever adjustment screws **(1)**.

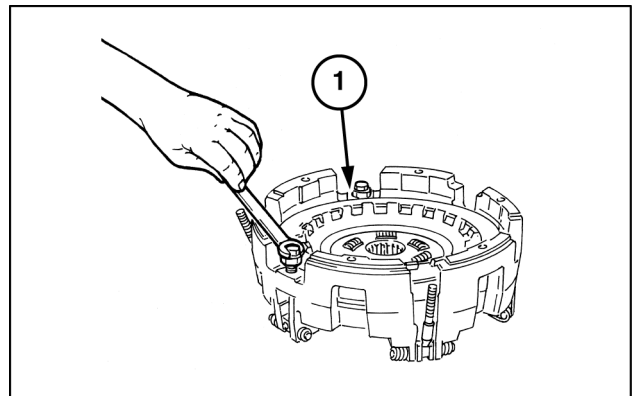

MOL111F0052AB 7

8. Extract the main clutch pressure plate **(1)**.

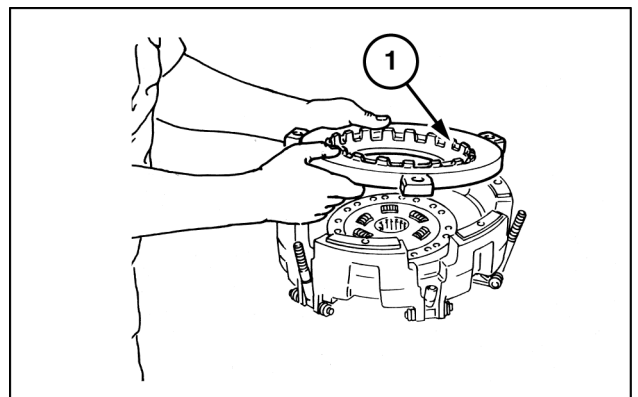

MOL111F0053AB 8

This as a preview PDF file from best-manuals.com



Download full PDF manual at best-manuals.com