

Operator's Manual

ZAXIS

27U-3	27U-3F
30U-3	30U-3F
35U-3	35U-3F
40U-3	40U-3F
50U-3	50U-3F

Hydraulic Excavator

Serial No.

ZX27U-3	020270 and up	ZX27U-3F	050003 and up
ZX30U-3	020639 and up	ZX30U-3F	050059 and up
ZX35U-3	020171 and up	ZX35U-3F	050059 and up
ZX40U-3	020310 and up	ZX40U-3F	050046 and up
ZX50U-3	020215 and up	ZX50U-3F	050345 and up

ZX27U-3, 3F • 30U-3, 3F • 35U-3, 3F • 40U-3, 3F • 50U-3, 3F HYDRAULIC EXCAVATOR OPERATOR'S MANUAL

EM1NE-1-2

 **Hitachi Construction Machinery Co., Ltd.**
URL: <http://www.hitachi-c-m.com>

PRINTED IN JAPAN (E) 2010, 07



Recycle This book is printed on recycled paper.

INTRODUCTION

Read this manual carefully to learn how to operate and service your machine correctly. Failure to do so could result in personal injury or equipment damage.

This standard specification machine can be operated under the following conditions without being modified.
Atmospheric Temperature: -20 °C to 40 °C (-4 °F to 104 °F)
Altitude: 0 m to 1500 m (0 ft to 4900 ft)

In case the machine is used under conditions other than described above, consult your authorized dealer.

This manual should be considered a permanent part of your machine and should remain with the machine when you sell it.

This machine is of metric design. Measurements in this manual are metric. Use only metric hardware and tools as specified.

- SI Units (International System of Units) are used in this manual.

For reference MKS system units and English units are also indicated in parentheses after the SI units.

Example : 24.5 MPa (250 kgf/cm², 3560 psi)

Right-hand and left-hand sides are determined by facing in the direction of forward travel.

Write product identification numbers in the Machine Numbers section. Accurately record all the numbers to help in tracing the machine should it be stolen. Your dealer also needs these numbers when you order parts. If this manual is kept on the machine, also file the identification numbers in a secure place off the machine.

Use only diesel fuel with quality specified in JIS K-2204, EN-590, ASTM D-975, GOST R52368 or GB252. Failure to use diesel fuel with quality as specified above may allow the engine to emit exhaust gas which cleanliness can not conform to the requests in various relevant regulations. In addition, serious damage to the engine may result. Consult with your authorized dealer for detailed information.

Hitachi machine models are classified into 1 model and 1 type as shown in the table below. When referring to the texts and/or illustrations indicated with the applicable machine model names in this manual, check that the machine models concerned are included using this table.

In this manual, F Type is also included in the model not noted.

Model	
Std. Model	ZX27U-3, 30U-3, 35U-3, 40U-3, 50U-3
Type	
F Type	ZX27U-3F, 30U-3F, 35U-3F, 40U-3F, 50U-3F

Warranty is provided as a part of Hitachi's support program for customers who operate and maintain their equipment as described in this manual. The warranty is explained on the warranty certificate which you should have received from your dealer.

This warranty provides you the assurance that Hitachi will back its products where defects appear within the warranty period. In some circumstances, Hitachi also provides field improvements, often without charge to the customer, even if the product is out of warranty. **Should the equipment be abused, or modified to change its performance beyond the original factory specifications, the warranty will become void and field improvements may be denied.** Setting fuel delivery above specifications or otherwise overpowering machines will result in such action.

Only qualified, experienced operators officially licensed (according to local law) should be allowed to operate the machine. Moreover, only officially licensed personnel should be allowed to inspect and service the machine.

PRIOR TO OPERATING THIS MACHINE, INCLUDING SATELLITE COMMUNICATION SYSTEM, IN A COUNTRY OTHER THAN A COUNTRY OF ITS INTENDED USE, IT MAY BE NECESSARY TO MAKE MODIFICATIONS TO IT SO THAT IT COMPLIES WITH THE LOCAL REGULATORY STANDARDS (INCLUDING SAFETY STANDARDS) AND LEGAL REQUIREMENTS OF THAT PARTICULAR COUNTRY. PLEASE DO NOT EXPORT OR OPERATE THIS MACHINE OUTSIDE OF THE COUNTRY OF ITS INTENDED USE UNTIL SUCH COMPLIANCE HAS BEEN CONFIRMED. PLEASE CONTACT HITACHI CONSTRUCTION MACHINERY CO., LTD. OR ANY OF OUR AUTHORIZED DISTRIBUTOR OR DEALER IF YOU HAVE ANY QUESTIONS CONCERNING COMPLIANCE.

All information, illustrations and specifications in this manual are based on the latest product information available at the time of publication. The right is reserved to make changes at any time without notice.

CALIFORNIA Proposition 65 Warning

Diesel engine exhaust and some of its constituents are known to the State of California to cause cancer, birth defects, and other reproductive harm.

INDEX

MACHINE NUMBERS

SAFETY

SAFETY SIGNS

COMPONENTS NAME

OPERATOR'S STATION

BREAK-IN

OPERATING ENGINE

DRIVING MACHINE

OPERATING MACHINE

TRANSPORTING

MAINTENANCE

CONSUMABLE PARTS LIST

MAINTENANCE UNDER SPECIAL ENVIRONMENTAL CONDITIONS

STORAGE

TROUBLESHOOTING

SPECIFICATIONS

OPTIONAL ATTACHMENT AND DEVICE

INDEX

CONTENTS

MACHINE NUMBERS	1	Beware of Asbestos and Silicon Dust and Other Contamination	S-28
SAFETY	S-1	Precautions for Welding and Grinding	S-29
Recognize Safety Information	S-1	Avoid Heating Near Pressurized Fluid Lines	S-29
Understand Signal Words	S-1	Avoid Applying Heat to Lines Containing Flammable Fluids	S-29
Follow Safety Instructions	S-2	Remove Paint Before Welding or Heating	S-30
Prepare For Emergencies	S-2	Prevent Battery Explosions	S-30
Wear Protective Clothing	S-3	Precautions for Handling Refrigerant	S-31
Protect Against Noise	S-3	Handle Chemical Products Safely	S-31
Inspect Machine	S-3	Dispose of Waste Properly	S-32
Tidy Up Inside Operator's Space	S-4	SAFETY SIGNS	S-33
Use Handrails and Steps	S-4	COMPONENTS NAME	1-1
Never Ride Attachment	S-4	OPERATOR'S STATION	1-2
Adjust the Operator's Seat	S-5	Pedals, Levers and Monitor Panel	1-2
Ensure Safety Before Rising From or Leaving Operator's Seat	S-5	Key Switch	1-4
Fasten Your Seat Belt	S-5	Switch Panel	1-4
Move and Operate Machine Safely	S-6	Monitor Panel	1-5
Operate Only From Operator's Seat	S-7	Hour Meter	1-5
Jump Starting	S-7	Fuel Gauge	1-5
Keep Riders Off Machine	S-7	Coolant Temperature Gauge	1-5
Precautions for Operations	S-8	System Failure Indicator	1-6
Investigate Job Site Beforehand	S-9	Engine Oil Pressure Indicator	1-6
Equipment of OPG	S-10	Overheat Indicator	1-6
Provide Signals for Jobs Involving Multiple Machines	S-10	Fuel Level Indicator	1-6
Confirm Direction of Machine to be Driven	S-10	Alternator Indicator	1-7
Drive Machine Safely	S-11	Preheat Indicator	1-7
Avoid Injury From Rollaway Accidents	S-13	Fast Travel Mode Indicator	1-7
Avoid Injury From Back-over and Swing Accidents	S-14	Auto-Idle Indicator (Except ZX27U-3)	1-7
Keep Person Clear From Working Area	S-15	Auto-Idle Switch (Except ZX27U-3)	1-8
Never Position Bucket Over Anyone	S-15	Air Conditioner Operation	1-9
Avoid Undercutting	S-15	Tips for Air Conditioner Usage	1-11
Avoid Tipping	S-16	Radio (Cab Equipped Machines)	1-12
Never Undercut a High Bank	S-16	AM/FM Radio Operation	1-13
Dig With Caution	S-17	Cab Door Release Lever (Cab-equipped Machines)	1-16
Operate With Caution	S-17	Opening/Closing Cab Front Window (Cab-equipped Machines)	1-17
Avoid Power Lines	S-17	Adjusting Operator's Seat	1-18
Precautions for Lightning	S-18	Tool and Operator's Manual Boxes	1-18
Do Not Use for Craning Operations	S-18	Emergency Exit (Cab-equipped Machines)	1-19
Protect Against Flying Debris	S-18	Seat Belt (Optional)	1-20
Park Machine Safely	S-19	Cab Light (Cab-equipped Machines)	1-20
Handle Fluids Safely --- Avoid Fires	S-19	BREAK-IN	2-1
Safety Transporting	S-20	Breaking in New Machine	2-1
Practice Safe Maintenance	S-21	OPERATING ENGINE	3-1
Warn Others of Service Work	S-22	Before Starting Engine	3-1
Support Machine Properly	S-23	Starting Engine	3-2
Stay Clear of Moving Parts	S-23	Check Machine After Starting Engine	3-4
Prevent Parts From Flying	S-23	Using Booster Battery	3-5
Store Attachments Safely	S-24		
Prevent Burns	S-24		
Replace Rubber Hoses Periodically	S-25		
Avoid High-Pressure Fluids	S-25		
Prevent Fires	S-26		
Evacuating in Case of Fire	S-27		
Beware of Exhaust Fumes	S-28		

CONTENTS

Stopping Engine	3-6	Securing Machine to Trailer for Transportation (Machines with Lightweight Object-Towing Bracket Provided)	6-3
DRIVING MACHINE	4-1	Securing Machine to Trailer for Transportation (Machines without Lightweight Object-Towing Bracket Provided)	6-4
Travel Levers and Pedals	4-1	Unloading	6-5
Travel Mode Switch	4-3	Lifting Machine With Crane	6-6
Traveling on Soft Ground	4-4	MAINTENANCE	7-1
Raise One Track Using Boom and Arm	4-4	Procedures	7-1
Towing Machine	4-5	Check Hour Meter Regularly	7-2
Driving in Water or on Soft Ground	4-6	Use Correct Fuels and Lubricants	7-2
Parking and Stopping on Slopes	4-7	Prepare Machine for Inspection/Maintenance	7-3
Parking on Slopes	4-7	Opening/Closing Engine Access Covers	7-4
OPERATING MACHINE	5-1	Opening/Closing Tank Covers	7-5
Control Lever (ISO Excavator Pattern)	5-1	Daily Inspection	7-6
Control Lever (H-pattern: HITACHI Excavator Pattern)	5-2	Periodic Replacement of Parts	7-7
Control Lever (SAE-backhoe Pattern)	5-3	Maintenance Guide	7-8
Boom-Swing Pedal	5-4	Brand Names of Recommended Oil and Lubricants	7-11
Auxiliary Pedal	5-5	A. Greasing	7-13
AUX Function Lever Switch (Optional)	5-5	Front Joint Pins (Incl. Swing Post Joint Pins)	7-13
Blade Lever	5-6	Bucket and Link Pins	7-16
Precautions for Blade Operation	5-7	Blade Pins	7-16
Pilot Control Shut-off Lever	5-8	Swing Bearing	7-17
Warming Up Operation	5-9	Swing Internal Gear	7-18
Warming Up in Cold Weather	5-9	Control Lever Universal Joint	7-18
Auto-Idle Control (Except ZX27U-3)	5-10	Tilt Mechanism	7-19
Operating Backhoe	5-11	B. Engine	7-20
Grading Operation	5-12	Engine Oil	7-20
Avoid Driving Bucket Teeth into Ground	5-12	Change Engine Oil	7-20
Avoid Abusive Operation	5-12	Replace Engine Oil Filter	7-20
Avoid Striking With Bucket	5-13	C. Transmission	7-22
Avoid Excavation Using Upperstructure and/or Boom Swing Power	5-13	Travel Reduction Gear	7-22
Use Correct Track Shoe	5-13	D. Hydraulic System	7-24
Avoid other than Specified Machine Operations	5-14	Inspection and Maintenance of Hydraulic Equipment	7-24
Boom Cylinder may Hit Blade	5-15	Check Hydraulic Oil Level	7-25
Shackle Bracket Usage	5-16	Drain Hydraulic Oil Tank Sump	7-26
Avoid Hitting Blade With Bucket	5-17	Change Hydraulic Oil	7-27
Avoid Colliding Blade Against Rocks	5-17	Clean Suction Filter	7-30
Avoid Colliding Boom Cylinder With Track	5-17	Replace Full Flow Filter Element	7-31
Precautions for Installing Wide Bucket or Special Type Bucket	5-17	Replace Pilot Filter Element	7-32
Using Rubber Crawler	5-18	Check Hoses and Lines	7-34
Piping for Breaker and Crusher	5-20	E. Fuel System	7-41
Hydraulic Breaker (Optional)	5-21	Check Water Separator	7-42
Crusher Operation (Optional)	5-25	Drain Fuel Tank Sump	7-42
Precautions for After Operating Machine	5-26	Replace Fuel Filter	7-43
Auxiliary Flow Rate Control (Optional) (Except ZX27U-3)	5-27	Check Fuel Hoses	7-44
Emergency Boom Lowering Procedure	5-28	F. Air Cleaner	7-45
TRANSPORTING	6-1	Clean Air Cleaner Element	7-45
Transporting by Road	6-1	Replace Air Cleaner Element	7-45
Trailer Loading/Unloading	6-1	G. Cooling System	7-46
Loading	6-2	Check Coolant Level	7-47
		Check and Adjust Fan Belt Tension	7-48

CONTENTS

Change Coolant	7-49	Specifications ZX40U-3	12-13
Clean Radiator and Oil Cooler Core	7-50	Working Ranges ZX40U-3	12-14
Clean Air Conditioner Condenser.....	7-50	Shoe Types and Applications ZX40U-3.....	12-15
H. Electrical System.....	7-51	Bucket Types and Applications ZX40U-3.....	12-16
Battery	7-51	Specifications ZX50U-3	12-17
Replacing Fuses.....	7-54	Working Ranges ZX50U-3	12-18
I. Miscellaneous.....	7-55	Shoe Types and Applications ZX50U-3.....	12-19
Check Bucket Teeth for Looseness and/or Wear	7-55	Bucket Types and Applications ZX50U-3.....	12-20
Replace Bucket	7-57		
Adjust Track Sag (Rubber Crawler) and Check for Damage	7-58	OPTIONAL ATTACHMENT AND DEVICE	13-1
Replace Rubber Crawler	7-60	Ignition Block System (Optional)	13-1
Check Track Sag (Steel Crawler) (Optional)	7-62	Additional Counterweight (Optional).....	13-8
Check and Replace Seat Belt	7-65		
Check Air Conditioner (Machine with Cab)	7-66	INDEX.....	14-1
Clean and Replace Air Conditioner Recirculation Filter.....	7-68		
Clean Cab Floor	7-70		
Check, Clean and Function Check Injection Nozzle	7-71		
Check and Adjust Valve Clearance	7-71		
Check and Adjust Injection Timing	7-71		
Measure Engine Compression Pressure	7-71		
Check Starter and Alternator.....	7-71		
Check Crankcase Breather	7-71		
Check Radiator Cap	7-71		
Check Tightening Torque of Bolts and Nuts	7-72		
Check Tilt Mechanism Fulcrum Bolts for Looseness.....	7-75		
Preparation for Inspection and Maintenance	7-76		
Tilting Floor Down	7-78		
CONSUMABLE PARTS LIST	8-1		
MAINTENANCE UNDER SPECIAL ENVIRONMENTAL CONDITIONS	9-1		
STORAGE	10-1		
Storing Machine.....	10-1		
Removing Machine from Storage	10-2		
TROUBLESHOOTING	11-1		
SPECIFICATIONS	12-1		
Specifications ZX27U-3	12-1		
Working Ranges ZX27U-3	12-2		
Shoe Types and Applications ZX27U-3.....	12-3		
Bucket Types and Applications ZX27U-3	12-4		
Specifications ZX30U-3	12-5		
Working Ranges ZX30U-3	12-6		
Shoe Types and Applications ZX30U-3.....	12-7		
Bucket Types and Applications ZX30U-3	12-8		
Specifications ZX35U-3	12-9		
Working Ranges ZX35U-3	12-10		
Shoe Types and Applications ZX35U-3.....	12-11		
Bucket Types and Applications ZX35U-3	12-12		

CONTENTS

MEMO

A series of horizontal dotted lines for writing a memo.

MACHINE NUMBERS

The manufacturing Nos. explained in this group is the individual number (serial No.) given to each machine and hydraulic components. These numbers are requested when inquiring any information on the machine and/or components. Fill these serial Nos. in the blank spaces in this group to immediately make them available upon request.

Machine

MODEL/TYPE: _____

PRODUCT IDENTIFICATION NUMBER:

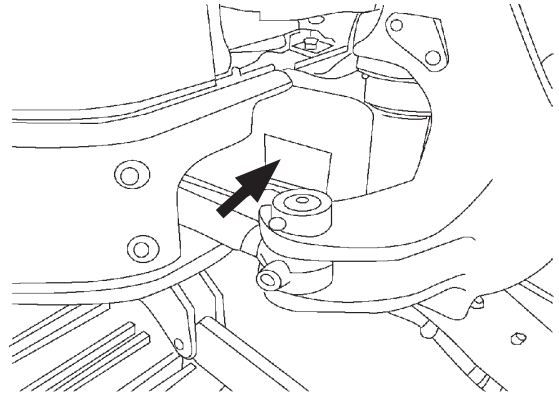

M1M7-00-001

Product Identification Number

PRODUCT IDENTIFICATION NUMBER:



NOTE:
Marks to indicate the start and end of the PIN
HCM1NE00X00020001
PRODUCT IDENTIFICATION NUMBER (PIN)

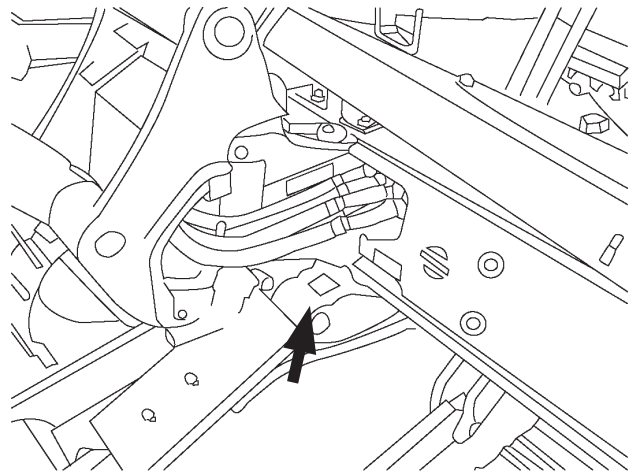

M1M7-00-002

Engine

TYPE: _____

MFG. NO.: _____

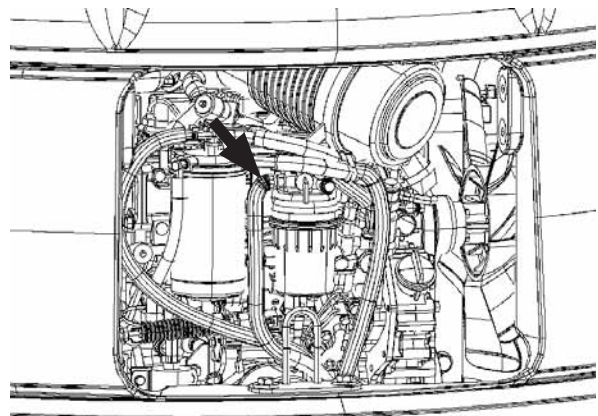

M1NE-00-001

MACHINE NUMBERS

Travel Motor

TYPE: _____

MFG. NO.: _____

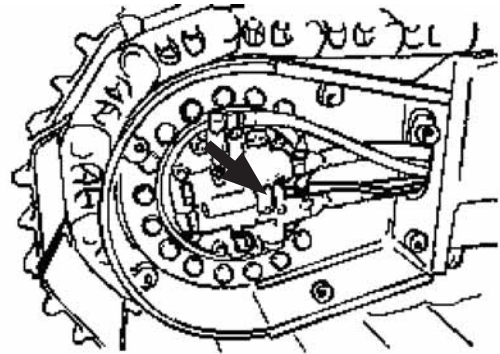

M1M0-00-004

Swing Motor

TYPE: _____

MFG. NO.: _____

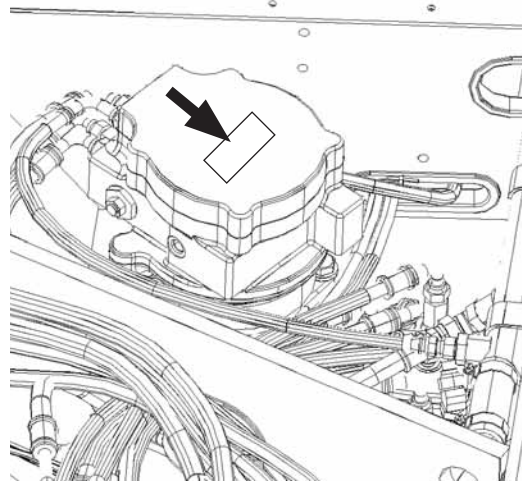

M1NE-00-002

Hydraulic Pump

TYPE: _____

MFG. NO.: _____

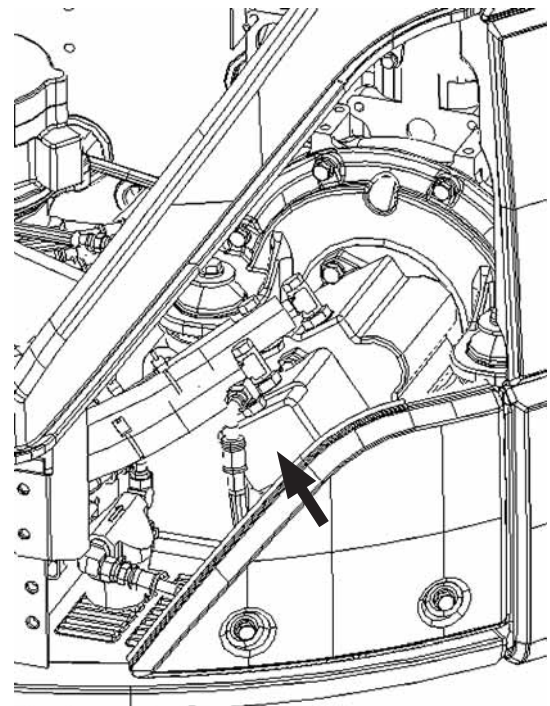

M1NE-00-003

SAFETY

Recognize Safety Information

- These are the **SAFETY ALERT SYMBOLS**.
 - When you see these symbols on your machine or in this manual, be alert to the potential for personal injury.
 - Follow recommended precautions and safe operating practices.



SA-688

Understand Signal Words

- On machine safety signs, signal words designating the degree or level of hazard - **DANGER**, **WARNING**, or **CAUTION** - are used with the safety alert symbol.
 - **DANGER** indicates an imminently hazardous situation which, if not avoided, will result in death or serious injury.
 - **WARNING** indicates a potentially hazardous situation which, if not avoided, could result in death or serious injury.
 - **CAUTION** indicates a potentially hazardous situation which, if not avoided, may result in minor or moderate injury.
 - **DANGER** or **WARNING** safety signs are located near specific hazards. General precautions are listed on **CAUTION** safety signs.
 - Some safety signs do not use any of the designated signal words above after the safety alert symbol are occasionally used on this machine.
- To avoid confusing machine protection with personal safety messages, a signal word **IMPORTANT** indicates a situation which, if not avoided, could result in damage to the machine.
- **f NOTE** indicates an additional explanation for an element of information.



IMPORTANT



SA-1223

SAFETY

Follow Safety Instructions

- Carefully read and follow all safety signs on the machine as well as all safety messages in this manual.
- Safety signs must be installed, maintained and replaced if damaged.
 - If a safety sign or this manual is damaged or missing, order a replacement from your authorized dealer in the same way you order other replacement parts (be sure to state machine model and serial number when ordering).
- Allow only properly trained, qualified, authorized personnel to operate the machine.
- Learn how to correctly operate and service the machine.
- Keep your machine in proper working condition.
- Always operate the machine within the specification.
 - Unauthorized modifications of the machine may impair the functions and/or safety and affect machine life and the warranty will become void.
- The safety messages in this SAFETY chapter are intended to illustrate basic safety procedures of machines. However it is impossible for these safety messages to cover every possible hazardous situation you may encounter. If you have any questions concerning safety, you should first consult your supervisor and/or your authorized dealer before operating or performing maintenance work on the machine.



SA-003

Prepare For Emergencies

- Be prepared if a fire starts or if an accident occurs.
 - Keep a first aid kit and fire extinguisher on hand.
 - Thoroughly read and understand the label attached on the fire extinguisher and use it properly.
 - To ensure that a fire extinguisher can be always used when necessary, check and service the fire extinguisher at the recommended intervals as specified in the fire-extinguisher manual.
 - Establish emergency procedure guidelines to cope with any fire or accidents which may occur.
- Keep emergency numbers for doctors, ambulance service, hospitals, and fire department posted near your telephone.



SA-437

SAFETY

Wear Protective Clothing

- Wear close fitting clothing and safety equipment appropriate to the job.

You may need:

- A hard hat
- Safety belt
- Safety shoes
- Safety glasses, goggles, or face shield
- Heavy gloves
- Hearing protection
- Reflective clothing
- Wet weather gear
- Respirator or filter mask.

Be sure to wear the correct equipment and clothing for the job. Do not take any chances.

- Avoid wearing loose clothing, jewelry, or other items that can catch on control levers or other parts of the machine.
- Operating equipment safely requires the full attention of the operator. Do not wear radio or music headphones while operating the machine.



SA-438

Protect Against Noise

- Prolonged exposure to loud noise can cause impairment or loss of hearing.
- Wear a suitable hearing protective device such as earmuffs or earplugs to protect against objectionable or uncomfortably loud noises.



SA-434

Inspect Machine

- If any abnormality is found, be sure to repair it immediately before operating the machine.
- In the walk-around inspection, be sure to cover all points described in the "Daily Inspection" section in the operator's manual.



SA-435

SAFETY

Tidy Up Inside Operator's Space

- Always keep inside the cab clean by observing instructions below, to prevent any personal accidents from occurring.
- Remove mud and/or oily material from the shoe soles before entering the operator's space. If pedals are operated without removing mud or oily matter, the foot may slip off the pedal, possibly creating a hazardous situation.
- Do not leave parts and/or tools around the operator's seat.
- Do not keep a transparent water bottle in the cab. The transparent water bottle may focus the sun light like a lens, possibly causing a fire.
- Do not wear radio or music headphones and do not use a cell phone while traveling or operating the machine.
- Never allow hazardous materials such as combustible and/or explosive material in the operator's space.
- Do not leave cigarette lighters in the cab. If the temperature in the cab increases, the lighter may explode.

Use Handrails and Steps

- Falling is one of the major causes of personal injury.
- When you get on and off the machine, always face the machine.
- Maintain a three-point contact with the steps and handrails.
- Do not use any controls as handholds.
- Never jump on or off the machine. Never mount or dismount a moving machine.
- In case adhered slippery material such as oil, grease, or mud is present on steps, handrails, or platforms, thoroughly remove such material.



SA-439

Never Ride Attachment

- Never allow anyone to ride attachments or the load. This is an extremely dangerous practice.

SAFETY

Adjust the Operator's Seat

- A poorly adjusted seat for either the operator or the work at hand may quickly fatigue the operator leading to mis-operation of the machine.
- The seat should be adjusted whenever the operator for the machine changes.
- The operator should be able to fully depress the pedals and to correctly operate the control levers with his back firmly against the seat back.
- If not, readjust the seat forward or backward, and check again.



SA-378

Ensure Safety Before Rising From or Leaving Operator's Seat

- Before rising from the operator's seat to open/close cab front window or to adjust the seat position, be sure to first lower the front attachment to the ground and then move the pilot control shut-off lever to the LOCK position. Failure to do so may allow the machine to unexpectedly move when a body part unintentionally comes in contact with a control lever, possibly resulting in serious personal injury or death.
- Before leaving the machine, be sure to first lower the front attachment to the ground and then move the pilot control shut-off lever to the LOCK position. Turn the key switch OFF to stop the engine.
- Before leaving the machine, close all windows, doors, and access covers and lock them up.

Fasten Your Seat Belt

- If the machine should overturn, the operator may become injured and/or thrown from the cab. Additionally the operator may be crushed by the overturning machine, resulting in serious injury or death.
- Be sure to remain seated with the seat belt securely fastened whenever operating the machine.
- Prior to operating the machine, thoroughly examine webbing, buckle and attaching hardware. If any item is damaged or worn, replace the seat belt or component before operating the machine. Replace the seat belt at least once every 3 years regardless of appearance.



SA-237

SAFETY

Move and Operate Machine Safely

- Always be aware that there is a potential danger around the machine while operating the machine.
- Take extra care not to run over bystanders. Confirm the location of bystanders before moving, swinging, or operating the machine.
- Always keep the travel alarm and horn in working condition (if equipped).
- Before starting to move or operate the machine, sound the travel alarm and horn to alert bystanders.
- Use a signal person when moving, swinging, or operating the machine in congested areas. Locate the signal person so that the operator can always witness the signal person.
- Coordinate the meanings of all safety signs, hand signals and marks before starting the machine. Appoint a person who is responsible to make a signal and/or guidance.
- Never allow any persons or obstacles to enter the machine operation areas.
- Use appropriate illumination.

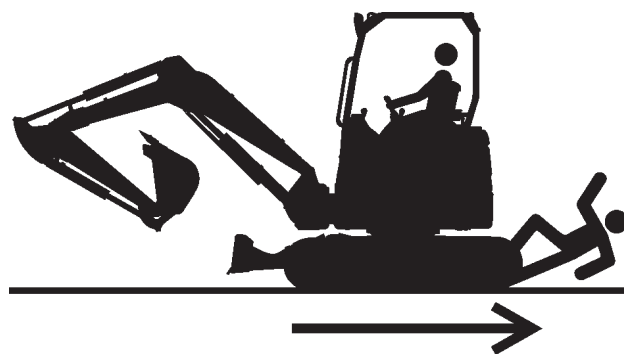

SA-1291

SAFETY

Operate Only From Operator's Seat

- Inappropriate engine starting procedures may cause the machine to runaway, possibly resulting in serious injury or death.
 - Start the engine only when seated in the operator's seat.
 - NEVER start the engine while standing on the tracks or on ground.
 - Do not start engine by shorting across starter terminals. A hazardous situation may be created and/or possible damage to the machine may result.
 - Before starting the engine, confirm that all control levers are in neutral.



SA-444

Jump Starting

- Failure to follow correct jump starting procedures could result in a battery explosion or a runaway machine.
 - If the engine must be jump started, be sure to follow the instructions shown in the "OPERATING ENGINE" chapter.
 - The operator must be seated in the operator's seat so that the machine will be under control when the engine starts. Jump starting is a two-person operation.
 - Never use a frozen battery.
 - Failure to follow correct jump starting procedures could result in a battery explosion or a runaway machine.



SA-032

Keep Riders Off Machine

- Riders on machine are subject to injury such as being struck by foreign objects and being thrown off the machine.
 - Riders also obstruct the operator's view, resulting in the machine being operated in an unsafe manner.
 - Only the operator is allowed on the machine. Keep riders off.



SA-1292

SAFETY

Precautions for Operations

- Thoroughly make certain safety at the work site before starting operations. Especially always observe the following points.
 - Be sure to wear close fitting clothing and required safety items, such as a hard hat, when operating the machine.
 - Keep all bystanders and unnecessary objects out of and away from the machine working areas. Always beware of the surroundings while operating the machine. Take care not to allow the rear part of the upperstructure to come in contact with objects when swinging the machine in a small area.
 - When loading a dump truck, bring the bucket from the rear side of the dump truck to avoid moving the bucket over the dump truck cab or over any co-workers.

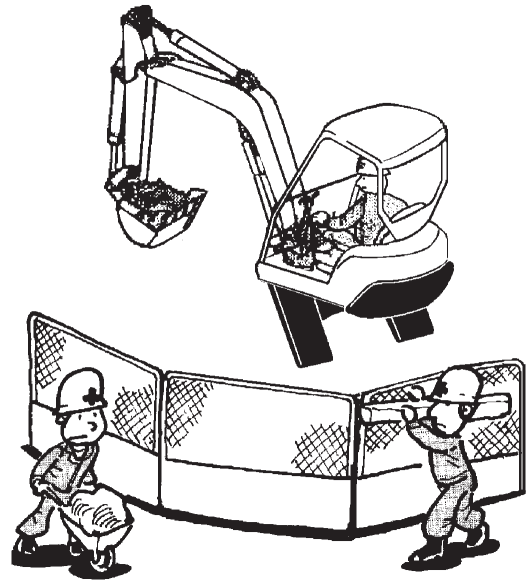

M586-12-012

SAFETY

Investigate Job Site Beforehand

- When working at the edge of an excavation or on a road shoulder, the machine could tip over due to collapse of the ground, possibly resulting in serious injury or death.
 - Investigate the configuration and ground conditions of the job site beforehand to prevent the machine from falling and to prevent the ground, stockpiles, or banks from collapsing.
 - Make a work plan. Use machines appropriate to the work and job site.
 - Reinforce ground, edges, and road shoulders as necessary. Keep the machine well back from the edges of excavations and road shoulders.
 - When working on an incline or on a road shoulder, employ a signal person as required.
 - Never allow bystanders to enter the working area such as swing radius or traveling range.
 - When the footing is weak, reinforce the ground before starting work.
 - When working on frozen ground, be extremely alert. As ambient temperatures rise, footing may become loose and slippery.
 - When operating the machine near open flame, sparks, and/or dead grass, a fire may easily break out. Use special care not to cause a fire.
- Make sure the work site ground has sufficient strength to firmly support the machine. When working close to an excavation or on road shoulders, operate the machine with the tracks positioned perpendicular to the cliff face with travel motors at the rear and with the blade at the front, so that the machine can more easily evacuate if the cliff face collapses.
- If working at the bottom of a cliff or on a high bank is required, be sure to investigate the area first and confirm that no danger of the cliff or bank collapsing exists. If any possibility of cliff or bank collapsing exists, do not work in that area.
- Soft ground may collapse when operating the machine on it, possibly causing the machine to tip over. When working on a soft ground is required, be sure to reinforce the ground first using large pieces of steel plates strong enough and firm to easily support the machine.
- Note that there is always a possibility of machine tipping over when working on rough terrain or on slopes. Prevent machine tipping over from occurring. Operate the machine slowly to ensure safe operation.



SA-1293

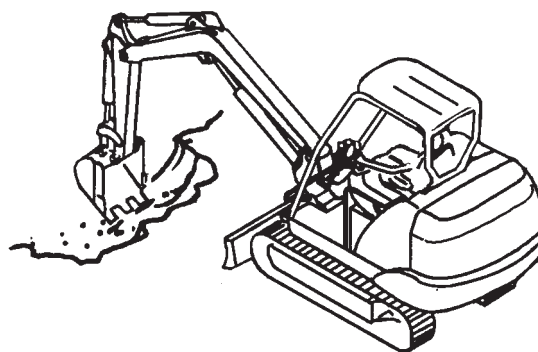

M586-05-021

SAFETY

Equipment of OPG

- In case the machine is operated in areas where the possibility of falling stones or debris exists, equip genuine Hitachi OPG guard. Contact your nearest Hitachi dealer for installation method of the OPG guard. Depending on the specifications applied to your machine, modification of the machine to meet ROPS standards will be possible.
- To maintain unimpaired operator protection and manufacture's protective structure.
 - Damaged ROPS, OPG guard must be replaced, not repaired or revised.
 - Any alternation to the ROPS or OPG guard must be approved by the manufacturer.

ROPS : Roll Over Protective Structure

OPG : Operator Protective Guard

Provide Signals for Jobs Involving Multiple Machines

- In case more than one machine is operated in the same job site, accidental collision between machines may cause serious injury or death.
- For jobs involving multiple machines, provide signals commonly known by all personnel involved. Also, appoint a signal person to coordinate the job site. Make sure that all personnel obey the signal person's directions.



SA-481

Confirm Direction of Machine to be Driven

- Incorrect travel pedal/lever operation may result in serious injury or death.
 - Before driving the machine, confirm the position of the undercarriage in relation to the operator's position.
 - If the travel motors are located towards the front of the cab, the machine will move in the reverse direction when travel pedals/levers are operated.

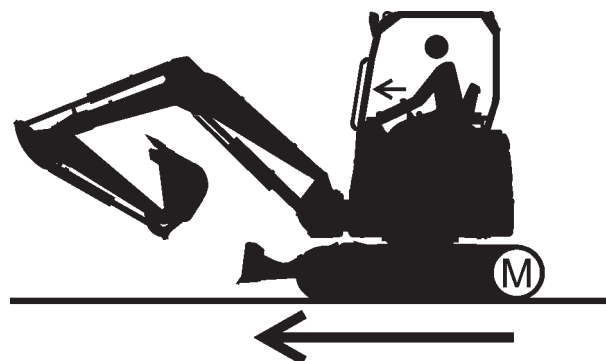

SA-1294

SAFETY

Drive Machine Safely

- Use a signal person when traveling the machine along road shoulders or in congested areas.
- Driving the machine in the incorrect direction may result in serious injury or death and/or severe damage to property.
- Before driving the machine, always confirm that the travel pedals/levers direction corresponds to the direction you wish to drive.
 - Be sure to detour around any obstructions.
 - Avoid traveling over obstructions. Soil, fragments of rocks, and/or metal pieces may scatter around the machine. Do not allow personnel to stay around the machine while traveling.
- Driving on a slope may cause the machine to slip or overturn, possibly resulting in serious injury or death.
 - Never attempt to ascend or descend 30 degrees or steeper slopes.
 - Be sure to fasten the seat belt.
 - When driving up or down a slope, keep the bucket facing the direction of travel, approximately 200 to 300 mm (8 to 12 in) (A) above the ground.
 - If machine starts to skid or becomes unstable, immediately lower the bucket to the ground and stop.
 - Driving across the face of a slope or steering on a slope may cause the machine to skid or turnover. If the direction must be changed, move the machine to level ground, then, change the direction to ensure safe operation.
 - Avoid swinging the upperstructure on slopes. Never attempt to swing the upperstructure downhill. The machine may tip over. If swinging uphill is unavoidable, carefully operate the upperstructure and boom at slow speed.
 - If the engine stalls on a slope, immediately lower the bucket to the ground. Return the control levers to neutral. Then, restart the engine.
 - Be sure to thoroughly warm up the machine before ascending steep slopes. If hydraulic oil has not warmed up sufficiently, sufficient performance may not be obtained.

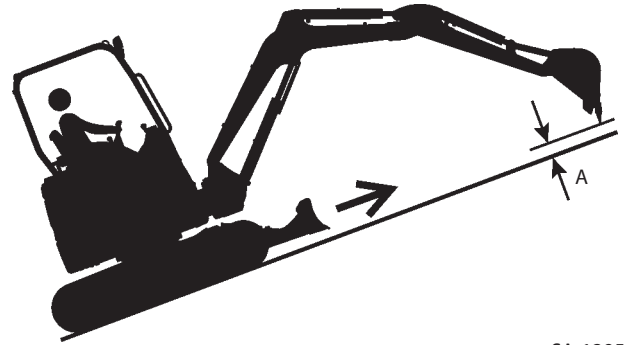

SA-1295

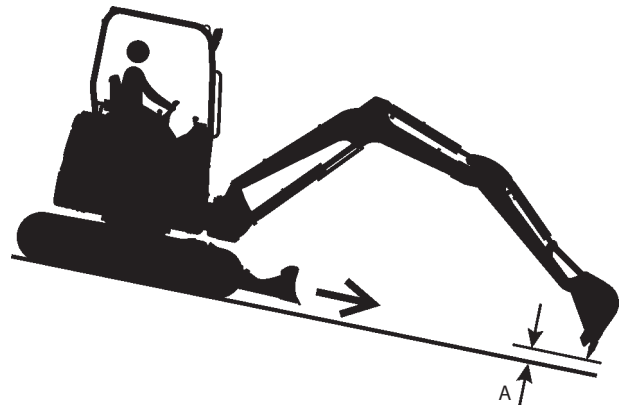

SA-1296

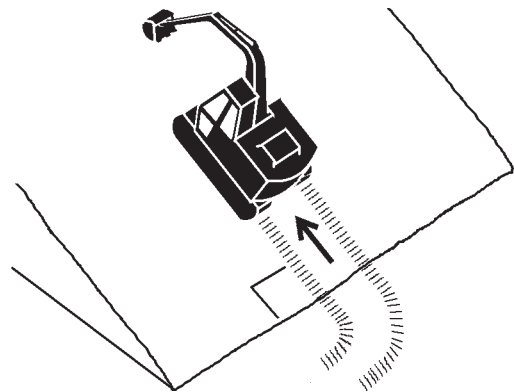

SA-441

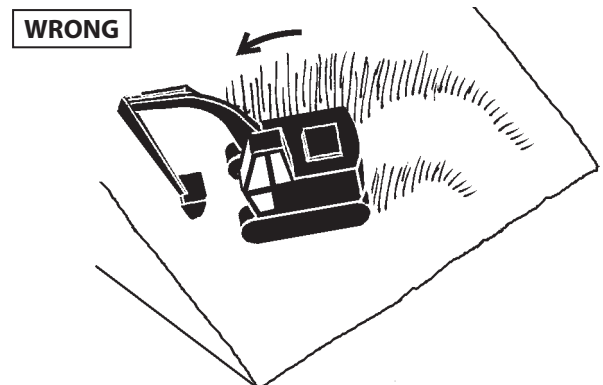

SA-589

SAFETY

- Traveling down a slope in the fast mode requires a longer time to stop the machine. When traveling down a slope, place travel mode switch (1) in the TURTLE  position.
- Select a travel route that is as flat as possible. Steer the machine as straight as possible, making small gradual changes repeatedly in direction.
- Check the strengths of bridges and road shoulders before traveling on them, and reinforce if necessary.
- When the machine is equipped with steel shoes, cover the road surface with wood plates in order not to damage the road surface. Be careful of steering when operating on asphalt roads in summer.
- When crossing train tracks, lay wood plates over the tracks not to allow the machine to ride on only the rails.
- Check that the machine can pass under a bridge and electric lines before driving the machine.
- When crossing a river, drive the machine slowly while measuring the depth of the river using the bucket. Do not cross the river when the depth of the river is deeper than the upper track shoe surface.
- Reduce the engine speed when traveling on rough terrains. Select a slow travel speed. Slower speed will reduce possible damage to the machine.
- Drive the machine so that the travel motors do not come in contact with loose rocks. If the machine crosses over an obstruction, abnormally large loads may be loaded on the machine. Avoid contact with an obstruction while traveling the machine.
- During freezing weather, always clean snow and ice from track shoes before driving the machine on snowy and/or frozen roads, or loading and unloading the machine for transportation, to prevent the machine from slipping.

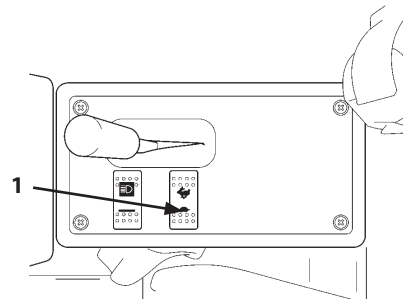

ZX27U-3 (Canopy)

M1M7-01-033

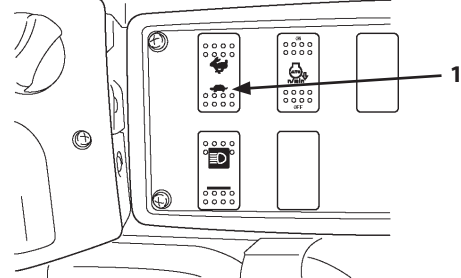

ZX30U-3, 35U-3, 40U-3, 50U-3
(Canopy)

M1NE-01-010

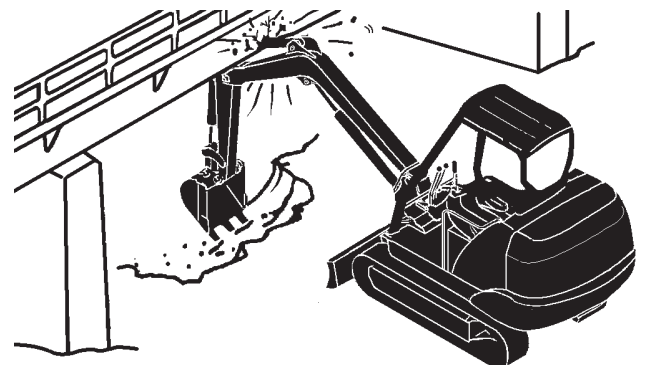
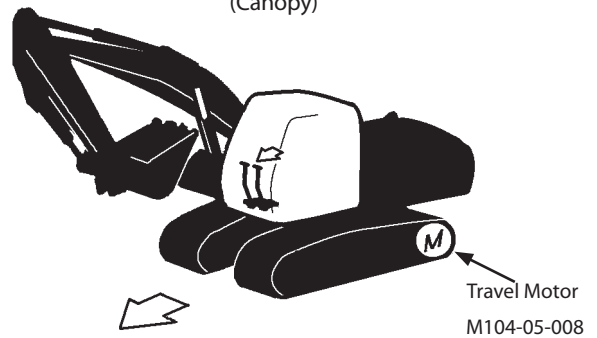

SA-673

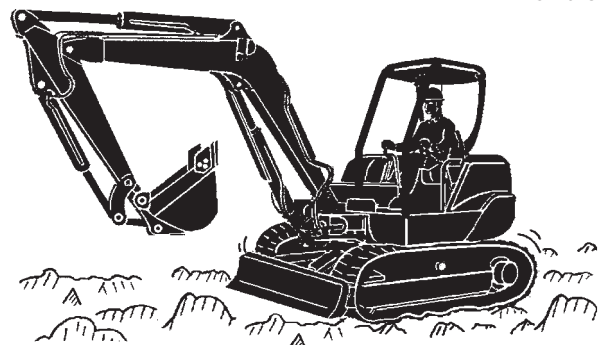

M586-05-002

SAFETY

Avoid Injury From Rollaway Accidents

- Death or serious injury may result if you attempt to mount or try to bodily stop a moving machine.
- Park the machine in compliance with the safe parking procedures described on page S-19 to prevent the machine from running away.
- Block both tracks and lower the bucket to the ground, thrust the bucket teeth into the ground if you must park on a grade.
- Park at a reasonable distance from other machines.

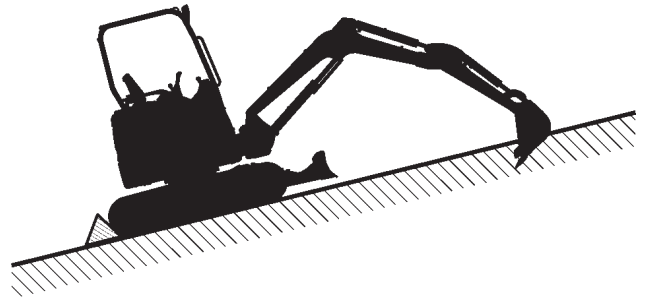

SA-1297

SAFETY

Avoid Injury From Back-over and Swing Accidents

- If any person is present near the machine when backing or swinging the upperstructure, the machine may hit or run over that person, resulting in serious injury or death.

To avoid back-over and swing accidents:

- Always look around **BEFORE YOU BACK UP AND SWING THE MACHINE**. BE SURE THAT ALL BYSTANDERS ARE CLEAR.
- Keep the travel alarm in working condition (if equipped). **ALWAYS BE ALERT FOR BYSTANDERS MOVING INTO THE WORK AREA**. USE THE HORN OR OTHER SIGNAL TO WARN BYSTANDERS BEFORE MOVING MACHINE.
- **USE A SIGNAL PERSON WHEN BACKING UP IF YOUR VIEW IS OBSTRUCTED**. ALWAYS KEEP THE SIGNAL PERSON IN VIEW.
Use hand signals, which conform to your local regulations, when work conditions require a signal person.
- No machine motions shall be made unless signals are clearly understood by both signal person and operator.
- Learn the meanings of all flags, signs, and markings used on the job and confirm who has the responsibility for signaling.
- Keep windows, mirrors, and lights clean and in good condition.
- Dust, heavy rain, fog, etc., can reduce visibility. As visibility decreases, reduce speed and use proper lighting.
- Read and understand all operating instructions in the operator's manual.



SA-383

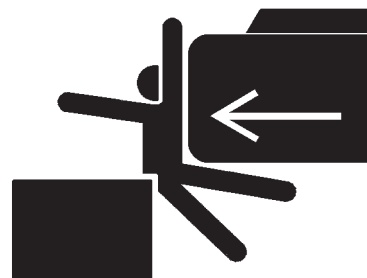

SA-384

021-E01A-0494-8

SAFETY

Keep Person Clear From Working Area

- If a person is present near the operating machine, the person may come in contact with the swinging front attachment or counterweight and/or may be crushed against an other object, resulting in serious injury or death.
- Before operating the machine, set up barriers to the sides and rear area of the bucket swing radius to prevent anyone from entering the work area.
- Make sure that no personnel other than the signal person or no obstacles are present in the working area before operating the machine.

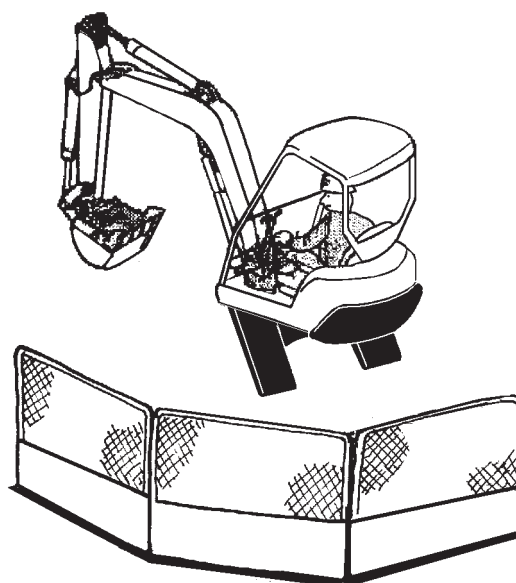

SA-667

Never Position Bucket Over Anyone

- Never lift, move, or swing bucket above anyone or a truck cab. Serious injury or machine damage may result due to bucket load spill or due to collision with the bucket.
- Never allow the bucket to pass over anyone to avoid personal injury or death.



SA-668

Avoid Undercutting

- In order to retreat from the edge of an excavation if the footing should collapse, always position the undercarriage perpendicular to the edge of the excavation with the travel motors at the rear.
- If the footing starts to collapse and if retreat is not possible, do not raise the front attachment in a panic. Lowering the front attachment may be safer in most cases.

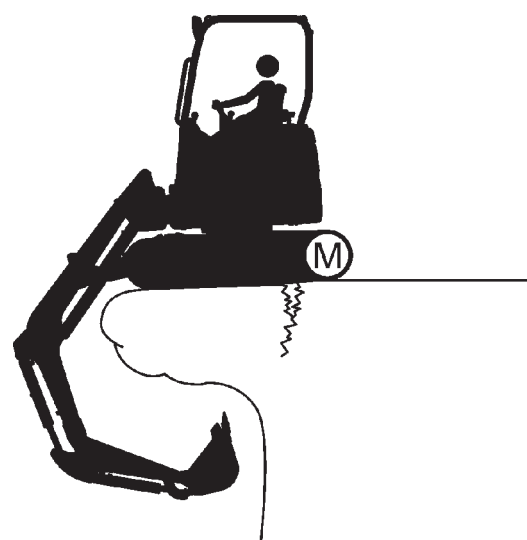

SA-1300

SAFETY

Avoid Tipping

- The danger of tipping is always present when operating on a grade, possibly resulting in serious injury or death.

To avoid tipping:

- Be extra careful before operating on a grade.
 - Prepare machine operating area flat.
 - Keep the bucket low to the ground and close to the machine.
 - Reduce operating speeds to avoid tipping or slipping.
 - Avoid changing direction when traveling on grades.
 - NEVER attempt to travel across a grade steeper than 15 degrees if crossing the grade is unavoidable.
 - Reduce swing speed as necessary when swinging loads.

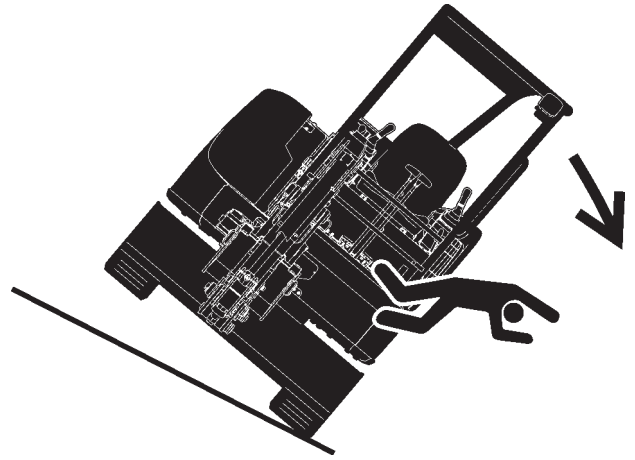

SA-1301

- Be careful when working on frozen ground.
 - Temperature increases will cause the ground to become soft and make ground travel unstable.

025-E01A-0540-4

Never Undercut a High Bank

- The edges could collapse or a land slide could occur causing serious injury or death.

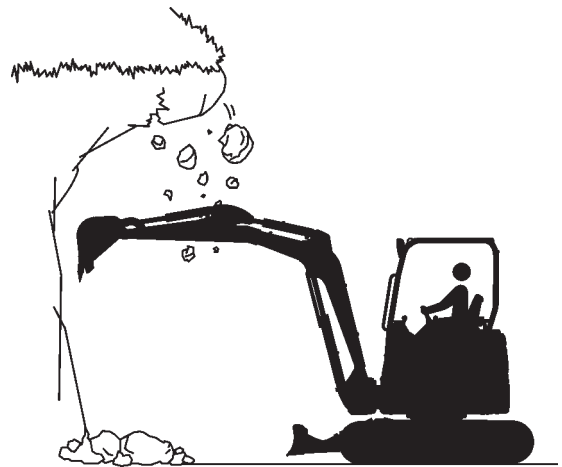

SA-1302

SAFETY

Dig With Caution

- Accidental severing of underground cables or gas lines may cause an explosion and/or fire, possibly resulting in serious injury or death.
- Before digging check the location of cables, gas lines, and water lines.
- Keep the minimum distance required, by law, from cables, gas lines, and water lines.
- If a fiber optic cable should be accidentally severed, do not look into the end. Doing so may result in serious eye injury.
- Contact your local “diggers hot line” if available in your area, and/or the utility companies directly. Have them mark all underground utilities.

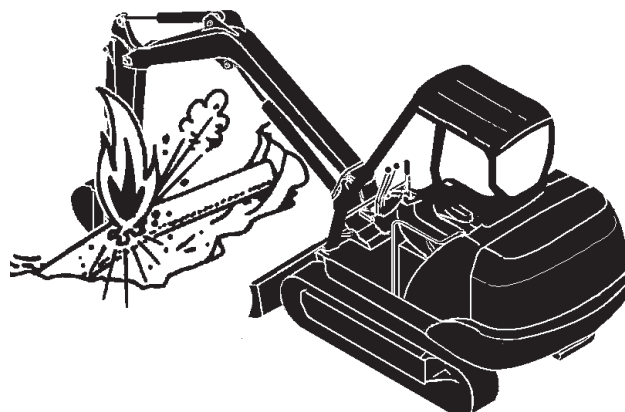

SA-672

Operate With Caution

- If the front attachment or any other part of the machine hits against an overhead obstacle, such as a bridge, both the machine and the overhead obstacle will be damaged, and personal injury may result as well.
- Take care to avoid hitting overhead obstacles with the boom or arm.

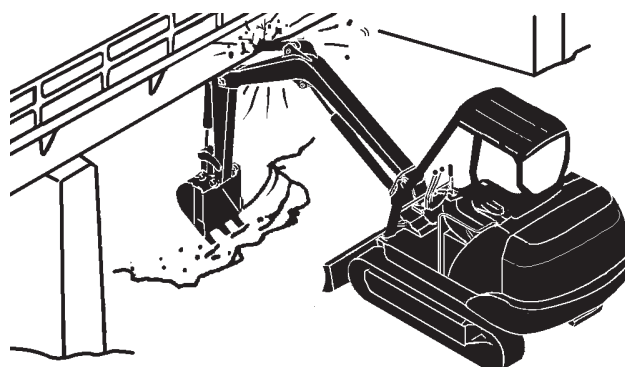

SA-673

Avoid Power Lines

- Serious injury or death can result if the machine or front attachments are not kept a safe distance from electric lines.
- When operating near an electric line, NEVER move any part of the machine or load closer than 3 m (10 ft) plus twice the line insulator length.
- Check and comply with any local regulations that may apply.
- Wet ground will expand the area that could cause any person on it to be affected by electric shock. Keep all bystanders or co-workers away from the site.

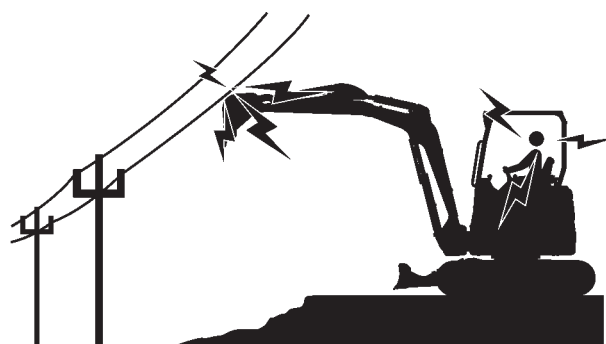

SA-1305

SAFETY

Precautions For Lightning

- The machine is vulnerable to lightning strikes.
 - In the event of an electrical storm, immediately stop operation, and lower the bucket to the ground. Evacuate to a safe place far away from the machine.
 - After the electrical storm has passed, check all of the machine safety devices for any failure. If any failed safety devices are found, operate the machine only after repairing them.



SA-1805

Do Not Use for Craning Operations

- NEVER use the machine for craning operations. If the machine is used for craning operations, the machine may tip over and/or lifted load may fall, possibly resulting in serious injury or death.
- This machine has been exclusively designed to engage in excavation and loading works.
- This machine is not equipped with any of the necessary safety devices that could allow the machine to be used for craning operation.

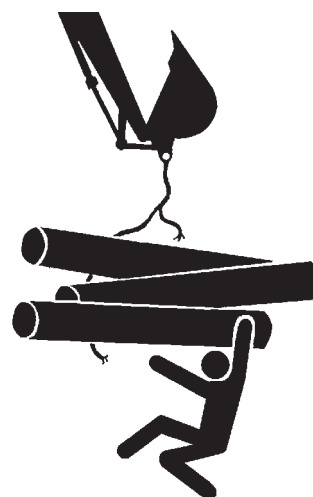

SA-014

Protect Against Flying Debris

- If flying debris such as soil, rock fragments or metal pieces hit eyes or any other part of the body, serious injury may result.
 - Guard against such injuries when working in a job site where possibility of flying pieces of metal or debris exist, or when removing or installing pins using a hammer; wear goggles or safety glasses.
 - Keep bystanders away from the working area before striking any object.

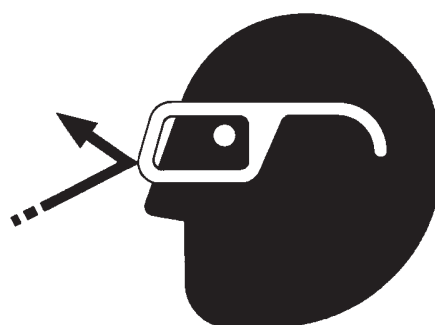

SA-432

SAFETY

Park Machine Safely

- Unless the machine is correctly parked, any hazardous situations such as running away of the machine or damage by vandalism may result, causing the machine to operate unsafely when the engine is restarted. Follow instructions described below when parking the machine.
 - Park the machine on solid level surface to prevent the machine from running away.
 - Lower the bucket and/or blade to the ground.
 - Pull the pilot control shut-off lever to the LOCK position.
 - Turn the auto-idle switch OFF. Failure to do so may create a hazardous condition as the engine speed may unexpectedly increase. (Except ZX27U-3)
 - Run the engine at slow idle speed without load for 5 minutes.
 - Turn key switch to OFF to stop engine. Remove the key from the key switch.
 - Before leaving the machine, close all windows, roof vent, and cab door. Lock all access doors and compartments.



SA-1306

Handle Fluids Safely --- Avoid Fires

- Handle fuel with care; it is highly flammable. If fuel ignites, an explosion and/or a fire may occur, possibly resulting in serious injury or death.
 - Do not refuel the machine while smoking or when near open flame or sparks.
 - Always stop the engine before refueling the machine.
 - Fill the fuel tank outdoors.
- All fuels, most lubricants, and some coolants are flammable.
 - Store flammable fluids well away from fire hazards.
 - Do not incinerate or puncture pressurized containers.
 - Do not store oily rags; they can ignite and burn spontaneously.
 - Securely tighten the fuel and oil filler caps.



SA-018



SA-019

SAFETY

Safety Transporting

- The danger of tipping is present when loading/unloading the machine onto/from a truck or trailer bed.
 - Be sure to observe local regulations when transporting the machine on public roads.
 - Provide an appropriate truck or trailer for transporting the machine.
 - Be sure to have a signal person.
 - Take the following precautions when loading/unloading the machine.
 1. Select firm level ground.
 2. Be sure to use a loading dock or ramp strong enough to support the machine weight.
 3. Ramps must be sufficient in width, length, and strength. Be sure that the incline of the ramp is less than 15 degrees.
 4. Loading docks must be sufficient in width and strength to support the machine and have a gradient of less than 15 degrees.
 5. Be sure to turn the auto-idle switch (13) OFF. (Except ZX27U-3)
 6. Slowly drive the machine.
 7. Avoid steering while driving up or down the ramp as it is extremely dangerous. If steering is unavoidable, first move back to the ground or flatbed, modify traveling direction, and begin to drive again.
 8. The top end of the ramp where it meets the flatbed is a sudden bump. Take care when traveling over it.
 9. Wedge the front and rear of the tracks. Securely fasten the machine to the trailer bed with chains or cables.
 10. Do not operate any levers besides the travel levers when driving up or down the ramp.
 11. Prevent possible injury from machine tipping while the upperstructure is rotating.
 12. Keep the arm tucked under and rotate the upperstructure slowly for best stability.

Refer to “transporting” chapter in this manual for details.

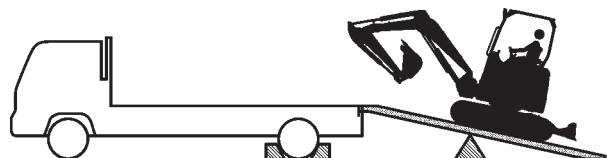

SA-1307

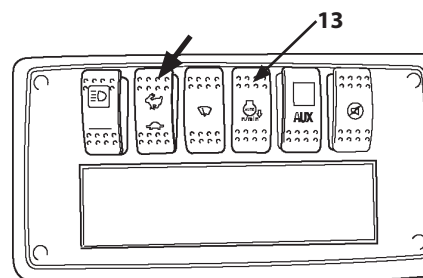

ZX30U-3, 35U-3 40U-3, 50U-3 (Cab)

M1NE-01-009

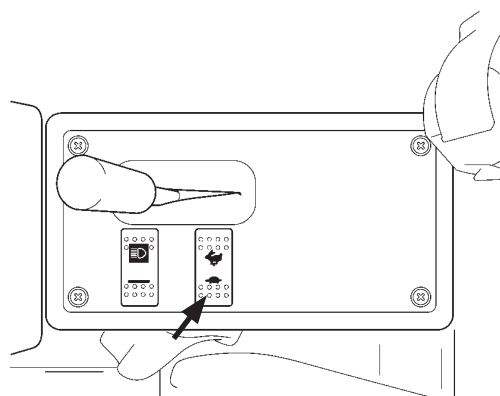

ZX27U-3 (Canopy)

M1M7-01-033

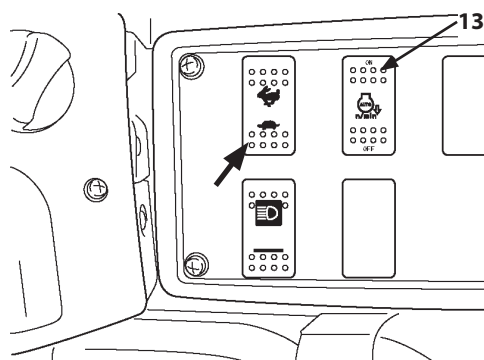

ZX30U-3, 35U-3, 40U-3, 50U-3
(Canopy)

M1NE-01-010

This as a preview PDF file from best-manuals.com



Download full PDF manual at best-manuals.com