

# 350GLC Excavator

(PIN: 1FF350GX\_\_E808001— )

(PIN: 1FF350GX\_\_D808001— )

(PIN: 1FF350GX\_\_C808001— )



## OPERATOR'S MANUAL

### 350GLC Excavator

OMT289050 ISSUE I1 (ENGLISH)

#### CALIFORNIA

##### Proposition 65 Warning

Diesel engine exhaust and some of its constituents are known to the State of California to cause cancer, birth defects, and other reproductive harm.

If this product contains a gasoline engine:

#### **WARNING**

The engine exhaust from this product contains chemicals known to the State of California to cause cancer, birth defects or other reproductive harm.

The State of California requires the above two warnings.

Additional Proposition 65 Warnings can be found in this manual.

**Worldwide Construction  
And Forestry Division**

PRINTED IN U.S.A.

# Introduction

## Foreword

READ THIS MANUAL carefully to learn how to operate and service machine correctly. Personal injury or equipment damage can result if manual is not read. This manual and safety signs on the machine may also be available in other languages; see an authorized John Deere dealer to order.

THIS MANUAL SHOULD BE CONSIDERED a permanent part of the machine and should remain with machine when machine is sold.

MEASUREMENTS in this manual are given in both metric and customary U.S. unit equivalents. Use only correct replacement parts and fasteners. Metric and inch fasteners may require a specific metric or inch wrench.

RIGHT-HAND AND LEFT-HAND sides are determined by facing in the direction of forward travel.

WRITE PRODUCT IDENTIFICATION NUMBERS (P.I.N.) in the Machine Numbers section. Accurately record all the numbers to help in tracing the machine if machine is ever stolen. A dealer also needs these numbers when parts are ordered. File the identification numbers in a secure place off machine.

WARRANTY is provided as part of John Deere's support program for customers who operate and maintain their equipment as described in this manual. The warranty is explained on the warranty certificate or statement which should have been received from the dealer.

This warranty provides the assurance that John Deere backs the products where defects appear within the warranty period. In some circumstances, John Deere also provides field improvements, often without charge to the customer, even if the product is out of warranty. Should the equipment be abused, or modified to change its performance beyond the original factory specifications, the warranty will become void and field improvements may be denied. Setting fuel delivery above specifications or otherwise overpowering machines results in such action.

If current owner is not the original owner of this machine, contact an authorized John Deere dealer to inform them of this unit's serial number. This will help John Deere notify current owner of any issues or product improvements.

TX,FOREWORD -19-30APR20-1/1

### Manual Identification—READ THIS FIRST!

**IMPORTANT:** Use only supporting manuals designated for your specific machine. If incorrect manual is chosen, improper service may occur. Verify product identification number (PIN) when choosing the correct manual.

#### Choosing the Correct Supporting Manuals

John Deere excavators are available in different machine configurations based on the various markets into which they are sold. Different supporting manuals exist for different machine configurations.

When necessary, product identification numbers are listed on the front covers of excavator manuals. These numbers are used to identify the correct supporting manual for your machine.

#### Product Identification Number

The product identification number (PIN) plate (1) is located on the front, right corner of the cab. Each machine has a 17-character PIN (2) shown on PIN plate.

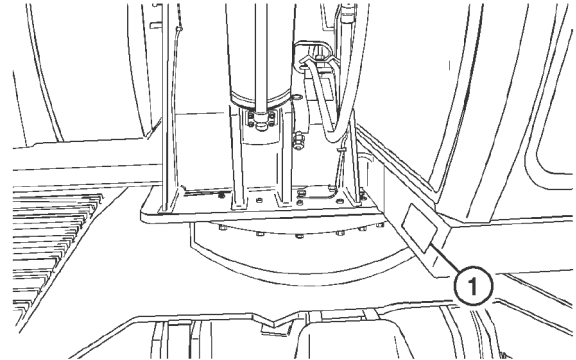

PIN Plate Location—Early Production

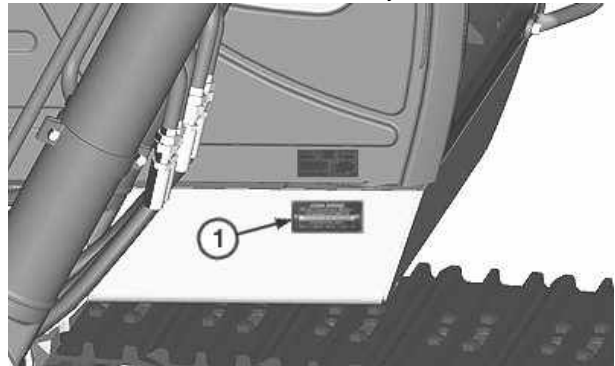

PIN Plate Location—Late Production

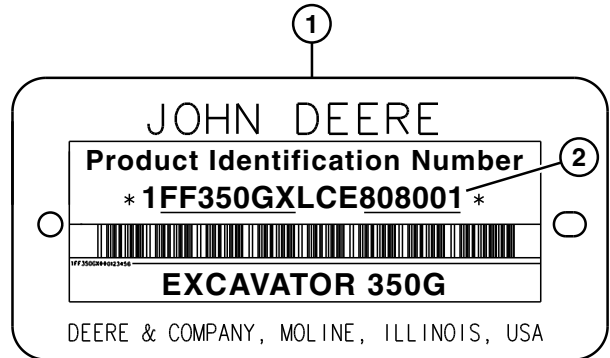

Example of PIN Plate

1—PIN Plate

2—17-Character PIN

TX1160624—UN—13MAY14

TX1156411—UN—27MAR14

TX1160850—UN—20MAY14

Introduction

The PIN identifies the producing factory, machine model number, machine option, year of manufacture, engine emission level, and machine serial number.

The following is an example for a machine that meets Interim Tier 4 and Stage III B emission levels:

17-Character PIN Examples																
1	2	3	4	5	6	7	8	9	10	11	12	13	14	15	16	17
1	F	F	3	5	0	G	X	-	-	E	8	0	8	0	0	1

• **(1—3) World Code:** Identifies location where machine is manufactured.

- 1FF ..... **World Code** (manufacturing location)
- 1DW ..... Davenport Works
- 1T8 ..... Thibodaux Works
- 1T0 ..... Dubuque Works
- 1FF ..... Deere—Hitachi (Kernersville, NC, USA)
- 1F9 ..... Deere—Hitachi (Indaiatuba, São Paulo, Brazil)

• **(4—8) Machine Model Identifier:** Identifies model number.

350G ..... **Machine Model Identifier**

*NOTE: Characters 7—8 identify series and major machine configuration options. These characters will change from one machine to another.*

- X ..... **Machine Option Code**
- X ..... Base Machine
- R ..... HYEX Military Excavators

• **(9) Check Letter:** This is a random character assigned by the factory. This is not used in machine identification.

- ..... **Check Letter** (variable)

• **(10) Manufacturing Year Code:** Identifies year of machine manufacture.

- ..... **Manufacturing Year Code** (variable)
- C ..... 2012
- D ..... 2013
- E ..... 2014
- F ..... 2015

• **(11) Engine Emission Code:** Represents engine emission certification.

- E ..... **Engine Emission Code**
- C ..... Tier 2 and Stage II
- D ..... Tier 3 and Stage III A
- E ..... Interim Tier 4 and Stage III B
- F ..... Final Tier 4 and Stage IV

• **(12—17) Machine Serial Number:** Identifies machine serial number. This character will change from one machine to another.

808001 ..... **Machine Serial Number**

KR46761,0000C4E -19-21MAY14-2/2

**IMPORTANT**

Warranty will not apply to engine and drivetrain failures resulting from unauthorized adjustments to this engine.

Unauthorized adjustments are in violation of the emissions regulations applicable to this engine and may result in substantial fines and penalties.

VD76477,000104D -19-27JUN12-1/1

## License Agreement for John Deere Software

### LICENSE AGREEMENT FOR JOHN DEERE SOFTWARE

**IMPORTANT -- READ CAREFULLY:** THIS LICENSE AGREEMENT IS A LEGAL CONTRACT BETWEEN YOU AND JOHN DEERE SHARED SERVICES, INC., A CORPORATION HAVING A PRINCIPAL ADDRESS OF ONE JOHN DEERE PLACE, MOLINE, IL 61265 (THE "LICENSOR"). THIS LICENSE AGREEMENT GOVERNS YOUR USE OF ANY SOFTWARE ("SOFTWARE") AND OTHER MATERIALS (INDIVIDUALLY OR COLLECTIVELY "LICENSED MATERIALS" OR "LM") ASSOCIATED WITH ANY DISPLAY, ENGINE CONTROL UNIT, INVERTER, CONTROLLER, ELECTRONICS MODULE, SENSOR, ACTUATOR, OR COMPUTING UNIT (INDIVIDUALLY OR COLLECTIVELY "LICENSED PRODUCTS" OR "LP") OF THE JOHN DEERE EQUIPMENT THAT IS NOT OTHERWISE LICENSED BY A SEPARATE WRITTEN AGREEMENT BETWEEN YOU AND LICENSOR, OR ITS AFFILIATES.

BY ACTIVATING OR OTHERWISE USING THE LP, YOU ARE ACCEPTING AND AGREEING TO THE TERMS OF THIS LICENSE AGREEMENT WITH RESPECT TO THE LM THAT HAVE BEEN PRE-INSTALLED ON YOUR LP. YOU AGREE THAT THIS LICENSE AGREEMENT, INCLUDING THE WARRANTY DISCLAIMERS, LIMITATIONS OF LIABILITY, TERMINATION, AND ARBITRATION PROVISIONS BELOW, IS BINDING UPON YOU, AND UPON ANY COMPANY ON WHOSE BEHALF YOU USE THE LM AND LP AS WELL AS THE EMPLOYEES OF ANY SUCH COMPANY (COLLECTIVELY REFERRED TO AS "YOU" IN THIS LICENSE AGREEMENT). IF YOU DO NOT AGREE TO THE TERMS OF THIS LICENSE AGREEMENT, OR IF YOU ARE NOT AUTHORIZED TO ACCEPT THESE TERMS ON BEHALF OF YOUR COMPANY OR ITS EMPLOYEES, DECLINE THESE TERMS AND CONDITIONS AND DO NOT USE THE LP OR THE JOHN DEERE EQUIPMENT. THIS LICENSE AGREEMENT REPRESENTS THE ENTIRE AGREEMENT CONCERNING THE LM BETWEEN YOU AND THE LICENSOR AND IT REPLACES ANY PRIOR PROPOSAL, REPRESENTATION, OR UNDERSTANDING BETWEEN YOU AND THE LICENSOR.

1. **Description of Software.** Your Licensed Product ("LP") comes with all Software pre-installed for operation of your John Deere Equipment. Licensed Materials ("LM") shall mean any Software, data files, documentation, engine calibration tables, proprietary data messages, and controller area network (CAN) data messages that are in or communicated to or from any LP (e.g., to monitor, diagnose, or operate the John Deere Equipment). Data files shall include but not be limited to any data structure that adjusts engine control parameters, such as fuel metering, fuel injection rate, fuel injection timing, fuel pressure, engine speed versus torque relationship, intake boost pressure, fuel-to-air ratio or engine timing.

2. **License.** Licensor hereby grants to you, and you accept, a nonexclusive license to use the LM in machine-readable, object code form, only as authorized in this License Agreement and the applicable provisions of the Operators' Manuals, which you agree to review carefully prior to using the LM. The LM may be used only on the LP in which it was initially installed and solely in conjunction with the John Deere Equipment in which it was initially installed; or, in the event of the inoperability of that LP, on a replacement LP provided to you by an authorized dealer pursuant to the Limited Warranty of Section 5. You agree that you will not assign, sublicense, transfer, pledge, lease, rent, or share your rights under this License Agreement, except that you may permanently transfer all of your rights under this License Agreement in connection with the sale of the LP or John Deere Equipment on which the LM covered by this Agreement are installed. If you sell or otherwise transfer the ownership of the LP or John Deere Equipment, you agree that you will require such transferee to accept terms no less restrictive than those in this License Agreement. This License Agreement also covers any and all hardware and additional software that may interact with the LM and/or the LP.

3. **Licensor's Rights.** You acknowledge and agree that the LM are proprietary to Licensor, or its affiliates or licensors, and is protected under copyright law, trade secret law, and laws governing confidential information. You shall maintain the confidentiality of the LM, any nonpublic information in the LM and the source code of the Software, regardless of whether the LM is labeled or marked with any proprietary legend or notice that

indicates its confidential nature. You further acknowledge and agree that all right, title, and interest in and to the Software and the LM, including associated intellectual property rights, are and shall remain with Licensor, its affiliates, and their licensors. This License Agreement does not convey to you any title or interest in or to the LM, but only a limited right of use revocable in accordance with the terms of this License Agreement.

4. **License Restrictions, Reverse Engineering.** You may not reproduce, prepare derivative works based on, disclose, publish, distribute, rent, lease, modify, loan, display, or perform the LM or any part thereof. You may not reverse engineer, decompile, translate, adapt, or disassemble the LM, nor shall you attempt to create the source code from the object code for the Software. You may not transmit the LM over any network or via a hacking device, although you may use the LM to make transmissions of diagnostic data messages that are authorized by Licensor and you may receive Software updates authorized by Licensor over any Licensor-authorized communications channel. You also agree not to permit any third party acting under your control to do any of the foregoing activities related to reverse engineering of the Licensed Materials. You agree not to remove or obliterate any copyright, trademark or other proprietary rights notices from the LM, except as expressly permitted in writing by Licensor or its licensors or expressly permitted under applicable law notwithstanding these restrictions.

5. **License Restrictions, Circumvention.** Security measures ("SM") means any of the following: technological measures under the Digital Millennium Copyright Act, copyright protection measures, application enabling mechanisms, passwords, key codes, encryption or other security devices. You agree that you will not: (a) attempt to defeat a SM or defeat a SM that protects the LM and that would constitute a violation under applicable U.S., U.K. or German law related circumvention of technological measures that protect software, copyrighted works, or other intellectual property rights, (b) purchase, manufacture, design, import, sell or distribute any circumvention or hacking device that is designed to circumvent or hack the LM or LP and that are unlawful to distribute under applicable U.S., U.K. or German law, (c) circumvent a SM that protects the LM if the circumvention can be used to access trade secrets or confidential information that is protected under applicable law; (d) apply circumvention devices or hacking devices to the LM, LP or John Deere Equipment (e.g., to bypass, temporarily or otherwise, one or more LPs) in a manner that violates any environmental

## Introduction

regulations, laws, safety laws, or voluntary safety standards (e.g., ISO standards) that are supported by LPs, LMs, or (e) apply any circumvention devices or hacking devices from any third parties in an attempt to reverse engineer the LM or that could be used to access trade secrets or other confidential information in the LM that is protected under applicable law. You also agree not to permit any third party acting under your control to do any of the foregoing activities related to circumvention of SM.

6. **Consideration, License Fees.** The license fees or other good and valuable consideration paid by you are paid in consideration of the licenses granted under this License Agreement.

7. **Limited Warranty.** Licensor warrants, for your benefit alone and not for the benefit of any other party, that during the "Warranty Period" defined below, the Software will operate substantially in accordance with the applicable functional specifications ("Specifications") set forth in the Operators' Manuals. If, prior to expiration of the Warranty Period, the Software fails to perform substantially in accordance with the Specifications, you may return the LP to the place of purchase for repair or replacement of the non-performing Software. As used in this License Agreement, the "Warranty Period" is one (1) year from the date you take delivery of the LP.

8. **DISCLAIMER OF WARRANTIES.** YOU HEREBY AGREE THAT THE LIMITED WARRANTY PROVIDED ABOVE (THE "LIMITED WARRANTY") CONSTITUTES YOUR SOLE AND EXCLUSIVE REMEDY FOR ANY PROBLEM WHATSOEVER WITH THE LM. EXCEPT AS PROVIDED IN THE LIMITED WARRANTY, THE LM IS LICENSED "AS IS," AND LICENSOR, ITS AFFILIATES AND THIRD PARTY SUPPLIERS EXPRESSLY DISCLAIM AND YOU EXPRESSLY WAIVE, RELEASE AND RENOUNCE ALL WARRANTIES ARISING BY LAW OR OTHERWISE WITH RESPECT TO THE LM, INCLUDING, BUT NOT LIMITED TO: ANY IMPLIED WARRANTY OF MERCHANTABILITY OR FITNESS FOR A PARTICULAR PURPOSE; ANY IMPLIED WARRANTY ARISING FROM COURSE OF PERFORMANCE, COURSE OF DEALING OR TRADE USAGE; ANY WARRANTY OF TITLE OR NON-INFRINGEMENT; AND, ANY OTHER WARRANTY ARISING UNDER ANY THEORY OF LAW, INCLUDING TORT, NEGLIGENCE, STRICT LIABILITY, CONTRACT OR OTHER LEGAL OR EQUITABLE THEORY. NO REPRESENTATION OR OTHER AFFIRMATION OF FACT INCLUDING, BUT NOT LIMITED TO, STATEMENTS REGARDING SUITABILITY FOR USE, SHALL BE DEEMED TO BE A WARRANTY BY LICENSOR OR ANY OF ITS AFFILIATES OR THIRD PARTY SUPPLIERS. LICENSOR DOES NOT WARRANT THAT THE LM AND/OR LP IS ERROR-FREE OR WILL OPERATE WITHOUT INTERRUPTION.

9. **LIMITATION OF LIABILITY.** EXCEPT AS SET FORTH IN THE LIMITED WARRANTY, UNDER NO CIRCUMSTANCES SHALL LICENSOR, ITS AFFILIATES OR ITS THIRD PARTY SUPPLIERS BE LIABLE TO YOU OR TO ANY THIRD PARTIES FOR DIRECT, INDIRECT, INCIDENTAL OR CONSEQUENTIAL DAMAGES OF ANY KIND, INCLUDING ANY LOSS OR DAMAGE CAUSED BY THE LM; ANY PARTIAL OR TOTAL FAILURE OF THE LM; PERFORMANCE, NONPERFORMANCE OR DELAYS IN CONNECTION WITH

ANY INSTALLATION, MAINTENANCE, WARRANTY OR REPAIRS OF THE LM, DAMAGES FOR CROP LOSS, DAMAGE TO LAND, DAMAGE TO MACHINES, LOST PROFITS, LOSS OF BUSINESS OR LOSS OF GOODWILL, LOSS OF USE OF EQUIPMENT OR SERVICES OR DAMAGES TO BUSINESS OR REPUTATION ARISING FROM THE PERFORMANCE OR NON-PERFORMANCE OF ANY ASPECT OF THE SOFTWARE, LM OR LP, WHETHER IN CONTRACT, TORT OR OTHERWISE, AND WHETHER OR NOT LICENSOR, ITS AFFILIATES OR ITS THIRD PARTY SUPPLIERS HAVE BEEN ADVISED OF THE POSSIBILITY OF SUCH DAMAGES. IN NO EVENT SHALL LICENSOR'S CUMULATIVE LIABILITY TO YOU OR TO ANY OTHER PARTY FOR ANY LOSSES OR DAMAGES RESULTING FROM ANY CLAIMS, LAWSUITS, DEMANDS, OR ACTIONS ARISING FROM OR RELATING TO USE OF THE LM EXCEED YOUR TOTAL PAYMENT FOR THE LP AND FOR THE LICENSE OF THE LM.

10. **Software Maintenance.** Licensor may, at its sole option, offer you maintenance of the Software, even though the Warranty Period has expired. Such maintenance may include providing modifications, corrections or enhancements ("Upgrades") to the Software and/or the applicable Operators' Manuals. Licensor reserves the right, in its sole discretion, to charge you for maintenance (except in cases where corrections are provided under the Limited Warranty). Your acceptance of this License Agreement constitutes your agreement that any Upgrades will be deemed included in the Software as defined in this License Agreement and that they shall be governed by the terms and conditions applicable to the LM under this License Agreement.

11. **Termination of License.** Licensor may terminate the license granted under this License Agreement upon written notice of termination provided to you if you violate any material term of this License Agreement pertaining to your use of the LM or Licensor's rights, including, without limitation, the provisions of Sections 2 and 3 above.

12. **Compliance with Law.** You agree that you will use the LM in accordance with United States law and the laws of the country in which you are located, as applicable, including foreign trade control laws and regulations. The LM may be subject to export and other foreign trade controls restricting re-sales and/or transfers to other countries and parties. By accepting the terms of this License Agreement, you acknowledge that you understand that the LM may be so controlled, including, but not limited to, by the Export Administration Regulations and/or the foreign trade control regulations of the Treasury Department of the United States. The LM remains subject to applicable U.S. laws.

11. **Indemnification.** You agree to defend, indemnify and hold Licensor, its affiliates and third party supplier, and their, officers, directors, employees, agents and representatives (each an "Indemnified Party"), harmless from and against all claims, demands proceedings, injuries, liabilities, losses, or costs and expenses (including reasonable legal fees) brought by any third party against any such persons arising from or in connection with your use of the LM, regardless of whether such losses are caused, wholly or partially, by any negligence, breach of contract or other fault of an Indemnified Party.

12. **Trademark.** Licensor does not grant you any right, license, or interest to any Licensor trademarks, symbols, marks or names (collectively "Marks") or any trademarks that confusingly similar to the Marks and you agree that no such right, license, or interest shall be asserted by you with respect to such Marks.

13. **Costs of Litigation.** If any claim or action is brought by either party to this License Agreement against the other party regarding the subject matter hereof, the prevailing party shall be entitled to recover, in

## Introduction

addition to any other relief granted, reasonable attorney, arbitrators, and dispute resolution center administrative fees and expenses of litigation.

14. **Severability and Waiver.** Should any term or provision of this License Agreement be declared void or unenforceable by any court of competent jurisdiction, such declaration shall have no effect on the remaining terms and remaining provisions hereof. The failure of either party to enforce any rights granted hereunder or to take action against the other party in the event of any breach hereunder shall not be deemed a waiver by that party as to subsequent enforcement of rights of subsequent actions in the event of future breaches.

15. **Language Clause.** Unless the laws of the location in which you reside require otherwise, the parties hereby acknowledge that they have required this License Agreement, and all other documents relating hereto, be drawn up in the English language only. There may be a translated version of this License Agreement. If there is an inconsistency or contradiction between the translated version and the English version of this License Agreement, the English version of this License Agreement shall control unless the laws of the location in which you reside require that a different version control. The parties acknowledge and agree that they have required that this agreement be prepared in the English language. Les parties reconnaissent avoir exigé que les présentes soient rédigées en langue anglaise.

16. **Assignment by Licensor.** Licensor may assign this License Agreement without your prior consent to any company or entity affiliated with Licensor, or by an assignment associated with a corporate restructuring, merger or acquisition.

17. **Governing Law and Forum.** This License Agreement will be governed by and construed in accordance with the substantive laws in force in the State of Illinois, U.S.A. The respective courts of Rock Island County, Illinois have exclusive jurisdiction over all disputes relating to this License Agreement. This License Agreement will not be governed by the conflict of law rules of any jurisdiction or the United Nations Convention on Contracts for the International Sale of Goods, the application of which is expressly excluded.

18. **Arbitration.** IF YOU RESIDE IN A JURISDICTION WHEREIN THE ENFORCEABILITY OF THE TERMS OF SECTION 17 IS DEPENDENT UPON THE PARTIES AGREEING TO SUBMIT TO ARBITRATION, THEN ANY CONTROVERSY OR CLAIM ARISING OUT OF OR RELATING TO THIS LICENSE AGREEMENT SHALL BE DETERMINED BY ARBITRATION IN ACCORDANCE WITH THE INTERNATIONAL ARBITRATION RULES OF THE INTERNATIONAL CENTRE FOR DISPUTE RESOLUTION ("ICDR") IN EFFECT AT THE TIME OF ITS INITIATION. THE ARBITRATION SHALL BE HELD BEFORE ONLY ONE ARBITRATOR APPOINTED BY THE ICDR. THE PLACE OF ARBITRATION SHALL BE CHICAGO, ILLINOIS, USA AND THE LANGUAGE OF THE ARBITRATION SHALL BE ENGLISH.

19. **Representations of Licensee.** BY ACCEPTING THIS AGREEMENT, YOU: (A) ACKNOWLEDGE THAT YOU HAVE READ AND UNDERSTAND THIS AGREEMENT; (B)

REPRESENT THAT YOU HAVE THE AUTHORITY TO ENTER INTO THIS AGREEMENT; (C) AGREE THAT THIS AGREEMENT IS ENFORCEABLE AGAINST YOU AND ANY LEGAL ENTITY THAT OBTAINED THE LM AND ON WHOSE BEHALF IT IS USED; AND, (D) AGREE TO PERFORM THE OBLIGATIONS OF THIS AGREEMENT.

20. **Notices.** All notices to Licensor shall be sent by certified or registered mail to John Deere Shared Services, Inc., One John Deere Place, Moline, IL 61265 U.S.A. All notices to Licensor shall be effective upon receipt. All notices required to be given to you shall, in Licensor's sole discretion, either be sent via certified or registered mail to the address given to Licensor, a John Deere dealer, or another distribution partner of Licensor in connection with your purchase of the LP and/or John Deere Equipment. Either method of notification used by Licensor shall be effective upon dispatch. You agree to notify Licensor of any change in your address in the manner set forth above.

21. **Third Party Software Notifications and Licenses.** The copyrights for certain portions of the Software may be owned or licensed by other third parties ("Third Party Software") and used and distributed under license. The Third Party Notices includes the acknowledgements, notices and licenses for the Third Party Software. The Third Party Notices are included with the distribution of this License Agreement on the display. If you are unable to locate these Third Party Notices, please write to us at the address below. The Third Party Software is licensed according to the applicable Third Party Software license notwithstanding anything to the contrary in this Agreement. If the Third Party Software contains copyrighted software that is licensed under the GPL/LGPL or other copyleft licenses, copies of those licenses are included in the Third Party Notices. You may obtain the complete corresponding source code for such Third Party Software from us for a period of three years after our last shipment of the Software by sending a request letter to:

Deere Open Source Compliance Team  
P.O. Box 1202  
Moline, IL 61266-1202  
USA

Please include name of the product and the version number of the software in the request letter. This offer is valid to anyone in receipt of this information.

## Emissions Control System Certification Label

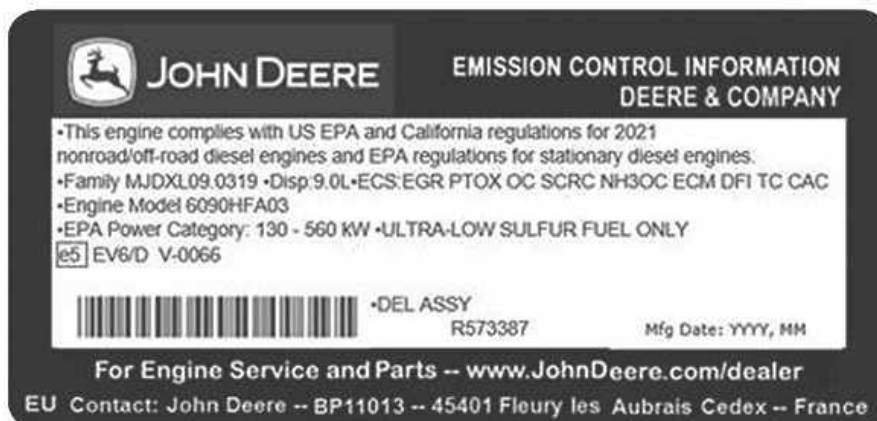

Engine Emissions Label

**⚠ CAUTION: Statutes providing severe penalties for tampering with emissions controls may apply to the user or dealer.**

The emissions warranty applies to those engines marketed by John Deere that have been certified by the United States Environmental Protection Agency (EPA) and/or California Air Resources Board (CARB); and used in the United States and Canada in Non-road equipment. The presence of an emissions label like the one shown signifies that the engine has been certified with the EPA and/or CARB. The EPA and CARB warranties only apply to new engines having the certification label affixed to the engine and sold as stated above in the geographic areas. The presence of an EU number signifies that the engine has been certified with the European Union countries per Regulation (EU) 2016/1628 and supplementing legislation. The EPA and/or CARB emissions warranties do not apply to the EU countries.

The emissions label has applicable US EPA and/or CARB regulatory year. The regulatory year determines which warranty statement is applicable to engine. See “EPA Non-road Emissions Control Warranty Statement—Compression Ignition” and “CARB Non-road Emissions Control Warranty Statement—Compression Ignition”. For additional regulatory year warranty statements, see [www.JohnDeere.com](http://www.JohnDeere.com) or contact the nearest John Deere service dealer for assistance.

**Emission Control System(s) Laws**

The U.S. EPA and California ARB prohibit the removal or rendering inoperative of any device or element of design installed on or in engines/equipment in compliance with applicable emission regulations prior to or after the sale and delivery of the engines/equipment to the ultimate purchaser.

DX,EMISSIONS,LABEL -19-05FEB21-1/1

RG33429 —UN—04FEB21



## EPA Non-road Emissions Control Warranty Statement—Compression Ignition

DXLOGOV1 —UN—28APR09



**JOHN DEERE**

### U.S. AND CANADA EMISSION CONTROL WARRANTY STATEMENT YOUR WARRANTY RIGHTS AND OBLIGATIONS

To determine if the John Deere engine qualifies for the additional warranties set forth below, look for the "Emissions Control Information" label located on the engine. If the engine is operated in the United States or Canada and the Emissions Control information label states: "This engine complies with US EPA regulations for nonroad and stationary diesel engines", or "This engine conforms to US EPA nonroad compression-ignition regulations", refer to the "U.S. and Canada Emission Control Warranty Statement." If the engine is operated in California, and the label states: "This engine complies with US EPA and CARB regulations for nonroad diesel engines", or "This engine conforms to US EPA and California nonroad compression-ignition emission regulations", also refer to the "California Emission Control Warranty Statement."

Warranties stated on this certificate refer only to emissions-related parts and components of your engine. The complete engine warranty, less emissions-related parts and components, is provided separately. If you have any questions about your warranty rights and responsibilities, you should contact John Deere at 1-319-292-5400.

#### JOHN DEERE'S WARRANTY RESPONSIBILITY

John Deere warrants to the ultimate purchaser and each subsequent purchaser that this off-road diesel engine including all parts of its emission-control system was designed, built and equipped so as to conform at the time of the sale with Section 213 of the Clean Air Act and is free from defects in materials and workmanship which would cause the engine to fail to conform with applicable US EPA regulations for a period of five years from the date the engine is placed into service or 3,000 hours of operation, whichever first occurs.

Where a warrantable condition exists, John Deere will repair or replace, as it elects, any part or component with a defect in materials or workmanship that would increase the engine's emissions of any regulated pollutant within the stated warranty period at no cost to you, including expenses related to diagnosing and repairing or replacing emission-related parts. Warranty coverage is subject to the limitations and exclusions set forth herein. Emission-related components include engine parts developed to control emissions related to the following:

Air-Induction System

Fuel System

Ignition System

Exhaust Gas Recirculation Systems

Aftertreatment Devices

Crankcase Ventilation Valves

Sensors

Engine Electronic Control Units

#### EMISSION WARRANTY EXCLUSIONS

John Deere may deny warranty claims for malfunctions or failures caused by:

- Non-performance of maintenance requirements listed in the Operator's Manual
- The use of the engine/equipment in a manner for which it was not designed
- Abuse, neglect, improper maintenance or unapproved modifications or alterations
- Accidents for which it does not have responsibility or by acts of God

The off-road diesel engine is designed to operate on diesel fuel as specified in the Fuels, Lubricants and Coolants section in the Operators Manual. Use of any other fuel can harm the emissions control system of the engine/equipment and is not approved for use.

To the extent permitted by law John Deere is not liable for damage to other engine components caused by a failure of an emission-related part, unless otherwise covered by standard warranty.

**THIS WARRANTY IS EXPRESSLY IN LIEU OF ANY OTHER WARRANTIES, EXPRESS OR IMPLIED, INCLUDING ANY WARRANTY OF MERCHANTABILITY OR FITNESS FOR A PARTICULAR PURPOSE. REMEDIES UNDER THIS WARRANTY ARE LIMITED TO THE PROVISIONS OF MATERIAL AND SERVICES AS SPECIFIED HEREIN. WHERE PERMITTED BY LAW, NEITHER JOHN DEERE NOR ANY AUTHORIZED JOHN DEERE ENGINE DISTRIBUTOR, DEALER, OR REPAIR FACILITY OR ANY COMPANY AFFILIATED WITH JOHN DEERE WILL BE LIABLE FOR INCIDENTAL OR CONSEQUENTIAL DAMAGES.**

Emission\_CI\_EPA (18Dec09)

Continued on next page

DX,EMISSIONS,EPA -19-12DEC12-1/2

## Introduction



**JOHN DEERE**

### **U.S. AND CANADA EMISSION CONTROL WARRANTY STATEMENT YOUR WARRANTY RIGHTS AND OBLIGATIONS**

To determine if the John Deere engine qualifies for the additional warranties set forth below, look for the "Emissions Control Information" label located on the engine. If the engine is operated in the United States or Canada and the Emissions Control information label states: "This engine complies with US EPA regulations for nonroad and stationary diesel engines", or "This engine conforms to US EPA nonroad compression-ignition regulations", refer to the "U.S. and Canada Emission Control Warranty Statement." If the engine is operated in California, and the label states: "This engine complies with US EPA and CARB regulations for nonroad diesel engines", or "This engine conforms to US EPA and California nonroad compression-ignition emission regulations", also refer to the "California Emission Control Warranty Statement."

Warranties stated on this certificate refer only to emissions-related parts and components of your engine. The complete engine warranty, less emissions-related parts and components, is provided separately. If you have any questions about your warranty rights and responsibilities, you should contact John Deere at 1-319-292-5400.

#### **JOHN DEERE'S WARRANTY RESPONSIBILITY**

John Deere warrants to the ultimate purchaser and each subsequent purchaser that this off-road diesel engine including all parts of its emission-control system was designed, built and equipped so as to conform at the time of the sale with Section 213 of the Clean Air Act and is free from defects in materials and workmanship which would cause the engine to fail to conform with applicable US EPA regulations for a period of five years from the date the engine is placed into service or 3,000 hours of operation, whichever first occurs.

Where a warrantable condition exists, John Deere will repair or replace, as it elects, any part or component with a defect in materials or workmanship that would increase the engine's emissions of any regulated pollutant within the stated warranty period at no cost to you, including expenses related to diagnosing and repairing or replacing emission-related parts. Warranty coverage is subject to the limitations and exclusions set forth herein. Emission-related components include engine parts developed to control emissions related to the following:

Air-Induction System	Aftertreatment Devices
Fuel System	Crankcase Ventilation Valves
Ignition System	Sensors
Exhaust Gas Recirculation Systems	Engine Electronic Control Units

#### **EMISSION WARRANTY EXCLUSIONS**

John Deere may deny warranty claims for malfunctions or failures caused by:

- Non-performance of maintenance requirements listed in the Operator's Manual
- The use of the engine/equipment in a manner for which it was not designed
- Abuse, neglect, improper maintenance or unapproved modifications or alterations
- Accidents for which it does not have responsibility or by acts of God

The off-road diesel engine is designed to operate on diesel fuel as specified in the Fuels, Lubricants and Coolants section in the Operators Manual. Use of any other fuel can harm the emissions control system of the engine/equipment and is not approved for use.

To the extent permitted by law John Deere is not liable for damage to other engine components caused by a failure of an emission-related part, unless otherwise covered by standard warranty.

**THIS WARRANTY IS EXPRESSLY IN LIEU OF ANY OTHER WARRANTIES, EXPRESS OR IMPLIED, INCLUDING ANY WARRANTY OF MERCHANTABILITY OR FITNESS FOR A PARTICULAR PURPOSE. REMEDIES UNDER THIS WARRANTY ARE LIMITED TO THE PROVISIONS OF MATERIAL AND SERVICES AS SPECIFIED HEREIN. WHERE PERMITTED BY LAW, NEITHER JOHN DEERE NOR ANY AUTHORIZED JOHN DEERE ENGINE DISTRIBUTOR, DEALER, OR REPAIR FACILITY OR ANY COMPANY AFFILIATED WITH JOHN DEERE WILL BE LIABLE FOR INCIDENTAL OR CONSEQUENTIAL DAMAGES.**

Emission\_CI\_EPA (18Dec09)

TS1721—UN—15JUL13

DX,EMISSIONS,EPA -19-12DEC12-2/2

## CARB Non-road Emissions Control Warranty Statement—Compression Ignition

### Emissions Control Warranty Statement 2019 through 2021

DXLOGOV1 —UN—28APR09



**JOHN DEERE**

#### **CALIFORNIA EMISSIONS CONTROL WARRANTY STATEMENT YOUR WARRANTY RIGHTS AND OBLIGATIONS**

To determine if the John Deere engine qualifies for the additional warranties set forth below, look for the “Emission Control Information” label located on the engine. If the engine is operated in the United States or Canada and the engine label states: “This engine complies with US EPA regulations for nonroad and stationary diesel engines”, or “This engine complies with US EPA regulations for stationary emergency diesel engines”, refer to the “U.S. and Canada Emission Control Warranty Statement.” If the engine is operated in California, and the engine label states: “This engine complies with US EPA and CARB regulations for nonroad diesel engines” also refer to the “California Emissions Control Warranty Statement.”

Warranties stated on this certificate refer only to emissions-related parts and components of your engine. The complete engine warranty, less emission-related parts and components, is provided separately. If you have any questions about your warranty rights and responsibilities, you should contact John Deere at 1-319-292-5400.

#### **CALIFORNIA EMISSIONS CONTROL WARRANTY STATEMENT:**

The California Air Resources Board (CARB) is pleased to explain the emission-control system warranty on 2019 through 2021 off-road diesel engines. In California, new off-road engines must be designed, built and equipped to meet the State’s stringent anti-smog standards. John Deere must warrant the emission control system on your engine for the periods of time listed below provided there has been no abuse, neglect or improper maintenance of your engine.

Your emission control system may include parts such as the fuel injection system and the air induction system. Also included may be hoses, belts, connectors and other emission-related assemblies.

John Deere warrants to the ultimate purchaser and each subsequent purchaser that this off-road diesel engine was designed, built, and equipped so as to conform at the time of sale with all applicable regulations adopted by CARB and is free from defects in materials and workmanship which would cause the failure of a warranted part to be identical in all material respects to the part as described in John Deere’s application for certification for a period of five years from the date the engine is delivered to an ultimate purchaser or 3,000 hours of operation, whichever occurs first for all engines rated at 19 kW and greater. In the absence of a device to measure hours of use, the engine shall be warranted for a period of five years.

#### **EMISSIONS WARRANTY EXCLUSIONS:**

John Deere may deny warranty claims for failures caused by the use of an add-on or modified part which has not been exempted by the CARB. A modified part is an aftermarket part intended to replace an original emission-related part which is not functionally identical in all respects and which in any way affects emissions. An add-on part is any aftermarket part which is not a modified part or a replacement part.

In no event will John Deere, any authorized engine distributor, dealer, or repair facility, or any company affiliated with John Deere be liable for incidental or consequential damage.

## Introduction

### JOHN DEERE'S WARRANTY RESPONSIBILITY:

Where a warrantable condition exists, John Deere will repair or replace, as it elects, your off-road diesel engine at no cost to you, including diagnosis, parts or labor. Warranty coverage is subject to the limitations and exclusions set forth herein. The off-road diesel engine is warranted for a period of five years from the date the engine is delivered to an ultimate purchaser or 3,000 hours of operation, whichever occurs first. The following are emissions-related parts:

#### Air Induction System

- Intake manifold
- Turbocharger
- Charge air cooler

#### Fuel Metering system

- Fuel injection system

#### Exhaust Gas Recirculation

- EGR valve

#### Catalyst or Thermal Reactor Systems

- Catalytic converter
- Exhaust manifold

#### Emission control labels

#### Particulate Controls

- Any device used to capture particulate emissions
- Any device used in the regeneration of the capturing system
- Enclosures and manifolding
- Smoke Puff Limiters

#### Positive Crankcase Ventilation (PCV) System

- PCV valve
- Oil filler cap

#### Advanced Oxides of Nitrogen (NOx) Controls

- NOx absorbers and catalysts

#### SCR systems and urea containers/dispensing systems

#### Miscellaneous Items used in Above Systems

- Electronic control units, sensors, actuators, wiring harnesses, hoses, connectors, clamps, fittings, gasket, mounting hardware

Any warranted emissions-related part scheduled for replacement as required maintenance is warranted by John Deere for the period of time prior to the first scheduled replacement point for the part. Any warranted emissions-related part not scheduled for replacement as required maintenance or scheduled only for regular inspection is warranted by John Deere for the stated warranty period.

### OWNER'S WARRANTY RESPONSIBILITIES:

As the off-road diesel engine owner you are responsible for the performance of the required maintenance listed in your Operator's Manual. John Deere recommends that the owner retain all receipts covering maintenance on the off-road diesel engine, but John Deere cannot deny warranty solely for the lack of receipts or for the owner's failure to ensure the performance of all scheduled maintenance. However, as the off-road diesel engine owner, you should be aware that John Deere may deny you warranty coverage if your off-road diesel engine or a part has failed due to abuse, neglect, improper maintenance or unapproved modifications.

The off-road diesel engine is designed to operate on diesel fuel as specified in the Fuels, Lubricants and Coolants section in the Operators Manual. Use of any other fuel may result in the engine no longer operating in compliance with applicable emissions requirements.

The owner is responsible for initiating the warranty process, and should present the machine to the nearest authorized John Deere dealer as soon as a problem is suspected. The warranty repairs should be completed by the authorized John Deere dealer as quickly as possible.

Emissions regulations require the customer to bring the unit to an authorized servicing dealer when warranty service is required. As a result, John Deere is NOT liable for travel or mileage on emissions warranty service calls.

Emission\_CI\_CARB (01Feb17)

Continued on next page

DX,EMISSIONS,CARB -19-26AUG20-2/8

## Emissions Control Warranty Statement 2019 through 2021

DXLOGOV1 —UN—28APR09



**JOHN DEERE**

### **CALIFORNIA EMISSIONS CONTROL WARRANTY STATEMENT YOUR WARRANTY RIGHTS AND OBLIGATIONS**

To determine if the John Deere engine qualifies for the additional warranties set forth below, look for the "Emission Control Information" label located on the engine. If the engine is operated in the United States or Canada and the engine label states: "This engine complies with US EPA regulations for nonroad and stationary diesel engines", or "This engine complies with US EPA regulations for stationary emergency diesel engines", refer to the "U.S. and Canada Emission Control Warranty Statement." If the engine is operated in California, and the engine label states: "This engine complies with US EPA and CARB regulations for nonroad diesel engines" also refer to the "California Emissions Control Warranty Statement."

Warranties stated on this certificate refer only to emissions-related parts and components of your engine. The complete engine warranty, less emission-related parts and components, is provided separately. If you have any questions about your warranty rights and responsibilities, you should contact John Deere at 1-319-292-5400.

#### **CALIFORNIA EMISSIONS CONTROL WARRANTY STATEMENT:**

The California Air Resources Board (CARB) is pleased to explain the emission-control system warranty on 2019 through 2021 off-road diesel engines. In California, new off-road engines must be designed, built and equipped to meet the State's stringent anti-smog standards. John Deere must warrant the emission control system on your engine for the periods of time listed below provided there has been no abuse, neglect or improper maintenance of your engine.

Your emission control system may include parts such as the fuel injection system and the air induction system. Also included may be hoses, belts, connectors and other emission-related assemblies.

John Deere warrants to the ultimate purchaser and each subsequent purchaser that this off-road diesel engine was designed, built, and equipped so as to conform at the time of sale with all applicable regulations adopted by CARB and is free from defects in materials and workmanship which would cause the failure of a warranted part to be identical in all material respects to the part as described in John Deere's application for certification for a period of five years from the date the engine is delivered to an ultimate purchaser or 3,000 hours of operation, whichever occurs first for all engines rated at 19 kW and greater. In the absence of a device to measure hours of use, the engine shall be warranted for a period of five years.

#### **EMISSIONS WARRANTY EXCLUSIONS:**

John Deere may deny warranty claims for failures caused by the use of an add-on or modified part which has not been exempted by the CARB. A modified part is an aftermarket part intended to replace an original emission-related part which is not functionally identical in all respects and which in any way affects emissions. An add-on part is any aftermarket part which is not a modified part or a replacement part.

In no event will John Deere, any authorized engine distributor, dealer, or repair facility, or any company affiliated with John Deere be liable for incidental or consequential damage.

Continued on next page

DX,EMISSIONS,CARB -19-26AUG20-3/8

RG29280 —UN—02FEB17

## Introduction

### JOHN DEERE'S WARRANTY RESPONSIBILITY:

Where a warrantable condition exists, John Deere will repair or replace, as it elects, your off-road diesel engine at no cost to you, including diagnosis, parts or labor. Warranty coverage is subject to the limitations and exclusions set forth herein. The off-road diesel engine is warranted for a period of five years from the date the engine is delivered to an ultimate purchaser or 3,000 hours of operation, whichever occurs first. The following are emissions-related parts:

#### Air Induction System

- Intake manifold
- Turbocharger
- Charge air cooler

#### Fuel Metering system

- Fuel injection system

#### Exhaust Gas Recirculation

- EGR valve

#### Catalyst or Thermal Reactor Systems

- Catalytic converter
- Exhaust manifold

#### Emission control labels

##### Particulate Controls

- Any device used to capture particulate emissions
- Any device used in the regeneration of the capturing system
- Enclosures and manifolding
- Smoke Puff Limiters

##### Positive Crankcase Ventilation (PCV) System

- PCV valve
- Oil filler cap

#### Advanced Oxides of Nitrogen (NOx) Controls

- NOx absorbers and catalysts

##### SCR systems and urea containers/dispensing systems

##### Miscellaneous Items used in Above Systems

- Electronic control units, sensors, actuators, wiring harnesses, hoses, connectors, clamps, fittings, gasket, mounting hardware

Any warranted emissions-related part scheduled for replacement as required maintenance is warranted by John Deere for the period of time prior to the first scheduled replacement point for the part. Any warranted emissions-related part not scheduled for replacement as required maintenance or scheduled only for regular inspection is warranted by John Deere for the stated warranty period.

### OWNER'S WARRANTY RESPONSIBILITIES:

As the off-road diesel engine owner you are responsible for the performance of the required maintenance listed in your Operator's Manual. John Deere recommends that the owner retain all receipts covering maintenance on the off-road diesel engine, but John Deere cannot deny warranty solely for the lack of receipts or for the owner's failure to ensure the performance of all scheduled maintenance. However, as the off-road diesel engine owner, you should be aware that John Deere may deny you warranty coverage if your off-road diesel engine or a part has failed due to abuse, neglect, improper maintenance or unapproved modifications.

The off-road diesel engine is designed to operate on diesel fuel as specified in the Fuels, Lubricants and Coolants section in the Operators Manual. Use of any other fuel may result in the engine no longer operating in compliance with applicable emissions requirements.

The owner is responsible for initiating the warranty process, and should present the machine to the nearest authorized John Deere dealer as soon as a problem is suspected. The warranty repairs should be completed by the authorized John Deere dealer as quickly as possible.

Emissions regulations require the customer to bring the unit to an authorized servicing dealer when warranty service is required. As a result, John Deere is NOT liable for travel or mileage on emissions warranty service calls.

Emission\_CI\_CARB (01Feb17)

Continued on next page

DX,EMISSIONS,CARB -19-26AUG20-4/8

RG29281 —UN—27FEB17

## Emissions Control Warranty Statement 2022 through 2024

DXLOGOV1 —UN—28APR09



**JOHN DEERE**

### **CALIFORNIA EMISSIONS CONTROL WARRANTY STATEMENT YOUR WARRANTY RIGHTS AND OBLIGATIONS**

To determine if the John Deere engine qualifies for the additional warranties set forth below, look for the "Emission Control Information" label located on the engine. If the engine is operated in the United States or Canada and the engine label states: "This engine complies with US EPA regulations for nonroad and stationary diesel engines", or "This engine complies with US EPA regulations for stationary emergency diesel engines", refer to the "U.S. and Canada Emission Control Warranty Statement." If the engine is operated in California, and the engine label states: "This engine complies with US EPA and California regulations for nonroad/off-road diesel engines" also refer to the "California Emissions Control Warranty Statement."

Warranties stated on this certificate refer only to emissions-related parts and components of your engine. The complete engine warranty, less emission-related parts and components, is provided separately. If you have any questions about your warranty rights and responsibilities, you should contact John Deere at 1-319-292-5400.

#### **CALIFORNIA EMISSIONS CONTROL WARRANTY STATEMENT:**

The California Air Resources Board (CARB) is pleased to explain the emission-control system warranty on 2022 through 2024 off-road diesel engines. In California, new off-road engines must be designed, built and equipped to meet the State's stringent anti-smog standards. John Deere must warrant the emission control system on your engine for the periods of time listed below provided there has been no abuse, neglect or improper maintenance of your engine.

Your emission control system may include parts such as the fuel injection system and the air induction system. Also included may be hoses, belts, connectors and other emission-related assemblies.

John Deere warrants to the ultimate purchaser and each subsequent purchaser that this off-road diesel engine was designed, built, and equipped so as to conform at the time of sale with all applicable regulations adopted by CARB. John Deere warrants that this engine is free from defects in materials and workmanship which would cause the failure of emissions warranted parts to be identical in all material respects to the part as described in John Deere's application for certification for a period of five years from the date the engine is delivered to an ultimate purchaser or 3,000 hours of operation, whichever occurs first. This applies to all engines rated at 19 kW and greater. In the absence of a device to measure hours of use, the engine shall be warranted for a period of five years.

#### **EMISSIONS WARRANTY EXCLUSIONS:**

John Deere may deny warranty claims for failures caused by the use of an add-on or modified part which has not been exempted by the CARB. A modified part is an aftermarket part intended to replace an original emission-related part which is not functionally identical in all respects and which in any way affects emissions. An add-on part is any aftermarket part which is not a modified part or a replacement part.

In no event will John Deere, any authorized engine distributor, dealer, or repair facility, or any company affiliated with John Deere be liable for incidental or consequential damage.

## Introduction

### JOHN DEERE'S WARRANTY RESPONSIBILITY:

Where a warrantable condition exists, John Deere will repair or replace, as it elects, your off-road diesel engine at no cost to you, including diagnosis, parts or labor. Warranty coverage is subject to the limitations and exclusions set forth herein. The off-road diesel engine is warranted for a period of five years from the date the engine is delivered to an ultimate purchaser or 3,000 hours of operation, whichever occurs first. The following are emissions-related parts:

#### Air Induction System

- Intake manifold
- Turbocharger
- Charge air cooler

#### Fuel Metering system

- Fuel injection system

#### Exhaust Gas Recirculation

- EGR valve

#### Catalyst or Thermal Reactor Systems

- Catalytic converter
- Exhaust manifold

#### Emission control labels

#### Particulate Controls

- Any device used to capture particulate emissions
- Any device used in the regeneration of the capturing system
- Enclosures and manifolding
- Smoke Puff Limiters

#### Positive Crankcase Ventilation (PCV) System

- PCV valve
- Oil filler cap

#### Advanced Oxides of Nitrogen (NOx) Controls

- NOx absorbers and catalysts

#### SCR systems and urea containers/dispensing systems

#### Miscellaneous Items used in Above Systems

- Electronic control units, sensors, actuators, wiring harnesses, hoses, connectors, clamps, fittings, gasket, mounting hardware

Any warranted emissions-related part scheduled for replacement as required maintenance is warranted by John Deere for the period of time prior to the first scheduled replacement point for the part. Any warranted emissions-related part not scheduled for replacement as required maintenance or scheduled only for regular inspection is warranted by John Deere for the stated warranty period.

### OWNER'S WARRANTY RESPONSIBILITIES:

As the off-road diesel engine owner you are responsible for the performance of the required maintenance listed in your Operator's Manual. John Deere recommends that the owner retain all receipts covering maintenance on the off-road diesel engine, but John Deere cannot deny warranty solely for the lack of receipts or for the owner's failure to ensure the performance of all scheduled maintenance. However, as the off-road diesel engine owner, you should be aware that John Deere may deny you warranty coverage if your off-road diesel engine or a part has failed due to abuse, neglect, improper maintenance or unapproved modifications.

The off-road diesel engine is designed to operate on diesel fuel as specified in the Fuels, Lubricants and Coolants section in the Operators Manual. Use of any other fuel may result in the engine no longer operating in compliance with applicable emissions requirements.

The owner is responsible for initiating the warranty process, and should present the machine to the nearest authorized John Deere dealer as soon as a problem is suspected. The warranty repairs should be completed by the authorized John Deere dealer as quickly as possible.

Emissions regulations require the customer to bring the unit to an authorized servicing dealer when warranty service is required. As a result, John Deere is NOT liable for travel or mileage on emissions warranty service calls.

Emission\_CI\_CARB (14Apr20)

Continued on next page

DX,EMISSIONS,CARB -19-26AUG20-6/8



**Emissions Control Warranty Statement 2022 through 2024**

DXLOGOV1 —UN—28APR09



**JOHN DEERE**

**CALIFORNIA EMISSIONS CONTROL WARRANTY STATEMENT  
YOUR WARRANTY RIGHTS AND OBLIGATIONS**

To determine if the John Deere engine qualifies for the additional warranties set forth below, look for the "Emission Control Information" label located on the engine. If the engine is operated in the United States or Canada and the engine label states: "This engine complies with US EPA regulations for nonroad and stationary diesel engines", or "This engine complies with US EPA regulations for stationary emergency diesel engines", refer to the "U.S. and Canada Emission Control Warranty Statement." If the engine is operated in California, and the engine label states: "This engine complies with US EPA and California regulations for nonroad/off-road diesel engines" also refer to the "California Emissions Control Warranty Statement."

Warranties stated on this certificate refer only to emissions-related parts and components of your engine. The complete engine warranty, less emission-related parts and components, is provided separately. If you have any questions about your warranty rights and responsibilities, you should contact John Deere at 1-319-292-5400.

**CALIFORNIA EMISSIONS CONTROL WARRANTY STATEMENT:**

The California Air Resources Board (CARB) is pleased to explain the emission-control system warranty on 2022 through 2024 off-road diesel engines. In California, new off-road engines must be designed, built and equipped to meet the State's stringent anti-smog standards. John Deere must warrant the emission control system on your engine for the periods of time listed below provided there has been no abuse, neglect or improper maintenance of your engine.

Your emission control system may include parts such as the fuel injection system and the air induction system. Also included may be hoses, belts, connectors and other emission-related assemblies.

John Deere warrants to the ultimate purchaser and each subsequent purchaser that this off-road diesel engine was designed, built, and equipped so as to conform at the time of sale with all applicable regulations adopted by CARB. John Deere warrants that this engine is free from defects in materials and workmanship which would cause the failure of emissions warranted parts to be identical in all material respects to the part as described in John Deere's application for certification for a period of five years from the date the engine is delivered to an ultimate purchaser or 3,000 hours of operation, whichever occurs first. This applies to all engines rated at 19 kW and greater. In the absence of a device to measure hours of use, the engine shall be warranted for a period of five years.

**EMISSIONS WARRANTY EXCLUSIONS:**

John Deere may deny warranty claims for failures caused by the use of an add-on or modified part which has not been exempted by the CARB. A modified part is an aftermarket part intended to replace an original emission-related part which is not functionally identical in all respects and which in any way affects emissions. An add-on part is any aftermarket part which is not a modified part or a replacement part.

In no event will John Deere, any authorized engine distributor, dealer, or repair facility, or any company affiliated with John Deere be liable for incidental or consequential damage.

Continued on next page

DX,EMISSIONS,CARB -19-26AUG20-7/8

RC32768 —UN—19AUG20

## Introduction

### JOHN DEERE'S WARRANTY RESPONSIBILITY:

Where a warrantable condition exists, John Deere will repair or replace, as it elects, your off-road diesel engine at no cost to you, including diagnosis, parts or labor. Warranty coverage is subject to the limitations and exclusions set forth herein. The off-road diesel engine is warranted for a period of five years from the date the engine is delivered to an ultimate purchaser or 3,000 hours of operation, whichever occurs first. The following are emissions-related parts:

#### Air Induction System

- Intake manifold
- Turbocharger
- Charge air cooler

#### Fuel Metering system

- Fuel injection system

#### Exhaust Gas Recirculation

- EGR valve

#### Catalyst or Thermal Reactor Systems

- Catalytic converter
- Exhaust manifold

#### Emission control labels

#### Particulate Controls

- Any device used to capture particulate emissions
- Any device used in the regeneration of the capturing system
- Enclosures and manifolding
- Smoke Puff Limiters

#### Positive Crankcase Ventilation (PCV) System

- PCV valve
- Oil filler cap

#### Advanced Oxides of Nitrogen (NOx) Controls

- NOx absorbers and catalysts

#### SCR systems and urea containers/dispensing systems

#### Miscellaneous Items used in Above Systems

- Electronic control units, sensors, actuators, wiring harnesses, hoses, connectors, clamps, fittings, gasket, mounting hardware

Any warranted emissions-related part scheduled for replacement as required maintenance is warranted by John Deere for the period of time prior to the first scheduled replacement point for the part. Any warranted emissions-related part not scheduled for replacement as required maintenance or scheduled only for regular inspection is warranted by John Deere for the stated warranty period.

### OWNER'S WARRANTY RESPONSIBILITIES:

As the off-road diesel engine owner you are responsible for the performance of the required maintenance listed in your Operator's Manual. John Deere recommends that the owner retain all receipts covering maintenance on the off-road diesel engine, but John Deere cannot deny warranty solely for the lack of receipts or for the owner's failure to ensure the performance of all scheduled maintenance. However, as the off-road diesel engine owner, you should be aware that John Deere may deny you warranty coverage if your off-road diesel engine or a part has failed due to abuse, neglect, improper maintenance or unapproved modifications.

The off-road diesel engine is designed to operate on diesel fuel as specified in the Fuels, Lubricants and Coolants section in the Operators Manual. Use of any other fuel may result in the engine no longer operating in compliance with applicable emissions requirements.

The owner is responsible for initiating the warranty process, and should present the machine to the nearest authorized John Deere dealer as soon as a problem is suspected. The warranty repairs should be completed by the authorized John Deere dealer as quickly as possible.

Emissions regulations require the customer to bring the unit to an authorized servicing dealer when warranty service is required. As a result, John Deere is NOT liable for travel or mileage on emissions warranty service calls.

Emission\_CI\_CARB (14Apr20)

DX,EMISSIONS,CARB -19-26AUG20-8/8

RG32759—UN—19AUG20

## FCC Notifications to User

### FCC Notification

These devices comply with Part 15 of the FCC Rules. Operation is subject to the following two conditions: (1) These devices may not cause harmful interference, and (2) these devices must accept any interference received, including interference that may cause undesired operation.

These devices must be operated as supplied by John Deere Ag Management Solutions. Any changes or modifications made to these devices without the express written approval of John Deere Ag Management Solutions may void the user's authority to operate these devices.

### Modular Telematics Gateway and Satellite Module

This equipment has been tested and found to comply with the limits for Class B digital devices, pursuant to part 15 of the FCC Rules. These limits are designed to provide reasonable protection against harmful interference in a

residential installation. This equipment generates, uses, and can radiate radio frequency energy, and if not installed and used in accordance with the instructions, may cause harmful interference to radio communications. However, no guarantee shall be made that interference will not occur in a particular installation. If this equipment does cause harmful interference to radio or television reception, which can be determined by turning the equipment off and on, the user is encouraged to try to correct the interference by one or more of the following measures:

- Reorient or relocate the receiving antenna.
- Increase the separation between the equipment and receiver.
- Connect the equipment into an outlet on a circuit different from that to which the receiver is connected.
- Consult the dealer or an experienced radio/TV technician for help.

MM16284,000196F -19-20FEB19-1/1

## Service ADVISOR™ Remote (SAR)—SOFTWARE TERMS AND CONDITIONS

IMPORTANT -- READ CAREFULLY: THIS SOFTWARE LICENSE AGREEMENT IS A LEGAL CONTRACT BETWEEN YOU AND THE LICENSOR ("LICENSOR") IDENTIFIED BELOW AND GOVERNS YOUR USE OF THE SOFTWARE DELIVERED TO YOUR MACHINE (THE "MACHINE").

BY INDICATING YOUR ACCEPTANCE ON A DISPLAY ON THE MACHINE, BY INSTALLING SOFTWARE TO THE MACHINE, OR USING SOFTWARE ON THE MACHINE, YOU ARE ACCEPTING AND AGREEING TO THE TERMS OF THIS LICENSE AGREEMENT WITH RESPECT TO THE SOFTWARE (THE "Software") THAT IS DELIVERED TO YOUR MACHINE. YOU AGREE THAT THIS SOFTWARE LICENSE AGREEMENT, INCLUDING THE WARRANTY DISCLAIMERS, LIMITATIONS OF LIABILITY AND TERMINATION PROVISIONS BELOW, IS BINDING UPON YOU, AND UPON ANY COMPANY ON WHOSE BEHALF YOU USE THE SOFTWARE AS WELL AS THE EMPLOYEES OF ANY SUCH COMPANY (COLLECTIVELY REFERRED TO AS "YOU" IN THIS SOFTWARE LICENSE AGREEMENT). IF YOU DO NOT AGREE TO THE TERMS OF THIS AGREEMENT, OR IF YOU ARE NOT AUTHORIZED TO ACCEPT THESE TERMS ON BEHALF OF YOUR COMPANY OR ITS EMPLOYEES, PLEASE CLICK THE [Decline] ICON ON THE DISPLAY ON THE MACHINE TO DECLINE THESE TERMS AND CONDITIONS. THIS LICENSE AGREEMENT REPRESENTS THE ENTIRE AGREEMENT CONCERNING THE SOFTWARE BETWEEN YOU AND THE LICENSOR.

**1. Delivery of Software.** Software may be delivered to your Machine by Licensor wirelessly or via an agent of Licensor, such as a dealer. If it is delivered wirelessly, you may be responsible for any data transmission fees incurred due to such delivery.

**2. License.** Licensor hereby grants to you, and you accept, a nonexclusive license to use the Software in machine-readable, object code form, only as authorized in this License Agreement and the applicable provisions of the Operators' Manuals, which you agree to review carefully prior to using the Software. The Software may be used only on the Machine to which it was initially delivered. You agree that you will not assign, sublicense, transfer, pledge, lease, rent, or share your rights under this License Agreement, except that you may permanently transfer all of your rights under this License Agreement in connection with the sale of the Machine on which the Software covered by this Agreement is installed.

**3. Licensor's Rights.** You acknowledge and agree that the Software is proprietary to Licensor and is protected under copyright law. You further acknowledge and agree that all right, title, and interests in and to the Software, including associated intellectual property rights, are and shall remain with Licensor. This License Agreement does not convey to you any title or interest in or to the Software, but only a limited right of use revocable in accordance with the terms of this License Agreement. You agree

that you will not: (a) reverse assemble, reverse compile, modify, or otherwise translate the Software, or attempt to defeat the copyright protection and application enabling mechanisms therein; (b) copy or reproduce the Software; or, (b) remove or obliterate any copyright, trademark or other proprietary rights notices from the Software. You also agree not to permit any third party acting under your control to do any of the foregoing.

**4. License Fees.** The license fees paid by you, if any, are paid in consideration of the licenses granted under this License Agreement.

**5. Limited Warranty.** Licensor warrants, for your benefit alone and not for the benefit of any other party, that during the "**Warranty Period**" defined below, the Software will operate substantially in accordance with the applicable functional specifications ("**Specifications**") set forth in the Operators' Manuals. If, prior to expiration of the Warranty Period, the Software fails to perform substantially in accordance with the Specifications, you may return the Machine to the place of purchase for repair or replacement of the non-performing Software. The Warranty Period is ninety (90) days from the date of installation of the Software or the duration of the warranty period of the component of the Machine on which the Software is installed, whichever is longer. The Software Warranty Period does not affect the warranty period of the Machine itself or any component thereof.

**6. DISCLAIMER OF WARRANTIES.** YOU HEREBY AGREE THAT THE LIMITED WARRANTY PROVIDED ABOVE (THE "**LIMITED WARRANTY**") CONSTITUTES YOUR SOLE AND EXCLUSIVE REMEDY FOR ANY PROBLEM WHATSOEVER WITH THE SOFTWARE. EXCEPT AS PROVIDED IN THE LIMITED WARRANTY, THE SOFTWARE IS LICENSED "AS IS," AND LICENSOR, ITS AFFILIATES AND THIRD PARTY SUPPLIERS EXPRESSLY DISCLAIM AND YOU EXPRESSLY WAIVE, RELEASE AND RENOUNCE ALL WARRANTIES ARISING BY LAW OR OTHERWISE WITH RESPECT TO THE SOFTWARE, INCLUDING, BUT NOT LIMITED TO: ANY IMPLIED WARRANTY OF MERCHANTABILITY OR FITNESS FOR A PARTICULAR PURPOSE; ANY IMPLIED WARRANTY ARISING FROM COURSE OF PERFORMANCE, COURSE OF DEALING OR TRADE USAGE; ANY WARRANTY OF TITLE OR NON-INFRINGEMENT; AND, ANY OTHER WARRANTY ARISING UNDER ANY THEORY OF LAW, INCLUDING TORT, NEGLIGENCE, STRICT LIABILITY, CONTRACT OR OTHER LEGAL OR EQUITABLE THEORY. NO REPRESENTATION OR OTHER AFFIRMATION OF FACT INCLUDING, BUT NOT LIMITED TO, STATEMENTS REGARDING SUITABILITY FOR USE, SHALL BE DEEMED TO BE A WARRANTY BY LICENSOR OR ANY OF ITS AFFILIATES OR THIRD PARTY SUPPLIERS. LICENSOR DOES NOT WARRANT THAT THE SOFTWARE IS ERROR-FREE OR WILL OPERATE WITHOUT INTERRUPTION.

Continued on next page

OUT4001,00006C5 -19-08NOV10-1/4

**7. LIMITATION OF LIABILITY.** EXCEPT AS SET FORTH IN THE LIMITED WARRANTY, UNDER NO CIRCUMSTANCES SHALL LICENSOR, ITS AFFILIATES OR ITS THIRD PARTY SUPPLIERS BE LIABLE TO YOU OR TO ANY THIRD PARTIES FOR DIRECT, INDIRECT, INCIDENTAL OR CONSEQUENTIAL DAMAGES OF ANY KIND, INCLUDING ANY LOSS OR DAMAGE CAUSED BY THE SOFTWARE; ANY PARTIAL OR TOTAL FAILURE OF THE SOFTWARE; PERFORMANCE, NONPERFORMANCE OR DELAYS IN CONNECTION WITH ANY INSTALLATION, MAINTENANCE, WARRANTY OR REPAIRS OF THE SOFTWARE, DAMAGES FOR CROP LOSS, DAMAGE TO LAND, LOST PROFITS, LOSS OF BUSINESS OR LOSS OF GOODWILL, LOSS OF USE OF EQUIPMENT OR SERVICES OR DAMAGES TO BUSINESS OR REPUTATION ARISING FROM THE PERFORMANCE OR NON-PERFORMANCE OF ANY ASPECT OF THIS AGREEMENT, WHETHER IN CONTRACT, TORT OR OTHERWISE, AND WHETHER OR NOT LICENSOR, ITS AFFILIATES OR ITS THIRD PARTY SUPPLIERS HAVE BEEN ADVISED OF THE POSSIBILITY OF SUCH DAMAGES. IN NO EVENT SHALL LICENSOR'S CUMULATIVE LIABILITY TO YOU OR TO ANY OTHER PARTY FOR ANY LOSSES OR DAMAGES RESULTING FROM ANY CLAIMS, LAWSUITS, DEMANDS, OR ACTIONS ARISING FROM OR RELATING TO USE OF THE SOFTWARE EXCEED YOUR TOTAL PAYMENT FOR THE MACHINE AND FOR THE LICENSE OF THE SOFTWARE.

**8. Termination of License.** Licensor may terminate the license granted under this Agreement upon written notice of termination provided to you if you violate any material term of this Agreement pertaining to your use of the Software or Licensor's rights, including, without limitation, the provisions of Sections 2 and 3 above.

**9. Compliance with Law.** You agree that you will use the Software in accordance with United States law and the laws of the country in which you are located, as applicable, including foreign trade control laws and regulations. The Software may be subject to export and other foreign trade controls restricting re-sales and/or transfers to other countries and parties. By accepting the terms of this Agreement, you acknowledge that you understand that the Software may be so controlled, including, but not limited to, by the Export Administration Regulations and/or the foreign trade control regulations of the Treasury Department of the United States. Any other provision of this Agreement to the contrary notwithstanding, you agree that the Software will not be resold, re-exported or otherwise transferred. The Software remains subject to applicable U.S. laws.

**10. Indemnification.** You agree to defend, indemnify and hold Licensor, its affiliates and third party supplier, and their, officers, directors, employees, agents and representatives (each an "**Indemnified Party**"), harmless

from and against all claims, demands proceedings, injuries, liabilities, losses, or costs and expenses (including reasonable legal fees) brought by any third party against any such persons arising from or in connection with your use of the Software, regardless of whether such losses are caused, wholly or partially, by any negligence, breach of contract or other fault of an Indemnified Party.

**11. Costs of Litigation.** If any claim or action is brought by either party to this License Agreement against the other party regarding the subject matter hereof, the prevailing party shall be entitled to recover, in addition to any other relief granted, reasonable attorney fees and expenses of litigation.

**12. Severability and Waiver.** Should any term of this Agreement be declared void or unenforceable by any court of competent jurisdiction, such declaration shall have no effect on the remaining terms hereof. The failure of either party to enforce any rights granted hereunder or to take action against the other party in the event of any breach hereunder shall not be deemed a waiver by that party as to subsequent enforcement of rights of subsequent actions in the event of future breaches.

**13. Language Clause.** If you are a resident of Canada at the time you accept this Agreement, then the parties hereby acknowledge that they have required this Agreement, and all other documents relating hereto, be drawn up in the English language only. Les parties reconnaissent avoir demandé que le présent contrat ainsi que toute autre entente ou avis requis ou permis à être conclu ou donné en vertu des stipulations du présent contrat, soient rédigés en langue anglaise seulement. If you are a resident of any country other than the United States, Canada, Great Britain, Australia or New Zealand then you agree as follows: there may be a translated version of this Agreement. If there is an inconsistency or contradiction between the translated version and the English version of this Agreement, the English version of this Agreement shall control.

**14. Assignment by Licensor.** Licensor may assign this Agreement without your prior consent to any company or entity affiliated with Licensor, or by an assignment associated with a corporate restructuring, merger or acquisition.

**15. Governing Law and Forum.** This Agreement will be governed by and construed in accordance with the substantive laws identified in the table in Section 18, below. The respective courts of the venue identified in the table in Section 18, below, for the location of the Machine shall have non-exclusive jurisdiction over all disputes relating to this Agreement. This Agreement will not be governed by the conflict of law rules of any jurisdiction or the United Nations Convention on Contracts for the International Sale of Goods, the application of which is expressly excluded.

**16. Specific Exceptions.**

**16.1 Limited Warranty for Users Residing in European Economic Area Countries or Switzerland.** If you obtained the Software in any European Economic Area country or Switzerland, and you usually reside in such country, then Section 6 does not apply, instead, Licensor warrants that the Software provides the functionalities set forth in the Operators Manuals (the "**agreed upon functionalities**") for the Warranty Period. As used in this Section, "Warranty Period" means one (1) year. Non-substantial variation from the agreed upon functionalities shall not be considered and does not establish any warranty rights. THIS LIMITED WARRANTY DOES NOT APPLY TO SOFTWARE PROVIDED TO YOU FREE OF CHARGE, FOR EXAMPLE, UPDATES, OR SOFTWARE THAT HAS BEEN ALTERED BY YOU, TO THE EXTENT SUCH ALTERATIONS CAUSED A DEFECT. To make a warranty claim, during the Warranty Period you must return, at our expense, the Software and proof of purchase to the location where you obtained it. If the functionalities of the Software vary substantially from the agreed upon functionalities, Licensor is entitled -- by way of re-performance and at its own discretion -- to repair or replace the Software. If this fails, you are entitled to a reduction of the purchase price (reduction) or to cancel the purchase agreement (rescission). For further warranty information, please contact Licensor at the address listed in Section 18.

**16.2 Limitation of Liability for Users Residing in European Economic Area Countries or Switzerland.**

(a) If you obtained the Software in any European Economic Area country or Switzerland, and you usually reside in such country, then Sections 7 and 10 do not apply. Instead, Licensor's statutory liability for damages shall be limited as follows: (a) Licensor shall be liable only up to the amount of damages as typically foreseeable at the time of entering into this Agreement in respect of damages caused by a slightly negligent breach of a material contractual obligation and (b) Licensor shall

not be liable for damages caused by a slightly negligent breach of a non-material contractual obligation.

(b) The aforesaid limitation of liability shall not apply to any mandatory statutory liability, in particular, to liability under the German Product Liability Act, liability for assuming a specific guarantee or liability for culpably caused personal injuries.

(c) You are required to take all reasonable measures to avoid and reduce damages, in particular to make back-up copies of the Software and your computer data subject to the provisions of this Agreement.

**17. Representations of Licensee.** BY ACCEPTING THIS AGREEMENT, YOU: (A) ACKNOWLEDGE THAT YOU HAVE READ AND UNDERSTAND THIS AGREEMENT; (B) REPRESENT THAT YOU HAVE THE AUTHORITY TO ENTER INTO THIS AGREEMENT; (C) AGREE THAT THIS AGREEMENT IS ENFORCEABLE AGAINST YOU AND ANY LEGAL ENTITY THAT OBTAINED THE SOFTWARE AND ON WHOSE BEHALF IT IS USED; AND, (D) AGREE TO PERFORM THE OBLIGATIONS OF THIS AGREEMENT.

**18. Identification of Licensor and Notices.** The Licensor is the entity identified in the table below. All notices to Licensor shall be sent by certified or registered mail to the corresponding address for the Licensor given below. In each case a copy of the notice shall also be sent to John Deere Intelligent Solutions Group, ATTN: Legal, 4140 114th Street Urbandale, IA 50322 U.S.A. All notices to Licensor shall be effective upon receipt. All notices required to be given to you shall, in Licensor's sole discretion, either be sent via certified or registered mail to the address given to Licensor in connection with your purchase of the Machine. Either method of notification used by Licensor shall be effective upon dispatch. You agree to notify Licensor of any change in your address in the manner set forth above.

Place of Purchase	Address	Governing Law	Venue
United States of America	John Deere Shared Services, Inc. One John Deere Place Moline, IL 61265 U.S.A.	State of Illinois, USA	Rock Island County, Illinois, USA
Argentina	Industrias John Deere Argentina, S.A. Casilla de Correo 80 Rosario (Santa Fe), 2000, Argentina	Province of Santa Fe, Argentina	Province of Santa Fe, Argentina
Australia or New Zealand	John Deere Limited (Australia) P.O. Box 2022 Crestmead, Queensland, Australia 4132	State of Queensland, Australia	State of Queensland, Australia
Canada	John Deere Limited 295 Hunter Road P.O. Box 1000 Grimsby, ON L9K 1M3	Province of Ontario, Canada	Province of Ontario, Canada
Chile	John Deere Water, S.A. Cerro Santa Lucia 9990 Quilicura, Santiago, Chile	Province of Santiago, Chile	Province of Santiago, Chile
Mexico	Industrias John Deere, S.A. de C.V. Boulevard Diaz Ordaz #500 Garza Garcia Nuevo Leon 66210, Mexico	State of Nuevo Leon, Mexico	State of Nuevo Leon, Mexico

Continued on next page

OUT4001.00006C5 -19-08NOV10-3/4

## Introduction

Europe	ETIC Strassburgerallee 5 67657 Kaiserslautern, Germany	Federal Republic of Germany	Kaiserslautern, Germany
Other	The John Deere entity identified for the location of your Machine on <a href="http://www.JDLink.com">www.JDLink.com</a> .	The John Deere entity identified for the location of your Machine on <a href="http://www.JDLink.com">www.JDLink.com</a> .	The John Deere entity identified for the location of your Machine on <a href="http://www.JDLink.com">www.JDLink.com</a> .

OUT4001.00006C5 -19-08NOV10-4/4

### John Deere Online Bookstore

The Technical Service Information Bookstore is available for John Deere Construction & Forestry, Hitachi, and Waratah products.

Technical information can be purchased from John Deere. Publications are available in print, PDF download, or PDF on DVD formats.

Orders can be made using one of the following:

- John Deere Technical Information Store:  
<http://www.johndeeretechno.com/>
- Call 1-866-213-3373
- Contact an authorized John Deere dealer

Available information includes:

- PARTS CATALOGS listing service parts available for machines with exploded view illustrations to help identify the correct parts. It is also useful in assembling and disassembling.
- OPERATOR'S MANUALS providing safety, operating, maintenance, and service information.
- TECHNICAL MANUALS outlining service information for machines. Included are specifications, illustrated assembly and disassembly procedures, hydraulic oil flow diagrams, and wiring diagrams. Some products have separate manuals for repair and diagnostic information. Some components, such as engines, are available in a separate component technical manual.



*John Deere Online Bookstore*

- TRAINING GUIDES AND VIDEOS covering components, preventative maintenance, operation safety, and demonstration tips.

TX1213033 —UN—07APR16

MB60223.0005117 -19-17MAR17-1/1

**Technical Information Feedback Form**

We need your help to continually improve our technical publications. Please copy this page and FAX or mail your comments, ideas and improvements.

**SEND TO:** John Deere Dubuque Works  
18600 South John Deere Road  
Attn: Publications, Dept. 324  
Dubuque, IA 52004-0538  
USA

**FAX NUMBER:** 1-563-589-5800 (USA)

Publication Number: \_\_\_\_\_

Page Number: \_\_\_\_\_

Ideas, Comments: \_\_\_\_\_  
\_\_\_\_\_  
\_\_\_\_\_  
\_\_\_\_\_  
\_\_\_\_\_  
\_\_\_\_\_  
\_\_\_\_\_  
\_\_\_\_\_  
\_\_\_\_\_  
\_\_\_\_\_  
\_\_\_\_\_  
\_\_\_\_\_  
\_\_\_\_\_

Name: \_\_\_\_\_

Phone: \_\_\_\_\_

Email Address: \_\_\_\_\_

**THANK YOU!**



# Contents

Page	Page
<b>Safety—Safety and Operator Conveniences</b>	
Safety and Operator Convenience Features ..... 1-1-1	
<b>Safety—General Precautions</b>	
Recognize Safety Information ..... 1-2-1	
Follow Safety Instructions ..... 1-2-1	
Operate Only If Qualified ..... 1-2-1	
Wear Protective Equipment ..... 1-2-2	
Avoid Unauthorized Machine Modifications ..... 1-2-2	
Control Pattern Selector—If Equipped ..... 1-2-2	
Add Cab Guarding for Special Uses ..... 1-2-2	
Inspect Machine ..... 1-2-3	
Stay Clear of Moving Parts ..... 1-2-3	
Avoid High-Pressure Fluids ..... 1-2-3	
Avoid High-Pressure Oils ..... 1-2-4	
Work In Ventilated Area ..... 1-2-4	
Avoid Static Electricity Risk When Refueling ..... 1-2-5	
Prevent Fires ..... 1-2-6	
In Case of Machine Fire ..... 1-2-6	
Prevent Battery Explosions ..... 1-2-7	
Handle Chemical Products Safely ..... 1-2-7	
Handle Starting Fluid Safely ..... 1-2-7	
Decommissioning — Proper Recycling and Disposal of Fluids and Components ..... 1-2-8	
Exhaust Filter Ash Handling and Disposal ..... 1-2-8	
Prepare for Emergencies ..... 1-2-8	
Clean Debris from Machine ..... 1-2-9	
<b>Safety—Operating Precautions</b>	
Use Steps and Handholds Correctly ..... 1-3-1	
Start Only From Operator's Seat ..... 1-3-1	
Use and Maintain Seat Belt ..... 1-3-1	
Prevent Unintended Machine Movement ..... 1-3-2	
Avoid Work Site Hazards ..... 1-3-2	
Keep Riders Off Machine ..... 1-3-3	
Avoid Backover Accidents ..... 1-3-3	
Inspect and Maintain ROPS ..... 1-3-3	
Avoid Machine Tip Over and Machine Damage ..... 1-3-4	
Use Special Care When Lifting Objects ..... 1-3-4	
Travel Safely ..... 1-3-5	
Prevent Acid Burns ..... 1-3-5	
Add and Operate Attachments Safely ..... 1-3-5	
<b>Safety—Maintenance Precautions</b>	
Park and Prepare for Service Safely ..... 1-4-1	
Service Cooling System Safely ..... 1-4-1	
Remove Paint Before Welding or Heating ..... 1-4-2	
Make Welding Repairs Safely ..... 1-4-2	
Drive Metal Pins Safely ..... 1-4-2	
Clean Exhaust Filter Safely ..... 1-4-3	
<b>Safety—Safety Signs</b>	
Safety Signs and Other Instructions ..... 1-5-1	
Safety Signs Installed on Hydraulic Coupler—If Equipped ..... 1-5-14	
<b>Operation—Operator's Station</b>	
Pedals, Levers, and Panels ..... 2-1-1	
Switch Panel ..... 2-1-2	
Switch Panel Functions ..... 2-1-3	
Rear Left Panel ..... 2-1-4	
Horn ..... 2-1-4	
Power Boost Button ..... 2-1-4	
Pilot Shutoff Lever ..... 2-1-5	
Left Console ..... 2-1-5	
Travel Alarm and Travel Alarm Cancel Switch ..... 2-1-5	
Seat Heater Switch—If Equipped ..... 2-1-6	
Reversing Fan Switch—If Equipped ..... 2-1-6	
Right Console ..... 2-1-6	
Exhaust Filter Parked Cleaning Switch—6090HT010 Engine Only ..... 2-1-7	
Right Enable Switch ..... 2-1-7	
Service ADVISOR™ Remote (SAR) Switch ..... 2-1-8	
Auxiliary Function Enable Switch—If Equipped ..... 2-1-8	
Cab Heater and Air Conditioner ..... 2-1-9	
Selecting Display Between Celsius and Fahrenheit ..... 2-1-10	
Operating the AM/FM Radio ..... 2-1-11	
Fire Extinguisher Mounting Location ..... 2-1-12	
Alternative Exit Tool ..... 2-1-12	
Cab Dome Light Switch ..... 2-1-13	
Opening Upper Front (Alternative Exit) Window ..... 2-1-13	
Removing and Storing the Lower Front Window ..... 2-1-14	
Opening Cab Door Window ..... 2-1-14	
Opening and Closing the Polycarbonate-Type Roof Exit Cover ..... 2-1-15	
Adjusting the Mechanical Suspension Seat ..... 2-1-15	

Continued on next page

*Original Instructions. All information, illustrations and specifications in this manual are based on the latest information available at the time of publication. The right is reserved to make changes at any time without notice.*

COPYRIGHT © 2021  
DEERE & COMPANY  
Moline, Illinois  
All rights reserved.  
A John Deere ILLUSTRATION™ Manual  
Previous Editions  
Copyright © 2011, 2012, 2013, 2014, 2015, 2016, 2017, 2019

Page	Page		
Adjusting the Air Suspension Seat—If Equipped .....	2-1-16	Service ADVISOR™ Remote (SAR) Operation .....	2-3-12
Adjusting Pilot Control Lever Console Height .....	2-1-16	Locking the Hydraulic Coupler to the Attachment—If Equipped .....	2-3-14
<b>Operation—Monitor Operation</b>		Unlocking the Hydraulic Coupler From the Attachment—If Equipped .....	2-3-16
Monitor .....	2-2-1	Control Lever Pattern Operation .....	2-3-17
Monitor Functions .....	2-2-2	Control Lever Pattern Conversion .....	2-3-18
Monitor Start-Up .....	2-2-3	Mechanical Control Lever Pattern Selector—If Equipped .....	2-3-19
Main Menu .....	2-2-4	Operating in Water and Mud .....	2-3-19
Main Menu—Alarm List .....	2-2-5	Driving Up a Steep or Slippery Slope .....	2-3-20
Main Menu—Air Conditioner .....	2-2-11	Required Machine Stop Warning .....	2-3-20
Main Menu—Radio .....	2-2-13	Lifting .....	2-3-22
Main Menu—Work Mode .....	2-2-14	Lower Boom With Engine Stopped .....	2-3-23
Main Menu—Setting Menu .....	2-2-15	Parking the Machine .....	2-3-24
Main Menu—Setting Menu—Date and Time .....	2-2-16	Loading and Unloading for Transport .....	2-3-25
Main Menu—Setting Menu—Attachment Name Input .....	2-2-16	Towing Machine .....	2-3-26
Main Menu—Setting Menu—Auto-Shutdown .....	2-2-17	Lifting the Machine .....	2-3-26
Main Menu—Setting Menu—Auto Exhaust Filter Cleaning .....	2-2-18	<b>Maintenance—Machine</b>	
Main Menu—Setting Menu—Sub Meter Selection .....	2-2-19	Diesel Fuel .....	3-1-1
Main Menu—Setting Menu—Rear View Camera Monitor .....	2-2-20	Diesel Fuel Specifications .....	3-1-1
Main Menu—Setting Menu—Display Item Selection .....	2-2-21	Lubricity of Diesel Fuel .....	3-1-2
Main Menu—Setting Menu—Brightness Adjustment .....	2-2-21	Handling and Storing Diesel Fuel .....	3-1-2
Main Menu—Setting Menu—Language .....	2-2-21	Biodiesel Fuel .....	3-1-3
Main Menu—Setting Menu—Unit Selection .....	2-2-22	Testing Diesel Fuel .....	3-1-4
Main Menu—Setting Menu—Main Menu Sequence Change .....	2-2-22	Supplemental Diesel Fuel Additives .....	3-1-4
Main Menu—Information Menu .....	2-2-23	Fuel Filters .....	3-1-4
Main Menu—Information Menu—Operation .....	2-2-24	Minimizing the Effect of Cold Weather on Diesel Engines .....	3-1-5
Main Menu—Information Menu—Maintenance .....	2-2-25	Alternative and Synthetic Lubricants .....	3-1-6
Main Menu—Information Menu—Troubleshooting .....	2-2-25	Mixing of Lubricants .....	3-1-6
Main Menu—Information Menu—Monitoring .....	2-2-26	Lubricant Storage .....	3-1-6
<b>Operation—Operating the Machine</b>		Diesel Engine Break-In™ Oil—Non-Emissions Certified and Certified Tier 1, Tier 2, Tier 3, Stage I, Stage II, and Stage III .....	3-1-7
Before Starting Work .....	2-3-1	John Deere Break-In Plus™ Engine Oil — Interim Tier 4, Final Tier 4, Stage IIIB, Stage IV, and Stage V .....	3-1-7
Operator's Daily Machine Check		Diesel Engine Oil — Tier 2 and Stage II .....	3-1-8
Before Starting .....	2-3-1	Engine Oil and Filter Service Intervals — Tier 2 and Stage II Engines .....	3-1-9
Engine Break-In Period .....	2-3-2	Diesel Engine Oil — Tier 3 and Stage IIIA .....	3-1-10
Starting Engine .....	2-3-3	Engine Oil and Filter Service Intervals—Tier 3 and Stage IIIA Engines .....	3-1-11
Cold Weather Start Aid—If Equipped .....	2-3-4	Diesel Engine Oil — Interim Tier 4, Final Tier 4, Stage IIIB, Stage IV, and Stage V .....	3-1-12
Cold Weather Warm-Up .....	2-3-5	Engine Oil and Filter Service Intervals — Interim Tier 4, Final Tier 4, Stage IIIB, Stage IV, and Stage V Engines .....	3-1-13
Operate Within Machine Limits .....	2-3-6	Diesel Engine Oil Service Interval for Operation at High Altitude .....	3-1-13
Travel Pedals and Levers .....	2-3-6	Oil Filters .....	3-1-14
Auxiliary Function Lever (AFL) .....	2-3-7	Hydraulic Oil .....	3-1-15
Exhaust Filter—6090HT010 Engine Only .....	2-3-8		
Exhaust Filter Parked Cleaning—6090HT010 Engine Only .....	2-3-10		
Service ADVISOR™ Remote (SAR) Software Delivery Process .....	2-3-11		

Continued on next page

Page	Page
Swing Gear Case and Travel Gear	
Case Oils.....	3-1-16
Pump Drive Gear Case Oil.....	3-1-16
Track Adjuster, Working Tool Pivot, Swing Bearing, and Swing Bearing	
Gear Grease .....	3-1-17
Diesel Engine Coolant (engine with wet sleeve cylinder liners).....	3-1-18
Water Quality for Mixing with Coolant Concentrate.....	3-1-19
Operating in Warm Temperature Climates .....	3-1-19
Testing Coolant Freeze Point .....	3-1-20
Disposing of Coolant .....	3-1-20
<b>Maintenance—Periodic Maintenance</b>	
Service Machine at Specified Intervals.....	3-2-1
Check the Hour Meter Regularly .....	3-2-1
Engine Identification .....	3-2-1
Prepare Machine for Maintenance .....	3-2-4
Open Access Doors for Service .....	3-2-5
Open Engine Cover for Service.....	3-2-5
Fuel Tank.....	3-2-6
Hydraulic Breaker Attachment.....	3-2-6
Fluid Analysis Program Test Kits and 3-Way Coolant Test Kit.....	3-2-6
Service Intervals—6090HT010 Engine Only.....	3-2-7
Required Parts—6090HT010 Engine Only.....	3-2-9
Service Intervals—6090HT002 and 6090HT006 Engines Only.....	3-2-10
Required Parts—6090HT002 and 6090HT006 Engines Only.....	3-2-12
<b>Maintenance—As Required</b>	
Remove and Clean Fuel Tank Inlet Screen.....	3-3-1
Check Windshield Washer Fluid Level.....	3-3-1
Check and Clean Air Cleaner Dust Unloader Valve.....	3-3-1
Check and Adjust Track Sag.....	3-3-2
Clean Rear Camera Lens—If Equipped.....	3-3-3
Service Exhaust Filter—6090HT010 Engine Only.....	3-3-3
Clean and Tighten Battery Terminals .....	3-3-4
<b>Maintenance—Every 10 Hours or Daily</b>	
Check Engine Oil Level.....	3-4-1
Check Engine Coolant Level.....	3-4-2
Check Hydraulic Tank Oil Level.....	3-4-3
Lubricate Hydraulic Coupler—If Equipped .....	3-4-4
<b>Maintenance—Every 50 Hours or Weekly</b>	
Drain Water and Sediment from Fuel Tank Sump .....	3-5-1
Drain Primary Fuel Filter and Water Separator .....	3-5-2
Drain Final Fuel Filter—6090HT002 and 6090HT006 Engines Only.....	3-5-2
Drain Auxiliary Fuel Filter and Water Separator—If Equipped.....	3-5-3
Lubricate Working Tool Pivots .....	3-5-4
<b>Maintenance—Every 100 Hours</b>	
Inspect and Re-Torque Track Hardware.....	3-6-1
<b>Maintenance—Every 250 Hours</b>	
Check Swing Gear Case Oil Level .....	3-7-1
Drain Water and Sediment From Hydraulic Tank.....	3-7-2
Check Pump Drive Gear Case Oil Level .....	3-7-3
Check and Adjust Air Conditioner Belt—6090HT002 and 6090HT006 Engines Only.....	3-7-3
Check Hybrid Battery Electrolyte Level—If Equipped.....	3-7-4
Check Travel Gear Case Oil Level .....	3-7-6
Lubricate Front End Pin Joints .....	3-7-7
Take Engine Oil Sample .....	3-7-7
<b>Maintenance—Every 500 Hours</b>	
Lubricate Swing Bearing.....	3-8-1
Lubricate Swing Bearing Gear.....	3-8-1
Replace Primary Fuel Filter and Water Separator—6090HT010 Engine Only .....	3-8-2
Replace Primary Fuel Filter and Water Separator—6090HT002 and 6090HT006 Engines Only .....	3-8-3
Replace Final Fuel Filter.....	3-8-4
Replace Auxiliary Fuel Filter and Water Separator—If Equipped.....	3-8-5
Check Air Intake Hoses .....	3-8-6
Drain and Refill Engine Oil and Replace Filter .....	3-8-7
Clean Cab Fresh Air and Cab Recirculating Air Filters .....	3-8-8
Take Fluid Samples .....	3-8-8
<b>Maintenance—Every 1000 Hours</b>	
Drain and Refill Swing Gear Case Oil .....	3-9-1
Replace Hydraulic Tank Oil Filter .....	3-9-2
Replace Pilot Oil Filter.....	3-9-3
Inspect Serpentine Belt—6090HT010 Engine Only.....	3-9-4
Inspect Serpentine Belt—6090HT002 and 6090HT006 Engines Only .....	3-9-5
Drain and Refill Pump Drive Gear Case Oil .....	3-9-6
Remove and Clean Open Crankcase Ventilation (OCV) Hose—6090HT010 Engine Only.....	3-9-6
Clean the Engine Crankcase Ventilation Tube—6090HT002 and 6090HT006 Engines Only .....	3-9-7
Replace Air Cleaner Elements .....	3-9-8
Replace Air Cleaner Dust Unloader Valve.....	3-9-8
Check Coolant Condition.....	3-9-9

Continued on next page

Page	Page
	Metric Bolt and Screw Torque Values.....4-1-21
<b>Maintenance—Every 2000 Hours</b>	<b>Miscellaneous—Operational Checkout</b>
Check and Adjust Engine Valve Lash.....3-10-1	Operational Checkout.....4-2-1
Drain and Refill Travel Gear Case Oil .....3-10-1	
<b>Maintenance—Every 4000 Hours</b>	<b>Miscellaneous—Troubleshooting</b>
Replace Engine Crankshaft	Troubleshooting Procedure .....4-3-1
Damper—6090HT002 and	Engine .....4-3-2
6090HT006 Engines Only .....3-11-1	Hydraulic System.....4-3-5
	Electrical System.....4-3-7
	Software Update.....4-3-9
<b>Maintenance—Every 5000 Hours</b>	<b>Miscellaneous—Storage</b>
Drain and Refill Hydraulic Tank Oil.....3-12-1	Prepare Machine for Storage .....4-4-1
Replace Hydraulic Tank Vent Cap Filter .....3-12-3	Monthly Storage Procedure.....4-4-2
<b>Maintenance—Every 6000 Hours</b>	
Drain Cooling System—6090HT010	<b>Miscellaneous—Machine Numbers</b>
Engine Only.....3-13-1	Record Product Identification Number (PIN) .....4-5-1
Cooling System Fill and Deaeration	Record Engine Serial Num-
Procedure—6090HT010 Engine Only.....3-13-2	ber—6090HT010 Engine Only .....4-5-1
Drain Cooling System—6090HT002	Record Engine Serial Num-
and 6090HT006 Engines Only .....3-13-3	ber—6090HT002 Engine Only .....4-5-2
Cooling System Fill and Deaeration	Record Engine Serial Num-
Procedure—6090HT002 and	ber—6090HT006 Engine Only .....4-5-2
6090HT006 Engines Only .....3-13-4	Record Travel Motor Serial Numbers .....4-5-2
	Record Swing Motor Serial Number .....4-5-3
<b>Miscellaneous—Machine</b>	Record Hydraulic Coupler Serial
Bleed Fuel System .....4-1-1	Number—If Equipped.....4-5-3
Clean Radiator, Oil Cooler, Charge Air	Record Hydraulic Pump Serial Number.....4-5-4
Cooler and Fuel Cooler .....4-1-1	Keep Proof of Ownership .....4-5-4
Do Not Service or Adjust Injection	Keep Machines Secure .....4-5-4
Nozzles or High-Pressure Fuel Pump.....4-1-2	
Do Not Service Control Valves,	<b>Miscellaneous—Specifications</b>
Cylinders, Pumps, or Motors.....4-1-2	350GLC Engine Specifica-
Precautions for Alternator and Regulator .....4-1-2	tions—6090HT010 Engine Only.....4-6-1
Handling, Checking, and Servicing	350GLC Engine Specifica-
Batteries Carefully .....4-1-3	tions—6090HT002 and 6090HT006
Using Battery Charger .....4-1-4	Engines Only .....4-6-1
Using Booster Batteries—24-Volt System .....4-1-6	350GLC Drain and Refill Capacities.....4-6-2
Replacing Batteries .....4-1-6	350GLC Machine Specifications .....4-6-3
Fluid Sampling Test Ports—If Equipped .....4-1-7	350GLC Working Ranges.....4-6-5
Welding On Machine .....4-1-7	350GLC Lift Capacity—Arm: 2.10 m
Clean the Machine Regularly .....4-1-8	(6 ft. 10 in.); Bucket: 1273 kg (2806
Adding 12-Volt Accessories.....4-1-8	lb.); Shoe: 600 mm (24 in.) .....4-6-9
JDLink™ Machine Monitoring System	350GLC Lift Capacity—Arm: 2.10 m
(MMS)—If Equipped.....4-1-8	(6 ft. 10 in.); Bucket: 1273 kg (2806
Keep ROPS Installed Properly .....4-1-9	lb.); Shoe: 700 mm (28 in.) .....4-6-10
Replacing Fuses.....4-1-10	350GLC Lift Capacity—Arm: 2.10 m
Replacing Bucket Teeth.....4-1-13	(6 ft. 10 in.); Bucket: 1273 kg (2806
Replacing Bucket Tooth	lb.); Shoe: HEAVY DUTY 700 mm
Tip—Heavy-Duty Bucket.....4-1-14	(28 in.) .....4-6-11
Replacing Bucket Teeth—TK Series .....4-1-14	350GLC Lift Capacity—Arm: 2.10 m
Bucket Remove and Install.....4-1-15	(6 ft. 10 in.); Bucket: 1273 kg (2806
Track Sag General Information .....4-1-19	lb.); Shoe: 800 mm (32 in.) .....4-6-12
Check Track Shoe Hardware .....4-1-19	350GLC Lift Capacity—Arm: 2.67 m (8
Hardware Torque Specifications.....4-1-19	ft. 9 in.); Boom: 5.70 m (18 ft. 8 in.);
Unified Inch Bolt and Screw Torque Values.....4-1-20	

Continued on next page

Contents

	Page
Bucket: 1273 kg (2806 lb.); Shoe: 600 mm (24 in.)	4-6-13
350GLC Lift Capacity—Arm: 2.67 m (8 ft. 9 in.); Boom: 5.70 m (18 ft. 8 in.); Bucket: 1273 kg (2806 lb.); Shoe: 700 mm (28 in.)	4-6-14
350GLC Lift Capacity—Arm: 2.67 m (8 ft. 9 in.); Boom: 5.70 m (18 ft. 8 in.); Bucket: 1273 kg (2806 lb.); Shoe: HEAVY DUTY 700 mm (28 in.)	4-6-15
350GLC Lift Capacity—Arm: 2.67 m (8 ft. 9 in.); Boom: 5.70 m (18 ft. 8 in.); Bucket: 1273 kg (2806 lb.); Shoe: 800 mm (32 in.)	4-6-16
350GLC Lift Capacity—Arm: 2.67 m (8 ft. 9 in.); Boom: 6.40 m (21 ft. 0 in.); Bucket: 1170 kg (2580 lb.); Shoe: 600 mm (24 in.)	4-6-17
350GLC Lift Capacity—Arm: 2.67 m (8 ft. 9 in.); Boom: 6.40 m (21 ft. 0 in.); Bucket: 1170 kg (2580 lb.); Shoe: 800 mm (32 in.)	4-6-18
350GLC Lift Capacity—Arm: 2.67 m (8 ft. 9 in.); Boom: 6.40 m (21 ft. 0 in.); Bucket: 1273 kg (2806 lb.); Shoe: 600 mm (24 in.)	4-6-19
350GLC Lift Capacity—Arm: 2.67 m (8 ft. 9 in.); Boom: 6.40 m (21 ft. 0 in.); Bucket: 1273 kg (2806 lb.); Shoe: 700 mm (28 in.)	4-6-20
350GLC Lift Capacity—Arm: 2.67 m (8 ft. 9 in.); Boom: 6.40 m (21 ft. 0 in.); Bucket: 1273 kg (2806 lb.); Shoe: HEAVY DUTY 700 mm (28 in.)	4-6-21
350GLC Lift Capacity—Arm: 2.67 m (8 ft. 9 in.); Boom: 6.40 m (21 ft. 0 in.); Bucket: 1273 kg (2806 lb.); Shoe: 800 mm (32 in.)	4-6-22
350GLC Lift Capacity—Arm: 3.20 m (10 ft. 6 in.); Bucket: 1170 kg (2580 lb.); Shoe: 600 mm (24 in.)	4-6-23
350GLC Lift Capacity—Arm: 3.20 m (10 ft. 6 in.); Bucket: 1170 kg (2580 lb.); Shoe: 800 mm (32 in.)	4-6-24
350GLC Lift Capacity—Arm: 4.0 m (13 ft. 1 in.); Bucket: 1170 kg (2580 lb.); Shoe: 600 mm (24 in.)	4-6-25
350GLC Lift Capacity—Arm: 4.0 m (13 ft. 1 in.); Bucket: 1170 kg (2580 lb.); Shoe: 800 mm (32 in.)	4-6-27



This as a preview PDF file from [best-manuals.com](http://best-manuals.com)



Download full PDF manual at [best-manuals.com](http://best-manuals.com)