

**John Deere  
JD510  
Loader Backhoe**

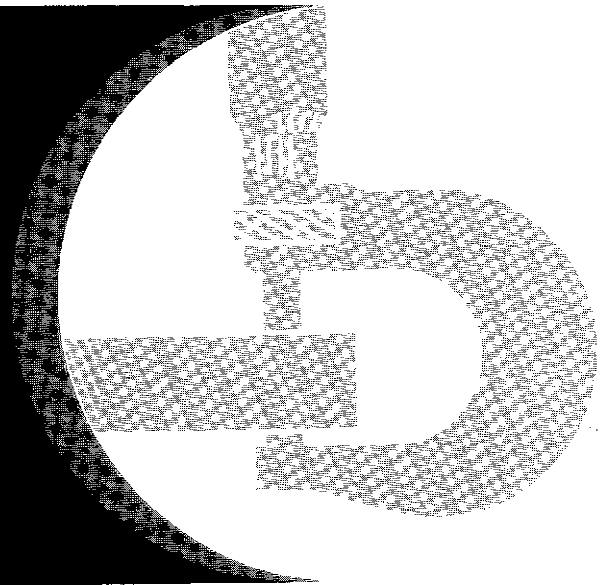

**TECHNICAL MANUAL**

**John Deere Dubuque Works**

**TM-1039**

Litho in U.S.A.



# JD510 Loader Backhoe Technical Manual TM-1039 (Oct-79)

## CONTENTS

- |  |   |
|--|---|
| <p>SECTION 10 - GENERAL</p> <ul style="list-style-type: none"> <li>Group 5 - Specifications</li> <li>Group 10 - Predelivery, Delivery, and After-Sales Services</li> <li>Group 15 - Tune-Up</li> <li>Group 20 - Lubrication</li> <li>Group 25 - Separation</li> </ul> <p>SECTION 20 - ENGINE</p> <ul style="list-style-type: none"> <li>Group 5 - Diagnosis</li> <li>Group 10 - Basic Engine</li> <li>Group 15 - Lubrication System</li> <li>Group 20 - Speed Control Linkage</li> <li>Group 25 - Cooling System</li> <li>Group 30 - Specifications and Special Tools</li> </ul> <p>SECTION 30 - FUEL SYSTEM</p> <ul style="list-style-type: none"> <li>Group 5 - Diagnosis</li> <li>Group 10 - Fuel Tank, Transfer Pump, and Filter</li> <li>Group 15 - Air Intake System</li> <li>Group 20 - Fuel Injection Pump</li> </ul> <p>SECTION 40 - ELECTRICAL SYSTEM</p> <ul style="list-style-type: none"> <li>Group 5 - General Information and Wiring Diagrams</li> <li>Group 10 - Charging System</li> <li>Group 15 - Starting Circuit</li> <li>Group 20 - Lights, Accessories, and Instruments</li> <li>Group 25 - Specifications and Special Tools</li> </ul> | <p>SECTION 50 - POWER TRAIN</p> <ul style="list-style-type: none"> <li>Group 5 - Diagnosis</li> <li>Group 10 - Clutches for Collar-Shift Transmission and PTO</li> <li>Group 15 - Collar-Shift Transmission</li> <li>Group 20 - Collar Shift PTO</li> <li>Group 25 - Engine Disconnect Clutch</li> <li>Group 30 - Power Shift Transmission</li> <li>Group 35 - Power Shift PTO</li> <li>Group 40 - Differential</li> <li>Group 45 - Final Drive</li> </ul> <p>SECTION 60 - STEERING AND BRAKES</p> <ul style="list-style-type: none"> <li>Group 5 - General Information</li> </ul> <p>SECTION 70 - HYDRAULIC SYSTEM</p> <ul style="list-style-type: none"> <li>Group 5 - General Information, Diagnosis, and Tests</li> <li>Group 6 - System Testing (Analyzer)</li> <li>Group 10 - Hydraulic Components</li> <li>Group 15 - Hydraulic Pumps</li> <li>Group 20 - Power Steering</li> <li>Group 25 - Power Brakes</li> <li>Group 30 - Loader Control Valve</li> <li>Group 35 - Backhoe Control Valve</li> <li>Group 40 - Cylinders</li> </ul> <p>SECTION 80 - MISCELLANEOUS</p> <ul style="list-style-type: none"> <li>Group 5 - Front Axle and Pivot Bracket</li> <li>Group 10 - Loader Frame, Boom, and Bucket</li> <li>Group 15 - Backhoe, Frame, Boom, and Bucket</li> </ul> |
|--|---|

## INDEX

*The specifications and design information contained in this manual were correct at the time it was printed. It is John Deere's policy to continually improve and update our machines. Therefore, the specifications and design information are subject to change without notice. Wherever applicable, specifications and design information are in accordance with SAE and IEMC standards.*

OOA

**Copyright© 1971  
DEERE & COMPANY  
Moline, Illinois  
All Rights Reserved**

## INTRODUCTION

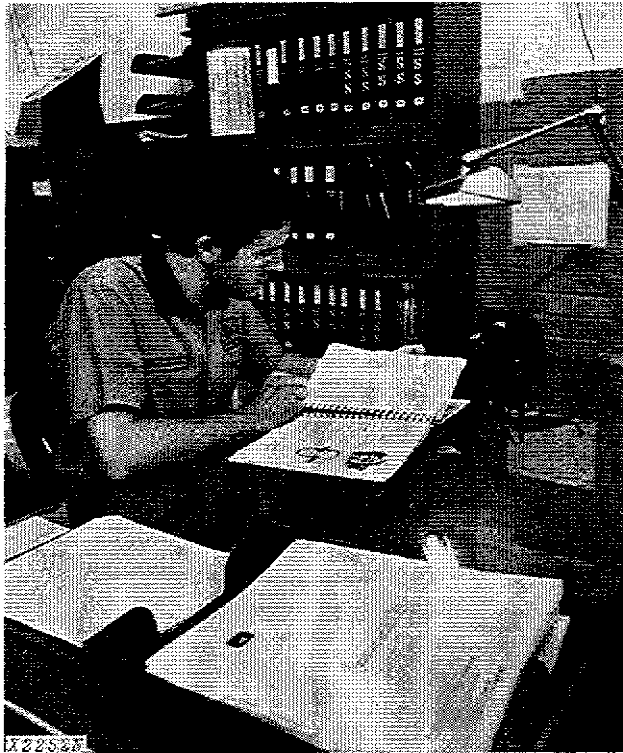

Use FOS Manuals for Reference

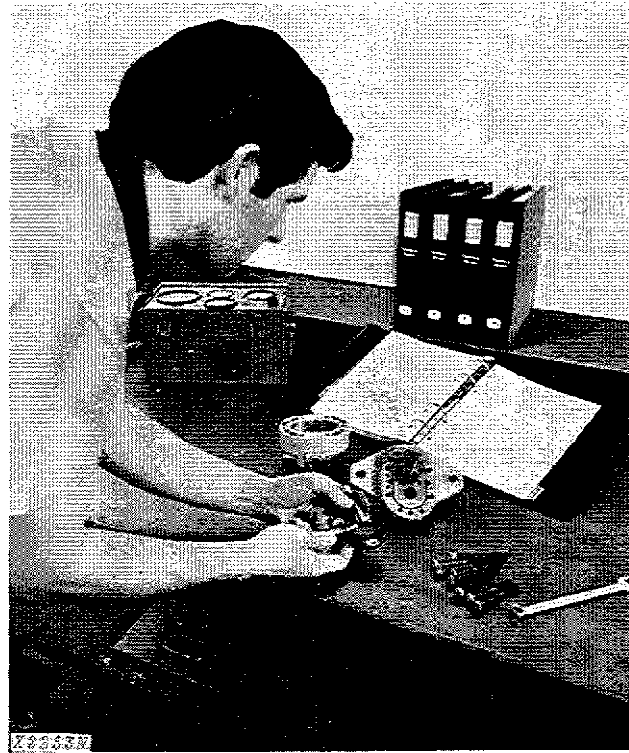

Use Technical Manuals for Actual Service

 This safety alert symbol identifies important safety messages in this manual. When you see this symbol, be alert to the possibility of personal injury and carefully read the message that follows:

This technical manual is part of a twin concept of service:

- **FOS Manuals—for reference**
- **Technical Manuals—for actual service**

The two kinds of manuals work as a team to give you both the general background and technical details of shop service.

*Fundamentals of Service (FOS) Manuals* cover basic theory of operation, *fundamentals* of trouble shooting, *general* maintenance, and *basic* types of failures and their causes. FOS Manuals are for training new service technicians and for reference by experienced service technicians.

*Technical Manuals* are concise service guides for *specific* machines. Technical Manuals are on-the-job guides containing only the vital information needed by a service technician.

Litho in U.S.A.



When a service technician should refer to a FOS Manual for more information, a FOS symbol like the one at the left is used in the technical manual to identify the reference.

Some features of this technical manual:

- *Table of contents at front of manual*
- *Exploded views showing parts relationship*
- *Photos showing service techniques*
- *Specifications grouped for easy reference*

This technical manual was planned and written for you—an experienced service technician. Keep it in a permanent binder in the shop where it is handy. Read it when you need to know correct service procedures or specifications.

**COMPLETE PAGE LISTING  
 WITH LATEST DATE LINES**

1,2	(Oct-79)	30-5-1,2	(Jan-71)
3,4	(Dec-80)	30-10-1,2	(Dec-73)
		30-10-3,4	(Nov-78)
10-5-1,2	(Oct-79)	30-15-1,2	(Nov-78)
10-5-3,4	(Oct-79)	30-20-1,2	(Nov-78)
10-10-1,2	(Nov-78)	30-20-3,4	(Nov-78)
10-10-3,4	(Nov-78)		
10-10-5,6	(Nov-78)	40-5-1,2	(Oct-79)
10-10-7,8	(Nov-78)	40-5-3,4	(May-77)
10-10-9,10	(Dec-80)	40-5-5,6	(Dec-80)
10-10-11,12	(Oct-79)	40-5-7,8	(Dec-80)
10-10-13,14	(Nov-78)	40-5-9,10	(Oct-79)
10-10-15,16	(Dec-80)	40-5-11,12	(Dec-80)
10-10-17,18	(Nov-78)	40-5-13,14	(Oct-79)
10-10-19,20	(Nov-78)	40-5-15,16	(Dec-80)
10-10-21,22	(Nov-78)	40-5-17,18	(Dec-80)
10-10-23,24	(Nov-78)	40-10-1,2	(Nov-78)
10-10-25,26	(Nov-78)	40-10-3,4	(Oct-79)
10-10-27,28	(Dec-80)	40-10-5,6	(Feb-72)
10-10-29,30	(Oct-79)	40-15-1,2	(Dec-80)
10-10-31,32	(Nov-78)	40-15-3,4	(Jun-73)
10-10-33,34	(Dec-80)	40-15-5,6	(Aug-74)
10-15-1,2	(Dec-75)	40-15-7,8	(Sep-73)
10-15-3,4	(Oct-79)	40-15-9,10	(Dec-80)
10-20-1,2	(Nov-78)	40-15-11,12	(Sep-73)
10-25-1,2	(Feb-75)	40-15-13,14	(Feb-74)
10-25-3,4	(Mar-73)	40-15-15,16	(Dec-80)
10-25-5,6	(Mar-73)	40-20-1,2	(May-77)
10-25-7,8	(Mar-73)	40-20-3,4	(May-77)
10-25-9,10	(Mar-73)	40-20-5,6	(Oct-79)
		40-20-7,8	(May-77)
20-5-1,2	(Feb-72)	40-20-9,10	(Oct-79)
20-5-3,4	(Jan-71)	40-25-1,2	(Oct-79)
20-10-1,2	(Sep-73)	40-25-3,4	(Dec-80)
20-10-3,4	(Nov-78)	40-25-5,6	(Oct-79)
20-10-5,6	(Jun-73)	40-25-7,8	(May-77)
20-10-7,8	(Nov-78)		
20-10-9,10	(Nov-78)	50-5-1,2	(Dec-80)
20-10-11,12	(Nov-78)	50-10-1,2*	(Jan-71)
20-10-13,14	(Nov-78)	50-10-3,4*	(Oct-79)
20-10-15,16	(Nov-78)	50-10-5,6*	(Jan-71)
20-15-1,2	(Nov-78)	50-10-7,8*	(Dec-72)
20-15-3,4	(Nov-78)	50-10-9,10*	(Oct-79)
20-20-1,2	(Nov-78)	50-15-1,2*	(Jan-71)
20-25-1,2	(Nov-78)	50-15-3,4*	(Feb-72)
20-25-3,4	(Nov-78)	50-15-5,6*	(Jan-71)
20-30-1,2	(Nov-78)	50-15-7,8*	(Jun-73)
20-30-3,4	(Nov-78)	50-15-9,10*	(Dec-72)
20-30-5,6	(Dec-80)	50-15-11,12*	(Dec-72)
20-30-7,8	(Nov-78)	50-15-13,14*	(May-77)

*Vertical lines indicate pages included with this revision.*

*\*Delete these pages from your manual.*

50-20-1,2*	(Jan-71)	70-5-11,12	(Dec-80)	70-20-13,14	(Dec-80)
50-20-3,4*	(Jan-71)	70-5-13,14	(Dec-80)	70-20-15,16	(Nov-78)
50-25-1,2	(May-77)	70-5-15,16	(Dec-80)	70-20-17,18	(Dec-80)
50-25-3,4	(Dec-73)	70-6-1,2	(Jul-77)	70-20-19,20	(Nov-78)
50-30-1,2	(Jan-71)	70-6-3,4	(Jul-77)	70-20-21,22	(Nov-78)
50-30-3,4	(Jan-71)	70-6-5,6	(Jul-77)	70-25-1,2	(Jan-71)
50-30-5,6	(Jan-71)	70-6-7,8	(Jul-77)	70-25-3,4	(Feb-72)
50-30-7,8	(Jan-71)	70-6-9,10	(Oct-79)	70-25-5,6	(May-77)
50-30-9,10	(Jan-71)	70-6-11,12	(Oct-79)	70-25-7,8	(Dec-80)
50-30-11,12	(Jan-71)	70-6-13,14	(Jul-77)	70-30-1,2	(Jan-71)
50-30-13,14	(Oct-79)	70-6-15,16	(Jul-77)	70-30-3,4	(Jan-71)
50-30-15,16	(Dec-80)	70-6-17,18	(Jul-77)	70-30-5,6	(Jan-71)
50-30-17,18	(Dec-80)	70-6-19,20	(Oct-79)	70-30-7,8	(Nov-78)
50-30-19,20	(Nov-78)	70-6-21,22	(Jul-77)	70-30-9,10	(Nov-78)
50-30-21,22	(Oct-79)	70-6-23,24	(Jul-77)	70-35-1,2	(Feb-72)
50-30-23,24	(Nov-78)	70-6-25,26	(Oct-79)	70-35-3,4	(Jan-71)
50-30-25,26	(Nov-78)	70-6-27,28	(Oct-79)	70-35-5,6	(Jan-71)
50-30-27,28	(Nov-78)	70-6-29,30	(Oct-79)	70-35-7,8	(Dec-75)
50-30-29,30	(Nov-78)	70-6-31,32	(Jul-77)	70-36-1,2	(Dec-75)
50-30-31,32	(Oct-79)	70-6-33,34	(Jul-77)	70-40-1,2	(Feb-75)
50-30-33,34	(Nov-78)	70-10-1,2	(Oct-79)	70-40-3,4	(Feb-75)
50-30-35,36	(Oct-79)	70-10-3,4	(Dec-80)	70-40-5,6	(May-77)
50-30-37,38	(Oct-79)	70-10-5,6	(Oct-79)	70-40-7,8	(May-77)
50-35-1,2	(May-77)	70-10-7,8	(Dec-80)	70-40-9,10	(May-77)
50-35-3,4	(Oct-79)	70-15-1,2	(Dec-80)	70-40-11,12	(Oct-79)
50-40-1,2	(Oct-79)	70-15-3,4	(Dec-80)	70-40-13,14	(Oct-79)
50-40-3,4	(May-77)	70-15-5,6	(Dec-80)	70-40-15,16	(Dec-75)
50-40-5,6	(May-77)	70-15-7,8	(Dec-80)		
50-40-7,8	(May-77)	70-15-9,10	(Dec-80)	80-5-1,2	(Dec-75)
50-40-9,10	(Dec-80)	70-15-11,12	(Dec-80)	80-5-3,4	(Oct-79)
50-40-11,12	(Nov-78)	70-15-13,14	(Dec-80)	80-5-5,6	(Oct-79)
50-45-1,2	(Dec-75)	70-15-15,16	(Dec-80)	80-10-1,2	(Dec-73)
		70-15-17,18	(Dec-80)	80-15-1,2	(Jun-73)
60-5-1,2	(Jan-71)	70-15-19,20	(Dec-80)	80-15-3,4	(Dec-73)
		70-20-1,2	(Nov-78)	80-20-1,2	(Dec-80)
70-5-1,2	(Dec-80)	70-20-3,4	(Nov-78)	80-20-3,4	(Dec-75)
70-5-3,4	(Dec-80)	70-20-5,6	(Feb-75)		
70-5-5,6	(Nov-78)	70-20-7,8	(Dec-72)	Index-1,2	(Dec-80)
70-5-7,8	(Dec-80)	70-20-9,10	(Dec-73)	Index-3,4	(Dec-80)
70-5-9,10	(Dec-80)	70-20-11,12	(Nov-78)	Index-5,6	(Dec-80)

Vertical lines indicate pages included with this revision.  
 \*Delete these pages from your manual.

# Section 10 GENERAL

## CONTENTS OF THIS SECTION

	Page		Page
GROUP 5 - SPECIFICATIONS		GROUP 25 - SEPARATION	
General Machine Specifications .....	5-2	Removing and Installing	
GROUP 10 - PREDELIVERY, DELIVERY, AND		Backhoe .....	25-1
AFTER-SALES SERVICE		Removing and Installing	
Predelivery Service .....	10-1	Loader .....	25-2
Delivery Service .....	10-16	Removing and Installing Engine .....	25-3
After-Sales Inspection .....	10-16	Removing and Installing Engine	
GROUP 15 - TUNE-UP		from Front End .....	25-5
Preliminary Engine Testing .....	15-1	Removing and Installing Clutch	
Engine Tune-Up .....	15-1	Housing .....	25-6
Final Engine Test .....	15-3	Removing and Installing Final	
Unit Tune-Up .....	15-3	Drives .....	25-8
GROUP 20 - LUBRICATION		Torque Values .....	25-9
Periodic Service Charts .....	20-1	Special Tools .....	25-9
Engine Lubricating Oil .....	20-2		
Transmission-Hydraulic Oil .....	20-2		
Greases .....	20-2		

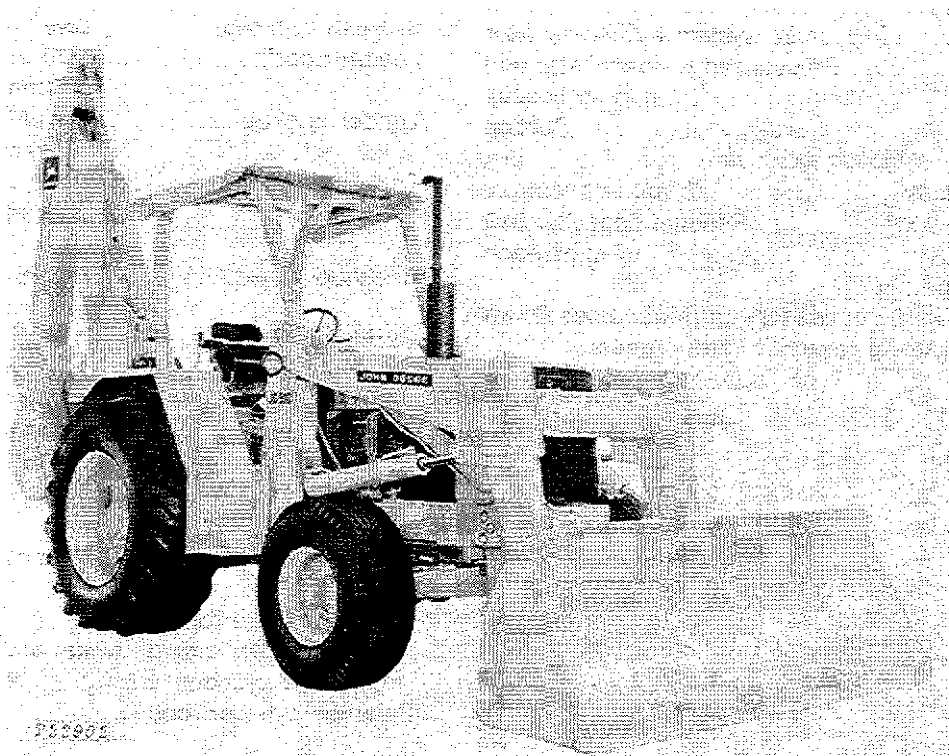

JD510 Backhoe Loader

# Group 5 SPECIFICATIONS

## JD510 BACKHOE LOADER SPECIFICATIONS

(Specifications and design subject to change without notice. Wherever applicable, specifications are in accordance with ICED and SAE Standards. Except where otherwise noted, these specifications are based on a unit equipped with 1-1/8 cu. yd. (0.86 m<sup>3</sup>) loader bucket, 24 in. (610 mm) backhoe bucket and standard equipment.)

**Power** (@ 2500 engine rpm):      **SAE**                      **DIN**  
Gross ..... 83 hp (61.9 kW\*)  
Net ..... 80 hp (59.7 kW)                      85.0 PS

Net engine flywheel power is for an engine equipped with fan, air cleaner, water pump, lubricating oil pump, fuel pump, alternator and muffler. Gross engine power is without fan. Flywheel power ratings are under SAE standard conditions of 500 ft. altitude and 85°F. temperature and DIN 70 020 standard conditions of 760 mm Hg barometer (sea level) and 20°C temperature. \*In the International System of Units (SI), power is expressed in kilowatts (kW).

**Engine:** John Deere diesel, 4-cylinder, 4-stroke cycle  
Bore and stroke ..... 4.25x4.75 in. (108x121 mm)  
Piston displacement ..... 270 cu. in. (4425 cm<sup>3</sup>)  
Compression ratio ..... 17.3 to 1  
Maximum torque

    @ 1300 rpm ..... 202 lb-ft (274 Nm) (27.9 kg-m)  
NACC or AMA (U.S. Tax) horsepower ..... 28.9  
Main bearings ..... 5

Lubrication ..... Pressure system w/full-flow filter  
Cooling ..... Pressurized w/thermostat and fixed bypass

Fan ..... Suction

Air cleaner w/restriction indicator ..... Dry

Electrical system ..... 12 volt w/alternator

Batteries (two volt) ..... Reserve capacity: 340 minutes each

### Transmission

Full Power Shift. 8 speeds forward, 4 reverse: Power shift from forward to reverse in first 4 gears.

Gear:	Travel Speeds:	
	mph	km/h
Forward 1	1.7	2.7
2	2.4	3.9
3	3.8	6.1
4	4.9	7.9
5	6.3	10.1
6	8.1	13.0
7	10.8	17.4
8	18.0	29.0
Reverse 1	2.0	3.2
2	2.8	4.5
3	4.4	7.1
4	5.7	9.2

**Final Drives** ..... Inboard, planetary

**Brakes** ... Hydraulically power actuated, fully enclosed wet-disk. Self-equalizing. Foot-operated individually or simultaneously.

### Steering: Power

Turning radius (brake applied) .. 11 ft. 2 in. (3.40 m)

Loader clearance (brake applied).... 31 ft. (9.45 m)

Number of turns, far left to far right ..... 3.3

### Hydraulic System: Closed-center

Max. Pressure ..... 2350 psi 16 203 kPa (162 bar)

Load control ..... Single-lever

Backhoe control ..... Two-lever

Pump... Piston, constant pressure, variable-displacement, 60 gpm (227 L/min) @ 2500 engine rpm

Filter ..... 25 micron steel-enclosed paper cartridge in return

Hydraulic Cylinders:	Bore	Stroke
Loader boom .....	3.75 in. (95 mm)	28.7 in. (729 mm)
Loader bucket .....	3.5 in. (89 mm)	27.3 in. (693 mm)
Backhoe boom .....	3.5 in. (140 mm)	41.75 in. (1060 mm)
Backhoe crowd .....	5.5 in. (140 mm)	37.5 in. (953 mm)
Backhoe bucket .....	4 in. (102 mm)	37.5 in. (953 mm)
Backhoe swing .....	4.5 in. (114 mm)	9.9 in. (251 mm)
Stabilizer .....	4.5 in. (114 mm)	21.5 in. (546 mm)

Cylinder rods.. Ground, heat-treated, chrome-plated, polished

Loader cylinder rods ..... 2 in. (51 mm) dia.

Backhoe boom, crowd, bucket and stabilizer cylinder rods ..... 2.5 in. (64 mm) dia.

Backhoe cylinder rods..... 2 in. (51 mm) dia.



**Tires:**

Front: 14.5/75-16.1, 10 ply rating, F3  
 Rear: 18.4-28, 12 ply rating, R4

**Wheel Treads:**

Front ..... 70.34 in. (1.79 m)  
 Rear ..... 65.5 in. (1.66 m)

**Capacities:**

	U.S.	Imp.	Liters
Cooling system	4.75 gal.	4.0 gal.	18.0
Fuel tank	34 gal.	28.3 gal.	128.7
Engine lubrication, including filter	8 qt.	6.7 qt.	7.6
Transmission and hydraulic system	29.9 gal.	25.0 gal.	113.2

**OPERATING INFORMATION**

**Loader:**

Rollback at ground level ..... 40 deg.  
 Breakout force ..... 10,000 lb. (44.82 kN) (4 536 kg)  
 Digging depth below ground level (with  
 bucket level) ..... 4 in. (102 mm)  
 Lifting capacity, full height ..... 6000 lb. (2 722 kg)  
 Height to bucket hinge pin ..... 10 ft. 7 in. (3.23 m)  
 Maximum dump angle ..... 45 deg.  
 Clearance, bucket dumped  
 at 45 degrees ..... 8 ft. 6 in. (2.59 m)  
 Reach at maximum height, bucket dumped  
 at 45 degrees ..... 2 ft. 4 in. (711 mm)  
 Raising time to full height ..... 5.6 sec.  
 Bucket dump time ..... 3.0 sec.  
 Lowering time (power) ..... 3.7 sec.

**Backhoe:**

**Digging depth (ICED):**

Maximum ..... 17 ft. 3 in. (5.26 m)  
 2 ft. (610 mm) flat bottom ..... 17 ft. 2 in. (5.23 m)  
 8 ft. (2.44 m) flat bottom ..... 16 ft. 5 in. (5.0 m)  
 Swing arc ..... 180 deg.

**Lifting capacity:**

Boom at full reach and  
 full height ..... 2400 lb. (1 089 kg)  
 Dipper lifting, boom holding,  
 full height ..... 4000 lb. (1 814 kg)

**Digging force (bucket cylinder**

in power-dig  
 position) ..... 12,662 lb. (56.75 kN) (5 743 kg)

**Digging force, crowd**

cylinder ..... 8811 lb. (39.49 kN) (3 997 kg)

**Reach from center of**

swing mast ..... 22 ft. 3 in. (6.78 m)

**Reach from center of**

rear axle ..... 25 ft. 11 in. (7.90 m)

**Loading height (truck-loading**

position) ..... 13 ft. 8 in. (4.17 m)

Transport height ..... 13 ft. 3 in. (4.04 m)

Bucket rotation ..... Adjustable for 148 or 161 deg.

Bucket positions .. Adjustable for 19 or 8 deg. rollback

**Stabilizer Width:**

Transport position ..... 7 ft. 8 in. (2.3 m)  
 Operating position (overall) ..... 13 ft. 4 in. (4.06 m)  
 Operating position (ICED) ..... 12 ft. (3.66 m)

**Buckets:**

Loader	Nominal Heaped Capacity	Width
	1-1/8 cu. yd. (0.86 m <sup>3</sup> )	90.5 in. (2.30 m)
	1-1/2 cu. yd. (1.15 m <sup>3</sup> )	94 in. (2.39 m)

Backhoe	Struck Capacity	Width
	8 cu. ft. (0.227 m <sup>3</sup> )	18 in. (457 mm)
	10 cu. ft. (0.283 m <sup>3</sup> )	24 in. (610 mm)
	12 cu. ft. (0.340 m <sup>3</sup> )	30 in. (762 mm)
	14 cu. ft. (0.396 m <sup>3</sup> )	36 in. (914 mm)

JD510 BACKHOE LOADER DIMENSIONS

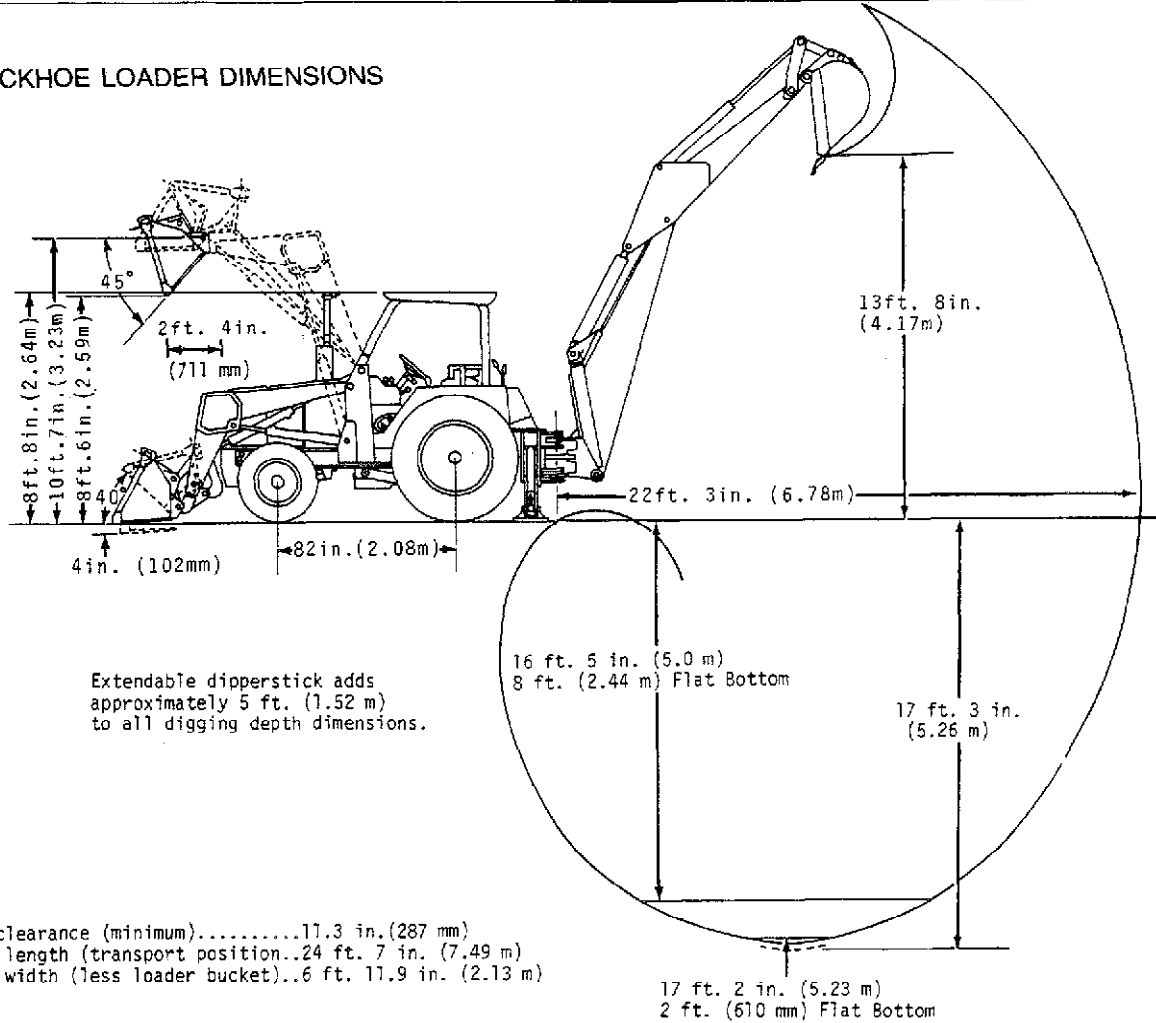

T57844N

**Additional Standard Equipment:**

- Vertical muffler w/rain cap
- Differential lock
- Fuel gauge
- Lights
- Oil pressure indicator light
- Alternator charge indicator light
- Water temperature gauge
- Transmission oil pressure indicator light
- Cigar lighter
- Transmission oil temperature gauge
- Tachometer
- Key switch w/push-button safety start
- Fenders
- Vandal protection
- Horn
- Hand throttle
- Foot throttle
- Electric hour meter
- Deluxe swing-around seat
- Antifreeze
- Cold weather starting aid

- Bucket level indicator
- Rear reflector
- Transistorized voltage regulator
- Flat deck w/skid-proof platform

**SAE Operating Weight . . . . . 20,560 lb. (9 326 kg)**

**Special Equipment:**

- ROPS w/canopy and seat belt
- Cab (includes ROPS and seat belt)
- Heater
- Defroster
- Pressurizer for cab
- Exhaust extension
- Bolt-on stabilizer street pads
- Extendable dipperstick
- Reversible stabilizer pads
- Parking brake w/warning system
- Backup alarm
- ADCO buckets for backhoes
- Seat belt—3 in. (76 mm)

# Group 10 PREDELIVERY, DELIVERY, AND AFTER-SALE SERVICES

## TEMPORARY UNIT STORAGE

After receiving your unit from the factory and before putting the machine into temporary storage, perform the following checks and services.

For long term storage (over 30 days) information, consult your JD510 operator's manual.

1. Check battery electrolyte level and charge the battery, if necessary.
2. Check coolant level: maintain 1-1/2 in. above header plate in tank top.
3. Fill the fuel tank.
4. Check crankcase oil level. Oil should be between marks on dipstick after machine has been shut down for 10 minutes.
5. Relieve hydraulic pressure by stopping engine, lowering backhoe and loader to ground, and operating control levers and steering wheel until system fails to respond.
6. Reduce shipping pressure of all tires to inflation pressure shown on page 10-10-14.
7. Cover unit for protection and cleanliness.

## PREDELIVERY SERVICE

Because of the shipping factors involved, plus extra finishing touches that are necessary to promote customer satisfaction, proper predelivery service is of prime importance to the dealer and the customer.

If adjustments are required, procedures are found in the after-sale section.

Use the following list when preparing a backhoe loader for delivery to the customer.

### 1. Cab Accessories

Check operation of windshield wiper, horn, seat belt, pressurizer, heater, defroster, dome light, etc.

Cab accessories checked Yes No

### 2. Lights

Check operation of all lights.

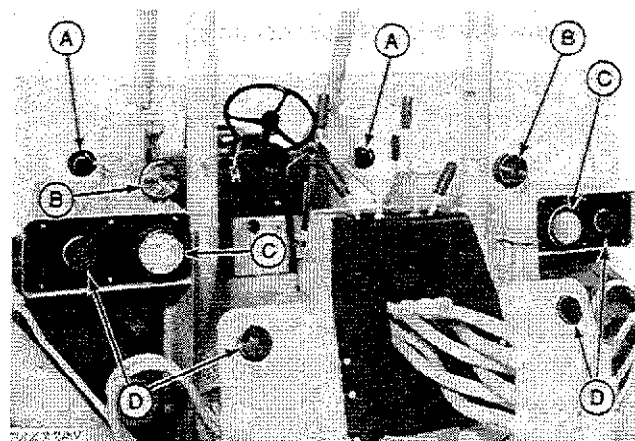

A—Loader Frame Headlights      C—Combination Rear Lamps  
B—Warning Lamps                  D—Reflectors

Fig. 1-Backhoe Loader Lights

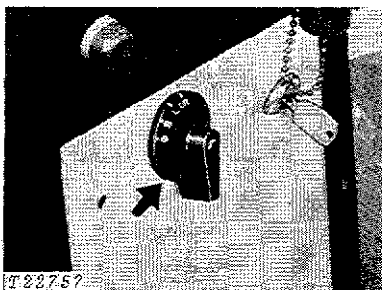

Fig. 2-Light Switch

When key switch is turned clockwise to ON, light switch will turn on all machine lights. The light switch has four positions:

- "L" - To turn on all headlights (High) and rear work lights.
- "B" - To turn on all headlights (High), tail lights and flashing warning lamps.
- "D" - To turn on headlights (Dim), tail lights and flashing warning lamps.
- "OFF" - To turn off all lights.

Lights checked Yes No

### 3. Seat

Check operation of seat controls.

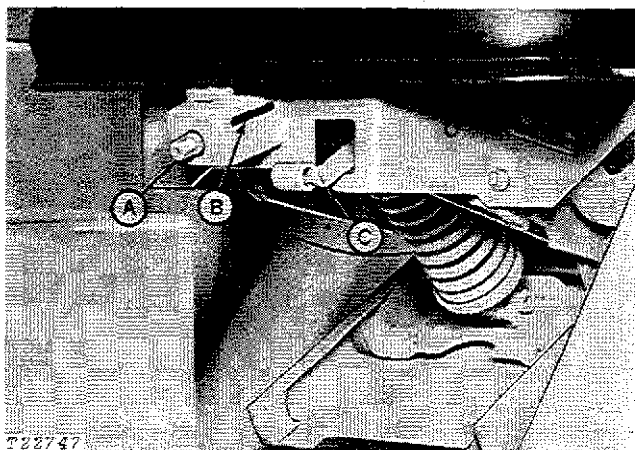

A—Weight Adjusting Screw      C—Seat Release Latch  
 B—Indicator

Fig. 3-Seat Controls

To move the seat up and back, stand up and lift seat release latch. The seat will move automatically to upper rear position. Sit down to return seat to preset operating position.

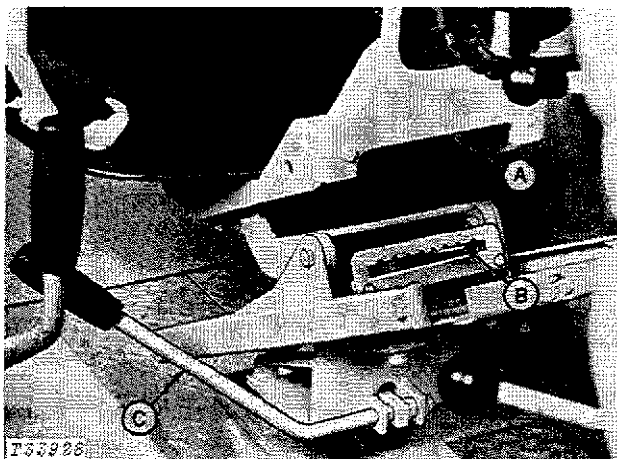

A—Counterbalance Shaft      C—Seat Pivot Release Lever  
 B—Seat Position Selector Lever

Fig. 4-Seat Controls

To adjust for height, move seat to upper, rear position. Then shift seat position selector lever between "short" and "tall" until pedals and levers can be operated comfortably when you are seated. The seat will always return to this position when you sit down after having moved the seat up to the rear.

To adjust for weight, turn weight-adjusting screw clockwise or counterclockwise until indicator conforms to your weight.

To change position of seat for either backhoe or loader operation, raise pivot release lever and turn seat until it locks into new position.

If seat does not move fully to rear when unlatched, adjust counterbalance spring as follows: Move seat to upper rear position. Insert a screwdriver in slot in counterbalance shaft, push in to unlatch shaft, and turn shaft counterclockwise. Align latch in end of shaft with one of the pairs of slots in the side of seat support and pull screwdriver outward to latch shaft.

Seat operation checked Yes No

### 4. Indicator Lights

Check operation of indicator lights. All four indicator lights (Figs. 5-8) glow when key switch is turned to ignition.

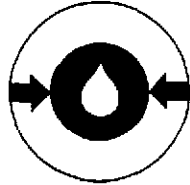

T22735

Fig. 5-Engine Oil Pressure Indicator Light

If light glows red when engine is running, stop engine immediately and determine cause.



T22740

Fig. 6-Transmission Oil Filter Indicator Light

After engine starts, light may glow while transmission oil is cold. If light glows when oil is warm, stop engine and change transmission filter element.

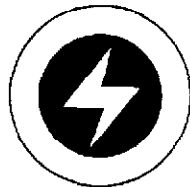

T22737

Fig. 7-Alternator Indicator Light

Light glows red when alternator is not charging. When light goes on with engine running, stop engine and determine cause.



T22739

Fig. 8-Air Filter Indicator Light

If light stays on after engine starts, clean and service air cleaner element.

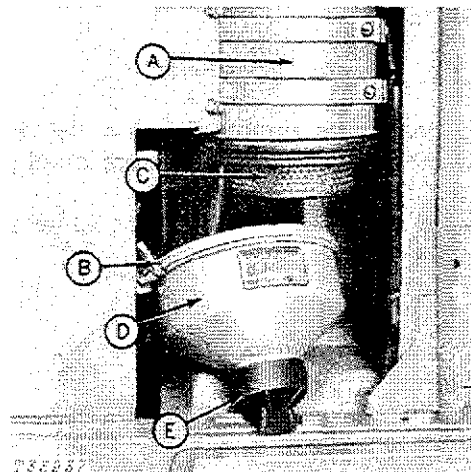

A—Air Cleaner Body  
 B—Clamp  
 C—Element

D—Dust Cup  
 E—Unloader Valve

Fig. 9-Air Cleaner

Check for restrictions. Replace element if necessary.

**NOTE:** Indicator light will not signal correctly if the element is ruptured or improperly sealed in air cleaner housing.



T62796N

Fig. 10-Parking Brake Indicator Light

Indicator light will glow when key switch is on and parking brake is engaged.

Indicator lights checked	Yes	No
Air filter element cleaned	Yes	No

## 5. Gauges

Check operation of gauges.

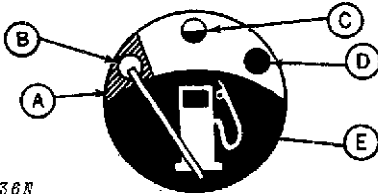

T22736N

A—Warning Zone  
 B—Empty Tank  
 C—Half-Full Tank

D—Full Tank  
 E—Fuel

Fig. 11-Fuel Gauge

Fuel gauge shows amount of fuel in fuel tank. Fill fuel tank with proper fuel. Check operation of gauge.

Open fuel tank drain cock. Drain liquid for several seconds. Close drain cock.



T22741

Fig. 12-Engine Coolant Temperature Gauge

White zone shows normal operating temperature. If indicator hand enters red-orange warning zone (striped area in Fig. 12), stop engine and determine cause.

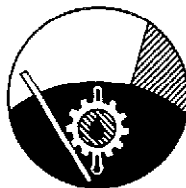

T22742

Fig. 13-Transmission Oil Temperature Gauge

White zone shows normal operating temperature. If indicator hand enters red-orange warning zone (striped area in Fig. 12), stop engine and determine cause.

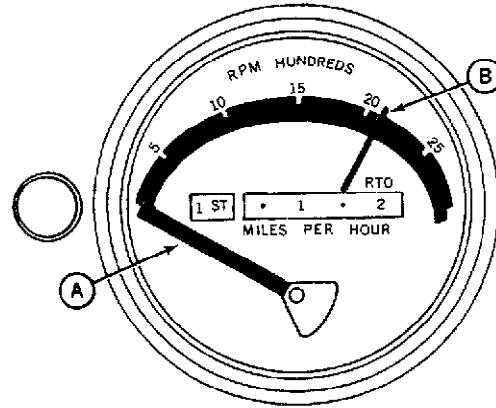

T57845N

Fig. 14-Tachometer

Pointer A shows miles per hour up to 22 mph.

Pointer B shows rpms up to 2650 rpm (fast idle).

Warm up engine and check engine speeds. Slow idle must be 800 rpm. Fast idle 2650 rpm.

If adjustment is needed, see page 10-10-20.

Gauges checked	Yes	No
Fuel tank filled	Yes	No
Fuel tank sediment drained	Yes	No
Engine speeds checked	Yes	No

## 6. Foot Controls

Check operation of all foot controls.

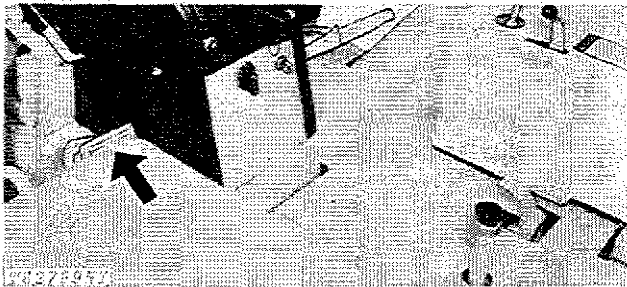

Fig. 15-Inching Pedal

While driving the backhoe loader, depress the inching pedal completely. The transmission should disengage the drive wheels.

If adjustment is needed see page 10-10-21.

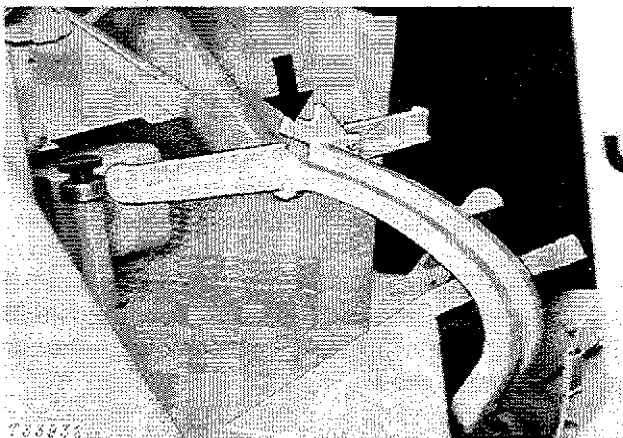

Fig. 16-Brake Pedals and Pedal Bar

Check brake system for leaks or improper operation.

Put backhoe loader in gear and depress brake pedal. Moderate pedal force should hold backhoe loader in place.

If pedal force does not hold backhoe loader in place, pedal feels spongy or bottoms out, repair is required, or system may require bleeding (page 10-10-21).

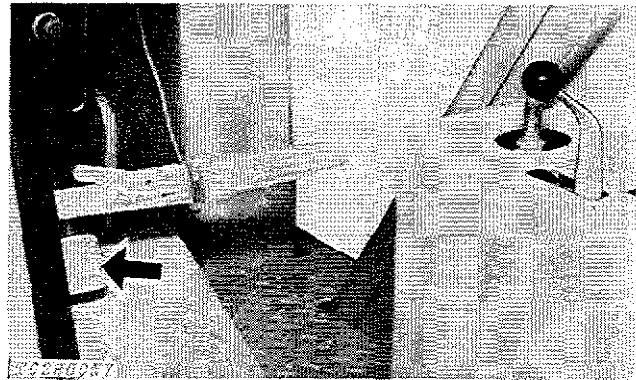

Fig. 17-Foot Throttle

Use foot throttle to speed up engine quickly, especially during loader operation when hands are busy with levers. When foot throttle is released, engine speed returns to hand throttle setting.

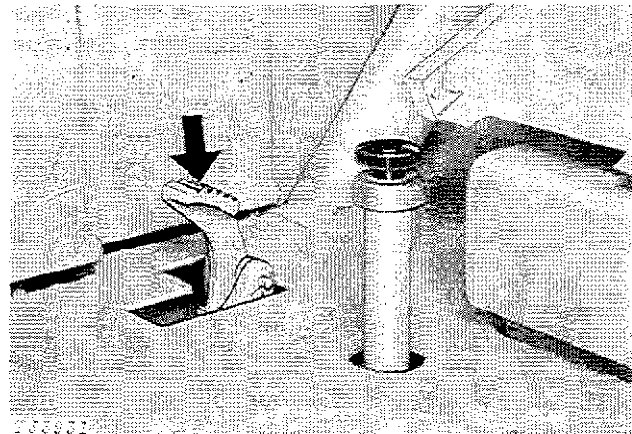

Fig. 18-Differential Lock Pedal

Run the engine. Put the transmission in park. Engage the differential lock. Turn the steering wheel. If the differential lock is working correctly, resistance will be felt.

To disengage differential lock, depress one or both brake pedals.

**CAUTION:** Do not attempt to turn or operate at high speed with differential lock engaged.

Foot controls checked

Yes No

## 7. Hand Controls

Check operation of all hand controls.

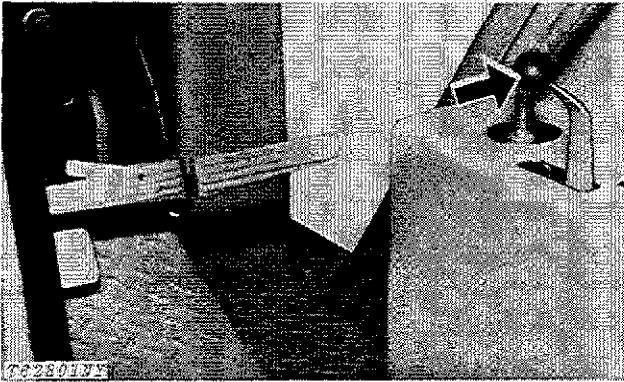
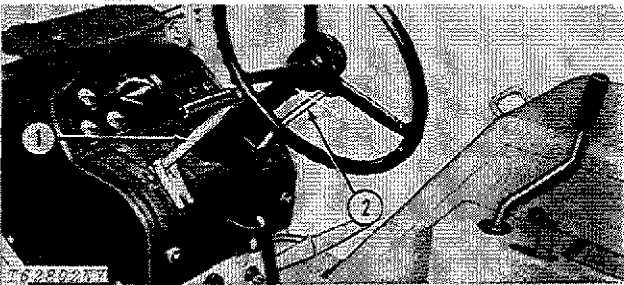

Fig. 19-Hand Throttle

Push throttle forward to speed up engine.

An adjustable throttle stop on the throttle lever bracket limits engine speed to 2200 rpm. The hand throttle can override this stop.



1—Reverser Lever                      2—Transmission Shift Lever

Fig. 20-Transmission Shift Controls

Check operation of transmission in all gears.

The power shift transmission can be shifted "on the go" or when the machine is stopped by moving the shift lever and reverser lever to the desired position. It is not necessary to use inching pedal when starting out or when shifting.

To move forward, push reverser lever into forward position and move shift lever to desired gear. Shift one gear at a time.

To reverse the machine when operating in one of the first four gears, pull the reverser lever rearward to the reverse (R) position. When shift lever is in 5th gear or higher, the reverser lever cannot be put in reverse.

A backup alarm sounds at intervals when machine is operated in reverse.

Reduce engine speed before making sudden speed changes. Use hand rail beside shift lever to aid shifting when traveling over rough ground.

The transmission speed of shift may be adjusted for rapid shift or smooth shift. See page 10-10-23.

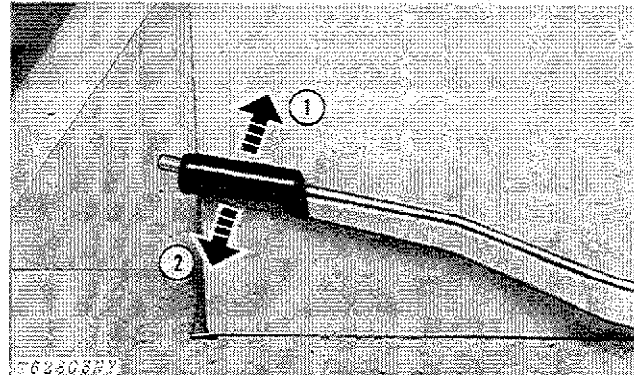

1—Engaged

2—Disengaged

Fig. 21-Parking Brake

1. To engage, pull up.
2. To disengage, press button and push lever down.

**NOTE:** Parking brake warning light will glow when key switch is on and parking brake is engaged. Horn will blow also if transmission is shifted from neutral with parking brake applied.

If adjustment is needed, see page 10-10-23.



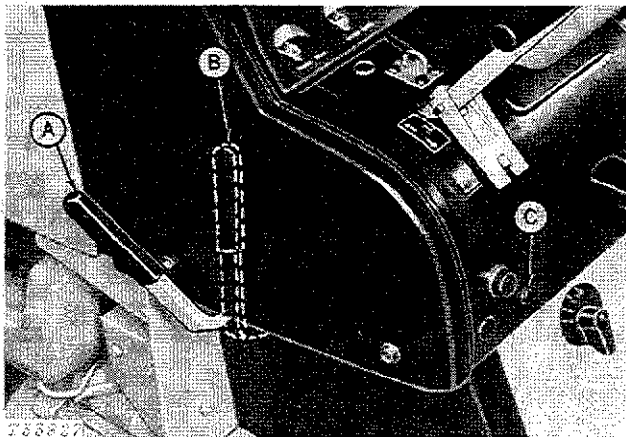

A—Engaged  
 B—Disengaged  
 C—Release Button

Fig. 22-Transmission Disconnect Lever

During cold weather, increase engine cranking speed by disengaging transmission from engine. Pull disconnect lever rearward until it is latched in disengaged position.

IMMEDIATELY after engine starts, engage lever by pulling it slightly rearward. Push release button in and allow lever to move forward to engaged position.

**IMPORTANT:** To avoid damage to main hydraulic pump, engage the disconnect clutch as soon as the engine starts.

Hand controls checked Yes No

## 8. Loader Control

Check operation of boom and bucket lever.

Boom and bucket lever operates when engine is running.

If the lever is released at any time during normal loader operation, it will return to neutral and the boom and bucket will be held in position reached at that time.

Push control lever all the way forward for float position. Lever will stay in this position until it is manually returned to neutral.

When lever is in float position, boom moves freely up or down as bucket follows contour of ground.

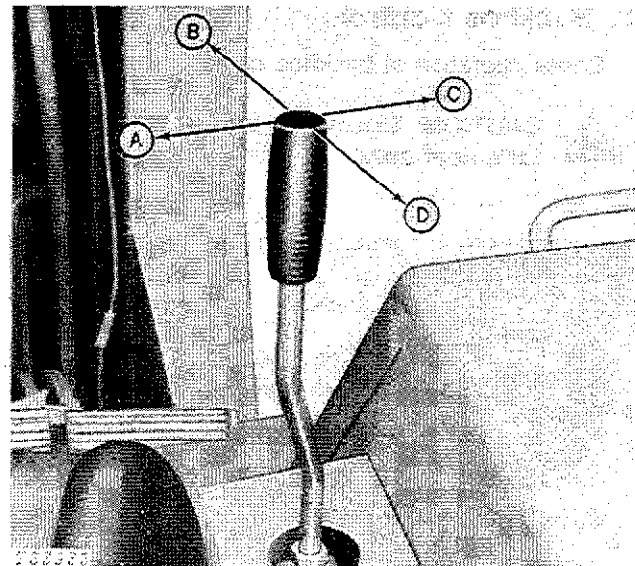

A—Retract Bucket  
 B—Lower Boom  
 C—Dump Bucket  
 D—Raise Boom

Fig. 23-Boom and Bucket Control Lever

Push lever to right to dump bucket. Push lever beyond stop for maximum speed.

For most accurate control and maximum power of the bucket cutting edge, do not move control lever beyond the stop.

When retracting the bucket, move lever all the way left for maximum power.

**IMPORTANT:** Do not hold lever in power position A or C after cylinder has completed its stroke.

Loader control lever checked Yes No

## 9. Backhoe Controls

Check operation of backhoe control levers.

**CAUTION:** Operate backhoe from operator's seat only.

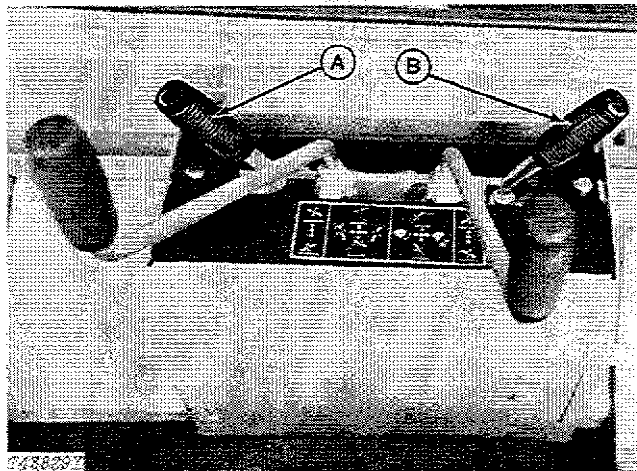

A—Left Stabilizer Lever      B—Right Stabilizer Lever

Fig. 24—Stabilizer Control Levers

The right and left stabilizer legs on each side of the main frame are individually controlled by two levers. The stabilizers may be raised or lowered individually, or at same time.

To lower stabilizers, move control levers forward. To raise them, pull levers rearward.

**CAUTION:** To avoid tipping when operating backhoe, extend stabilizer legs to widest position.

**CAUTION:** Use caution when raising the stabilizers. Remember that the stabilizers may be the only restraint preventing the machine from rolling into the excavation.

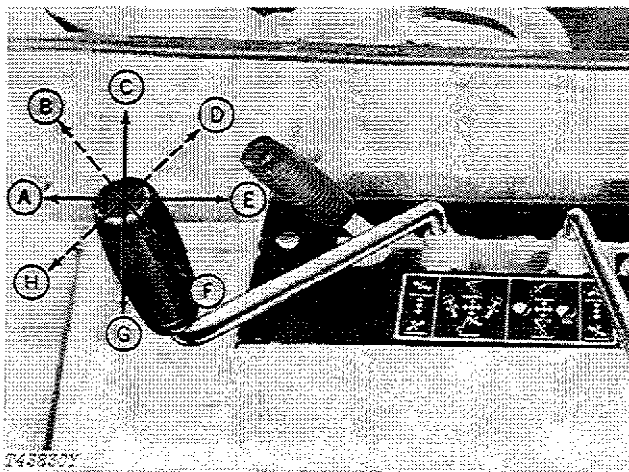

A—Left      E—Right  
B—Left and Down      F—Right and Up  
C—Down      G—Up  
D—Right and Down      H—Left and Up

Fig. 25—Boom Control Lever

Boom control lever raises or lowers boom, and swings it to left or right.

To lower boom push control lever forward. To raise boom move lever rearward. To swing left move lever left; to swing right move lever right.

Move lever to an intermediate position to swing boom left or right at same time it is being raised or lowered.

A swing brake, built into the swing cylinder, automatically slows boom before it strikes stops on main frame.

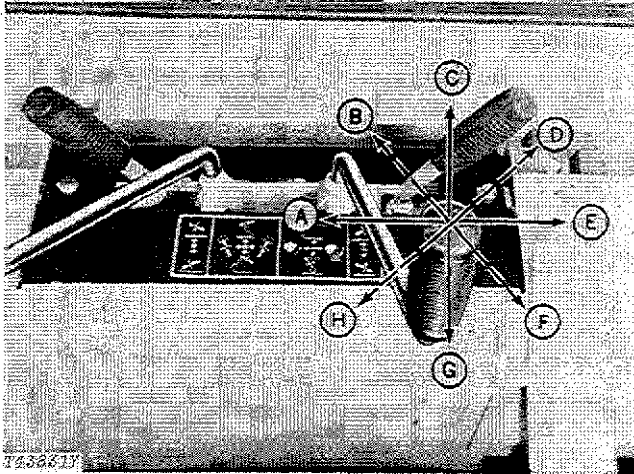

- |                |               |
|----------------|---------------|
| A—Load         | E—Dump        |
| B—Out and Load | F—In and Dump |
| C—Bucket Out   | G—Bucket In   |
| D—Out and Dump | H—In and Load |

Fig. 26-Bucket and Dipperstick Control Lever

To extend dipperstick (move bucket out) move control lever forward, to retract it (move bucket in) move lever rearward.

To dump bucket move control lever to right; to load it move lever to left.

Move lever to an intermediate position, to extend or retract dipperstick at same time bucket is being loaded or dumped.

Backhoe controls checked Yes No

## 10. Cycle Times

Check backhoe and loader hydraulic function cycle times.

Before checking loader functions cycle times, remove air from system as follows:

1. Operate the engine at 1/2 to 3/4 throttle and raise the boom to the top of its stroke, then lower to the bottom of its stroke (front of tractor off ground) three times. On the last cycle hold the handle in each direction after the boom has stopped and check for external leaks.

2. Operate the engine full throttle and place the bucket four feet off ground. Dump and roll back bucket three times. During the third cycle hold the handle in each direction at least five seconds after bucket has stopped and check for external leaks. With bucket fully dumped, raise boom to the top of its stroke to be sure that no lock-up occurs.

The following times should be used as a guide. If cycle times vary greatly from those listed, trouble shoot the hydraulic system. Check cycle times with oil warm and engine at fast idle.

### Backhoe cycle times:

- Bucket retract ..... 2.5 seconds max.
- Bucket extend ..... 3.5 seconds max.
- Swing (180 degrees) ... 3.5 to 7.0 seconds max.

### Loader cycle times:

- Boom raise ..... 5.7 seconds max.
- Boom lower (power) ..... 5.3 seconds max.
- Boom lower (float) ..... 7.5 seconds max.
- Bucket dump (boom at full height) ..... 4.2 seconds max.

Cycle times checked Yes No

## 11. Steering

Check power steering. Steering wheel should turn freely in both directions without jerking and excessive play.

If repair is needed, see Section 60.

Steering checked Yes No

## 12. Accumulator

Check the brake accumulator and hydraulic accumulator circuits.

**CAUTION:** Do not attempt to disconnect or remove the accumulator unless you release the hydraulic pressure. To do so, stop engine, loosen the right-hand brake bleed screw and hold the right-hand brake pedal down for a few minutes.

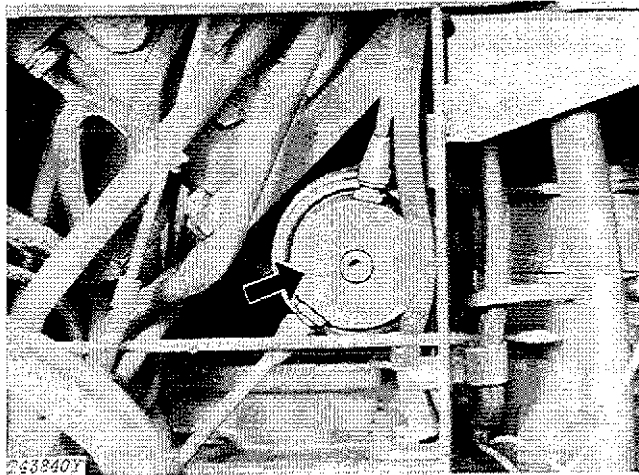

Fig. 27-Brake Accumulator

Check the accumulator brake circuit.

1. Run engine one minute minimum, or until transmission-hydraulic oil is at normal operating temperature.
2. Stop engine.
3. Wait 10 to 15 minutes.
4. Apply brakes five times at five second intervals.
5. If brakes stop working in five applications or fewer, the brake circuit needs service.

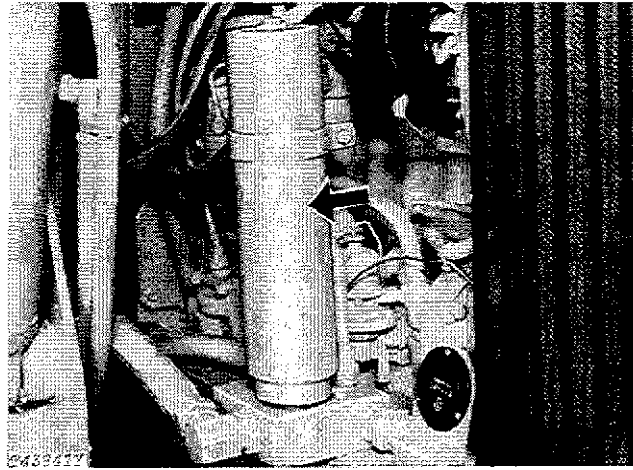

Fig. 28-Hydraulic System Accumulator

Check hydraulic system accumulator circuit as follows:

Start engine and run for one minute. Stop engine.

Turn steering wheel to left as far as possible. Power steering should be available for 1/2 to 3/4 steering wheel revolution. If not, the accumulator circuit may need service.

Accumulators checked Yes No

## 13. Air Intake Hoses

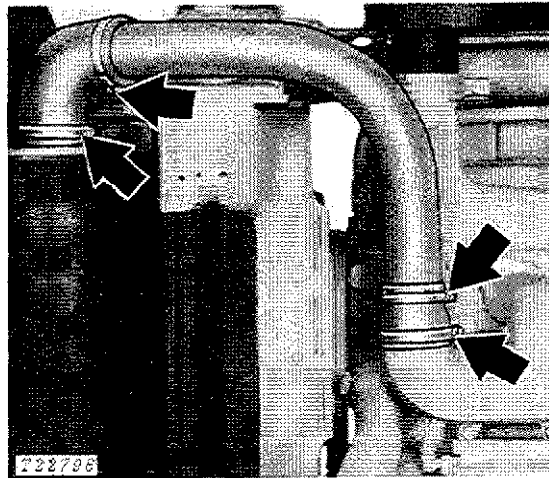

Fig. 29-Air Intake Hose Clamps

Check air hose clamps. Tighten clamps if necessary. Inspect hoses for damage.

Air intake hoses checked Yes No

### 14. Radiator

Check coolant level.

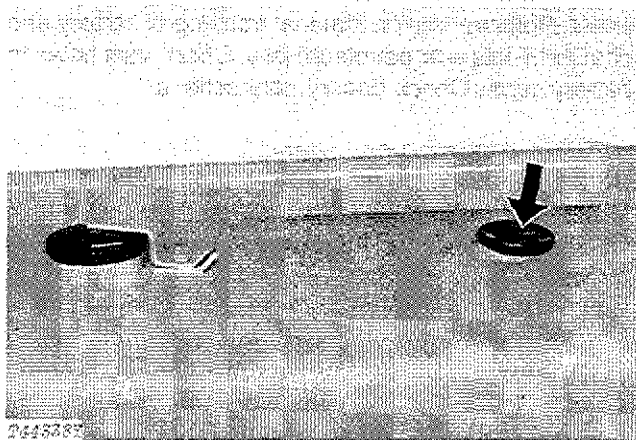

Fig. 30-Radiator Cap

**CAUTION:** Remove radiator filler cap only when coolant temperature is below boiling point. Then loosen cap slightly to the stop before removing the cap completely.

Check coolant level with unit on level ground. Add clean soft water (summer) or antifreeze (winter) if the coolant level is lower than 1-1/2 inches above the header plate in the radiator top tank.

Check cooling system for loose connections or leaks after adding coolant. Tighten the filler cap.

Coolant level checked Yes No

### 15. Crankcase Oil Level

Check crankcase oil level with unit on level ground. (Allow a minimum of 10 minutes for the oil to drain down before checking.) If oil level is at or below bottom mark on dipstick, add oil specified on page 10-20-2 to bring oil level to between marks on dipstick. Do not operate engine with oil level below bottom mark.

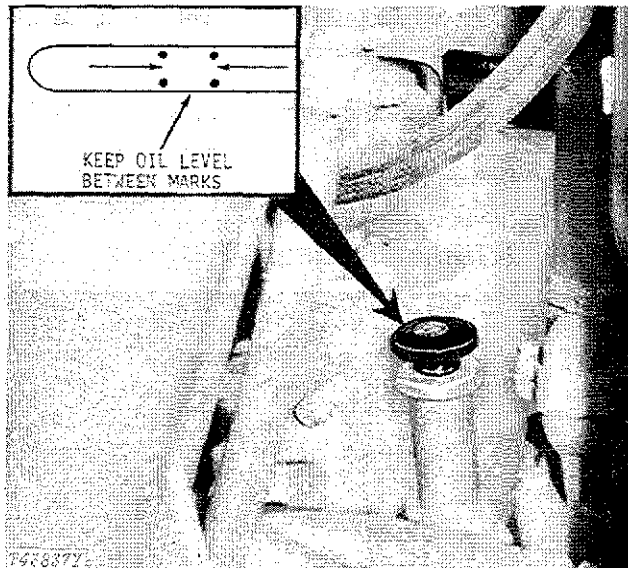

Fig. 31-Crankcase Filler Cap and Dipstick

Crankcase oil level checked Yes No  
 Oil added \_\_\_\_\_ qts.

### 16. Transmission Oil Level

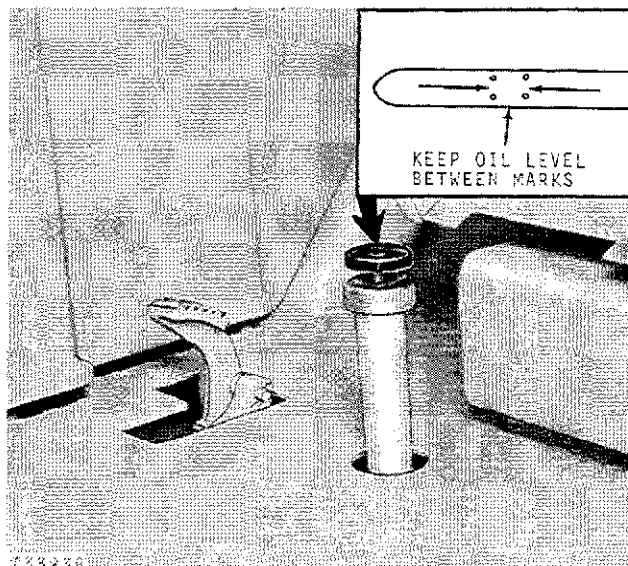

Fig. 32-Transmission Filler Cap and Dipstick

Park machine on level ground. Put transmission in park. Engage parking brake (if equipped). Put reverser lever in neutral. Lock it. Lower loader bucket to ground. Put backhoe in transport position. Run engine at slow idle 2 minutes with clutch engaged. Stop engine.

Check oil level on dipstick. Oil level should be between marks on dipstick.

If necessary add oil specified on page 10-20-2.

Transmission oil level checked \_\_\_\_\_ Yes No  
Oil added \_\_\_\_\_ qts.

### 17. Fuel Transfer Pump

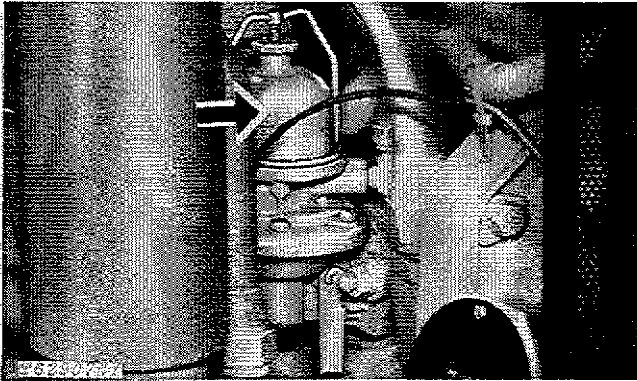

Fig. 33-Fuel Transfer Pump Sediment Bowl

Inspect fuel transfer pump sediment bowl. If there is water or an excess of foreign matter, remove and clean sediment bowl and fuel strainer. Install strainer and bowl, using a good gasket.

Sediment bowl checked \_\_\_\_\_ Yes No

### 18. Fuel Filter

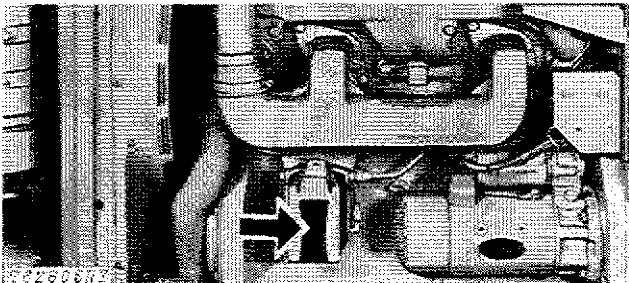

Fig. 34-Fuel Filter Element

Inspect fuel filter element for water and sediment. If necessary, loosen drain screw at bottom of filter body and drain liquid for several seconds. Tighten drain screw.

Bleed fuel system. See page 10-10-30.

Fuel filter checked \_\_\_\_\_ Yes No

### 19. Batteries

Check battery electrolyte level. If distilled water is not available, use clean soft water. Avoid use of hard water. Remove foreign material from top of battery and coat terminals with petroleum jelly. Check vent holes in battery caps. Check battery connections.

Punch date code on battery.

**IMPORTANT: Never add water to battery in freezing weather unless engine is to be run 2 or 3 hours.**

Batteries checked \_\_\_\_\_ Yes No

### 20. Engine Belts

Check alternator-fan belt tension.

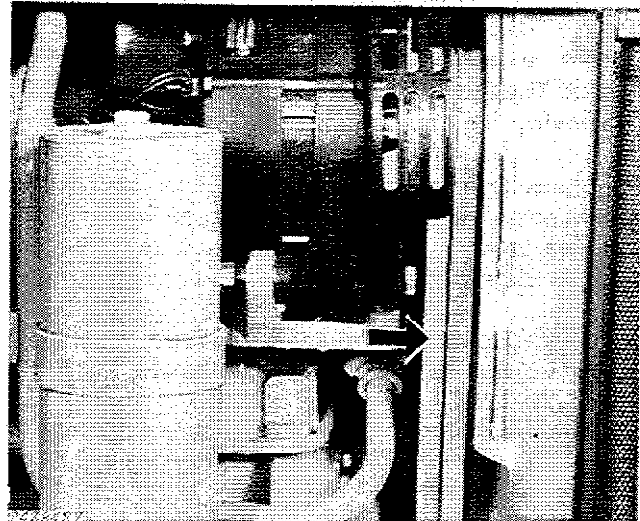

Fig. 35-Engine Belts

#### Checking Tension

Tension Gauge: Tighten new belts to 100 lb. and used belts to 90 lb. Check front belt only.

Tension Tester: Tighten belts until 20 lb. force midway between pulleys will deflect belt 1 in.

Immediately after shutdown, check tension with tension gauge. If tension is 50 lb. or less, wait 10 minutes then retension belts to 90 lb.

**Adjusting Tension**

Loosen mounting bolt and adjusting cap screw and apply force only to FRONT alternator frame.

Engine belts checked Yes No

**21. Lubrication**

The backhoe loader was checked and lubricated before it left the factory. However, to insure customer satisfaction, check each lubrication point shown in the following pages. Lubricate with several strokes of John Deere Multi-Purpose Grease or equivalent, if necessary.

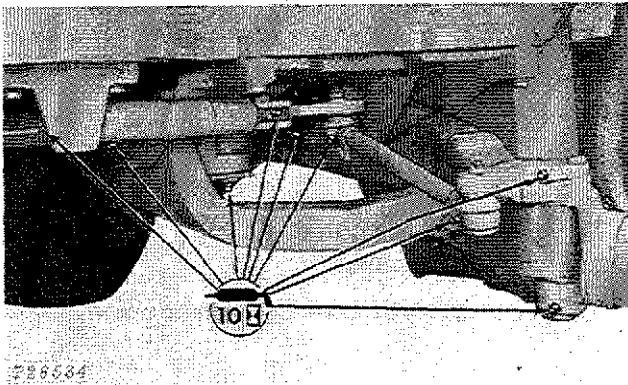

Fig. 36-Front Axle Fittings (15 points)

Lubrication required Yes No

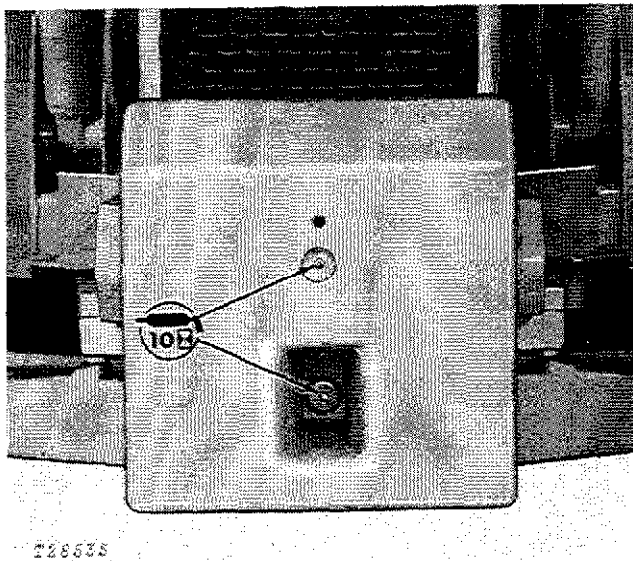

Fig. 37-Front Axle Grease Fittings (2 points)

Lubrication required Yes No

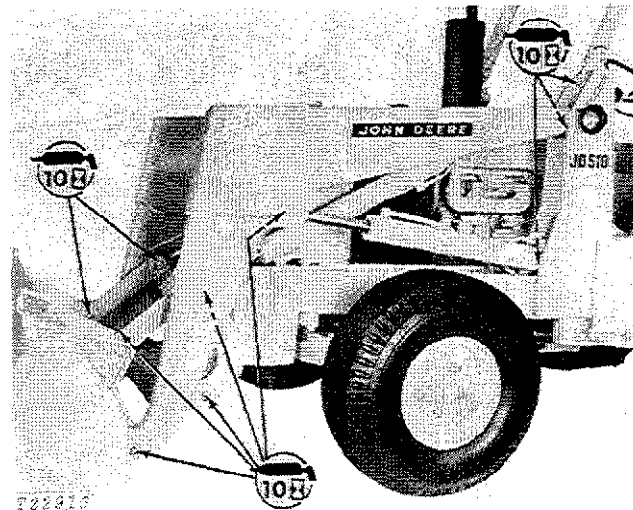

Fig. 38-Loader Pivot Points (15 Points)

Lubrication required Yes No

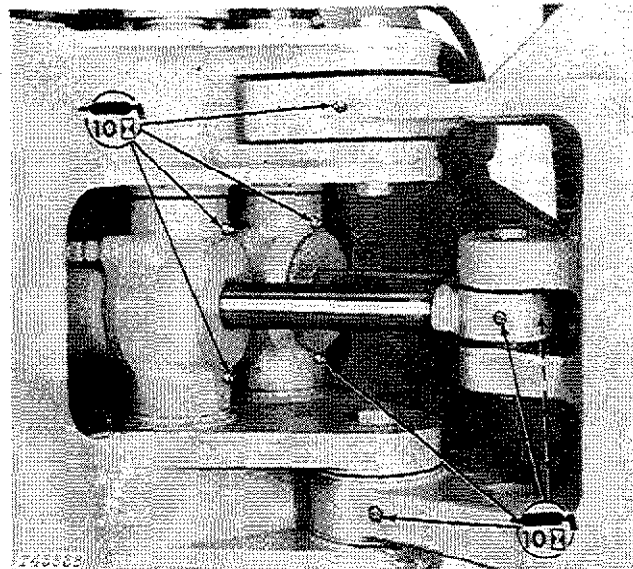

Fig. 39-Swing Cylinder Pivot Points (8 Points)

Lubrication required Yes No

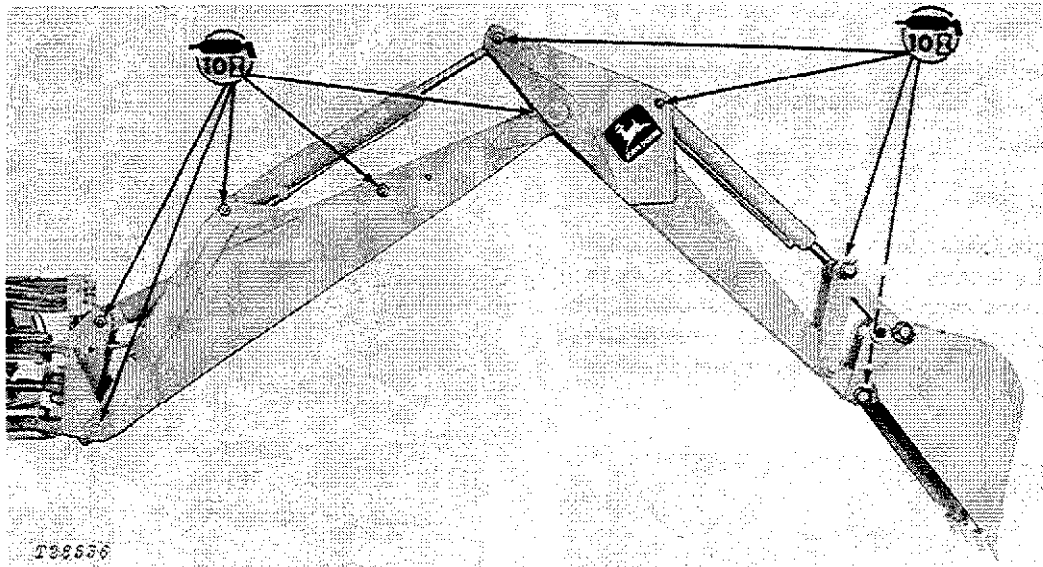

Fig. 40-Backhoe Pivot Points (9 Points)

Lubrication required

Yes No

**22. Tires**

Check tire pressure with an accurate gauge having 1 psi graduations.

Inflate tires according to chart below.

FRONT TIRES		
Tire Size	Ply Rating	Inflation Pressure psi
14.5/75 x 16.1	10	40
REAR TIRES		
18.4-28	12	30

Each front tire has 280 pounds of calcium chloride solution.

**IMPORTANT: Check front tire inflation using a special gauge for liquid ballast.**

Tire pressure checked

Yes No

**23. Bucket Position**

Be sure bucket is in power dig position shown below.

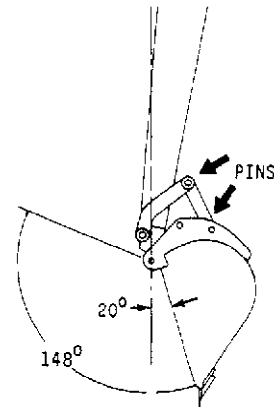

Fig. 41-Power Dig Position

Bucket position checked

Yes No



### 24. Toe-In

Check the toe-in of the front wheels.

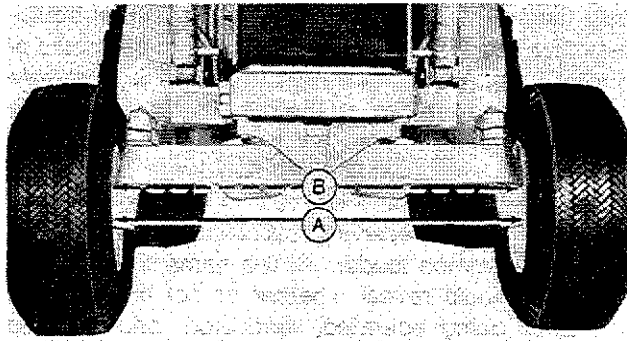

A—Tread at Front of Rim

B—Tread at Rear of Rim

Fig. 41A-Checking Toe-In

1. Use down pressure of loader bucket to raise front wheels. Turn wheels so each valve stem is at bottom of tire.
2. Lower wheels to ground.
3. Measure from ground to hub.
4. Mark this distance on inside of each rim at the bead of tire front (A) and rear (B).
5. Measure distance between rims at front and rear marks.
6. Distance between front of rims must be 1/8 to 3/8 in. (3 to 9.5 mm) less than distance between rear of rims.

If distance in step 6 is not correct, see page 10-10-33 for adjustment.

Toe-in checked Yes No

### 25. Special Hardware Torque

Check hardware listed below. Tighten to torque shown.

Front wheel bolts .....	100 lb-ft
Rear wheel bolts .....	300 lb-ft
Backhoe tapered pins .....	300 lb-ft

Hardware checked Yes No

### 26. Accessible Hardware Torque Values

Check all accessible bolts and nuts for proper tightness. If hardware is loose, tighten it to the proper torque. See torque chart on page 10-10-33.

Accessible hardware torqued Yes No

### 27. Fluid Leakage

Check the following systems for leakage due to poor or faulty connections and broken hoses or lines.

A. Cooling system checked	Yes	No
B. Hydraulic system checked	Yes	No
C. Transmission system checked	Yes	No
D. Fuel system checked	Yes	No

### 28. Final Check

The final predelivery procedure is the overall clean-up of the backhoe loader. Make the backhoe loader LOOK like a new backhoe loader with the proper touch-up of chipped paint and a good wash job. Deliver to the customer a backhoe loader anyone would be proud to own.

## DELIVERY SERVICE

A thorough discussion of the operation and service of this backhoe loader at the time of delivery helps to assure complete customer satisfaction. Proper delivery should be an important phase of a dealer's program. A portion of the John Deere Delivery Receipt emphasizes the importance of proper delivery service.

Many complaints arise because the owner was not shown how to operate and service the new backhoe loader properly. Devote enough time, at the customer's convenience, to introduce the owner to the new backhoe loader and explain how to operate and service it.

The following procedure is recommended before the service technician and owner complete the delivery acknowledgments portion of the Delivery Receipt.

Use the operator's manual as a guide to be sure that the owner understands these points thoroughly:

1. The importance of safety.
2. The importance of lubrication and periodic services.
3. The importance of the break-in period.
4. Controls and instruments.
5. How to start and stop the engine.
6. All functions of the hydraulic system.

After explaining and demonstrating the above features, have the owner sign the Delivery Receipt and give the owner the operator's manual.

## AFTER-SALE INSPECTION

The purchaser of a new John Deere backhoe loader is entitled to a free inspection at some mutually agreeable time within the warranty period after the equipment has been "run in," usually after 50 to 100 hours of backhoe loader operation. The terms of this after-sale inspection are outlined on the customer's John Deere Delivery Receipt.

The purpose of this inspection is to make sure that the customer is receiving satisfactory performance from the backhoe loader. At the same time, the inspection should reveal whether or not the backhoe loader is being operated, lubricated, and serviced properly.

If the recommended after-sale service inspection is followed, the dealer can eliminate a needless volume of service work by preventing minor irregularities from developing into serious problems later on. This will promote strong dealer-customer relations and present the dealer an opportunity to answer questions that may have arisen during the first few days of operation.

During the inspection service, the dealer has the further opportunity of promoting the possible sale of other new equipment.

Check operation of all controls and instruments for freedom of movement and correct operation.

### 1. Cab Accessories

Check operation of windshield wiper, horn, seat belt, pressurizer, heater, defroster, dome light, etc.

Cab accessories checked Yes No

### 2. Lights

Check operation of all lights.

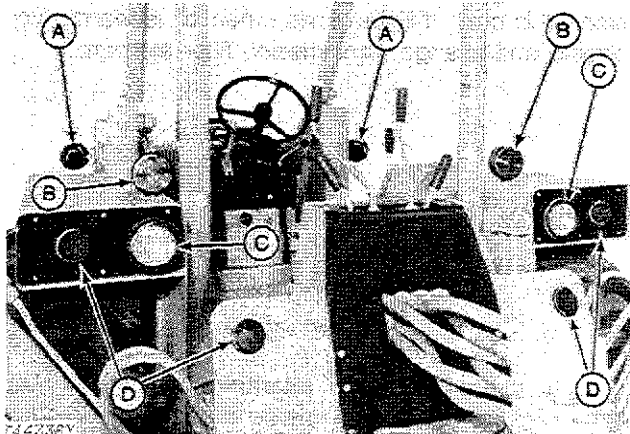

A—Loader Frame Headlights    C—Combination Rear Lamps  
 B—Warning Lamps            D—Reflectors

Fig. 42-Backhoe Loader Lights

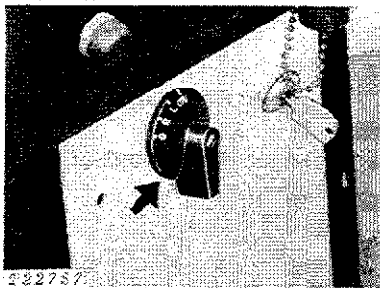

Fig. 43-Light Switch

When key switch is turned clockwise to ON, light switch will turn on all machine lights. The light switch has four positions:

“L” - To turn on all headlights (High) and rear work lights.

“B” - To turn on all headlights (High), tail lights and flashing warning lamps.

“D” - To turn on headlights (Dim), tail lights and flashing warning lamps.

“OFF” - To turn off all lights.

Lights checked Yes No

### 3. Seat

Check operation of seat controls.

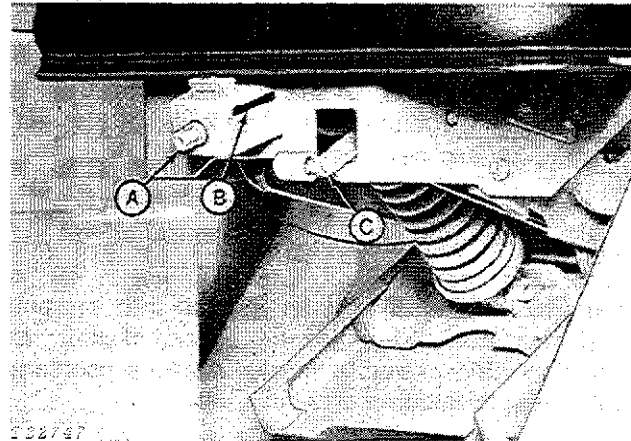

A—Weight Adjusting Screw            C—Seat Release Latch  
 B—Indicator

Fig. 44-Seat Controls

To move the seat up and back, stand up and lift seat release latch. The seat will move automatically to upper rear position. Sit down to return seat to preset operating position.

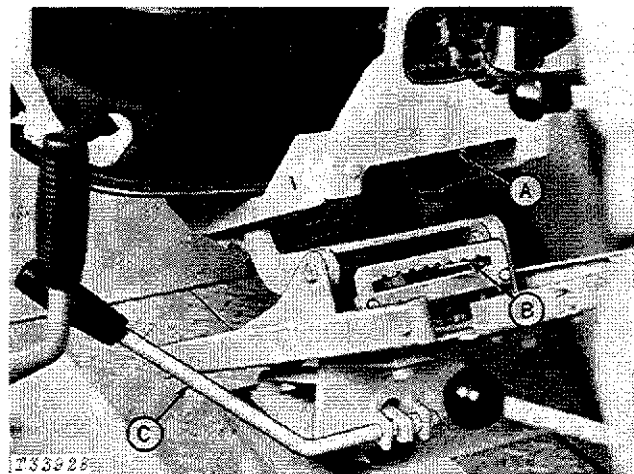

A—Counterbalance Shaft            C—Seat Pivot Release Lever  
 B—Seat Position Selector Lever

Fig. 45-Seat Controls

To adjust for height, move seat to upper, rear position. Then shift seat position selector lever between "short" and "tall" until pedals and levers can be operated comfortably when you are seated. The seat will always return to this position when you sit down after having moved the seat up to the rear.

To adjust for weight, turn weight-adjusting screw clockwise or counterclockwise until indicator conforms to your weight.

To change position of seat for either backhoe or loader operation, raise pivot release lever and turn seat until it locks into new position.

If seat does not move fully to rear when unlatched, adjust counterbalance spring as follows: Move seat to upper rear position. Insert a screwdriver in slot in counterbalance shaft, push in to unlatch shaft, and turn shaft counterclockwise. Align latch in end of shaft with one of the pairs of slots in the side of seat support and pull screwdriver outward to latch shaft.

Seat operation checked Yes No

#### 4. Indicator Lights

Check operation of indicator lights. All four indicator lights (Figs. 46-49) glow when key switch is turned to ignition.

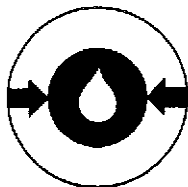

T22738

Fig. 46-Engine Oil Pressure Indicator Light

If light glows red when engine is running, stop engine immediately and determine cause.

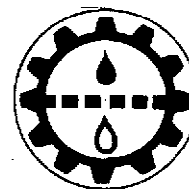

T22740

Fig. 47-Transmission Oil Filter Indicator Light

After engine starts, light may glow while transmission oil is cold. If light glows when oil is warm, stop engine and change transmission filter element.

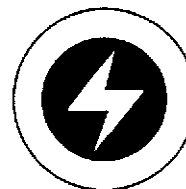

T22737

Fig. 48-Alternator Indicator Light

Light glows red when alternator is not charging. When light goes on with engine running, stop engine and determine cause.



T22739

Fig. 49-Air Filter Indicator Light

If light stays on after engine starts, clean and service air cleaner element.

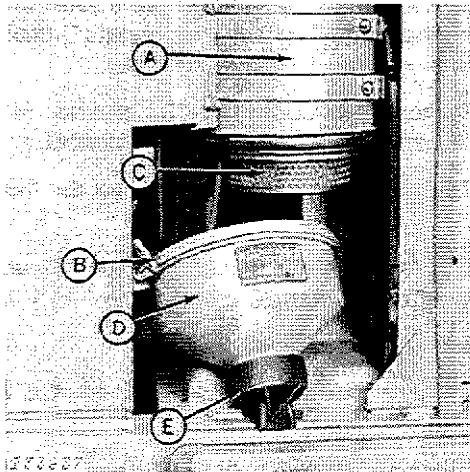

A—Air Cleaner Body  
 B—Clamp  
 C—Element  
 D—Dust Cup  
 E—Unloader Valve

Fig. 50-Air Cleaner

Check for restrictions. Replace element if necessary.

*NOTE: Indicator light will not signal correctly if the element is ruptured or improperly sealed in air cleaner housing.*



T22798N

Fig. 51-Parking Brake Indicator Light

Indicator light will glow when key switch is on and parking brake is engaged.

Indicator lights checked	Yes	No
Air filter element cleaned	Yes	No

## 5. Gauges

Check operation of gauges.

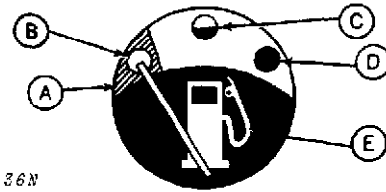

T22736N

A—Warning Zone  
 B—Empty Tank  
 C—Half-Full Tank  
 D—Full Tank  
 E—Fuel

Fig. 52-Fuel Gauge

Fuel gauge shows amount of fuel in fuel tank. Add a small amount of fuel to tank. Check movement of fuel gauge indicator.

Open fuel tank drain cock. Drain liquid for several seconds. Close drain cock.

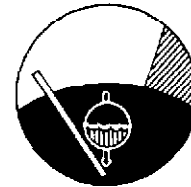

T22741

Fig. 53-Engine Coolant Temperature Gauge

White zone shows normal operating temperature. If indicator hand enters red-orange warning zone (striped area in Fig. 53), stop engine and determine cause.

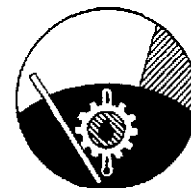

T22742

Fig. 54-Transmission Oil Temperature Gauge

White zone shows normal operating temperature. If indicator hand enters red-orange warning zone (striped area in Fig. 54), stop engine and determine cause.

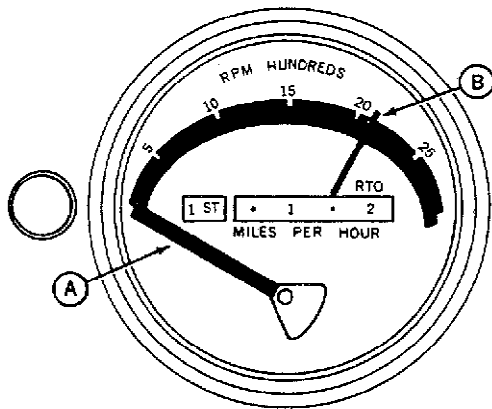

T57845N

Fig. 55-Tachometer

Pointer A shows miles per hour up to 22 mph.

Pointer B shows rpms up to 2650 rpm (high idle).

Warm up engine and check engine speeds. Slow idle must be 800 rpm. Fast idle 2650 rpm.

If adjustment is needed, warm up engine to operating temperature.

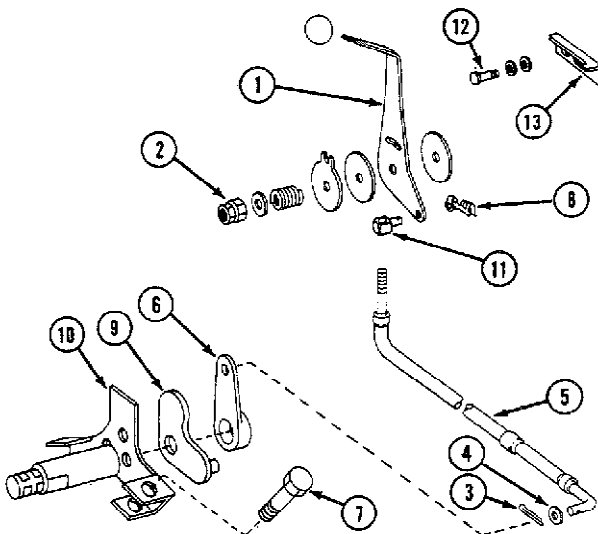

T62806N

- |                             |                        |
|-----------------------------|------------------------|
| 1—Throttle Lever            | 8—Clevis Clip          |
| 2—Special Nut               | 9—Throttle Shaft Lever |
| 3—Cotter Pin                | 10—Throttle Shaft      |
| 4—Washer                    | 11—Swivel              |
| 5—Push-Pull Cable           | 12—Cap Screws          |
| 6—Speed Control Arm         | 13—Throttle Stop       |
| 7—Fast Idle Adjusting Screw |                        |

Fig. 56-Adjusting Engine Speeds

1 - Connect a spring scale to the throttle lever (1) just below the knob. Turn the special nut (2) until 7 to 9 lbs. force is needed to move the lever.

2 - Remove the cotter pin (3), washer (4), and push-pull cable (5) from the speed control arm (6).

3 - Turn the speed control arm to the fast idle position.

4 - Turn the fast idle adjusting screw (7) until the engine runs at  $2650 \pm 20$  rpm.

5 - Install the push-pull cable.

6 - Remove the clevis clip (8). Push the throttle lever as far forward as it will go.

7 - Pull the push-pull cable to the preload position. To get to this position, the throttle shaft lever (9) turns 1/4 in. more after the throttle shaft (10) stops. Turn the swivel (11) until the swivel slides into the hole in the throttle lever. Install the clevis clip.

8 - Pull the throttle lever as far back as it will go. Slow idle must be  $800 \pm 20$  rpm. If not, turn the slow idle adjustment screw (on top of the governor housing cover) until the engine runs at this speed.

9 - Loosen the two throttle stop cap screws (12).

10 - Move the throttle lever until the engine runs at 2200 rpm. Slide the throttle stop (13) against the lever.

11 - Tighten the throttle stop cap screws.

Gauges checked	Yes	No
Engine speeds checked	Yes	No
Engine speeds adjusted	Yes	No

This as a preview PDF file from [best-manuals.com](https://best-manuals.com)



Download full PDF manual at [best-manuals.com](https://best-manuals.com)