

SERVICE MANUAL

Wheel Loaders LW270



NEW HOLLAND
CONSTRUCTION

PROPRIETARY NOTICE

The contents of this manual are proprietary data of New Holland Construction. Reproduction or use of any part for other than the operation and maintenance of New Holland Construction equipment is permissible only if expressly authorized in writing by New Holland Construction. Additional copies may be obtained from your New Holland Construction Dealer. Address requests for copies to your Dealer and refer to the publication number appearing on the bottom of the manual cover.

COMPANY POLICY

Company policy, which is one of continuous improvement, reserves the right to change prices and to make changes in design and specification at any time without notice and without obligation to modify units previously built.

All data given in this book is subject to production variations. Dimensions and weights are approximate only and the illustrations do not necessarily show machines in standard condition. For exact information about any particular machine please consult your New Holland Construction Dealer.

PARTS AND ACCESSORIES

Genuine parts and accessories have been specifically designed for these machines. We would like to point out that “non-genuine” parts and accessories have NOT been examined and released by the Company. The installation and or use of such products could have negative effects upon the design characteristics of your machine and thereby affect its safety. The company is not liable for any damage caused by the use of “non-genuine” parts and accessories.

MODEL CODES

The range of machines listed may not be available in all countries or markets therefore, for the latest information consult your local New Holland Construction Dealer.

MODEL

LW270

ENGINE TYPE - H.P.

CUMMINS MIIC 270 H.P.

OWNER ASSISTANCE

We at New Holland and your New Holland dealer want you to be completely satisfied with your investment. Normally any problems with your equipment will be handled by your dealer's Service Department. Sometimes, however, misunderstandings can occur. If your problem has not been handled to your satisfaction, we suggest the following.

1. Contact the owner or General Manager of the dealership, explain the problem, and request assistance. When additional assistance is needed, your dealer has direct access to our office.

2. If you cannot obtain satisfaction by doing this, contact the New Holland Construction office and provide them with:

- Your name, address, and telephone number
 - Machine model and serial number
 - Dealership name and address
 - Machine purchase date and amount of use
 - Nature of problem

NEW HOLLAND CONSTRUCTION

245 E North Ave

Carol Stream, IL 60188

Ph # (630) 260-4000

When contacting New Holland, be aware that your problem will likely be resolved in the dealership using the dealer's facilities, equipment, and personnel. So it is important that your initial contact be with the dealer.

SPARE PARTS

To maintain operating efficiency, use NEW HOLLAND original spare parts. When ordering parts, give the following information:

- Machine model
- Machine and engine serial numbers
- Part number from the Parts Catalog

TO THE OWNER:

The warranty coverage that is extended to your machine is explained in the Warranty and Limitation of Liability form. Your dealer will provide you with a copy of the warranty and retain a copy which you have signed. After you read the warranty, ask your dealer to explain any points that you may not understand.

The machine was designed to power and propel itself. It is intended to move material in the normal and customary applications.

Do not modify or alter or permit anyone else to modify or alter this machine or any of its components mechanical function with first consulting an authorized New Holland Construction dealer. If you have any questions regarding machine modifications, contact New Holland Construction, 245 E. North Ave., Carol Stream, IL 60188.

Your safety and the safety of those around you depend upon the care and good judgment you use while operating this equipment. Read the safety precautions carefully.

After you have operated the machine for 50 hours, take your machine and this manual to your selling dealer. He will perform the factory recommended 50-hour service. You will be responsible for the cost of lubricants, fluids, filters and other items replaced as part of normal maintenance. Prior to taking the machine to your selling dealer for service, it is recommended that you contact them to determine any other charges for which you may be responsible.

All data given in this book is subject to product variations. Dimensions and weights are approximate only and the illustrations do not necessarily show machines in standard condition. For exact information about any particular machine, please consult your New Holland Construction dealer.



CAUTION: THIS SYMBOL IS USED THROUGHOUT THIS BOOK WHENEVER PERSONAL SAFETY IS INVOLVED. TAKE TIME TO READ AND FOLLOW THE INSTRUCTIONS. BE CAREFUL!

CAUTION: PICTURES IN THIS MANUAL MAY SHOW PROTECTIVE SHIELDING OPEN OR REMOVED TO BETTER ILLUSTRATE A PARTICULAR FEATURE OR ADJUSTMENT.

BE CERTAIN, HOWEVER, TO CLOSE OR REPLACE ALL SHIELDING BEFORE OPERATING THE MACHINE.

IMPROVEMENTS

New Holland Construction is continually striving to improve its products. We reserve the right to make improvements or changes when it becomes practical and possible to do so, without incurring any obligation to make changes or additions to the equipment sold previously.

PRECAUTIONARY STATEMENTS

PERSONAL SAFETY

Throughout this manual and on machine decals, you will find precautionary statements (“CAUTION”, “WARNING”, and “DANGER”) followed by specific instructions. These precautions are intended for the personal safety of you and those working with you. Please take the time to read them.



CAUTION: THE WORD “CAUTION” IS USED WHERE A SAFE BEHAVIORAL PRACTICE ACCORDING TO OPERATING AND MAINTENANCE INSTRUCTIONS AND COMMON SAFETY PRACTICES WILL PROTECT THE OPERATOR AND OTHERS FROM ACCIDENT INVOLVEMENT.



WARNING: THE WORD WARNING DENOTES A POTENTIAL OR HIDDEN HAZARD WHICH HAS A POTENTIAL FOR SERIOUS INJURY. IT IS USED TO WARN OPERATORS AND OTHERS TO EXERCISE EVERY APPROPRIATE MEANS TO AVOID A SURPRISE INVOLVEMENT WITH MACHINERY.



DANGER: THE WORD “DANGER” DENOTES A FORBIDDEN PRACTICE IN CONNECTION WITH A SERIOUS HAZARD.

FAILURE TO FOLLOW THE “CAUTION”, “WARNING”, “DANGER”, AND “STOP” INSTRUCTIONS MAY RESULT IN SERIOUS BODILY INJURY OR DEATH.

MACHINE SAFETY

Additional precautionary statements (“ATTENTION” and “IMPORTANT”) are followed by specific instructions. These statements are intended for machine safety.

ATTENTION: The word “ATTENTION” is used to warn the operator of potential machine damage if a certain procedure is not followed.

IMPORTANT: The word “IMPORTANT” is used to inform the reader of something he needs to know to prevent minor machine damage if a certain procedure is not followed.

SAFETY RULES

This symbol is your safety alert sign. It means **ATTENTION! BECOME ALERT! YOUR SAFETY IS INVOLVED!**

Read and heed all safety instruction carrying the signal words **WARNING** and **DANGER**.

STUDY THE OPERATION AND MAINTENANCE INSTRUCTION MANUAL THOROUGHLY BEFORE STARTING, OPERATING, MAINTAINING, FUELING OR SERVICING THIS MACHINE.



MOST ACCIDENTS ARE CAUSED BY FAILURE OF SOME INDIVIDUAL TO FOLLOW SIMPLE AND FUNDAMENTAL SAFETY RULES OR PRECAUTION. FOR THIS REASON MOST ACCIDENTS CAN BE PREVENTED BY RECOGNIZING THE REAL CAUSE AND DOING SOMETHING ABOUT IT BEFORE ACCIDENT OCCURS. REGARDLESS OF THE CARE USED IN THE DESIGN AND CONSTRUCTION OF ANY TYPE OF EQUIPMENT THERE ARE MANY CONDITIONS THAT CAN'T BE COMPLETELY SAFEGUARDED AGAINST WITHOUT INTERFERING WITH REASONABLE ACCESSIBILITY AND EFFICIENT OPERATION.



CALIFORNIA

PROPOSITION 65 WARNING

Diesel engine exhaust and some of its constituents are known to the State of California to cause cancer, birth defects, and other reproductive harm.



SAFETY PRECAUTION INFORMATION

UNSAFE OPERATING PRACTICES AND IMPROPER USE OF THE MACHINE AND ITS ATTACHMENTS ON THE PART OF THE OPERATOR OR SERVICE TECHNICIAN CAN RESULT IN INJURIES. OBSERVE THE FOLLOWING SAFETY PRECAUTIONS AT ALL TIMES:

- 1. FOR SERVICING, THE MACHINE SHOULD BE ON LEVEL TERRAIN, ENGINE STOPPED WITH THE WHEELS BLOCKED OR THE ENTIRE MACHINE SOLIDLY SUPPORTED WITH THE WHEELS OFF THE GROUND BEFORE SERVICING ANY COMPONENT OF THE DRIVETRAIN.**
- 2. FOR SERVICING UNDER THE MOVABLE EQUIPMENT, SUCH AS OPERATOR'S SEAT, ENGINE HOODS, ETC. MOVE THE EQUIPMENT ASSEMBLY TO THE LATCHED POSITION AND SECURELY LATCH.**
- 3. DO NOT OPERATE THE MACHINE UNLESS ALL MOVABLE EQUIPMENT IS LATCHED IN THE OPERATE POSITION.**
- 4. DO NOT SERVICE THE MACHINE WITH A RAISED HYDRAULIC EQUIPMENT UNLESS THE HYDRAULIC EQUIPMENT IS RESTING ON LOCK PINS OR CYLINDER LOCKING TOOLS OR FIXTURES.**
- 5. DO NOT SERVICE THE MACHINE WITH THE ENGINE RUNNING UNLESS THE MACHINE IS PROPERLY AND SECURELY SUPPORTED WITH ALL FOUR WHEELS OFF THE GROUND.**
- 6. USE CAUTION WHEN SERVICING THE UNIT AROUND MOVING PARTS.**
- 7. DO NOT TILT ANY MOVABLE EQUIPMENT WITHOUT PROPER INSTRUCTION.**
- 8. DO NOT TILT ANY MOVABLE EQUIPMENT WITHOUT USING THE PROPER TOOLS.**
- 9. REINSTALL ALL SHIELDS REMOVED FOR SERVICE.**
- 10. NEVER LOOSEN ANY HYDRAULIC CONNECTIONS BEFORE RELIEVING THE PRESSURE IN THE HYDRAULIC SYSTEM.**
- 11. WEAR EYE PROTECTION SUCH AS GOGGLES, ETC.**
- 12. WEAR EAR PROTECTION SUCH AS EARPLUGS, ETC. WHEN YOU FEEL THE NOISE LEVEL IS UNCOMFORTABLE.**
- 13. IF ANY SERVICING OR ADJUSTMENTS REQUIRE THE BATTERY TO BE DISCONNECTED, DISCONNECT THE (-) NEGATIVE GROUND CABLE.**
- 14. WHEN SERVICING ELECTRICAL COMPONENTS, DISCONNECT THE (-) NEGATIVE GROUND CABLE.**
- 15. IF AN ELECTRONIC EQUIPMENT REQUIRES REMOVAL FROM THE DASH AREA OR THE MACHINE, DISCONNECT THE (-) NEGATIVE GROUND BATTERY CABLE. THIS WILL SHUT OFF POWER TO THE ELECTRICAL SYSTEM AND PREVENT DAMAGE TO THE ELECTRICAL SYSTEM.**
- 16. IF WELDING IS REQUIRED ON THE MACHINE, DISCONNECT THE (-) NEGATIVE GROUND CABLE. FAILURE TO DISCONNECT THE BATTERY MAY RESULT IN DAMAGE TO THE ELECTRICAL SYSTEM, MONITORING SYSTEM AND/OR OTHER ELECTRICAL COMPONENTS.**
- 17. IF WELDING IS REQUIRED ON AN ATTACHMENT, REMOVE THE ATTACHMENT FROM THE MACHINE.**

18. GIVE COMPLETE AND UNDIVIDED ATTENTION TO THE JOB AT HAND SO THAT COMPLETE CONTROL OF THE MACHINE IS MAINTAINED AT ALL TIMES.
19. DRIVE SLOWLY OVER ROUGH GROUND AND ON SLOPES; KEEP ALERT FOR HOLES, DITCHES AND OTHER IRREGULARITIES THAT MAY CAUSE THE MACHINE TO OVERTURN.
20. AVOID STEEP HILLSIDE OPERATION WHICH COULD CAUSE THE MACHINE TO OVERTURN.
21. NEVER TRANSPORT A LOADED BUCKET AT FULL HEIGHT. OPERATE THE MACHINE WITH THE LOAD AS LOW AS POSSIBLE UNTIL IT BECOMES NECESSARY TO RAISE THE BOOM TO DISCHARGE THE LOAD INTO A TRUCK, CONTAINER, ETC.
22. REDUCE SPEED WHEN TURNING SO THERE IS NO DANGER OF OVERTURNING.
23. NEVER DRIVE UP OR BACK UP A HILL OR INCLINE WITH A RAISED BOOM OR THE MACHINE COULD OVERTURN.
24. ALWAYS LOOK BEHIND YOU BEFORE BACKING UP THE MACHINE.
25. MAINTAIN PROPER FLUID LEVELS TO PREVENT LOSS OF POWER, BRAKING OR OTHER FUNCTIONS.
26. DO NOT ALLOW PASSENGERS TO RIDE ON THE MACHINE AT ANY TIME.
27. DO NOT ALLOW CHILDREN TO OPERATE THE MACHINE OR RIDE ON THE MACHINE AT ANY TIME.
28. DO NOT ALLOW ANYONE TO OPERATE OR SERVICE THE MACHINE WITHOUT PROPER INSTRUCTION.
29. OSHA REQUIRES THAT ALL OPERATORS BE INSTRUCTED ON THE PROPER OPERATION OF THE MACHINE BEFORE THEY OPERATE THE UNIT.
30. DO NOT OPERATE THE LOADER IN ANY POSITION OTHER THAN WHILE IN THE OPERATOR'S SEAT WITH THE SEAT BELT SECURELY FASTENED.
31. BEFORE STARTING THE ENGINE, BE SURE THAT ALL OPERATING CONTROLS ARE IN NEUTRAL AND THE PARKING BRAKE IS ENGAGED.
32. NEVER OPERATE THE ENGINE IN A CLOSED BUILDING WITHOUT ADEQUATE VENTILATION.
33. REFUEL THE MACHINE OUTDOORS WITH THE ENGINE SHUT OFF. REPLACE THE FUEL CAP SECURELY. USE AN APPROVED FUEL CONTAINER. DO NOT SMOKE WHEN HANDLING FUEL. AVOID SPILLING FUEL.
34. AFTER OPERATING THE ENGINE, NEVER TOUCH THE MUFFLER, EXHAUST PIPE, ENGINE OR RADIATOR UNTIL THEY HAVE HAD TIME TO COOL.
35. DRESS APPROPRIATELY – WEAR RELATIVELY TIGHT-FITTING CLOTHING WHEN OPERATING OR SERVICING THE MACHINE. LOOSE OR TORN CLOTHING CAN CATCH IN MOVING PARTS OR CONTROLS.
36. BEFORE SERVICING THE MACHINE, OR ANY OF ITS ATTACHED EQUIPMENT, BE SURE THAT THE ATTACHMENTS ARE LOWERED TO THE GROUND OR ARE SUPPORTED.
37. DO NOT WORK UNDER OVERHANGS, ELECTRIC WIRES, OR WHERE THERE IS DANGER OF A SLIDE.

38. WEAR AN APPROVED SAFETY HAT WHEN OPERATING THE MACHINE AND WHILE IN ANY WORK AREA.
39. WHEN DRIVING THE MACHINE ON A ROAD OR HIGHWAY, USE WARNING LIGHTS OR WARNING DEVICES AS MAY BE REQUIRED BY LOCAL OR STATE GOVERNMENT REGULATIONS. HEADLIGHTS, WARNING LIGHTS AND SMV SIGNS ARE AVAILABLE THROUGH YOUR NEW HOLLAND DEALER.
40. KEEP THE MACHINE CLEAN. DO NOT ALLOW TRASH, DEBRIS OR OTHER ARTICLES TO ACCUMULATE IN THE CAB, FLOOR OR FOOT CONTROL PEDAL AREA THAT MAY HINDER SAFE MACHINE OPERATION.
41. NEVER OPERATE THE MACHINE WITH ANY OF THE SHIELDING REMOVED.
42. NEVER OPERATE THE MACHINE WITHOUT WINDOWS AND/OR SCREENS IN PLACE.
43. NEVER EXTEND ANY PART OF THE BODY OUTSIDE OF THE OPERATOR'S AREA.
44. ALWAYS PROPERLY TIE DOWN THE MACHINE TO A TRUCK OR TRAILER BEFORE TRANSPORT.
45. MAKE SURE ALL BYSTANDERS ARE AT A SAFE DISTANCE AWAY FROM THE MACHINE BEFORE STARTING THE ENGINE.
46. DO NOT ALLOW ANYONE NEAR THE MACHINE WHILE THE ENGINE IS RUNNING AND THE MACHINE IS OPERATIONAL.
47. WHEN USING THE MACHINE TO CRANE OBJECTS, DO NOT ALLOW ANYONE TO RIDE ON OBJECTS BEING CRANED.
48. DO NOT USE THE MACHINE AS A WORK PLATFORM FOR SUPPORTING MATERIALS.
49. DO NOT LIFT PERSONNEL OR ALLOW PERSONNEL TO WORK WHILE STANDING IN THE BUCKET OR ON OTHER ATTACHMENTS. THIS IS NOT A MAN-LIFT.

OSHA REQUIREMENTS NOW MAKE IT THE EMPLOYER'S RESPONSIBILITY TO FULLY INSTRUCT EACH OPERATOR IN THE PROPER AND SAFE OPERATION OF ALL OPERATIVE EQUIPMENT. BOTH EMPLOYER AND EMPLOYEE SHOULD THOROUGHLY FAMILIARIZE THEMSELVES WITH THE MACHINE OPERATION.



CAUTION!

SOME PICTURES IN THIS MANUAL SHOW SAFETY SHIELDS REMOVED OR OPEN TO SHOW PARTS BEING SERVICED OR FOR CLARITY. ALL SHIELDS SHOULD BE CLOSED OR REPLACED PRIOR TO OPERATING THE MACHINE.

DANGER!

FASTEN SEAT BELT

BEFORE STARTING ENGINE!

PAGE LEFT INTENTIONALLY BLANK

S U M M A R Y

SAFETY RULES	pag. 1
SPECIFICATIONS	pag. 8
FLUIDS AND CAPACITY TABLE	pag. 10
UNITS OF MEASURE USED IN THE MANUAL	pag. 11
TIGHTENING TORQUES	pag. 12

ENGINE.....	Section 1
TRANSMISSION.....	Section 2
BRAKING SYSTEM.....	Section 3
STEERING SYSTEM	Section 4
BUCKET BOOM AND FRAME	Section 5
ATTACHMENT HYDRAULIC SYSTEM.....	Section 6
ELECTRICAL SYSTEM	Section 7
CAB	Section 8

PAGE LEFT INTENTIONALLY BLANK

SAFETY RULES

GENERALITIES

Read this Manual carefully before starting, operating, maintaining, fuelling or servicing the machine.

Read and comply with all safety precautions before any work.

Do not allow unauthorised personnel to operate or service this machine.

Do not wear rings, wrist watches, jewellery, loose or hanging garments, such as ties, torn clothing, scarves, unbuttoned or unzipped jackets that can get caught in moving parts. Wear certified safety clothes such as: hard hat, no-slip footwear, heavy gloves, ear protection, safety glasses, reflector vests, respirators. Ask your employer about specific safety equipment requirements.

Keep the operator's compartment, step plates, grab-rails and handles clean and clear of foreign objects, oil, grease, mud or snow to minimize the danger of slipping or stumbling. Remove mud or grease from your shoes before attempting to mount or operate the machine.

Do not jump on or off the machine. Always keep both hands and one foot, or both feet and one hand in contact with steps and grab rails.

Do not use controls or hoses as hand holds when climbing on or off the machine. Hoses and controls are movable parts and do not provide solid support. Besides, controls may be inadvertently moved and cause unexpected movement of the machine or its attachments.

Never operate the machine or its attachments from any position other than sitting in the driver's seat.

Keep head, body, limbs, hands and feet inside the operator's compartment at all times to reduce exposure to external hazards .

Be careful of possible slippery conditions of the steps and hand rails as well as of the ground around the machine.

Do not leave the machine until it has come to a complete stop.

Check the seat safety belt at least twice per year and replace it if it shows signs of wear, fraying or other weakness that could lead to failure.

STARTING

NEVER START OR OPERATE A FAILED MACHINE. Before operating the machine, always ensure that any unsafe condition has been satisfactorily corrected.

Check brakes, steering and attachment controls before moving off. Report any malfunctioning part or system to the maintenance managers for proper action.

Ensure all protective guards and panels as well as all safety devices provided are in place and in good operating condition.

Ensure that nobody is in the machine operating range before moving off or operating the attachment. **WALK COMPLETELY AROUND** the machine before mounting.

Sound the horn.

Before starting machine, check, adjust and lock the driver's seat for maximum comfort and control of the machine.

Fasten your seat belts(when fitted).

Obey all flag signals and signs.

Due to the presence of flammable fluids on the machine, never check or fill fuel tanks or accumulator batteries near fires, open flames, or sparks.

REMEMBER THAT SPECIAL STARTING FLUIDS ARE FLAMMABLE. Scrupulously follow recommendations printed on the containers and in this Manual.

DO NOT PUNCTURE OR BURN CONTAINERS.

Containers must be stored in fresh, well ventilated places and out of the reach of unauthorised personnel. Strictly follow the instructions provided by the Manufacturer.

Never use these products near fires, open flames, or sparks.

OPERATING

Check wheel and rim retainers before each working shift. If necessary, tighten to the torque specified.

Do not run the engine of this machine in closed buildings without proper ventilation capable to remove harmful exhaust gases.

Roll Over Protective Structures (ROPS) are required on wheel or crawler loaders, dozers, or graders. **NEVER OPERATE** the machine if such protective structure is removed.

Keep the operator's compartment free of foreign objects, especially if not firmly secured. Never use the machine to transport objects, unless proper securing points are provided.

DO NOT CARRY RIDERS ON THE MACHINE

Study and familiarize with escape routes alternate to normal exit routes.

According to law provisions, seat belts must be fitted with Roll Over Protection Structures or cabs. Keep safety belts fastened during operation.

For your personal safety, do not climb on or off the machine while it is in motion.

Make sure that bystanders are clear of the machine operating range before starting the engine and operating the attachment. Sound the horn. Obey all indications provided by flags, signs and signals.

DO NOT COAST OR FREEWHEEL down hills. Engage the most suitable gear speed to keep the machine under control.

SAFETY RULES

Do not operate the machine if you are extremely tired or feel ill. Be especially careful towards the end of the working shift.

Do not operate a machine with misadjusted brakes.

Operate the machine at low speed which can ensure complete control at all times.

Travel slowly over very rough terrain, slopes or near drop-offs, in congested areas or on frozen or slippery surfaces.

When backing, always look to where the machine is to be moved. Be alert of the position of personnel. Should someone enter the work area, STOP THE MACHINE.

Maintain a safe distance from other machines or obstacles to ensure required visibility conditions. Give way to loaded machines.

Maintain a clear vision of the surroundings of the travel or work area at all times. Keep cab windows clean and repaired.

When machines are operating in tandem, the pusher (rear) must be equipped with the appropriate deflectors to protect the front unit driver against the air stream coming from the blower fan.

When pulling or towing through a cable or chain, do not start suddenly at full throttle. Take-up slack carefully.

Carefully inspect the towing items for flaws before proceeding.

Avoid kinking or twisting chains or cables. Do not pull through a kinked chain or cable as the high stresses existing in this condition may induce failures. Always wear heavy gloves when handling chains or cables.

Chains and cables should be securely anchored. Anchor points should be strong enough to withstand the expected load. Keep anyone clear of anchor points and cables or chains.

DO NOT PULL UNLESS THE OPERATOR'S COMPARTMENTS OF THE MACHINES INVOLVED ARE PROPERLY PROTECTED AGAINST POSSIBLE BACKLASH IN CASE OF CABLE OR CHAIN FAILURE OR DETACHMENT.

Be alert of soft ground conditions close to newly constructed walls. The fill material and machine weight may cause the wall to collapse.

In darkness, check area of operation carefully before moving in with the machine. Use all lights provided. Do not move into low visibility areas.

If the engine tends to stall for whatever reason under load or at idle, immediately report this problem to the maintenance managers for proper action. Do not operate the machine until this condition has been corrected.

On machines fitted with suction radiator fans, regularly check the engine exhaust system for leaks, as exhaust fumes expelled towards the operator are toxic.

Operators must know thoroughly the performances of the machine they are driving. When working on slopes or near sudden level drops in the terrain, avoid areas where ground

is loose or soft since overturn or loss of machine control could result.

If noise level is high and continuously exceeds 90 dBA over eight hours at the operator's ear, wear approved ear protection in compliance with local regulations.

Where counterweights are provided, do not operate the machine if they have been removed.

When transporting a loaded bucket, keep it as rolled-back and low as possible for maximum visibility, stability and safety of the machine. Ground speed should be adequate to the load and ground conditions.

The load must always be properly arranged in the bucket; move with extreme care when transporting oversize loads.

Use only the type of bucket recommended for the machine and the materials to be handled. Follow the recommendations concerning loading capacity, arrangement of the materials, characteristics of the ground and job to be performed.

Do not lift and move loads overhead where any personnel are standing or working, nor downhill when working crosswise on slopes. In this case, the bucket should be unloaded on the uphill side, whenever possible.

Start and stop the machine carefully when the bucket is full. Do not move off without first reducing engine speed.

Overtaking manoeuvres should be performed only when absolutely necessary and unavoidable. Beware possible uneven terrains, poor visibility, presence of other machinery or personnel out of sight.

Operate the machine at a speed adequate to the working site conditions and in any case slow enough to ensure complete control at all times.

Check instruments at start-up and frequently during operation. Stop the machine immediately should any malfunction be signalled.

Never use the bucket as a man lift or to carry riders.

Never use the machine as a work platform or scaffolding, nor for other improper use (such as pushing railway cars, trucks or other machines).

Pay attention to people within the machine operating range. Load trucks from the driver's side whenever possible.

Prior to operating the machine, check for obstacles and/or problems you will encounter, such as narrow streets, overhead doors, cables, piping, as well as ground, bridges, paving and ramps bearing load limitations.

In case of road transfers, find out beforehand what conditions are likely to be encountered, such as size restrictions, heavy traffic, paving type, etc. Beware fog, smoke or dust that obscure visibility.

When crossing gullies or ditches, move at an angle with reduced speed after ensuring ground conditions will permit as a traverse. Always inspect the working area to identify potential risks

SAFETY RULES

such as: inclines, overhangs, trees, demolition rubble, fires, ravines, steep slopes, rough terrain, ditches, crowns, ridge trenches, heavy traffic, crowded parking and service areas, closed ambients. In such conditions, proceed with extreme care.

When ever possible, avoid going over obstacles such as very rough terrain, rocks, logs, steps, ditches, railroad tracks. When obstructions must be crossed, do so with extreme care and at an angle, if possible. Slow down and select a lower gear. Ease up to the break-over point, pass the balance point slowly and ease down the other side.

In steep down-hill operation, do not allow the engine to over-speed. Select the proper gear before starting down grade.

Avoid crosswise hill travel, whenever possible. Drive up and down the slope. Should the machine start slipping sideways when going uphill, steer and turn machine front immediately downhill.

The gradient you may attempt to overcome is limited by factors such as ground conditions, load being handled, machine type and speed, and visibility.

There is no substitute for good judgement and experience when working on slopes.

Avoid operating the attachment too close to an overhang or high wall, either above or below the machine. Beware of caving edges, falling objects and landslips. Remember that such hazards are likely to be concealed by bushes, undergrowth and such.

When pushing- trees over, the machine must be equipped with proper overhead guards. Never drive a machine up the roots, particularly while the tree is being felled. Use extreme care when pushing any tree over with dead branches.

Avoid bushes, logs and rocks.

NEVER DRIVE OVER THEM, or over any other surface irregularities that discontinue adherence or traction with the ground, especially near slopes or drop-offs.

Be alert to avoid changes in traction conditions that could cause loss of control. AVOID driving on ice or frozen ground when working on steep slopes or near drop-offs.

Working in virgin rough terrains is characterized by the presence of all the perils and risks listed above. In these conditions, it is emphasized the danger represented by large tree limbs (possibly falling on the machine), large roots (which may act as a leverage under the machine when up-rooted and cause the unit to overturn), etc.

STOPPING

When the machine is to be stopped for whatever reason, do so following the instructions given in chapters "Stopping the machine" and "Shutting off the engine" in the Operation and Maintenance Instruction Manual.

Always remember to move the gearshift lever to the neutral position and engage the control lever lock for safety purposes.

Apply the parking brake (if fitted).

NEVER LEAVE THE MACHINE UNATTENDED with the engine running.

Prior to leaving the operator's seat, and after making sure that all personnel are clear of the machine, always slowly lower the attachment until resting it safely to the ground

Park the machine in a non-operating and no-traffic area. Park on firm level ground. If this is not possible, position the machine at a right angle to the slope, making sure there is no danger of uncontrolled sliding. Apply the parking brake.

If parking in traffic lanes cannot be avoided, provide appropriate flags, barriers, flares and signals as required to adequately warn the oncoming drivers.

Keep head, body, limbs, hands and feet clear of the dozer, arms, bucket or ripper when raised.

Always switch off the battery isolator switch before servicing the machine in whatever manner (i.e., cleaning, repairing, maintaining, etc.). Do the same when the machine is to remain parked for prolonged periods of time to avoid accidental or unauthorized starting.

Never lower the attachments without sitting in the operator's seat. Sound the horn. Make sure that no personnel is within the machine operating range. Lower the attachment slowly. DO NOT USE FLOAT POSITION in case of hydraulic controls.

Securely block the machine and lock it every time you leave it unattended. Return keys to authorized security. Perform all necessary operations as detailed in the Operation and Maintenance Instruction Manual. Apply the parking brake (if fitted) every time you leave the machine.

MAINTENANCE

GENERALITIES

Before operating or performing any intervention on the machine:

- carefully read all the norms contained in this Manual;
- read and observe all safety plates and instructions located on the machine.

Do not allow unauthorized personnel to service the machine. Do not carry out any maintenance work without prior authorization. Follow all recommended maintenance and service procedures.

Keep the operator's compartment free of loose objects that are not properly secured.

Do not wear rings, wrist watches, jewellery, loose or hanging garments, such as ties, torn clothing, scarves,

SAFETY RULES

unbuttoned or unzipped jackets that can get caught in moving parts. Wear certified safety clothes such as: hard hat, no-slip footwear, heavy gloves, ear protection, safety glasses, reflector vests, respirators. Ask your employer about specific safety equipment requirements.

Never service the machine with someone sitting in the driver's seat, unless this person is an authorized operator assisting in the maintenance being carried out.

Keep the operator's compartment, step plates, grab rails and handles clear of foreign objects, oil, grease, mud or snow to minimize the danger of slipping or stumbling.

Clean mud or grease from your shoes before climbing on the machine or driving it.

Never attempt to operate the machine or its attachments from any position other than sitting in the operator's seat.

Never stand under the boom.

Should it be necessary to move the attachment through the hydraulic controls for maintenance purposes, remember that this should be done while sitting in the operator's seat. Before starting the machine or moving its attachment, apply the brakes, sound the horn and call that you are about to manoeuvre. Raise the attachment slowly.

Always lock the machine arms or any other parts that must be lifted for maintenance purposes using adequate external means. Do not allow any personnel to pass near or even below a raised yet unlocked attachment. If you are not absolutely sure about your safety, do not stay under a raised attachment, even if it is locked.

Do not place body, limbs, or fingers near articulated cutting edges of uncontrolled machine parts or deprived of the necessary guards, unless they are suitably and safely locked.

Never perform any work on the machine with the engine running, except when this is specifically required. Do not wear loose clothing, jewelry or such near moving parts.

When service or maintenance require access to areas that cannot be reached from the ground, use a ladder or step platform conforming to regulations in force. If such means are not available, use machine grab rails and steps. Always perform all service or maintenance work with the greatest care and attention.

Shop and/or field service platforms or ladders should be manufactured in accordance with safety regulations in force.

Disconnect batteries and label all controls to warn that service work is in progress. Block the machine and all attachments to be raised.

Do not check or fill fuel tanks, batteries and accumulators, nor use the starting liquid if you are smoking or near open flames. These fluids are flammable!

BRAKES ARE INOPERATIVE when manually released for servicing. Provisions must be made to maintain control of the machine using suitable blocks or other means.

The fuel filler pipe nozzle must be constantly kept in contact with the filler neck. Keep this contact from the beginning to the end of the fuelling operation to avoid possible generation of sparks due to static electricity.

Tow the machine only from the attaching points provided. Use care in making connections and ensure pins and/or bolt are firmly secured before pulling. Stay clear of draw-bars, cables or chains under load.

To move a failed machine, use a trailer or a low platform truck, if available. In case towing is needed, use all necessary signals required by local regulations, and follow directions provided in this Manual.

Load/unload the machine from transporter on firm level ground providing safe support to the wheels of the truck or trailer. Use strong access ramps, with adequate height and angle. Keep the loading platform free of mud, oil or slippery materials.

Tie the machine securely to the platform of the truck or trailer and opportunely wedge machine wheels or tracks as required.

Never align holes or slots using your fingers; always use appropriate aligning tools.

Remove all sharp edges and burrs from re-worked parts.

Use only approved and effectively grounded auxiliary power sources for heaters, battery chargers, pumps and similar equipment to reduce electrical shock hazard.

Lift and handle heavy components using hoisting devices of appropriate capacity. Ensure the sling has been correctly applied. Use lifting eyes if provided. Pay attention to personnel.

Never pour gasoline or diesel fuel into open, wide and low containers. Never use gasoline, solvents or other flammable fluids to clean parts. Use proprietary certified non-flammable, non-toxic solvents only.

When using compressed air to clean parts, wear safety glasses with side shields. Limit pressure to maximum 2 bars (29.00 psi), in accordance with local safety regulations in force.

Do not run the engine in closed buildings without proper ventilation capable to remove lethal fumes.

Do not smoke, use open flames or produce sparks nearby while refuelling the unit or handling highly flammable materials.

Do not use any flame as a light source during maintenance work or to look for leaks anywhere on the machine.

Make sure that all tools provided are in good condition at all times. **NEVER USE** tools with mushroomed or damaged heads. Always wear eye protections.

Move with extreme care when working under the machine, its attachments, and even on or near them. Always wear protective safety equipment as required, such as hard hat, goggles, safety shoes, and ear plugs.

SAFETY RULES

In case tests during which the engine should be kept running, a qualified operator must sit in the driver's seat with the mechanic in sight at all times. Place the transmission in neutral, apply and lock the brakes. **KEEP HANDS OFF MOVING PARTS.**

In case of field service, move machine to level ground, if possible, and block it. If work on an incline cannot be avoided, block the machine and its attachments securely. Move machine to level ground as soon as possible.

Do not trust worn or kinked chains and cables. Never use them for lifting or pulling. Always wear heavy gloves to handle chains or cables.

Be sure chains and cables are firmly fastened and that anchor points are strong enough to withstand the expected load. Nobody should stay near the anchor points, cables or chains. **DO NOT PULL OR TOW UNLESS THE OPERATOR'S COMPARTMENTS OF THE MACHINES INVOLVED ARE FITTED WITH THE PROPER GUARDS AGAINST BACKLASH IN CASE OF CABLE OR CHAIN FAILURE OR DETACHMENT.**

Keep the area where maintenance is carried out **CLEAN** and **DRY** at all times. Clean immediately all water and oil spillages.

Do not pile up oily or greasy rags as they represent a major fire hazard. Always store them in closed metal containers.

Before starting the machine or its attachment, check, adjust and lock the operator's seat. Also ensure that no personnel is within the machine operating range. Sound the horn.

Rust inhibitors are volatile and flammable. Use them only in well ventilated areas. Keep open flames away - **DO NOT SMOKE** - Store containers in a cool well ventilated place where they could not be reached by unauthorized personnel.

Do not carry loose objects in your pockets that might fall unnoticed into open compartments.

Wear safety glasses with side shields, hard hat, safety shoes, heavy gloves when metal particles or similar may be ejected and hit you.

Wear appropriate protective equipment such as dark safety glasses, hard hat, protective clothing, special gloves and footwear while welding. Nearby persons should also wear dark safety glasses even if they are not welding. **DO NOT LOOK THE WELDING ARC WITHOUT PROPER EYE PROTECTION.**

Become acquainted with all your jacking equipment and its capacity. Remember that the jacking point on the machine should be appropriate for the load applied. Also, be sure the support area of the jack at the machine and on the ground is appropriate and stable.

Any load supported by a jack represents a possible hazard. Always transfer the load onto appropriate support means according to local or national safety requirements before proceeding with service or maintenance work.

Metal cables get frayed after prolonged use. Always wear appropriate protections (heavy gloves, goggles, etc.) while handling them.

Handle all parts carefully. Keep hands and fingers away from gaps, gears, and similar. Always use and wear the appropriate protections.

Water can build up in pneumatic systems from condensate moisture due to changes in atmospheric conditions. If necessary, drain such deposits following instructions.

Before carrying out any maintenance work or service, lock the machine articulated frame modules using the appropriate safety device. Remember to remove and store it properly at the end of work.

If the machine is equipped with hydraulic brakes, make sure that the reservoir is always filled up to the correct level.

Always block all wheels, front and rear, before bleeding the braking system or disconnecting control hoses and/or cylinders.

STARTING

Do not run the engine in closed buildings without proper ventilation capable to remove lethal exhaust fumes.

Do not place head, body, limbs, feet, hands or fingers near rotating fans or belts.

Be especially careful near blower fans.

REMEMBER THAT THE STARTING FLUID IS HIGHLY FLAMMABLE. Follow recommendations provided in this Manual and printed on the containers. Containers must be stored in a cool, well ventilated place out of the reach of unauthorized persons.

DO NOT PUNCTURE OR BURN CONTAINERS.

ENGINE

Loosen the radiator cap very slowly to relieve system pressure before removing it. Always top-off coolant level with the engine off.

Avoid that flammable materials could touch exhaust parts. If not possible, provide necessary protections.

Do not refuel with the engine running, especially if hot, as this increases fire hazard.

Never attempt to check or adjust fan belt tensions when the engine is running.

SAFETY RULES

Do not adjust the fuel pump when the machine is motion.
Do not lubricate the machine with the engine running.
Do not run the engine with air intakes, door or guards open.

ELECTRICAL SYSTEM

Always disconnect the batteries prior to any work on the machine or its electrical system (cleaning, repair, maintenance).

Should booster batteries be used, remember to connect ends of the booster cables in the proper manner: (+) to (+) and (-) to (-). Do not short-circuit terminals. Thoroughly follow instructions given in this Manual.

Before any intervention, make sure that the battery isolator switch is off.

BATTERY GAS IS HIGHLY FLAMMABLE. Leave the battery compartment open during recharging to improve ventilation. Never check battery charge by placing metal objects across the posts. Keep sparks or open flames away from batteries. Do not smoke near the battery to prevent explosion hazard.

Before any work, make sure that there are no fuel or electrolyte leakages. If any, correct prior to proceeding with further work. Do not recharge batteries in confined spaces. Ensure proper ventilation is provided to avoid accidental explosions due to build-up of gas released during charging.

HYDRAULIC SYSTEM

Pressure fluid escaping from a very small hole can be almost invisible and still have sufficient force to penetrate the skin. Always check any suspected pressure leaks using a piece of cardboard or wood. **DO NOT USE HANDS.** If injured by escaping fluid, obtain medical attention immediately or serious infection or reaction may develop.

Stop the engine and relieve all system pressure before removing panels, housings, caps, plugs or covers.

Always use gauges of adequate capacity (end-of-scale reading) and follow recommended procedures.

TOOLS

Always keep head, body, limbs, feet, or hands away from bucket, blade, or ripper when in the raised position. Prior to any intervention, install all safety devices according to current regulations. In case the attachment is to be operated through the machine hydraulic system for maintenance purposes, remember to do so only while sitting in the

driver's seat. Make sure that no personnel is within the machine operating range. Before operating the attachment, alert personnel by sounding the horn and by voice. Raise the attachment slowly.

Do not use the machine to transport loose objects, unless proper devices to this purpose are provided.

Clutches and brakes of this machine as well as auxiliary devices and attachments (such as drive cylinder or winch control valves) should always be properly adjusted in accordance with the instructions provided by the Manufacturer. Never perform adjustments with the engine running, except when this is specifically required by the relevant procedures.

TIRES AND WHEELS

Make sure that the tire inflation pressure corresponds to specifications issued by the Manufacturer. Regularly check inflation pressure.

Should pressure be changed, do this while staying on the tire side and at a safe distance.

Pressure checks should always be carried out with the machine unloaded and cold tires.

Never use reconditioned tire rims, since possible weldings, incorrect heat-treatments or repairs can weaken the wheels and cause damages or failures.

Do not cut, nor weld rims with inflated tires installed.

The spare tire should be inflated only enough to keep the rim components assembled. Remember that when not installed on the disc, a tire inflated to maximum pressure can **explode**.

Therefore, maximum care must be taken when handling a fully inflated tire.

Before servicing tires, block all wheels, front and rear. After jacking up the machine, block it in the raised position using suitable stands conforming to current safety regulations.

Deflate the tire before removing objects from the tire tread.

Never inflate tires with flammable gas: explosions and severe bodily injuries may result.

When starting your work shift, check for loose wheel or rim bolts and brackets and retighten to correct torque.

SAFETY RULES

DECOMMISSIONING THE MACHINE

For the decommissioning of the machine, the availability of particular tooling (hoists, hydraulic presses, containers for liquids etc.) is required as well as specific tools listed in the Repair Manuals, available from **NEW HOLLAND CONSTRUCTION Dealers**.

This has the purpose of avoiding that during disassembly operations, dangerous situations may arise both for the personnel involved and the environment.

In the machine are present:

- Fluids under pressure (hydraulic system, cooling system etc.)
- Gases (air conditioning system and accumulator, if installed)
- Mechanical devices mounted under pressure (track tensioner etc.)
- Heavy machine components (frames, blades, buckets etc.)

**WARNING**

- *The decommissioning of the machine must be performed exclusively by personnel trained, qualified and authorized to perform such operation.*
- *Start the disassembly of hydraulic components only after the same, the hydraulic oil and lubricants have fully cooled-off and after all residual pressures have been released, as described by the Repair Instruction Manual.*
- *Prior to proceeding with disassembly operations, comply with the **GENERAL SAFETY RULES** and drain each components of the machine filled with fluids, both in the reservoirs and the relevant systems.*

**WARNING**

Ensure that the attachment is safely resting on to the ground before repairing, adjusting, or servicing machines fitted with hydraulically, mechanically or cable controlled attachments (such as excavators, loaders, dozers, scrapers, etc.). Should it be necessary to partially or fully raise the hydraulically, mechanically, or cable controlled attachment to gain access to certain items, make sure the attachment is adequately retained in the raised position by means other than the hydraulic lift cylinders, cable and/or mechanical devices used for controlling it.

SPECIFICATIONS - WHEEL LOADER LW270

IDENTIFICATION - 2678.260.00.1

MARKING: LW270

ENGINE

Make and model CUMMINS M11C
 Net power at the flywheel 199 kW
 Maximum power speed 2100 rpm
 Maximum torque 128.5 daNm
 Maximum torque speed 1300 rpm
 Diesel type, 4 stroke, direct injection, turbocharged
 Number of cylinders 6
 Bore x stroke 125 x 147 mm
 Total displacement 10800 cm³
 Valve/rocker operation lash:
 - intake 0.35 mm
 - exhaust 0.70 mm
 Firing order 1-5-3-6-2-4
 Minimum starting temperature: - 20°C
 Engine coolant high temperature sender setting
 101 + 2 °C
 Engine oil low pressure switch setting
 0,5 ± 0,1 bar (at idle speed)

ENGINE SPEEDS

Minimum idle speed (no load) 720 rpm
 Maximum idle speed (no load) 2310 rpm
 Converter stall speed 2200 ± 50 rpm
 Steering stall at idle speed > 600 rpm
 Attachment stall 2250 ± 50 rpm
 Full stall 1990 ± 100 rpm

TORQUE CONVERTER

Type: Niigata 13.5" (MS370) single-stage, single-phase
 Main converter pressure bar
 Converter safety valve pressure 7.2 bar

TRANSMISSION

Maximum ground speeds (forward/reverse) in kph (with 26.5 R25 XHA tires):

Forward speed	kph	Reverse speed	kph
First	7.58	First	8.16
Second	13.81	Second	14.85
Third	22.12	Third	23.66
Fourth	37.14	Fourth	38.62

Oil pump flow rate (at 2100 rpm)
 Front 84.2 lt/min.
 Rear 92.7 lt/min.
 Main pressure on the control valve 21 ~ 24 bar
 Transmission disengagement sensor 15 ± 1 bar
 Transmission induction sensors to gear teeth adjust
 Clearance 0.5 ÷ 0.8 mm
 Transmission oil high temperature sensor setting ..
 122 ± 3°C

AXLES

Axles complete with disc brakes in oil bath.
 Self-locking differentials.
 Planetary final drives.
 Stiff front axle, support structure type
 - reduction ratio 1 : 25.381
 Oscillating rear axle, support structure type
 - reduction ratio 1 : 25.381

TIRES

Type 26.5 R25 XHA tubeless
 Inflating pressure
 - Work: front = 4.25 bar
 rear = 2.75 bar
 - Transfer: front = 2.00 bar
 rear = 2.00 bar
 Wheel tightening torque 78.8 daNm

BRAKES

Delivery brakes pump at nominal speed .. 29.7 lt/min.
 Accumulator recharge start pressure 80 ± 5 bar
 Accumulator recharge end pressure 110 ± 5 bar
 Accumulator pre-charge pressure (1.4 lt) 45 bar
 Transmission disengagement pressure switch
 Setting 15 bar
 Brake oil low pressure sensor setting 60 bar
 Brake lights pressure switch setting 1.8 bar
 Parking brake applied pressure switch setting
 ON 10 bar - OFF 15 bar

STEERING SYSTEM

Cylinders 2 double-acting
 - bore x stroke 80 x 542 mm
 Stand-by/main priority valve setting 206 bar

ATTACHMENT HYDRAULIC SYSTEM

- Sealed type with anti-cavitation and safety valves.
- Pump flow rate at rated speed 193 lt/min.
 - 2 or 3 spool control valve
 - Piloted control
 - Hydraulic double-acting cylinders:
 - Boom control 2
 - Bore x stroke 170 x 920 mm

- Bucket control cylinder
- Bore x stroke 210 x 570 mm
- Pressure relief valve setting 206 bar
- Lift safety valve setting 274 bar
- Bucket roll-back safety valve setting (A1) 230 bar
- Bucket roll-out safety valve setting (B1) ... 186 bar

OPTIONS

Electronic anti-pitch LTS (Load Travel Stabilizer) system.

Three-position control switch as follows:

- Position 0:** disengaged
- Position 1:** LTS engaged with speeds exceeding 7 kph
- Position 2:** (to be used only for maintenance or repair) LTS engaged at all times.
- Accumulator safety valve setting 120 bar

ELECTRICAL SYSTEM

- Operating voltage 24 V
- Batteries in series 2 - 160 Ah
- maintenance - free type
- DELCO starter motor
- Rated power 42MT - 24V - 7.8 kW
- DELCO alternator with voltage regulator
- 21SI - 24V - 70A

WEIGHT

Loader weight with 26.5 R25 tires, 4 m³ bucket, fully filled with fluids and operator 22000 kg.

MAIN DIMENSIONS

Dimensions taken with machine with the loader fitted with 26.5 R25 XHA tires and 4 m³ load capacity bucket.

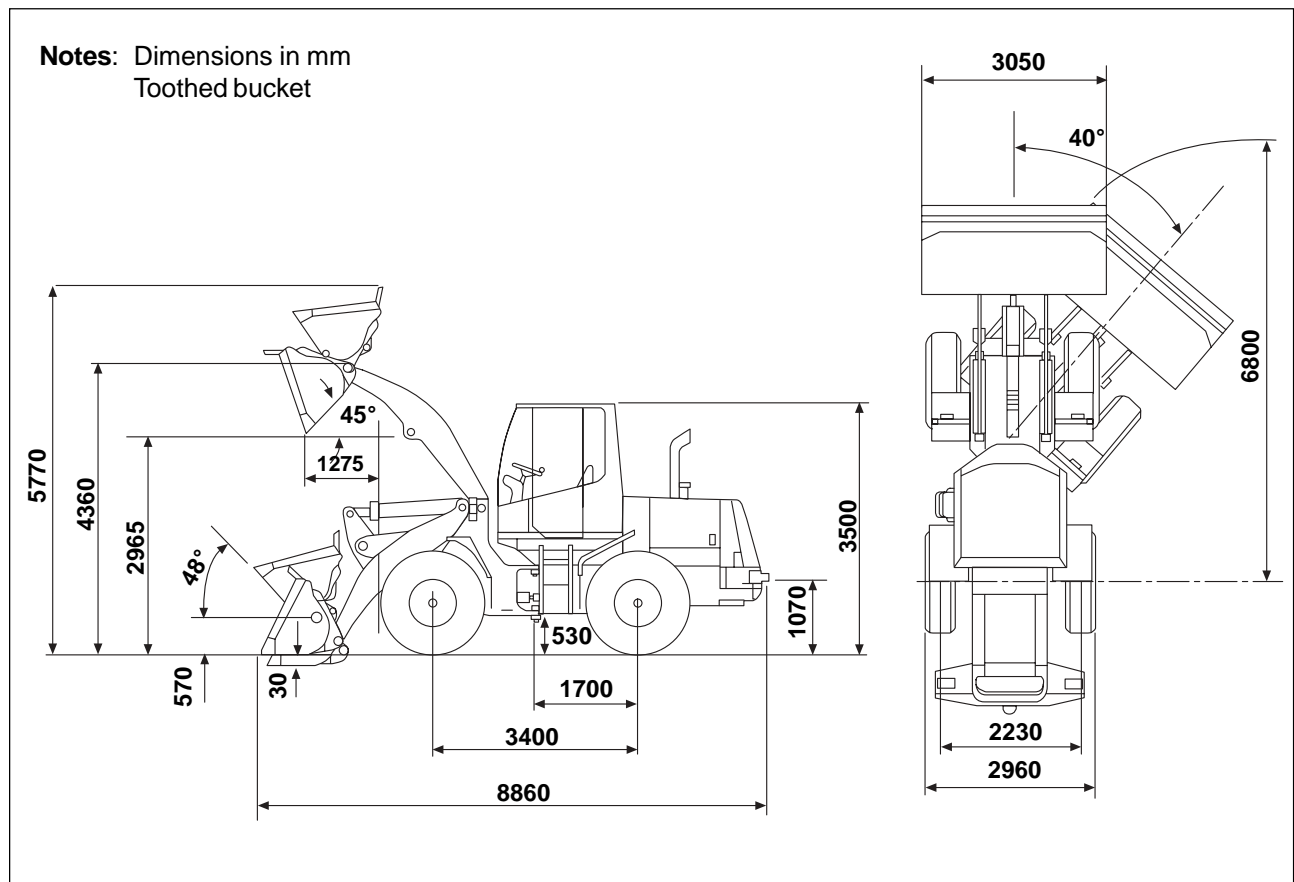

FLUIDS AND CAPACITY TABLE

Component to be filled	Capacity (lts)	Fluids and Lubricants NEW HOLLAND CONSTRUCTION	Technical data and classification	Viscosity (SAE)	Temperature of operation (°C)	
Engine	34	9613292	API CF-4/SG, CCMCD4, MIL-L-2104E, NH 324 G	15W-40 10W-30	-10 +50 -30 +20	
Cooling system	77		NH 900 A	-	-38 +50 (Mixed with water at 50%)	
Transmission	35	9624451	API CF-4/SG, CCMCD4, MIL-L-2104E, NH 324 G	15W-40 10W-30	-10 +50 -20 +50	
Hydraulic and brake system	220	86109085	ISO VG46, DIN 51524 Part 1 e 2, QFH583/HD	-	-20 +50	
Axles	front rear	48 48	961294	API GL5, QFH 586 TR	85W-90	-20 +50
Lubrication of pivot points	-	986180405	QFH 585 GR, NLGI 2	-	-40 +50	
Fuel tank	320	-	-	-	-	

The capacity are intended as "total"

UNITS OF MEASURE

Units of measure used in this manual are those adopted by the International System which replace the units previously used by the M.K.S. system.

Force: decanewton (daN) replaces kilogram (kg)

Pressure: bar, replaces kg/cm²

Torque: decanewton x meter (daNm) replaces kgm

The following tables is to be used to convert units of measure:

	multiply	by	to obtain
Force	kg	0.9807	daN
Pressure	kg/cm ²	0.9807	bar
Torque	kgm	0.9807	daNm

Note - For current service use, the following equivalences can be considered to be valid:
kg = daN; kg/cm² = bar; kgm = daNm.

CLASSIFICATION OF STANDARD COMPONENTS TO DETERMINE THE TIGHTENING TORQUES

Note - In case, in the different sections, the tightening torque is not listed, refer to the table "TIGHTENING TORQUES", only after identifying exactly the component.

The latter is identified by a coded eight digit number, allowing a complete description of the item.

Example:

1 / a b c d e / f g

1 - Standard index digit

It is always represented by the digit 1. This number indicates that the item can be fabricated in a number of versions differing for material and coating.

a - b - c - d - e - Standard base digits

It is a number always composed of five digits identifying dimensional specifications of the item.

f - Material index digit

This digit indicates the material used for a defined item. Its meaning is indicated in the table that follows.

g - Coating index digit

It indicates the coating applied to a defined item.

Material index (f)	Resistance class and material					
	FIAT	UNI	DIN	SAE	BSI	BNA
0	R 40	4D - 4S - 4A		1	A	42
1	R50	5S - 6S		3	P	56
2	R80	8G		5	T	80
3	R100	100	10K	8	V	100
4	Brass	Brass	Messing	Brass	Brass	Laiton
5	Aluminium	Aluminium	Aluminium	Aluminium	Aluminium	Aluminium
6	Copper	Copper	Kupfer	Copper	Copper	Cuivre
7	Blank for other metallic materials					

WARNING

- Lubricate all hardware until 24 dia., with engine oil. Use grease for larger diameters.
- Tolerance on torque: $\pm 5\%$
- Resistance classes R80, R100, R120 must be understood as follows:

10.9 replaces R100		for screws
12.9 " R120		
10 replaces R80		for nuts
12 " R100		

CDT= cadmed; FOSF= phosphated; ZNT= galvanised.

TORQUE TABLES

If correct torque is not specifically indicated in the relevant pages, refer to the following tables.

NUTS (ZNT)					SCREWS (ZNT/DEIDR)		
Strength grade: 10 (R80)					Strength grade: 10.9 (R100)		
Diameter and pitch mm	normal	low type	with polyamide ring		Diameter and pitch mm	normal ZNT daNm	self-locking ZNT daNm
	daNm	daNm	normal daNm	low type daNm			
M6 x 1	1.3	1.2	-	-	M6 x 1	1.3	-
M8 x 1.25	3.2	2.6	3.9	3.2	M8 x 1.25	1.3	3.5
M10 x 1.25	7.2	5.2	8.2	6.2	M10 x 1.25	7.1	7.9
M10 x 1.5	6.5	5	7.7	6	M10 x 1.5	6.5	7
M12 x 1.25	13	8.7	14.5	10.2	M12 x 1.25	12.7	13.9
M12 x 1.75	11	8.1	12.9	9.6	M12 x 1.75	11	12
M14 x 1.5	19.5	13	21.6	15	M14 x 1.5	20	22
M14 x 2	18	12.5	20	14.6	M14 x 2	18	19
M16 x 1.5	30	17	34	20	M16 x 1.5	30	33
M16 x 2	-	-	-	-	M16 x 2	-	-
M18 x 1.5	45	25	50	29	M18 x 1.5	45	48
M18 x 2.5	-	-	-	-	M18 x 2.5	-	-
M20 x 1.5	60	30.5	64.5	35	M20 x 1.5	60	65
M20 x 2.5	-	-	-	-	M20 x 2.5	-	-
M22 x 1.5	80	41	-	-	M22 x 1.5	80	90
M22 x 2.5	-	-	-	-	M22 x 2.5	-	-
M24 x 2	100	47	108	52.5	M24 x 2	100	110
M24 x 3	-	-	-	-	M24 x 3	-	-
M27 x 2	95	40.1	-	-	M27 x 2	100	-
M30 x 2	130	49.4	-	-	M30 x 2	140	-
M33 x 2	170	-	-	-	M33 x 2	190	-
M36 x 3	220	-	-	-	M36 x 3	240	-

PAGE LEFT INTENTIONALLY BLANK

SECTION 1

ENGINE

TABLE OF CONTENTS

PARAGRAPH	SUBJECT	PAGE
1.1	IDENTIFICATION DATA	1
1.2	GENERAL SPECIFICATIONS OF SERIES "M11" ENGINE	2
1.3	ENGINE SUPPORTS	5
1.4	DIAGRAMS OF SERIES "M11" ENGINES	6

PAGE LEFT INTENTIONALLY BLANK

1.1 IDENTIFICATION DATA

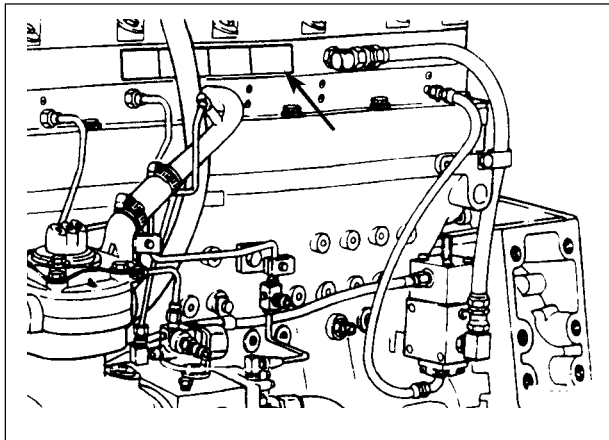

Fig. 1-1

Data plates of series M11 engine

The engine identification plate provides specific information for your engine.

Note: the Engine Data plate must not be replaced without approval by Cummins Engine Company Inc.

The identification plate is located on the injection pump side of the engine, on the rocker arm cover side.

1. Engine serial number (ESN)
2. Model
3. Engine power and speed

Engine No.	Advert. Power HP/KW	at	RPM	Idle Speed	FOR CONSTANT SPEED USE ONLY	IMPORTANT ENGINE INFORMATION: This engine conforms to U.S. EPA and California regulations for heavy duty nonroad compression ignition diesel cycle engines as applicable. 19 THIS ENGINE IS CERTIFIED TO OPERATE ON DIESEL FUEL
Family				CID/L		
S.O. No.	Fuel rate at Advert. Power	at	mm ³ stroke	Inj. Timing		
Date of	Jnj. Set	IN/mm		CPL		
Model	Valve Lash Cold	IN/mm	Int.			
Ref. No.	Manufactured by Cummins Engine Co. Inc. Made in U.S.A.			3074269	Warranty St. Date	

Fig. 1-2

Data plate of fuel injection pump

The data plate for fuel injection pump is located on the upper side of the pump itself.

It provides information relative to the calibration of the pump.

This as a preview PDF file from best-manuals.com



Download full PDF manual at best-manuals.com