

544J Loader Repair

(Serial No. 611800-)

TECHNICAL MANUAL 544J Loader Repair (S.N. 611800—)

TM10244 16JAN08 (ENGLISH)

For complete service information also see:

544J Loader Operation and Test (S.N. 611800—)	TM10229
544J Loader Operator's Manual (S.N. 611800—)	OMT229869
Alternators and Starting Motors.....	CTM77
POWERTECH™ 4.5 L and 6.8 L Diesel Engines—Base Engine	CTM104
TeamMate™ IV 1200 and 1400 Series Inboard Planetary Axles	CTM442
POWERTECH E™ 4.5 & 6.8L Diesel Engines—Level 16 Electronic Fuel System with Denso HPCR	CTM502
Super Caddy Oil Cleanup Procedure.....	CTM310
120 Series Hydraulic Cylinders	TM-H120A
125 Series Hydraulic Cylinders	TM-H125A

**Worldwide Construction
And Forestry Division**

LITHO in U.S.A.

Introduction

Foreword

This manual is written for an experienced technician. Essential tools required in performing certain service work are identified in this manual and are recommended for use.

Live with safety: Read the safety messages in the introduction of this manual and the cautions presented throughout the text of the manual.



This is the safety-alert symbol. When you see this symbol on the machine or in this manual, be alert to the potential for personal injury.

Technical manuals are divided in two parts: repair and operation and tests. Repair sections tell how to repair the components. Operation and tests sections help you identify the majority of routine failures quickly.

Information is organized in groups for the various components requiring service instruction. At the beginning of each group are summary listings of all applicable essential tools, service equipment and tools, other materials needed to do the job, service parts kits, specifications, wear tolerances, and torque values.

Technical Manuals are concise guides for specific machines. They are on-the-job guides containing only the vital information needed for diagnosis, analysis, testing, and repair.

Fundamental service information is available from other sources covering basic theory of operation, fundamentals of troubleshooting, general maintenance, and basic type of failures and their causes.

DX, TMIFC -19-29SEP98-1/1

Technical Information Feedback Form

We need your help to continually improve our technical publications. Please copy this page and FAX or mail your comments, ideas and improvements.

SEND TO: John Deere Dubuque Works
P.O. Box 538
Attn: Publications Supervisor, Dept. 303
Dubuque, IA 52004-0538

FAX NUMBER: 563-589-5800

Ideas, Comments (Please State Page Number): _____

OVERALL, how would you rate the quality of this publication? (Check one)

1 Poor 2 3 Fair 4 5 Good 6 7 Very Good 8 9 Excellent 10

Company Name: _____

Technician Name: _____

Address: _____

Phone: _____

Fax No.: _____

Dealer Acct. No.: _____

THANK YOU!

Introduction

Contents

SECTION 00—General Information

Group 0001—Safety Information

SECTION 01—Wheels

Group 0110—Powered Wheels and Fasteners

SECTION 02—Axles and Suspension Systems

Group 0200—Removal and Installation

Group 0225—Axle Shafts and U-Joints

Group 0250—Axle Shaft, Bearings, Reduction Gears

Group 0260—Hydraulic System

SECTION 03—Transmission

Group 0300—Removal and Installation

Group 0350—Gears, Shafts, Bearings and Power Shift Clutch

Group 0360—Hydraulic System

SECTION 04—Engine

Group 0400—Removal and Installation

SECTION 05—Engine Auxiliary Systems

Group 0505—Cold Weather Starting Aids

Group 0510—Cooling System

Group 0520—Intake System

Group 0530—External Exhaust System

Group 0560—External Fuel Supply Systems

SECTION 07—Dampener Drive

Group 0752—Elements

SECTION 09—Steering System

Group 0960—Hydraulic System

SECTION 10—Service Brakes

Group 1011—Active Elements

Group 1060—Hydraulic System

SECTION 11—Park Brake

Group 1111—Active Elements

Group 1160—Hydraulic System

SECTION 17—Frame or Supporting Structure

Group 1740—Frame Installation

Group 1746—Frame Bottom Guards

Group 1749—Chassis Weights

SECTION 18—Operator's Station

Group 1800—Removal and Installation

Group 1810—Operator Enclosure

Group 1830—Heating and Air Conditioning

SECTION 19—Sheet Metal and Styling

Group 1910—Hood or Engine Enclosure

SECTION 31—Loader

Group 3102—Bucket

Group 3140—Frames

Group 3160—Hydraulic System

SECTION 9900—Dealer Fabricated Tools

Group 0099—Dealer Fabricated Tools

All information, illustrations and specifications in this manual are based on the latest information available at the time of publication. The right is reserved to make changes at any time without notice.

COPYRIGHT © 2008
DEERE & COMPANY
Moline, Illinois
All rights reserved
A John Deere ILLUSTRATION® Manual
Previous Editions
Copyright © 2007

00

01

02

03

04

05

07

09

10

11

Contents

00

01

02

03

04

05

07

09

10

11

Contents

17

18

19

31

9900

INDX

Contents

17

18

19

31

9900

INDX

Section 00 General Information

Contents

Page

Group 0001—Safety Information

- Recognize Safety Information00-0001-1
- Follow Safety Instructions00-0001-1
- Operate Only If Qualified.00-0001-2
- Wear Protective Equipment.00-0001-2
- Avoid Unauthorized Machine
 - Modifications00-0001-2
- Add Cab Guarding For Special Uses00-0001-3
- Inspect Machine00-0001-3
- Stay Clear of Moving Parts00-0001-3
- Avoid High-Pressure Fluids.00-0001-4
- Avoid High-Pressure Oils00-0001-4
- Beware of Exhaust Fumes00-0001-5
- Prevent Fires.00-0001-5
- Prevent Battery Explosions00-0001-5
- Handle Chemical Products Safely00-0001-6
- Dispose of Waste Properly00-0001-6
- Prepare for Emergencies.00-0001-6
- Use Steps and Handholds Correctly00-0001-7
- Start Only From Operator’s Seat.00-0001-7
- Use and Maintain Seat Belt.00-0001-7
- Prevent Unintended Machine Movement.00-0001-8
- Avoid Work Site Hazards00-0001-9
- Use Special Care When Operating
 - Loader.00-0001-10
- Keep Riders Off Machine00-0001-10
- Avoid Backover Accidents.00-0001-11
- Avoid Machine Tip Over00-0001-11
- Operating on Slopes00-0001-12
- Operating or Traveling On Public Roads.00-0001-12
- Inspect and Maintain ROPS00-0001-13
- Add and Operate Attachments Safely00-0001-13
- Park And Prepare For Service Safely00-0001-14
- Service Cooling System Safely00-0001-14
- Remove Paint Before Welding or
 - Heating00-0001-15
- Make Welding Repairs Safely00-0001-16
- Drive Metal Pins Safely.00-0001-16

Contents

00

Recognize Safety Information

This is the safety alert symbol. When you see this symbol on your machine or in this manual, be alert for the potential of personal injury.

Follow the precautions and safe operating practices highlighted by this symbol.

A signal word — DANGER, WARNING, or CAUTION — is used with the safety alert symbol. DANGER identifies the most serious hazards.

On your machine, DANGER signs are red in color, WARNING signs are orange, and CAUTION signs are yellow. DANGER and WARNING signs are located near specific hazards. General precautions are on CAUTION labels.



T1133555 -UN-28AUG00

T1133588 -19-28AUG00

TX03679,00016CC -19-01OCT07-1/1

Follow Safety Instructions

Read the safety messages in this manual and on the machine. Follow these warnings and instructions carefully. Review them frequently. Keep safety signs in good condition. Replace missing or damaged safety signs. Replacement safety signs are available from your authorized John Deere dealer.

Be sure all operators of this machine understand every safety message. Replace operator's manual and safety labels immediately if missing or damaged.



T1133556 -UN-24AUG00

TX03679,00016F9 -19-18OCT07-1/1

Safety Information

00
0001
2

Operate Only If Qualified

Do not operate this machine unless you have read the operator's manual carefully and you have been qualified by supervised training and instruction.

Familiarize yourself with the job site and your surroundings before operating. Try all controls and

machine functions with the machine in an open area before starting to work.

Know and observe all safety rules that may apply to your work situation and your work site.

TX03679,00016FA -19-01OCT07-1/1

Wear Protective Equipment

Guard against injury from flying pieces of metal or debris; wear goggles or safety glasses.

Wear close fitting clothing and safety equipment appropriate to the job.

Prolonged exposure to loud noise can cause impairment or loss of hearing. Wear suitable hearing protection such as earmuffs or earplugs to protect against objectionable or uncomfortable loud noises.

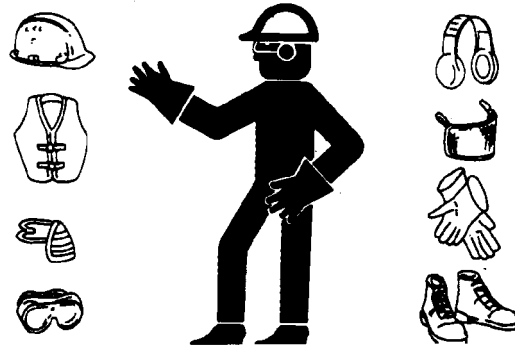

TS206 -UN-23AUG88

TX03679,00016D0 -19-01OCT07-1/1

Avoid Unauthorized Machine Modifications

John Deere recommends using only genuine John Deere replacement parts to ensure machine performance. Never substitute genuine John Deere parts with alternate parts not intended for the application as these can create hazardous situations or hazardous performance. Non-John Deere Parts, or any damage or failures resulting from their use are not covered by any John Deere warranty.

Modifications of this machine, or addition of unapproved products or attachments, may affect

machine stability or reliability, and may create a hazard for the operator or others near the machine. The installer of any modification which may affect the electronic controls of this machine is responsible for establishing that the modification does not adversely affect the machine or its performance.

Always contact an authorized John Deere dealer before making machine modifications that change the intended use, weight or balance of the machine, or that alter machine controls, performance or reliability.

AM40430,00000A9 -19-14JAN08-1/1

Add Cab Guarding For Special Uses

Special work situations or machine attachments may create an environment with falling or flying objects. Loading logs, using fork attachments, or operating in waste management applications requires special work tools. Added cab guarding to protect the operator may also be required.

Use load-clamping grapples to keep bulky loads from falling and add special screens or guarding when objects may be directed toward the cab. Contact your authorized John Deere dealer for information on devices intended to protect the operator from falling or flying objects in special work situations.

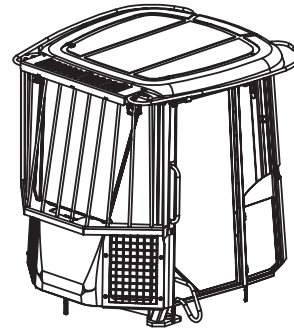

T141883 -JUN-04MAY01

TX03679,00017C6 -19-18OCT07-1/1

Inspect Machine

Inspect machine carefully each day by walking around it before starting.

Keep all guards and shields in good condition and properly installed. Fix damage and replace worn or broken parts immediately. Pay special attention to hydraulic hoses and electrical wiring.



T6607AQ -JUN-18OCT88

TX03679,0001734 -19-01OCT07-1/1

Stay Clear of Moving Parts

Entanglements in moving parts can cause serious injury.

Stop engine before examining, adjusting or maintaining any part of machine with moving parts.

Keep guards and shields in place. Replace any guard or shield that has been removed for access as soon as service or repair is complete.

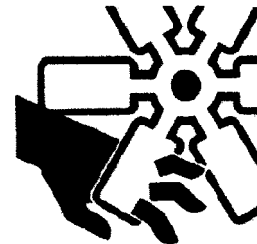

T133592 -JUN-12SEP01

TX03679,00016D2 -19-01OCT07-1/1

00
0001
4

Avoid High-Pressure Fluids

Escaping fluid under pressure can penetrate the skin causing serious injury.

Avoid the hazard by relieving pressure before disconnecting hydraulic or other lines. Tighten all connections before applying pressure.

Search for leaks with a piece of cardboard. Protect hands and body from high pressure fluids.

If an accident occurs, see a doctor immediately. Any fluid injected into the skin must be surgically removed within a few hours or gangrene may result. Doctors unfamiliar with this type of injury should reference a knowledgeable medical source. Such information is available from Deere & Company Medical Department in Moline, Illinois, U.S.A.

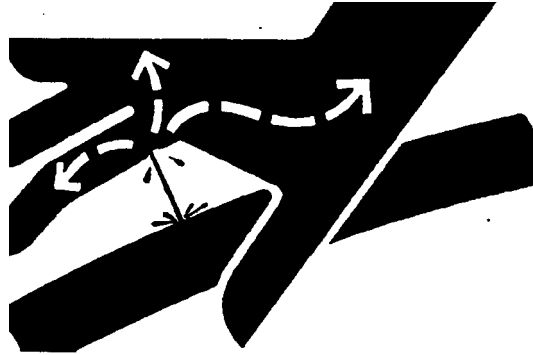

X9811 -UN-23AUG88

DX,FLUID -19-03MAR93-1/1

Avoid High-Pressure Oils

This machine uses a high-pressure hydraulic system. Escaping oil under pressure can penetrate the skin causing serious injury.

Never search for leaks with your hands. Protect hands. Use a piece of cardboard to find location of escaping oil. Stop engine and relieve pressure before disconnecting lines or working on hydraulic system.

If hydraulic oil penetrates your skin, see a doctor immediately. Injected oil must be removed surgically within hours or gangrene may result. Contact a knowledgeable medical source or the Deere & Company Medical Department in Moline, Illinois, U.S.A.

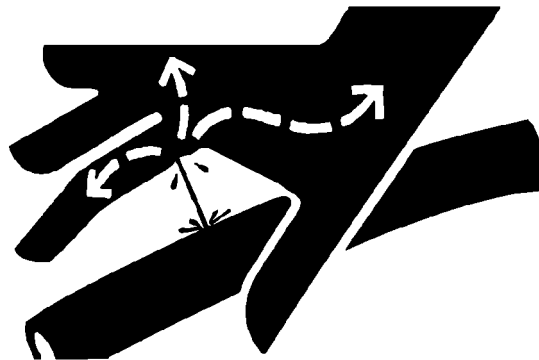

T133509 -UN-17MAR06

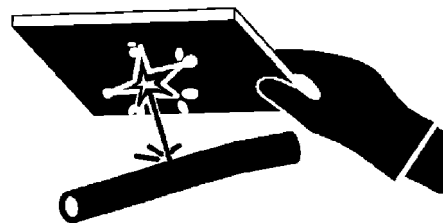

T133840 -UN-20SEP00

TX03679,00016D3 -19-01OCT07-1/1

Beware of Exhaust Fumes

Prevent asphyxiation. Engine exhaust fumes can cause sickness or death.

If you must operate in a building, provide adequate ventilation. Use an exhaust pipe extension to remove the exhaust fumes or open doors and windows to bring outside air into the area.

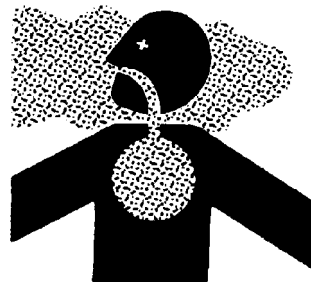

T133546 -UN-24AUG00

TX03679.00016D4 -19-03JAN07-1/1

Prevent Fires

Handle Fuel Safely: Store flammable fluids away from fire hazards. Never refuel machine while smoking or when near sparks or flame.

Clean Machine Regularly: Keep trash, debris, grease and oil from accumulating in engine compartment, around fuel lines, hydraulic lines and electrical wiring. Never store oily rags or flammable materials inside a machine compartment.

Maintain Hoses and Wiring: Replace hydraulic hoses immediately if they begin to leak, and clean up any oil spills. Examine electrical wiring and connectors frequently for damage.

Keep A Fire Extinguisher Available: Always keep a multipurpose fire extinguisher on or near the machine. Know how to use extinguisher properly.

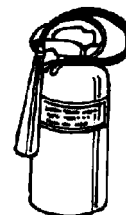

T133552 -UN-14SEP00

T133553 -UN-07SEP00

T133554 -UN-07SEP00

TX03679.00016F5 -19-08MAR07-1/1

Prevent Battery Explosions

Battery gas can explode. Keep sparks, lighted matches, and open flame away from the top of battery.

Never check battery charge by placing a metal object across the posts. Use a voltmeter or hydrometer.

Do not charge a frozen battery; it may explode. Warm battery to 16°C (60°F).



TS204 -UN-23AUG88

TX03679.000174A -19-03JAN07-1/1

00
0001
6

Handle Chemical Products Safely

Exposure to hazardous chemicals can cause serious injury. Under certain conditions, lubricants, coolants, paints and adhesives used with this machine may be hazardous.

If uncertain about safe handling or use of these chemical products, contact your authorized John Deere dealer for a Material Safety Data Sheet (MSDS) or go to internet website <http://www.jdmsds.com>. The MSDS describes physical and health hazards, safe use procedures, and emergency response techniques for chemical substances. Follow MSDS recommendations to handle chemical products safely.

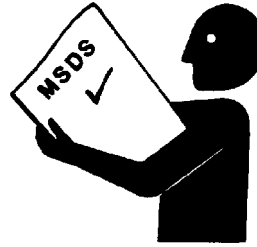

T133580 -UN-25AUG00

TX03679,00016D7 -19-14JAN08-1/1

Dispose of Waste Properly

Improper disposal of waste can threaten the environment. Fuel, oils, coolants, filters and batteries used with this machine may be harmful if not disposed of properly.

Never pour waste onto the ground, down a drain, or into any water source.

Air conditioning refrigerants can damage the atmosphere. Government regulations may require using a certified service center to recover and recycle used refrigerants.

If uncertain about the safe disposal of waste, contact your local environmental or recycling center or your dealer for more information.

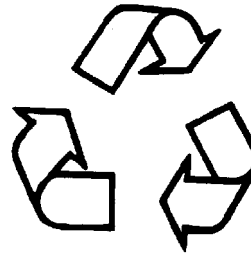

T133567 -UN-25AUG00

TX03679,0001733 -19-28NOV06-1/1

Prepare for Emergencies

Be prepared if an emergency occurs or a fire starts.

Keep a first aid kit and fire extinguisher handy.

Keep emergency numbers for doctors, ambulance service, hospital, and fire department near your telephone.

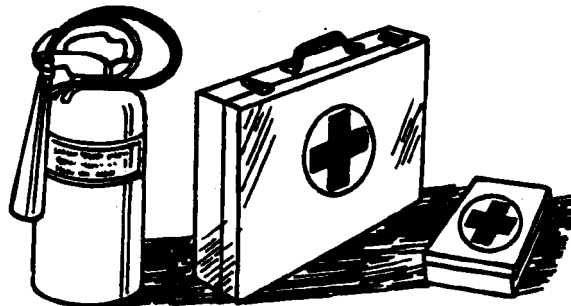

TS291 -UN-23AUG88

TX03679,000174B -19-31JAN07-1/1

Use Steps and Handholds Correctly

Prevent falls by facing the machine when you get on and off. Maintain 3-point contact with steps and handrails. Never use machine controls as handholds.

Use extra care when mud, snow, or moisture present slippery conditions. Keep steps clean and free of grease or oil. Never jump when exiting machine. Never mount or dismount a moving machine.

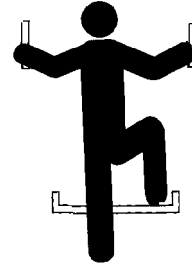

T1133468 -UN-30AUG00

TX03679.00016F2 -19-25JAN07-1/1

Start Only From Operator's Seat

Avoid unexpected machine movement. Start engine only while sitting in operator's seat. Ensure all controls and working tools are in proper position for a parked machine.

Never attempt to start engine from the ground. Do not attempt to start engine by shorting across the starter solenoid terminals.



T1133715 -UN-07SEP00

TX03679.0001799 -19-03JAN07-1/1

Use and Maintain Seat Belt

Use seat belt when operating machine. Remember to fasten seat belt when loading and unloading from trucks and during other uses.

Examine seat belt frequently. Be sure webbing is not cut or torn. Replace seat belt immediately if any part is damaged or does not function properly.

The complete seat belt assembly should be replaced every 3 years, regardless of appearance.



**USE
SEAT
BELT**

T1133716 -19-14SEP00

TX03679.00016DD -19-20MAR07-1/1

00
0001
8

Prevent Unintended Machine Movement

When coworkers are present, disable hydraulics.

Lower all equipment to the ground during work interruptions. Lock transmission control in neutral, engage park brake and stop engine before allowing anyone to approach the machine.

Follow these same precautions before standing up, leaving the operator's seat, or exiting the machine.

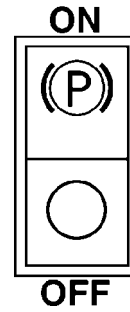

T142001 -UN-15MAY01

TX03679,00017C7 -19-08MAR07-1/1

Avoid Work Site Hazards

Avoid contact with gas lines, buried cables and water lines. Call utility line location services to identify all underground utilities before starting work.

Prepare work site properly. Avoid operating near structures or objects that could fall onto the machine. Clear away debris that could move unexpectedly if run over.

Avoid boom or attachment contact with overhead obstacles or overhead electrical lines. Never move machine closer than 3 m (10 ft) plus twice the line insulator length to overhead wires.

Keep bystanders clear at all times. Use barricades or a signal person to keep vehicles and pedestrians away. Use a signal person if moving machine in congested areas or where visibility is restricted. Always keep signal person in view. Coordinate hand signals before starting machine.

Operate only on solid footing with strength sufficient to support machine. Be especially alert working near embankments or excavations.

Avoid working under over-hanging embankments or stockpiles that could collapse under or on machine.

Reduce machine speed when operating with tool on or near ground when obstacles may be hidden (e.g., during snow removal or clearing mud, dirt, etc.). At high speeds hitting obstacles (rocks, uneven concrete or manholes) can cause a sudden stop. Always wear your seatbelt.

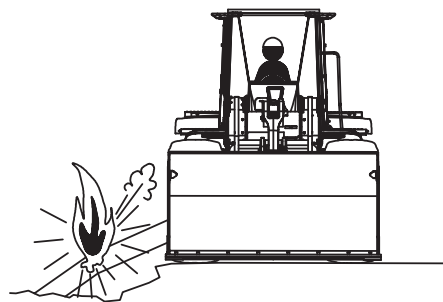

T141894 -UN-15JUN01

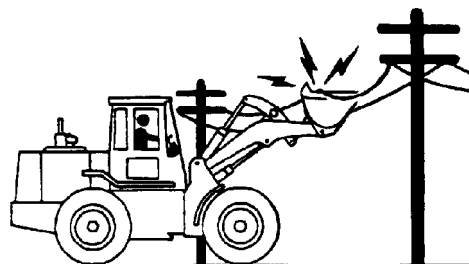

T141670 -UN-24APR01

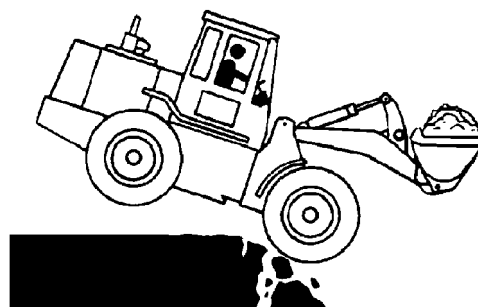

T141672 -UN-04MAY01

00
0001
10

Use Special Care When Operating Loader

Never use the loader to lift people. Do not allow anyone to ride in the bucket or use the bucket as a work platform.

Operate carefully with raised loads. Raising the load reduces machine stability, especially on side slopes or an unstable surface. Drive and turn slowly with a raised load.

Ensure that objects in the bucket are secure. Do not attempt to lift or carry objects that are too big or too long to fit inside the bucket unless secured with an adequate chain or other device. Keep bystanders away from raised loads.

Be careful when lifting objects. Never attempt to lift objects too heavy for your machine. Assure machine stability and hydraulic capability with a test lift before attempting other maneuvers. Use an adequate chain or sling and proper rigging techniques to attach and stabilize loads. Never lift an object above or near another person.

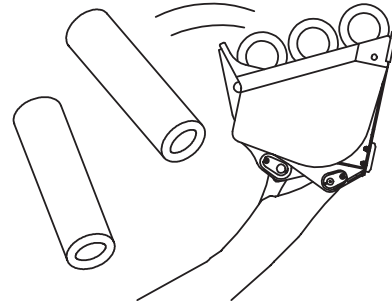
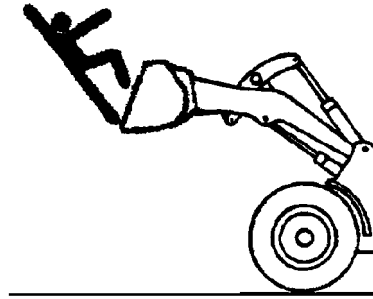

T141957 -UN-15MAY01

T141902 -UN-07MAY01

TX03768,0000B70 -19-14MAY01-1/1

Keep Riders Off Machine

Only allow operator on machine.

Riders are subject to injury. They may fall from machine, be caught between machine parts, or be struck by foreign objects.

Riders may obstruct operator's view or impair his ability to operate machine safely.

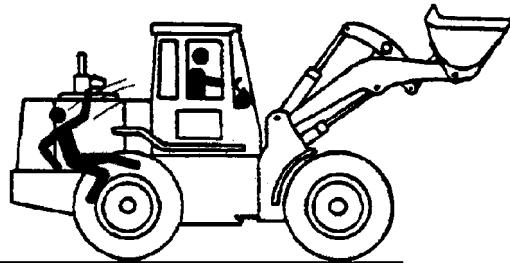

T141671 -UN-04MAY01

TX03679,000179B -19-20APR01-1/1

Avoid Backover Accidents

Before moving machine, be sure all persons are clear of machine path. Turn around and look directly for best visibility. Use mirrors to assist in checking all around machine. Keep windows and mirrors clean, adjusted, and in good repair.

Be certain reverse warning alarm is working properly.

Use a signal person when backing if view is obstructed or when in close quarters. Keep signal person in view at all times. Use prearranged hand signals to communicate.

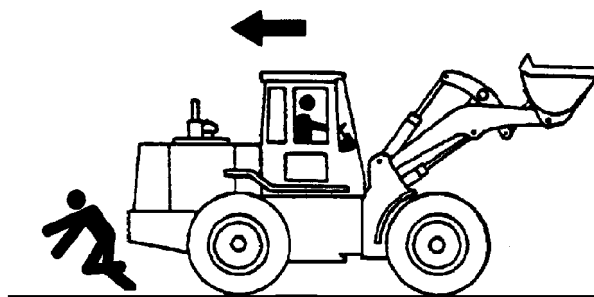

T-141673 -UN-04MAY01

TX03679,000179C -19-20APR01-1/1

Avoid Machine Tip Over

Use seat belt at all times.

Do not jump if the machine tips. You will be unlikely to jump clear and the machine may crush you.

Load and unload from trucks or trailers carefully. Be sure truck is wide enough and on a firm level surface. Use loading ramps and attach them properly to truck bed.

Be careful on slopes. Avoid sharp turns. Balance loads so weight is evenly distributed and load is stable. Carry tools and loads close to the ground to aid visibility and lower center of gravity. Use extra care on soft, rocky or frozen ground.

Know the capacity of the machine. Do not overload. Be careful with heavy loads. Using oversize buckets or lifting heavy objects reduces machine stability.

Ensure solid footing. Use extra care in soft ground conditions that may not uniformly support the wheels, especially when raising the boom. Do not operate close to banks or open excavations that may cave in and cause machine to tip or fall.



**USE
SEAT
BELT**

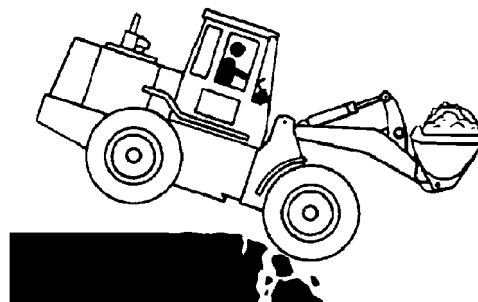
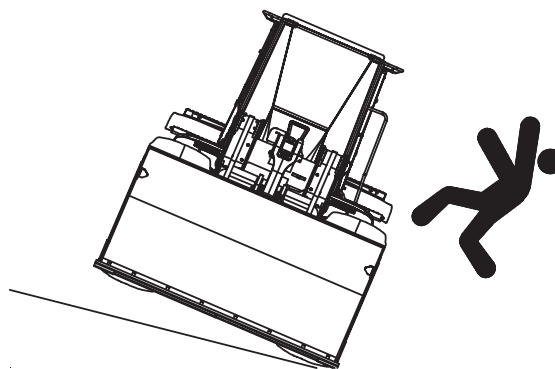

T-133716 -19-14SEP00

T-141676 -UN-04MAY01

T-141672 -UN-04MAY01

TX03679,000179D -19-02MAY01-1/1

00
0001
12

Operating on Slopes

Avoid side slope travel whenever possible. Drive up steep slope in forward and down in reverse.

Select low gear speed before starting down slope. The grade of the slope will be limited by ground condition and load being handled.

Use service brakes to control speed. Sudden brake application with a loaded bucket on downhill side could cause machine to tip forward.

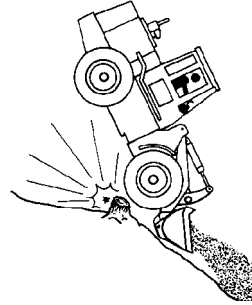

T141881 -UN-30APR01

TX03679,000179E -19-14MAY01-1/1

Operating or Traveling On Public Roads

Machines that work near vehicle traffic or travel slower than normal highway speeds must have proper lighting and markings to assure they are visible to other drivers.

Install additional lights, beacons, slow moving vehicle (SMV) emblems, or other devices and use as required to make the machine visible and identify it as a work machine. Check state and local regulations to assure compliance. Keep these devices clean and in working condition.

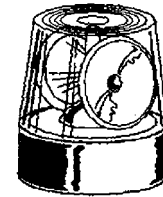
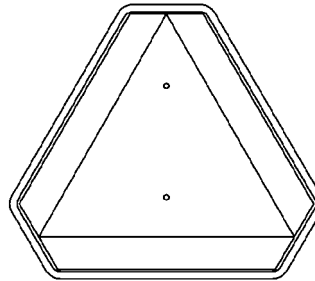

T141891 -UN-22MAY01

TX03679,00017C8 -19-02MAR07-1/1

Inspect and Maintain ROPS

A damaged roll-over protective structure (ROPS) should be replaced, not reused.

The protection offered by ROPS will be impaired if ROPS is subjected to structural damage, is involved in an overturn incident, or is in any way altered by welding, bending, drilling, or cutting.

If ROPS was loosened or removed for any reason, inspect it carefully before operating the machine again.

To maintain the ROPS:

- Replace missing hardware using correct grade hardware.
- Check hardware torque.
- Check isolation mounts for damage, looseness or wear; replace them if necessary.
- Check ROPS for cracks or physical damage.

TX03679.000179F -19-07SEP06-1/1

Add and Operate Attachments Safely

Always verify compatibility of attachments by contacting your authorized dealer. Adding unapproved attachments may affect machine stability or reliability, and may create a hazard for others near the machine.

Ensure that a qualified person is involved in attachment installation. Add guards to machine if operator protection is required or recommended. Verify

that all connections are secure and attachment responds properly to controls.

Carefully read attachment manual and follow all instructions and warnings. In an area free of bystanders and obstructions, carefully operate attachment to learn its characteristics and range of motion.

TX03679.00016F0 -19-24JAN07-1/1

00
0001
14

Park And Prepare For Service Safely

Warn others of service work. Always park and prepare your machine for service or repair properly.

- Park machine on a level surface and lower equipment to the ground.
- Engage park brake.
- Stop engine and remove key.
- Install articulation locking bar.
- Attach a “Do Not Operate” tag in an obvious place in the operator’s station.

Securely support machine or attachment before working under it.

- Do not support machine with boom, bucket, or other hydraulically actuated equipment.
- Do not support machine with cinder blocks or wooden pieces that may crumble or crush.
- Do not support machine with a single jack or other devices that may slip out of place.

Understand service procedures before beginning repairs. Keep service area clean and dry. Use two people whenever the engine must be running for service work.

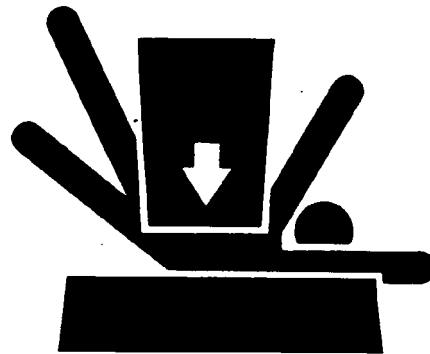

T133332 -19-14DEC01

TS229 -UN-23AUG88

TX03679,00017A0 -19-18SEP01-1/1

Service Cooling System Safely

Explosive release of fluids from pressurized cooling system can cause serious burns.

Do not service radiator through the radiator cap. Only fill through the surge tank filler cap.

Shut off engine. Only remove surge tank filler cap when cool enough to touch with bare hands. Slowly loosen cap to relieve pressure before removing completely.



TS281 -UN-23AUG88

O006043,0001B38 -19-14NOV06-1/1

Remove Paint Before Welding or Heating

Avoid potentially toxic fumes and dust.

Hazardous fumes can be generated when paint is heated by welding, soldering, or using a torch.

Remove paint before heating:

- Remove paint a minimum of 100 mm (4 in.) from area to be affected by heating. If paint cannot be removed, wear an approved respirator before heating or welding.
- If you sand or grind paint, avoid breathing the dust. Wear an approved respirator.
- If you use solvent or paint stripper, remove stripper with soap and water before welding. Remove solvent or paint stripper containers and other flammable material from area. Allow fumes to disperse at least 15 minutes before welding or heating.

Do not use a chlorinated solvent in areas where welding will take place.

Do all work in an area that is well ventilated to carry toxic fumes and dust away.

Dispose of paint and solvent properly.

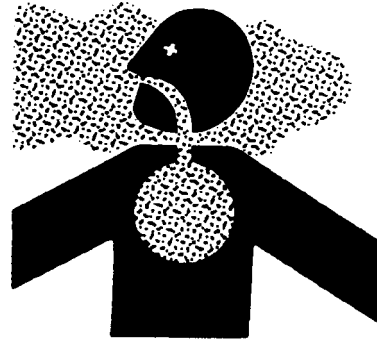

TS220 -UN-23AUG88

DX,PAINT -19-24JUL02-1/1

00
0001
16

Make Welding Repairs Safely

IMPORTANT: Disable electrical power before welding.
Turn off main battery switch or disconnect positive battery cable.
Separate harness connectors to engine and vehicle microprocessors.



Avoid welding or heating near pressurized fluid lines. Flammable spray may result and cause severe burns if pressurized lines fail as a result of heating. Do not let heat go beyond work area to nearby pressurized lines.

Remove paint properly. Do not inhale paint dust or fumes. Use a qualified welding technician for structural repairs. Make sure there is good ventilation. Wear eye protection and protective equipment when welding.

T133547 -UN-31AUG00

TX03679,00016D5 -19-12SEP07-1/1

Drive Metal Pins Safely

Always wear protective goggles or safety glasses and other protective equipment before striking hardened parts. Hammering hardened metal parts such as pins and bucket teeth may dislodge chips at high velocity.

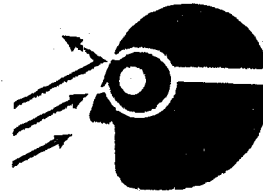

Use a soft hammer or a brass bar between hammer and object to prevent chipping.

T133738 -UN-14SEP00

TX03679,0001745 -19-17JUL07-1/1

Section 01 Wheels

Contents

Page

Group 0110—Powered Wheels and Fasteners

Wheel Remove and Install	01-0110-1
Tire Remove	01-0110-2
Tire Install	01-0110-4

01

Contents

01

Wheel Remove and Install

⚠ CAUTION: Prevent crushing injury from heavy component. Use appropriate lifting device.

1. Raise machine and place 10-ton shop stands under axle.

⚠ CAUTION: Prevent crushing injury from heavy component. Use appropriate lifting device.

2. Place wheel lift under wheel. Fasten safety chain around upper part of tire.
3. Remove wheel cap screws (1). Remove wheel.
4. Clean mounting surface on wheel and axle flange.
5. Install wheel. Tighten wheel cap screws to specification.

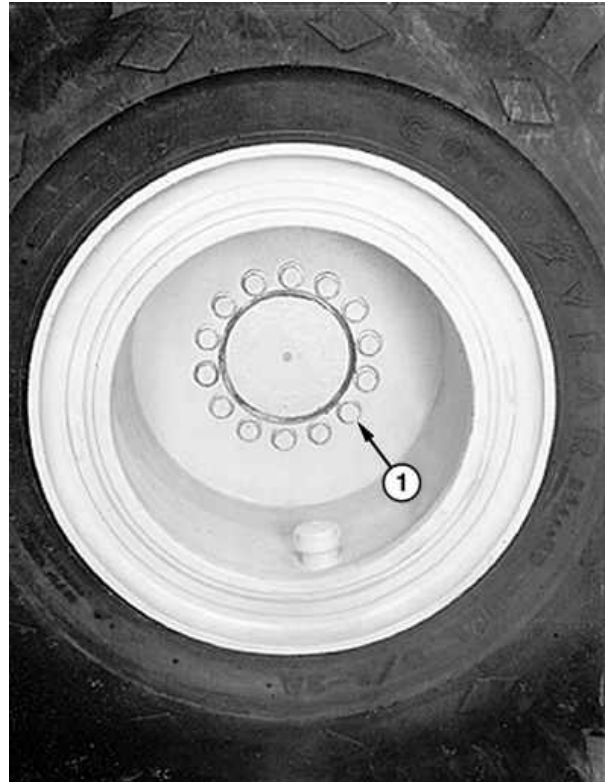

Wheel Cap Screw

Specification

Wheel Cap Screw—Torque..... 678 N•m
500 lb-ft

1—Wheel Cap Screw (14 used)

01
0110
1

TX1021910A -UN-12APR07

MH66O88,00005B3 -19-14MAY07-1/1

Tire Remove

! **CAUTION:** Explosive separation of a tire and rim parts can cause serious injury or death.

Only attempt to mount a tire if you have the proper equipment and experience to perform the job. Have it done by your John Deere dealer or a qualified repair service.

Always maintain the correct tire pressure. Do not inflate the tires above the recommended pressure.

When inflating tires, use a clip-on chuck and extension hose long enough to allow you to stand to one side and NOT in front of or over the tire assembly. Use a safety cage if available.

Inspect tires and wheels daily. Do not operate with low pressure, cuts, bubbles, damaged rims or missing lug bolts and nuts.

Failure to follow proper procedures when demounting a tire from a wheel or rim can produce an explosion which may result in serious bodily injury. Do not attempt to demount a tire unless you have proper equipment and experience to perform the job safely. Have it done by a qualified tire repair service.

Tire can be removed without removing wheel.

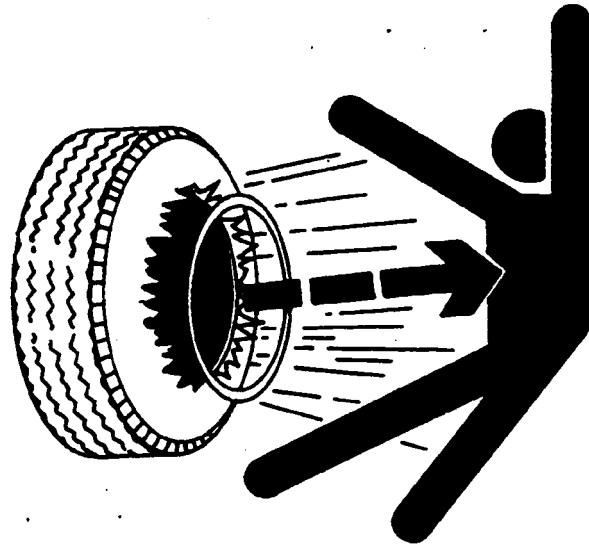

Exploding Tire

TS211 -UN-23AUG88

Continued on next page

SJ25320,000047C -19-07AUG07-1/2

This as a preview PDF file from best-manuals.com



Download full PDF manual at best-manuals.com