

318D, 319D, 320D and 323D Skid Steer Loader Repair (EH Controls)

TECHNICAL MANUAL 318D, 319D, 320D and 323D Skid Steer Loader Repair (EH Controls)

TM11407 25APR12 (ENGLISH)

For complete service information also see:

318D and 320D Skid Steer Loader Operation and Test (EH Controls).....	TM11406
319D and 323D Skid Steer Loader Operation and Test (EH Controls).....	TM11422
318D and 320D Skid Steer Loader Operation and Test (Manual Controls)	TM11398
319D and 323D Skid Steer Loader Operation and Test (Manual Controls)	TM11414
318D, 319D, 320D and 323D Skid Steer Loader Repair (Manual Controls).....	TM11399
318D and 320D Skid Steer Loader Operator's Manual	OMT253020
319D and 323D Skid Steer Loader Operator's Manual	OMT253019
PowerTech E™ 2.4L and 3.0L Diesel Engines Component Technical Manual.....	CTM101019
120 Series Hydraulic Cylinders	CTM114319
Specifications Manual.....	SP458

**Worldwide Construction
And Forestry Division**
LITHO IN U.S.A.

Introduction

Foreword

This manual is written for an experienced technician. Essential tools required in performing certain service work are identified in this manual and are recommended for use.

Live with safety: Read the safety messages in the introduction of this manual and the cautions presented throughout the text of the manual.



This is the safety-alert symbol. When you see this symbol on the machine or in this manual, be alert to the potential for personal injury.

Technical manuals are divided in two parts: repair and operation and tests. Repair sections tell how to repair the components. Operation and tests sections help you identify the majority of routine failures quickly.

Information is organized in groups for the various components requiring service instruction. At the beginning of each group are summary listings of all applicable essential tools, service equipment and tools, other materials needed to do the job, service parts kits, specifications, wear tolerances, and torque values.

Technical Manuals are concise guides for specific machines. They are on-the-job guides containing only the vital information needed for diagnosis, analysis, testing, and repair.

Fundamental service information is available from other sources covering basic theory of operation, fundamentals of troubleshooting, general maintenance, and basic type of failures and their causes.

JR05199.00006C2 -19-28MAR12-1/1

Contents

Section 00—General Information

- Group 0001—Safety
- Group 0003—Torque Values

Section 01—Wheels or Tracks

- Group 0110—Powered Wheels and Fastenings
- Group 0130—Track System

Section 02—Axles and Suspension Systems

- Group 0201—Drive Axle Housing and Support
- Group 0250—Axle Shaft, Bearings, and Reduction Gears

Section 03—Transmission

- Group 0315—Controls Linkage
- Group 0325—Flywheel Coupler
- Group 0360—Hydraulic System

Section 04—Engine

- Group 0400—Removal and Installation

Section 05—Engine Auxiliary System

- Group 0510—Cooling Systems
- Group 0520—Intake System
- Group 0530—External Exhaust Systems
- Group 0560—External Fuel Supply Systems

Section 17—Frame or Supporting Structure

- Group 1740—Frame Installation

Section 18—Operator's Station

- Group 1800—Removal and Installation
- Group 1810—Operator Enclosure
- Group 1821—Seat and Seat Belt
- Group 1830—Heating and Air Conditioning

Section 19—Sheet Metal and Styling

- Group 1910—Hood or Engine Enclosure

Section 20—Safety and Convenience

- Group 2001—Radio

Section 21—Main Hydraulic System

- Group 2160—Hydraulic System

Section 31—Loader

- Group 3104—Attachment Coupler
- Group 3140—Frame

Group 3160—Hydraulic System

Section 99—Dealer Fabricated Tools

Group 9900—Dealer Fabricated Tools

Original Instructions. All information, illustrations and specifications in this manual are based on the latest information available at the time of publication. The right is reserved to make changes at any time without notice.

COPYRIGHT © 2012
DEERE & COMPANY
Moline, Illinois
All rights reserved.
A John Deere ILLUSTRATION © Manual
Previous Editions
Copyright © 2010, 2011

Contents

Section 00 General Information

Contents

	Page		Page
Group 0001—Safety			
Recognize Safety Information	00-0001-1	Service Recommendations for 37° Flare and 30° Cone Seat Connectors	00-0003-6
Follow Safety Instructions.....	00-0001-1	Service Recommendations For Flared Connections—Straight or Tapered Threads	00-0003-7
Operate Only If Qualified	00-0001-1	Inch Series Four Bolt Flange Fitting For High Pressure Service Recommendations.....	00-0003-8
Wear Protective Clothing.....	00-0001-2	Service Recommendations For Inch Series Four Bolt Flange Fittings.....	00-0003-9
Avoid Unauthorized Machine Modifications.....	00-0001-2	Service Recommendation O-Ring Face Seal Fittings with Metric Hex Nut and Stud End for Standard Pressure.....	00-0003-10
Inspect Machine	00-0001-2	Service Recommendations for Metric Series Four Bolt Flange Fitting.....	00-0003-12
Stay Clear of Moving Parts.....	00-0001-2		
Avoid High-Pressure Fluids	00-0001-3		
Avoid High-Pressure Oils	00-0001-3		
Work In Ventilated Area.....	00-0001-4		
Prevent Fires	00-0001-4		
Prevent Battery Explosions	00-0001-5		
Handle Chemical Products Safely.....	00-0001-5		
Dispose of Waste Properly	00-0001-5		
Prepare for Emergencies.....	00-0001-6		
Clean Debris from Machine	00-0001-6		
Use Steps and Handholds Correctly	00-0001-6		
Start Only From Operator's Seat	00-0001-6		
Use and Maintain Seat Belt.....	00-0001-7		
Prevent Unintended Machine Movement.....	00-0001-7		
Avoid Work Site Hazards.....	00-0001-8		
Keep Riders Off Machine	00-0001-8		
Avoid Backover Accidents	00-0001-8		
Avoid Machine Tip Over	00-0001-9		
Operating On Slopes	00-0001-9		
Operating Or Traveling On Public Roads	00-0001-9		
Inspect and Maintain ROPS	00-0001-10		
Add and Operate Attachments Safely.....	00-0001-10		
Park and Prepare for Service Safely.....	00-0001-10		
Service Cooling System Safely	00-0001-11		
Remove Paint Before Welding or Heating	00-0001-11		
Make Welding Repairs Safely	00-0001-11		
Drive Metal Pins Safely	00-0001-12		
Service Tires Safely.....	00-0001-12		
Handle Cab Door Safely.....	00-0001-12		
Group 0003—Torque Values			
Unified Inch Bolt and Screw Torque Values.....	00-0003-1		
Metric Bolt and Screw Torque Values.....	00-0003-2		
Additional Metric Cap Screw Torque Values	00-0003-3		
Check Oil Lines And Fittings	00-0003-4		
Service Recommendations for O-Ring Boss Fittings.....	00-0003-4		

Contents

Recognize Safety Information

This is the safety alert symbol. When this symbol is noticed on the machine or in this manual, be alert for the potential of personal injury.

Follow the precautions and safe operating practices highlighted by this symbol.

A signal word — DANGER, WARNING, or CAUTION — is used with the safety alert symbol. DANGER identifies the most serious hazards.

On the machine, DANGER signs are red in color, WARNING signs are orange, and CAUTION signs are yellow. DANGER and WARNING signs are located near specific hazards. General precautions are on CAUTION labels.



TX03679,00016CC -19-03JAN07-1/1

T133555 —UN—28AUG00

T133568 —19—28AUG00

Follow Safety Instructions

Carefully read all safety messages in this manual and on your machine safety signs. Keep safety signs in good condition. Replace missing or damaged safety signs. Be sure new equipment components and repair parts include the current safety signs. Replacement safety signs are available from your John Deere dealer.

There can be additional safety information contained on parts and components sourced from suppliers that is not reproduced in this operator's manual.

Learn how to operate the machine and how to use controls properly. Do not let anyone operate without instruction.

Keep your machine in proper working condition. Unauthorized modifications to the machine may impair the function and/or safety and affect machine life.

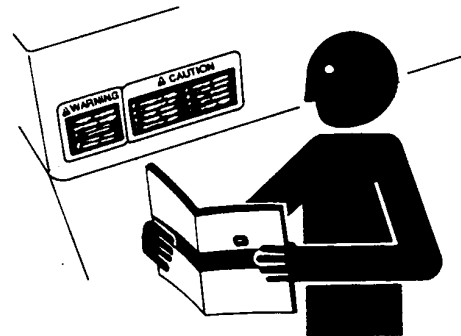

If you do not understand any part of this manual and need assistance, contact your John Deere dealer.

DX,READ -19-16JUN09-1/1

TS201 —UN—23AUG88

Operate Only If Qualified

Do not operate this machine unless the operator's manual has been read carefully, and you have been qualified by supervised training and instruction.

Operator should be familiar with the job site and surroundings before operating. Try all controls and

machine functions with the machine in an open area before starting to work.

Know and observe all safety rules that may apply to every work situation and work site.

TX03679,00016FA -19-03JAN07-1/1

Wear Protective Clothing

Wear close fitting clothing and safety equipment appropriate to the job.

Prolonged exposure to loud noise can cause impairment or loss of hearing.

Wear a suitable hearing protective device such as earmuffs or earplugs to protect against objectionable or uncomfortable loud noises.

Operating equipment safely requires the full attention of the operator. Do not wear radio or music headphones while operating machine.

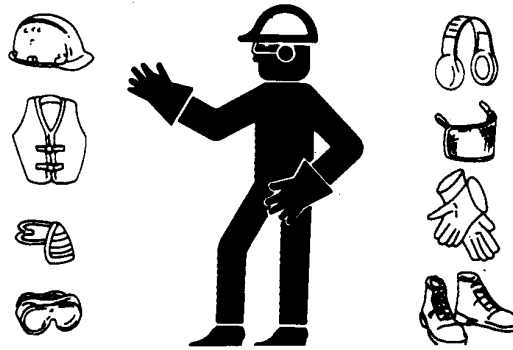

TS206—JUN—23AUG88

DX,WEAR -19-10SEP90-1/1

Avoid Unauthorized Machine Modifications

John Deere recommends using only genuine John Deere replacement parts to ensure machine performance. Never substitute genuine John Deere parts with alternate parts not intended for the application as these can create hazardous situations or hazardous performance. Non-John Deere parts, or any damage or failures resulting from their use are not covered by any John Deere warranty.

Modifications of this machine, or addition of unapproved products or attachments, may affect machine stability or

reliability, and may create a hazard for the operator or others near the machine. The installer of any modification which may affect the electronic controls of this machine is responsible for establishing that the modification does not adversely affect the machine or its performance.

Always contact an authorized dealer before making machine modifications that change the intended use, weight or balance of the machine, or that alter machine controls, performance or reliability.

AM40430,00000A9 -19-20AUG09-1/1

Inspect Machine

Inspect machine carefully each day by walking around it before starting.

Keep all guards and shields in good condition and properly installed. Fix damage and replace worn or broken parts immediately. Pay special attention to hydraulic hoses and electrical wiring.



T6607AQ—JUN—18OCT88

TX03679,0001734 -19-03JAN07-1/1

Stay Clear of Moving Parts

Entanglements in moving parts can cause serious injury.

Stop engine before examining, adjusting or maintaining any part of machine with moving parts.

Keep guards and shields in place. Replace any guard or shield that has been removed for access as soon as service or repair is complete.

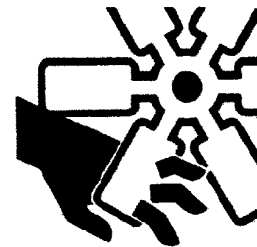

T133552—JUN—12SEP01

TX03679,00016D2 -19-03JAN07-1/1

Avoid High-Pressure Fluids

Inspect hydraulic hoses periodically – at least once per year – for leakage, kinking, cuts, cracks, abrasion, blisters, corrosion, exposed wire braid or any other signs of wear or damage.

Replace worn or damaged hose assemblies immediately with John Deere approved replacement parts.

Escaping fluid under pressure can penetrate the skin causing serious injury.

Avoid the hazard by relieving pressure before disconnecting hydraulic or other lines. Tighten all connections before applying pressure.

Search for leaks with a piece of cardboard. Protect hands and body from high-pressure fluids.

If an accident occurs, see a doctor immediately. Any fluid injected into the skin must be surgically removed within a few hours or gangrene may result. Doctors unfamiliar

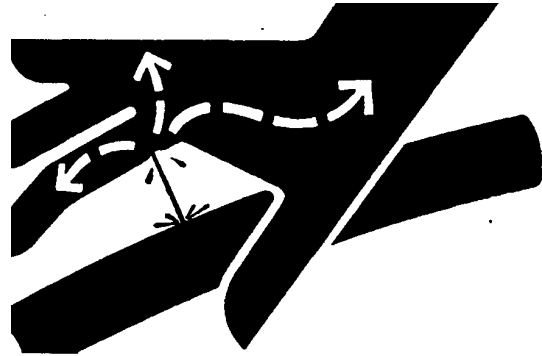

with this type of injury should reference a knowledgeable medical source. Such information is available in English from Deere & Company Medical Department in Moline, Illinois, U.S.A., by calling 1-800-822-8262 or +1 309-748-5636.

DX,FLUID -19-12OCT11-1/1

X8811 —UN—23AUG88

Avoid High-Pressure Oils

This machine uses a high-pressure hydraulic system. Escaping oil under pressure can penetrate the skin causing serious injury.

Never search for leaks with your hands. Protect hands. Use a piece of cardboard to find location of escaping oil. Stop engine and relieve pressure before disconnecting lines or working on hydraulic system.

If hydraulic oil penetrates your skin, see a doctor immediately. Injected oil must be removed surgically within hours or gangrene may result. Contact a knowledgeable medical source or the Deere & Company Medical Department in Moline, Illinois, U.S.A.

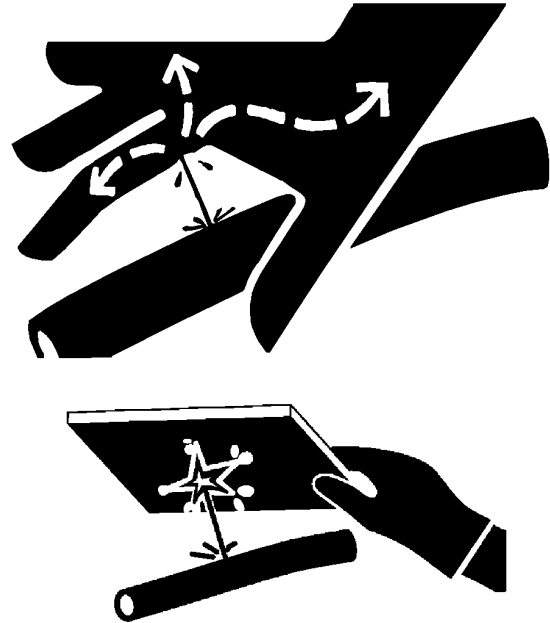

TX03679,00016D3 -19-03NOV08-1/1

T133509 —UN—17MAR06

T133840 —UN—20SEP00

Work In Ventilated Area

Engine exhaust fumes can cause sickness or death. If it is necessary to run an engine in an enclosed area, remove the exhaust fumes from the area with an exhaust pipe extension.

If you do not have an exhaust pipe extension, open the doors and get outside air into the area.

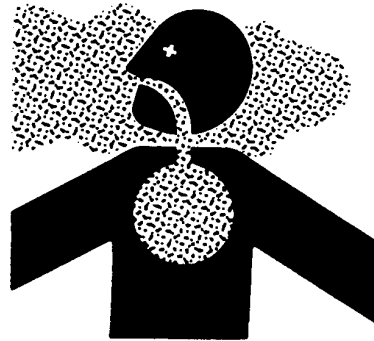

TS220—UN—23AUG88

DX,AIR -19-17FEB99-1/1

Prevent Fires

Handle Fuel Safely: Store flammable fluids away from fire hazards. Never refuel machine while smoking or when near sparks or flame.

Clean Machine Regularly: Keep trash, debris, grease and oil from accumulating in engine compartment, around fuel lines, hydraulic lines, exhaust components, and electrical wiring. Never store oily rags or flammable materials inside a machine compartment.

Maintain Hoses and Wiring: Replace hydraulic hoses immediately if they begin to leak, and clean up any oil spills. Examine electrical wiring and connectors frequently for damage.

Keep A Fire Extinguisher Available: Always keep a multipurpose fire extinguisher on or near the machine. Know how to use extinguisher properly.



T133553—UN—07SEP00



T133554—UN—07SEP00



T133552—UN—14SEP00

TX03679,00016F5 -19-03NOV08-1/1

Prevent Battery Explosions

Keep sparks, lighted matches, and open flame away from the top of battery. Battery gas can explode.

Never check battery charge by placing a metal object across the posts. Use a volt-meter or hydrometer.

Do not charge a frozen battery; it may explode. Warm battery to 16°C (60°F).



DX,SPARKS -19-03MAR93-1/1

TS204—UN—23AUG88

Handle Chemical Products Safely

Direct exposure to hazardous chemicals can cause serious injury. Potentially hazardous chemicals used with John Deere equipment include such items as lubricants, coolants, paints, and adhesives.

A Material Safety Data Sheet (MSDS) provides specific details on chemical products: physical and health hazards, safety procedures, and emergency response techniques.

Check the MSDS before you start any job using a hazardous chemical. That way you will know exactly what the risks are and how to do the job safely. Then follow procedures and recommended equipment.

(See your John Deere dealer for MSDS's on chemical products used with John Deere equipment.)



DX,MSDS,NA -19-03MAR93-1/1

TS1132—UN—26NOV90

Dispose of Waste Properly

Improperly disposing of waste can threaten the environment and ecology. Potentially harmful waste used with John Deere equipment include such items as oil, fuel, coolant, brake fluid, filters, and batteries.

Use leakproof containers when draining fluids. Do not use food or beverage containers that may mislead someone into drinking from them.

Do not pour waste onto the ground, down a drain, or into any water source.

Air conditioning refrigerants escaping into the air can damage the Earth's atmosphere. Government regulations may require a certified air conditioning service center to recover and recycle used air conditioning refrigerants.

Inquire on the proper way to recycle or dispose of waste from your local environmental or recycling center, or from your John Deere dealer.

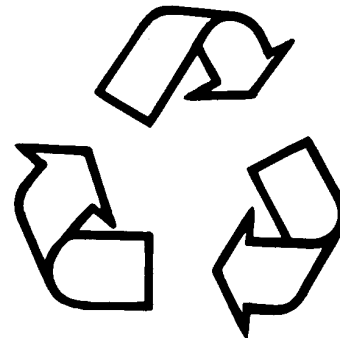

DX,DRAIN -19-03MAR93-1/1

TS1133—UN—26NOV90

Prepare for Emergencies

Be prepared if an emergency occurs or a fire starts.
 Keep a first aid kit and fire extinguisher handy.
 Keep emergency numbers for doctors, ambulance service, hospital, and fire department near your telephone.

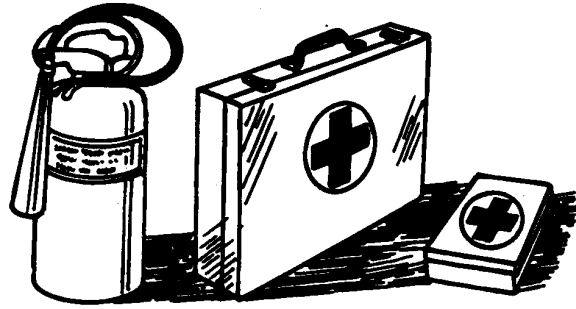

TS291 — UN — 23AUG88

TX03679,000174B -19-03NOV08-1/1

Clean Debris from Machine

Keep engine compartment, radiator, batteries, hydraulic lines, exhaust components, fuel tank, and operator's station clean and free of debris.

Clean any oil spills or fuel spills on machine surfaces.

Temperature in engine compartment may go up immediately after engine is stopped. **BE ON GUARD FOR FIRES DURING THIS PERIOD.**

Open access door(s) to cool the engine faster, and clean engine compartment.



T6669AG — UN — 18OCT88

OUT4001,00000E3 -19-20AUG09-1/1

Use Steps and Handholds Correctly

Prevent falls by facing the machine when getting on and off. Maintain 3-point contact with steps and handrails. Never use machine controls as handholds.

Use extra care when mud, snow, or moisture present slippery conditions. Keep steps clean and free of grease or oil. Never jump when exiting machine. Never mount or dismount a moving machine.

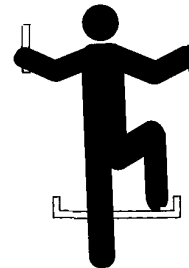

T133468 — UN — 30AUG00

TX03679,00016F2 -19-15MAR07-1/1

Start Only From Operator's Seat

Avoid unexpected machine movement. Start engine only while sitting in operator's seat. Ensure all controls and working tools are in proper position for a parked machine.

Never attempt to start engine from the ground. Do not attempt to start engine by shorting across the starter solenoid terminals.



T133715 — UN — 07SEP00

TX03679,0001799 -19-22APR10-1/1

Use and Maintain Seat Belt

Use seat belt when operating machine. Remember to fasten seat belt when loading and unloading from trucks and during other uses.

Examine seat belt frequently. Be sure webbing is not cut or torn. Replace seat belt immediately if any part is damaged or does not function properly.

The complete seat belt assembly should be replaced every 3 years, regardless of appearance.



USE SEAT BELT

T133716—19—14SEP00

TX03679,00016DD -19-03NOV08-1/1

Prevent Unintended Machine Movement

Be careful not to accidentally actuate controls. Follow these steps during work interruptions, before allowing coworkers to approach the machine, before standing up, leaving the operator's seat, or exiting the machine:

- Lower equipment to the ground
- Press park brake switch (1) to position P to engage park brake
- Stop the engine
- Raise interlocking seat bar

1— Park Brake Switch



TX1064905A—UN—23SEP09

OUT4001,0000467 -19-28SEP09-1/1

Avoid Work Site Hazards

Avoid contact with gas lines, buried cables, and water lines. Call utility line location services to identify all underground utilities before starting work.

Prepare work site properly. Avoid operating near structures or objects that could fall onto the machine. Clear away debris that could move unexpectedly if run over.

Avoid boom or attachment contact with overhead obstacles or overhead electrical lines. Never move machine closer than 3 m (10 ft) plus twice the line insulator length to overhead wires.

Keep bystanders clear at all times. Keep bystanders away from raised booms, attachments, and unsupported loads. Avoid swinging or raising booms, attachments, or loads over or near personnel. Use barricades or a signal person to keep vehicles and pedestrians away. Use a signal person if moving machine in congested areas or where visibility is restricted. Always keep signal person in view. Coordinate hand signals before starting machine.

Operate only on solid footing with strength sufficient to support machine. Be especially alert working near embankments or excavations.

Avoid working under over-hanging embankments or stockpiles that could collapse under or on machine.

Reduce machine speed when operating with tool on or near ground when obstacles may be hidden (e.g., during snow removal or clearing mud, dirt, etc.). At high speeds

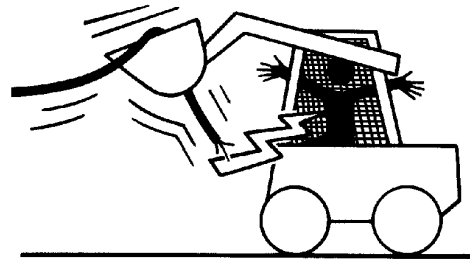

hitting obstacles (rocks, uneven concrete, or manholes) can cause a sudden stop. Always wear your seat belt. On units equipped with shoulder belts always wear both the seat and shoulder belt and **do not lean forward** while operating.

T192884 —UN—26AUG03

TX1064889 —UN—02OCT09

OUT4001,00004A4 -19-23SEP09-1/1

Keep Riders Off Machine

Only allow operator on machine.

Riders are subject to injury. They may fall from machine, be caught between machine parts, or be struck by foreign objects.

Riders may obstruct operator's view or impair his ability to operate machine safely.

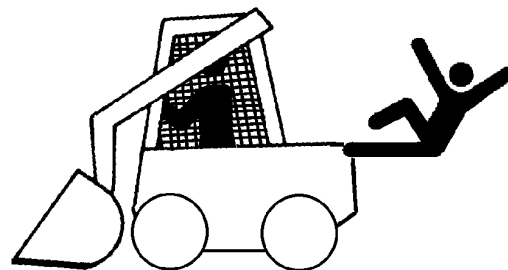

T192977 —UN—26AUG03

VD76477,0000094 -19-31JAN07-1/1

Avoid Backover Accidents

Before moving machine, be sure all persons or vehicles are clear of machine path. Turn around and look directly for best visibility. Keep windows clean.

Be certain reverse warning alarm is working properly (if equipped).

Use a signal person when backing if view is obstructed or when in close quarters. Keep signal person in view at all times. Use prearranged hand signals to communicate.



T192978 —UN—26AUG03

VD76477,0000095 -19-31JAN07-1/1

Avoid Machine Tip Over

Use seat belt at all times.

Do not jump if the machine tips. You will be unlikely to jump clear and the machine may crush you.

Load and unload from trucks or trailers carefully. Be sure truck is wide enough and on a firm level surface. Use loading ramps and attach them properly to truck bed.

Be careful on slopes. Avoid sharp turns. Balance loads so weight is evenly distributed and load is stable. Carry tools and loads close to the ground to aid visibility and lower center of gravity. Use extra care on wet, soft, rocky, or frozen ground.

Know the capacity of the machine. Do not overload. Be careful with heavy loads. Using oversize buckets or lifting heavy objects reduces machine stability.

Ensure solid footing. Use extra care in soft ground conditions or on structures that may not uniformly support the wheels especially when raising the boom. Do not operate close to banks or open excavations that may cave in and cause machine to tip or fall.



**USE
SEAT
BELT**

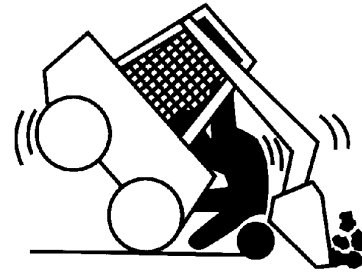

VD76477,0000096 -19-20MAR07-1/1

T133716 —19—14SEP00

T192979 —UN—26AUG03

Operating On Slopes

Avoid side slope travel whenever possible. When working on steep slopes, travel as straight up and down as possible and keep the heavy end of the vehicle uphill to prevent machine tip over.

Carry the load as low as possible for maximum stability and visibility.

Select low speed before starting down slope. The slope on which you can operate safely will be limited by ground condition and the load being handled.

Be alert to wind direction and velocity.



OUT4001,0000470 -19-28AUG09-1/1

TX1063677 —UN—01SEP09

Operating Or Traveling On Public Roads

Machines that work near vehicle traffic or travel slower than normal highway speeds must have proper lighting and markings to assure they are visible to other drivers.

Install additional lights, beacons, slow moving vehicle (SMV) emblems, or other devices and use as required to make the machine visible and identify it as a work machine. Check state and local regulations to assure compliance. Keep these devices clean and in working condition.

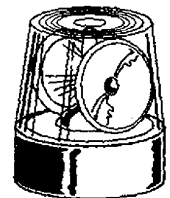
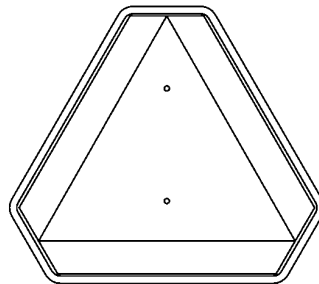

TX03679,00017C8 -19-14JUN01-1/1

T141891 —UN—22MAY01

Inspect and Maintain ROPS

A damaged roll-over protective structure (ROPS) should be replaced, not reused.

The protection offered by ROPS will be impaired if ROPS is subjected to structural damage, is involved in an overturn incident, or is in any way altered by welding, bending, drilling, or cutting.

If ROPS was loosened or removed for any reason, inspect it carefully before operating the machine again.

To maintain the ROPS:

- Replace missing hardware using correct grade hardware.
- Check hardware torque.
- Check isolation mounts for damage, looseness or wear; replace them if necessary.
- Check ROPS for cracks or physical damage.

TX03679,000179F -19-20APR01-1/1

Add and Operate Attachments Safely

Always verify compatibility of attachments by contacting your authorized dealer. Adding unapproved attachments may affect machine stability or reliability, and may create a hazard for others near the machine.

Ensure that a qualified person is involved in attachment installation. Add guards to machine if operator protection

is required or recommended. Verify that all connections are secure and attachment responds properly to controls.

Carefully read attachment manual and follow all instructions and warnings. In an area free of bystanders and obstructions, carefully operate attachment to learn its characteristics and range of motion.

TX03679,00016F0 -19-24JAN07-1/1

Park and Prepare for Service Safely

Warn others of service work. Always park and prepare machine for service or repair properly.

- Park machine on a level surface and lower equipment to the ground.
- Engage park brake.
- Stop engine and remove key.
- Attach a "DO NOT OPERATE" tag in an obvious place in the operator's station.

Securely support machine or attachment before working under it.

- Do not support machine with any hydraulically actuated tools or attachments.
- Do not support machine with cinder blocks or wooden pieces that may crumble or crush.
- Do not support machine with a single jack or other devices that may slip out of place.
- Always install boom lock before working on or around this machine with the loader boom raised.

Understand service procedures before beginning repairs. Keep service area clean and dry. Use two people whenever the engine must be running for service work.

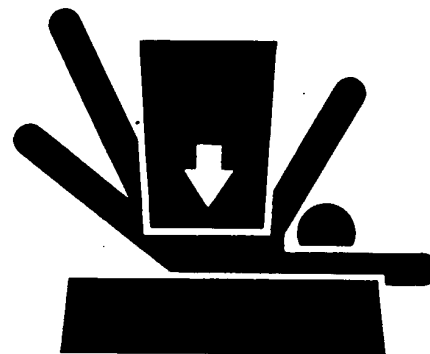
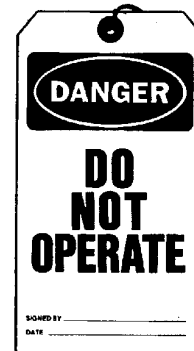

T133332 —19—14DEC01

TS229 —JUN—23AUG88

DW90712,00001D1 -19-21AUG09-1/1

Service Cooling System Safely

Explosive release of fluids from pressurized cooling system can cause serious burns.

Shut off engine. Only remove filler cap when cool enough to touch with bare hands. Slowly loosen cap to first stop to relieve pressure before removing completely.

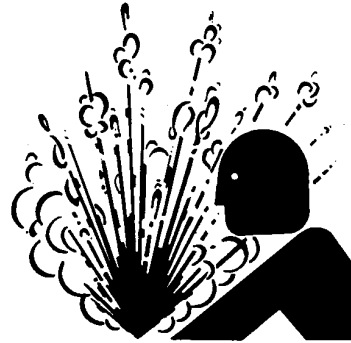

DX,RCAP -19-04JUN90-1/1

TS281—UN—23AUG88

Remove Paint Before Welding or Heating

Avoid potentially toxic fumes and dust.

Hazardous fumes can be generated when paint is heated by welding, soldering, or using a torch.

Remove paint before heating:

- Remove paint a minimum of 100 mm (4 in.) from area to be affected by heating. If paint cannot be removed, wear an approved respirator before heating or welding.
- If you sand or grind paint, avoid breathing the dust. Wear an approved respirator.
- If you use solvent or paint stripper, remove stripper with soap and water before welding. Remove solvent or paint stripper containers and other flammable material from area. Allow fumes to disperse at least 15 minutes before welding or heating.

Do not use a chlorinated solvent in areas where welding will take place.

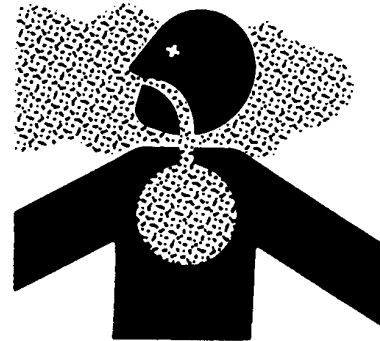

Do all work in an area that is well ventilated to carry toxic fumes and dust away.

Dispose of paint and solvent properly.

DX,PAINT -19-24JUL02-1/1

TS220—UN—23AUG88

Make Welding Repairs Safely

IMPORTANT: Disable electrical power before welding. Turn off main battery switch or disconnect positive battery cable. Separate harness connectors to engine and vehicle microprocessors.

Avoid welding or heating near pressurized fluid lines. Flammable spray may result and cause severe burns if pressurized lines fail as a result of heating. Do not let heat go beyond work area to nearby pressurized lines.

Remove paint properly. Do not inhale paint dust or fumes. Use a qualified welding technician for structural repairs.



Make sure there is good ventilation. Wear eye protection and protective equipment when welding.

TX03679,00016D5 -19-31AUG07-1/1

T133547—UN—31AUG00

Drive Metal Pins Safely

Always wear protective goggles or safety glasses and other protective equipment before striking hardened parts. Hammering hardened metal parts such as pins and bucket teeth may dislodge chips at high velocity.

Use a soft hammer or a brass bar between hammer and object to prevent chipping.

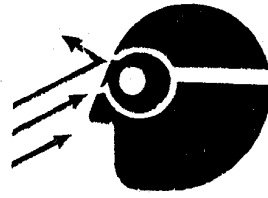

TI133738 —UN—14SEP00

TX03679,0001745 -19-25SEP00-1/1

Service Tires Safely

Explosive separation of a tire and rim parts can cause serious injury or death.

Do not attempt to mount a tire unless you have the proper equipment and experience to perform the job.

Always maintain the correct tire pressure. Do not inflate the tires above the recommended pressure. Never weld or heat a wheel and tire assembly. The heat can cause an increase in air pressure resulting in a tire explosion. Welding can structurally weaken or deform the wheel.

When inflating tires, use a clip-on chuck and extension hose long enough to allow you to stand to one side and NOT in front of or over the tire assembly. Use a safety cage if available.

Check wheels for low pressure, cuts, bubbles, damaged rims or missing lug bolts and nuts.

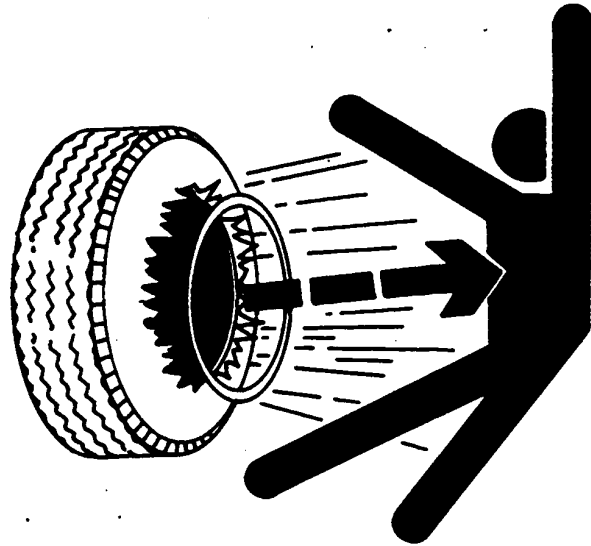

TIS211 —UN—23AUG88

DX,RIM -19-24AUG90-1/1

Handle Cab Door Safely

When servicing machine, be aware that cab door (1) is breakable.

Keep door closed if cab needs to be raised for service. Be aware of surroundings so that door does not come in contact with any objects.

Use care if cab door needs to be removed. To prevent damage to the door, handle with care and store in a secure location.

1— Cab Door



TX1063683A —UN—08SEP09

OUT4001,0000472 -19-28OCT09-1/1

Group 0003 Torque Values

Unified Inch Bolt and Screw Torque Values

TS1671 —UN—01MAY03

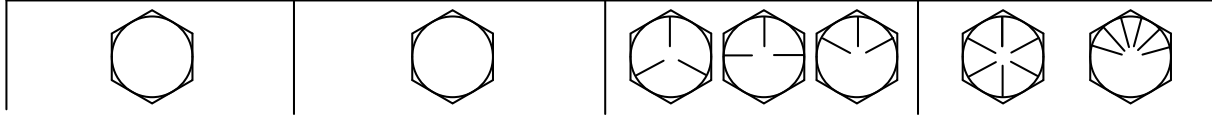

Bolt or Screw Size	SAE Grade 1				SAE Grade 2 ^a				SAE Grade 5, 5.1 or 5.2				SAE Grade 8 or 8.2			
	Lubricated ^b		Dry ^c		Lubricated ^b		Dry ^c		Lubricated ^b		Dry ^c		Lubricated ^b		Dry ^c	
	N-m	lb.-in.	N-m	lb.-in.	N-m	lb.-in.	N-m	lb.-in.	N-m	lb.-in.	N-m	lb.-in.	N-m	lb.-in.	N-m	lb.-in.
1/4	3.7	33	4.7	42	6	53	7.5	66	9.5	84	12	106	13.5	120	17	150
													N-m	lb.-ft.	N-m	lb.-ft.
5/16	7.7	68	9.8	86	12	106	15.5	137	19.5	172	25	221	28	20.5	35	26
									N-m	lb.-ft.	N-m	lb.-ft.				
3/8	13.5	120	17.5	155	22	194	27	240	35	26	44	32.5	49	36	63	46
			N-m	lb.-ft.	N-m	lb.-ft.	N-m	lb.-ft.								
7/16	22	194	28	20.5	35	26	44	32.5	56	41	70	52	80	59	100	74
	N-m	lb.-ft.														
1/2	34	25	42	31	53	39	67	49	85	63	110	80	120	88	155	115
9/16	48	35.5	60	45	76	56	95	70	125	92	155	115	175	130	220	165
5/8	67	49	85	63	105	77	135	100	170	125	215	160	240	175	305	225
3/4	120	88	150	110	190	140	240	175	300	220	380	280	425	315	540	400
7/8	190	140	240	175	190	140	240	175	490	360	615	455	690	510	870	640
1	285	210	360	265	285	210	360	265	730	540	920	680	1030	760	1300	960
1-1/8	400	300	510	375	400	300	510	375	910	670	1150	850	1450	1075	1850	1350
1-1/4	570	420	725	535	570	420	725	535	1280	945	1630	1200	2050	1500	2600	1920
1-3/8	750	550	950	700	750	550	950	700	1700	1250	2140	1580	2700	2000	3400	2500
1-1/2	990	730	1250	930	990	730	1250	930	2250	1650	2850	2100	3600	2650	4550	3350

Torque values listed are for general use only, based on the strength of the bolt or screw. DO NOT use these values if a different torque value or tightening procedure is given for a specific application. For plastic insert or crimped steel type lock nuts, for stainless steel fasteners, or for nuts on U-bolts, see the tightening instructions for the specific application. Shear bolts are designed to fail under predetermined loads. Always replace shear bolts with identical grade.

Replace fasteners with the same or higher grade. If higher grade fasteners are used, tighten these to the strength of the original. Make sure fastener threads are clean and that you properly start thread engagement. When possible, lubricate plain or zinc plated fasteners other than lock nuts, wheel bolts or wheel nuts, unless different instructions are given for the specific application.

^aGrade 2 applies for hex cap screws (not hex bolts) up to 6 in. (152 mm) long. Grade 1 applies for hex cap screws over 6 in. (152 mm) long, and for all other types of bolts and screws of any length.

^b"Lubricated" means coated with a lubricant such as engine oil, fasteners with phosphate and oil coatings, or 7/8 in. and larger fasteners with JDM F13C, F13F or F13J zinc flake coating.

^c"Dry" means plain or zinc plated without any lubrication, or 1/4 to 3/4 in. fasteners with JDM F13B, F13E or F13H zinc flake coating.

DX,TORQ1 -19-12JAN11-1/1

Torque Values

Metric Bolt and Screw Torque Values

TS1670 —UN—01MAY03

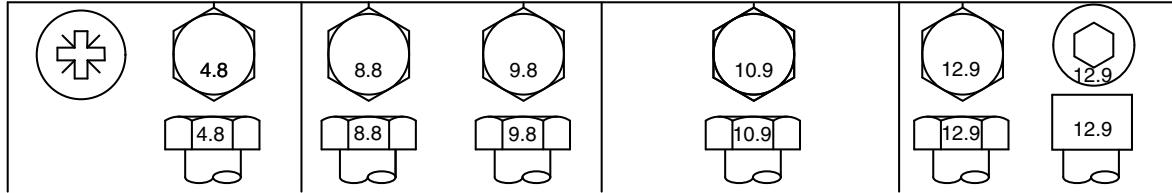

Bolt or Screw Size	Class 4.8				Class 8.8 or 9.8				Class 10.9				Class 12.9			
	Lubricated ^a		Dry ^b		Lubricated ^a		Dry ^b		Lubricated ^a		Dry ^b		Lubricated ^a		Dry ^b	
	N·m	lb.-in.	N·m	lb.-in.	N·m	lb.-in.	N·m	lb.-in.	N·m	lb.-in.	N·m	lb.-in.	N·m	lb.-in.	N·m	lb.-in.
M6	4.7	42	6	53	8.9	79	11.3	100	13	115	16.5	146	15.5	137	19.5	172
M8	11.5	102	14.5	128	22	194	27.5	243	N·m	lb.-ft.	N·m	lb.-ft.	N·m	lb.-ft.	N·m	lb.-ft.
									32	23.5	40	29.5	37	27.5	47	35
M10	23	204	29	21	43	32	55	40	63	46	80	59	75	55	95	70
	N·m	lb.-ft.														
M12	40	29.5	50	37	75	55	95	70	110	80	140	105	130	95	165	120
M14	63	46	80	59	120	88	150	110	175	130	220	165	205	150	260	190
M16	100	74	125	92	190	140	240	175	275	200	350	255	320	235	400	300
M18	135	100	170	125	265	195	330	245	375	275	475	350	440	325	560	410
M20	190	140	245	180	375	275	475	350	530	390	675	500	625	460	790	580
M22	265	195	330	245	510	375	650	480	725	535	920	680	850	625	1080	800
M24	330	245	425	315	650	480	820	600	920	680	1150	850	1080	800	1350	1000
M27	490	360	625	460	950	700	1200	885	1350	1000	1700	1250	1580	1160	2000	1475
M30	660	490	850	625	1290	950	1630	1200	1850	1350	2300	1700	2140	1580	2700	2000
M33	900	665	1150	850	1750	1300	2200	1625	2500	1850	3150	2325	2900	2150	3700	2730
M36	1150	850	1450	1075	2250	1650	2850	2100	3200	2350	4050	3000	3750	2770	4750	3500

Torque values listed are for general use only, based on the strength of the bolt or screw. DO NOT use these values if a different torque value or tightening procedure is given for a specific application. For stainless steel fasteners or for nuts on U-bolts, see the tightening instructions for the specific application. Tighten plastic insert or crimped steel type lock nuts by turning the nut to the dry torque shown in the chart, unless different instructions are given for the specific application.

Shear bolts are designed to fail under predetermined loads. Always replace shear bolts with identical property class. Replace fasteners with the same or higher property class. If higher property class fasteners are used, tighten these to the strength of the original. Make sure fastener threads are clean and that you properly start thread engagement. When possible, lubricate plain or zinc plated fasteners other than lock nuts, wheel bolts or wheel nuts, unless different instructions are given for the specific application.

^a"Lubricated" means coated with a lubricant such as engine oil, fasteners with phosphate and oil coatings, or M20 and larger fasteners with JDM F13C, F13F or F13J zinc flake coating.

^b"Dry" means plain or zinc plated without any lubrication, or M6 to M18 fasteners with JDM F13B, F13E or F13H zinc flake coating.

DX,TORQ2 -19-12JAN11-1/1

Additional Metric Cap Screw Torque Values

⚠ CAUTION: Use only metric tools on metric hardware. Other tools may not fit properly. They may slip and cause injury.

Check tightness of cap screws periodically. Torque values listed are for general use only. Do not use these values if a different torque value or tightening procedure is listed for a specific application.

Shear bolts are designed to fail under predetermined loads. Always replace shear bolts with identical grade.

Fasteners should be replaced with the same or higher grade. If higher grade fasteners are used, these should only be tightened to the strength of the original.

Make sure fastener threads are clean and you properly start thread engagement. This will prevent them from failing when tightening.

Tighten cap screws having lock nuts to approximately 50 percent of amount shown in chart.

METRIC CAP SCREW TORQUE VALUES ^a						
Nominal Dia	T-Bolt		H-Bolt		M-Bolt	
	N-m	lb-ft	N-m	lb-ft	N-m	lb-ft
8	29	21	20	15	10	7
10	63	46	45	33	20	15
12	108	80	88	65	34	25
14	176	130	137	101	54	40
16	265	195	206	152	78	58
18	392	289	294	217	118	87
20	539	398	392	289	167	125
22	735	542	539	398	216	159
24	931	687	686	506	274	202
27	1372	1012	1029	759	392	289
30	1911	1410	1421	1049	539	398
33	2548	1890	1911	1410	735	542
36	3136	2314	2401	1772	931	687

^aTorque tolerance is ±10%.

T6873AA



T6873AB



T6873AC



T6873AA—UN—18OCT88

T6873AB—UN—18OCT88

T6873AC—UN—18OCT88

Check Oil Lines And Fittings

⚠ CAUTION: Escaping fluid under pressure can penetrate the skin causing serious injury. Avoid the hazard by relieving pressure before disconnecting hydraulic or other lines. Tighten all connections before applying pressure. Search for leaks with a piece of cardboard. Protect hands and body from high pressure fluids.

If an accident occurs, see a doctor immediately. Any fluid injected into the skin must be surgically removed within a few hours or gangrene may result. Doctors unfamiliar with this type of injury may call the Deere & Company Medical Department in Moline, Illinois, or other knowledgeable medical source.

Check all oil lines, hoses, and fittings regularly for leaks or damage. Make sure all clamps are in position and tight. Make sure hoses are not twisted or touching moving machine parts. If abrasion or wear occurs, replace immediately.

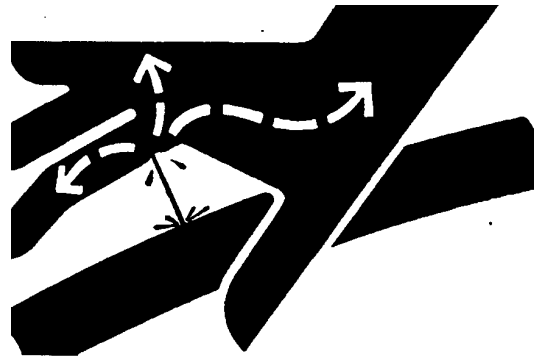

X9811 —UN—23AUG88

Tubing with dents may cause the oil to overheat. If you find tubing with dents, install new tubing immediately.

IMPORTANT: Tighten fittings as specified in torque chart.

When you tighten connections, use two wrenches to prevent bending or breaking tubing and fittings.

TX,90,DH1559 -19-01AUG94-1/1

Service Recommendations for O-Ring Boss Fittings

Straight Fitting

1. Inspect O-ring boss seat for dirt or defects.
2. Lubricate O-ring with petroleum jelly. Place electrical tape over threads to protect O-ring. Slide O-ring over tape and into O-ring groove of fitting. Remove tape.
3. Tighten fitting to torque value shown on chart.

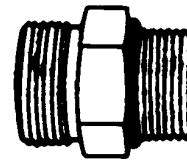

T6243AE —UN—18OCT88

Continued on next page

04T,90,K66 -19-29SEP99-1/2

Angle Fitting

1. Back-off lock nut (A) and back-up washer (B) completely to head-end (C) of fitting.
2. Turn fitting into threaded boss until back-up washer contacts face of boss.
3. Turn fitting head-end counterclockwise to proper index (maximum of one turn).

NOTE: Do not allow hoses to twist when tightening fittings.

4. Hold fitting head-end with a wrench and tighten locknut and back-up washer to proper torque value.

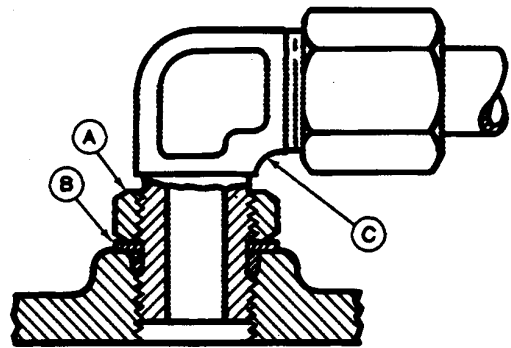

T6520AB—UN—18OCT88

STRAIGHT FITTING OR SPECIAL NUT TORQUE CHART

Thread Size	N-m	lb-ft
3/8-24 UNF	8	6
7/16-20 UNF	12	9
1/2-20 UNF	16	12
9/16-18 UNF	24	18
3/4-16 UNF	46	34
7/8-14 UNF	62	46
1-1/16-12 UN	102	75
1-3/16-12 UN	122	90
1-5/16-12 UN	142	105
1-5/8-12 UN	190	140
1-7/8-12 UN	217	160

NOTE: Torque tolerance is ± 10%.

04T,90,K66 -19-29SEP99-2/2

Service Recommendations for 37° Flare and 30° Cone Seat Connectors

1. Inspect flare and flare seat. They must be free of dirt or obvious defects.
2. Defects in tube flare cannot be repaired. Overtightening a defective flared fitting will not stop leaks.
3. Align tube with fitting before attempting to start nut.
4. Lubricate male threads with hydraulic fluid or petroleum jelly.
5. Index angle fittings and tighten by hand.
6. Tighten fitting or nut to torque value shown on torque chart. Do not allow hoses to twist when tightening fittings.

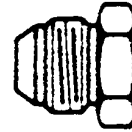

T6234AC—UN—18OCT88

STRAIGHT FITTING OR SPECIAL NUT TORQUE CHART		
Thread Size	N·m	lb·ft
3/8 - 24 UNF	8	6
7/16 - 20 UNF	12	9
1/2 - 20 UNF	16	12
9/16 - 18 UNF	24	18
3/4 - 16 UNF	46	34
7/8 - 14 UNF	62	46
1-1/16 - 12 UN	102	75
1-3/16 - 12 UN	122	90
1-5/16 - 12 UN	142	105
1-5/8 - 12	190	140
1-7/8 - 12 UN	217	160

NOTE: Torque tolerance is $\pm 10\%$.

T82,BHMA,EL -19-29SEP99-1/1

Service Recommendations For Flared Connections—Straight or Tapered Threads

1. Inspect flare and flare seat. They must be free of dirt or obvious defects.
2. Defects in the tube flare cannot be repaired. Overtightening a defective flared fitting will not stop leaks.
3. Align the tube with the fitting before attempting to start the nut.
4. Lubricate the male threads with hydraulic fluid or petroleum jelly.
5. Index angle fittings and tighten by hand.
6. Tighten fitting or nut to torque value shown on the chart. Do not allow hoses to twist when tightening fittings.

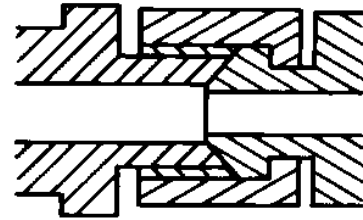

T6873AE

Straight Thread

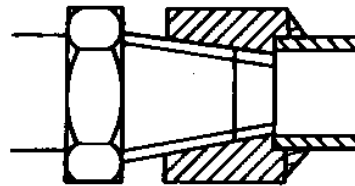

T6873AD

Tapered Thread

TORQUE CHART ^a

Thread Size	Straight Thread ^b		Tapered Thread	
	N·m	lb-ft	N·m	lb-ft
1/8	15	11		
1/4	20	15	45	33
3/8	29	21	69	51
1/2	49	36	93	69
3/4	69	51	176	130
1	157	116	343	253
1-1/2	196	145	539	398
2	255	188	588	434

^aTorque tolerance is $\pm 10\%$.

^bWith seat face.

NOTE: If female thread is cast iron (control valves, brake valves motors, etc.), torque must be reduced approximately 10%.

Inch Series Four Bolt Flange Fitting For High Pressure Service Recommendations

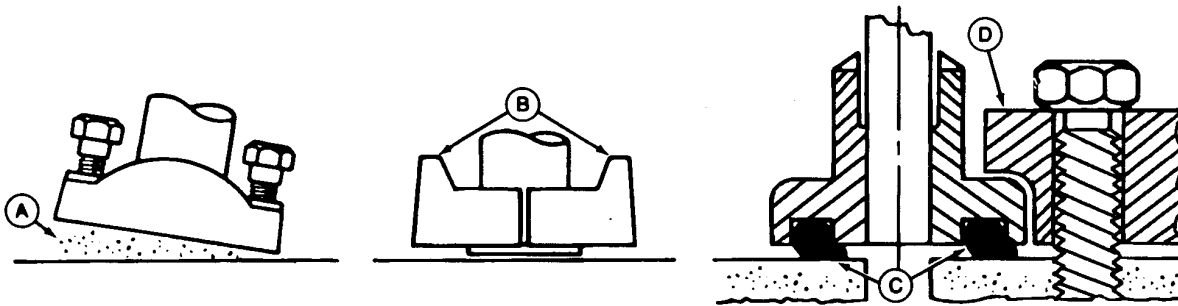

T6890BB—UN—01MAR90

A—Sealing Surface

B—Split Flange

C—Pinched O-Ring

D—Single Piece Flange

INCH SERIES FOUR BOLT FLANGE FITTING FOR 41 400 kPa (414 bar) (6000 psi) PRESSURE SERIES TORQUE VALUES—Tolerance is ± 10% unless otherwise specified

Nominal Flange Size	Cap Screw Size ^a	Min—Max Torque
in.	in.	Nm (lb-ft) ^b
1/2	5/16-18 UNC	20—31 (15—23)
3/4	3/8-16 UNC	34—54 (25—40)
1	7/16-14 UNC	57—85 (42—63)
1-1/4	1/2-13 UNC	85—131 (63—97)
1-1/2	5/8-11 UNC	159—264 (117—195)
2	3/4-10 UNC	271—468 (200—345)

^a JDM A17D, SAE Grade 5 or better cap screws with plated hardware. Lock washers are permissible but not recommended.

^b Minimum torques given are enough for the given size connection with the recommended working pressure. Torques can be increased to the maximum shown for each cap screw size if desired. Increasing cap screw torque beyond the maximum will result in flange and cap screw bending and connection failures.

1. Clean sealing surfaces (A). Inspect. Scratches, nicks, and burrs cause leaks. Roughness causes O-ring wear. Out-of-flat causes O-ring extrusion.

If imperfection cannot be polished out, replace component.

2. Install the O-ring (and backup ring, if used) into groove. Use petroleum jelly to hold it in place.

IMPORTANT: DO NOT use air wrenches. DO NOT tighten one cap screw fully before tightening the others. DO NOT over tighten.

3. Split flange: Loosely assemble split flange (B) halves. Make sure split is centrally located and perpendicular to port. Hand tighten cap screws to hold flange halves and line in place. Do not pinch O-ring (C).

Single piece flange (D): Make sure flange is centrally located on port and line is centered in flange. Install the cap screws. Hand tighten cap screws to hold flange and line in place. Do not pinch O-ring.

4. Tighten one cap screw and then the diagonally opposite cap screw. Tighten the two remaining cap screws. Tighten cap screws within the specified torque values.

OUT3035,0000422 -19-05MAR09-1/1

Service Recommendations For Inch Series Four Bolt Flange Fittings

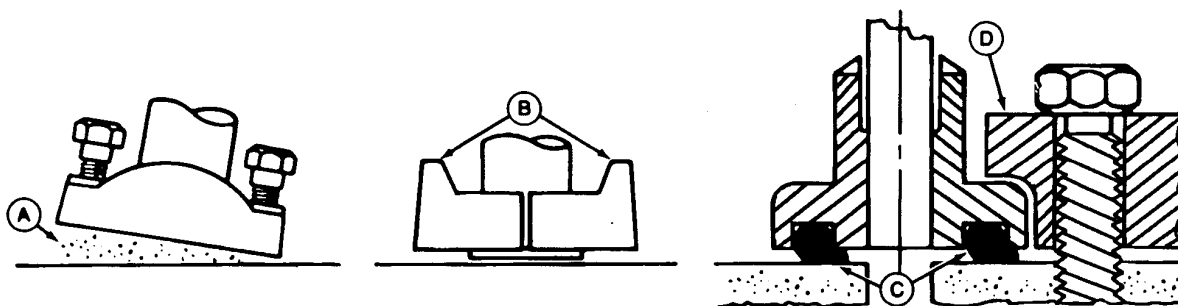

A—Sealing Surface

B—Split Flange

C—Pinched O-Ring

D—Single Piece Flange

1. Clean sealing surfaces (A). Inspect. Scratches cause leaks. Roughness causes seal wear. Out-of-flat causes seal extrusion. If defects cannot be polished out, replace component.
2. Install O-ring (and backup washer if required) into groove using petroleum jelly to hold it in place.
3. Split flange: Loosely assemble split flange (B) halves. Make sure split is centrally located and perpendicular to port. Hand tighten cap screws to hold parts in place. Do not pinch O-ring (C).
4. Single piece flange (D): Place hydraulic line in center of flange and install cap screws. Flange must be centrally located on port. Hand tighten cap screws to hold flange in place. Do not pinch O-ring.
5. Tighten one cap screw, then tighten the diagonally opposite cap screw. Tighten two remaining cap screws. Tighten all cap screws as specified in the chart below.

DO NOT use air wrenches. DO NOT tighten one cap screw fully before tightening the others. DO NOT over tighten.

TORQUE CHART					
Nominal Flange Size	Cap Screw Size	N-m		lb-ft	
		Min	Max	Min	Max
1/2	5/16-18 UNC	20	31	15	23
3/4	3/8-16 UNC	28	54	21	40
1	3/8-16 UNC	37	54	27	40
1-1/4	7/16-14 UNC	47	85	35	63
1-1/2	1/2-13 UNC	62	131	46	97
2	1/2-13 UNC	73	131	54	97
2-1/2	1/2-13 UNC	107	131	79	97
3	5/8-11 UNC	158	264	117	195
3-1/2	5/8-11 UNC	158	264	117	195
4	5/8-11 UNC	158	264	117	195
5	5/8-11 UNC	158	264	117	195

T6890BB—UN—01MAR90

04T,90,K174 -19-01AUG94-1/1

O-Ring Face Seal Fittings With Metric Hex Nut And Stud End For Standard Pressure Service Recommendations

O-RING FACE SEAL AND FITTINGS WITH METRIC HEX NUT AND STUD END FOR STANDARD PRESSURE, BELOW 27 600 kPa (275.8 bar) (4,000 psi), TORQUE VALUES—Tolerance is +15 -20% unless otherwise specified

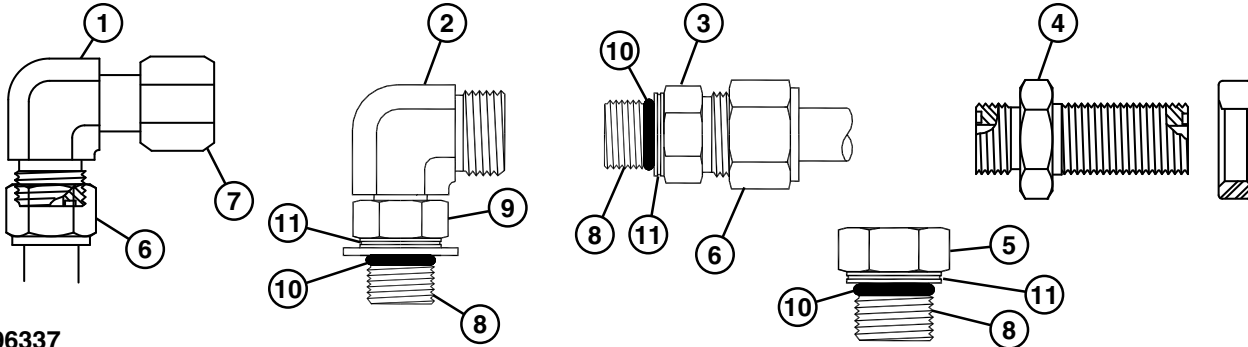

T196337

- 1— 90° Swivel Elbow
- 2— 90° Adjustable Stud Elbow
- 3— Stud Straight
- 4— Bulkhead Union and Nut
- 5— External Hex Stud End Plug
- 6— Tube Nut
- 7— Swivel Nut
- 8— Stud End
- 9— Hex Nut
- 10— O-Ring
- 11— Identification Groove

Nominal Tube OD or Hose ID			O-Ring Face Seal Hose or Tube Swivel Nut			Bulkhead Nut	
Metric Tube OD	Inch Tube OD or Hose ID		Thread Size	Hex Size	Torque	Hex Size	Torque
mm	Dash Size	mm (in.)	in.	mm	Nm (lb-ft)	mm	Nm (lb-ft)
4	-2	3.18 (0.125)	—	—	—	—	—
5	-3	4.78 (0.188)	—	—	—	—	—
6	-4	6.35 (0.250)	9/16-18	17	16 (12)	22	32 (24)
8	-5	7.92 (0.312)	—	—	—	—	—
10	-6	9.53 (0.375)	11/16-16	22	24 (18)	27	42 (31)
12	-8	12.70 (0.500)	13/16-16	24	50 (37)	30	93 (69)
16	-10	15.88 (0.625)	1-14	30	69 (51)	36	118 (87)
20	-12	19.05 (0.750)	1-3/16-12	36	102 (75)	41	175 (129)
22	-14	22.23 (0.875)	1-3/16-12	36	102 (75)	41	175 (129)
25	-16	25.40 (1.000)	1-7/16-12	41	142 (105)	46	247 (182)
28	—	—	—	—	—	—	—
32	-20	31.75 (1.250)	1-11/16-12	50	190 (140)	50	328 (242)
38	-24	38.10 (1.500)	2-12	60	217 (160)	60	374 (276)
50	-32	50.80 (2.000)	—	—	—	—	—

O-RING STRAIGHT, ADJUSTABLE, AND EXTERNAL HEX PLUG WITH METRIC STUD END FOR STANDARD PRESSURE, BELOW 27 600 kPa (275.8 bar) (4,000 psi), TORQUE VALUES—Tolerance is +15 -20% unless otherwise specified

Thread Size ^a	Straight Hex Size ^b	Adjustable Nut Hex Size	Steel or Gray Iron Torque	Aluminum or Brass Torque
mm.	mm	mm	Nm (lb-ft)	Nm (lb-ft)
M8 x 1	12	12	8 (6)	5 (4)
M10 x 1	14	14	15 (11)	10 (7)
M12 x 1.5	17	17	25 (18)	17 (12)
M14 x 1.5	19	19	40 (30)	27 (20)
M16 x 1.5	22	22	45 (33)	30 (22)
M18 x 1.5	24	24	50 (37)	33 (25)
M22 x 1.5	27	27	69 (51)	46 (34)
M27 x 2	32	32	100 (74)	67 (49)
M30 x 2	36	36	130 (96)	87 (64)
M33 x 2	41	41	160 (118)	107 (79)
M38 x 2	46	46	176 (130)	117 (87)
M42 x 2	50	50	210 (155)	140 (103)

Continued on next page

OUT3035,0000366 -19-28MAY09-1/2

T196337 —UN—18NOV03

Torque Values

O-RING STRAIGHT, ADJUSTABLE, AND EXTERNAL HEX PLUG WITH METRIC STUD END FOR STANDARD PRESSURE, BELOW 27 600 kPa (275.8 bar) (4,000 psi), TORQUE VALUES—Tolerance is +15 -20% unless otherwise specified

Thread Size ^a	Straight Hex Size ^b	Adjustable Nut Hex Size	Steel or Gray Iron Torque	Aluminum or Brass Torque
mm.	mm	mm	Nm (lb-ft)	Nm (lb-ft)
M48 x 2	55	55	260 (192)	173 (128)
M60 x 2	65	65	315 (232)	210 (155)

^a Stud end threads are identified as metric by an identification groove in the hex nut next to the O-ring.

^b Straight hex size applies to fittings only and may not be the same as the corresponding plug of the same thread size.

1. Inspect fitting and connector sealing surfaces and the O-rings. They must be free of dirt, scratches, nicks, and burrs. O-ring must be free of dirt, cuts, cracks, swelling or flatten condition.
2. Back the stud end hex nut off as far as possible. Push backup washer towards the nut to fully expose the turn down section. Washer must fit turned down section and not be too loose
3. Lubricate O-rings using a thin film of clean hydraulic oil or as needed, petroleum jelly to hold O-ring in place.

Install O-ring into groove making sure it is seated at the bottom. Excess petroleum jelly will prevent seating of O-ring and cause it to pop out.
4. Turn fitting into the boss by hand until face of nut or washer squeezes the O-ring into the seat and contacts face of boss. Loosen adjustable fittings no more than one turn for alignment.

Hold connections together while tightening nut to ensure O-ring remains in place.
5. Tighten fitting or nut to torque value shown. Use a second wrench to hold the fitting in position or to keep hose from twisting while tightening nut.

OUT3035.0000366 -19-28MAY09-2/2

Service Recommendations for Metric Series Four Bolt Flange Fitting

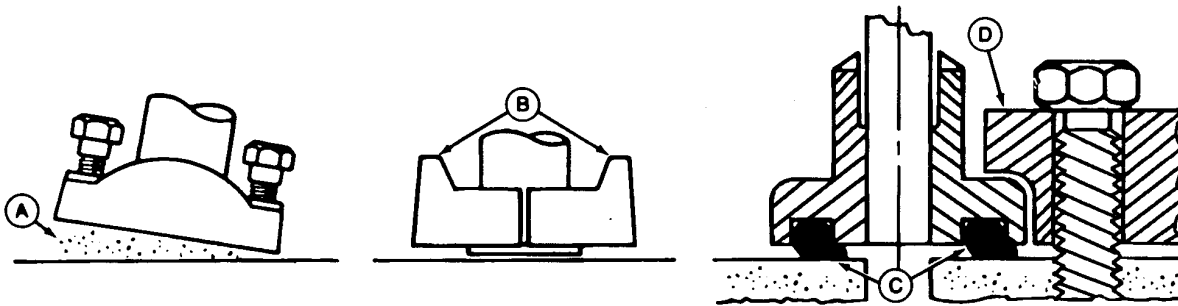

T6890BB—UN—01MAR90

A—Sealing Surface

B—Split Flange

C—Pinched O-Ring

D—Single Piece Flange

1. Clean sealing surfaces (A). Inspect. Scratches cause leaks. Roughness causes seal wear. Out-of-flat causes seal extrusion. If defects cannot be polished out, replace component.
2. Install the correct O-ring (and backup washer if required) into groove using petroleum jelly to hold it in place.
3. Split flange: Loosely assemble split flange (B) halves. Make sure split is centrally located and perpendicular to the port. Hand tighten cap screws to hold parts in place. Do not pinch O-ring (C).
4. Single piece flange (D): Place hydraulic line in center of flange and install four cap screws. Flange must be centrally located on port. Hand tighten cap screws to hold flange in place. Do not pinch O-ring.
5. After components are properly positioned and cap screws are hand tightened, tighten one cap screw, then tighten the diagonally opposite cap screw. Tighten two remaining cap screws. Tighten all cap screws as specified in the chart below.

DO NOT use air wrenches. DO NOT tighten one cap screw fully before tightening the others. DO NOT over tighten.

TORQUE CHART ^a		
Thread ^b	N·m	lb-ft
M6	12	9
M8	30	22
M10	57	42
M12	95	70
M14	157	116
M16	217	160
M18	334	246
M20	421	318

^aTolerance $\pm 10\%$. The torques given are enough for the given size connection with the recommended working pressure. Increasing cap screw torque beyond these amounts will result in flange and cap screw bending and connection failures.

^bMetric standard thread.

04T,90,K175 -19-29SEP99-1/1

This as a preview PDF file from best-manuals.com



Download full PDF manual at best-manuals.com