

5
4
0

5
4
3



Doosan purchased Bobcat Company from Ingersoll-Rand Company in 2007. Any reference to Ingersoll-Rand Company or use of trademarks, service marks, logos, or other proprietary identifying marks belonging to Ingersoll-Rand Company in this manual is historical or nominative in nature, and is not meant to suggest a current affiliation between Ingersoll-Rand Company and Bobcat Company or the products of either.

Service Manual

540 (S/N 501011999 & Below)
543 (S/N 501111999 & Below)

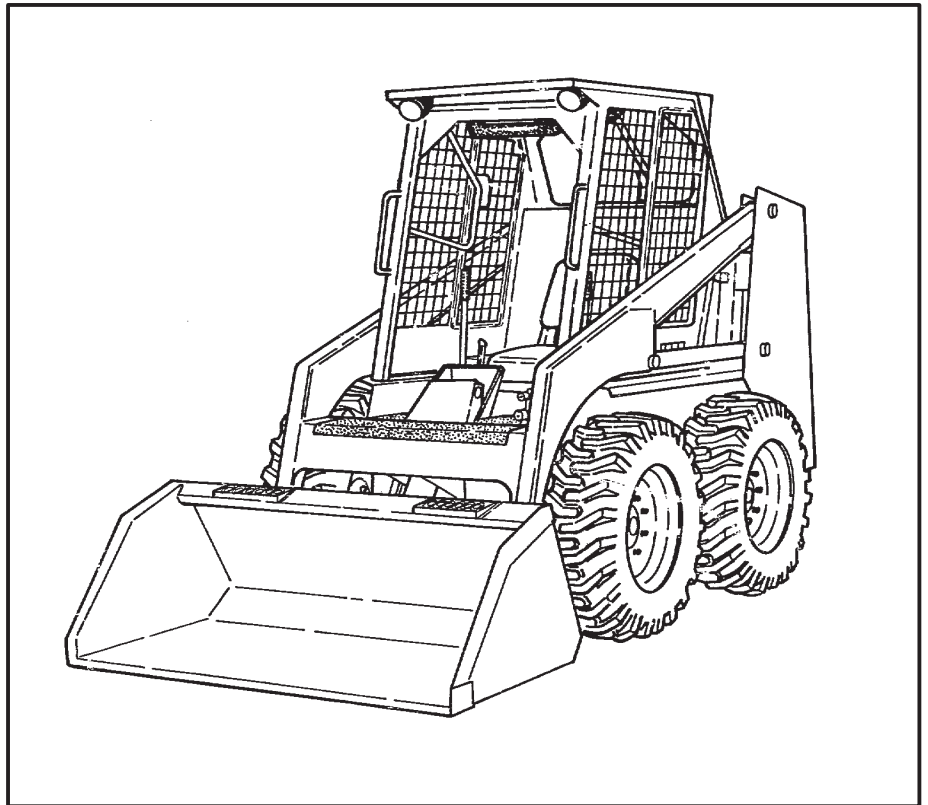

MELROE
INGERSOLL-RAND

6566181 (6-12)

Printed in U.S.A.



© Melroe Company 1981

MAINTENANCE SAFETY



WARNING

Instructions are necessary before operating or servicing machine. Read and understand the Operation & Maintenance Manual, Operator's Handbook and signs (decals) on machine. Follow warnings and instructions in the manuals when making repairs, adjustments or servicing. Check for correct function after adjustments, repairs or service. Untrained operators and failure to follow instructions can cause injury or death.

W-2003-0903



Safety Alert Symbol: This symbol with a warning statement, means: "Warning, be alert! Your safety is involved!" Carefully read the message that follows.

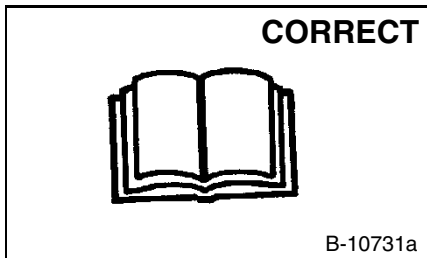

B-10731a

Never service the Bobcat Skid-Steer Loader without instructions.

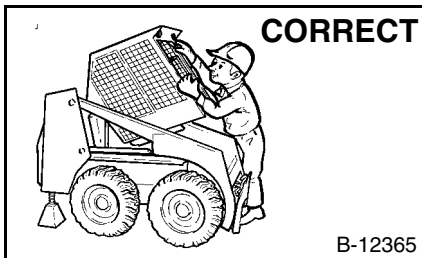

B-12365

Use the correct procedure to lift or lower operator cab.

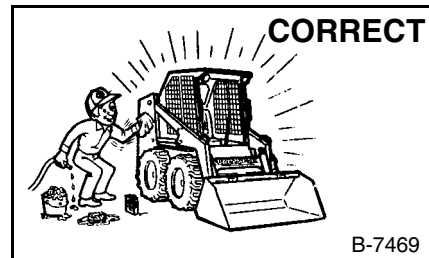

B-7469

Cleaning and maintenance are required daily.

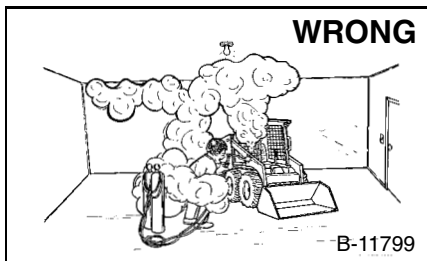

B-11799

- Have good ventilation when welding or grinding painted parts.
- Wear dust mask when grinding painted parts. Toxic dust and gas can be produced.
- Avoid exhaust fume leaks which can kill without warning. Exhaust system must be tightly sealed.

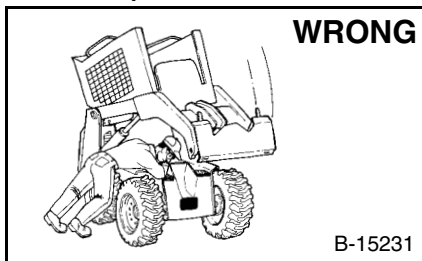

B-15231

Disconnecting or loosening any hydraulic tubeline, hose, fitting, component or a part failure can cause lift arms to drop. Do not go under lift arms when raised unless supported by an approved lift arm support device. Replace it if damaged.

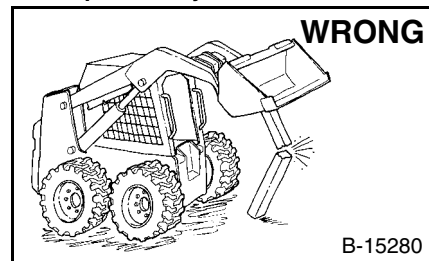

B-15280

- Never work on loader with lift arms up unless lift arms are held by an approved lift arm support device. Replace if damaged.
- Never modify equipment or add attachments not approved by Bobcat Company.

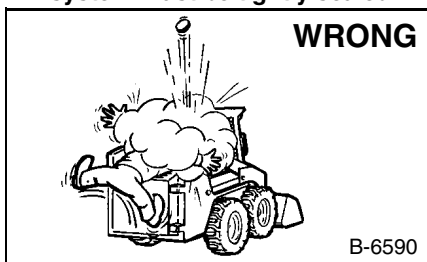

B-6590

- Stop, cool and clean engine of flammable materials before checking fluids.
- Never service or adjust loader with the engine running unless instructed to do so in the manual.
- Avoid contact with leaking hydraulic fluid or diesel fuel under pressure. It can penetrate the skin or eyes.
- Never fill fuel tank with engine running, while smoking or when near open flame.

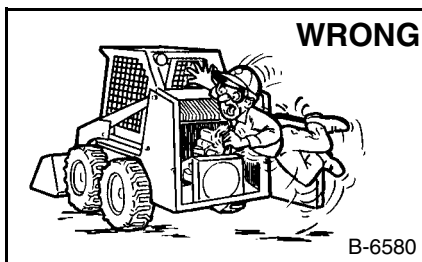

B-6580

- Keep body, jewelry and clothing away from moving parts, electrical contact, hot parts and exhaust.
- Wear eye protection to guard from battery acid, compressed springs, fluids under pressure and flying debris when engines are running or tools are used. Use eye protection approved for type of welding.
- Keep rear door closed except for service. Close and latch door before operating the loader.

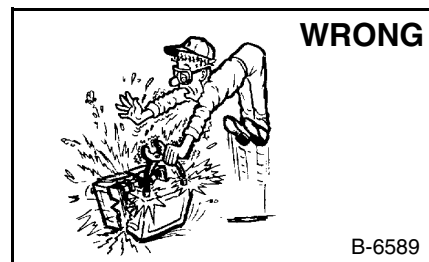

B-6589

- Lead-acid batteries produce flammable and explosive gases.
- Keep arcs, sparks, flames and lighted tobacco away from batteries.
- Batteries contain acid which burns eyes or skin on contact. Wear protective clothing. If acid contacts body, flush well with water. For eye contact flush well and get immediate medical attention.

Maintenance procedures which are given in the Operation & Maintenance Manual can be performed by the owner/operator without any specific technical training. Maintenance procedures which are **not** in the Operation & Maintenance Manual must be performed **ONLY BY QUALIFIED BOBCAT SERVICE PERSONNEL**. Always use genuine Bobcat replacement parts. The Service Safety Training Course is available from your Bobcat dealer.

MSW01-0805



Bobcat®

FOREWORD

This Service Manual gives the instructions for correct servicing, adjustment and overhauling of the Bobcat loader Hydraulic/Hydrostatic System, Drive System, Main Frame, Electrical System and Engine Service.

Make reference to the Operator's Manual for operating instructions (Starting, Daily Checks, Loader Operation, etc.).

A general inspection of the following items must be made when the Bobcat loader has had service or repair.

1. Check hydraulic/hydrostatic fluid level, engine oil level and fuel supply.
2. Inspect for any sign of fuel, oil or hydraulic fluid leaks.
3. Lubricate the loader.
4. Check the condition of the battery(ies) and the cables.
5. Inspect the air cleaner system for damage or leaks.
6. Check the warning lights to see if they light.
7. Check the tires for wear and pressure.
8. Check the Bob-Tach for wear and see if the wedges are damaged.
9. Check the safety items for condition (Operator Guard, Seat Belt, Seat Bar, Safety Signs (Decals), Safety Treads, etc.).
10. Make an inspection for loose or broken parts or connections.
11. Operate the loader, checking all functions.

Check the above items. If any are in need of repair or adjustment, contact the owner.

**PREVENTIVE
MAINTENANCE**

**HYDRAULIC
SYSTEM**

**HYDROSTATIC
SYSTEM**

**DRIVE
SYSTEM**

**MAIN
FRAME**

**ELECTRICAL
SYSTEM**

**ENGINE
SERVICE**

**TECHNICAL
DATA**

**ALPHABETICAL
INDEX**

CONTENTS

ALPHABETICAL INDEX	9
DRIVE SYSTEM	4
ELECTRICAL SYSTEM	6
ENGINE SERVICE	7
HYDRAULIC SYSTEM	2
HYDROSTATIC SYSTEM	3
MAIN FRAME	5
PREVENTIVE MAINTENANCE	1
TECHNICAL DATA	8



bobcat[®]

SAFETY INSTRUCTIONS

WARNING

Instructions are necessary before operating or servicing machine. Read Operation & Maintenance Manual, Handbook and signs (decals) on machine. Follow warnings and instructions in the manuals when making repairs, adjustments or servicing. Check for correct function after adjustments, repairs or service. Failure to follow instructions can cause injury or death.

W-2003-0797

The following publications provide information on the safe use and maintenance of the loader and attachments:

- The Delivery Report is used to assure that complete instructions have been given to the new owner and that the machine is in safe operating condition.
- The Operation & Maintenance Manual delivered with the loader gives operating information as well as routine maintenance and service procedures. It is a part of the loader and must stay with the machine when sold. Replacement Operation & Maintenance Manuals can be ordered from your Bobcat loader dealer.
- The loader has machine signs (decals) which instruct on the safe operation and care. The signs and their locations are shown in the Operation & Maintenance Manual. Replacement signs are available from your Bobcat loader dealer.
- The loader has a plastic Operator's Handbook fastened to the operator cab. Its brief instructions are convenient to the operator. The Handbook is available from your dealer in an English edition or one of many other languages. See your Bobcat dealer for more information on translated versions.
- The EMI Safety Manual (available in Spanish) delivered with the loader gives general safety information.
- The Service Manual and Parts Manual are available from your dealer for use by mechanics to do shop-type service and repair work.
- The Skid-Steer Loader Operator Training Course is available through your local dealer. This course is intended to provide rules and practices for correct operation of the Bobcat loader. The course is available in English and Spanish version.
- The Bobcat Skid-Steer Loader Safety Video is available from your Bobcat Dealer.

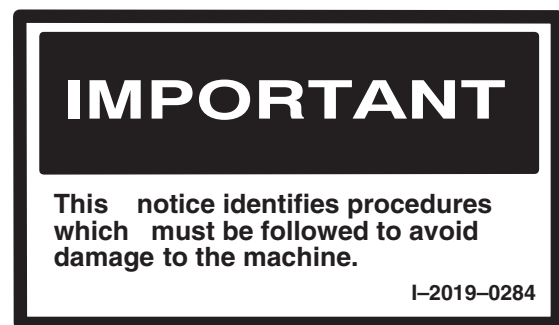

Safety Alert Symbol: This symbol with a warning statement, means: "Warning, be alert! Your safety is involved!" Carefully read the message that follows.

SAFETY INSTRUCTIONS (Cont'd)

- Wear tight fitting clothing. Always wear safety glasses when maintaining or servicing loader . Safety glasses, hearing protection or loader special applications kit are required for some work. See your dealer for Melroe Safety equipment.
- Know where fire extinguisher and first aid kit are located and how to use them.
- Do not use the Bobcat loader where exhaust, arcs, sparks or hot components can contact flammable material, explosive dust or gases.
- The engine compartment and engine cooling system must be inspected every day and cleaned if necessary to prevent fire hazard and overheating.
- Check all electrical wiring and connections for damage. Keep the battery terminals clean and tight. Repair or replace any damaged part.
- Check fuel and hydraulic tubes, hoses and fittings for damage and leakage. Never use open flame or bare skin to check for leaks. Tighten or replace any parts that show leakage. Always clean fluid spills. Do not use gasoline or diesel fuel for cleaning parts. Use commercial nonflammable solvents.
- Follow any environmental safety regulations when disposing of used fluids such as engine oil, grease or anti-freeze.
- Do not use ether or starting fluids on engines which have glow plugs. These starting aids can cause explosion and injure you or bystanders.
- Always clean the loader and disconnect the battery before doing any welding. Cover rubber hoses, battery and all other flammable parts. Keep a fire extinguisher near the loader when welding. Have good ventilation when grinding or welding painted parts. Wear dust mask when grinding painted parts. Toxic dust or gas can be produced.
- Stop the engine and let it cool before adding fuel. No smoking!
- Use the procedure in the Operation & Maintenance or Service Manuals for connecting the battery.

A fire extinguisher is available from your local dealer. The fire extinguisher can be installed in the location shown [A].



PREVENTIVE MAINTENANCE

PREVENTIVE MAINTENANCE

	Paragraph Number	Page Number
ELECTRICAL SYSTEM	1-4	1-8
ENGINE SERVICE	1-3	1-4
FINAL DRIVE	1-6	1-13
HYDRAULIC/HYDROSTATIC SYSTEM .	1-5	1-11
INTRODUCTION	1-1	1-1
OPERATOR GUARD	1-8	1-14
LIFT ARM STOP	1-11	1-16
LUBRICATION OF THE LOADER	1-9	1-14
SERVICE SCHEDULE	1-2	1-3
SPARK ARRESTOR MUFFLER	1-7	1-13
STOPPING THE BOBCAT LOADER	1-12	1-16
TRANSPORTING THE BOBCAT LOADER	1-10	1-15



WARNING

DO NOT service the Bobcat loader without instructions or taking the necessary safety precautions. Before working on the loader, see the warnings and instructions at the beginning of this Service Manual. After making the repair or adjustment, always check the function of the loader. Failure to obey warnings may cause injury or death.



bobcat[®]

1 PREVENTIVE MAINTENANCE

1-1 INTRODUCTION

The Preventive Maintenance Section of this Service Manual gives general maintenance procedures for the Bobcat loader. The other sections of the Service Manual will give the detailed description needed for disassembly and assembly and when replacement parts are needed.

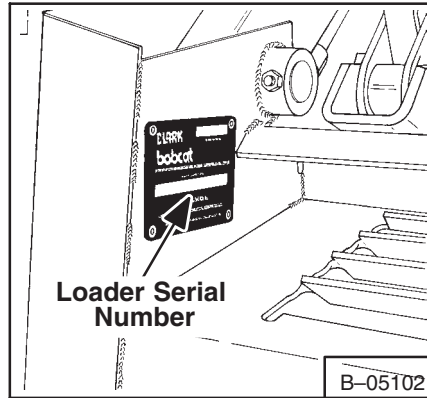

Fig. 1-1 Loader Serial Number

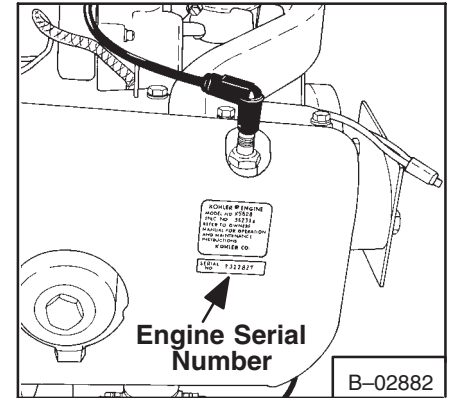

Fig. 1-2 Engine Serial Number (540)

1-1.1 Serial Number Identification

It is important to make correct reference to the Serial Number of the Bobcat loader and/or engine when making repairs or ordering parts. It is possible that the present loaders do not use all the same parts as the earlier loaders. It is possible that different procedures are used for service repair.

1-1.2 Loader Serial Number

The Bobcat loader serial number plate location is on the inside of the left upright, above the grill (Fig. 1-1).

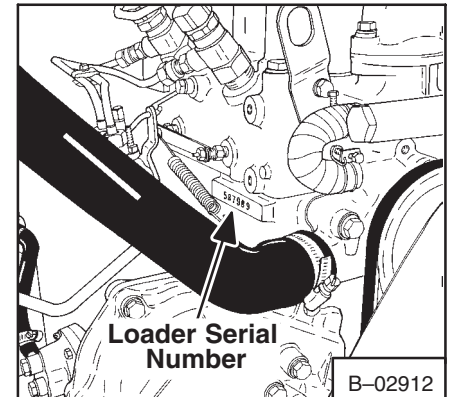
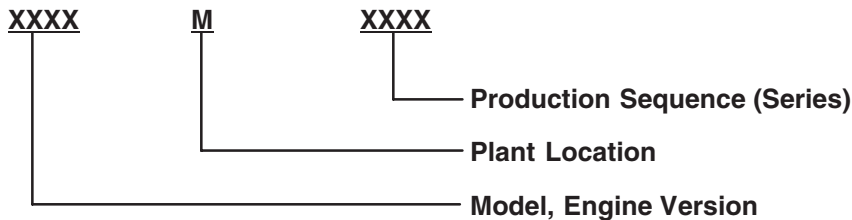

Fig. 1-3 Engine Serial Number (543)

Explanation of the Serial Number:



1-1.3 Engine Serial Number

The engine serial number for the 540 Bobcat loader is located on the blower housing at the right side of the engine (Fig. 1-2).

The engine serial number for the 543 Bobcat loader is located at the left side of the engine above the fuel injection pump (Fig. 1-3).

1-1.4 Pre-Delivery Inspection (Fig. 1-4).

The Pre-Delivery Inspection must be completed when the new Bobcat gets to the dealer and before it is delivered to the customer.

The purpose of the Pre-Delivery Inspection is:

1. To see if the Bobcat loader is in correct operating condition at the time of the delivery.

Fig. 1-4 Pre-Delivery Inspection Form

- To let the factory know when something is wrong with the Bobcat loader so that the problem can be corrected and prevented in the future.

All items on the inspection form must be completed according to the specifications in this manual.

One copy of the completed form is to be mailed to:

**CLARK EQUIPMENT
MELROE DIVISION
QUALITY CONTROL DEPT.
GWINNER, ND 58040**

The other copy is for the dealer records.

1-1.5 Thirty Hour Inspection (Fig. 1-5)

The 30 Hour Inspection must be completed after the first 30 hours of loader operation.

The purpose of the 30 Hour Inspection is:

- For adjustment and inspection after the first work period.
- To correct wrong maintenance and operation methods.
- For demonstrating correct service procedure to the customer.

All the items on the 30 Hour Inspection must be completed. The form must be done by the serviceman (mechanic), according to specifications in this manual.

When the 30 Hour Inspection has been completed, the form must be signed by (1) the serviceman (mechanic) that completed the inspection; (2) the Dealer; and (3) the owner/operator.

One copy of the completed form is to be mailed to:

**CLARK EQUIPMENT
MELROE DIVISION
SERVICE DEPT.
GWINNER, ND 58040**

One copy is for the owner/operator and one copy for the Dealer's records.

The form is titled "30 HOUR OPERATIONAL & SERVICE INSPECTION" and is for Bobcat loaders. It includes the following sections:

- IMPORTANT:** This inspection is to be performed each month. Check, repair, adjust, lubricate, adjust, or replace as necessary. Mark items which need repair, replace, or adjust. Mechanical failures require repair with the appropriate repair manual for Specifications & Details.
- SERVICE INSPECTION:**
 - Inspect and adjust air and fuel with cover cap. Inspect and adjust. Adjust or replace as necessary.
 - Inspect air filter system and clean or replace as necessary.
 - Inspect engine cooling system. Clean or repair as necessary.
 - Change engine oil and filter.
 - Lubricate and adjust track pins or bolts to correct loader and skid steer systems. Tighten and adjust suspension.
 - Adjust spring assemblies. Lubricate suspension. Check for proper operation. Lubricate suspension.
 - Check tight and true wheels. Lubricate suspension.
 - Check hydraulic system. Lubricate suspension. Check for proper operation.
 - Change hydraulic oil filter.
 - Inspect air pressure for proper operation. Repair or adjust as necessary.
 - Inspect skid steer tires. Inspect condition. Lubricate suspension and adjust.
 - Inspect all electrical systems. Tighten and adjust electrical system. Check wiring system and suspension.
 - Check tires for proper inflation and air leakage.
 - Check skid steer or skid steer system.
 - Check skid steer for proper operation.
- OPERATIONAL INSPECTION:**
 - Check skid steer for proper operation.
 - Check skid steer for proper operation.
 - Check skid steer for proper operation.
 - Check skid steer for proper operation.

The form also includes signature lines for the Dealer, Owner/Operator, and Serviceman, and a section for "CLARK EQUIPMENT" contact information.

Fig. 1-5 30 Hour Inspection

1-2 SERVICE SCHEDULE

Maintenance work must be done at regular intervals. Failure to do so will result in damage to the Bobcat loader or the engine. The service schedule is a guide for correct maintenance of the Bobcat loader DO NOT change this service schedule unless the frequency of service is increased when the Bobcat loader is operated in very hot, cold, dusty or corrosive conditions.

WARNING

DO NOT work on the loader with the lift arms in a raised position without support. Use lift arm stops or other methods.

MODEL		SERVICE SCHEDULE		HOURS					
540	543	ITEM	SERVICE REQUIRED	8-10	50	100	250	500	1000
		Engine Air Cleaner	Check the condition indicator. Make inspection of the air cleaner system. Replace the element when the ring shows in the indicator window.						
		Engine Oil	Check level and add oil as needed.						
		Engine Cooling System	Check and clean as needed (Including oil cooler grill)						
		Engine Coolant System	Check the coolant level and add as needed. Remove any debris from the radiator grill area.						
		Tires	Check for damage and check the tire pressure.						
		Operator Guard, Seat Belt & Seat Bar	Check the operator guard fastening bolts to make sure they are tight. Check the condition of the seat belt. Check the seat bar for correct operation.						
		Safety Signs (Decals)	Check for damaged decals. Replace any decals that are not there.						
		Pivot Points	Add lubricant to all fittings.						
		Hydraulic/Hydrostatic Fluid	Check the fluid level and add the recommended fluid as needed (See Section 8 for correct fluid).						
		Engine Oil and Filter	Change, fill with new clean oil according to oil specification chart & install new filter.						
		Battery	Check the battery cables & the battery water level.						
		Control Pedals and Steering Levers	Check both for correct operation. Make repairs & adjustments as needed.						
		Bob-Tach	Check locking levers and wedges for condition and operation.						
		Brakes	Check operation. Make adjustment as needed.						
		Chaincase Fluid	Check level. Add fluid as needed.						
		Hydraulic/Hydrostatic Filter	Replace the filter element.						
		Spark Arrestor Muffler	Remove the plug and clean the spark chamber.						
		Engine Ignition System	Check the points & timing. Replace the spark plugs.						
		Engine Cylinder Head Bolts	Tighten to correct torque after first 100 hours of loader operation. Adjust valve tappets.						
		Engine Air Housing	Remove and clean housing and cooling fins.						
		Engine Air Cleaner System	Check system for leaks. Replace element as needed.						
		Injection Pump Oil	Check oil level at check plug.						
		Engine Fuel Filter	Replace element or clean as needed.						
		Injection Pump Oil	Replace the oil in the injection pump reservoir.						
		Seat Bar	Lubricate the detent mechanism.						
		Steering Levers	Add grease to the pivot bearings.						
		Chaincase	Replace the fluid.						
		Hydraulic/Hydrostatic System	Replace the fluid. Clean the inlet screen and vent.						

1-3 ENGINE SERVICE (General)

! WARNING

Stop, cool and clean the engine of flammable material. Never service or adjust machine with the engine running unless instructed to do so.

Open the rear door to service the engine. Pull the door latch up (Fig. 1-6) and turn to the left to release the door latch (Fig. 1-7). The door can then be fully opened to get to the engine. Push down on the door stop to hold the door open (Fig. 1-8), if so equipped. See Section 5 for the Door Latch Adjustment.

! WARNING

Keep the rear door closed except for service. Make sure you close the door and fasten the latch tightly before operating the Bobcat loader.

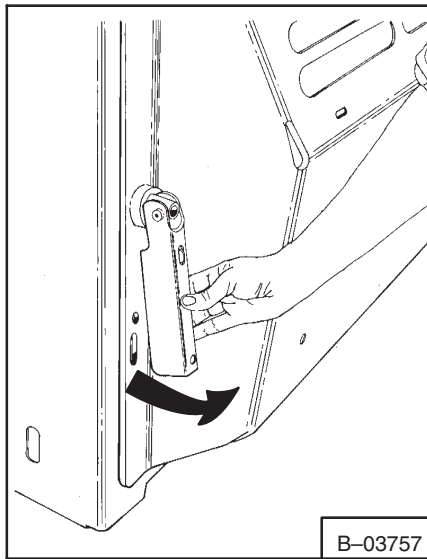

Fig. 1-6 Opening Door Latch

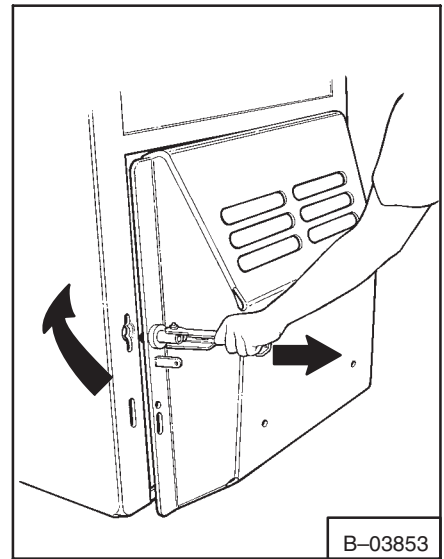

Fig. 1-7 Opening Rear Door

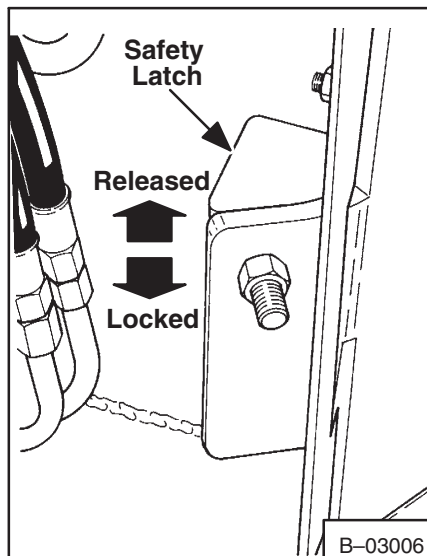

Fig. 1-8 Safety Latch

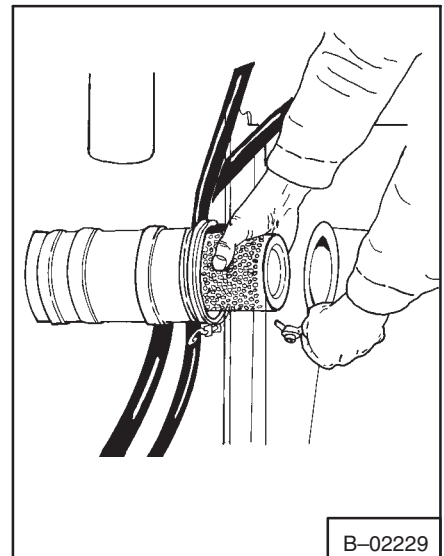

Fig. 1-9 Removing Air Cleaner Element

1-3.1 Air Cleaner Service

It is important to service the air cleaner at regular intervals for good engine performance and long service life.

Service the air cleaner as follows (Fig. 1-9):

1. Remove the dust cap and clean every day.
2. Make replacement of the element only when it becomes necessary.

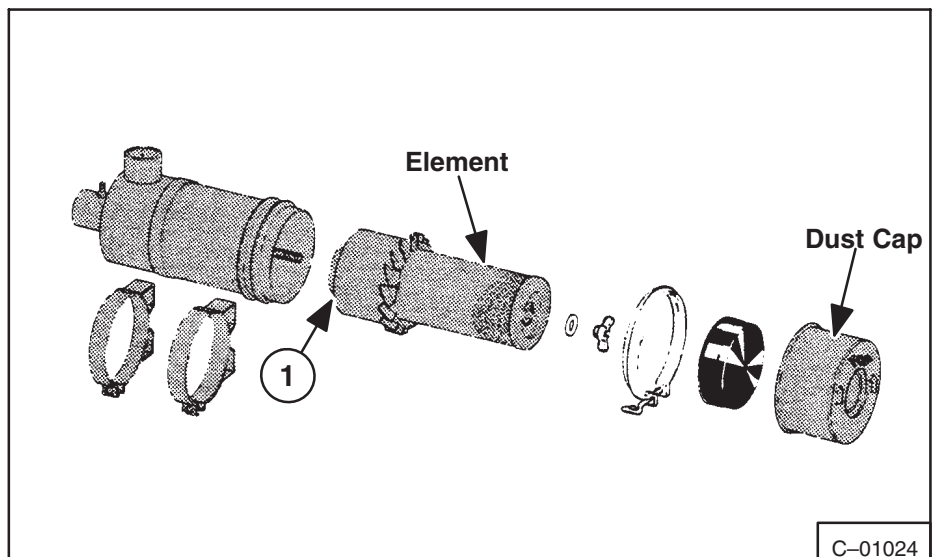

Fig. 1-10 Air Cleaner Assembly

3. Clean the inside of the filter housing so that the element has a smooth surface to contact at the seal (Fig. 1-10, Item 1). Check the filter housing for holes for corrosion, especially if the Bobcat loader is used in fertilizer application.
4. Install the filter element and tighten the wing nut.
5. Install the dust cap and tighten the clamp.
6. Check the hoses and clamps are tight.

1-3.2 Fuel System

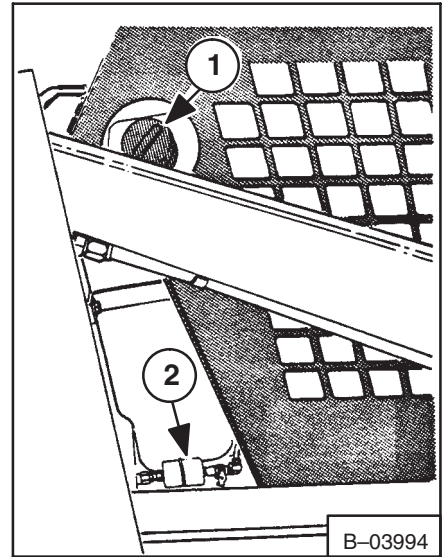

Fig. 1-11 Fuel Fill Location (540)



WARNING

Never add fuel to the Bobcat loader when the engine is running or is hot. NO SMOKING!

Use 85 octane regular gasoline in the engine of the 540 Bobcat loader.

Use number 2 diesel fuel in the engine of the 543 Bobcat loader. During very cold temperature conditions, number 1 fuel is recommended.

To add fuel to the tank (Fig. 1-11 & 1-12), use the following procedure:

1. Use a clean, approved safety container to add the fuel.
2. The key switch must be in the "OFF" position and the engine cool.
3. Add fuel only in an area that has free movement of air and no open flames or sparks. NO SMOKING (Fig. 1-13).
4. Use only clean fuel of the correct specifications.
5. Tighten the cap (Fig. 1-11, Item 1 & 1-12, Item 1) on the fuel tank.

540 Bobcat Loader: There is a fuel filter (Fig. 1-11, Item 2) in the fuel line by the fuel shut-off valve. The fuel filter must be replaced every 250 hours of loader operation. See Section 7 for the correct replacement procedure.

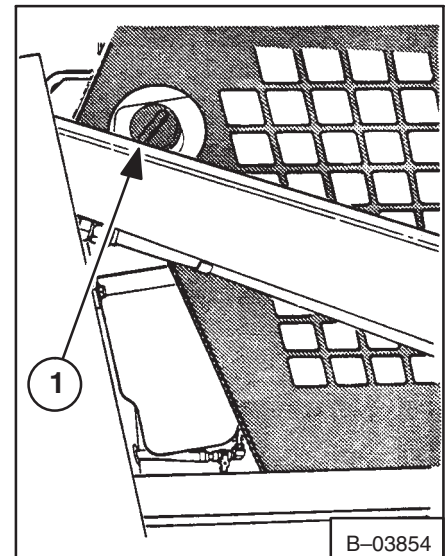

Fig. 1-12 Fuel Fill Locations (543)

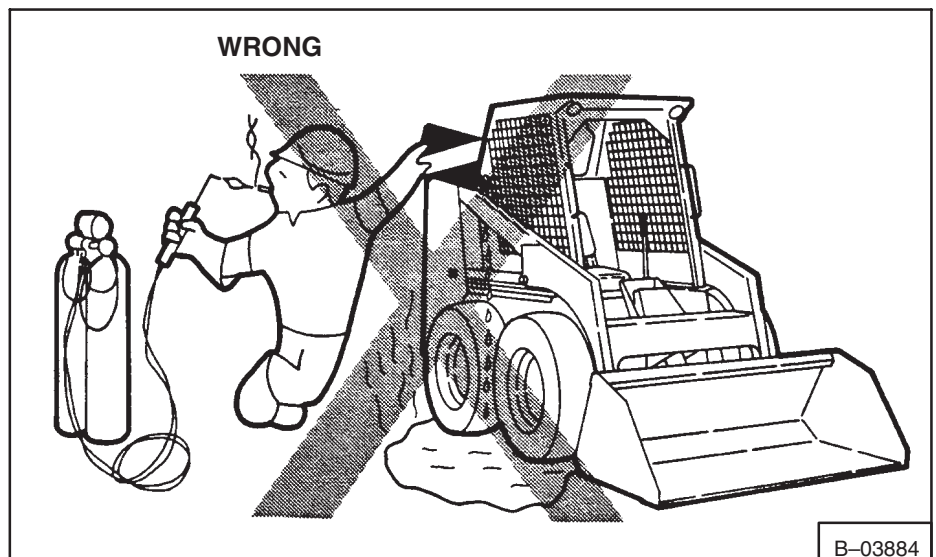

Fig. 1-13 Fuel Fill Warning

543 Bobcat Loader: There is a fuel filter located on the left side of the engine. The fuel filter must be replaced every 250 hours of loader operation. See Section 7 for the correct replacement procedure.

1-3.3 Engine Lubrication System

Check the oil level each day.

To check the oil level, stop the engine, open the rear door and remove the dipstick (Fig. 1-14 & 1-15).

Keep the oil level between the marks on the dipstick (Fig. 1-16). DO NOT fill above the top mark. Use a good quality motor oil that meets API Service Classification (See Chart Below).

1-3.4 Replacement of the Engine Oil and Filter

Replace the engine oil and filter every 50 hours of loader operation.

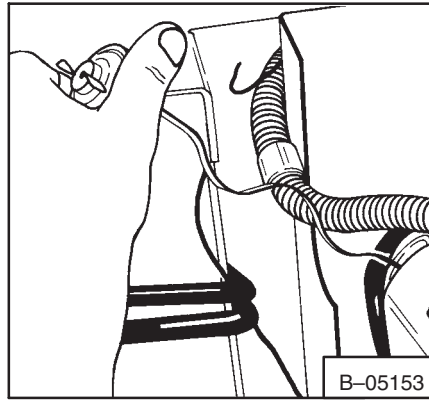

Fig. 1-14 Checking Engine Oil (540)

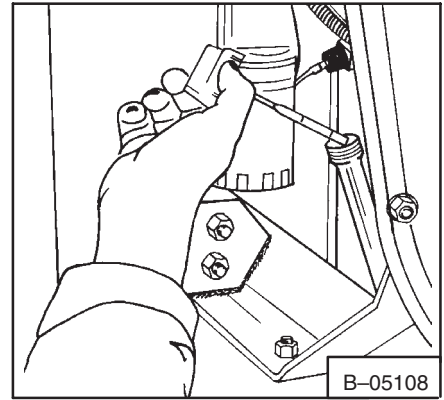
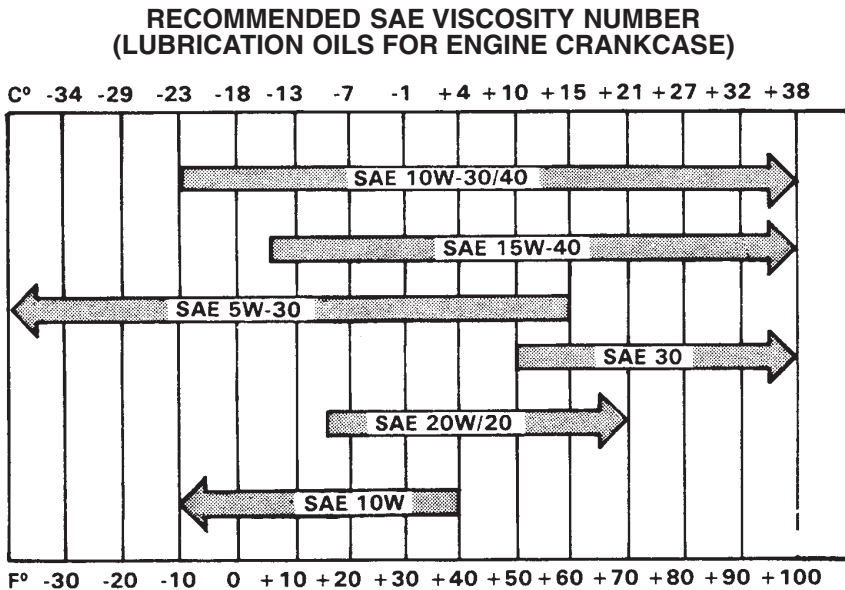

Fig. 1-15 Checking Engine Oil (543)



Fig. 1-16 Engine Dipstick



**TEMPERATURE RANGE ANTICIPATED BEFORE NEXT OIL CHANGE
(GASOLINE: USE API CLASSIFICATION SF)
(DIESEL: USE API CLASSIFICATION CD)**

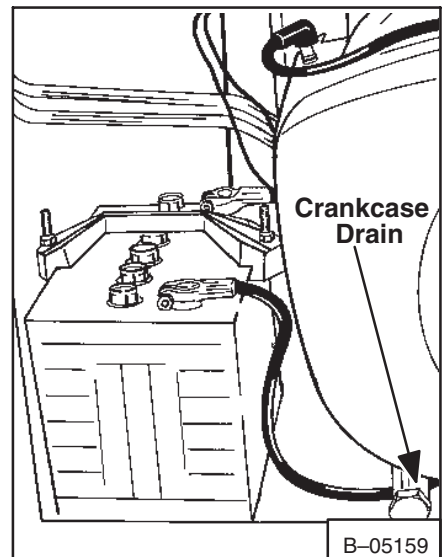

Fig. 1-17 Oil Drain (540)

To replace the engine oil and filter, use the following procedure:

1. Run the engine until it is at operating temperature. Stop the engine. Open the rear door.
2. Remove the drain plug (540-Fig. 1-17) (543-Fig. 1-19, Item 1).

3. Remove the oil filter (540—Fig. 1-18) (543—Fig. 1-19, Item 2).
4. Clean the filter housing surface.
5. Install the drain plug. Remove the oil fill cap (540—Fig. 1-14) (543—Fig. 1-19, Item 3). Add the correct amount of oil to the engine (See the Oil Chart for the correct oil).
6. Start the engine and let it run for several minutes. Stop the engine. Check the oil level. Add oil if the level is not at the top mark on the dipstick (Fig. 1-16).

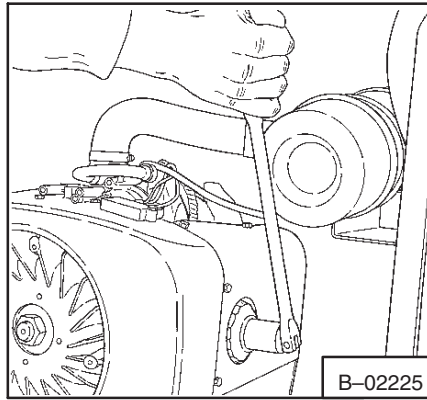

Fig. 1-18 Oil Filter (540)

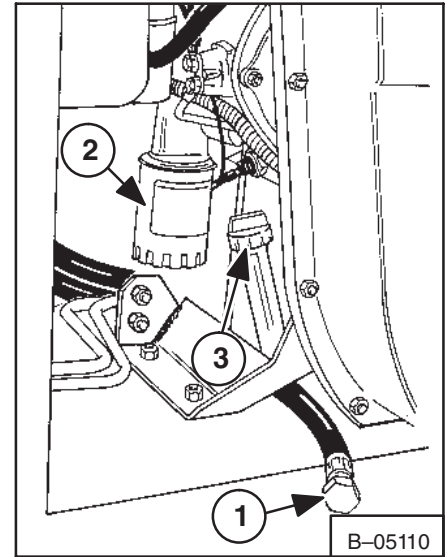

Fig. 1-19 Engine Service (543)

1-3.5 Engine Cooling System

540 Bobcat Loader: The oil cooler grill and engine cylinder cooling fins must be kept clean and free of debris or overheating of the engine will result.

! WARNING

Use safety goggles when using air pressure to clean the grill area. DO NOT use cold water on a hot engine.

Use air pressure or water to clean the oil cooler grill (Fig. 1-20).

Remove the shrouding on the engine to clean the cooling fins. Make sure to wear safety goggles when using air pressure or water spray for cleaning the fins.

Use a brush and scraper tool to remove the hard deposits on the cooling fins (Fig. 1-21). The oil cooler can be removed for better cleaning.

Make sure to replace all the covers and shrouding after cleaning the engine.

IMPORTANT

Never operate the engine with any of the covers or shrouding removed.

543 Bobcat Loader: The radiator grill area must be kept clean and free of debris or overheating of the engine will result.

Keep the blower fan clean and free from debris (Fig. 1-22, Item 1).

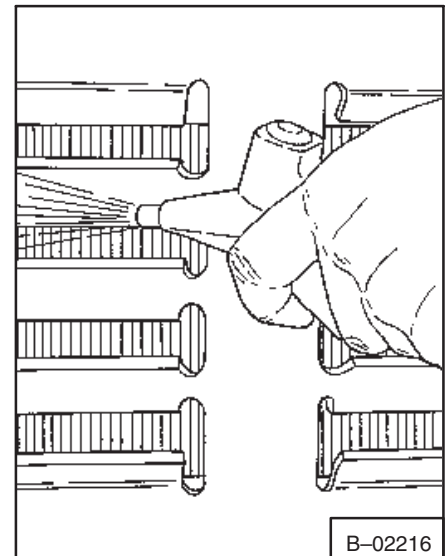

Fig. 1-20 Cleaning Grill (540)

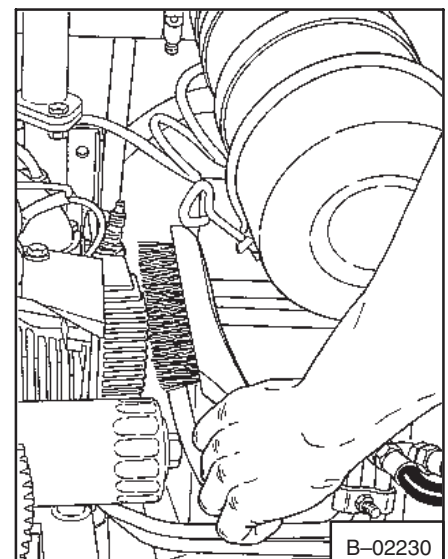

Fig. 1-21 Cleaning Cooling Fins (540)

Check the coolant level every day at the coolant recovery tank (Fig. 1-22, Item 2). Correct level of the recovery tank is 1/3 full when the engine is cold and 2/3 full when the engine is warm.

Add coolant at the recovery tank only.

NOTE: Protect the cooling system from freezing temperatures by adding 50/50 ethylene glycol and water (Pre-Mixed) to the cooling system.

The cooling system must be drained and flushed clean at one year intervals. Fill with clean coolant that contains rust inhibitor.

1-4 ELECTRICAL SYSTEM

1-4.1 Electrical System Service

1. Check the battery cables and make sure they are clean and tight. Check the water level of the battery. Remove any acid or corrosion from the battery and cables with a sodium bicarbonate and water solution (Fig. 1-23). Cover the battery terminals and cables with grease.
2. Check the tension of the alternator belt (See Section 6 for the correct procedure).
3. Check all wires for being broken or open wires.

NOTE: The warning lights (on the dash panel) will come ON when the key switch is turned ON. When the engine is started, the warning lights must go OFF. If they do not, stop the engine and find the problem.

1-4.2 Using an Extra Battery (Booster Starting)

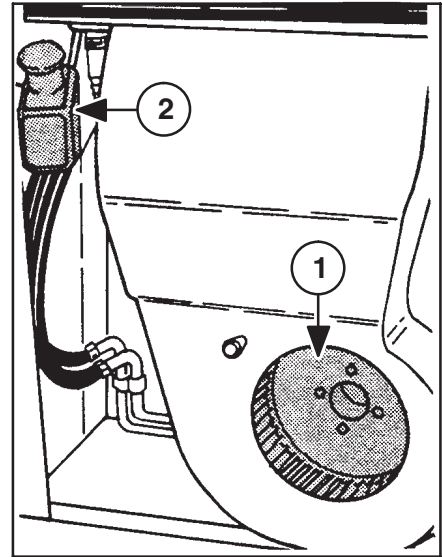

Fig. 1-22 Coolant Recovery Tank (543)

**WARNING**

Keep arcs, sparks, flames and lighted tobacco away from batteries. When jumping from booster battery make final connection (negative) at engine frame.

Do not jump start or charge a frozen or damaged battery. Warm battery to 60°F. (16°C) before connecting to a charger. Unplug charger before connecting or disconnecting cables to battery. Never lean over battery while boosting, testing or charging.

Battery gas can explode and cause serious injury.

W-2066-1296

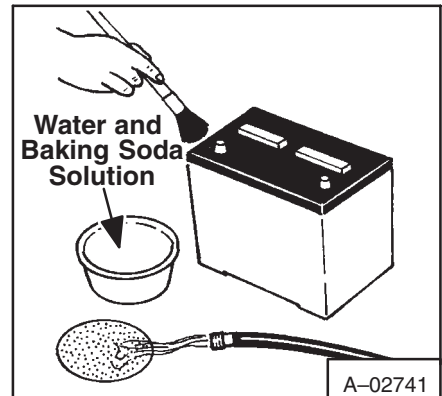

Fig. 1-23 Cleaning the Battery

If it is necessary to use an extra battery to start the engine, BE CAREFUL! This is a two-person operation. There must be one person in the operator's seat and one person to connect and disconnect the battery cables.



WARNING

Batteries contain acid which burns eyes and skin on contact. Wear goggles, protective clothing and rubber gloves to keep acid off body.

In case of acid contact, wash immediately with water. In case of eye contact get prompt medical attention and wash eye with clean, cool water for at least 15 minutes.

If electrolyte is taken internally drink large quantities of water or milk! DO NOT induce vomiting. Get prompt medical attention.

W-2065-1296

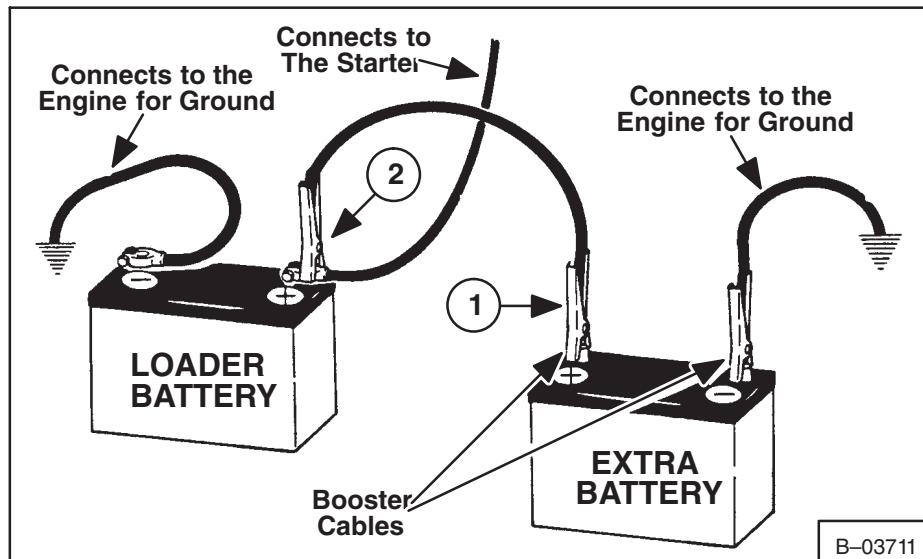

Fig. 1-24 Connecting the Extra Battery

If it is necessary to use an extra battery to start the engine, BE CAREFUL! This is a two-person operation. There must be one person in the operator's seat and one person to connect and disconnect the battery cables.

1. The ignition must be in the off position.
2. The battery to be used must be of the same voltage.
3. Battery terminals have identification marks. The positive terminal is marked (+) and the negative terminal is marked (-).
4. The negative terminal (-) of the battery must be connected to the engine.



WARNING

Keep arcs, sparks, flames and lighted tobacco away from batteries. When jumping from booster battery make final connection (negative) at engine frame.

Do not jump start or charge a frozen or damaged battery. Warm battery to 60°F. (16°C) before connecting to a charger. Unplug charger before connecting or disconnecting cables to battery. Never lean over battery while boosting, testing or charging.

Battery gas can explode and cause serious injury.

W-2066-1296

5. Connect the end of the first cable to the positive terminal (+) of the booster (Fig. 1-24, Item 1). Connect the other end of the same cable to the positive terminal (+) of the loader battery (Fig. 1-24, Item 2).
6. Connect the end of the second cable to the negative terminal (-) of the booster battery (Fig. 1-24, Item 3). Connect the other end of the second cable to the engine (Fig. 1-24, Item 4). DO NOT connect the cable directly to the negative terminal (-) of the loader battery. Connecting the cable directly to the battery can cause a spark and destroy the battery and cause personal injury.
7. Keep the cables away from the fans and belts.

NOTE: The operator must be in the operator's seat and have the seat belt fastened.

8. Start the engine.
9. After the engine has started, remove the cable connected to the engine (Fig. 1-24, Item 4).
10. Then remove the cable from the loader battery post positive terminal (Fig. 1-24, Item 2).

IMPORTANT

Damage to the alternator will occur if:

- The engine is operated with battery cables disconnected.
- The cables are connected when using a fast charger or when welding on the Bobcat loader (Remove both cables from the battery).
- The extra battery cables are connected wrong.

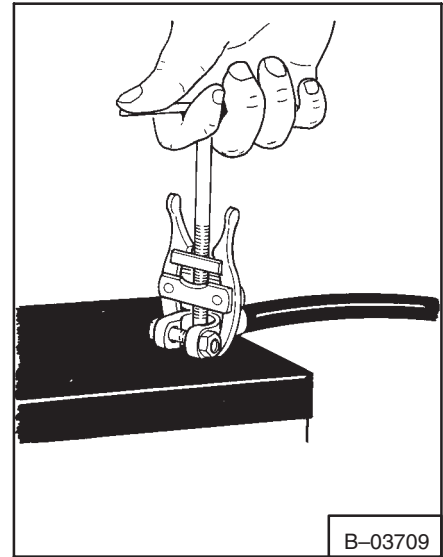

B-03709

Fig. 1-25 Removing Cable

1-4.3 Installing New Battery

NOTE: See Section 6 Paragraph 6-3.1 and 6-3.3 for more information on removing and replacing batteries.

1. Remove the negative battery cable from the battery first, using a cable puller (Fig.1-25). Remember the position of the battery cables so you can connect the cables correctly when installing the battery.
2. Remove the battery holddown clamp (Fig. 1-26 or 1-27). Remove the battery from the battery compartment.
3. Clean the terminal posts (Fig. 1-28) of the new battery and the ends on the battery cables.
4. Install the new battery in the battery compartment.
5. Install the holddown clamp (Fig. 1-26 or 1-27).
6. Install the positive battery cable first and tighten. Connect the negative cable last to prevent sparks.

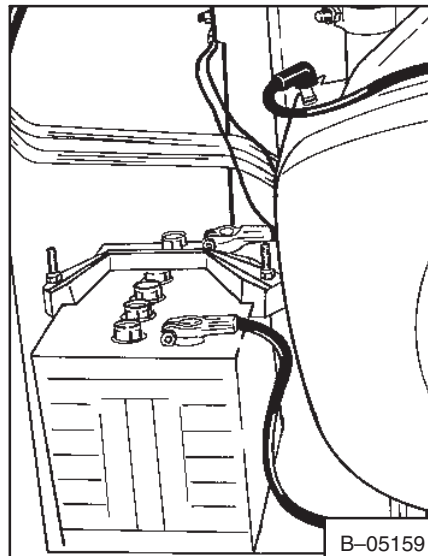

B-05159

Fig. 1-26 Location of the Battery (540)

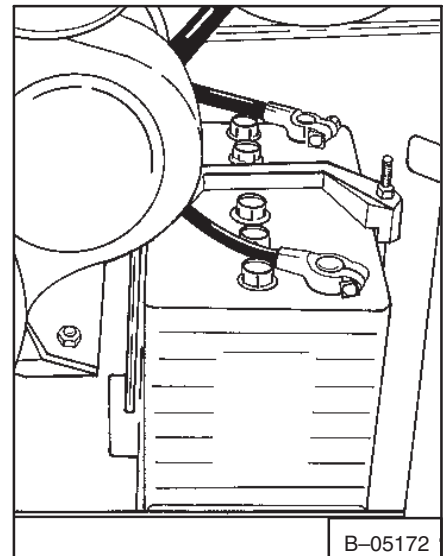

B-05172

Fig. 1-27 Location of the Battery (543)

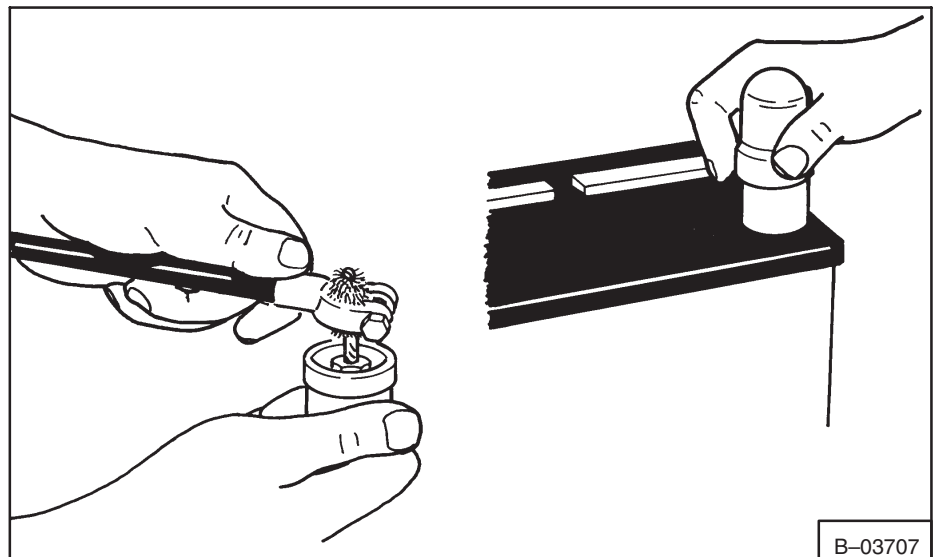

B-03707

Fig. 1-28 Cleaning Battery Terminals

1-5 HYDRAULIC/HYDROSTATIC FLUID

NOTE: For more information on the Hydraulic System see Section 2 and for more information on the Hydrostatic System see Section 3.

 WARNING	<p>Diesel fuel or hydraulic fluid under pressure can penetrate skin eyes, causing serious injury or death. Fluid leaks under pressure may not be visible. Use a piece of cardboard or wood to find leaks. Do not use your bare hand. Wear safety goggles. If fluid enters skin or eyes, get immediate medical attention from a physician familiar with this injury.</p> <p style="text-align: right;">W-2072-0496</p>
--	---

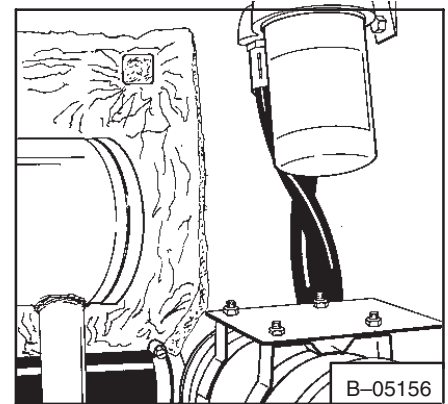

Fig. 1-29 Filter Location (540)

1-5.1 Replacing the Hydraulic/Hydrostatic Filter

The tools listed will be needed to do the following procedure:

MEL-1183 Filter Wrench

Replace the hydraulic/hydrostatic filter every 100 hours of loader operation or as often as necessary.

To replace the hydraulic/hydrostatic filter, use the following procedure:

1. Stop the engine. Open the rear door.
2. Clean the area around the filter housing.
3. Remove the filter element (Fig. 1-29 or 1-30) with a filter wrench.
4. Clean the surface of the filter housing head where the filter element seal contacts the filter housing.
5. Lubricate the rubber gasket with fluid.
6. Install the filter element and hand tighten only.
7. Operate the loader and check for leaks at the filter.

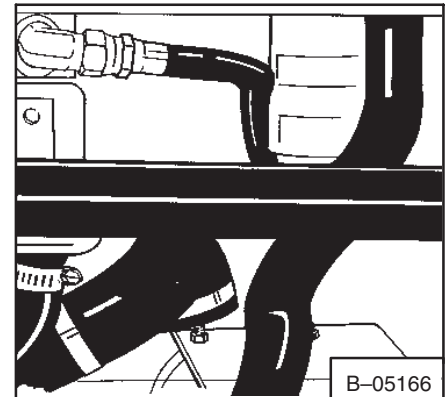

Fig. 1-30 Filter Location (543)

1-5.2 Checking and Adding Hydraulic/Hydrostatic Fluid

1. Put the loader on a level surface, lower the lift arms and tilt the Bob-T ach fully back. Stop the engine.
2. Open the bottom check valve on the side of the reservoir (Fig. 1-31, Item 1). The fluid level is good if the fluid level is between the top and bottom check valves. If no fluid flows, close the valve and proceed with step 3.
3. Open the top check valve (Fig. 1-31, Item 2). Remove the fill cap (Fig. 1-31, Item 3) from the reservoir. Add fluid to the reservoir until it flows from the top check valve. Close the valve and replace the fill cap (See Section 8 for the correct fluid specifications).

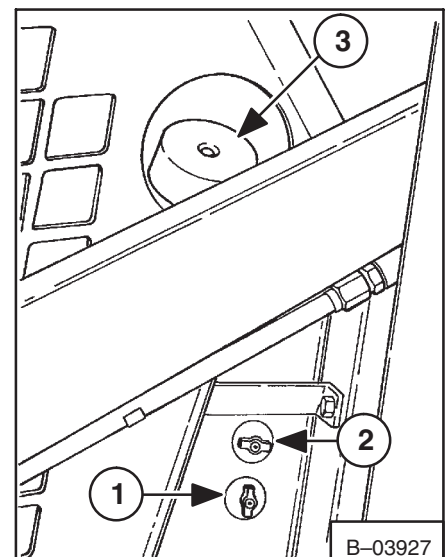

Fig. 1-31 Checking/Adding Fluid

1-5.3 Removing the Hydraulic/Hydrostatic Fluid

The hydraulic/hydrostatic fluid must be removed from the reservoir every 1000 hours of loader operation.

Replace the hydraulic/hydrostatic fluid more often if it becomes dirty or after any major repairs.

1. To Remove the fluid from the reservoir, use the following procedure:

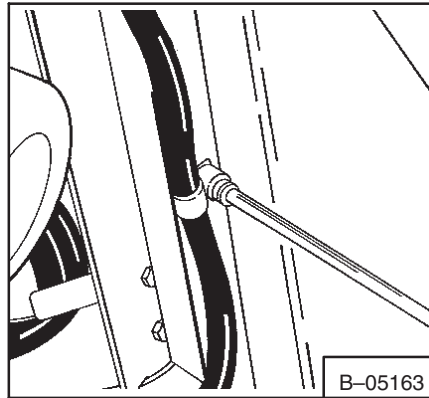

Fig. 1-32 Hose Clamp

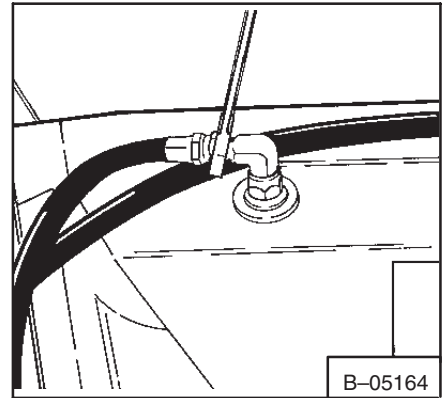

Fig. 1-33 Hose Fitting

540 Bobcat Loader:

- (a) Open the rear door and remove the hose clamp (Fig. 1-32) from the rear door.

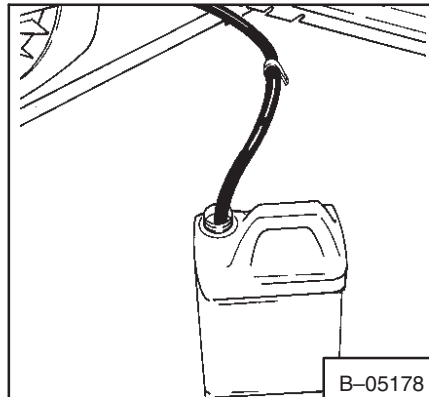

Fig. 1-34 Removing Fluid

- (b) Remove the hose at the oil cooler fitting (Fig. 1-33).

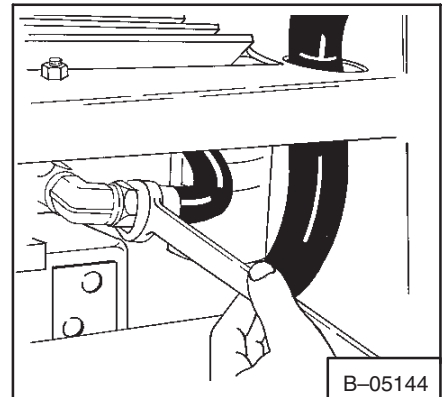

Fig. 1-35 Hose Fitting

- (c) Put the hose in a container and drain the hydraulic/hydrostatic reservoir (Fig. 1-34).

543 Bobcat Loader

- (a) Open the rear door and remove the hose at the oil cooler fitting (Fig. 1-35).

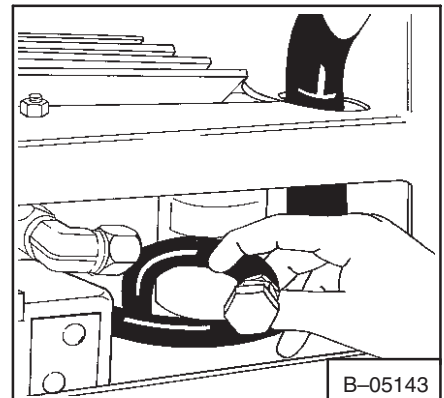

Fig. 1-36 Hose Plug

- (b) Put plugs in the hose and the oil cooler (Fig. 1-36).

- (c) Pull the hose between the hydraulic/hydrostatic filter and the main frame and down and out of the rear of the loader.

- (d) Remove the plug, put the hose in a container (Fig. 1-37) and drain the hydraulic/hydrostatic reservoir.

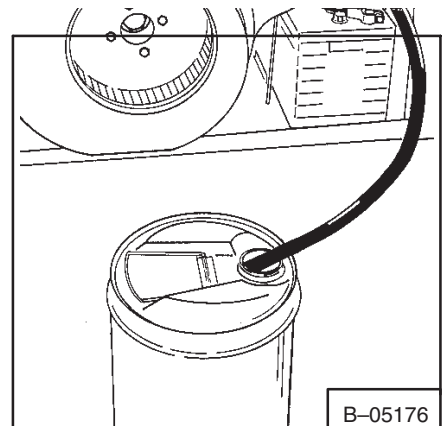

Fig. 1-37 Removing Fluid

2. After all the fluid is removed from the reservoir, connect the hose.

3. Remove the snap ring and remove the 100 mesh screen from the reservoir fill pipe (Fig. 1-38). Wash the screen in clean solvent and install it in the fill pipe.
4. Fill a new filter element (See Paragraph 1-5.1).
5. Add hydraulic/hydrostatic fluid to the reservoir (See Paragraph 1-5.2).
6. Operate the loader and the hydraulic controls. Stop the engine. Check the fluid level. Add fluid as needed.

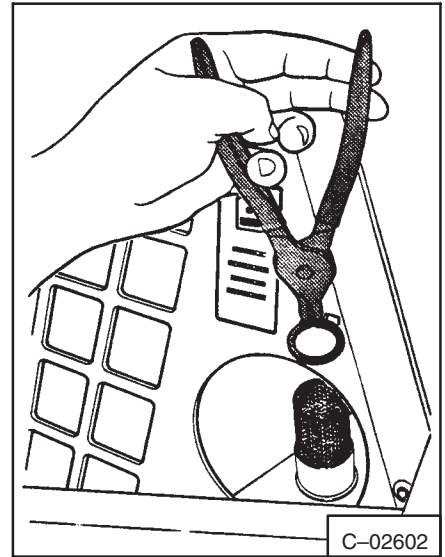

Fig. 1-38 100 Mesh Screen

1-6 FINAL DRIVE TRANSMISSION (Chaincase)

The chaincase is filled with the same type of fluid as the hydraulic/hydrostatic reservoir for chain lubrication (See Section 8 for the correct fluid specification).

1-6.1 Checking Chaincase Fluid

1. Put the loader on a level surface. Stop the engine.
2. Remove the plug (Fig. 1-39, Item 1) at the front of the chaincase housing.
3. Add fluid through the check plug hole until the fluid flows from the check plug hole.
4. Install the plug and tighten.

1-7 SPARK ARRESTOR MUFFLER

IMPORTANT

This loader is factory equipped with a U.S.D.A. Forestry Service approved spark arrestor muffler.

It is necessary to do maintenance on this spark arrestor muffler to keep it in working condition. The spark arrestor muffler must be serviced by dumping the spark chamber every 100 hours of operation.

If this machine is operated on flammable forest, brush or grass covered land, it must be equipped with a spark arrestor attached to the exhaust system and maintained in working order. Failure to do so will be in violation of California State Law, Section 4442, PRC.

Make reference to local laws and regulations for spark arrestor requirements.

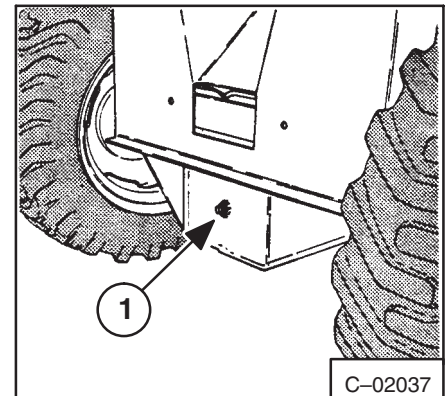

Fig. 1-39 Chaincase Plug

1-7.1 Cleaning the Spark Arrestor Muffler

1. Stop the engine. Open the rear door.

- Remove the plug(s) at the bottom of the muffler (540 – Fig. 1–40) (543 – Fig. 1–41).

⚠ WARNING

Never use machine in atmosphere with explosive dust or gases or where exhaust can contact flammable material. Failure to obey warnings can cause injury or death.

W-2068-1285

- Start the engine. Hold a piece of wood over the exhaust outlet for about 10 seconds to force the exhaust gases through the muffler plug(s).
- Stop the engine. Install the plug(s) and tighten. Close the rear door.

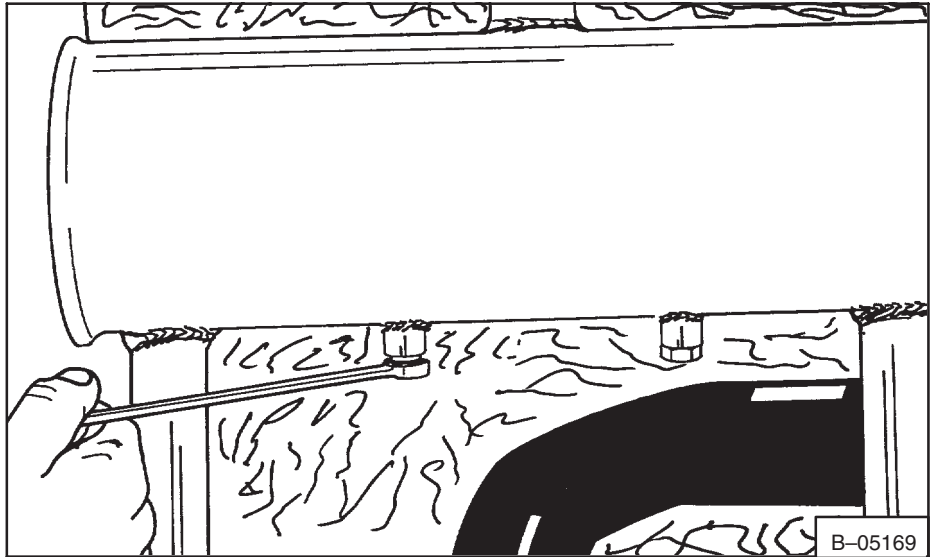

Fig. 1–40 Muffler Plug Location (540)

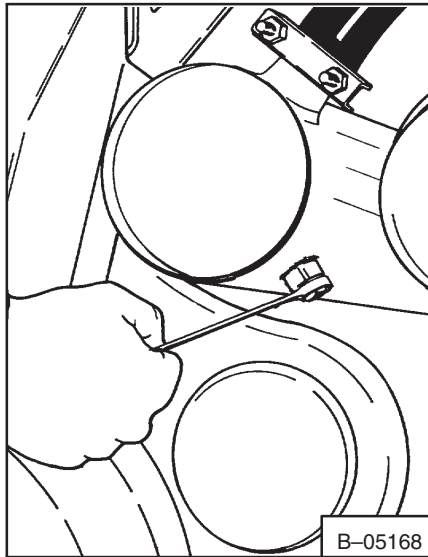

Fig. 1–41 Muffler Plug Location (543)

1–8 OPERATOR GUARD

The Bobcat loader has an operator guard (ROPS & FOPS) as standard equipment. The ROPS & FOPS protects the operator from rollover and falling objects.

⚠ WARNING

Never modify operator cab by welding, grinding, drilling holes or adding attachments unless instructed to do so by Melroe Company. Changes to the cab can cause loss of operator protection from rollover and falling objects, and result in injury or death.

W-2069-1285

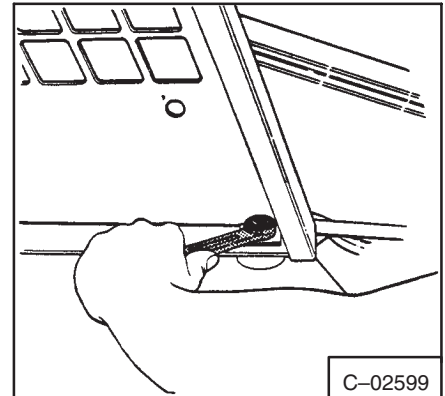

Fig. 1–42 Checking Guard Nuts

Always make sure the operator guard fastening bolts and nuts are tight (Fig. 1–42).

NOTE: See Section 5 for Raising and Lowering the Operator Guard.

1–9 LUBRICATION OF THE LOADER

1–9.1 Lubrication of the Loader

Lubricate the Bobcat loader as specified in the service Schedule on Page 1–3 for the best performance of the loader.

See figure 1-43 for the location of the grease fittings. Always use a good lithium based multi-purpose grease when you lubricate the Bobcat loader. Apply grease until the extra grease shows.

Grease the pivot bearings (Fig. 1-44 & 1-45) every 500 hours of loader operation.

1-10 TRANSPORTING THE BOBCAT LOADER

1-10.1 Loading the Bobcat Loader

Steel ramps are available to be used to load the Bobcat loader onto a transport vehicle.

⚠ WARNING

Use steel loading ramps when loading the Bobcat loader onto a transport vehicle. DO NOT use wooden planks.

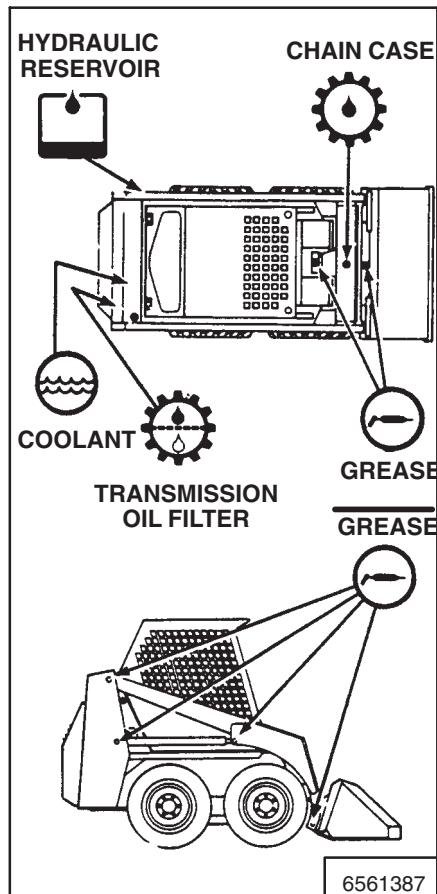

Fig. 1-43 Lubrication Chart

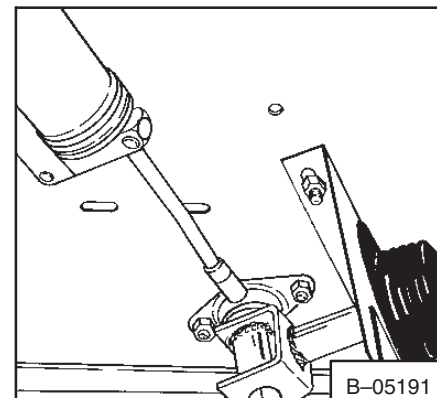

Fig. 1-44 Lubrication of Pivot Bearing

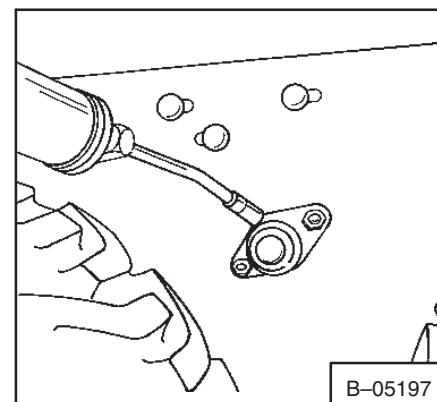

Fig. 1-45 Lubrication of Pivot Bearing

A loader with an empty bucket or no attachment must be loaded backwards onto the transport vehicle (Fig. 1-46).

1-10.2 Fastening the Loader to the Transport Vehicle

1. Lower the bucket or attachment to the floor and stop the engine.
2. Engage the parking brake.
3. Install the chains to hold the Bobcat loader in position to prevent it from moving during sudden stops or when going up or down slopes.

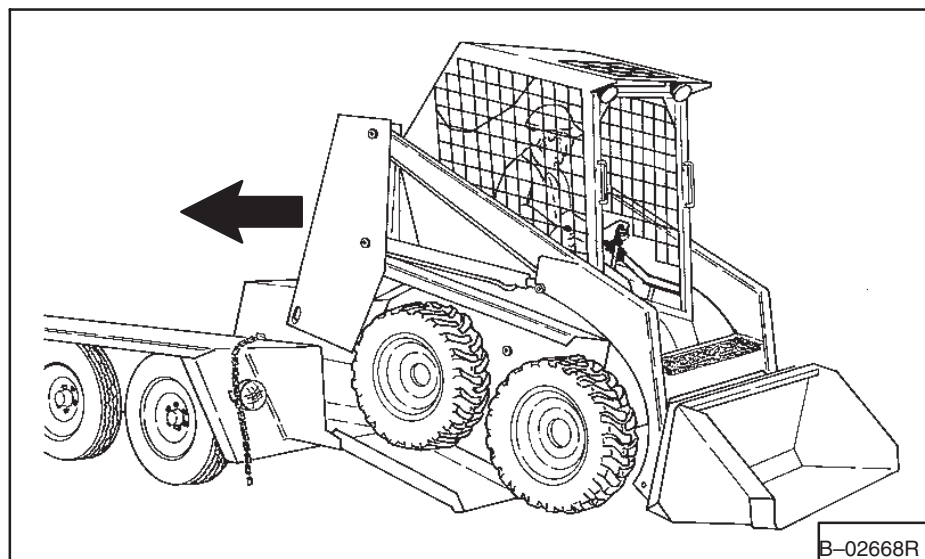

Fig. 1-46 Loading the Bobcat Loader

- Put a chain through the axle gusset and fasten to the Bobcat loader and to the transport vehicle (Fig. 1-47).
- Fasten the chains, one in each upright cutout, to the loader and to the transport vehicle (Fig. 1-48).

! WARNING

Never work on a machine with the lift arms up unless the lift arms are secured by an approved lift arm support device. Failure to use an approved lift arm support device can allow the lift arms or attachment to fall and cause injury or death. W-2059-0598

1-11 LIFT ARM STOP

- Two persons are needed to install or remove the lift arm stop. One person must be in the operator's seat, with the seat belt fastened, and the second person is to install the lift arm stop.
- Start the engine and raise the lift arms all the way up.
- Have the second person install the lift arm stop over the rod of one of the lift cylinders (Fig. 1-49).
- Make sure the lift arm stop is tight against the cylinder rod. Lower the lift arms until the stop is held between the lift arms and the lift cylinder.
- Stop the engine.

! WARNING

Service lift arm support device if damaged or if parts are missing. Using a damaged lift arm support or with missing parts can cause lift arms to drop causing injury or death. W-2271-1197

1-12 STOPPING THE BOBCAT LOADER

When you are stopping and leaving the Bobcat loader, use the following procedure:

- Stop the Bobcat loader on level ground.
- Lower the lift arms all the way down and put the edge of the bucket on the ground.
- Pull the throttle all the way backward to decrease the engine RPM. Turn the key switch to the "OFF" position.
- Engage the parking brake.
- Lift the seat bar and disconnect the seat belt.
- Make sure the hydraulic controls are in the locked position when the seat bar is raised.
- Remove the key from the switch to prevent the operation of the Bobcat loader by personnel other than the approved operator.

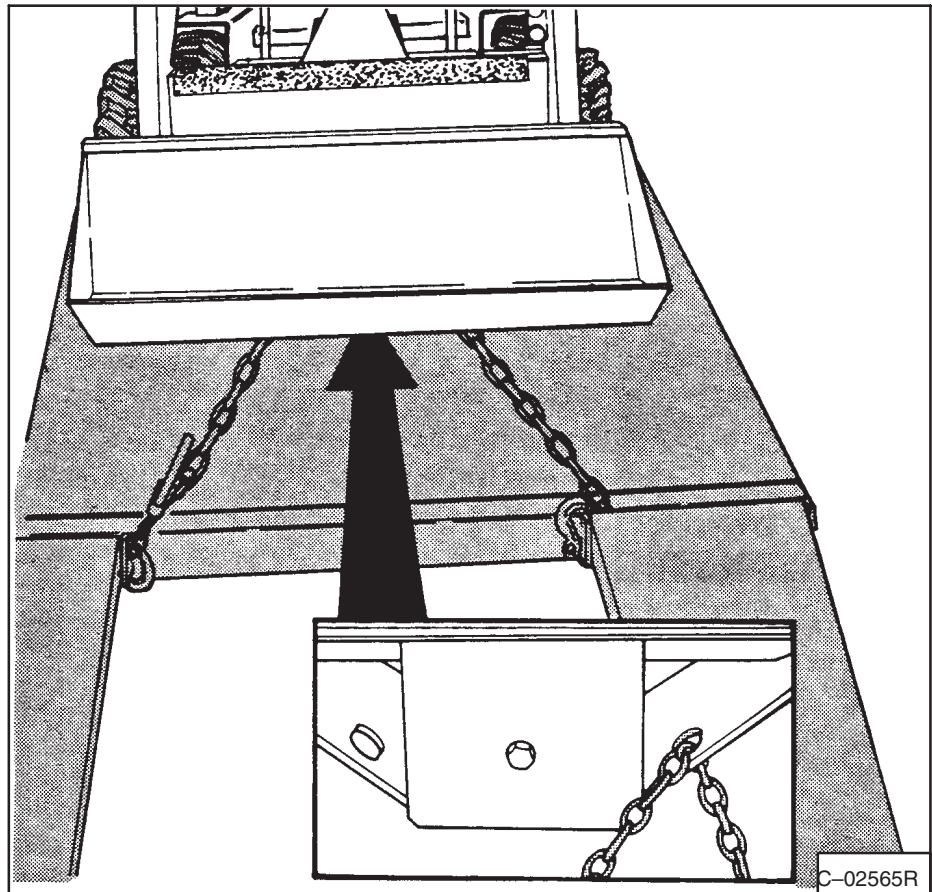

Fig. 1-47 Installing Hold-down Chains

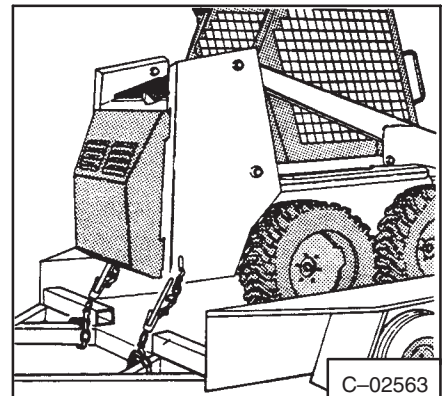

Fig. 1-48 Fastening the Loader

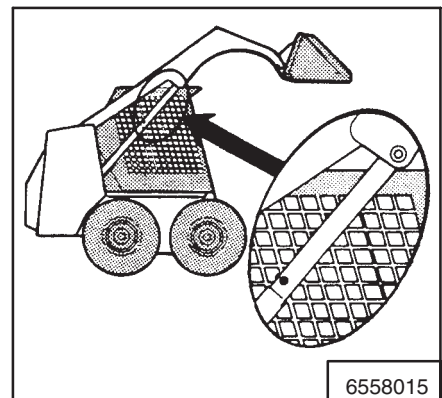

Fig. 1-49 Lift Arm Stop

HYDRAULIC SYSTEM

	Paragraph Number	Page Number
CONTROL PEDAL, LINKAGE AND LOCKS	2-10	2-27
HYDRAULIC CONTROL VALVE	2-3	2-3
HYDRAULIC/HYDROSTATIC RESERVOIR	2-7	2-23
HYDRAULIC PUMP	2-4	2-10
HYDRAULIC SYSTEM INFORMATION .	2-2	2-2
LIFT CYLINDERS	2-5	2-15
10 MICRON FILTER BY-PASS VALVE ..	2-9	2-26
OIL COOLER	2-8	2-24
TILT CYLINDER	2-6	2-21
TROUBLESHOOTING	2-1	2-1

HYDRAULIC SYSTEM



WARNING

DO NOT service the Bobcat loader without instructions or taking the necessary safety precautions. Before working on the loader, see the warnings and instructions at the beginning of this Service Manual. After making the repair or adjustment, always check the function of the loader. Failure to obey warnings may cause injury or death.



bobcat[®]

HYDRAULIC FLOW CHART

540

543

HYDRAULIC FLOW CHART

540
543

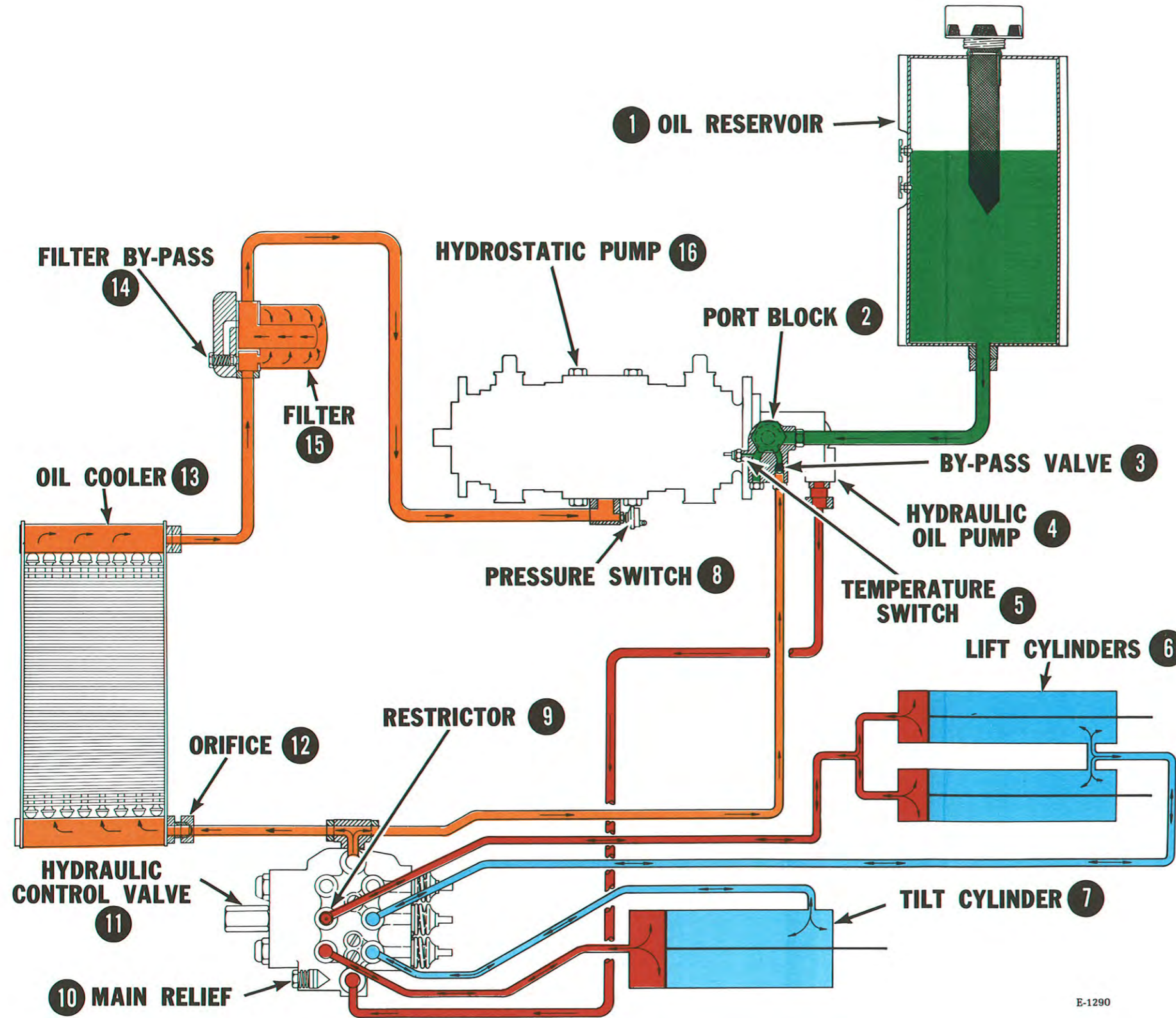

- ① OIL RESERVOIR, System Cap.: 6 Gal. [23 L] Working Cap.: 4 Gal. [15 L]
 - ② PORT BLOCK
 - ③ BY-PASS VALVE. 78-96 PSI [537-662 kPa]
 - ④ HYDRAULIC OIL PUMP, 8.3 GPM [31,4 L/m] at 2500 RPM
 - ⑤ TEMPERATURE SWITCH, 220-232°F [104-111°C]
 - ⑥ LIFT CYLINDERS
 - ⑦ TILT CYLINDER
 - ⑧ PRESSURE SWITCH, 23 - 27 PSI [158 - 186 kPa]
 - ⑨ RESTRICTOR, .125 (3,175 mm) Dia.
 - ⑩ MAIN RELIEF, (1575 - 1675 PSI [10859 - 11549 kPa] Measured at Aux. Quick Couplers)
 - ⑪ HYDRAULIC CONTROL VALVE
 - ⑫ ORIFICE
 - ⑬ OIL COOLER
 - ⑭ FILTER BY-PASS, 72 PSI [496 kPa]
 - ⑮ FILTER, 10 Micron
 - ⑯ HYDROSTATIC PUMP
- RED High Pressure
■ BLUE Low Pressure
■ GREEN Case Drain & Reservoir
■ ORANGE ---- Charge Pressure

This as a preview PDF file from best-manuals.com



Download full PDF manual at best-manuals.com