

1640, 1840, 2040 and 2040 S Tractors

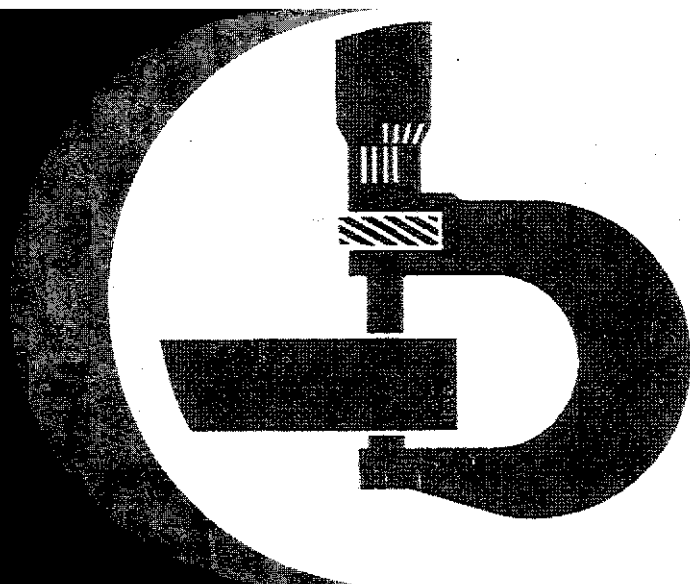

John Deere Werke Mannheim
John Deere Ibérica S.A. Getafe
TM4363 (Aug-86)

PRINTED IN GERMANY
ENGLISH

1640, 1840, 2040 and 2040 S Tractors
Technical Manual
TM-4363

CONTENTS

SECTION 10 – GENERAL

- Group 00 – Specifications and special tools
- Group 05 – Pre-delivery, delivery and after-sales inspections
- Group 10 – Lubrication and periodic service
- Group 15 – Engine and tractor tune-up
- Group 20 – Tractor separation (tractors without increased lifting capacity)
- Group 25 – Tractor separation (tractors with increased lifting capacity)

SECTION 20 – ENGINE

- Group 00 – Specifications
- Group 05 – Radiator

SECTION 30 – FUEL AND AIR INTAKE SYSTEM

- Group 00 – Specifications and special tools
- Group 05 – Diagnosing malfunctions
- Group 10 – Fuel tank and water trap
- Group 15 – Cold weather starting aids
- Group 20 – Speed control linkage
- Group 25 – Air cleaner

SECTION 40 – ELECTRICAL SYSTEM

- Group 00 – Specifications and special tools
- Group 05 – Description, diagnosing malfunctions and tests
- Group 10 – Wiring harnesses
- Group 15 – Controls and instruments
- Group 20 – Lighting system
- Group 25 – Wiring diagrams
- Group 30 – Starting motor
- Group 35 – Alternator

SECTION 50 – POWER TRAIN

- Group 00 – Specifications and special tools
- Group 05 – Description, operation and lubricating system
- Group 10 – Clutch operating linkages
- Group 15 – Engine clutches
- Group 20 – Hi-Lo shift unit
- Group 25 – Creeper transmission
- Group 30 – Transmission shift linkage
- Group 35 – Synchronized transmission and transmission oil pump
- Group 40 – Collar shift transmission and transmission oil pump
- Group 45 – Differential
- Group 50 – Final drives
- Group 55 – Independent PTO
- Group 60 – Continuous-running PTO
- Group 61 – Front PTO
- Group 65 – Mechanical front wheel drive

Copyright © by
DEERE & COMPANY
European Office
D 68 Mannheim
All rights reserved

CONTENTS (Contd.)**SECTION 60 – STEERING SYSTEM AND BRAKES**

- Group 00 – Specifications and special tools
- Group 05 – Hydrostatic steering (operating pressure: 12000 kPa; 120 bar; 1740 psi)
- Group 06 – Hydrostatic steering (operating pressure: 15000 kPa; 150 bar; 2180 psi)
- Group 10 – Power steering
- Group 15 – Manual steering
- Group 20 – Brakes

SECTION 70 – HYDRAULIC SYSTEM

- Group 00 – Specifications and special tools
- Group 05 – Description, diagnosing malfunctions and pressure tests
- Group 10 – Oil reservoir, filter, valves and oil cooler
- Group 15 – Hydraulic pumps
- Group 20 – Rockshaft
- Group 21 – Front hitch
- Group 25 – Selective control valves (spool type)
- Group 30 – Selective control valves (poppet valve type)
- Group 35 – Hose couplers
- Group 40 – Remote cylinder
- Group 45 – Selective control valves (for tractors manufactured in Spain)

SECTION 80 – MISCELLANEOUS

- Group 00 – Specifications and special tools
- Group 05 – Front axle
- Group 10 – Belt pulley
- Group 15 – Front and rear wheels
- Group 20 – Axla trailer hitch

SECTION 90 – OPERATOR'S CAB

- Group 00 – Specifications and special tools
- Group 05 – Air conditioning system
- Group 10 – Cab ventilation and heating
- Group 15 – Operator's seats
- Group 20 – OPU cab
- Group 25 – SG2 cab
- Group 30 – Roll guard

Section 10

General

CONTENTS OF THIS SECTION

GROUP 00 – SPECIFICATIONS AND SPECIAL TOOLS

	Page
Specifications	00-3
Serial numbers	00-3
Model numbers	00-3
Engine	00-3
Engine clutch	00-4
Cooling system	00-4
Fuel system	00-5
Electrical system	00-5
Synchronized transmission	00-6
Collar shift transmission	00-6
Hi-Lo shift unit	00-6
Creeper transmission	00-6
Differential and final drives	00-7
Differential lock	00-7
PTO	00-7
Mechanical front wheel drive	00-7
Hydrostatic steering	00-8
Power steering	00-8
Manual steering	00-8
Foot brakes	00-8
Handbrake	00-8
Hydraulic system	00-8
Capacities	00-8
Travel speeds	00-9
Front and rear wheels	00-9
Dimensions and weights	00-9
Predelivery, delivery and after-sales inspections	00-10
Lubrication and service	00-11
Tune-up	00-13
Tractor separation	00-14
Standard torques	00-16
Special tools	00-18

GROUP 05 – PREDELIVERY, DELIVERY AND AFTER-SALES INSPECTIONS

	Page
Tractor storage	05-1
Predelivery inspection	05-2
Delivery inspection	05-11
After-sales inspection	05-11

GROUP 10 – LUBRICATION AND SERVICE

Lubrication and service	10-1
-----------------------------------	------

GROUP 15 – TUNE-UP

Preliminary engine testing	15-1
Dynamometer test	15-1
Testing compression pressure	15-2
Tune-up	15-2
Checking tractor operation	15-7
Standard torques	15-8

GROUP 20 – TRACTOR SEPARATION (Tractors without Increased Lifting Capacity)

Separating between engine and tractor front end	20-1
Removal and installation of engine	20-7
Removal and installation of clutch housing	20-11
Removal and installation of final drives	20-15
Removal and installation of rockshaft	20-21
Removal and installation of operator's cab	20-24

**GROUP 25 – TRACTOR SEPARATION (Tractors
with Increased Lifting Capacity)**

	Page
Special tools	25-1
Torques for hardware	25-5
Capacities	25-7
Standard torques	25-7
Important notes	25-9
Removing tractor front end	25-10
Installing tractor front end	25-18
Separating between engine and clutch housing	25-20
Joining tractor between engine and clutch housing	25-28
Removing engine	25-31
Installing engine	25-32
Removing clutch housing	25-33
Installing clutch housing	25-34
Removing transmission	25-35
Installing transmission	25-41
Removing final drives	25-44
Installing final drives	25-52
Removing rockshaft	25-55
Installing rockshaft	25-56
Removing front wheel drive axle	25-58
Installing front wheel drive axle	25-60
Removing SG2 cab	25-63
Installing SG2 cab	25-73
Removing front hitch	25-76
Installing front hitch	25-79
Removing front PTO	25-81
Installing front PTO	25-83

Group 00

Specifications and Special Tools

Specifications

Serial Numbers

The engine serial number is stamped into the plate located on the lower front right-hand side of the cylinder block.

NOTE: When ordering engine parts, quote all digits of serial number stamped on the plate.

The plate showing the tractor serial number is located on the right-hand side of the front axle carrier.

NOTE: When ordering tractor spare parts (excluding engine parts), quote all numbers and letters of serial number stamped on the plate.

A plate showing the tractor type, transmission serial number, cone point measurement etched into pinion face of differential drive shaft as well as reduction of differential is located on the right-hand side of the transmission case.

Model Numbers

The fuel injection pump, fuel injection nozzles, alternator, starting motor, hydrostatic steering valve, compressor of air conditioning system (when equipped) and hydraulic pump have model numbers to facilitate identification of different makes of a given unit.

Engine

Number of cylinders	4	
Cylinder liner bore	106.5 mm (4.19 in.)	
Stroke	110 mm (4.33 in.)	
Displacement	3920 cm ³ (239 cu.in.)	
Compression ratio		
1640, 1840 and 2040 up to engine serial no. 571869 CD and		
2040 S up to engine serial no. 547536 CD	16.8 : 1	
1640 and 2040 from engine serial no. 571870 CD and		
2040 S from engine serial no. 547537 CD	17.4 : 1	
Maximum torque		
1640 at 1200 rpm	205 Nm	150 ft-lb
1840 and 2040 at 1300 rpm	230 Nm	170 ft-lb
2040 S at 1400 rpm	245 Nm	180 ft-lb

Firing order.....		1 - 3 - 4 - 2
Valve clearance (engine hot or cold)		
Intake valve.....	.035 mm	0.014 in.
Exhaust valve.....	.045 mm	0.018 in.
Fast idle speed.....		2610 to 2660 rpm
Slow idle speed.....		700 to 800 rpm
Rated engine speed.....		2500 rpm
Working speed range		
1640.....		1200 to 2500 rpm
1840 and 2040.....		1300 to 2500 rpm
2040 S.....		1400 to 2500 rpm
Flywheel horsepower at engine rated speed – 2500 rpm		
According to DIN 70020, 1640.....	.46 kW	62 hp
1840 and 2040.....	.51 kW	70 hp
2040 S.....	.55 kW	75 hp
PTO* horsepower at engine rated speed – 2500 rpm		
According to DIN 70020, 1640.....	.41 kW	56 hp
1840 and 2040.....	.46 kW	63 hp
2040 S.....	.50 kW	68 hp
According to DIN SAE J816b, 1640.....	.40 kW	54 hp
1840 and 2040.....	.45 kW	60 hp
2040 S.....	.48 kW	65 hp

Lubrication system..... Full internal force feed system, with full flow filter

Engine Clutch..... Single dry disk with torsion damper or dual-stage dry disk, foot-operated

Cooling System

Type..... Pressurized system with centrifugal pump

Temperature regulation..... Thermostat

* With the engine run in (above 100 hours of operation) and having reached operating temperature (engine and transmission); measured by means of a dynamometer. Permissible variation $\pm 5\%$.

Fuel System

Type	Direct injection
Fuel injection pump timing to engine	TDC
Fuel injection pump type	Distributor type
1640	
Up to engine serial no. 531584 CD	Roto Diesel No. R 3443 F 630
From engine serial no. 531585 CD	Roto Diesel No. R 3443 F 980
1840 and 2040	
Up to engine serial no. 530063 CD	Roto Diesel No. R 3443 F 640
From engine serial no. 530064 CD	Roto Diesel No. R 3443 F 970
2040S	
Up to engine serial no. 531047 CD	Roto Diesel No. R 3443 F 140
From engine serial no. 531048 CD	Roto Diesel No. R 3443 F 950
Air cleaner	Dry-type air cleaner with secondary (safety) element

Electrical System

Batteries	2 x 12 volts, 55 Ah
Tractors with SG2 cab	2 x 12 volts, 55 or 66 Ah
Alternator with internal regulator	
Tractors without operator's cab	14 volts, 33 or 55 amps.
Tractors with operator's cab	14 volts, 55 amps.
Starting motor	12 volts, 3 kW (4 HP)
Battery terminal grounded	negative

Synchronized Transmission

Type	Synchronized transmission
Gear selections	8 forward and 4 reverse
Gear shifting	Two forward groups and one reverse group Synchronized forward and reverse shifting within groups

Collar Shift Transmission

Type	Helical gears
Gear selections	8 forward, 4 reverse speeds
Gear shifting	Two forward ranges, One reverse range

Hi-Lo Shift Unit

Type	Hydraulic gear reduction unit which can be shifted under load with "wet" multiple disk clutch and brake packs
Travel speed decreases in each gear by	Approx. 20 %
Shifting to reduced (Lo) speed	Preloaded cup springs
Shifting to normal (Hi) speed	Hydraulic

Creep Transmission

Type	Synchronized reduction unit
Travel speed decreases in low (I) and reverse ranges by	approx. 79 %
Shifting both ranges	Mechanical and not under load

Differential and Final Drives

Type of differential	Spiral bevel gears
Type of final drive	Planetary reduction drive

Differential Lock

Operation Hand or foot operated
 Disengage Will disengage automatically as soon as traction has equalized

PTO

INDEPENDENT PTO

Type Independent of transmission, can be engaged and disengaged under load
 PTO clutch Hydraulically operated "wet" disk clutch
 PTO brake Hydraulically operated "wet" disk brake

CONTINUOUS – RUNNING PTO

Type Independent of transmission, with engine dual stage clutch

PTO SPEEDS (in rpm)

Engine speed	540 rpm shaft	1000 rpm shaft
800	180* or 210**	335
2400* or 2040**	540	1000
2500	565* or 660**	1040
2660	600* or 705**	1110

Mechanical Front Wheel Drive

Type Engaged hydraulically, under full load with "wet" disk clutch
 Control Electrical/hydraulic solenoid switch
 Engagement Preloaded cup springs
 Disengagement Hydraulic

* Up to tractor serial no. 507867 L
 ** From tractor serial no. 507868 L

Hydrostatic Steering	Without mechanical linkage between steering valve and the front wheels
Power Steering	Hydraulically operated steering linkage
Manual Steering	Recirculating ball bearing type
Foot Brakes	Self-adjusting, hydraulically operated "wet" disk brakes
Handbrake	Mechanically operated band-type locking brake acting on the differential

Hydraulic System

Type	Closed center, constant pressure system		
Standby pressure*	19000 kPa	190 bar	2760 psi
Operating pressure**	17000 kPa	170 bar	2470 psi
Hydraulic pump	4 or 8-piston pump with variable displacement		

Capacities

Fuel tank			
Plastic tank	95 liters		25.1 U.S.gals.
Metal tank	90 liters		23.8 U.S.gals.
Cooling system			
Without operator's cab	13 liters		3.4 U.S.gals.
With operator's cab	15 liters		4.0 U.S.gals.
Engine crankcase			
Without filter change	8 liters		2.1 U.S.gals.
With filter change	8.5 liters		2.25 U.S.gals.
Transmission - Hydraulic system (including oil reservoir and oil cooler)			
Synchronized transmission			
Initial filling			
1640, 1840 and 2040	59 liters		15.6 U.S. gals.
1640 and 2040 with heavy-duty final drives and 2040 S. . .	64 liters		16.9 U.S. gals.
Oil change			
1640, 1840 and 2040	51 liters		13.5 U.S. gals.
1640 and 2040 with heavy-duty final drives and 2040 S. . .	56 liters		14.8 U.S. gals.

On tractors for Canada only:

* 15500 kPa	155 bar	2250 psi
** 14000 kPa	140 bar	2050 psi

Collar shift transmission

Initial filling

1640, 1840 and 2040	47 liters	12.4 U.S. gals.
1640 and 2040 with heavy-duty final drives	52 liters	13.75 U.S. gals.

Oil change

1640, 1840 and 2040	39 liters	10.3 U.S. gals.
1640 and 2040 with heavy-duty final drives	44 liters	11.6 U.S. gals.

Oil reservoir	4 liters	1.1 U.S. gals.
---------------	----------	----------------

Oil cooler	2 liters	0.5 U.S. gals.
------------	----------	----------------

Mechanical front wheel drive

Front axle housing

up to serial no. 449 999 L	5.3 liters	1.4 U.S. gals.
from serial no. 450 000 L	5.0 liters	1.3 U.S. gals.

Wheel hub housing, each

up to serial no. 449 999 L	0.75 liters	0.2 U.S. gals.
from serial no. 450 000 L	0.75 liters	0.2 U.S. gals.

Belt pulley	1 liter	0.3 U.S. gals.
-------------	---------	----------------

Travel Speeds see Operator's Manual

Front and Rear Wheels

Tires, tread widths, tire pressures and ballast weights see Operator's Manual

Dimensions and Weights see Operator's Manual

Predelivery, Delivery and After-Sales Inspections

ENGINE SPEEDS

Slow idle	700 to 800 rpm
Fast idle	2610 to 2660 rpm
Rated speed	2500 rpm

FAN BELT

The fan belt should have 19 mm (3/4 in.) flex with 90 N (20 lb) pull midway between crankshaft and alternator or water pump (use a spring scale).

COMPRESSOR BELT

The compressor belt should have 19 mm (3/4 in.) flex with 60 N (13 lb) pull midway between pulleys.

BATTERIES

Specific gravity at an electrolyte temperature of 20° C (68° F)

Normal and arctic conditions	1.28
Tropical conditions	1.23

CLUTCH OPERATING ASSY.

Tractors without Cab or with OPU

Clutch pedal free travel	approx. 25 mm 1 in.
--------------------------------	------------------------

Tractors with SG2 Cab

Slave cylinder operating rod, stroke	8.5 to 12.0 mm 5/16 to 15/32 in.
--	-------------------------------------

FRONT WHEEL TOE-IN

Tractors without front wheel drive	3 to 6 mm	0.12 to 0.25 in.
Tractors with MFWD	0 to 3 mm	0 to 0.12 in.

TORQUES FOR HARDWARE

Front wheel rim to hub		
Tractors without front wheel drive	180 Nm	130 ft-lb
Tractors with MFWD	300 Nm	220 ft-lb
Axle knees to axle center, cap screws	400 Nm	300 ft-lb

Tractors with Hydrostatic Steering

Tie rod clamps, cap screws		
Cap screw (M 10)	55 Nm	40 ft-lb
Cap screw (M 12)	90 Nm	65 ft-lb
Tie rod tube, cap screw	55 Nm	40 ft-lb

Tractors with Power Steering or Manual Steering

Outer clamp of tie rod, cap screw	90 Nm	65 ft-lb
Inner clamp of tie rod, cap screw	55 Nm	40 ft-lb

Rear wheels		
Rear wheels to axle	400 Nm	300 ft-lb
Wheel disk to hub (rack-and-pinion axle)	400 Nm	300 ft-lb
4-post roll guard		
Roll guard to fender, cap screws	120 Nm	85 ft-lb
U-bolt hex. nuts	130 Nm	95 ft-lb
2-post roll guard		
To final drive housings, cap screws	230 Nm	170 ft-lb
Both supports to crossbar, cap screws	230 Nm	170 ft-lb
Rear wheel fenders to final drive housings, hex. nuts	130 Nm	95 ft-lb

Lubrication and Service

CAPACITIES

Engine crankcase		
Without filter change	8 liters	2.10 U.S. gals.
With filter change	8.5 liters	2.25 U.S. gals.
Cooling system		
Without cab	13 liters	3.4 U.S. gals.
With cab	15 liters	4.0 U.S. gals.
Transmission — Hydraulic system (including oil reservoir and oil cooler)		
Synchronized transmission		
Initial filling		
1640, 1840 and 2040	59 liters	15.6 U.S. gals.
1640 and 2040 with heavy-duty final drives and 2040 S	64 liters	16.9 U.S. gals.
Oil change		
1640, 1840 and 2040	51 liters	13.5 U.S. gals.
1640 and 2040 with heavy-duty final drives and 2040 S	56 liters	14.8 U.S. gals.
Collar shift transmission		
Initial filling		
1640, 1840 and 2040	47 liters	12.4 U.S. gals.
1640 and 2040 with heavy-duty final drives	52 liters	13.75 U.S. gals.
Oil change		
1640, 1840 and 2040	39 liters	10.3 U.S. gals.
1640 and 2040 with heavy-duty final drives	44 liters	11.6 U.S. gals.
Oil reservoir	4 liters	1.1 U.S. gals.
Oil cooler	2 liters	0.5 U.S. gals.
Mechanical front wheel drive		
Front axle housing		
up to serial no. 449 999 L	5.3 liters	1.4 U.S. gals.
from serial no. 450 000 L	5.0 liters	1.3 U.S. gals.
Wheel hub housing, each		
up to serial no. 449 999 L	0.75 liters	0.2 U.S. gals.
from serial no. 450 000 L	0.75 liters	0.2 U.S. gals.
Belt pulley	1 liter	0.3 U.S. gals.

SERVICE INTERVALS

Checking crankcase oil level	every	10 hours
Changing engine oil	every	200 hours
Changing engine oil filter	every	200 hours
Checking transmission/hydraulic system oil level	every	50 hours
Changing transmission/hydraulic system oil filter	every	500 hours
Changing transmission/hydraulic oil	every	1000 hours
Changing hydrostatic steering filter	every	1000 hours
Cleaning hydraulic pump strainer	every	1000 hours
Checking FWD oil level	every	100 hours
FWD oil change	every	1000 hours
Cleaning and packing front wheel bearings	every	1000 hours
Lubricating grease fittings		
Universal joints of FWD	every	50 hours
In wet and muddy conditions	every	10 hours
Front axle and front axle bearings	every	50 hours
In wet and muddy conditions	every	10 hours
Clutch throw-out bearing grease fitting (when equipped)	every	100 hours
Rear axle bearings	every	500 hours
In wet and muddy conditions	every	10 hours
Three point hitch	every	200 hours

Tune-Up

PTO horsepower* at 2500 rpm rated engine speed

According to DIN 70020, 164041 kW	56 hp
1840 and 204046 kW	63 hp
2040 S.50 kW	68 hp
According to SAE J 816 b, 164040 kW	54 hp
1840 and 204045 kW	60 hp
2040 S.48 kW	65 hp

Slow idle 700 to 800 rpm

Fast idle 2610 to 2660 rpm

Rated engine speed 2500 rpm

Air intake system vacuum 3.5 to 6.0 kPa 35 to 60 mbar 14 to 25 in.
water head

Air cleaner restriction warning
switch closes at a vacuum of 5.5 to 6.5 kPa 55 to 65 mbar 22 to 26 in.
water head

Radiator cap high pressure valve
opens at.40 to 50 kPa 0.4 to 0.5 bar 6 to 7 psi

Radiator cap low pressure valve
opens at.0 to 4 kPa 0 to 0.4 bar 0 to 0.6 psi

FAN BELT

Fan belt should have 19 mm (3/4 in.) flex with 90 N (20 lb) pull midway between crankshaft and alternator or water pump (use a spring scale).

COMPRESSOR BELT

Compressor belt should have 19 mm (3/4 in.) flex with 60 N (13 lb) pull midway between pulleys.

* With the engine run in (more than 100 hours of operation) and having reached operating temperature (engine and transmission); measured by means of a dynamometer. Permissible variation $\pm 5\%$.

Tractor Separation

TORQUES FOR HARDWARE (Tractors without Increased Lifting Capacity)

Front axle carrier to engine block		
front attaching cap screws (4 used)	230 Nm	170 ft-lb
rear attaching cap screws (2 used)	180 Nm	130 ft-lb
Front axle carrier to oil pan, cap screws	400 Nm	300 ft-lb
Hydraulic pump drive shaft, cap screws.	50 Nm	35 ft-lb
Jointed shaft flange to front axle		
drive hub (tractors with MFWD), cap screws		
up to serial no. 449 999 L	35 Nm	25 ft-lb
from serial no. 450 000 L	75 Nm	55 ft-lb
Drag link* to bell crank or steering arm, slotted nut**	75 Nm	55 ft-lb
Clutch housing to engine block		
cap screws	230 Nm	170 ft-lb
hex. nuts	230 Nm	170 ft-lb
Oil pan to clutch housing, cap screws	230 Nm	170 ft-lb
Clutch housing to transmission, cap screws	160 Nm	120 ft-lb
Transmission case drain plugs	135 Nm	100 ft-lb
Retainer of hydraulic lines to clutch housing, cap screw.	45 Nm	32 ft-lb
Final drive housings to transmission case, cap screws	120 Nm	85 ft-lb
Rockshaft housing to transmission case, cap screws	120 Nm	85 ft-lb
Rear wheels to rear axle	400 Nm	300 ft-lb
Wheel disk to hub (on tractors equipped with rack-and-pinion axle).	400 Nm	300 ft-lb
Rear wheel fenders to final drive housings, hex. nuts	130 Nm	95 ft-lb
4-post roll guard		
Roll guard to fender, cap screws	120 Nm	85 ft-lb
U-bolt hex. nuts	130 Nm	95 ft-lb
2-post roll guard		
to final drive housings, cap screws	230 Nm	170 ft-lb
both supports to crossbar, cap screws	230 Nm	170 ft-lb





* On tractors with power or manual steering

** **NOTE:** If cotter pin cannot be inserted when tightening to the specified torque, turn nut to next slot and secure with cotter pin.

Basic weight to front axle carrier, cap screws	400 Nm	300 ft-lb
Drawbar to transmission case, cap screws	120 Nm	85 ft-lb
OPU Cab		
Cab to rubber bearing block, slotted nuts*	10 to 20 Nm	7 to 14 ft-lb
Rubber bearing block to bearing and pivot brackets, cap screws	50 Nm	35 ft-lb
Bearing pivot bracket to final drive housing, cap screws	100 Nm	70 ft-lb
Bearing bracket to battery box, cap screws	50 Nm	35 ft-lb
Battery box to flywheel housing, upper cap screw	200 Nm	145 ft-lb
lower cap screws	100 Nm	70 ft-lb
SG2 Cab		
Cab to rubber bearing blocks, hex. nuts	200 Nm	145 ft-lb

* *NOTE: Insert cotter pin within specified torque.*

Standard Torques

Recommended torques in Nm and ft-lb for UNC and UNF cap screws				
Head marking (Identifying strength)	  or 10.9*		  or 12.9**	
Thread-O.D. (in.)	Nm	ft-lb	Nm	ft-lb
1/4	15	10	20	15
5/16	30	20	40	30
3/8	50	35	70	50
7/16	80	55	110	80
1/2	120	85	170	120
9/16	180	130	240	175
5/8	230	170	320	240
3/4	400	300	580	425
7/8	600	445	930	685
1	910	670	1400	1030
1-1/8	1240	910	1980	1460
1-1/4	1700	1250	2800	2060

NOTE: A variation of $\pm 10\%$ is permissible for all torques indicated in this chart.

Torque figures indicated above and in the Specification sections of this manual are valid for non-greased or non-oiled threads and heads unless otherwise specified. Therefore, do not grease or oil bolts or cap screws unless otherwise specified in this manual.

* Tempered steel high strength bolts and cap screws

** Tempered steel extra high strength bolts and cap screws

Recommended torques in Nm and ft-lb for metric cap screws						
Head marking (identifying) strength)	8.8*		10.9**		12.9***	
Thread-O.D. (mm)	Nm	ft-lb	Nm	ft-lb	Nm	ft-lb
M5	7	5	9	6.5	10	8.5
M6	10	8.5	15	10	20	15
M8	30	20	40	30	40	30
M10	50	35	80	60	90	70
M12	100	75	140	100	160	120
M14	160	120	210	155	260	190
M16	240	175	350	260	400	300
M20	480	355	650	480	780	575
M24	820	605	1150	850	1350	995
M30	1640	1210	2250	1660	2700	1990
M36	2850	2110	4000	2950	4700	3465

NOTE: A variation of $\pm 10\%$ is permissible for all torques indicated in this chart.

Torque figures indicated above and in the Specification sections of this manual are valid for non-greased or non-oiled threads and heads unless otherwise specified. Therefore, do not grease or oil bolts or cap screws unless otherwise specified in this manual.

- * Regular bolts and cap screws
- ** Tempered steel high strength bolts and cap screws
- *** Tempered steel extra high strength bolts and cap screws

Recommended torques in Nm and ft-lb for pipe and hose connections				
Thread size	with O-rings		with cone	
	Nm	ft-lb	Nm	ft-lb
3/8-24 UNF	7.5	5.5	8	6
7/16-20 UNF	10	7	12	9
1/2-20 UNF	12	9	15	11
9/16-18 UNF	15	11	25	18
3/4-16 UNF	25	20	45	35
7/8-14 UNF	40	30	60	45
1-1/16-12 UNC	60	45	100	75
1-3/16-12 UNC	70	50	120	90
1-5/16-12 UNC	80	60	140	105
1-5/8-12 UNC	110	80	190	140
1-7/8-12 UNC	150	110	220	160

Special Tools

Tune-Up

Tool	Description and Part No.	Use
 <p>L30515A</p>	<p>Pressure gauge set FKM 10002</p>	<p>Measuring air intake system vacuum</p>

Fig. 1 -- Pressure Gauge Set

 <p>L106551</p>	<p>Vacuum gauge FKM 10242</p>	<p>Measuring air intake system vacuum</p>
--	-----------------------------------	---

Fig. 2 – Vacuum Gauge

Tools	Description and Part No.	Use
Tractor Separation		
	1 Lifting eye, straight JD-244-1	Tractor separation
	2 Lifting eye, bent JD-244-2	

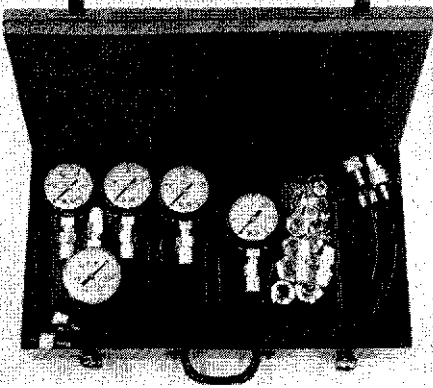
L23985

Fig. 3 – Lifting Eyes, Straight and Bent

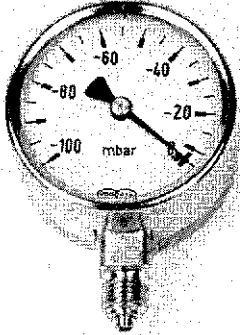
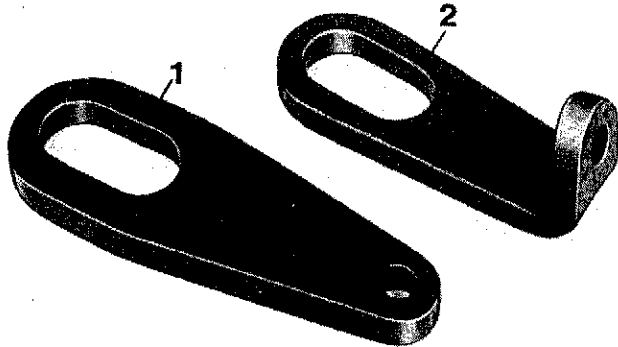
Tool

Description and Part No.

Use

KJD 10129

Separating between engine and clutch housing on tractors with SG2 cab

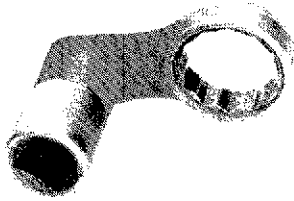

L107001

Fig. 4 – Special Spanner

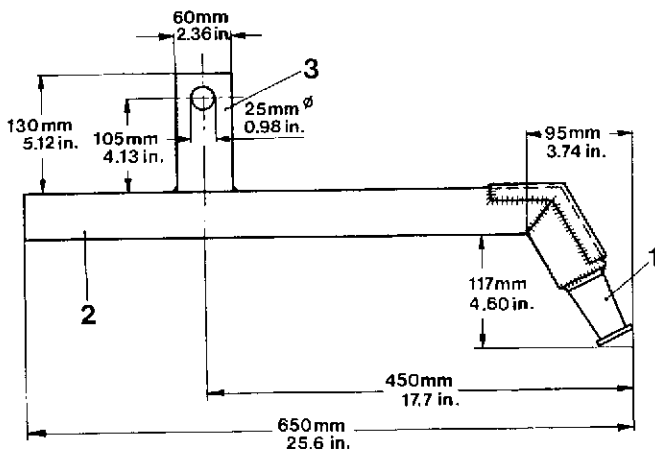

Removing rockshaft (tractors with OPU)

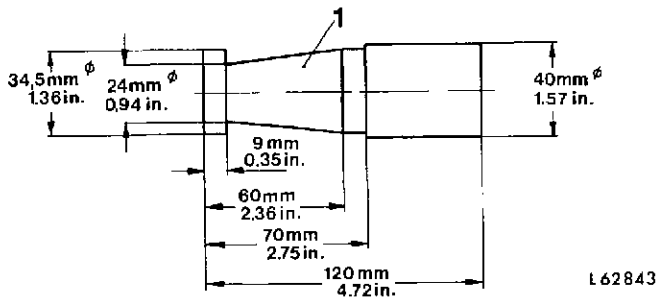
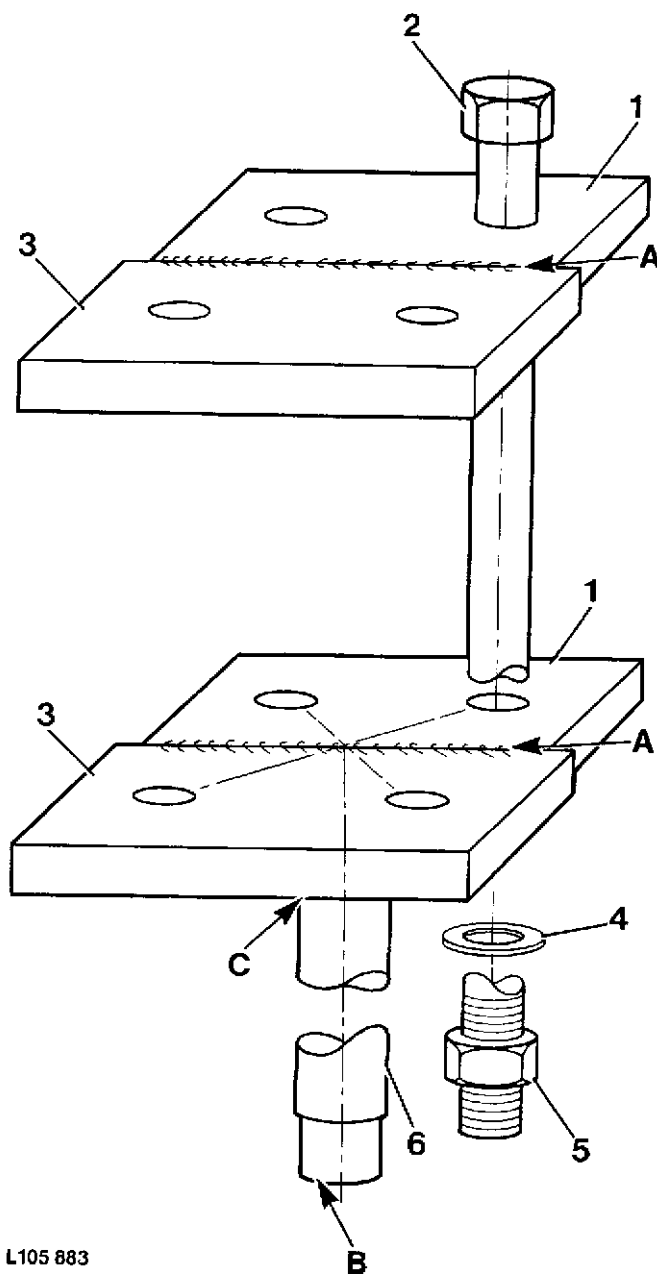

Fig. 5 – Tool for Removing Rockshaft (Self-Manufacture)

- 1 Round material 40 x 120 mm (1.57 x 4.72 in.)
- 2 Pipe 48 x 3.5 x 650 mm (1.89 x 0.14 x 25.6 in.)
- 3 Flat metal 60 x 12 x 130 mm (2.36 x 0.47 x 5.12 in.)



L105 883

Fig. 6 – Holding Device (Self-Manufacture), Removal of Final Drive Assemblies

- | | | | |
|---|---|---|--|
| A | Weld both retaining plates together | B | Adapter lug diameter to fit bore of trolley jack |
| C | Weld round steel in center of both plates | 4 | Washer 14 H 1698 (2 used) |
| 1 | Retaining plate T 25671 (2 used) | 5 | Hex. nut 14 H 1039 (2 used) |
| 2 | Cap screw L 29785 (2 used) | 6 | Round steel 50 x 250 mm (1.97 x 9.84 in.) |
| 3 | Retaining plate T 32429 (2 used) | | |

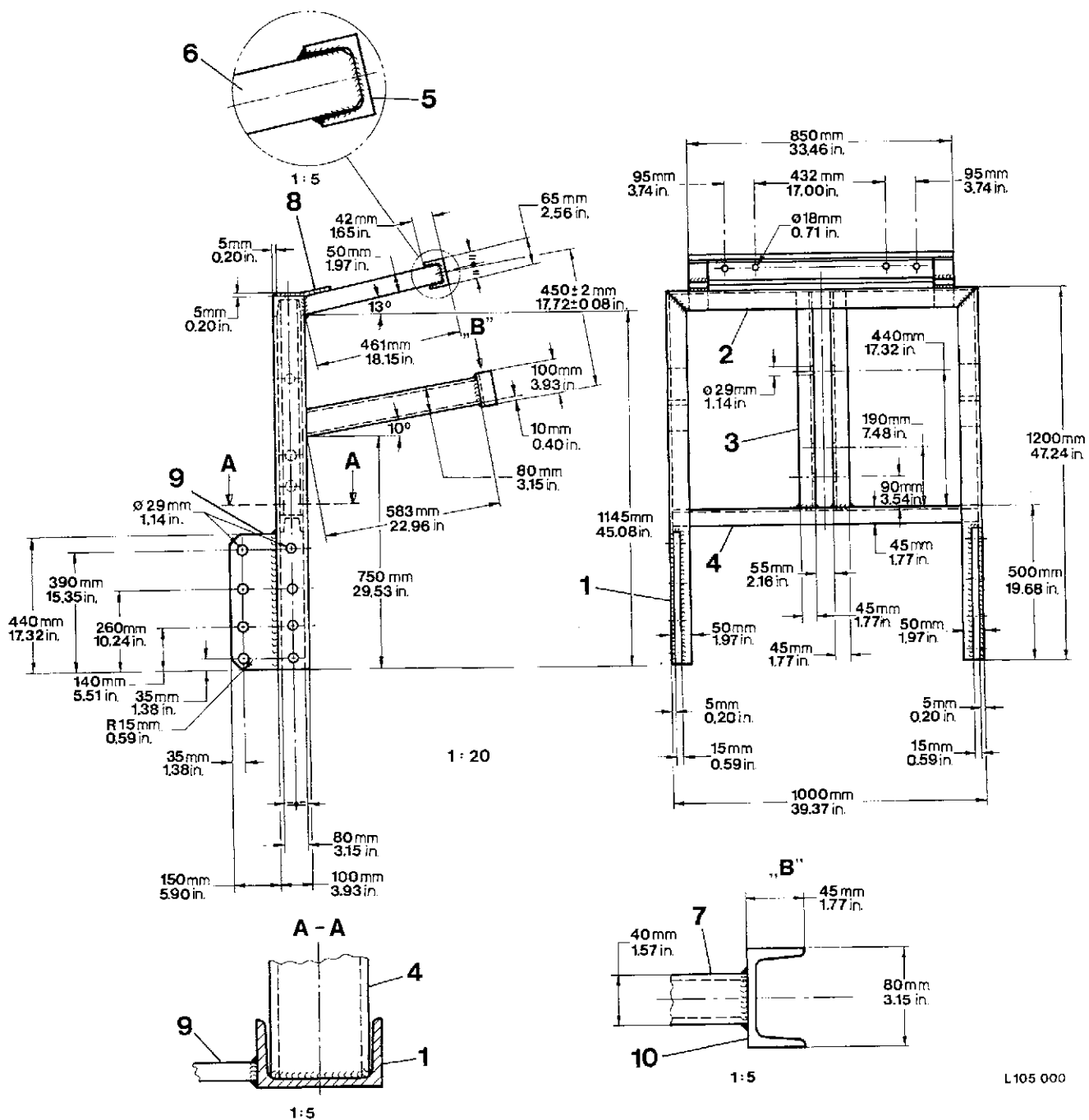
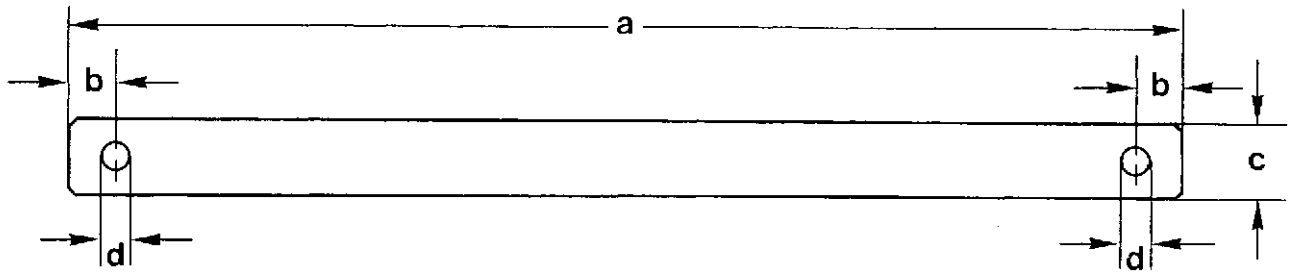

Fig. 7 – Lifting Device (Self-Manufacture), Removal of SG2 Cab (Quality Grade ST 37)

- 1 U-profile steel 100 x 1200 mm (3.94 x 47.24 in.) (2 used)
- 2 U-profile steel 100 x 1000 mm (3.94 x 39.37 in.) (1 used)
- 3 U-profile steel 80 x 694 mm (3.15 x 27.32 in.) (1 used)
- 4 U-profile steel 80 x 988 mm (3.15 x 38.9 in.) (1 used)
- 5 U-profile steel 65 x 850 mm (2.56 x 33.46 in.) (1 used)
- 6 Square steel 50 x 50 x 461 mm (1.97 x 1.97 x 18.15 in.) (2 used)
- 7 Square tubular steel 80 x 40 x 5 x 583 mm (3.15 x 1.58 x 0.2 x 22.95 in.) (2 used)
- 8 Flat steel 50 x 5 x 190 mm (1.97 x 0.2 x 7.48 in.) (2 used)
- 9 Flat steel 150 x 15 x 440 mm (5.9 x 0.59 x 17.32 in.) (2 used)
- 10 U-profile steel 80 x 100 mm (3.15 x 3.94 in.) (2 used)

Tractor Separation (Contd.)

L105 887

Fig. 8 — Steel Shaft (Self-Manufacture) for SG2 Cab Lifting Device

a 1100 mm (43.31 in.)
b 25 mm (0.98 in.)

c Diameter 22 mm (0.87 in.) with Cat. I draft links
29 mm (1.14 in.) with Cat. II draft links
d Diameter 5 mm (0.2 in.)

Group 05

Predelivery, Delivery and After-Sales Inspections

The John Deere Delivery Receipt, when properly filled out and signed by the dealer and customer, verifies that the predelivery and delivery services were satisfactorily performed. When delivering this machine, give the customer his copy of the delivery receipt and the operator's manual. Explain their purpose to him.

To promote complete customer satisfaction, a predelivery inspection including mending of possible shipping damage and giving the finishing touches to the tractor, is of prime importance to the dealer.

After the first 100 operating hours another inspection should be performed by the dealer to make sure that the tractor is in proper operating condition.

The predelivery and after-sale inspection check lists in the operator's manual will be completed by the dealer when the inspections are being performed. He will then forward them to the sales branch service department.

Tractor Storage

When storing a new tractor, proceed as follows:

Short Term (Under 30 Days)

1. Fill fuel tank. This prevents condensation of moisture in tank.
2. Check engine oil level, transmission-hydraulic oil level, and coolant level. Add oil or coolant if necessary. During cold weather, be sure coolant contains sufficient anti-freeze.

3. Check electrolyte level in batteries. If electrolyte does not cover plates, add distilled water. Make sure batteries are fully charged.
4. Store tractor in a dry, protected place. If necessary to store tractor outside, cover it with a protective material. Protect tires from heat, sunlight, and petroleum products.

Long Term (Over 30 Days)

To protect engine, fuel system, transmission and hydraulic system, use the AR 41785 rust inhibitor. The above part no. includes one can of rust inhibitor, masking tape and protective caps to cover all engine openings.

Protect the engine as follows:

1. Add 255 cm³ (9 oz.) of rust inhibitor to the engine oil.
2. Add 205 cm³ (7 oz.) of rust inhibitor to the oil in the transmission/hydraulic system on tractors with collar shift transmission and 250 cm³ (8.5 oz.) on tractors with synchronized transmission.
3. Drain fuel tank, pour 170 cm³ (6 oz.) of rust inhibitor into the empty tank and add approx. 10 liters (2.6 U.S.gals.) of fuel. Start engine and operate it at fast idle for 15 to 20 minutes to distribute the mixture through the whole fuel system. While the engine is running, operate the complete hydraulic system several times. Shut off engine in time to leave some fuel in the tank. Then allow the engine to cool down for 15 to 20 minutes.
4. Prepare 15 cm³ (0.5 oz.) of rust inhibitor for each cylinder. Remove plug of intake manifold or connecting pipe of starting fluid adapter at

the intake manifold, whichever applies, Inject rust inhibitor into the intake manifold. Pull out shut-off knob and crank engine with starter several times.

However, do not allow the engine to start. Otherwise the whole procedure must be repeated.

After the rust inhibitor has been added, the engine may not be started again.

IMPORTANT! Rust inhibitor agents evaporate very easily. For this reason, seal all openings after the inhibitor has been added. Also, always keep the inhibitor container closed.

5. Fill the fuel tank.
6. Remove batteries. Add distilled water, if necessary. Charge the batteries and store in a cool, dry place where they will not freeze.
7. Seal all openings such as the vent tube and exhaust outlet.
8. Slacken fan belt and air conditioning compressor belt (if equipped).
9. Replace or repair damaged parts. Touch up any painted surfaces which are scratched or chipped.
10. Coat exposed metal surfaces, such as axles and piston rods of hydraulic cylinders, with grease or corrosion preventative.
11. Store the tractor in a dry, protected place. If the tractor is stored outside, cover it with a waterproof tarpaulin.
12. Block up the tractor so that tires do not touch the ground. Protect tires from heat and sunlight.

Removing the Tractor from Storage

1. Remove all protective coverings.
2. Check crankcase and transmission/hydraulic system oil levels.
3. Check coolant level.
4. Check tire inflation pressure.
5. Install batteries and connect cable and ground strap.
6. Adjust fan belt and compressor belt (if equipped) tension.
7. Carry out 500-hour check.
8. Run engine at approx. 1500 rpm for some minutes. Check all systems before placing tractor under load.

Predelivery Inspection

Before delivering the tractor to the customer, the following checks and services should be performed by the dealer:

Engine

LEAKS

1. Check engine and fuel lines for leaks. Repair as necessary.

CHECKING CRANKCASE OIL LEVEL

NOTE: Tractor should be on a level surface when oil level is checked. If it is not, check only to make sure the crankcase is not dry. Recheck oil level later, when tractor is on level ground.

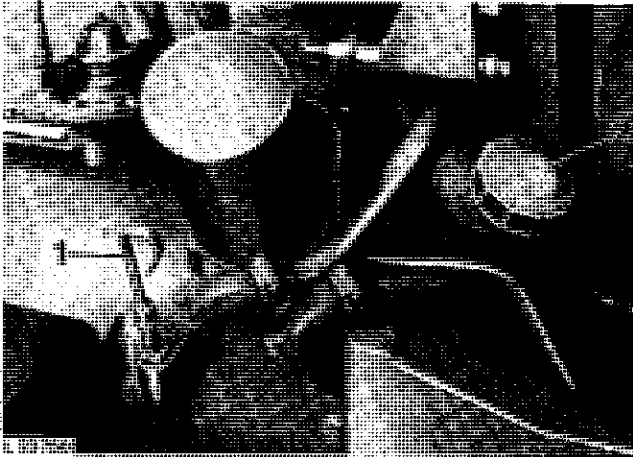

Fig. 1 — Engine Oil Dipstick and Filler Cap

- 1 Dipstick
- 2 Filler cap

1. Pull out dipstick 1 (fig. 1) and check oil level.
2. If necessary, add oil to bring oil level to top mark on dipstick. Use John Deere Torq-Gard Supreme engine oil SAE 10W-20 or an equivalent oil (see group 10).

CHECKING COOLANT LEVEL

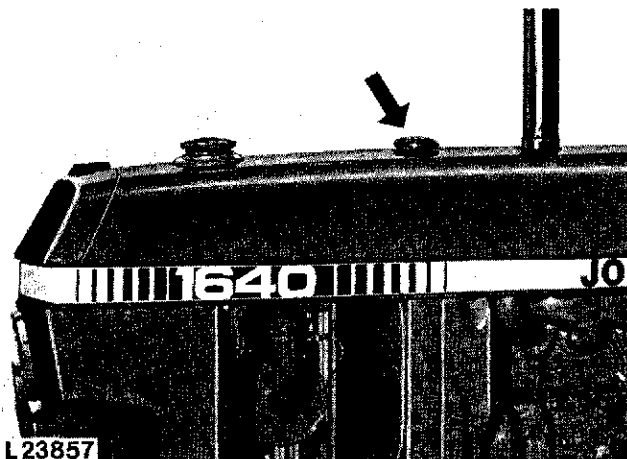

Fig. 2 — Radiator Filler Cap

1. Remove radiator filler cap and check coolant level. Coolant level must be midway between the filler neck and top of radiator core.

2. If necessary, add coolant to obtain this level.

John Deere Engine Cooling Fluid is filled into the cooling system at the factory. It protects the engine against corrosion and against frost down to -36°C (-35°F).

IMPORTANT: Use only John Deere Engine Cooling Fluid in the cooling system, independent of the season.

If no John Deere Engine Cooling Fluid is available use a mixture of 50 % ethylene-glycol antifreeze/ anticorrosion inhibitor and 50 % clear, soft water. This mixture guarantees engine protection against corrosion and against frost down to -36°C (-35°F).

Never use any cooling system sealing additives.

IDLE SPEEDS

1. Check slow and fast idle speeds and adjust if necessary.
2. Slow idle speed: 700 to 800 rpm
3. Fast idle speed: 2610 to 2660 rpm
4. Warm up engine to operating temperature and check slow and fast idle speeds Adjust, if necessary (see Section 30, Group 20).

ENGINE SHUT-OFF CABLE

1. Check operation of shut-off cable. Move hand throttle lever completely forward and idle engine for 1 to 2 minutes.
2. Completely pull out shut-off knob, making sure engine stops immediately.
3. If necessary, adjust shut-off cable (see Section 30, Group 20).

AIR CLEANER AND SAFETY ELEMENT

Fig. 3 — Air Cleaner and Safety Element

- | | |
|-----------------------|------------------------|
| 1 Safety element | 4 Wing nut |
| 2 Air cleaner element | 5 Dust unloading valve |
| 3 Cover | |

1. Check air cleaner and safety elements for proper installation.
2. Make sure that dust unloading valve 5 (fig. 3) (rubber cap) is installed on air cleaner.

AIR INTAKE CONNECTIONS

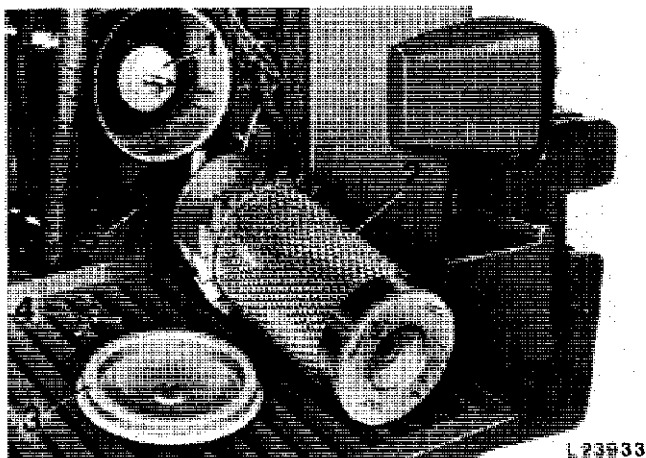
1. Check air intake connections for tightness. Tighten any loose clamps.

EXHAUST STACK

1. Install exhaust stack, making sure it is in vertical position.
2. Install exhaust stack flap with flap hinge at the rear (as seen in direction of forward travel). When closed, flap should not contact exhaust stack end. If necessary, clamp flap to exhaust stack to obtain a clearance of 2 mm (0.08 in.) between flap and stack end.

CHECKING V-BELT TENSION**Fan Belt**

1. The fan belt should have 19 mm (3/4 in.) flex with 90 N (20 lb) pull midway between crankshaft and alternator or water pump (use a spring scale).

Compressor Belt (if equipped)

1. Compressor belt should deflect 19 mm (3/4 in.) when a 60 N (13 lb) force is applied midway between pulleys.

Electrical System**BATTERIES**

1. Check battery terminals and battery cable ends. If they are corroded, clean and coat them with petroleum jelly.
2. Check electrolyte level in each battery cell. Add distilled water if necessary to bring level above cell plates.
3. If batteries are not fully charged, charge them. Remove cell caps before charging the battery.

Important Notes

1. If the engine is to be run for a short time without battery (using a slave battery for starting), do not, under any circumstances, interrupt the circuit by switching off the main switch before stopping the engine by means of the fuel pump shut-off cable. Further it is recommended to use additional current (lights) while engine is running. Do not run engine at a speed above 1000 rpm. Insulate battery end of disconnected starter cable properly to avoid damage to alternator and regulator.

On tractors with operator's cab: Do not connect ground strap of slave battery to cab.

2. Connect batteries or battery charger in the proper polarity ("+" and "-"). If they are improperly connected, the rectifier diodes will be immediately destroyed.

START SAFETY SWITCH

1. Move range shift lever into neutral or "park"* position.
2. Check function of start safety switch. Replace switch when necessary (see Section 40, Group 15).

LIGHTING SYSTEM

1. Check lighting system and repair as necessary. Replace any defective bulbs (see Section 40, Group 20).
2. Check headlight adjustment and correct, if necessary (see Section 40, Group 20).

OPERATOR'S CAB CONTROLS

Fan Switch

1. Open air outlets. Check fan switch 2 (fig. 4 or 5) for proper operation.

* On tractors with collar shift transmission and parking lock only

Heater Switch

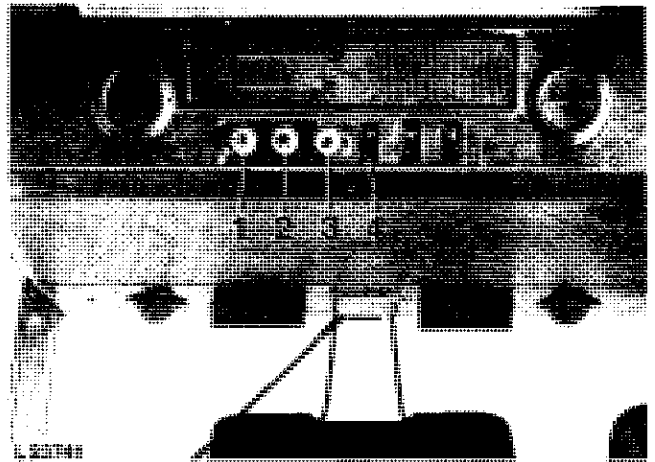

Fig. 4 — Operator's Cab Controls (OPU Cab)

- | | |
|-----------------|---|
| 1 Heater switch | 3 Thermostat switch
(air conditioning) |
| 2 Fan switch | 4 Windshield wiper switch |

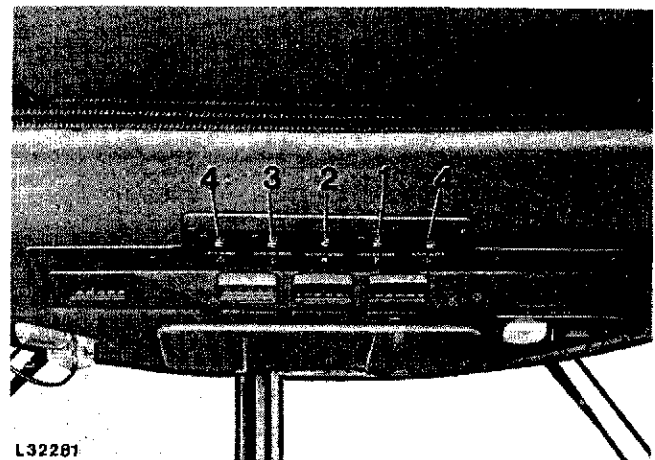

Fig. 5 — Operator's Cab Controls (SG2 Cab)

- | | |
|-----------------|---|
| 1 Heater switch | 3 Thermostat switch
(air conditioning) |
| 2 Fan switch | 4 Windshield wiper switch |

With fan operating, check heater switch 1 (fig. 4 or 5) for proper operation. For this purpose, turn switch on tractors equipped with OPU cab to the left and with SG2 cab to the right, making sure that warm air enters cab (with engine at operating temperature).

Thermostat Switch (Tractors with Air Conditioning)

With fan operating, check infinitely variable thermostat switch (if equipped) for proper operation. Turn off heater. Turn thermostat switch 3 (fig. 4) clockwise, making sure cool air enters cab. If switch does not operate correctly, see Section 90, Group 05.

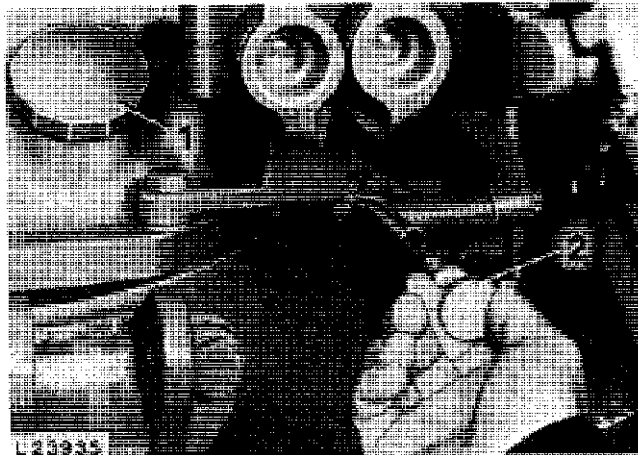

Fig. 6 – Transmission/Hydraulic System Dipstick and Filler Cap (Tractor with Synchronized Transmission)

- 1 Filler cap
- 2 Dipstick

Windshield Wiper Switch

Check windshield wiper switch for proper operation.

CONTROLS AND INSTRUMENTS

Check controls and instruments for proper operation.

NOTE: On tractors with collar shift transmission, transmission oil pressure indicator light glows only when a malfunction occurs.

Power Train

CHECKING TRANSMISSION/HYDRAULIC SYSTEM OIL LEVEL

1. With the tractor on level ground, run the engine 2 to 3 minutes.
2. Place range and gear shift lever in neutral position.
3. Apply handbrake.
4. Lower draft links.
5. Run engine at slow idle (700 to 800 rpm).

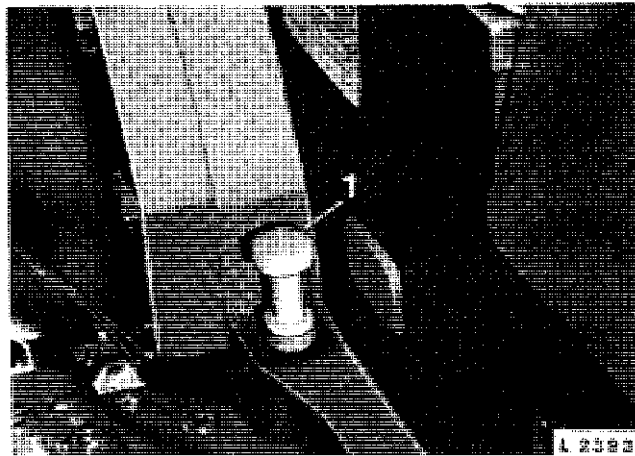

Fig. 7 – Transmission/Hydraulic System Dipstick (Tractor with Collar Shift Transmission)

- 1 Dipstick

6. Pull out dipstick and wipe clean.
7. Insert dipstick. Remove dipstick and check oil level.

8. If necessary, add John Deere Hy-Gard Transmission and Hydraulic Oil or equivalent oil to bring oil level to top mark on dipstick.

NOTE: Types of oil not meeting our specifications will not give satisfactory service and may result in eventual damage.

TRANSMISSION

1. Check transmission for proper operation.
2. While driving tractor, shift transmission through all gears. If transmission does not function properly, refer to Section 50, Groups 30 and 35 or 40.

DIFFERENTIAL LOCK

Check differential lock for proper operation. If you find any problem, refer to Section 50, Group 45.

PTO

Check PTO operation. For this purpose, run engine and move PTO control lever to engaged and disengaged position. If PTO does not operate properly, refer to Section 50, Group 55 or 60.

HI-LO SHIFT UNIT

Check Hi-Lo shift unit as follows:

1. Operate tractor in both high and low ranges, carefully observing both operations.
2. Use the brakes to simulate a load condition on the tractor.

3. Low oil pressure will be indicated by disk pack slippage, which causes the clutch pack to become noisy.
4. A mechanical failure in the Hi-Lo shift unit will also be indicated by unusual noise.
5. If you find any problems, refer to Section 50, Group 20.

CREEPER TRANSMISSION

Check function of creeper transmission as follows:

1. Drive the tractor, disengage the clutch, engage creeper transmission and engage gears of range I and Reverse.
2. Refer to Section 50, Group 25 should a malfunction occur.

CLUTCH PEDAL

Tractors without Operator's Cab or with OPU Cab

1. Check clutch pedal free travel. It should be approx. 25 mm (1 in.).
2. Make sure that clutch is fully disengaged before pedal contacts stop bracket. Adjust clutch pedal free travel, if necessary (see Section 50, Group 10).

Tractors with SG2 Cab

1. Depress clutch pedal until it contacts stop. When doing this the operating rod should move 8.5 to 12.0 mm (5/16 to 15/32 in.) out of clutch operating cylinder.
2. When necessary, bleed clutch operating system (see Section 50, Group 10).

MECHANICAL FRONT WHEEL DRIVE**Checking Axle Housing Oil Level**

1. Remove level plug 1 (fig. 8 or 9). Oil should be level with plug bore.
2. If necessary, top up with oil, using oil as specified in group 10 of this section.

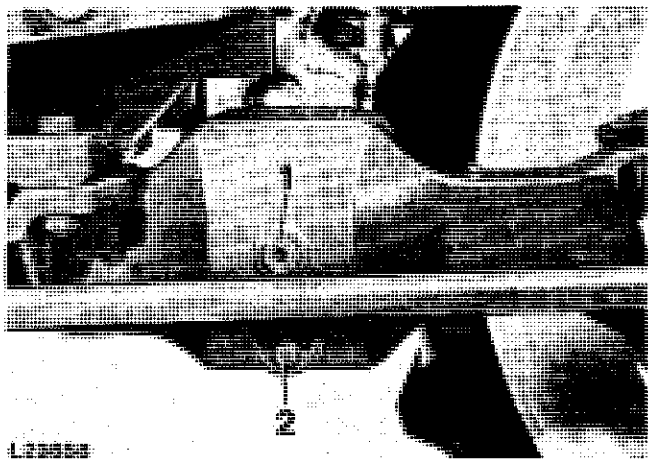

Fig. 8 – Checking Axle Housing Oil Level

- 1 Level plug
- 2 Drain plug

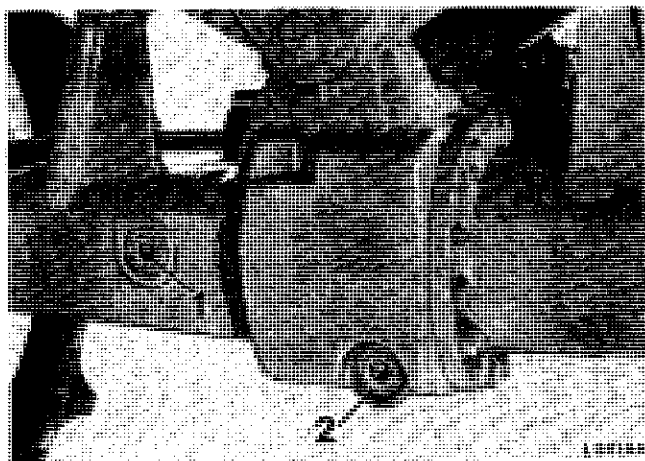
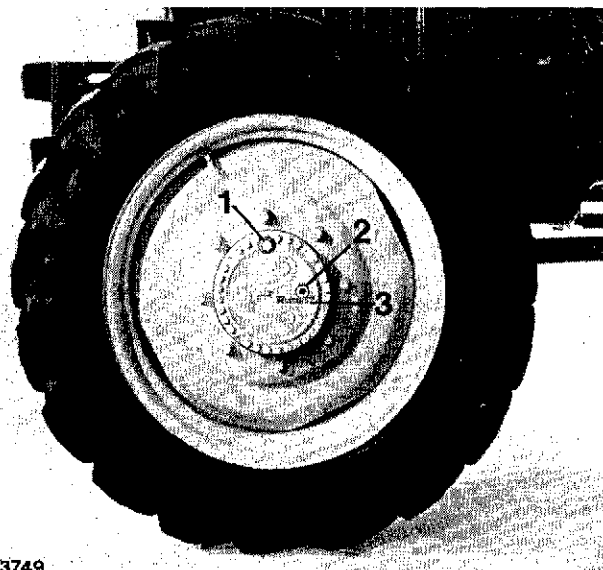

Fig. 9 – Checking Axle Housing Oil Level (from serial no. 450 000 L)

- 1 Level plug
- 2 Drain plug

Checking Final Drives Oil Level

1. Turn wheel until mark 3 or 2 "Ölstand" (fig. 10 or 11) is in level position.
2. Remove level plug 2 or 1. Oil should be level with plug bore.
3. Add oil, if necessary, using oil as specified in group 10 of this section.



L23749

Fig. 10 – Checking Final Drives Oil Level (up to serial no. 449 999 L)

- 1 Drain plug
- 2 Level plug
- 3 Oil level mark

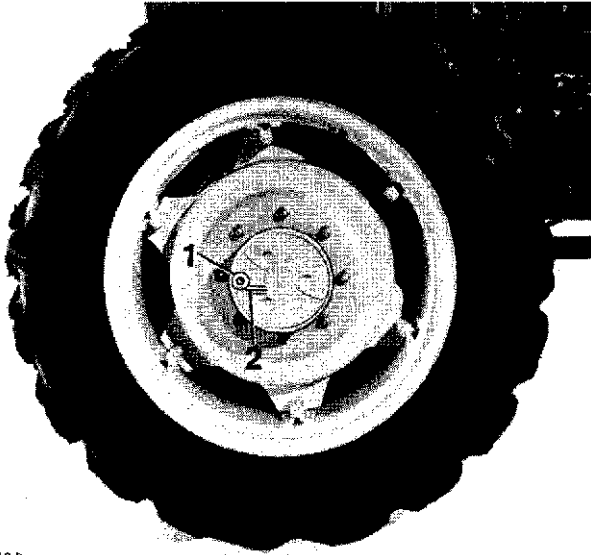

L 95198

Fig. 11 — Checking Final Drives Oil Level (from serial no. 450 000 L)

- 1 Level plug
- 2 Oil level mark

FWD Operation

1. Check FWD for proper operation. If you find any problems, refer to Section 50, Group 65.

Steering and Brakes

STEERING

1. Check steering system for proper operation. In case of a malfunction, refer to Section 60, Group 05, 10 or 15.

BRAKES

1. Check footbrakes and handbrake for proper operation. Adjust brakes, if necessary. Refer to Section 60, Group 20 if a malfunction occurs.

Hydraulic System

LEAKS

1. Check entire hydraulic system for leaks. Repair components when necessary.

ROCKSHAFT

1. Check rockshaft operation. In case of a malfunction, refer to Section 70, Group 20.

SELECTIVE CONTROL VALVES

1. Check operation of selective control valves. In case of a malfunction, refer to Section 70, Group 25 or 30.

THREE-POINT HITCH

Install and/or adjust draft links and center link (see operator's manual).

WHEEL BOLTS

1. Tighten all wheel bolts to the specified torque. See Section 80, Group 15.

TIRE PRESSURES

1. Check tire pressures (see operator's manual).

TREAD WIDTH

1. Adjust tread width to customer's needs (see operator's manual).

TOE-IN

1. Check toe-in and adjust, if necessary (see Section 80, Group 05).

LUBRICATING POINTS

1. Lubricate all lubricating points on tractor as described in group 10 of this section, using John Deere EP multi-purpose grease or SAE EP multi-purpose grease.

ROLL GUARD

1. Check roll guard for proper installation.
2. Tighten cap screws to specified torque (see Section 90, Group 30).

GUARDS

1. Check all guards for proper installation.

DECALS AND PAINT

1. Check decals and paint for proper condition.

Operator's Cab**AIR CONDITIONING SYSTEM**

1. Check operation of air conditioning system. If you find any problems, refer to Section 90, Group 05.
2. Check refrigerant lines for leaks. Repair or replace parts as necessary.

OPERATOR'S SEAT

1. Check whether operator's seat can be adjusted properly.
2. Check seat belts for proper condition and correct installation.

OPERATOR'S CAB

1. Check operator's cab for proper installation.
2. Tighten attaching cap screws or hex. nuts to specified torque, see Section 90, Group 20 or 25.

Delivery Inspection

A thorough discussion of the operation and service of the tractor at the time of its delivery helps to assure complete customer satisfaction.

Proper delivery should be an important part of the dealer's program.

It is a well-known fact that many complaints have arisen simply because the owner was not shown how to operate and service his new tractor properly. Therefore, enough time should be devoted, at the customer's convenience, to introducing him to his new tractor and explaining to him how to operate and service it.

Using the tractor operator's manual as a guide, be sure that the owner understands the following points properly:

1. Operation of control levers and instruments
2. Starting and shutting off the engine
3. The importance of the tractor break-in period
4. Use of counterweights and proper tire inflation pressure as well as filling of tires with water and calcium chloride, if required
5. All functions of the hydraulic system
6. Operating the PTO and belt pulley (if equipped)
7. The importance of the safety rules
8. The importance of lubrication and periodic service

Give particular emphasis to sway blocks, rockshaft speed-of-drop, rockshaft selector lever (load and depth control), transmission oil pressure indicator light, engine oil pressure indicator light (whether temperature or pressure and what to do if lights go on), alternator indicator light (indicating whether alternator is charging) and operator's cab air filters. These areas are very often misunderstood.

After-Sales Inspection

In the interest of the purchaser and the dealer an after-sales inspection should be carried out by the dealer after the first 100 hours of using a new John Deere tractor.

The purpose of this inspection is to make sure that the customer is receiving satisfactory performance from his tractor. At the same time, the inspection should reveal whether or not the tractor is being operated, lubricated and serviced properly.

Through this inspection a needless volume of service work can be eliminated by preventing minor difficulties from developing into serious problems later on. It also will promote stronger dealer-customer relations and give the customer an opportunity to ask questions that may have arisen during the first few days of use.

Thereby the dealer has the further opportunity of promoting the possible sale of other new equipment.

The following inspection program is recommended:

Engine

LEAKS

Check engine and fuel lines for leaks. Repair as necessary.

OIL AND FILTER CHANGE

NOTE: Drain oil with engine shut off, however with engine oil warm.

1. Remove drain plug.
2. While oil is draining, replace filter element.
3. Remove filter element (turn counterclockwise) and clean mounting surface.

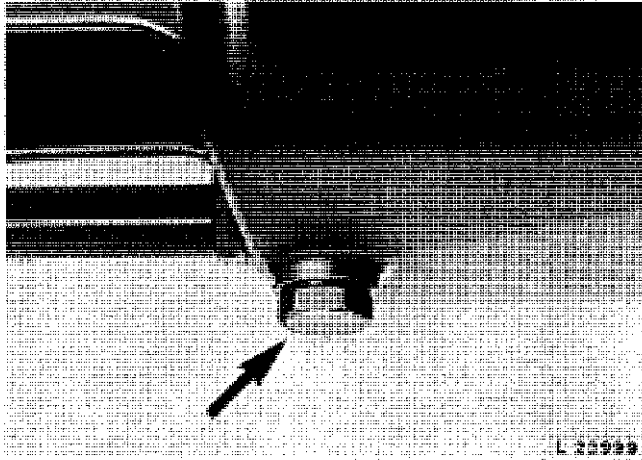

Fig. 12 – Crankcase Drain Plug

4. Apply a thin film of oil to sealing ring of new filter. Tighten filter element until sealing ring touches mounting surface, then turn an additional 1/2 to 3/4 turns. Do not overtighten.
5. Reinstall drain plug.
6. Fill crankcase with fresh oil of the proper viscosity (see group 10).

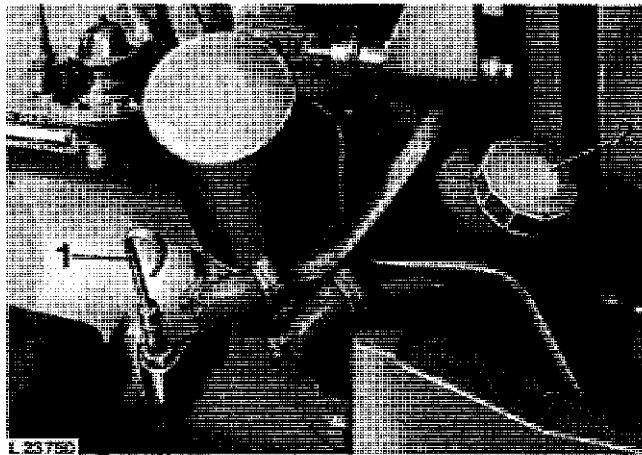

Fig. 13 – Engine Oil Dipstick and Filler Cap

- 1 Dipstick
- 2 Filler cap

7. Crankcase capacity with filter change: 8,5 liters (2.25 U.S.gal.).
8. Run engine for a short time and check for leaks at filter base and drain plug.
9. Stop engine.
10. Check oil level.

CHECKING VALVE CLEARANCE

1. Using a feeler gauge, check valve clearance. If necessary, adjust clearance (see Technical Manual – Engines).

Valve clearance (with the engine cold or warm)
 Intake valve0.35 mm (0.014 in.)
 Exhaust valve0.45 mm (0.018 in.)

CHECKING COOLANT LEVEL

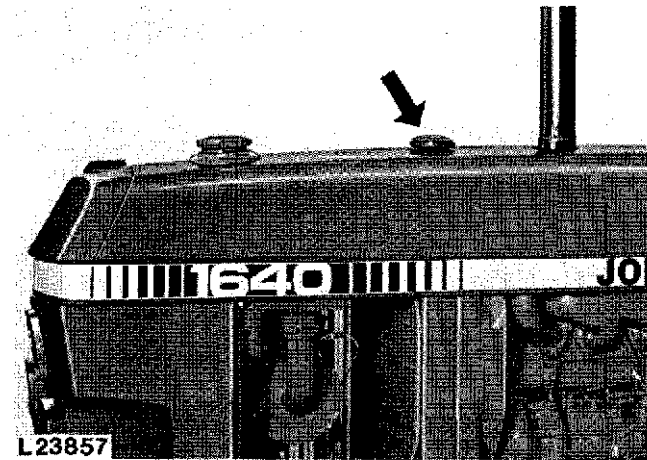

Fig. 14 – Radiator Filler Cap

1. Remove radiator filler cap and check coolant level. Coolant level must be midway between the filler neck and top of radiator core.
2. If necessary, add coolant to obtain this level (see page 3).

IDLE SPEEDS

1. Check slow and fast idle speeds and adjust if necessary.
2. Slow idle speed: 700 to 800 rpm.
3. Fast idle speed: 2610 to 2660 rpm.
4. Warm up engine to operating temperature and check slow and fast idle speeds. Adjust, if necessary (see Section 30, Group 20).

HAND THROTTLE LEVER

Check whether hand throttle lever can be moved properly. Adjust, if necessary.

ENGINE SHUT-OFF CABLE

1. Check operation of shut-off cable. Move hand throttle lever completely forward and idle engine for 1 to 2 minutes.
2. Completely pull out shut-off knob, making sure engine stops immediately.
3. If necessary, adjust shut-off cable (see Section 30, Group 20).

AIR CLEANER AND SAFETY ELEMENT

Fig. 15 — Air Cleaner and Safety Element

- 1 Safety element
- 2 Air cleaner element
- 3 Cover
- 4 Wing nut
- 5 Dust unloading valve

1. Check air cleaner and safety elements for proper installation.
2. Make sure that dust unloading valve 5 (fig. 15) (rubber cap) is installed on air cleaner.

AIR INTAKE CONNECTIONS

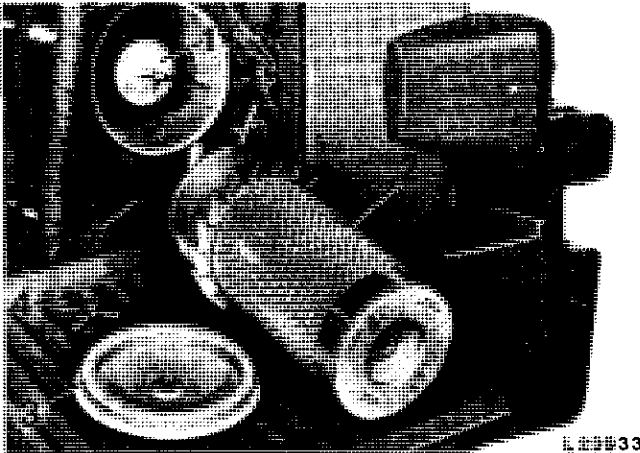
Check air intake connections for tightness. Tighten any loose clamps.

CHECKING V-BELT TENSION**Fan Belt**

The fan belt should have 19 mm (3/4 in.) flex with 90 N (20 lb) pull midway between crankshaft and alternator or water pump (use a spring scale).

Compressor Belt (if equipped)

Compressor belt should deflect 19 mm (3/4 in.) when a 60 N (13 lb) force is applied midway between pulleys.

Electrical System**BATTERIES**

1. Check battery terminals and battery cable ends. If they are corroded, clean and coat them with petroleum jelly.
2. Check specific gravity of battery cells. At an electrolyte temperature of 20°C (68°F), a fully charged battery should have a specific gravity of 1.28 under normal and arctic conditions and 1.23 in tropical areas.
3. Check electrolyte level in each battery cell. Add distilled water if necessary to bring level above cell plates.
4. If batteries are not fully charged, charge them. Remove cell caps before charging the battery.

Important Notes

1. If the engine is to be run for a short time without battery (using a slave battery for starting), do not, under any circumstances, interrupt the circuit by switching off the main switch before stopping the engine by means of the fuel pump shut-off cable. Further it is recommended to use additional current (lights) while engine is running. Do not run engine at a speed above 1000 rpm. Insulate battery end of disconnected starter cable properly to avoid damage to alternator and regulator.

On tractors with operator's cab: Do not connect ground strap of slave battery to cab.

2. Connect batteries or battery charger in the proper polarity ("+" and "-"). If they are improperly connected, the rectifier diodes will be immediately destroyed.

START SAFETY SWITCH

1. Move range shift lever into neutral or "park" position.
2. Check operation of start safety switch. If the starting switch does not work see Section 40, Group 15.

LIGHTING SYSTEM

1. Check lighting system and repair if necessary. Replace any defective bulbs (see Section 40, Group 20).
2. Check headlight adjustment and correct, if necessary (see Section 40, Group 20).

OPERATOR'S CAB CONTROLS**Fan Switch**

1. Open air outlets. Check fan switch 2 (fig. 16 or 17) for proper operation.

Heater Switch

1. With fan operating, check heater switch 1 (fig. 16 or 17) for proper operation. For this purpose, turn switch on tractors equipped with OPU cab to the left and with SG2 cab to the right. Making sure that warm air enters cab (with engine at operating temperature).

If this is not the case, replace heater switch. If necessary, check coolant flow through heater core (see Section 90, Group 10).

Thermostat Switch (Tractors with Air Conditioning)

1. With fan operating, check infinitely variable thermostat switch (if equipped) for proper operation. Turn off heater. Turn thermostat switch 3 (fig. 16 or 17) clockwise, making sure cool air enters cab. If switch does not operate correctly, see Section 90, Group 05.

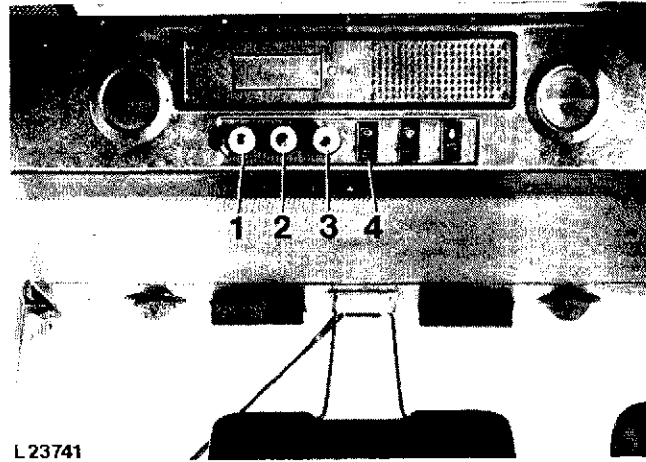

L23741

Fig. 16 – Operator's Cab Controls (OPU Cab)

1 Heater switch
2 Fan switch

3 Thermostat switch
(air conditioning)
4 Windshield wiper switch

* On tractors equipped with collar shift transmission and parking lock only.

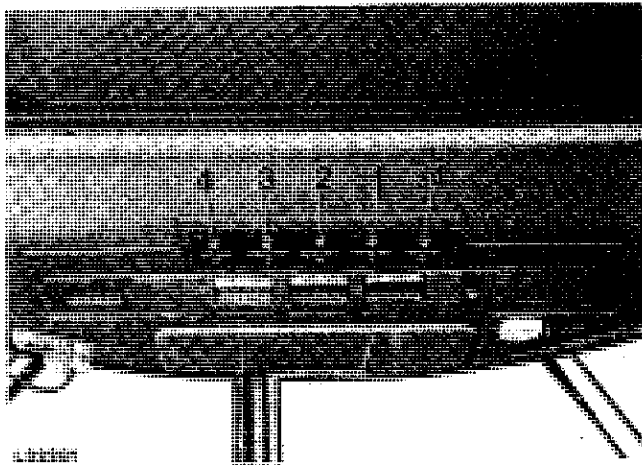

Fig. 17 — Operator's Cab Controls (SG2 Cab)

- | | |
|-----------------|---|
| 1 Heater switch | 3 Thermostat switch
(air conditioning) |
| 2 Fan switch | 4 Windshield wiper switch |

Windshield Wiper Switch

Check windshield wiper switch for proper operation.

CONTROLS AND INSTRUMENTS

Check controls and instruments for proper operation.

NOTE: On tractors with collar shift transmission, transmission oil pressure indicator light glows only when a malfunction occurs.

Power Train

CHECKING TRANSMISSION/HYDRAULIC SYSTEM OIL LEVEL

1. With the tractor on level ground, run the engine 2 to 3 minutes.

2. Place range and gear shift lever in neutral position.
3. Apply handbrake.
4. Lower draft links.
5. Run engine at slow idle (700 to 800 rpm).

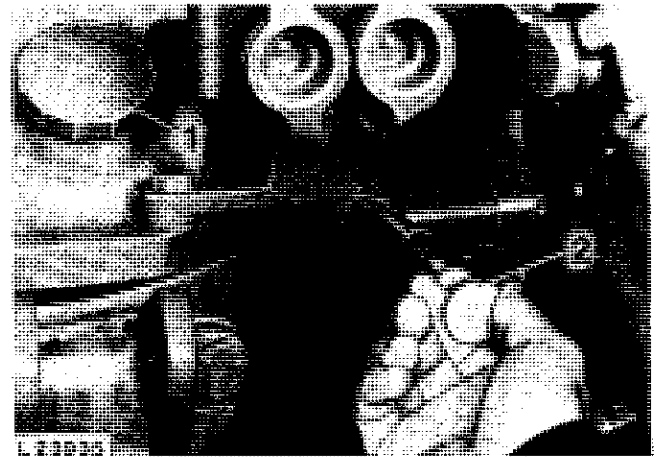

Fig. 18 — Transmission/Hydraulic System Dipstick and Filler Cap (Tractor with Synchronized Transmission)

- 1 Filler cap
- 2 Dipstick

6. Pull out dipstick and wipe clean.
7. Insert dipstick. Remove dipstick and check oil level.
8. If necessary, add John Deere Hy-Gard Transmission and Hydraulic Oil or equivalent oil (see Group 10) to bring oil level to top mark on dipstick.

NOTE: Types of oil not meeting our specifications will not give satisfactory service and may result in eventual damage.

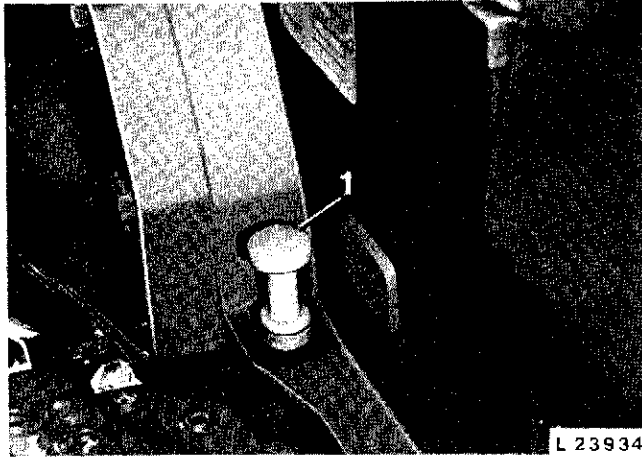

Fig. 19 – Transmission/Hydraulic System Dipstick
(Tractor with Collar Shift Transmission)

1 Dipstick

TRANSMISSION

1. Check transmission for proper operation.
2. While driving tractor, shift transmission through all gears. If transmission does not function properly, refer to Section 50, Group 30 and 35 or 40.

DIFFERENTIAL LOCK

Check differential lock for proper operation. If you find any problem, refer to Section 50, Group 45.

PTO

Check PTO operation. For this purpose, run engine and move PTO control lever to engaged and disengaged position. If PTO does not operate properly, refer to Section 50, Group 55 or 60.

HI-LO SHIFT UNIT

Check Hi-Lo shift unit as follows:

1. Operate tractor in both high and low range, carefully observing both operations.
2. Use the brakes to simulate a load condition on the tractor.
3. Low oil pressure will be indicated by disk pack slippage, which causes the clutch pack to become noisy.
4. A mechanical failure in the Hi-Lo shift unit will also be indicated by unusual noise.
5. If you find any problems, refer to Section 50, Group 20.

CREEPER TRANSMISSION

Check function of creeper transmission as follows:

1. Drive the tractor, disengage the clutch, engage creeper transmission and engage gears of range I and Reverse.
2. Refer to Section 50, Group 25 should a malfunction occur.

CLUTCH PEDAL

Tractors without Operator's Cab or with OPU Cab

1. Check clutch pedal free travel. It should be approx. 25 mm (1 in.).
2. Make sure that clutch is fully disengaged before pedal contacts stop bracket. Adjust clutch pedal free travel, if necessary (see Section 50, Group 10).

Tractors with SG2 Cab

1. Depress clutch pedal until it contacts stop. When doing this the operating rod should move 8.5 to 9.5 mm (0.33 to 0.37 in.) out of clutch operating cylinder.
2. When necessary, bleed clutch operating system (see Section 50, Group 10).

MECHANICAL FRONT WHEEL DRIVE

NOTE: Drain oil immediately after having operated the tractor for some time when the oil is still warm.

Axle Housing Oil Change

1. Remove drain plug 2 (fig. 20 or 21) and drain oil.
2. Reinstall drain plug and tighten securely.

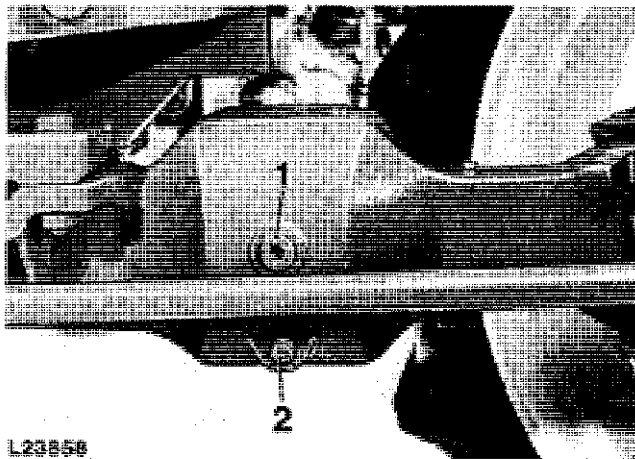

Fig. 20 — Axle Housing Oil Level

- 1 Level plug
- 2 Drain plug

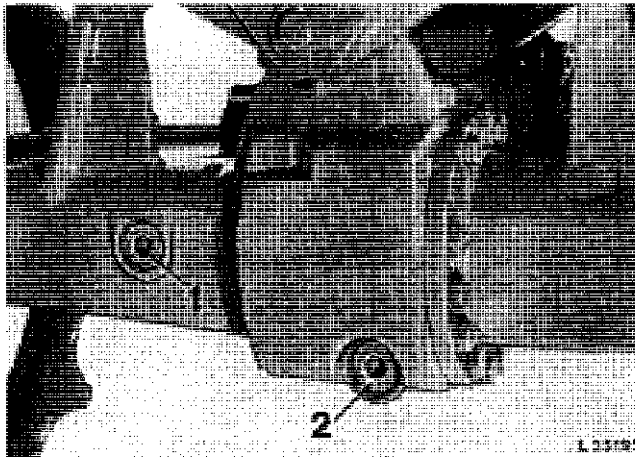

Fig. 21 — Axle Housing (from Serial No. 450 000 L)

- 1 Level plug
- 2 Drain plug

3. Remove level plug and fill with EP Transmission Oil (see Group 10). Oil should be level with bore of level plug.
4. Reinstall and tighten level plug.

Oil Capacity — Axle Housing

up to serial no. 449 999 L	5.3 liters
	(1.4 U.S.gal.)
from serial no. 450 000 L	5.0 liters
	(1.3 U.S.gal.)

Final Drives Oil Change

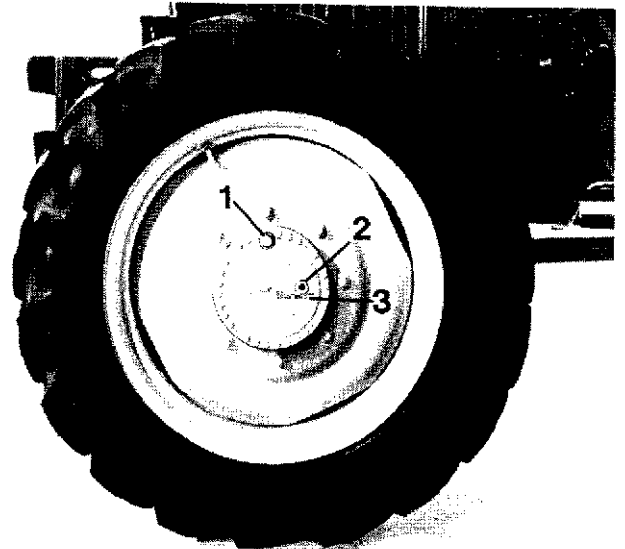

L23749

Fig. 20 — Final Drive Housing (up to Serial No. 449 999 L)

- 1 Drain plug
- 2 Level plug
- 3 Oil level mark

1. Turn wheel until drain plug 1 (fig. 22 or 23) is at the bottom. Remove drain plug and drain oil.
2. Turn wheel until mark "Ölstand" is in level position.

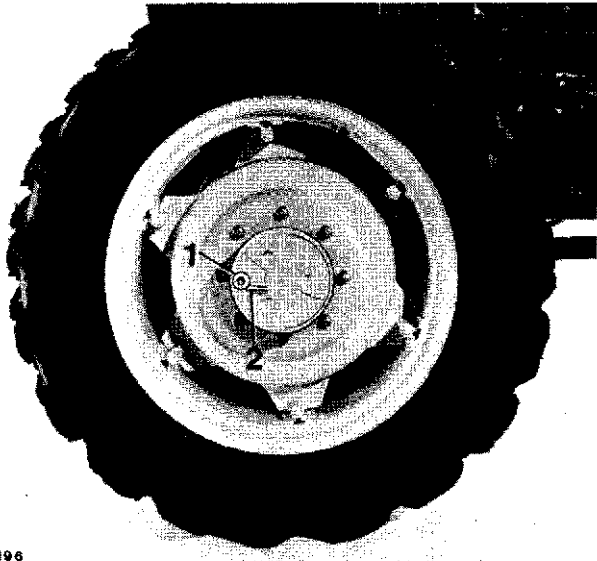

L 35196

Fig. 23 – Final Drive Housing (from Serial No. 450 000 L)

- 1 Drain plug
- 2 Oil level mark

3. *On tractors up to serial no. 449 999 L:* Remove level plug 2 (fig. 22).
4. Fill with fresh oil through hole of drain plug 1 (fig. 22 or 23). Use EP transmission oil according to specifications given in Group 10.

Oil Capacity – Each Final Drive Housing

up to serial no. 449 999 L	0.75 liter (0.2 U.S.gal.)
from serial no. 450 000 L	0.75 liter (0.2 U.S.gal.)

5. *On tractors up to serial no. 449 999 L:* Oil level should be up to level of level plug bore.

On tractors from serial no. 450 000 L: Oil level should be up to level of drain plug bore.

6. Reinstall and tighten oil level plug and drain plug.

MFWD Operation

1. Check MFWD for proper operation. If you find any problems, refer to Section 50, Group 65 .

Steering and Brakes

STEERING

1. Check steering system for proper operation. In case of a malfunction, refer to Section 60, Group 05, 10 or 15.

BRAKES

1. Check footbrakes and handbrake for proper operation. Adjust brakes, if necessary. Refer to Section 60, Group 20 if a malfunction occurs.

Hydraulic System

ROCKSHAFT

1. Check rockshaft operation. In case of a malfunction, refer to Section 70, Group 20.

SELECTIVE CONTROL VALVES

1. Check operation of selective control valves. In case of a malfunction, refer to Section 70, Group 25 or 30.

LEAKS

1. Check entire hydraulic system for leaks. Repair or replace components as necessary.

Miscellaneous

GUARDS

1. Check all guards for proper installation.

ROLL GUARD

1. Check roll guard for proper installation.
2. Tighten cap screws to specified torque (see Section 90, Group 30).

Operator's Cab

AIR CONDITIONING SYSTEM

1. Check operation of air conditioning system. If you find any problems, refer to Section 90, Group 05.
2. Check refrigerant lines for leaks. Repair or replace parts as necessary.

OPERATOR'S SEAT

1. Check whether operator's seat can be adjusted properly.
2. Check seat belts for proper condition and correct installation.

OPERATOR'S CAB

1. Check operator's cab for proper installation.
2. Tighten attaching cap screws or hex. nuts to specified torque, see Section 90, Group 20 or 25.

Group 10

Lubrication and Service

Effective use of lubricating oils and greases is perhaps the most important step toward low upkeep costs, long tractor life, and satisfactory service. Use only lubricants specified in this section.

NOTE: Depending on the lowest expected atmospheric temperature at start for the fill period, use oil of viscosity as shown in fig. 1.

Engine Lubricating Oil

John Deere TORQ-GARD SUPREME[®] engine oil or John Deere HD Engine Oil is recommended. If other oils are used, they must be premium engine oils meeting performance requirements of:

- API Service Classification CD/SC
- Military Specification MIL-L-2104C

For low temperature operation, where oils meeting the above requirements may not be available in appropriate viscosity grade, oils meeting the performance requirements of API Service Classification CC/SC or Military Specification MIL-L-46152 or MIL-L-46167 (Arctic Oil) may be used but at shorter drain intervals.

Quality engine oils are blended, so additives are neither required nor recommended.

NOTE: Some increase in oil consumption may be expected when SAE 5W-20 or Arctic Oils are used. Check oil level more frequently.

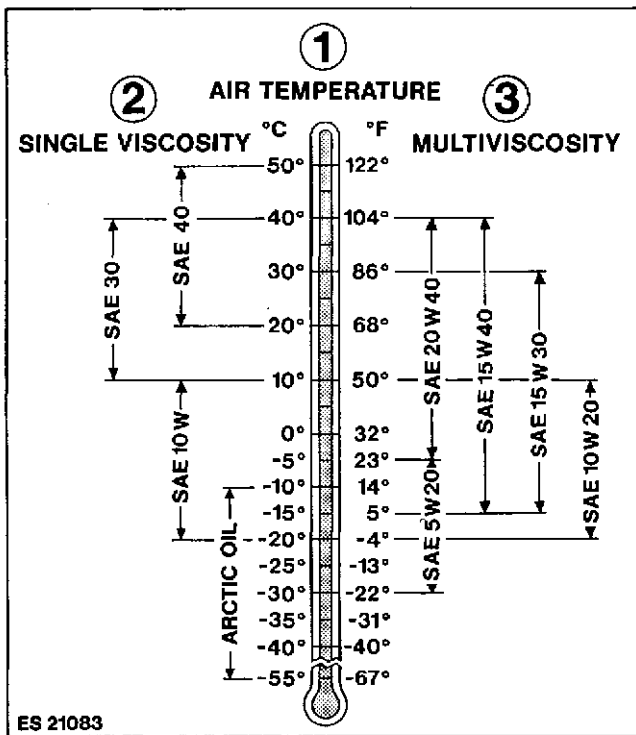

Fig. 1 - Oil Viscosity at Expected Temperature

Transmission-Hydraulic Oil

Oil for Mechanical Front Wheel Drive

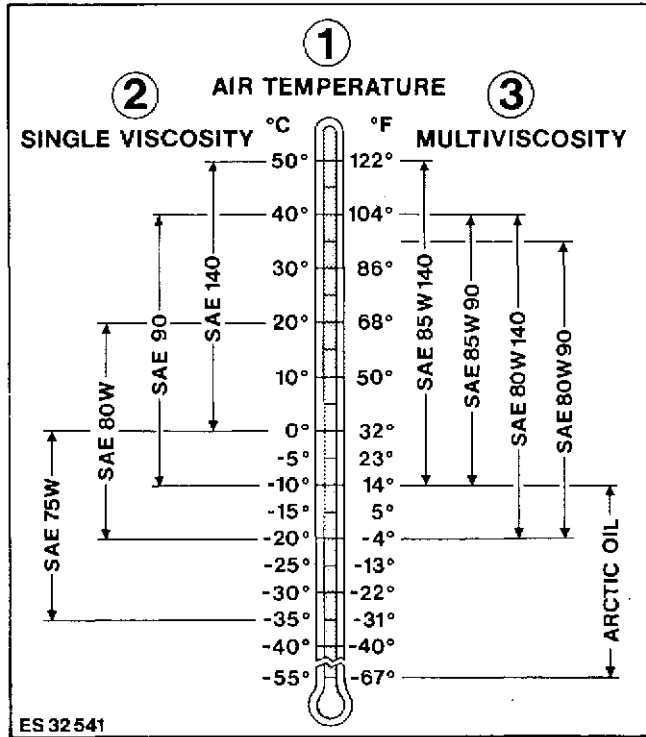
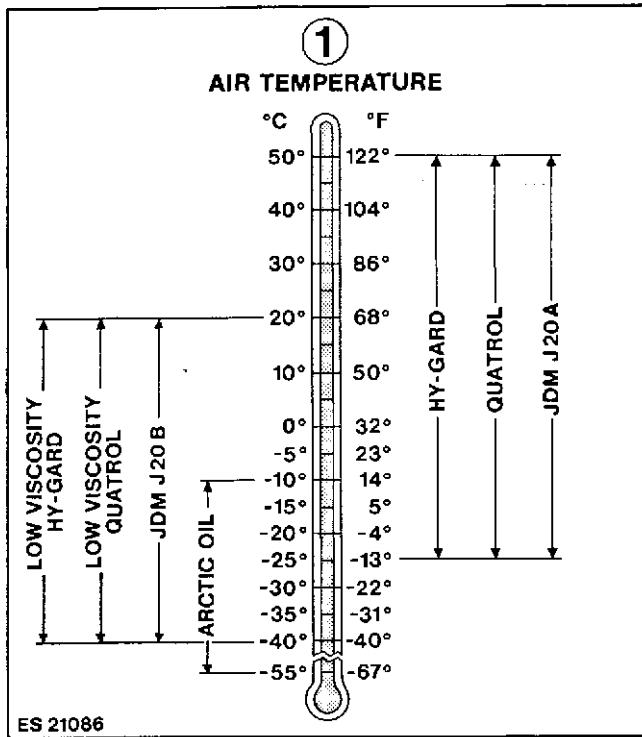

Fig. 2 – Oil Viscosity at Expected Temperature

Fig. 3 – Oil Viscosity at Expected Temperature

John Deere HY-GARD[®] transmission and hydraulic oil is recommended.

John Deere API GL-5 gear oil is recommended.

You may also use QUATROL[®] oil, or other oils meeting John Deere Standard JDM J20A or JDM J20B.

You may also use other EP transmission oils meeting performance requirements of:

- API Service Classification GL-5
- Military Specification MIL-L-2105B
- Military Specification MIL-L-2105C

For temperatures below -40°C (-40°F) use Arctic Oil (API-CC/SC, MIL-L-46167).

At temperature below -35°C (-31°F) use Arctic Oil (API-CC/SC, MIL-L-10324A).

Brake Fluid for Hydraulic Operated Clutch

For tractors with hydraulic operated clutch (tractors with SG2 cab), use brake fluid meeting SAE standard J 1703.

Grease

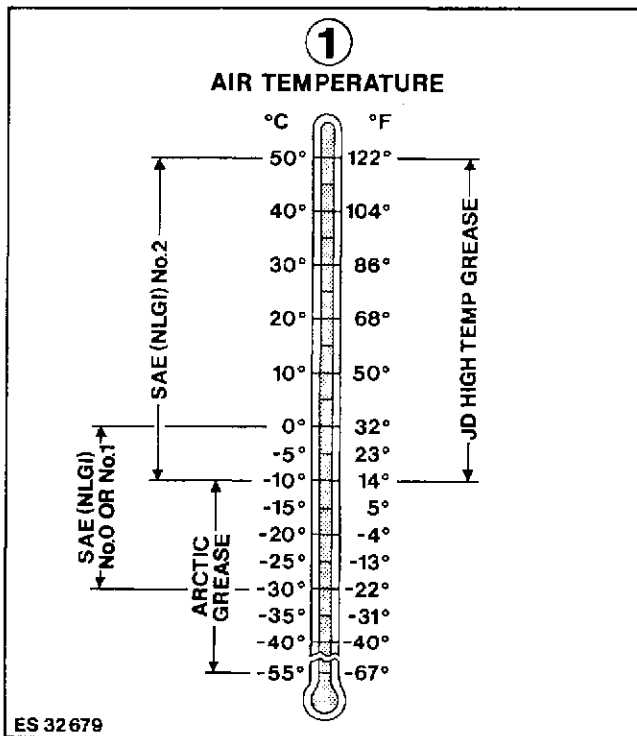

Fig. 4 — Grease to be used at Expected Temperature

John Deere High Temperature EP multipurpose Grease is recommended for all grease fittings. If other greases are used, use:

— SAE EP Multipurpose Grease

At temperatures below -30°C (-22°F) use Arctic Grease (MIL-G-10924 C).

Grease must be free of dust and other contamination.

Grease the tractor only when the engine is not running!

Clean grease fittings prior to greasing!

Storing Lubricants

The tractor can operate at top efficiency only if clean lubricants are used. Use clean containers to handle all lubricants. Store them in an area protected from dust, moisture, and other contamination.

Cooling Fluid

John Deere Engine Cooling Fluid is filled into the cooling system at the factory. It protects the engine against corrosion and against frost down to -36°C (-35°F).

IMPORTANT! Use only John Deere Cooling Fluid in the cooling system, independent of the season. Drain system and refill with fresh coolant every 2 years.

If no John Deere Engine Cooling Fluid is available use a mixture of 50 % ethylene-glycol antifreeze/ anticorrosion inhibitor and 50 % clear, soft water. This mixture guarantees engine protection against corrosion and against frost down to -36°C (-35°F).

Never use any cooling system sealing additives.

General Information

Carefully written and illustrated instructions are included in the tractor operator's manual. Remind your customer to follow the recommendations in these instructions.

For your convenience when servicing the tractor, the following chart shows capacities for the various components.

Component	Capacity	Service Interval
Engine crankcase	Without filter change: 8.0 liters (2.1 U.S.gal.) With filter change: 8.5 liters (2.25 U.S.gal.)	Every 10 operating hours: check oil level Every 200 operating hours: oil change Every 200 operating hours: filter change*
Engine coolant	Without operator's cab 13.0 liters (3.4 U.S.gal.) With operator's cab 15.0 liters (3.95 U.S.gal.)	Change coolant every two years
Transmission/hydraulic system (including oil reservoir and oil cooler)		
Synchronized transmission:	Dry system:	
1640, 1840 and 2040	59.0 liters (15.6 U.S.gal.)	Every 50 operating hours: check oil level
1640 and 2040 with heavy-duty final drives and 2040 S	64.0 liters (16.9 U.S.gal.)	Every 500 operating hours: filter change**
	Oil change:	
1640, 1840 and 2040	51.0 liters (13.5 U.S.gal.)	Every 1000 operating hours: oil change
1640 and 2040 with heavy-duty final drives and 2040 S	56.0 liters (14.8 U.S.gal.)	Every 1000 operating hours: Change hydrostatic steering filter
Collar shift transmission	Dry system:	Every 1000 operating hours: Clean hydraulic pump stroke control valve filter
1640, 1840 and 2040	47.0 liters (12.4 U.S.gal.)	
1640 and 2040 with heavy-duty final drives	52.0 liters (13.75 U.S.gal.)	
	Oil change:	
1640, 1840 and 2040	39.0 liters (10.3 U.S.gal.)	
1640 and 2040 with heavy-duty final drives	44.0 liters (11.6 U.S.gal.)	
Oil reservoir	4 liters (1.1 U.S.gal.)	
Oil cooler	2 liters (0.5 U.S.gal.)	
Mechanical front wheel drive	Axle housing:	Every 100 operating hours: check oil level
— up to serial no. 449 999 L	6.5 liters (1.7 U.S.gal.)	Every 1000 operating hours: oil change***
— from serial no. 450 000 L	7.0 liters (1.85 U.S.gal.)	
	Final drives:	
— up to serial no. 449 999 L	1.0 liter (0.3 U.S.gal.) each	
— from serial no. 450 000 L	0.75 liters (0.2 U.S.gal.) each	
Hydraulic operated clutch (tractors with SG2 cab)	300 cm ³ (10.5 fl.oz.)	Change brake fluid every two years

* Change engine oil and crankcase filter element after the first 100 and 200 hours of operation. Thereafter change oil and filter element after every 200 hours of operation.

** Replace transmission/hydraulic filter element after the first 50 hours of operation, after the first 500 hours and thereafter every 500 hours of operation.

*** On tractors with MFWD, first oil change after 100 hours of operation. Thereafter every 1000 hours of operation.

Component	Lubricant	Service Interval
Clutch throw-out bearing (when equipped with grease fitting)	John Deere High Temperature EP-multipurpose grease	Every 100 operating hours: lubricate with three strokes of grease gun
Front wheel bearings	John Deere High Temperature EP multipurpose grease or SAE EP multipurpose grease	Every 1000 operating hours: clean and pack with grease
Grease fittings	John Deere High Temperature EP multipurpose grease or SAE EP multipurpose grease	
Front axle		When necessary, lubricate every 10 operating hours. Under normal conditions: lubricate every 50 operating hours
Universal-jointed shafts of mechanical front wheel drive		When necessary, lubricate every 10 operating hours. Under normal conditions: lubricate every 50 operating hours
Rear axle bearings		When necessary, lubricate every 10 operating hours. Under normal conditions: lubricate every 500 operating hours
Three-point hitch		Every 200 operating hours: lubricate
Front hitch		Every 200 operating hours: lubricate
Front PTO drive shaft		Every 200 operating hours: lubricate

Engine Crankcase

CHECKING OIL LEVEL

With the tractor on level ground and the engine stopped for 10 minutes or more, check crankcase oil level. If the oil level is down to the lower mark on the dipstick, add sufficient John Deere Torq-Gard Supreme Engine Oil or its equivalent of the proper viscosity to bring the level to the upper mark.

Service Interval: At predelivery and after every 10 hours.

OIL AND FILTER CHANGE

NOTE: Drain oil with engine shut off, however with engine oil warm.

1. Remove drain plug.
2. While oil is draining, replace filter element (every 200 hours).

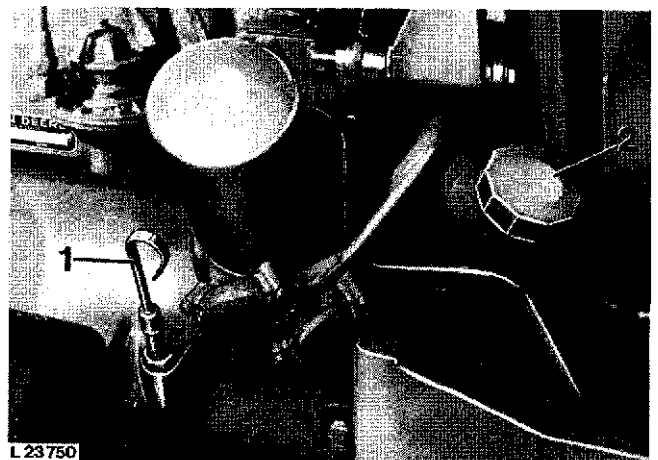

Fig. 5 – Engine Oil Dipstick and Filler Cap

- 1 Dipstick
- 2 Filler cap

3. Remove filter element (turn counterclockwise) and clean mounting surface.

This as a preview PDF file from best-manuals.com



Download full PDF manual at best-manuals.com