

2032R and 2038R Compact Utility Tractors Diagnostic and Repair Manual

TECHNICAL MANUAL 2032R and 2038R Compact Utility Tractors Diagnostic and Repair Manual

TM166819 01OCT24 (ENGLISH)

For complete service information also see:

Engine Component Technical Manual CTM120419
Service ADVISOR™ Machine Connection
Information..... CTM441

John Deere Augusta Works
PRINTED IN U.S.A.

Contents

Foreword

Section 10 General Information

Group 05A Safety	10 - 2
Group 05B General References	10 - 24
Group 05C Technical Specific References	10 - 28
Group 05D Fuel and Lubricants	10 - 34
Group 05E Serial Number Locations	10 - 41

Section 20 Engine Repair

Group 05 Engine	20 - 2
Group 10 Cooling System	20 - 25

Section 30 Fuel, Air Intake, and Exhaust Repair

Group 05 Fuel	30 - 2
Group 10 Air Intake	30 - 9

Section 40 Electrical Repair

Group 05 Electrical Connector Repair	40 - 2
Group 10 Battery, Starter, and Alternator	40 - 3
Group 15 Electrical System Components	40 - 13

Section 50 Drive Systems and Transmission Repair

Group 05 Power Train	50 - 2
Group 10 Mechanical Front Wheel Drive	50 - 26
Group 15 Differential	50 - 62
Group 20 PTO	50 - 82

Section 60 Steering Repair

Group 05 Steering	60 - 2
-----------------------------	--------

Section 61 Brake Repair

Group 05 Brake	61 - 2
--------------------------	--------

Section 70 Hydraulics Repair

Group 05 Hydraulic Pump and Filter	70 - 2
Group 10 Rockshaft	70 - 8
Group 15 Range Control and Three Point Hitch	70 - 18
Group 20 Selective Control Valve	70 - 19
Group 25 Hydraulic Lines	70 - 37

Section 80 Miscellaneous Repair

Group 05 Hood and Side Panels	80 - 2
Group 10 Fenders	80 - 4
Group 15 Wheels	80 - 9

Section 90 Cab/Open Operator's Station Repair

Group 05 Seat and Support	90 - 2
Group 10 Control Console	90 - 7
Group 15 Roll-Gard	90 - 13
Group 25 Open Operator Station Components	90 - 15

Section 211 Diagnostic Trouble Codes

Group 05 General References	211 - 2
Group ECU Engine Control Unit (ECU) Diagnostic Trouble Codes	211 - 9
Group ICC Instrument Cluster Control (ICC) Diagnostic Trouble Codes	211 - 15

Group HOC Height of Cut (HOC) Diagnostic Trouble Codes	211 - 19
Group EIC Engine Interface Control Unit (EIC) Diagnostic Trouble Codes.	211 - 21

Section 212 Observable Symptoms and System Diagnostics

Group 05 General References212 - 2
Group 20 Engine System Diagnostics212 - 3
Group 30 Fuel, Air Intake, Exhaust, and Cooling System Diagnostics.212 - 4
Group 40 Electrical System Diagnostics212 - 6
Group 45 Electronic Control Unit System Diagnostics	212 - 10
Group 50 Drive Systems and Transmission System Diagnostics	212 - 13
Group 60 Steering System Diagnostics.	212 - 19
Group 61 Brakes System Diagnostics	212 - 21
Group 70 Hydraulic System Diagnostics	212 - 23

Section 220 Engine Operation, Test, and Adjustments

Group 05 General References220 - 2
Group 10 Calibrations, Preliminary Checks and Operational Checks220 - 3

Section 230 Fuel, Air Intake, Exhaust, and Cooling Operation, Test, and Adjustments

Group 05 General References230 - 2
Group 10 Calibrations, Preliminary Checks and Operational Checks230 - 4
Group 50 Tests and Adjustments	230 - 10

Section 240A Electrical General and Theory of Operation

Group 05 General References40A - 2
Group 20 Electrical Theory of Operation	40A - 10

Section 240B Electrical Schematics

Group 05 General References40B - 2
Group 30AA Starting and Charging—With ECU (SE1A)40B - 6
Group 30BA Lighting—Without License Light (SE2A)40B - 7
Group 30BB Lighting—With License Light (SE2B)40B - 8
Group 30BC Brake Switch, Horn, And Rear Trailer Connector (SE2C)40B - 9
Group 30CA Instrument Cluster Control (ICC) (SE3)	40B - 10
Group 30DA Engine Control Unit (ECU) (SE4)	40B - 11
Group 30EA Vehicle Control Unit (VCU) (SE6)	40B - 12
Group 30FA Right Hand Fender (SE7)	40B - 13
Group 30GA Third EH SCV (SE8)	40B - 15

Section 240C Electrical Components and Connectors

Group 05 General References	40C - 3
Group 40A Electrical Assemblies, Modules, and Control Units.	40C - 9
Group 40B Sensors	40C - 36
Group 40C Resistors/Condensers/Capacitors	40C - 57
Group 40E Lights	40C - 63
Group 40F Fuses	40C - 85
Group 40G Charging.	40C - 107
Group 40H Monitoring/Warning Devices	40C - 115
Group 40K Relays.	40C - 121
Group 40M Motors	40C - 131
Group 40S Switches.	40C - 135
Group 40V Diodes.	40C - 169
Group 40WA Wiring Harnesses	40C - 173
Group 40X Interconnects.	40C - 207
Group 40Y Solenoids and Electrically Actuated Mechanical Devices	40C - 250
Group 40Z Ground Points	40C - 264

Section 240D Electrical Tests and Adjustments

Group 05 General References	40D - 2
Group 50 Tests and Adjustments	40D - 39

Section 245 Electronic Control Units

Group 05 General References	245 - 2
Group 10 Calibrations, Preliminary Checks and Operational Checks	245 - 9
Group 20 Theory of Operation	245 - 23
Group 40 Component and Connector Information	245 - 29
Group 50 Test and Adjustments	245 - 30
Group ICC Instrument Cluster Control (ICC)	245 - 34
Group ECU Engine Control Unit (ECU)	245 - 38
Group VCU Height of Cut Control Unit (HOC)	245 - 41
Group EIC Engine Interface Control Unit (EIC)	245 - 43

Section 250 Drive Systems and Transmission Operation, Test, and Adjustments

Group 05 General References	250 - 2
Group 10 Calibrations, Preliminary Checks and Operational Checks	250 - 7
Group 20 Theory of Operation	250 - 19
Group 30 Schematics	250 - 27
Group 40 Component and Connector Information	250 - 29
Group 50 Tests and Adjustments	250 - 47

Section 260 Steering Operation, Test, and Adjustments

Group 05 General References	260 - 2
Group 10 Calibrations, Preliminary Checks and Operational Checks	260 - 5
Group 20 Theory of Operation	260 - 11
Group 30 Schematics	260 - 16
Group 40 Component and Connector Information	260 - 17
Group 50 Tests and Adjustments	260 - 23

Section 261 Brakes Operation, Test, and Adjustments

Group 05 General References	261 - 2
Group 10 Calibrations, Preliminary Checks and Operational Checks	261 - 3
Group 20 Theory of Operation	261 - 5
Group 40 Component and Connector Information	261 - 7
Group 50 Tests and Adjustments	261 - 9

Section 270 Hydraulics Operation, Test, and Adjustments

Group 05 General References	270 - 2
Group 10 Calibrations, Preliminary Checks and Operational Checks	270 - 8
Group 20 Theory of Operation	270 - 12
Group 30 Schematics	270 - 30
Group 40 Component and Connector Information	270 - 31
Group 50 Tests and Adjustments	270 - 69

Section 290 Cab/Open Operators Station Operation, Test, and Adjustments

Group 05 General References	290 - 2
Group 20 Theory of Operation	290 - 3
Group 30 Schematics	290 - 6
Group 40 Component and Connector Information	290 - 7

Section 299 Service Tools

Group 05A General References	299 - 2
Group 05C Dealer Fabricated and Service Tools	299 - 3

Foreword

This manual is written for an experienced technician. Essential tools required in performing certain service work are identified in this manual and are recommended for use.

Live with safety: Read the safety messages in the introduction of this manual and the cautions presented throughout the text of the manual.

□ This is the safety-alert symbol. When you see this symbol on the machine or in this manual, be alert to the potential for personal injury.

Technical manuals are divided in two parts: repair and operation and tests. Repair sections tell how to repair the components. Operation and tests sections help you identify the majority of routine failures quickly.

Information is organized in groups for the various components requiring service instruction. At the beginning of each group are summary listings of all applicable essential tools, service equipment and tools, other materials needed to do the job, service parts kits, specifications, wear tolerances, and torque values.

Technical Manuals are concise guides for specific machines. They are on-the-job guides containing only the vital information needed for diagnosis, analysis, testing, and repair.

Fundamental service information is available from other sources covering basic theory of operation, fundamentals of troubleshooting, general maintenance, and basic type of failures and their causes.

DX, TMIFC-19-20130513

Section 10 - General Information

Contents

Group 05A - Safety

Work In Ventilated Area
Recognize Safety Information
Avoid Backover Accidents
Prevent Machine Runaway
Avoid Contact with Agricultural Chemicals
Clean Vehicle of Hazardous Pesticides
Use a Safety Chain
Work in Clean Area
Decommissioning — Proper Recycling and Disposal of Fluids and Components
Avoid Harmful Asbestos Dust
Avoid Hot Exhaust
Clean Exhaust Filter Safely
Handle Fuel Safely—Avoid Fires
Prepare for Emergencies
Handle Fluids Safely—Avoid Fires
Avoid High-Pressure Fluids
Install All Guards
Use Proper Lifting Equipment
Illuminate Work Area Safely
Live With Safety
Service Machines Safely
Support Machine Properly
Remove Paint Before Welding or Heating
Park Machine Safely
Stay Clear of Rotating Drivelines
Follow Safety Instructions
Use Proper Tools
Service Tires Safely
Keep ROPS Installed Properly
Construct Dealer-Made Tools Safely
Practice Safe Maintenance
Understand Signal Words
Replace Safety Signs
Avoid Heating Near Pressurized Fluid Lines
Wear Protective Clothing
Service Accumulator Systems Safely
Handling Batteries Safely
Handle Agricultural Chemicals Safely
Service Cooling System Safely
Use Steps and Handholds Correctly
Transport Tractor Safely

Group 05B - General References

Deliver Safely
Information Available in Sections, Groups and Subgroups
Glossary of Terms
Trademarks

Group 05C - Technical Specific References

Unified Inch Bolt and Screw Torque Values
Metric Bolt and Screw Torque Values
Metric Cap Screw Torque Values—Grade 7
Gasket Sealant Application
Service Recommendations for Flat Face O-Ring Seal Fittings

Group 05D - Fuel and Lubricants

Handling and Storing Diesel Fuel
Engine Oil
Engine Oil
Alternative and Synthetic Lubricants
Lubricant Storage
Mixing of Lubricants
Multipurpose Extreme Pressure (EP) Grease
Transmission and Hydraulic Oil

Group 05E - Serial Number Locations

Serial Numbers
Machine Product Identification Number
Engine Serial Number
Transmission Serial Number

Work In Ventilated Area

Engine exhaust fumes can cause sickness or death. If it is necessary to run an engine in an enclosed area, remove the exhaust fumes from the area with an exhaust pipe extension. If you do not have an exhaust pipe extension, open the doors and get outside air into the area.

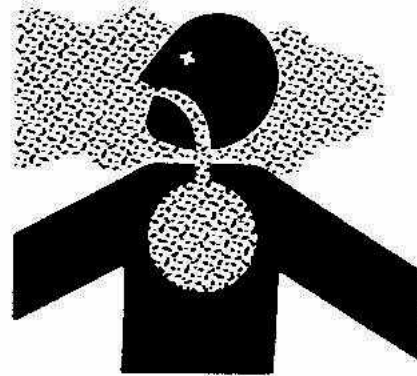

TS220-UN: Engine exhaust fumes

DX,AIR-19-19990217

Recognize Safety Information

This is a safety-alert symbol. When you see this symbol on your machine or in this manual, be alert to the potential for personal injury. Follow recommended precautions and safe operating practices.

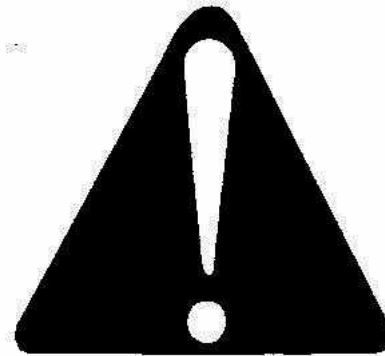

T81389-UN: Safety-alert symbol

DX,ALERT-19-20220829

by BestManuals.com

Avoid Backover Accidents

Before moving machine, be sure that all persons are clear of machine path. Turn around and look directly for best visibility. Use a signal person when backing if view is obstructed or when in close quarters.

Do not rely on a camera to determine if personnel or obstacles are behind the machine. The system can be limited by many factors including maintenance practices, environmental conditions, and operating range.



PC10857XW-UN: Avoid Backover Accidents

DX,AVOID,BACKOVER,ACCIDENTS-19-20100830

Prevent Machine Runaway

Avoid possible injury or death from machinery runaway.
Do not start engine by shorting across starter terminals.
Machine will start in gear if normal circuitry is bypassed.

NEVER start engine while standing on ground. Start engine only from operator's seat, with transmission in neutral or park.



TS177-UN: Machinery Runaway

DX,BYPAS1-19-19980929

Avoid Contact with Agricultural Chemicals



This enclosed cab does not protect against inhaling vapor, aerosol or dust.

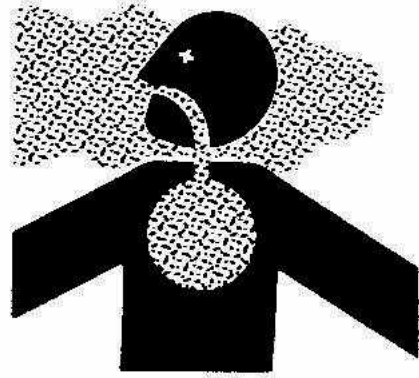

TS220-UN: Harmful Pesticides



TS272-UN: Pesticide Use

1. When operating in an environment where pesticides are present, wear a long-sleeved shirt, long-legged pants, shoes, and socks.
2. If pesticide use instructions require respiratory protection, wear an appropriate respirator inside the cab.
3. Wear personal protective equipment as required by the pesticide use instructions when leaving the enclosed cab:
 - into a treated area
 - to work with contaminated application equipment such as nozzles which must be cleaned, changed or redirected
 - to become involved with mixing and loading activities
4. Before re-entering the cab, remove protective equipment and store either outside the cab in a closed box or some other type of sealable container or inside the cab in a pesticide resistant container, such as a plastic bag.
5. Clean your shoes or boots to remove soil or other contaminated particles prior to entering the cab.

DX.CABS1-19-20090325

Clean Vehicle of Hazardous Pesticides



During application of hazardous pesticides, pesticide residue can build up on the inside or outside of the vehicle. Clean vehicle according to use instructions of hazardous pesticides.

When exposed to hazardous pesticides, clean exterior and interior of vehicle daily to keep free of the accumulation of visible dirt and contamination.

1. Sweep or vacuum the floor of cab.
2. Clean headliners and inside cowlings of cab.
3. Wash entire exterior of vehicle.
4. Dispose of any wash water with hazardous concentrations of active or non-active ingredients according to published regulations or directives.

DX,CABS2-19-20010724

Use a Safety Chain

A safety chain will help control drawn equipment should it accidentally separate from the drawbar.

Using the appropriate adapter parts, attach the chain to the tractor drawbar support or other specified anchor location. Provide only enough slack in the chain to permit turning.

See your John Deere dealer for a chain with a strength rating equal to or greater than the gross weight of the towed machine. Do not use safety chain for towing.

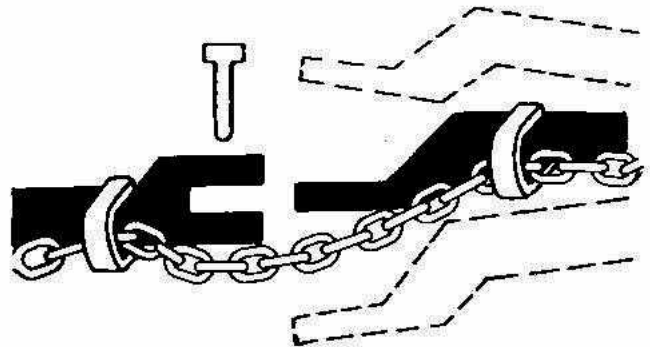

TS217-UN: Safety Chain

DX,CHAIN-19-19930303

by BestManuals.com

Work in Clean Area

Before starting a job:

- Clean work area and machine.
- Have the right parts on hand.
- Make sure you have all necessary tools to do your job.
- Read all instructions thoroughly; do not attempt shortcuts.

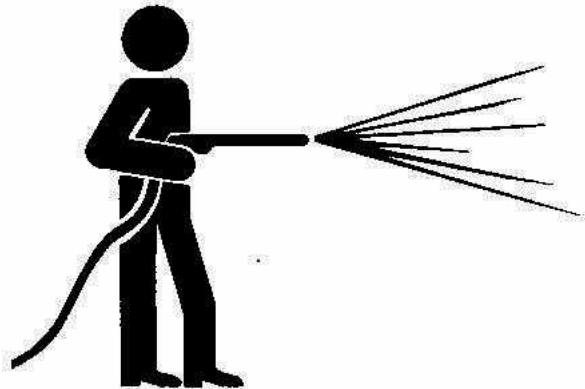

T6642EJ-UN: Clean Work Area

DX,CLEAN-19-19900604

Decommissioning — Proper Recycling and Disposal of Fluids and Components

Safety and environmental stewardship measures must be taken into account when decommissioning a machine and/or component. These measures include the following:

- Use appropriate tools and personal protective equipment such as clothing, gloves, face shields or glasses, during the removal or handling of objects and materials.
- Follow instructions for specialized components.
- Release stored energy by lowering suspended machine elements, relaxing springs, disconnecting the battery or other electrical power, and releasing pressure in hydraulic components, accumulators, and other similar systems.
- Minimize exposure to components which may have residue from agricultural chemicals, such as fertilizers and pesticides. Handle and dispose of these components appropriately.
- Carefully drain engines, fuel tanks, radiators, hydraulic cylinders, reservoirs, and lines before recycling components. Use leak-proof containers when draining fluids. Do not use food or beverage containers.
- Do not pour waste fluids onto the ground, down a drain, or into any water source.
- Observe all national, state, and local laws, regulations, or ordinances governing the handling or disposal of waste fluids (example: oil, fuel, coolant, brake fluid); filters; batteries; and, other substances or parts. Burning of flammable fluids or components in other than specially designed incinerators may be prohibited by law and could result in exposure to harmful fumes or ashes.
- Service and dispose of air conditioning systems appropriately. Government regulations may require a certified service center to recover and recycle air conditioning refrigerants which could damage the atmosphere if allowed to escape.
- Evaluate recycling options for tires, metal, plastic, glass, rubber, and electronic components which may be recyclable, in part or completely.
- Contact your local environmental or recycling center, or your John Deere dealer for information on the proper way to recycle or dispose of waste.

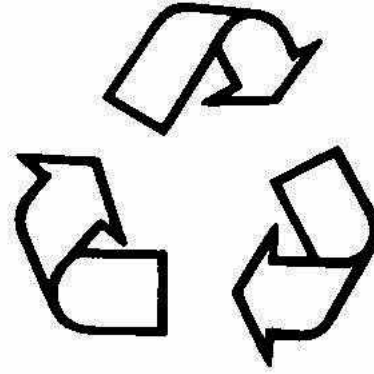

TS1133-UN: Recycle Waste

DX,DRAIN-19-20150601

Avoid Harmful Asbestos Dust

Avoid breathing dust that may be generated when handling components containing asbestos fibers. Inhaled asbestos fibers may cause lung cancer.

Components in products that may contain asbestos fibers are brake pads, brake band and lining assemblies, clutch plates, and some gaskets. The asbestos used in these components is usually found in a resin or sealed in some way. Normal handling is not hazardous as long as airborne dust containing asbestos is not generated.

Avoid creating dust. Never use compressed air for cleaning. Avoid brushing or grinding material containing asbestos. When servicing, wear an approved respirator. A special vacuum cleaner is recommended to clean asbestos. If not available, apply a mist of oil or water on the material containing asbestos.

Keep bystanders away from the area.

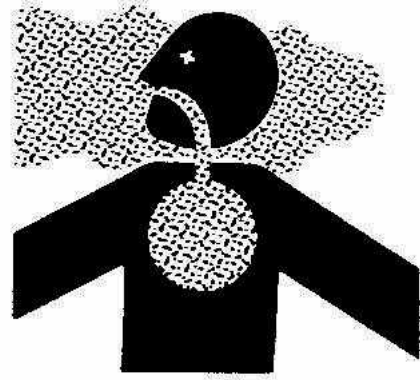

TS220-UN: Asbestos Dust

DX,DUST-19-19910315

Avoid Hot Exhaust

Servicing machine or attachments with engine running can result in serious personal injury. Avoid exposure and skin contact with hot exhaust gases and components.

Exhaust parts and streams become very hot during operation. Exhaust gases and components reach temperatures hot enough to burn people, ignite, or melt common materials.

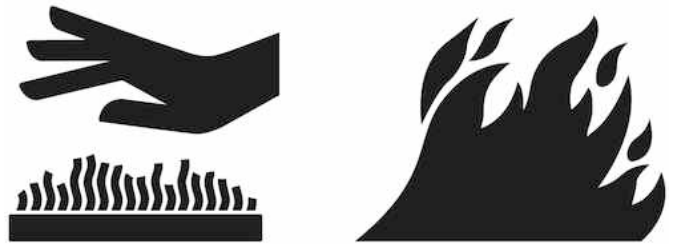

RG17488-UN: Safety—Hot Parts

DX,EXHAUST-19-20090820

Clean Exhaust Filter Safely

During exhaust filter cleaning operations, the engine may run at elevated idle and hot temperatures for an extended period of time. Exhaust gases and exhaust filter components reach temperatures hot enough to burn people, or ignite or melt common materials.

Keep machine away from people, animals, or structures which may be susceptible to harm or damage from hot exhaust gases or components. Avoid potential fire or explosion hazards from flammable materials and vapors near the exhaust. Keep exhaust outlet away from people and anything that can melt, burn, or explode.

Closely monitor machine and surrounding area for smoldering debris during and after exhaust filter cleaning.

Adding fuel while an engine is running can create a fire or explosion hazard. Always stop engine before refueling machine and clean up any spilled fuel.

Always make sure that engine is stopped while hauling machine on a truck or trailer.

Contact with exhaust components while still hot can result in serious personal injury.

Avoid contact with these components until cooled to safe temperatures.

If service procedure requires engine to be running:

- Only engage power- • Ensure that other driven parts required by people are clear of service procedure operator station and machine

Keep hands, feet, and clothing away from power-driven parts.

Always disable movement (neutral), set the parking brake or mechanism and disconnect power to attachments or tools before leaving the operator's station.

Shut off engine and remove key (if equipped) before leaving the machine unattended.



TS227-UN: Fire Safety



TS271-UN: Hand Over Flame

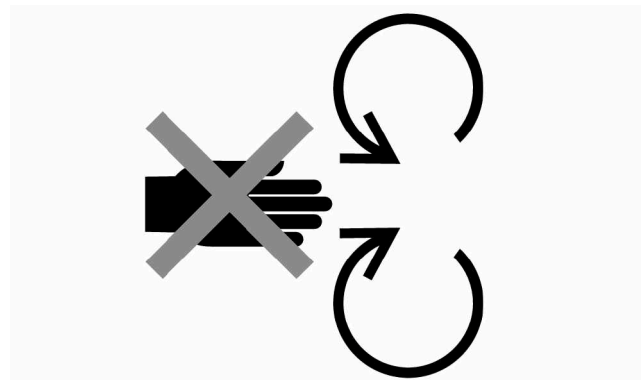

TS1693-UN: Moving Parts



TS1695-UN: Stop

DX,EXHAUST,FILTER-19-20110112

Handle Fuel Safely—Avoid Fires

Handle fuel with care: it is highly flammable. Do not refuel the machine while smoking or when near open flame or sparks.

Always stop engine before refueling machine. Fill fuel tank outdoors.

Prevent fires by keeping machine clean of accumulated trash, grease, and debris. Always clean up spilled fuel.

Use only an approved fuel container for transporting flammable liquids.

Never fill fuel container in pickup truck with plastic bed liner. Always place fuel container on ground before refueling. Touch fuel container with fuel dispenser nozzle before removing can lid. Keep fuel dispenser nozzle in contact with fuel container inlet when filling.

Do not store fuel container where there is an open flame, spark, or pilot light such as within a water heater or other appliance.



TS202-UN: Avoid Fires

DX,FIRE1-19-20111012

Prepare for Emergencies

Be prepared if a fire starts.

Keep a first aid kit and fire extinguisher handy.

Keep emergency numbers for doctors, ambulance service, hospital, and fire department near your telephone.

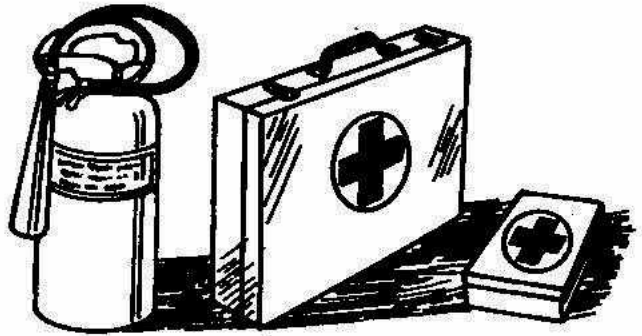

TS291-UN: First Aid Kit

DX,FIRE2-19-19930303

Handle Fluids Safely—Avoid Fires

When you work around fuel, do not smoke or work near heaters or other fire hazards.

Store flammable fluids away from fire hazards. Do not incinerate or puncture pressurized containers.

Make sure machine is clean of trash, grease, and debris.

Do not store oily rags; they can ignite and burn spontaneously.



TS227-UN: Avoid Fires

DX,FLAME-19-19980929

Avoid High-Pressure Fluids

Inspect hydraulic hoses periodically – at least once per year – for leakage, kinking, cuts, cracks, abrasion, blisters, corrosion, exposed wire braid or any other signs of wear or damage.

Replace worn or damaged hose assemblies immediately with John Deere approved replacement parts.

Escaping fluid under pressure can penetrate the skin causing serious injury.

Avoid the hazard by relieving pressure before disconnecting hydraulic or other lines. Tighten all connections before applying pressure.

Search for leaks with a piece of cardboard. Protect hands and body from high-pressure fluids.

If an accident occurs, see a doctor immediately. Any fluid injected into the skin must be surgically removed within a few hours or gangrene may result. Doctors unfamiliar with this type of injury should reference a knowledgeable medical source. Such information is available in English from Deere & Company Medical Department in Moline, Illinois, U.S.A., by calling 1-800-822-8262 or +1 309-748-5636.

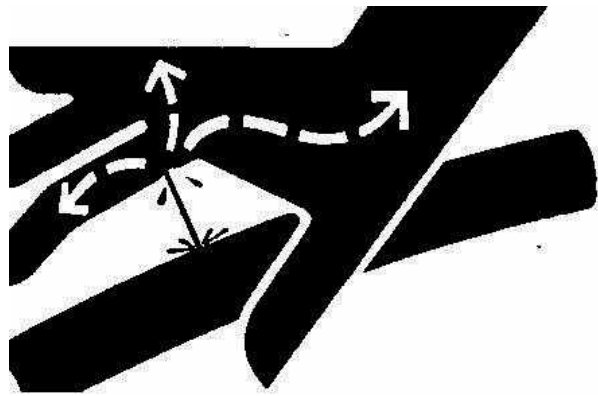

X9811-UN: High Pressure

DX,FLUID-19-20111012

Install All Guards

Rotating cooling system fans, belts, pulleys, and drives can cause serious injury.

Keep all guards in place at all times during engine operation.

Wear close-fitting clothes. Stop the engine and be sure fans, belts, pulleys, and drives are stopped before making adjustments, connections, or cleaning near fans and their drive components.

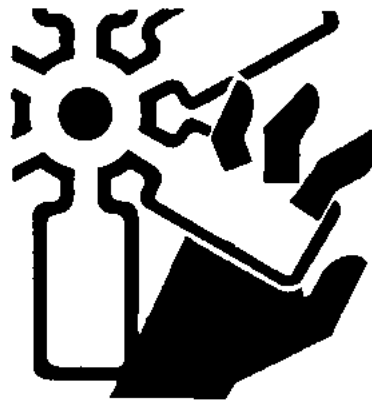

TS677-UN: SafetyFan

DX,GUARDS-19-20090818

Use Proper Lifting Equipment

Lifting heavy components incorrectly can cause severe injury or machine damage.

Follow recommended procedure for removal and installation of components in the manual.

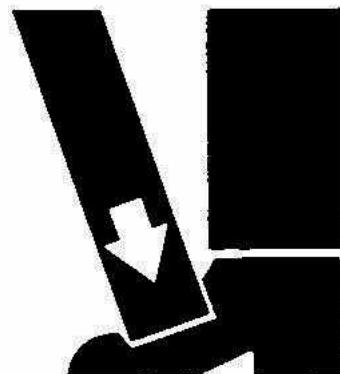

TS226-UN: Proper Lifting Equipment

DX,LIFT-19-19900604

Illuminate Work Area Safely

Illuminate your work area adequately but safely. Use a portable safety light for working inside or under the machine. Make sure the bulb is enclosed by a wire cage. The hot filament of an accidentally broken bulb can ignite spilled fuel or oil.

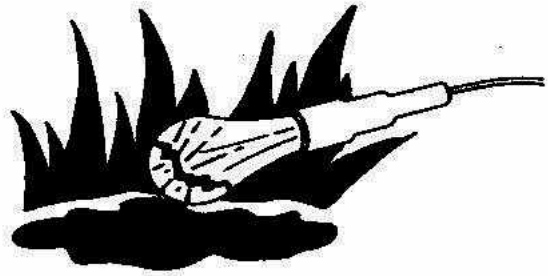

TS223-UN: Work Area Safety

DX,LIGHT-19-19900604

Live With Safety

Before returning machine to customer, make sure machine is functioning properly, especially the safety systems. Install all guards and shields.



TS231-19: Safety Systems

DX,LIVE-19-19920925

by BestManuals.com

Service Machines Safely

Tie long hair behind your head. Do not wear a necktie, scarf, loose clothing, or necklace when you work near machine tools or moving parts. If these items were to get caught, severe injury could result.

Remove rings and other jewelry to prevent electrical shorts and entanglement in moving parts.

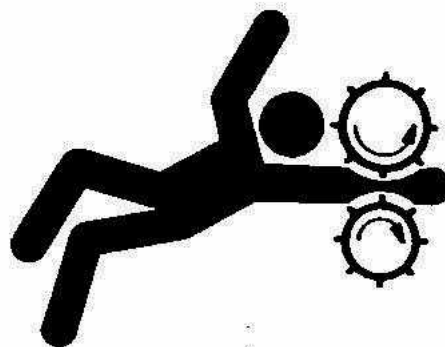

TS228-UN: Moving Parts

DX,LOOSE-19-19900604

Support Machine Properly

Always lower the attachment or implement to the ground before you work on the machine. If the work requires that the machine or attachment be lifted, provide secure support for them. If left in a raised position, hydraulically supported devices can settle or leak down.

Do not support the machine on cinder blocks, hollow tiles, or props that may crumble under continuous load. Do not work under a machine that is supported solely by a jack. Follow recommended procedures in this manual.

When implements or attachments are used with a machine, always follow safety precautions listed in the implement or attachment operator's manual.

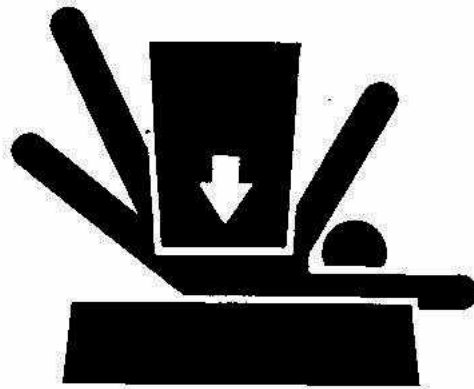

TS229-UN: Support Properly

DX,LOWER-19-20000224

Remove Paint Before Welding or Heating

Avoid potentially toxic fumes and dust.

Hazardous fumes can be generated when paint is heated by welding, soldering, or using a torch.

Remove paint before heating:

- Remove paint a minimum of 100 mm (4 in.) from area to be affected by heating. If paint cannot be removed, wear an approved respirator before heating or welding.
- If you sand or grind paint, avoid breathing the dust. Wear an approved respirator.
- If you use solvent or paint stripper, remove stripper with soap and water before welding. Remove solvent or paint stripper containers and other flammable material from area. Allow fumes to disperse at least 15 minutes before welding or heating.

Do not use a chlorinated solvent in areas where welding will take place.

Do all work in an area that is well ventilated to carry toxic fumes and dust away.

Dispose of paint and solvent properly.

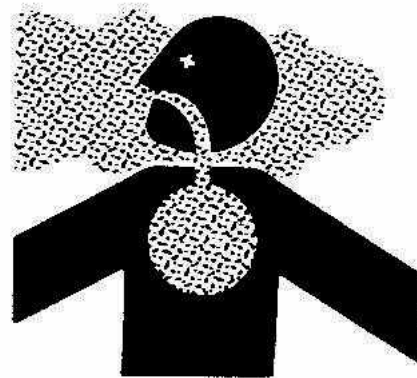

TS220-UN: Toxic Fumes

DX,PAINT-19-20020724

Park Machine Safely

Before working on the machine:

- Lower all equipment to the ground.
- Stop the engine and remove the key.
- Disconnect the battery ground strap.
- Hang a "DO NOT OPERATE" tag in operator station.

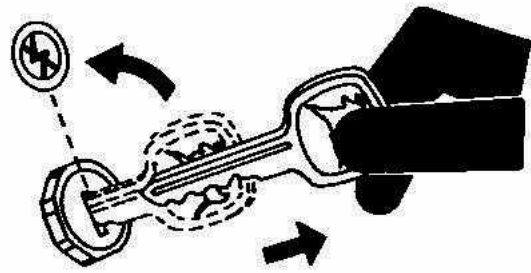

TS230-UN: Remove the Key

DX,PARK-19-19900604

Stay Clear of Rotating Drivelines

Entanglement in rotating driveline can cause serious injury or death.

Keep tractor master shield and driveline shields in place at all times. Make sure rotating shields turn freely. Only use power take-off driveshafts with adequate guards and shields.

Wear close fitting clothing. Stop the engine and be sure that PTO driveline is stopped before making adjustments, connections, or cleaning out PTO driven equipment.

Do not install any adapter device between the tractor and the primary implement PTO driveshaft that will allow a 1000 rpm tractor shaft to power a 540 rpm implement at speeds higher than 540 rpm.

Do not install any adapter device that results in a portion of the rotating implement shaft, tractor shaft, or the adapter to be unguarded. The tractor master shield shall overlap the end of the splined shaft and the added adaptor device as outlined in the table.

The angle at which the primary implement PTO driveshaft can be inclined may be reduced depending on the shape and size of the tractor master shield and the shape and size of the guard of the primary implement PTO driveshaft.

Do not raise implements high enough to damage the tractor master shield or guard of primary implement PTO driveshaft. Detach the PTO driveline shaft if it is necessary to increase implement height. (See Attaching/Detaching PTO Driveline)

When using Type 3/4 PTO, inclination and turning angles may be reduced depending on type of PTO master shield and coupling rails.

PTO Type	Diameter	Splines	$n \pm 5 \text{ mm (0.20 in.)}$
1	35 mm (1.378 in.)	6	85 mm (3.35 in.)
2	35 mm (1.378 in.)	21	85 mm (3.35 in.)
3	45 mm (1.772 in.)	20	100 mm (4.00 in.)
4	57.5 mm (2.264 in.)	22	100 mm (4.00 in.)



TS1644-UN: Rotating Drivelines

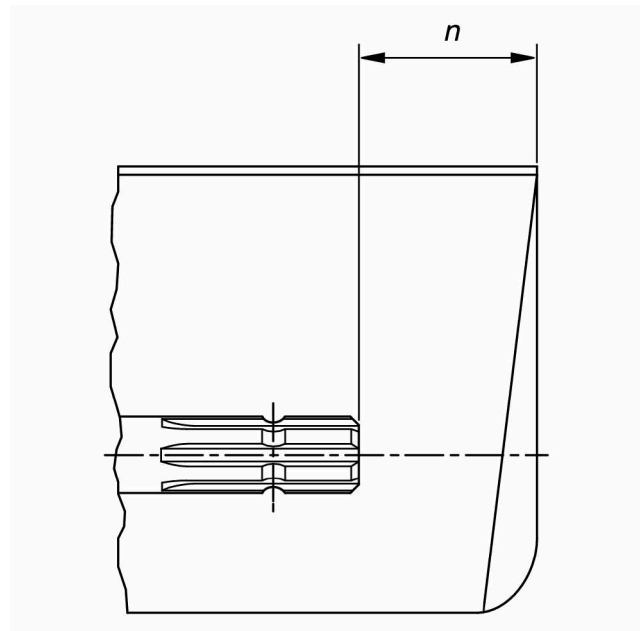

H96219-UN: Drivelines

DX,PTO-19-20170228

by BestManuals.com

Follow Safety Instructions

Carefully read all safety messages in this instruction. Read the product operators manual for operating instructions and safety messages. Do not let anyone operate without instruction. (A copy of the operators manual may also be available from the Service ADVISOR™ application.)

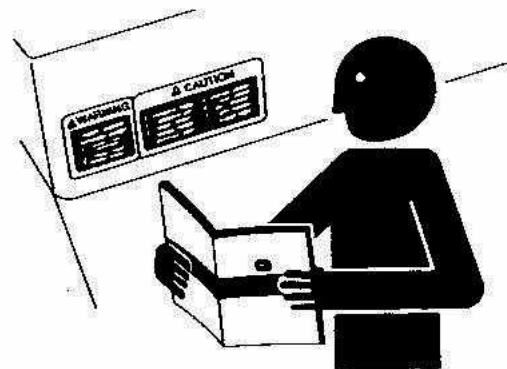

TS201-UN: Follow Safety Instructions

Service ADVISOR is a trademark of Deere & Company

DX,READ,INS-19-20090623

Use Proper Tools

Use tools appropriate to the work. Makeshift tools and procedures can create safety hazards.

Use power tools only to loosen threaded parts and fasteners.

For loosening and tightening hardware, use the correct size tools. DO NOT use U.S. measurement tools on metric fasteners. Avoid bodily injury caused by slipping wrenches.

Use only service parts meeting John Deere specifications.



TS779-UN: Proper Tools

DX,REPAIR-19-19990217

Service Tires Safely



Explosive separation of a tire and rim parts can cause serious injury or death.

Do not attempt to mount a tire unless you have the proper equipment and experience to perform the job.

Always maintain the correct tire pressure. Do not inflate the tires above the recommended pressure.

Never weld or heat a wheel and tire assembly. The heat can cause an increase in air pressure resulting in a tire explosion. Welding can structurally weaken or deform the wheel.

When inflating tires, use a clip-on chuck and extension hose long enough to allow you to stand to one side and NOT in front of or over the tire assembly. Use a safety cage if available.

Check wheels for low pressure, cuts, bubbles, damaged rims or missing lug bolts and nuts.

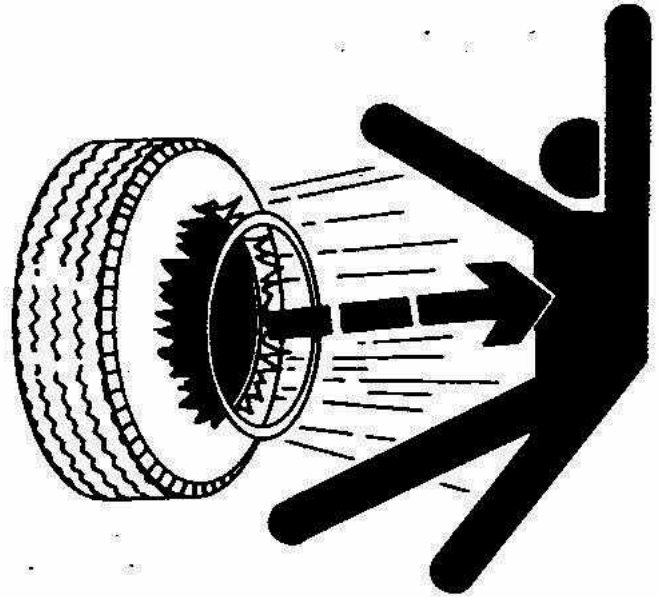

TS211-UN: Explosive Tire and Rim Parts

DX,RIM1-19-20081027

by BestManuals.com

Keep ROPS Installed Properly

Make certain all parts are reinstalled correctly if the roll-over protective structure (ROPS) is loosened or removed for any reason. Tighten mounting bolts to proper torque.

The protection offered by ROPS will be impaired if ROPS is subjected to structural damage, is involved in an overturn incident, or is in any way altered by welding, bending, drilling, or cutting. A damaged ROPS should be replaced, not reused.

The seat is part of the ROPS safety zone. Replace only with John Deere seat approved for your tractor.

Any alteration of the ROPS must be approved by the manufacturer.

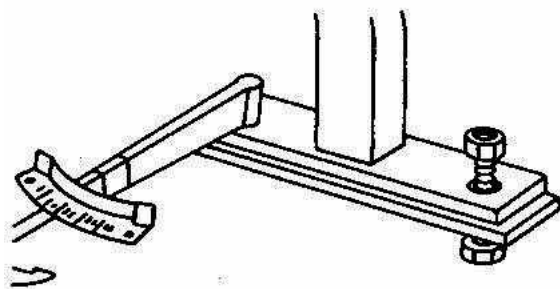

TS212-UN: Roll-Over Protective Structure

DX,ROPS3-19-20111012

Construct Dealer-Made Tools Safely

Faulty or broken tools can result in serious injury. When constructing tools, use proper, quality materials, and good workmanship.

Do not weld tools unless you have the proper equipment and experience to perform the job.

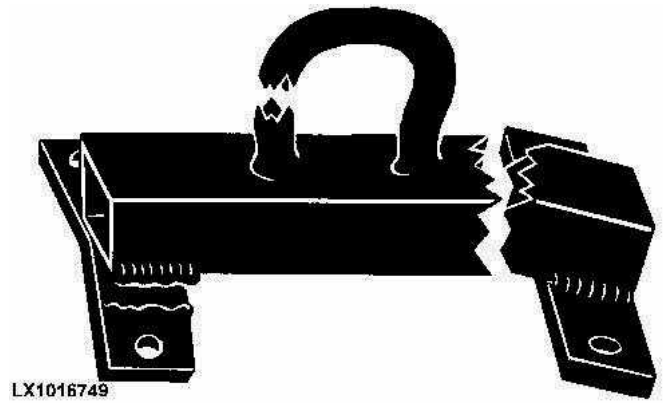

LX1016749

LX1016749-UN: Construct Dealer-Made Tools Safely

DX,SAFE,TOOLS-19-19971010

Practice Safe Maintenance

Understand service procedure before doing work. Keep area clean and dry.

Never lubricate, service, or adjust machine while it is moving. Keep hands, feet, and clothing away from power-driven parts. Disengage all power and operate controls to relieve pressure. Lower equipment to the ground. Stop the engine. Remove the key. Allow machine to cool.

Securely support any machine elements that must be raised for service work.

Keep all parts in good condition and properly installed. Fix damage immediately. Replace worn or broken parts. Remove any buildup of grease, oil, or debris.

On self-propelled equipment, disconnect battery ground cable (-) before making adjustments on electrical systems or welding on machine.

On towed implements, disconnect wiring harnesses from tractor before servicing electrical system components or welding on machine.

Falling while cleaning or working at height can cause serious injury. Use a ladder or platform to easily reach each location. Use sturdy and secure footholds and handholds.



TS218-UN: Keep Area Clean

DX,SERV-19-20170228

by BestManuals.com

Understand Signal Words

DANGER ; The signal word DANGER indicates a hazardous situation which, if not avoided, will result in death or serious injury.

WARNING ; The signal word WARNING indicates a hazardous situation which, if not avoided, could result in death or serious injury.

CAUTION ; The signal word CAUTION indicates a hazardous situation which, if not avoided, could result in minor or moderate injury. CAUTION may also be used to alert against unsafe practices associated with events which could lead to personal injury.

A signal word—DANGER, WARNING, or CAUTION—is used with the safety-alert symbol. DANGER identifies the most serious hazards. DANGER or WARNING safety signs are located near specific hazards. General precautions are listed on CAUTION safety signs. CAUTION also calls attention to safety messages in this manual.



WARNING

CAUTION

TS187-19: Signal Words

DX,SIGNAL-19-20161005

Replace Safety Signs

Replace missing or damaged safety signs. See the machine operator's manual for correct safety sign placement.

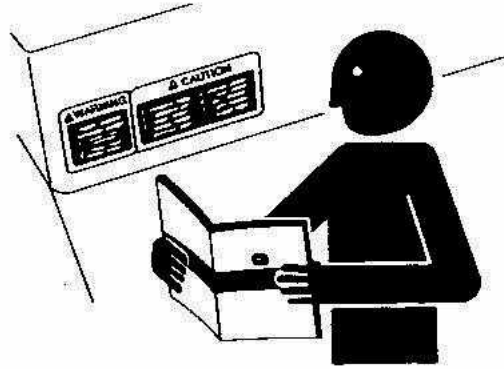

TS201-UN: Safety Signs

DX,SIGNS1-19-19900604

Avoid Heating Near Pressurized Fluid Lines

Flammable spray can be generated by heating near pressurized fluid lines, resulting in severe burns to yourself and bystanders. Do not heat by welding, soldering, or using a torch near pressurized fluid lines or other flammable materials. Pressurized lines can accidentally burst when heat goes beyond the immediate flame area.



TS953-UN: Flammable Spray

DX,TORCH-19-20041210

Wear Protective Clothing

Wear close fitting clothing and safety equipment appropriate to the job.

Prolonged exposure to loud noise can cause impairment or loss of hearing.

Wear a suitable hearing protective device such as earmuffs or earplugs to protect against objectionable or uncomfortable loud noises.

Operating equipment safely requires the full attention of the operator. Do not wear radio or music headphones while operating machine.

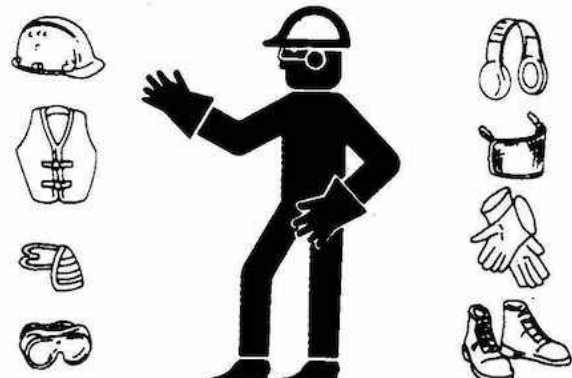

TS206-UN: Protective Clothing

DX,WEAR-19-19900910

Service Accumulator Systems Safely

Escaping fluid or gas from systems with pressurized accumulators that are used in air conditioning, hydraulic, and air brake systems can cause serious injury. Extreme heat can cause the accumulator to burst, and pressurized lines can be accidentally cut. Do not weld or use a torch near a pressurized accumulator or pressurized line.

Relieve pressure from the pressurized system before removing accumulator.

Relieve pressure from the hydraulic system before removing accumulator. Never attempt to relieve hydraulic system or accumulator pressure by loosening a fitting.

Accumulators cannot be repaired.

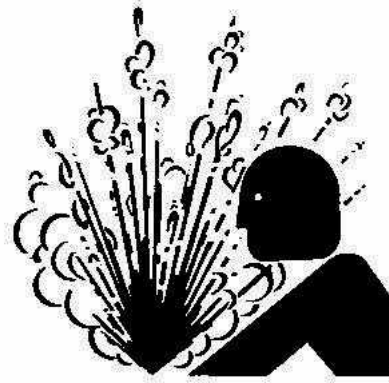

TS281-UN: Hydraulic Accumulator

DX,WW,ACCLA2-19-20030822

Handling Batteries Safely

Battery gas can explode. Keep sparks and flames away from batteries. Use a flashlight to check battery electrolyte level.

Never check battery charge by placing a metal object across the posts. Use a voltmeter or hydrometer.

Always remove grounded (-) battery clamp first and replace grounded clamp last.

Sulfuric acid in battery electrolyte is poisonous and strong enough to burn skin, eat holes in clothing, and cause blindness if splashed into eyes.

Avoid hazards by:

- Filling batteries in a well-ventilated area
- Wearing eye protection and rubber gloves
- Avoiding use of air pressure to clean batteries
- Avoiding breathing fumes when electrolyte is added
- Avoiding spilling or dripping electrolyte
- Using correct battery booster or charger procedure.

If acid is spilled on skin or in eyes:

1. Flush skin with water.
2. Apply baking soda or lime to help neutralize the acid.
3. Flush eyes with water for 15—30 minutes. Get medical attention immediately.

If acid is swallowed:

1. Do not induce vomiting.
2. Drink large amounts of water or milk, but do not exceed 2 L (2 qt.).
3. Get medical attention immediately.

WARNING: Battery posts, terminals, and related accessories contain lead and lead compounds, chemicals known to the State of California to cause cancer and reproductive harm. **Wash hands after handling.**



TS204-UN: Caution



TS203-UN: Caution

DX,WW,BATTERIES-19-20101202

Handle Agricultural Chemicals Safely

Chemicals used in agricultural applications such as fungicides, herbicides, insecticides, pesticides, rodenticides, and fertilizers can be harmful to your health or the environment if not used carefully.

Always follow all label directions for effective, safe, and legal use of agricultural chemicals.

Reduce risk of exposure and injury:

- Wear appropriate personal protective equipment as recommended by the manufacturer. In the absence of manufacturer's instructions, follow these general guidelines:
 - Chemicals labeled **'Danger'** : Most toxic. Generally require use of goggles, respirator, gloves, and skin protection.
 - Chemicals labeled **'Warning'** : Less toxic. Generally require use of goggles, gloves, and skin protections.
 - Chemicals labeled **'Caution'** : Least toxic. Generally require use of gloves and skin protection.
- Avoid inhaling vapor, aerosol or dust.
- Always have soap, water, and towel available when working with chemicals. If chemical contacts skin, hands, or face, wash immediately with soap and water. If chemical gets into eyes, flush immediately with water.
- Wash hands and face after using chemicals and before eating, drinking, smoking, or urination.
- Do not smoke or eat while applying chemicals.
- After handling chemicals, always bathe or shower and change clothes. Wash clothing before wearing again.
- Seek medical attention immediately if illness occurs during or shortly after use of chemicals.
- Keep chemicals in original containers. Do not transfer chemicals to unmarked containers or to containers used for food or drink.
- Store chemicals in a secure, locked area away from human or livestock food. Keep children away.
- Always dispose of containers properly. Triple rinse empty containers and puncture or crush containers and dispose of properly.

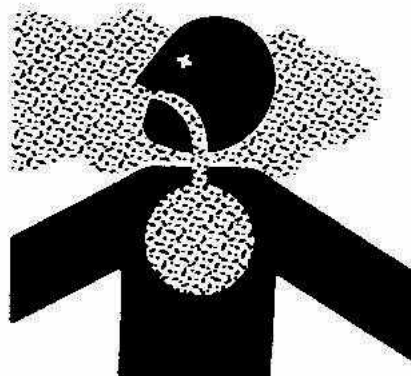

TS220-UN: Safety

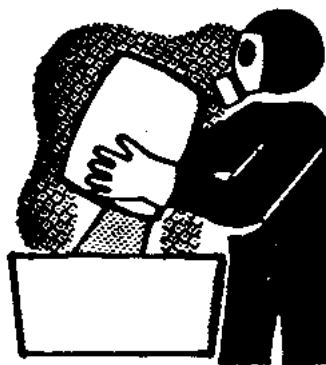

A34471

A34471-UN: Safety

DX,WW,CHEM01-19-20100824

Service Cooling System Safely

Explosive release of fluids from pressurized cooling system can cause serious burns.

Shut off engine. Only remove filler cap when cool enough to touch with bare hands. Slowly loosen cap to first stop to relieve pressure before removing completely.

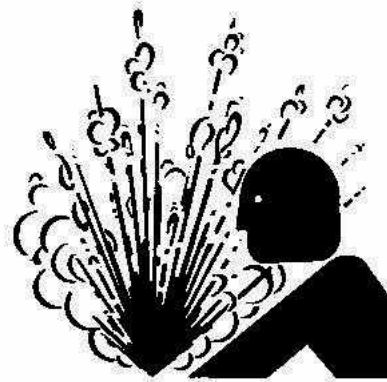

TS281-UN: Cooling System

DX,WW,COOLING-19-20090819

Use Steps and Handholds Correctly

Prevent falls by facing the machine when getting on and off. Maintain 3-point contact with steps, handholds, and handrails.

Use extra care when mud, snow, or moisture present slippery conditions. Keep steps clean and free of grease or oil. Never jump when exiting machine. Never mount or dismount a moving machine.

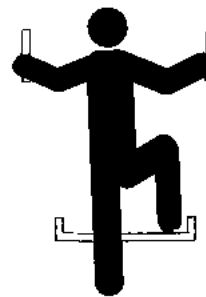

T133468-UN: Use Handholds and Steps

DX,WW,MOUNT-19-20111012

by BestManuals.com

Transport Tractor Safely

A disabled tractor is best transported on a flatbed carrier. Use chains to secure the tractor to the carrier. The axles and tractor frame are suitable attachment points.

Before transporting the tractor on a low-loader truck or flatbed rail wagon, make sure that the hood is secured over the tractor engine and that doors, roof hatch (if equipped) and windows are properly closed.

Never tow a tractor at a speed greater than 10 km/h (6 mph). An operator must steer and brake the tractor under tow.

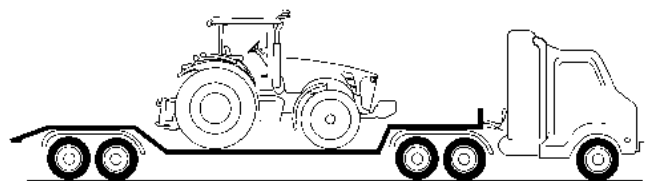

RXA0103709-UN: Transport Tractor Safely

DX,WW,TRANSPORT-19-20090819

by BestManuals.com

Deliver Safely

The best method for delivering tractors, self-propelled equipment, and most implements or attachments is on a flatbed truck or trailer. Secure loads with tie down chains, straps, and binders.

Be aware of height and width restrictions to avoid collision with overpasses, bridge abutments, or other road users. Check with local authorities regarding oversized load transport restrictions and requirements.

When towing, remember that towed loads can swerve, upset or cause loss of control when towed with an undersized towing unit.

Never tow an implement behind a truck or other motor vehicle. The ability to maintain control and brake the implement and vehicle mass is compromised. The ability to properly attach the implement hitch and safety chain to the motor vehicle may be marginal. With most motor vehicles it is not possible to properly operate the warning, tail and turn signal lights on the implement, and in most cases the implement tires are not rated for highway speeds.

Tow drawn implements only with a properly sized and weighted tractor equipped with a stationary drawbar. (See tractor operator's manual for ballast requirements.)

Integral and semi-integral implements should be attached to a tractor with a three-point hitch as specified in the implement operator's manual. The tractor should have the proper size rear tires and the sway blocks should be in the down position. Do not transport unless the tractor front end is ballasted to the weight levels specified in the tractor operator's manual for the correct implement code.

Before transporting, attach a properly sized safety tow chain between the implement and tractor.

Stopping distance increases with speed and weight of towed loads, and when transporting on slopes. Observe these recommended maximum road speeds, or local speed limits that may be lower:

- If towed equipment does not have brakes, do not transport at speeds above 32 km/h (20 mph) and do not tow loads that weigh more than 1.5 times the weight of the tractor.
- If the towed equipment has brakes, do not transport at speeds above 40 km/h (25 mph) and do not tow loads more than 4.5 times the weight of the tractor.

Use additional caution and reduce speed when towing under adverse surface conditions, when turning, and when on inclines.

Attach the implement lighting harness to the tractor and make sure that the warning and taillights on both the tractor and implement are on and functioning properly.

Make sure that the SMV and other markings on the implement are clean and visible.

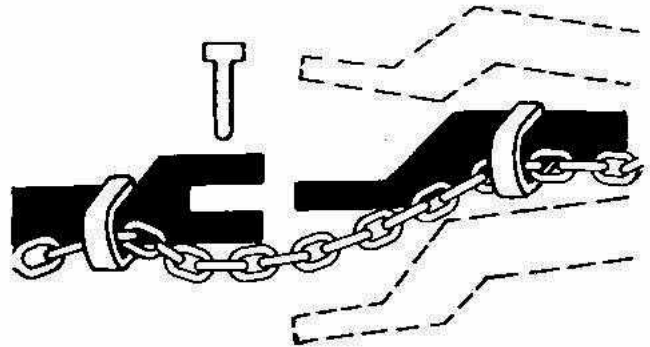

TS217-UN: Safety Chain

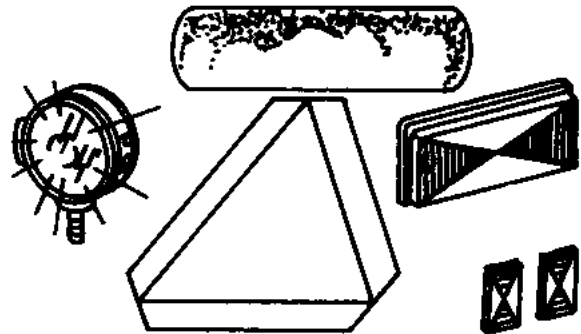

TS949-UN: Safety Lighting and Markings

Information Available in Sections, Groups and Subgroups

IMPORTANT:

Troubleshoot the equipment one problem at a time. Repairing one system problem could solve a problem in several systems.

NOTE:

If it is determined that a problem is not in a specific section (system), the diagnostic procedure references another, more appropriate section.

Each section identifies a major category or system. Sections ending in the number nine contain connector information, component identification, and location photographs for the various systems. For example, Section 249 contains electrical connector and component information and Section 279 contains hydraulic component identification and location.

Within each section, the manual is divided into groups and subgroups with blocks of information.

Groups 05 contain general information, specifications, standard symbols, or other information not associated with a specific system.

Groups 10 contain reference material utilized in diagnostic routines. Groups 10 contain the following information:

- Observable Symptoms/System Diagnostics
- Calibration Procedures
- Preliminary Checks
- Operational Checks
- Tests and Adjustments

Groups 20 contain THEORY OF OPERATION. The theory of operation gives a quick look at what the system does and more detailed information about how the system operates.

Groups 30 contain SCHEMATICS. The schematic is a graphical representation of the system, components, and layout. Each component represented on the schematic has a unique name and designator used for identifying parts in the diagnostic routine. These names could be different than the names used in conversation or in marketing literature.

Groups 50 contain DIAGNOSTIC ROUTINES. The diagnostic procedures provide detailed step-by-step instructions to help isolate failed components.

DX,TM,SEC,GRP-19-20110511

Glossary of Terms

ITEM	ABBREVIATION	DESCRIPTION
Accessory	ACC	Secondary electrical system
Air Conditioning	A/C	System used for cooling the air in the cab
Alternating Current	AC	Electrical current that reverses its direction at regularly recurring intervals
Battery	Bat	A device used to furnish electrical current
Brakes	BR	Abbreviation
Charge Air Cooler	CAC	A device used for cooling compressed intake air
Controller Area Network	CAN	A communication system linking on-board electronics
Chassis Control Unit	CCU	Computerized system for tractor monitoring
Circuit	CCT	A complete path of an electrical current
Clockwise	CW	Direction in which the hands of a clock rotate
Cold Cranking Amperes	CCA	Battery's measured capability to perform during cold-weather operation
Component Technical Manual	CTM	Technical manual developed for the servicing of major components
Counterclockwise	CCW	Direction opposite the rotation of the hands of a clock
Diagnostic Receptacle	DR	A connection where hydraulic pressure can be measured
Digital Multimeter	DMM	An electrical multi-functional measuring device
Direct Current	DC	Electrical current flowing in one direction only
Diesel Particulate Filter	DPF	Portion of the exhaust filter
Engine Control Unit	ECU	Electronic device used to house computerized system that controls engine functions
Exhaust Gas Recirculation	EGR	Engine emission
Electrohydraulic	EH	Hydraulic valve function that is controlled electrically
Electronic Components Relay	ELX	Relay powering most of the electronic components
Open Operator Station	OOS	Abbreviation
Forward	FWD	Direction of movement
Forward-Neutral-Reverse	FNR	Abbreviation
Gallons per Minute	gpm	Amount of fluid displaced over a period of one minute
Heating, Ventilating, and Air Conditioning	HVAC	Abbreviation
High-Pressure Common Rail	HPCR	Abbreviation
Hitch Control Unit	HCU	Computerized system used to control hitch functions
Housing	Hsg	Abbreviation
Hydrostatic Transmission	HST	Computerized system used to control hydrostatic transmission functions
Hydraulic Trailer Brake	HTB	Abbreviation
Ignition	IGN	Control for starting and stopping the tractor
Inside Diameter	ID	Abbreviation
Instrument Cluster Control Unit	ICC	Computerized system used to control instrument cluster functions
International Standards Organization	ISO	Standards organization
Joint Industry Council Organization	JIC	Standards organization
Left-Hand	LH or L-H	Abbreviation
Liquid Crystal Display	LCD	A technology used for displaying information
Manifold Air Pressure	MAP	Air Pressure measured at engine air intake
Mechanical	Mech or MECH	Abbreviation
Mechanical Front Wheel Drive	MFWD	A mechanically powered front axle
Negative	Neg (—)	Electrical Ground Circuit
Number	No.	Abbreviation
Nitrogen Oxide	NOx	Engine emission
O-ring Face Seal	ORFS or ORS	A type of seal used in hydraulic connections
Outside Diameter	OD	Abbreviation
Open Operator Station	OOS	Abbreviation
Performance Monitor	Perf Mon or PrF	Abbreviation
Positive	Pos (+)	Charged part of an electrical circuit
Potentiometer	POT	A device used to vary electrical voltage
Power Take-Off	PTO	Abbreviation
Power Train Reverser	PTR	Computerized system used to control power reverse transmission functions
Pressure Control Valve	PCV	Valve used to control pressure within a system
Pressure Regulating Valve	PRV	A device used to regulate pressure in a system
Product Identification Number	PIN	Serial number relating to tractor identification
Pulse-Width-Modulation	PWM	Method of controlling electrical signals
Reverse	Rev	Direction of movement
Revolutions per Minute	rpm	Abbreviation
Right-Hand	RH or R-H	Abbreviation
Rockshaft	RS	Abbreviation
Roll-Over Protective Structure	ROPS	Abbreviation
Selective Control Valve	SCV	Device used to control remote hydraulic functions
Slow Moving Vehicle	SMV	Warning sign on the rear of the tractor
Society of Automotive Engineers	SAE	Engineering Standards Organization
Specification	Spec	Abbreviation
Switch	SW	Abbreviation

ITEM	ABBREVIATION	DESCRIPTION
Tachometer	Tach	Abbreviation
Tail Light	TL	Abbreviation
Temperature	Temp	Abbreviation
Three-Point Hitch	3PT	Abbreviation
Transmission	Trans	Abbreviation
Transient Voltage Protection	TVP	An electrical device used to protect a circuit from voltage surge
User Interface Module	UIM	Abbreviation
Voltage (Volts)	V	Abbreviation
Voltage Detector	V Det	Abbreviation
Warning Lamp	WL	Abbreviation
Without	W/O	Abbreviation
Wide-Open Throttle	WOT	Full throttle
Two-Wheel Drive	2WD	Vehicle where only one pair of wheels is powered

WS68074,00007B1-19-20150818

Trademarks

	Trademarks
AMP®	Trademark of Tyco Electronics
AutoTrac™	Trademark of Deere & Company
Bio Hy-Gard™	Trademark of Deere & Company
BIO-GREASE-GARD™	Trademark of Deere & Company
Break-In Plus™	Trademark of Deere & Company
Break-In™	Trademark of Deere & Company
CINCH®	Trademark of Cinch Inc.
COOL-GARD™	Trademark of Deere & Company
COOLSCAN PLUS™	Trademark of Deere & Company
CoolScan™	Trademark of Deere & Company
Custom Performance™	Trademark of Deere & Company
Deere™	Trademark of Deere & Company
DEUTSCH®	Trademark of Deutsch Co.
Hy-Gard™	Trademark of Deere & Company
John Deere™	Trademark of Deere & Company
Loctite®	Trademark of Henkel Corporation
Metri-Pack®	Trademark of Delphi Connection Systems
PowrReverser™	Trademark of Deere & Company
Roll-Gard™	Trademark of Deere & Company
Service ADVISOR™	Trademark of Deere & Company
SERVICEGARD™	Trademark of Deere & Company
TEFLON®	Trademark of DuPont Co.
WEATHER PACK®	Trademark of Packard Electric
TractorPlus™	Trademark of Deere & Company

PP71895,000165D-19-20201204

by Best-Manuals.com

by BestManuals.com

Unified Inch Bolt and Screw Torque Values

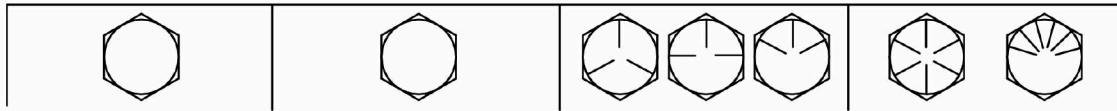

TS1671-UN: Unified Inch Bolt and Screw

Bolt or Screw Size	SAE Grade 1 [Grade 1 applies for hex cap screws over 6 in (152 mm) long, and for all other types of bolts and screws of any length.]				SAE Grade 2 [Grade 2 applies for hex cap screws (not hex bolts) up to 6 in (152 mm) long.]				SAE Grade 5, 5.1 or 5.2				SAE Grade 8 or 8.2			
	Hex Head [Hex head column values are valid for ISO 4014 and ISO 4017 hex head, ISO 4162 hex socket head, and ISO 4032 hex nuts.]		Flange Head [Hex flange column values are valid for ASME B18.2.3.9M, ISO 4161, or EN 1665 hex flange products.]		Hex Head [Hex head column values are valid for ISO 4014 and ISO 4017 hex head, ISO 4162 hex socket head, and ISO 4032 hex nuts.]		Flange Head [Hex flange column values are valid for ASME B18.2.3.9M, ISO 4161, or EN 1665 hex flange products.]		Hex Head [Hex head column values are valid for ISO 4014 and ISO 4017 hex head, ISO 4162 hex socket head, and ISO 4032 hex nuts.]		Flange Head [Hex flange column values are valid for ASME B18.2.3.9M, ISO 4161, or EN 1665 hex flange products.]		Hex Head [Hex head column values are valid for ISO 4014 and ISO 4017 hex head, ISO 4162 hex socket head, and ISO 4032 hex nuts.]		Flange Head [Hex flange column values are valid for ASME B18.2.3.9M, ISO 4161, or EN 1665 hex flange products.]	
	N·m	lb·in	N·m	lb·in	N·m	lb·in	N·m	lb·in	N·m	lb·in	N·m	lb·in	N·m	lb·in	N·m	lb·in
1/4	3.1	27.3	3.2	28.4	5.1	45.5	5.3	47.3	7.9	70.2	8.3	73.1	11.2	99.2	11.6	103
5/16	6.1	54.1	6.5	57.7	10.2	90.2	10.9	96.2	15.7	139	16.8	149	22.2	16.4	23.7	17.5
3/8	10.5	93.6	11.5	102	17.6	156	19.2	170	27.3	20.1	29.7	21.9	38.5	28.4	41.9	30.9
7/16	16.7	148	18.4	163	27.8	20.5	30.6	22.6	43	31.7	47.3	34.9	60.6	44.7	66.8	49.3
1/2	25.9	19.1	28.2	20.8	43.1	31.8	47	34.7	66.6	49.1	72.8	53.7	94	69.3	103	75.8
9/16	36.7	27.1	40.5	29.9	61.1	45.1	67.5	49.8	94.6	69.8	104	77	134	98.5	148	109
5/8	51	37.6	55.9	41.2	85	62.7	93.1	68.7	131	96.9	144	106	186	137	203	150
3/4	89.5	66	98	72.3	149	110	164	121	230	170	252	186	325	240	357	263
7/8	144	106	157	116	144	106	157	116	370	273	405	299	522	385	572	422
1	216	159	236	174	216	159	236	174	556	410	609	449	785	579	860	634
1-1/8	305	225	335	247	305	225	335	247	685	505	751	554	1110	819	1218	898
1-1/4	427	315	469	346	427	315	469	346	957	706	1051	775	1552	1145	1703	1256
1-3/8	564	416	618	456	564	416	618	456	1264	932	1386	1022	2050	1512	2248	1658
1-1/2	743	548	815	601	743	548	815	601	1665	1228	1826	1347	2699	1991	2962	2185

The nominal torque values listed are for general use only with the assumed wrenching accuracy of 20%, such as a manual torque wrench.

Replace fasteners with the same or higher property class. If higher property class fasteners are used, tighten these to the strength of the original.

DO NOT use these values if a different torque value or tightening procedure is given for a specific application.

For lock nuts, for stainless steel fasteners, or for nuts on U-bolts, see the tightening instructions for the specific application.

- Make sure that fastener threads are clean.
- Apply a thin coat of Hy-Gard™ or equivalent oil under the head and on the threads of the fastener, as shown in the following image.
- Be conservative with the amount of oil to reduce the potential for hydraulic lockup in blind holes due to excessive oil.
- Properly start thread engagement.

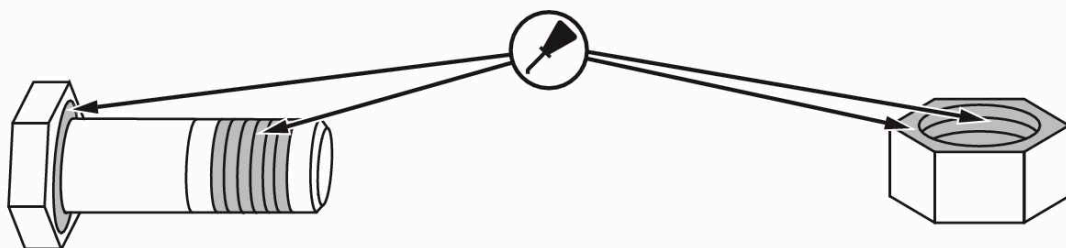

TS1741-UN: Lubricant Locations

Metric Bolt and Screw Torque Values

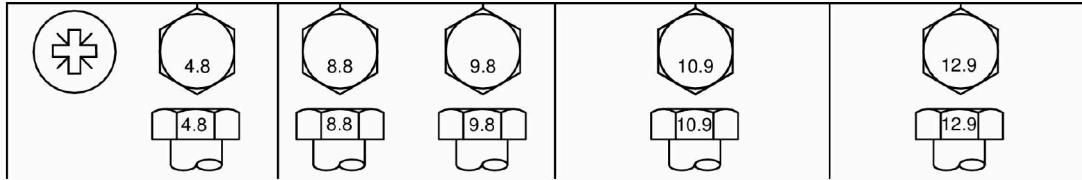

TS1742-UN: Metric Bolt and Screw

Bolt or Screw Size	Class 4.8				Class 8.8 or 9.8				Class 10.9				Class 12.9			
	Hex Head [Hex head column values are valid for ISO 4014 and ISO 4017 hex head, ISO 4162 hex socket head, and ISO 4032 hex nuts.]		Flange Head [Hex flange column values are valid for ASME B18.2.3.9M, ISO 4161, or EN 1665 hex flange products.]		Hex Head [Hex head column values are valid for ISO 4014 and ISO 4017 hex head, ISO 4162 hex socket head, and ISO 4032 hex nuts.]		Flange Head [Hex flange column values are valid for ASME B18.2.3.9M, ISO 4161, or EN 1665 hex flange products.]		Hex Head [Hex head column values are valid for ISO 4014 and ISO 4017 hex head, ISO 4162 hex socket head, and ISO 4032 hex nuts.]		Flange Head [Hex flange column values are valid for ASME B18.2.3.9M, ISO 4161, or EN 1665 hex flange products.]		Hex Head [Hex head column values are valid for ISO 4014 and ISO 4017 hex head, ISO 4162 hex socket head, and ISO 4032 hex nuts.]		Flange Head [Hex flange column values are valid for ASME B18.2.3.9M, ISO 4161, or EN 1665 hex flange products.]	
	N·m	lb·in	N·m	lb·in	N·m	lb·in	N·m	lb·in	N·m	lb·in	N·m	lb·in	N·m	lb·in	N·m	lb·in
M6	3.6	31.9	3.9	34.5	6.7	59.3	7.3	64.6	9.8	86.7	10.8	95.6	11.5	102	12.6	112
M8	8.6	76.1	9.4	83.2	16.2	143	17.6	156	23.8	17.6	25.9	19.1	27.8	20.5	30.3	22.3
M10	16.9	150	18.4	13.6	31.9	23.5	34.7	25.6	46.8	34.5	51	37.6	55	40.6	60	44.3
M12	—	—	—	—	55	40.6	61	45	81	59.7	89	65.6	95	70.1	105	77.4
M14	—	—	—	—	87	64.2	96	70.8	128	94.4	141	104	150	111	165	122
M16	—	—	—	—	135	99.6	149	110	198	146	219	162	232	171	257	190
M18	—	—	—	—	193	142	214	158	275	203	304	224	322	245	356	263
M20	—	—	—	—	272	201	301	222	387	285	428	316	453	334	501	370
M22	—	—	—	—	365	263	405	299	520	384	576	425	608	448	674	497
M24	—	—	—	—	468	345	518	382	666	491	738	544	780	575	864	637
M27	—	—	—	—	683	504	758	559	973	718	1080	797	1139	840	1263	932
M30	—	—	—	—	932	687	1029	759	1327	979	1466	1081	1553	1145	1715	1265
M33	—	—	—	—	1258	928	1398	1031	1788	1319	1986	1465	2092	1543	2324	1714
M36	—	—	—	—	1617	1193	1789	1319	2303	1699	2548	1879	2695	1988	2982	2199

The nominal torque values listed are for general use only with the assumed wrenching accuracy of 20%, such as a manual torque wrench.

Replace fasteners with the same or higher property class. If higher property class fasteners are used, tighten these to the strength of the original.

DO NOT use these values if a different torque value or tightening procedure is given for a specific application.

For lock nuts, for stainless steel fasteners, or for nuts on U-bolts, see the tightening instructions for the specific application.

- Make sure that fastener threads are clean.
- Apply a thin coat of Hy-Gard™ or equivalent oil under the head and on the threads of the fastener, as shown in the following image.
- Be conservative with the amount of oil to reduce the potential for hydraulic lockup in blind holes due to excessive oil.
- Properly start thread engagement.

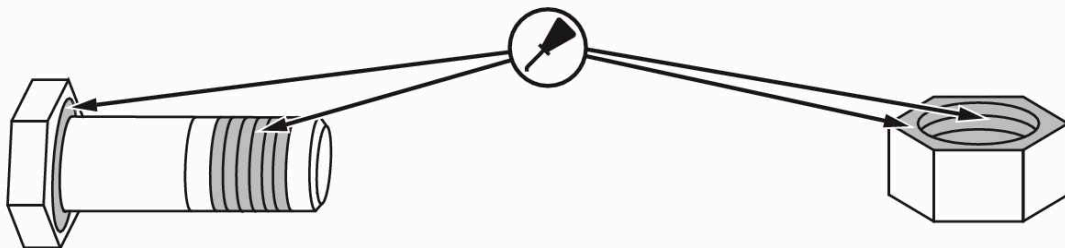

TS1741-UN: Lubricant Locations

DX,TORQ2-19-20220509

Metric Cap Screw Torque Values—Grade 7

NOTE:

When bolting aluminum parts, tighten to 80% of torque specified in table.

Size	N·m	(lb-ft)
M6	9.5—12.2	(7—9)
M8	20.3—27.1	(15—20)
M10	47.5—54.2	(35—40)
M12	81.4—94.9	(60—70)
M14	128.8—146.4	(95—108)
M16	210.2—240	(155—177)

CED,OUO1085,12-19-20000731

Gasket Sealant Application

Cleaning— Clean both surfaces that will be joined using 100% isopropyl alcohol. Wipe excess off with a clean cloth. Cleaner/degreaser can be substituted for isopropyl alcohol.

How to Dispense, Apply, and Assemble Gasket Sealants— Dispense approximately 1 to 2 oz. of flexible form-in-place gasket on a clean sheet or table top. Avoid using excess amounts that may be exposed for long periods of time. This will help prevent contamination from surrounding atmosphere such as dust with metal content.

Using an ink roller or similar device, apply to one surface of the joint by loading the roller from a plastic sheet and transferring the material in a thin film to the joint. The application should be the thinnest film possible, but providing complete coverage. This can be judged by the appearance of the joint once it is put together. Excessive amounts of material will cause incorrect bearing end play, extend cure time, and will cause runoff of the material. A small bead or buildup at the joint is permissible and indicates good dispersion through the joint. Excess can be wiped from the joint. Joining should take place within three minutes after sealant application.

Apply proper cap screw torque and sequence as applicable. Allow a minimum of 30 minutes before air test or adding oil for test stand usage.

Disassembly— Cured material can be removed with a wire brush or scraper. Chemical cleaners are available for use, should they be deemed necessary.

AA95137,00023E5-19-20110531

Service Recommendations for O-Ring Boss Fittings

Straight Fitting

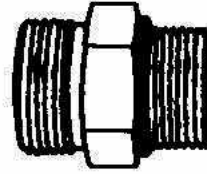

T6243AE-UN: Straight Fitting

1. Inspect O-ring boss seat for dirt or defects.
2. Lubricate O-ring with petroleum jelly. Place electrical tape over threads to protect O-ring. Slide O-ring over tape and into O-ring groove of fitting. Remove tape.
3. Tighten fitting to torque value shown on chart.

Angle Fitting

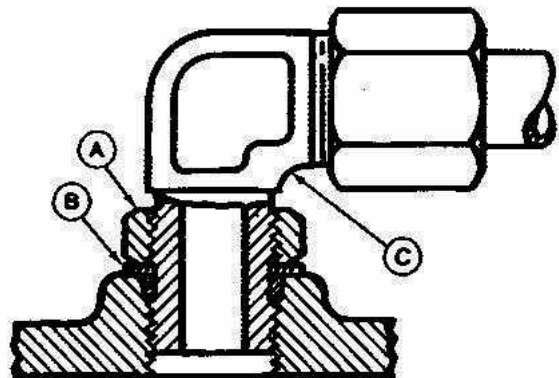

T6520AB-UN: Angle Fitting

A - Lock Nut
B - Backup Washer

C - Head End

1. Back off lock nut (A) and backup washer (B) completely to head end (C) of fitting.
2. Turn fitting into threaded boss until backup washer contacts face of boss.
3. Turn fitting head end counterclockwise to proper index (maximum of one turn).
4. **NOTE:**

Do not allow hoses to twist when tightening fittings.

Hold fitting head end with a wrench and tighten locknut and backup washer to proper torque value.

STRAIGHT FITTING OR SPECIAL NUT TORQUE CHART

Thread Size	N·m	lb·ft
3/8-24 UNF	8	6
7/16-20 UNF	12	9
1/2-20 UNF	16	12
9/16-18 UNF	24	18
3/4-16 UNF	46	34
7/8-14 UNF	62	46
1-1/16-12 UN	102	75
1-3/16-12 UN	122	90
1-5/16-12 UN	142	105
1-5/8-12 UN	190	140

STRAIGHT FITTING OR SPECIAL NUT TORQUE CHART

1-7/8-12 UN

N·m
217

lb·ft
160

NOTE:

Torque tolerance is ± 10%.

04T,90,K66-19-19990929

Service Recommendations for Flat Face O-Ring Seal Fittings

1. Inspect the fitting sealing surfaces and O-ring. They must be free of dirt or defects.
2. Lubricate O-rings and install into groove using petroleum jelly to hold in place.
3. Index angle fittings and tighten by hand, pressing joint together to ensure O-ring remains in place.
4. Tighten fitting or nut to torque value shown on the chart. Do not allow hoses to twist when tightening fittings; use back-up wrench on straight hose couplings.

IMPORTANT:

Tighten fittings to 150% of listed torque value if indexing is necessary or if fitting is attached to an actuating device.

Tighten fittings to 50% of listed torque value if used in aluminum housing.

FLAT FACE O-RING SEAL FITTING TORQUE*

Nomial Tube OD		Thread Size	Swivel Nut		Bulkhead Nut	
mm	in.	in.	N·m	lb.-ft.	N·m	lb.-ft.
6.35	0.250	9/16-18	16	12	12	9
9.52	0.375	11/16-16	24	18	24	18
12.70	0.500	13/16-16	50	37	46	34
15.88	0.625	1-14	69	51	62	46
19.05	0.750	1-3/16-12	102	75	102	75
22.22	0.875	1-3/16-12	102	75	102	75
25.40	1.000	1-7/16-12	142	105	142	105
31.75	1.250	1-11/16-12	190	140	190	140
38.10	1.500	2-12	217	160	217	160

*Torque tolerance is +15 -20% unless otherwise specified.

Stud End O-Ring Seal Torque for Straight and Adjustable Fittings*

Thread Size	Straight Hex Size	Lock Nut Hex Size	Straight Fitting or Lock Nut Toque	
Inch	Inch	Inch	N·m	lb.-ft.
3/8-24	5/8	9/16	12	9
7/16-20	5/8	5/8	21	15
1/2-20	3/4	11/16	26	19
9/16-18	3/4	3/4	34	25
3/4-16	7/8	15/16	73	55
7/8-14	1-1/16	1-1/16	104	76
1-1/16-12	1-1/4	1-3/8	176	130
1-3/16-12	1-3/8	1-1/2	230	170
1-5/16-12	1-1/2	1-5/8	285	210

*Torque tolerance is +15 -20% unless otherwise specified.

AP43109,00003C0-19-20130621

by Best-Manuals.com

by BestManuals.com

Diesel Fuel

Use the proper diesel fuel to help prevent decreased engine performance and increased exhaust emissions. Failure to follow the fuel requirements listed below can void your engine warranty.

Consult your local fuel distributor for properties of the diesel fuel in your area.

In general, diesel fuels are blended to satisfy the low temperature requirements of the geographical area in which they are marketed.

Diesel fuels specified to ISO EN 590 or ASTM D975 are recommended.

Required fuel properties

In all cases, the fuel shall meet the following properties:

Cetane number of 45 minimum. Cetane number greater than 50 is preferred, especially when temperatures are below -20°C (-4°F) or elevations above 1500 m (5000 ft).

Cold Filter Plugging Point (CFPP) should be at least 5°C (9°F) below the expected lowest temperature or **Cloud Point** below the lowest ambient temperature.

Fuel lubricity should comply with ISO EN 590 or ASTM D975.

IMPORTANT:

Avoid damage! Improper fuel additive usage may cause damage on fuel injection equipment of diesel engines.

If a fuel of low or unknown lubricity is used, addition of John Deere PREMIUM DIESEL FUEL CONDITIONER at the specified concentration is recommended.

Sulfur content

- Diesel fuel quality and fuel sulfur content must comply with all existing emissions regulations for the area in which the engine operates.
- Use only ultra low sulfur diesel (ULSD) fuel with a maximum of 0.0015% (15mg/kg) sulfur content.

IMPORTANT:

Avoid injury! Do not mix diesel engine oil or any other type of lubricating oil with diesel fuel.

Using Bio-Diesel Fuel

Bio-diesel fuels may be used only if the bio-diesel fuel properties meet the latest edition of ASTM D6751, ASTM D7467, EN14214, or equivalent specification.

The current maximum allowable bio-diesel concentration is a 5% blend (also known as B5) in petroleum diesel fuel.

Concentrations up to B20 can be used ONLY if the biodiesel (100% biodiesel or B100) meets ASTM D6751, EN14214, or equivalent specification.

Biodiesel concentrations above B20 can harm the engine's emission control systems and should not be used. Risks, include, but are not limited to, more frequent stationary regeneration, soot accumulation, and increased intervals for ash removal.

John Deere approved fuel conditioners, which contain detergent and dispersant additives, are required when using B20, and are recommended when using lower biodiesel blends.

Handling and Storing Diesel Fuel



Avoid injury! Handle fuel carefully. Do not fill the fuel tank when engine is running.

Do not smoke while you fill the fuel tank or service the fuel system.

IMPORTANT:

Avoid damage! Do not use galvanized containers—diesel fuel stored in galvanized containers reacts with zinc coating in the container to form zinc flakes. If fuel contains water, a zinc gel will also form. The gel and flakes will quickly plug fuel filters and damage fuel injectors and fuel pumps.

- Fill the fuel tank at the end of each day's operation to prevent water condensation and freezing during cold weather.
- When fuel is stored for an extended period or if there is a slow turnover of fuel, add a fuel conditioner to stabilize the fuel and to prevent water condensation. Contact your fuel supplier for recommendations.

KN52281,1004D0F-19-20140422

Handling and Storing Diesel Fuel



Reduce the risk of fire. Handle fuel carefully. DO NOT fill the fuel tank when engine is running. DO NOT smoke while you fill the fuel tank or service the fuel system.

Fill the fuel tank at the end of each day's operation to prevent water condensation and freezing during cold weather.

Keep all storage tanks as full as practical to minimize condensation.

Ensure that all fuel tank caps and covers are installed properly to prevent moisture from entering. Monitor water content of the fuel regularly.

When using biodiesel fuel, the fuel filter may require more frequent replacement due to premature plugging.

Check engine oil level daily prior to starting engine. A rising oil level may indicate fuel dilution of the engine oil.

IMPORTANT:

The fuel tank is vented through the filler cap. If a new filler cap is required, always replace it with an original vented cap.

When fuel is stored for an extended period or if there is a slow turnover of fuel, add a fuel conditioner to stabilize the fuel. Keeping the free water drained and treating the bulk fuel storage tank quarterly with a maintenance dose of a biocide will prevent microbial growth. Contact your fuel supplier or John Deere dealer for recommendations.

DX,FUEL4-19-20180113

Engine Oil

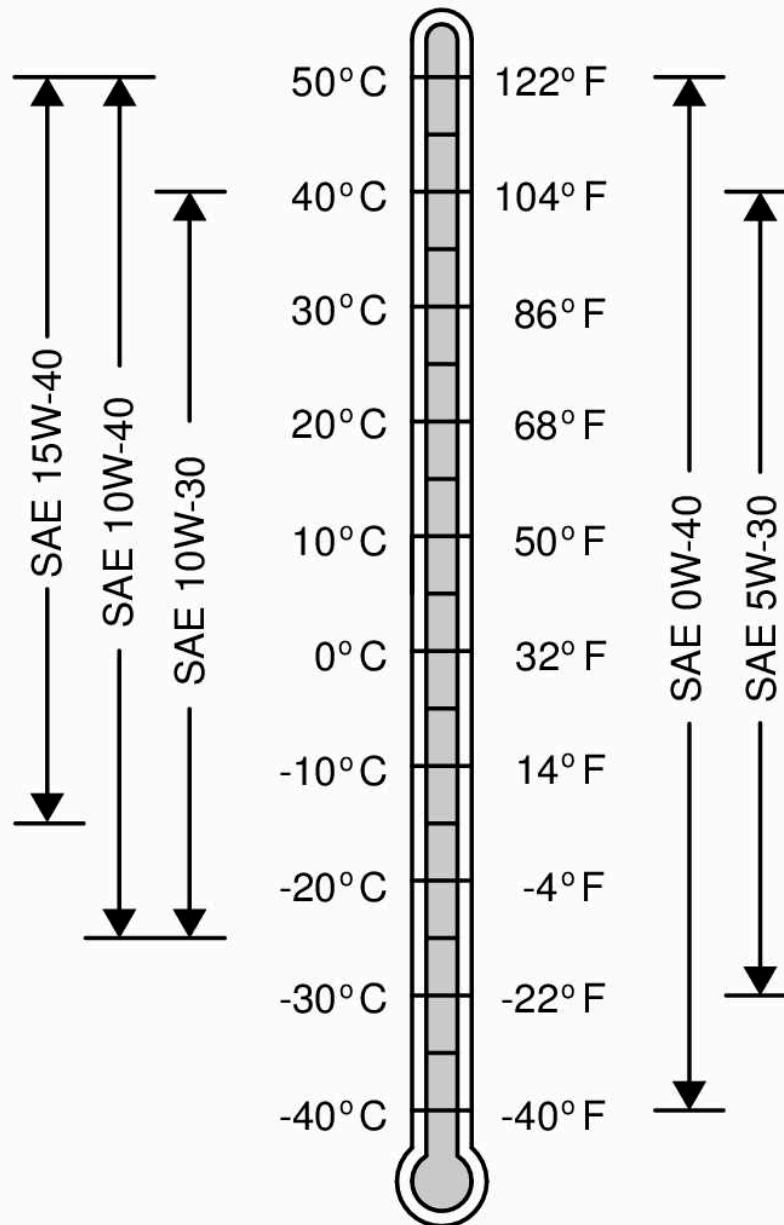

TS1691-UN: Oil Viscosities for Air Temperature Ranges

Use oil viscosity based on the expected air temperature range during the period between oil changes.

The following John Deere oils are preferred:

- John Deere Plus-50™ II
- John Deere Torq-Gard™ Supreme

Other oils may be used if John Deere oils are not available, provided they meet one of the following specifications:

- API Service Classification CJ-4, or CK-4
- JASO Specification DH-2
- ACEA Specification E6 or E9

Diesel fuel quality and fuel sulfur content must comply with all existing emissions regulations for the area in which the engine operates.

Plus-50 is a trademark of Deere & Company
Torq-Gard is a trademark of Deere & Company

UP00731,1004800-19-20170112

Engine Oil

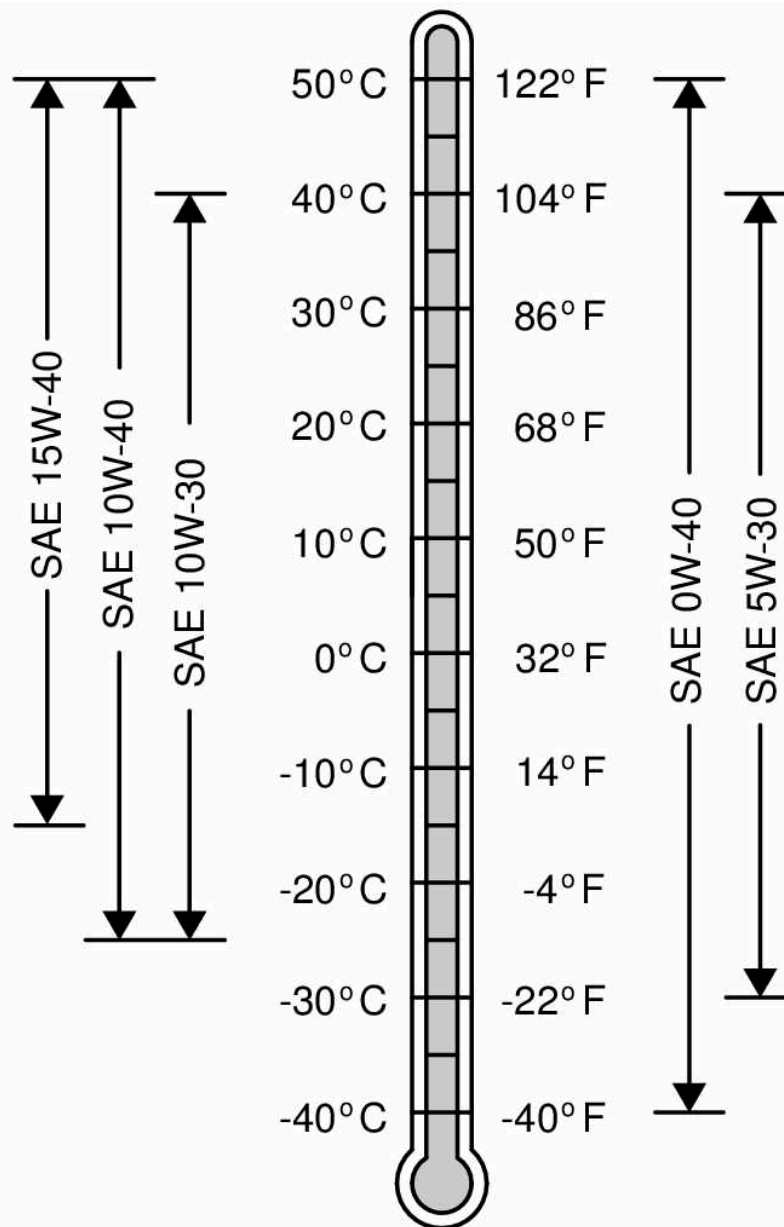

TS1691-UN: Oil Viscosities for Air Temperature Ranges

Use oil viscosity based on the expected air temperature range during the period between oil changes.

The following John Deere oils are preferred:

- John Deere Plus-50™ II
- John Deere Torq-Gard™ Supreme

Other oils may be used if John Deere oils are not available, provided they meet one of the following specifications:

- API Service Classification CJ-4, or CK-4
- JASO Specification DH-2
- ACEA Specification E6 or E9

Diesel fuel quality and fuel sulfur content must comply with all existing emissions regulations for the area in which the engine operates.

Plus-50 is a trademark of Deere & Company
Torq-Gard is a trademark of Deere & Company

UP00731,1004800-19-20170112

Alternative and Synthetic Lubricants

Conditions in certain geographical areas may require lubricant recommendations different from those printed in this manual.

Some John Deere brand coolants and lubricants may not be available in your location.

Consult your John Deere dealer to obtain information and recommendations.

Synthetic lubricants may be used if they meet the performance requirements as shown in this manual.

The temperature limits and service intervals shown in this manual apply to John Deere branded fluids or fluids that have been tested and/or approved for use in John Deere equipment.

Re-refined base stock products may be used if the finished lubricant meets the performance requirements.

DX,ALTER-19-20180113

Lubricant Storage

Your equipment can operate at top efficiency only when clean lubricants are used.

Use clean containers to handle all lubricants.

Store lubricants and containers in an area protected from dust, moisture, and other contamination. Store containers on their side to avoid water and dirt accumulation.

Make certain that all containers are properly marked to identify their contents.

Properly dispose of all old containers and any residual lubricant they may contain.

DX,LUBST-19-20110411

Mixing of Lubricants

In general, avoid mixing different brands or types of oil. Oil manufacturers blend additives in their oils to meet certain specifications and performance requirements.

Mixing different oils can interfere with the proper functioning of these additives and degrade lubricant performance.

Consult your John Deere dealer to obtain specific information and recommendations.

DX,LUBMIX-19-19960318

Multipurpose Extreme Pressure (EP) Grease

IMPORTANT:

For automated lubrication systems different ambient air temperatures need to be considered.

Use grease based on NLGI consistency numbers and the expected air temperature range during the service interval.

John Deere SD Polyurea Grease is preferred.

The following greases are also recommended:

- John Deere HD Lithium Complex Grease
- John Deere Grease-Gard™ Premium Plus

Other greases may be used if they meet the following:

- NLGI Performance Complex, Non-Classification GC-LB Synthetic Base Oil (100
- ISO-L-X-BDHB 2 or to 220 mm²/s @ 40°C)
- DIN KP 2 N-10 Lithium

IMPORTANT:

Some types of thickeners, base oils, and additives used in greases are not compatible with others. Mixing greases should be avoided. Consult your grease supplier before mixing different types of grease.

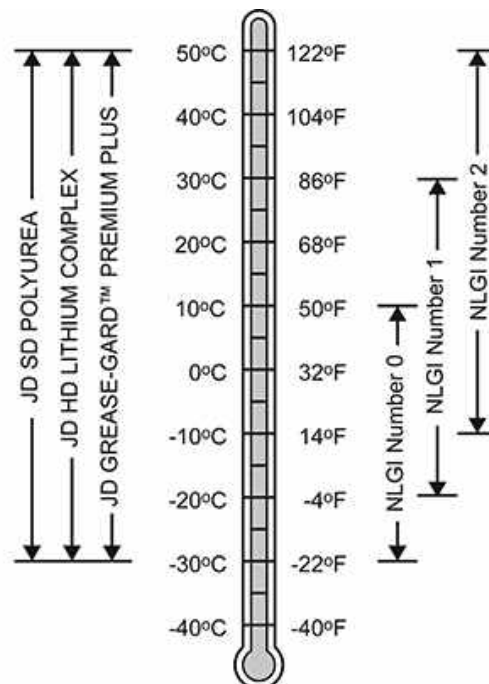

RG30199-UN: Greases for Air Temperature Ranges

Grease-Gard is a trademark of Deere & Company

DX,GREA1-19-20180113

Transmission and Hydraulic Oil

Use oil viscosity based on the expected air temperature range during the period between oil changes.

The following oils are preferred:

- John Deere HY-GARD™
- John Deere Low Viscosity HY-GARD™

Other oils may be used if they meet one of the following:

- John Deere Standard JDM J20C
- John Deere Standard JDM J20D

Use the following oil when a biodegradable fluid is required:

- John Deere [meets or exceeds the minimum biodegradability of 80% within 21 days according to CEC-L-33-T-82 test method. BIO-HY-GARD should not be mixed with mineral oils because this reduces the biodegradability and makes proper oil recycling impossible.] BIO-HY-GARD™

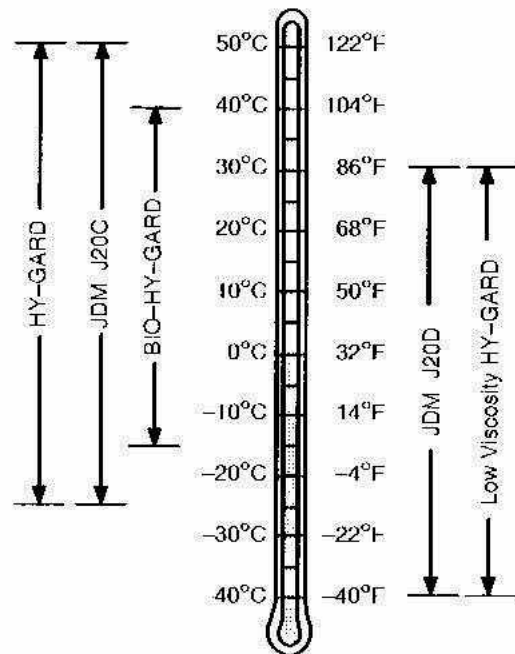

TS1651-UN: Transmission and Hydraulic Oil

HY-GARD is a trademark of Deere & Company
BIO-HY-GARD is a trademark of Deere & Company

DX,ANTI1-19-20021202

by BestManuals.com

Diesel Engine Coolant

Preferred coolants:

The following pre-mix engine coolants are preferred:

- John Deere Cool-Gard™ II
- John Deere Cool-Gard™ II PG

Not all Cool-Gard™ II pre-mix products are available in all countries.

Use Cool-Gard™ II PG when a non-toxic coolant formulation is required.

Additional Recommended Coolants

The following engine coolant is also recommended:

- John Deere Cool-Gard™ II Concentrate in a 40—60% mixture of concentrate with quality water.

IMPORTANT:

Avoid damage! When mixing coolant concentrate with water, do not use less than 40% or greater than 60% concentration of coolant. Less than 40% gives inadequate additives for corrosion protection. Greater than 60% can result in coolant gelation and cooling system problems.

Other Coolants

Other ethylene glycol or propylene glycol base coolants may be used if they meet one of the following specifications:

- Pre-mix coolant meeting ASTM D6210 requirements
- Coolant concentrates meeting ASTM D6210 requirements in a 40% to 60% mixture of concentrate with quality water
- Pre-mix coolant meeting ASTM D3306 requirements
- Coolant concentrates meeting ASTM D3306 requirements in a 40% to 60% mixture of concentrate with quality water

If coolant meeting one of these specifications is unavailable, use a coolant concentrate or pre-mix coolant that has a minimum of the following chemical and physical properties:

- Is formulated with a quality nitrite-free additive package.
- Protects the cooling system metals (cast iron, aluminum alloys, and copper alloys such as brass) from corrosion.

Water Quality

Water quality is important to the performance of the cooling system. Distilled, deionized, or demineralized water is recommended for mixing with ethylene glycol base engine coolant concentrate.

Coolant Drain Intervals

Drain and flush the cooling system and refill with fresh coolant at the indicated interval, which varies with the coolant used.

When Cool-Gard™ II or Cool-Gard™ II PG is used, the drain interval is 6 years or 6000 operating hours.

If a coolant other than Cool-Gard™ II or Cool-Gard™ II PG is used, reduce the drain interval to 2 years or 2000 operating hours.

IMPORTANT:

Avoid Damage!

- Do not use cooling system sealing additives or antifreeze that contains sealing additives.
- Do not mix ethylene glycol and propylene glycol base coolants.
- Do not use coolants that contain nitrites.

Cool-Gard is a trademark of Deere & Company

UP00731,0000022-19-20190117

by Best-Manuals.com

by BestManuals.com

Group 05E - Serial Number Locations

Serial Numbers

When ordering parts or submitting a warranty claim, it is IMPORTANT that the machine product identification number (PIN) and component serial numbers are included. The location of the PIN, engine, and turbocharger serial numbers are shown.

KN52281,1004A90-19-20131025

Machine Product Identification Number

The machine's product identification number plate (A) is located on the right side of the machine.

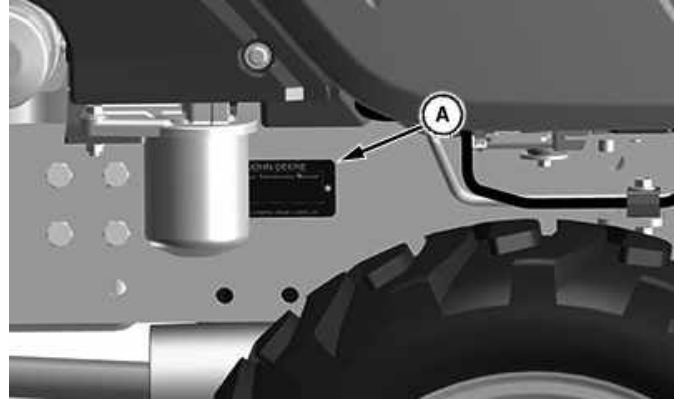

LV25641-UN: Machine PIN

A - Product Identification Number Plate

WS68074,00019D0-19-20161011

Engine Serial Number

The engine serial number plate (B) is located on engine valve cover.

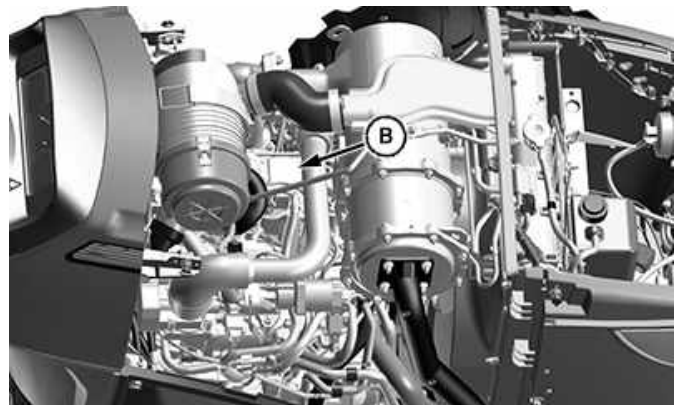

LV25640-UN: Engine Serial Number

B - Engine Serial Number

WS68074,00019D1-19-20161011

Transmission Serial Number

The Transmission Serial Number is marked on left side of the transmission on clutch housing as shown in figure

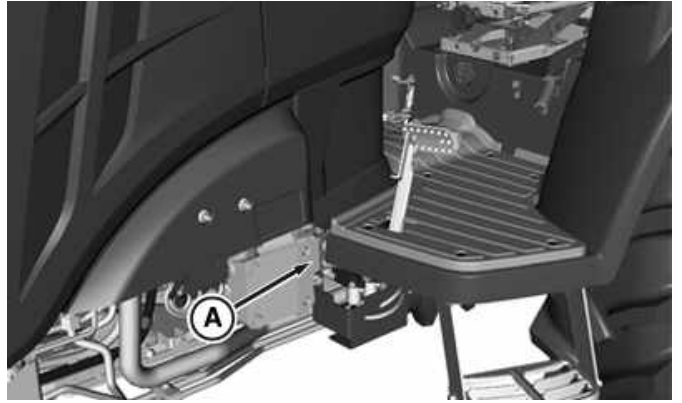

PY19452-UN: Transmission Serial Number

**A - Transmission Serial
Number**

BS13987,000043E-19-20140404

by Best-Manuals.com

Contents

Group 05 - Engine

Group 10 - Cooling System

Radiator Removal and Installation (—MY22)

Radiator Removal and Installation (MY23—)

Engine Removal and Installation

Required Tool:

- JT07335 Splitting Stands

Remove:

1. Park machine safely and allow engine to cool.
2. Open and remove hood, side panels, and lower side panels.
3. Disconnect negative and then positive battery cables.
4. Drain coolant from radiator.
5. Drain fuel from the fuel tank.
6. Remove upper radiator hose (A) and lower radiator hose (B). Plug openings to prevent dirt from getting in radiator and engine.

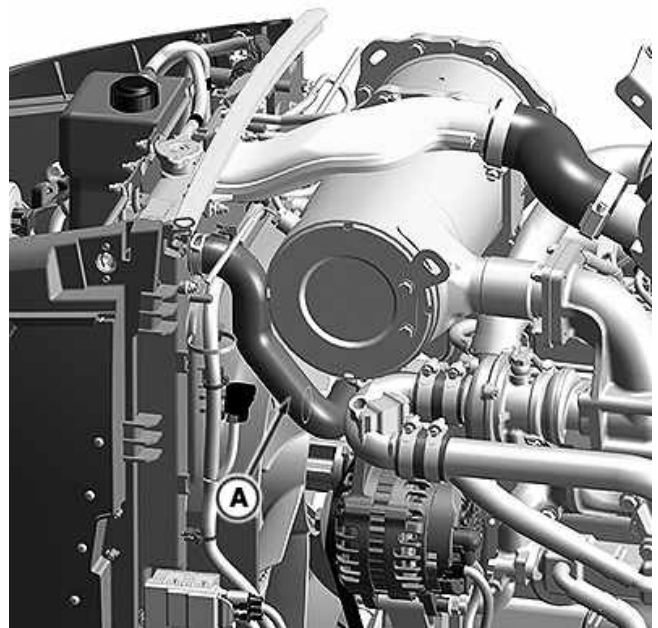

LV25947-UN: Upper Radiator Hose (2038R shown; 2032R similar)

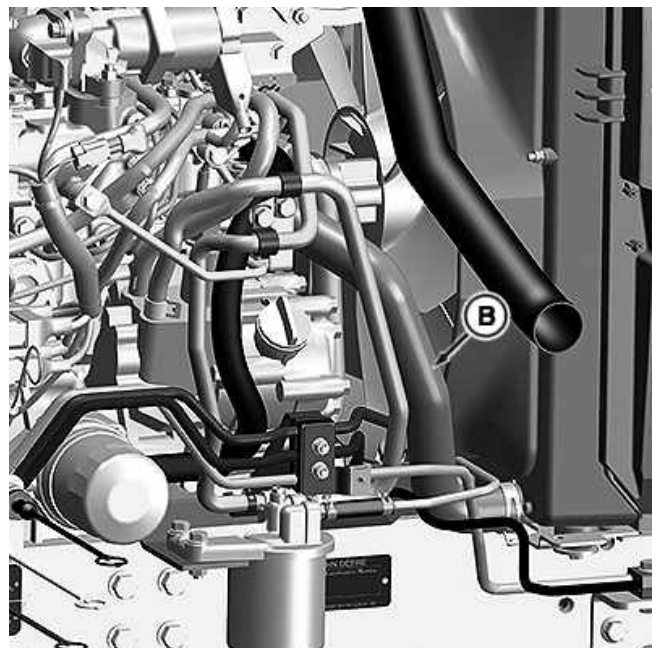

A - Upper Radiator Hose B - Lower Radiator Hose

7. Remove air cleaner assembly. See “Air Cleaner Assembly Removal and Installation” in this manual.

8. Remove mid SCV quick-connect couplers (A), cap screws (B), spacers (C), and bracket (D). To prevent dirt from getting in hydraulic lines, plug hydraulic lines and openings.

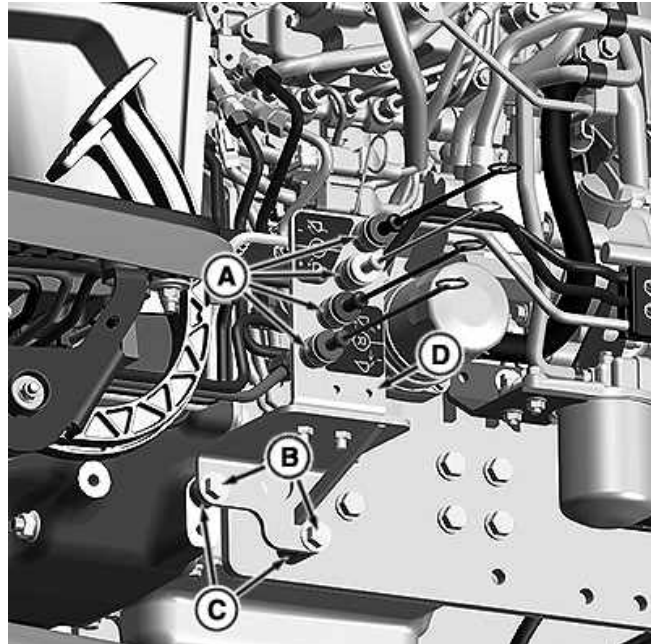

LV25949-UN: Mid SCV Coupler Bracket (2038R shown; 2032R similar)

- A - Mid SCV Quick-Connect Couplers (4 used)**
- B - Cap Screws (2 used)**
- C - Spacers (2 used)**
- D - Bracket**

9. **NOTE:**

Mark fuel lines for assembly.

Remove fuel lines (A—D), hydraulic oil charge line (E), and guard (F). Plug lines and openings to prevent dirt from entering lines, fuel tank, fuel cooler, and oil cooler.

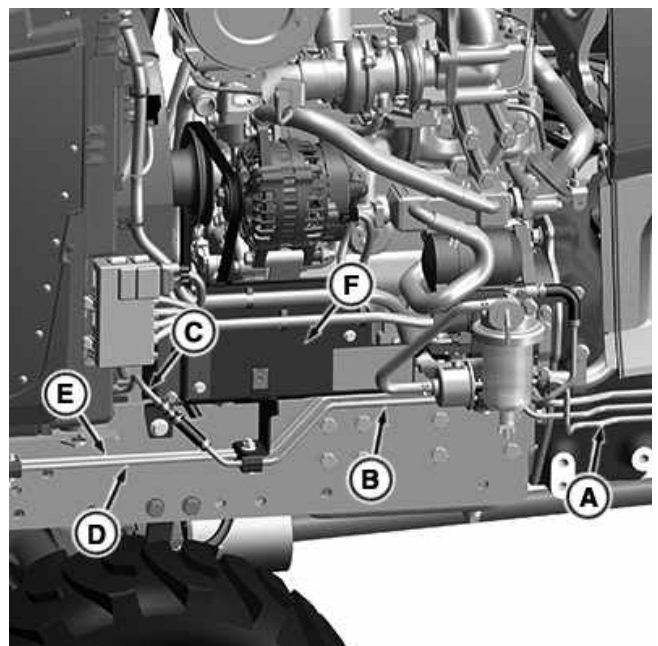

LV25951-UN: Fuel Lines and Left Finger Guard (2038R shown; 2032R similar)

This as a preview PDF file from best-manuals.com



Download full PDF manual at best-manuals.com