

2050M
Tier 4A (interim)
Crawler Dozer

PIN NCDC25000 and above; PIN NDDC25000 and above
PIN NEDC20000 and above; PIN NFDC20000 and above

SERVICE MANUAL

Part number 47907871

2nd edition English

October 2015

Replaces part number 47645618



Link Product / Engine

Product	Market Product	Engine
2050M Long Track (LT), Power Angle Tilt (PAT) Blade [NCDC25000 -]	North America	F4HFE613J*A007
2050M Long Track (LT), Power Angle Tilt (PAT) Blade [NDDC25000 -]	North America	F4HFE613J*A007
2050M Long Track (LT), Power Angle Tilt (PAT) Blade [NEDC20000 -]	North America	F4HFE613J*A007
2050M Long Track (LT), Power Angle Tilt (PAT) Blade [NFDC20000 -]	North America	F4HFE613J*A007
2050M Long Track (LT), Bulldozer (BD) Blade [NCDC25000 -]	North America	F4HFE613J*A007
2050M Long Track (LT), Bulldozer (BD) Blade [NDDC25000 -]	North America	F4HFE613J*A007
2050M Long Track (LT), Bulldozer (BD) Blade [NEDC20000 -]	North America	F4HFE613J*A007
2050M Long Track (LT), Bulldozer (BD) Blade [NFDC20000 -]	North America	F4HFE613J*A007
2050M Extra Long Track (XLT), Power Angle Tilt (PAT) Blade [NCDC25000 -]	North America	F4HFE613J*A007
2050M Extra Long Track (XLT), Power Angle Tilt (PAT) Blade [NDDC25000 -]	North America	F4HFE613J*A007
2050M Extra Long Track (XLT), Power Angle Tilt (PAT) Blade [NEDC20000 -]	North America	F4HFE613J*A007
2050M Extra Long Track (XLT), Power Angle Tilt (PAT) Blade [NFDC20000 -]	North America	F4HFE613J*A007
2050M Wide Track (WT) / Low Ground Pressure (LGP), Power Angle Tilt (PAT) Blade [NCDC25000 -]	North America	F4HFE613J*A007
2050M Wide Track (WT) / Low Ground Pressure (LGP), Power Angle Tilt (PAT) Blade [NDDC25000 -]	North America	F4HFE613J*A007
2050M Wide Track (WT) / Low Ground Pressure (LGP), Power Angle Tilt (PAT) Blade [NEDC20000 -]	North America	F4HFE613J*A007
2050M Wide Track (WT) / Low Ground Pressure (LGP), Power Angle Tilt (PAT) Blade [NFDC20000 -]	North America	F4HFE613J*A007

Product	Market Product	Engine
2050M Extended Long Track (XLT), Bulldozer (BD) Blade [NCDC25000 -]	North America	F4HFE613J*A007
2050M Extended Long Track (XLT), Bulldozer (BD) Blade [NDDC25000 -]	North America	F4HFE613J*A007
2050M Extended Long Track (XLT), Bulldozer (BD) Blade [NEDC20000 -]	North America	F4HFE613J*A007
2050M Extended Long Track (XLT), Bulldozer (BD) Blade [NFDC20000 -]	North America	F4HFE613J*A007
2050M Wide Track (WT) / Low Ground Pressure (LGP), Bulldozer (BD) Blade [NCDC25000 -]	North America	F4HFE613J*A007
2050M Wide Track (WT) / Low Ground Pressure (LGP), Bulldozer (BD) Blade [NDDC25000 -]	North America	F4HFE613J*A007
2050M Wide Track (WT) / Low Ground Pressure (LGP), Bulldozer (BD) Blade [NEDC20000 -]	North America	F4HFE613J*A007
2050M Wide Track (WT) / Low Ground Pressure (LGP), Bulldozer (BD) Blade [NFDC20000 -]	North America	F4HFE613J*A007

Contents

INTRODUCTION

Engine.....	10
[10.001] Engine and crankcase	10.1
[10.216] Fuel tanks	10.2
[10.206] Fuel filters	10.3
[10.202] Air cleaners and lines	10.4
[10.250] Turbocharger and lines.....	10.5
[10.500] Selective Catalytic Reduction (SCR) exhaust treatment.....	10.6
[10.400] Engine cooling system	10.7
[10.414] Fan and drive	10.8
[10.310] Aftercooler.....	10.9
[10.304] Engine lubrication system.....	10.10
Hydrostatic drive.....	29
[29.218] Pump and motor components.....	29.1
Brakes and controls	33
[33.110] Parking brake or parking lock	33.1
[33.202] Hydraulic service brakes	33.2
Hydraulic systems.....	35
[35.300] Reservoir, cooler, and filters.....	35.1
[35.104] Fixed displacement pump.....	35.2
[35.106] Variable displacement pump	35.3
[35.105] Charge pump.....	35.4
[35.359] Main control valve.....	35.5
[35.741] Dozer blade cylinders	35.6
[35.525] Auxiliary hydraulic valves and lines	35.7
[35.752] Hydraulic fan drive cooling system.....	35.8

[35.000] Hydraulic systems	35.9
Frames and ballasting	39
[39.100] Frame	39.1
Tracks and track suspension	48
[48.130] Track frame and driving wheels	48.1
[48.100] Tracks	48.2
[48.134] Track tension units	48.3
[48.138] Track rollers	48.4
[48.140] Dropbox and final drive	48.5
Cab climate control	50
[50.100] Heating	50.1
[50.104] Ventilation	50.2
[50.200] Air conditioning	50.3
Electrical systems	55
[55.000] Electrical system	55.1
[55.011] Fuel tank system	55.2
[55.015] Engine control system	55.3
[55.030] Service brake electrical system	55.4
[55.050] Heating, Ventilation, and Air-Conditioning (HVAC) control system	55.5
[55.100] Harnesses and connectors	55.6
[55.201] Engine starting system	55.7
[55.202] Cold start aid	55.8
[55.301] Alternator	55.9
[55.302] Battery	55.10
[55.408] Warning indicators, alarms, and instruments	55.11
[55.512] Cab controls	55.12
[55.518] Wiper and washer system	55.13
[55.988] Selective Catalytic Reduction (SCR) electrical system	55.14

[55.DTC] FAULT CODES.....	55.15
Dozer blade and arm.....	86
[86.110] Dozer blade	86.1
[86.124] Dozer pushbeams and struts	86.2
Tools	89
[89.128] Ripper assembly	89.1
Platform, cab, bodywork, and decals.....	90
[90.150] Cab.....	90.1
[90.114] Operator protections	90.2
[90.124] Pneumatically-adjusted operator seat.....	90.3
[90.100] Engine hood and panels	90.4



INTRODUCTION

Contents

INTRODUCTION

Foreword - Important notice regarding equipment servicing (*)	3
Safety rules (*)	4
Safety rules - Personal safety (*)	5
Safety rules - Ecology and the environment (*)	12
Safety rules - Do not operate tag (*)	13
Basic instructions - Shop and assembly (*)	14
Torque - Minimum tightening torques for normal assembly (*)	16
Torque - Standard torque data for hydraulics (*)	19
Torque - Special torques (*)	21
Engine cooling system - Basic instructions (*)	23
Maintenance chart (*)	25
Basic instructions - Moving a disabled machine (*)	27
Hydraulic contamination (*)	36
Conversion factors (*)	37
Consumables - Loctite® product chart (*)	39
Engine lubrication system - Consumables (*)	45
Capacities (*)	46
Product identification (*)	49
Product identification - Machine orientation (*)	51

(*) See content for specific models

Foreword - Important notice regarding equipment servicing

2050M

NA

All repair and maintenance work listed in this manual must be carried out only by qualified dealership personnel, strictly complying with the instructions given, and using, whenever possible, the special tools.

Anyone who performs repair and maintenance operations without complying with the procedures provided herein shall be responsible for any subsequent damages.

The manufacturer and all the organizations of its distribution chain, including - without limitation - national, regional, or local dealers, reject any responsibility for damages caused by parts and/or components not approved by the manufacturer, including those used for the servicing or repair of the product manufactured or marketed by the manufacturer. In any case, no warranty is given or attributed on the product manufactured or marketed by the manufacturer in case of damages caused by parts and/or components not approved by the manufacturer.

The manufacturer reserves the right to make improvements in design and changes in specifications at any time without notice and without incurring any obligation to install them on units previously sold. Specifications, descriptions, and illustrative material herein are as accurate as known at time of publication but are subject to change without notice.

In case of questions, refer to your CASE CONSTRUCTION Sales and Service Networks.

Safety rules

2050M

NA

Personal safety





This is the safety alert symbol. It is used to alert you to potential personal injury hazards. Obey all safety messages that follow this symbol to avoid possible death or injury.

Throughout this manual you will find the signal words DANGER, WARNING, and CAUTION followed by special instructions. These precautions are intended for the personal safety of you and those working with you.

Read and understand all the safety messages in this manual before you operate or service the machine.

 DANGER indicates a hazardous situation that, if not avoided, will result in death or serious injury.

 WARNING indicates a hazardous situation that, if not avoided, could result in death or serious injury.

 CAUTION indicates a hazardous situation that, if not avoided, could result in minor or moderate injury.

FAILURE TO FOLLOW DANGER, WARNING, AND CAUTION MESSAGES COULD RESULT IN DEATH OR SERIOUS INJURY.

Machine safety

NOTICE: Notice indicates a situation that, if not avoided, could result in machine or property damage.

Throughout this manual you will find the signal word Notice followed by special instructions to prevent machine or property damage. The word Notice is used to address practices not related to personal safety.

Information

NOTE: Note indicates additional information that clarifies steps, procedures, or other information in this manual.

Throughout this manual you will find the word Note followed by additional information about a step, procedure, or other information in the manual. The word Note is not intended to address personal safety or property damage.

Safety rules - Personal safety

2050M

NA

General safety rules

Use caution when you operate the machine on slopes. Raised equipment, full tanks and other loads will change the center of gravity of the machine. The machine can tip or roll over when near ditches and embankments or uneven surfaces.

Never permit anyone other than the operator to ride on the machine.

Never operate the machine under the influence of alcohol or drugs, or while you are otherwise impaired.

When digging or using ground-engaging attachments, be aware of buried cables. Contact local utilities to determine the locations of services.

Pay attention to overhead power lines and hanging obstacles. High voltage lines may require significant clearance for safety.

Hydraulic oil or diesel fuel leaking under pressure can penetrate the skin, causing serious injury or infection.

- DO NOT use your hand to check for leaks. Use a piece of cardboard or paper.
- Stop the engine, remove the key, and relieve the pressure before you connect or disconnect fluid lines.
- Make sure that all components are in good condition. Tighten all connections before you start the engine or pressurize the system.
- If hydraulic fluid or diesel fuel penetrates the skin, seek medical attention immediately.
- Continuous long term contact with hydraulic fluid may cause skin cancer. Avoid long term contact and wash the skin promptly with soap and water.

Keep clear of moving parts. Loose clothing, jewelry, watches, long hair, and other loose or hanging items can become entangled in moving parts.

Wear protective equipment when appropriate.

DO NOT attempt to remove material from any part of the machine while it is being operated or while components are in motion.

Make sure that all guards and shields are in good condition and properly installed before you operate the machine. Never operate the machine with shields removed. Always close access doors or panels before you operate the machine.

Dirty or slippery steps, ladders, walkways, and platforms can cause falls. Make sure these surfaces remain clean and clear of debris.

A person or pet within the operating area of a machine can be struck or crushed by the machine or its equipment. DO NOT allow anyone to enter the work area.

Raised equipment and/or loads can fall unexpectedly and crush persons underneath. Never allow anyone to enter the area underneath raised equipment during operation.

Never operate the engine in enclosed spaces as harmful exhaust gases may build up.

Before you start the machine, be sure that all controls are in neutral or park lock position.

Start the engine only from the operator's seat. If you bypass the safety start switch, the engine can start with the transmission in gear. Do not connect or short across terminals on the starter solenoid. Attach jumper cables as described in the manual. Starting in gear may cause death or serious injury.

Always keep windows, mirrors, and all lighting clean to provide the best possible visibility while you operate the machine.

Operate controls only when seated in the operator's seat, except for those controls expressly intended for use from other locations.

Before you leave the machine:

1. Park the machine on a firm, level surface.
2. Put all controls in neutral or park lock position.
3. Engage the parking brake. Use wheel chocks if required.
4. Lower all hydraulic equipment — Implements, header, etc.
5. Turn off the engine and remove the key.

When, due to exceptional circumstances, you would decide to keep the engine running after you leave the operator's station, then you must follow these precautions:

1. Bring the engine to low idle speed.
2. Disengage all drive systems.

3. **▲ WARNING**

**Some components may continue to run down after disengaging drive systems.
Make sure all drive systems are fully disengaged.
Failure to comply could result in death or serious injury.**

W0113A

Shift the transmission into neutral.

4. Apply the parking brake.

▲ General maintenance safety ▲

Keep the area used for servicing the machine clean and dry. Clean up spilled fluids.

Service the machine on a firm, level surface.

Install guards and shields after you service the machine.

Close all access doors and install all panels after servicing the machine.

Do not attempt to clean, lubricate, clear obstructions, or make adjustments to the machine while it is in motion or while the engine is running.

Always make sure that working area is clear of tools, parts, other persons and pets before you start operating the machine.

Unsupported hydraulic cylinders can lose pressure and drop the equipment, causing a crushing hazard. Do not leave equipment in a raised position while parked or during service, unless the equipment is securely supported.

Jack or lift the machine only at jack or lift points indicated in this manual.

Incorrect towing procedures can cause accidents. When you tow a disabled machine follow the procedure in this manual. Use only rigid tow bars.

Stop the engine, remove the key, and relieve pressure before you connect or disconnect fluid lines.

Stop the engine and remove the key before you connect or disconnect electrical connections.

Scalding can result from incorrect removal of coolant caps. Cooling systems operate under pressure. Hot coolant can spray out if you remove a cap while the system is hot. Allow the system to cool before you remove the cap. When you remove the cap, turn it slowly to allow pressure to escape before you completely remove the cap.

Replace damaged or worn tubes, hoses, electrical wiring, etc.

The engine, transmission, exhaust components, and hydraulic lines may become hot during operation. Take care when you service such components. Allow surfaces to cool before you handle or disconnect hot components. Wear protective equipment when appropriate.

When welding, follow the instructions in the manual. Always disconnect the battery before you weld on the machine. Always wash your hands after you handle battery components.

Fire and explosion prevention

Fuel or oil that is leaked or spilled on hot surfaces or electrical components can cause a fire.

Crop materials, trash, debris, bird nests, or flammable material can ignite on hot surfaces.

Always have a fire extinguisher on or near the machine.

Make sure that the fire extinguisher(s) is maintained and serviced according to the manufacturer's instructions.

At least once each day and at the end of the day, remove all trash and debris from the machine especially around hot components such as the engine, transmission, exhaust, battery, etc. More frequent cleaning of your machine may be necessary depending on the operating environment and conditions.

At least once each day, remove debris accumulation around moving components such as bearings, pulleys, belts, gears, cleaning fans, etc. More frequent cleaning of your machine may be necessary depending on the operating environment and conditions.

Inspect the electrical system for loose connections and frayed insulation. Repair or replace loose or damaged parts.

Do not store oily rags or other flammable material on the machine.

Do not weld or flame cut any items that contain flammable material. Clean items thoroughly with non-flammable solvents before welding or flame-cutting.

Do not expose the machine to flames, burning brush, or explosives.

Promptly investigate any unusual smells or odors that may occur during operation of the machine.

General battery safety

Always wear eye protection when you work with batteries.

Do not create sparks or have open flame near a battery.

Ventilate the area when you charge a battery or use a battery in an enclosed area.

Disconnect the negative (-) terminal first and reconnect the negative (-) terminal last.

When you weld on the machine, disconnect both terminals of the battery.

Do not weld, grind, or smoke near a battery.

When you use auxiliary batteries or connect jumper cables to start the engine, use the procedure shown in the operator's manual. Do not short across terminals.

Follow the manufacturer's instructions when you store and handle batteries.

Battery post, terminals, and related accessories contain lead and lead compounds. Wash hands after handling. This is a California Proposition 65 warning.

Battery acid causes burns. Batteries contain sulfuric acid. Avoid contact with skin, eyes, or clothing. Antidote (external): Flush with water. Antidote (eyes): flush with water for 15 minutes and seek medical attention immediately. Antidote (internal): Drink large quantities of water or milk. Do not induce vomiting. Seek medical attention immediately.

Keep out of reach of children and other unauthorized persons.

⚠ Operator presence system ⚠

Your machine is equipped with an operator presence system to prevent the use of some features while the operator is not in the operator's seat.

Never disconnect or bypass the operator presence system.

If the operator presence system is inoperable, then it must be repaired.

⚠ Seat belts ⚠

Seat belts must be worn at all times.

Seat belt inspection and maintenance:

- Keep seat belts in good condition.
- Keep sharp edges and items that can cause damage away from the belts.
- Periodically check belts, buckles, retractors, tethers, slack take-up system, and mounting bolts for damage and wear.
- Replace all parts that have damage or wear.
- Replace belts that have cuts that can make the belt weak.
- Check that bolts are tight on the seat bracket or mounting.
- If the belt is attached to the seat, make sure that the seat or seat brackets are mounted securely.
- Keep seat belts clean and dry.
- Clean belts only with soap solution and warm water.
- Do not use bleach or dye on the belts because this can make the belts weak.

Pull the right-hand belt from the seat belt retractor. Fasten the metal belt end into the left-hand buckle.

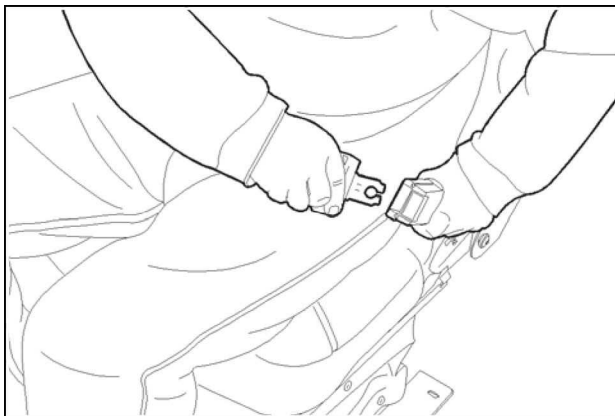

RCIL10CWL037AAL 1

Press the red button on the left-hand seat belt mechanism to release the seat belt.

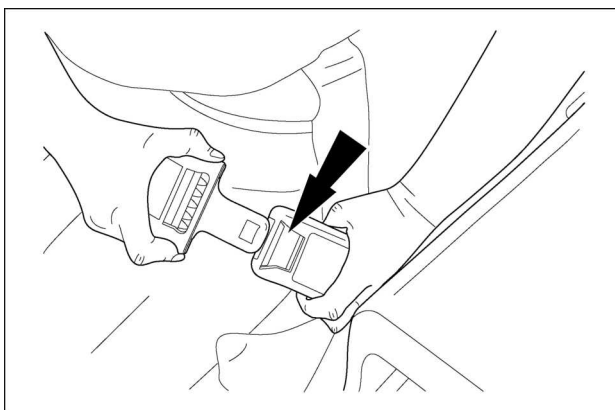

RCIL10CWL083FAL 2

Operator protective structure

Your machine is equipped with an operator protective structure, such as: a Roll Over Protective Structure (ROPS), Falling Objects Protective Structure (FOPS), or a cab with a ROPS. A ROPS may be a can frame or a two-posted or four-posted structure used for the protection of the operator to minimize the possibility of serious injury. The mounting structure and fasteners forming the mounting connection with the machine are part of the ROPS.

The protective structure is a special safety component of your machine.

DO NOT attach any device to the protective structure for pulling purposes. DO NOT drill holes to the protective structure.

The protective structure and interconnecting components are a certified system. Any damage, fire, corrosion, or modification will weaken the structure and reduce your protection. If this occurs, THE PROTECTIVE STRUCTURE MUST BE REPLACED so that it will provide the same protection as a new protective structure. Contact your dealer for protective structure inspection and replacement.

After an accident, fire, tip over, or roll over, the following MUST be performed by a qualified technician before returning the machine to field or job-site operations:

- The protective structure MUST BE REPLACED.
- The mounting or suspension for the protective structure, operator's seat and suspension, seat belts and mounting components, and wiring within the operator's protective system MUST be carefully inspected for damage.
- All damaged parts MUST BE REPLACED.

DO NOT WELD, DRILL HOLES, ATTEMPT TO STRAIGHTEN, OR REPAIR THE PROTECTIVE STRUCTURE. MODIFICATION IN ANY WAY CAN REDUCE THE STRUCTURAL INTEGRITY OF THE STRUCTURE, WHICH COULD CAUSE DEATH OR SERIOUS INJURY IN THE EVENT OF FIRE, TIP OVER, ROLL OVER, COLLISION, OR ACCIDENT.

Seat belts are part of your protective system and must be worn at all times. The operator must be held to the seat inside the frame in order for the protective system to work.

Air-conditioning system

The air-conditioning system is under high pressure. Do not disconnect any lines. The release of high pressure can cause serious injury.

The air-conditioning system contains gases that are harmful to the environment when released into the atmosphere. Do not attempt to service or repair the system.

Only trained service technicians can service, repair, or recharge the air-conditioning system.

Backup alarm system

Do not disconnect backup alarm system if so equipped.

Personal Protective Equipment (PPE)

Wear Personal Protective Equipment (PPE) such as hard hat, eye protection, heavy gloves, hearing protection, protective clothing, etc.

Do Not Operate tag

Before you start servicing the machine, attach a 'Do Not Operate' warning tag to the machine in an area that will be visible.

Hazardous chemicals

If you are exposed to or come in contact with hazardous chemicals you can be seriously injured. The fluids, lubricants, paints, adhesives, coolant, etc. required for the function of your machine can be hazardous. They may be attractive and harmful to domestic animals as well as humans.

Material Safety Data Sheets (MSDS) provide information about the chemical substances within a product, safe handling and storage procedures, first aid measures, and procedures to take in the event of a spill or accidental release. MSDS are available from your dealer.

Before you service your machine check the MSDS for each lubricant, fluid, etc. used in this machine. This information indicates the associated risks and will help you service the machine safely. Follow the information in the MSDS, and on manufacturer containers, as well as the information in this manual, when you service the machine.

Dispose of all fluids, filters, and containers in an environmentally safe manner according to local laws and regulations. Check with local environmental and recycling centers or your dealer for correct disposal information.

Store fluids and filters in accordance with local laws and regulations. Use only appropriate containers for the storage of chemicals or petrochemical substances.

Keep out of reach of children or other unauthorized persons.

Applied chemicals require additional precautions. Obtain complete information from the manufacturer or distributor of the chemicals before you use them.

Utility safety

When digging or using ground-engaging equipment, be aware of buried cables and other services. Contact your local utilities or authorities, as appropriate, to determine the locations of services.

Make sure that the machine has sufficient clearance to pass in all directions. Pay special attention to overhead power lines and hanging obstacles. High voltage lines may require significant clearance for safety. Contact local authorities or utilities to obtain safe clearance distances from high voltage power lines.

Retract raised or extended components, if necessary. Remove or lower radio antennas or other accessories. Should a contact between the machine and an electric power source occur, the following precautions must be taken:

- Stop the machine movement immediately.
- Apply the parking brake, stop the engine, and remove the key.
- Check if you can safely leave the cab or your actual position without contact with electrical wires. If not, stay in your position and call for help. If you can leave your position without touching lines, jump clear of the machine to make sure that you do not make contact with the ground and the machine at the same time.
- Do not permit anyone to touch the machine until power has been shut off to the power lines.

Electrical storm safety

Do not operate machine during an electrical storm.

If you are on the ground during an electrical storm, stay away from machinery and equipment. Seek shelter in a permanent, protected structure.

If an electrical storm should strike during operation, remain in the cab. Do not leave the cab or operator's platform. Do not make contact with the ground or objects outside the machine.

Mounting and dismounting

Mount and dismount the machine only at designated locations that have handholds, steps, and/or ladders.

Do not jump off of the machine.

Make sure that steps, ladders, and platforms remain clean and clear of debris and foreign substances. Injury may result from slippery surfaces.

Face the machine when you mount and dismount the machine.

Maintain a three-point contact with steps, ladders, and handholds.

Never mount or dismount from a moving machine.

Do not use the steering wheel or other controls or accessories as handholds when you enter or exit the cab or operator's platform.

Working at heights

When the normal use and maintenance of the machine requires you to work at heights:

- Correctly use installed steps, ladders, and railings.
- Never use ladders, steps, or railings while the machine is moving.
- Do not stand on surfaces that are not designated as steps or platforms.

Do not use the machine as a lift, ladder, or platform for working at heights.

Lifting and overhead loads

Never use loader buckets, forks, etc. or other lifting, handling, or digging equipment to lift persons.

Do not use raised equipment as a work platform.

Know the full area of movement of the machine and equipment and do not enter or permit anyone to enter the area of movement while the machine is in operation.

Never enter or permit anyone to enter the area underneath raised equipment. Equipment and/or loads can fall unexpectedly and crush persons underneath it.

Do not leave equipment in raised position while parked or during service, unless securely supported. Hydraulic cylinders must be mechanically locked or supported if they are left in a raised position for service or access.

Loader buckets, forks, etc. or other lifting, handling, or digging equipment and its load will change the center of gravity of the machine. This can cause the machine to tip on slopes or uneven ground.

Load items can fall off the loader bucket or lifting equipment and crush the operator. Care must be taken when lifting a load. Use proper lifting equipment.

Do not lift load higher than necessary. Lower loads to transport. Remember to leave appropriate clearance to the ground and other obstacles.

Equipment and associated loads can block visibility and cause an accident. Do not operate with insufficient visibility.

Safety rules - Ecology and the environment

2050M

NA

Soil, air, and water quality is important for all industries and life in general. When legislation does not yet rule the treatment of some of the substances that advanced technology requires, sound judgment should govern the use and disposal of products of a chemical and petrochemical nature.

Familiarize yourself with the relative legislation applicable to your country, and make sure that you understand this legislation. Where no legislation exists, obtain information from suppliers of oils, filters, batteries, fuels, anti-freeze, cleaning agents, etc., with regard to the effect of these substances on man and nature and how to safely store, use, and dispose of these substances.

Helpful hints

- Avoid the use of cans or other inappropriate pressurized fuel delivery systems to fill tanks. Such delivery systems may cause considerable spillage.
- In general, avoid skin contact with all fuels, oils, acids, solvents, etc. Most of these products contain substances that may be harmful to your health.
- Modern oils contain additives. Do not burn contaminated fuels and or waste oils in ordinary heating systems.
- Avoid spillage when you drain fluids such as used engine coolant mixtures, engine oil, hydraulic fluid, brake fluid, etc. Do not mix drained brake fluids or fuels with lubricants. Store all drained fluids safely until you can dispose of the fluids in a proper way that complies with all local legislation and available resources.
- Do not allow coolant mixtures to get into the soil. Collect and dispose of coolant mixtures properly.
- The air-conditioning system contains gases that should not be released into the atmosphere. Consult an air-conditioning specialist or use a special extractor to recharge the system properly.
- Repair any leaks or defects in the engine cooling system or hydraulic system immediately.
- Do not increase the pressure in a pressurized circuit as this may lead to a component failure.
- Protect hoses during welding. Penetrating weld splatter may burn a hole or weaken hoses, allowing the loss of oils, coolant, etc.

Battery recycling

Batteries and electric accumulators contain several substances that can have a harmful effect on the environment if the batteries are not properly recycled after use. Improper disposal of batteries can contaminate the soil, groundwater, and waterways. CASE CONSTRUCTION strongly recommends that you return all used batteries to a CASE CONSTRUCTION dealer, who will dispose of the used batteries or recycle the used batteries properly. In some countries, this is a legal requirement.



Mandatory battery recycling

NOTE: *The following requirements are mandatory in Brazil.*

Batteries are made of lead plates and a sulfuric acid solution. Because batteries contain heavy metals such as lead, CONAMA Resolution 401/2008 requires you to return all used batteries to the battery dealer when you replace any batteries. Do not dispose of batteries in your household garbage.

Points of sale are obliged to:

- Accept the return of your used batteries
- Store the returned batteries in a suitable location
- Send the returned batteries to the battery manufacturer for recycling

Safety rules - Do not operate tag

2050M

NA

⚠ WARNING

Maintenance hazard!

Before you start servicing the machine, attach a DO NOT OPERATE warning tag to the machine in a visible area.

Failure to comply could result in death or serious injury.

W0004A

Attach a DO NOT OPERATE (TAG) to the machine in an area that is clearly visible whenever the machine is not operating properly and/or requires service.

Complete the tag information for the "REASON" the tag is attached by describing the malfunction or service required. Validate the reason for attaching the tag by signing your name in the designated area on the tag.

The tag should only be removed by the person who signed and attached the tag, after validating the repairs or services have been completed.

(A)		(D)
(B)	<p>See Other Side</p>	(E)
(C)	<p>CNH Part Number 87358697</p> <p>Printed in U.S.A.</p>	(F)

87358697 1

Tag Components

- A. DO NOT REMOVE THIS TAG! - (Warning) The tag should only be removed by the person who signed and attached the tag, after validating the repairs or services have been completed.
- B. See Other Side - (Reference to additional information on opposite side of the tag.)
- C. CNH Part Number - (Request this part number from you Service Parts Dealer to obtain this DO NOT OPERATE tag.)
- D. DO NOT OPERATE - (Warning!)
- E. REASON - (Area for describing malfunction or service required before operation.)
- F. Signed by - (Signature area - to be signed by the person validating the reason for installation of the tag.)

Basic instructions - Shop and assembly

2050M

NA

Shimming

For each adjustment operation, select adjusting shims and measure the adjusting shims individually using a micrometer, then add up the recorded values. Do not rely on measuring the entire shimming set, which may be incorrect, or the rated value shown on each shim.

Rotating shaft seals

For correct rotating shaft seal installation, proceed as follows:

1. Before assembly, allow the seal to soak in the oil it will be sealing for at least thirty minutes.
2. Thoroughly clean the shaft and check that the working surface on the shaft is not damaged.
3. Position the sealing lip facing the fluid.

NOTE: *With hydrodynamic lips, take into consideration the shaft rotation direction and position the grooves so that they will move the fluid towards the inner side of the seal.*

4. Coat the sealing lip with a thin layer of lubricant (use oil rather than grease). Fill the gap between the sealing lip and the dust lip on double lip seals with grease.
5. Insert the seal in its seat and press down using a flat punch or seal installation tool. Do not tap the seal with a hammer or mallet.
6. While you insert the seal, check that the seal is perpendicular to the seat. When the seal settles, make sure that the seal makes contact with the thrust element, if required.
7. To prevent damage to the seal lip on the shaft, position a protective guard during installation operations.

O-ring seals

Lubricate the O-ring seals before you insert them in the seats. This will prevent the O-ring seals from overturning and twisting, which would jeopardize sealing efficiency.

Sealing compounds

Apply a sealing compound on the mating surfaces when specified by the procedure. Before you apply the sealing compound, prepare the surfaces as directed by the product container.

Spare parts

Only use CNH Original Parts or CASE CONSTRUCTION Original Parts.

Only genuine spare parts guarantee the same quality, duration, and safety as original parts, as they are the same parts that are assembled during standard production. Only CNH Original Parts or CASE CONSTRUCTION Original Parts can offer this guarantee.

When ordering spare parts, always provide the following information:

- Machine model (commercial name) and Product Identification Number (PIN)
- Part number of the ordered part, which can be found in the parts catalog

Protecting the electronic and/or electrical systems during charging and welding

To avoid damage to the electronic and/or electrical systems, always observe the following practices:

1. Never make or break any of the charging circuit connections when the engine is running, including the battery connections.
2. Never short any of the charging components to ground.
3. Always disconnect the ground cable from the battery before arc welding on the machine or on any machine attachment.
 - Position the welder ground clamp as close to the welding area as possible.
 - If you weld in close proximity to a computer module, then you should remove the module from the machine.
 - Never allow welding cables to lie on, near, or across any electrical wiring or electronic component while you weld.
4. Always disconnect the negative cable from the battery when charging the battery in the machine with a battery charger.

NOTICE: *If you must weld on the unit, you must disconnect the battery ground cable from the machine battery. The electronic monitoring system and charging system will be damaged if this is not done.*

5. Remove the battery ground cable. Reconnect the cable when you complete welding.

⚠ WARNING

Battery acid causes burns. Batteries contain sulfuric acid.

Avoid contact with skin, eyes or clothing. Antidote (external): Flush with water. Antidote (eyes): flush with water for 15 minutes and seek medical attention immediately. Antidote (internal): Drink large quantities of water or milk. Do not induce vomiting. Seek medical attention immediately. Failure to comply could result in death or serious injury.

W0111A

Special tools

The special tools that CASE CONSTRUCTION suggests and illustrate in this manual have been specifically researched and designed for use with CASE CONSTRUCTION machines. The special tools are essential for reliable repair operations. The special tools are accurately built and rigorously tested to offer efficient and long-lasting operation.

By using these tools, repair personnel will benefit from:

- Operating in optimal technical conditions
- Obtaining the best results
- Saving time and effort
- Working in safe conditions

Torque - Minimum tightening torques for normal assembly

2050M	NA
-------	----

Decimal hardware

Grade 5 bolts, nuts and studs

Size	Nm	lb in/lb ft
1/4 in	12 - 15 Nm	108 - 132 lb in
5/16 in	23 - 28 Nm	204 - 252 lb in
3/8 in	48 - 57 Nm	420 - 504 lb in
7/16 in	73 - 87 Nm	54 - 64 lb ft
1/2 in	109 - 130 Nm	80 - 96 lb ft
9/16 in	149 - 179 Nm	110 - 132 lb ft
5/8 in	203 - 244 Nm	150 - 180 lb ft
3/4 in	366 - 439 Nm	270 - 324 lb ft
7/8 in	542 - 651 Nm	400 - 480 lb ft
1 in	787 - 944 Nm	580 - 696 lb ft
1-1/8 in	1085 - 1193 Nm	800 - 880 lb ft
1-1/4 in	1519 - 1681 Nm	1120 - 1240 lb ft
1-3/8 in	1980 - 2278 Nm	1460 - 1680 lb ft
1-1/2 in	2631 - 2983 Nm	1940 - 2200 lb ft

Grade 8 bolts, nuts and studs

Size	Nm	lb in/lb ft
1/4 in	16 - 20 Nm	144 - 180 lb in
5/16 in	33 - 39 Nm	288 - 348 lb in
3/8 in	61 - 73 Nm	540 - 648 lb in
7/16 in	95 - 114 Nm	70 - 84 lb ft
1/2 in	149 - 179 Nm	110 - 132 lb ft
9/16 in	217 - 260 Nm	160 - 192 lb ft
5/8 in	298 - 358 Nm	220 - 264 lb ft
3/4 in	515 - 618 Nm	380 - 456 lb ft
7/8 in	814 - 976 Nm	600 - 720 lb ft
1 in	1220 - 1465 Nm	900 - 1080 lb ft
1-1/8 in	1736 - 1953 Nm	1280 - 1440 lb ft
1-1/4 in	2468 - 2712 Nm	1820 - 2000 lb ft
1-3/8 in	3227 - 3688 Nm	2380 - 2720 lb ft
1-1/2 in	4285 - 4827 Nm	3160 - 3560 lb ft

NOTE: Use thick nuts with Grade 8 bolts.

Metric hardware

Grade 8.8 bolts, nuts and studs

Size	Nm	lb in/lb ft
4 mm	3 - 4 Nm	24 - 36 lb in
5 mm	7 - 8 Nm	60 - 72 lb in
6 mm	11 - 12 Nm	96 - 108 lb in
8 mm	26 - 31 Nm	228 - 276 lb in
10 mm	52 - 61 Nm	456 - 540 lb in
12 mm	90 - 107 Nm	66 - 79 lb ft
14 mm	144 - 172 Nm	106 - 127 lb ft
16 mm	217 - 271 Nm	160 - 200 lb ft
20 mm	434 - 515 Nm	320 - 380 lb ft
24 mm	675 - 815 Nm	500 - 600 lb ft
30 mm	1250 - 1500 Nm	920 - 1100 lb ft
36 mm	2175 - 2600 Nm	1600 - 1950 lb ft

Grade 10.9 bolts, nuts and studs

Size	Nm	lb in/lb ft
4 mm	4 - 5 Nm	36 - 48 lb in
5 mm	9 - 11 Nm	84 - 96 lb in
6 mm	15 - 18 Nm	132 - 156 lb in
8 mm	37 - 43 Nm	324 - 384 lb in
10 mm	73 - 87 Nm	54 - 64 lb ft
12 mm	125 - 150 Nm	93 - 112 lb ft
14 mm	200 - 245 Nm	149 - 179 lb ft
16 mm	310 - 380 Nm	230 - 280 lb ft
20 mm	610 - 730 Nm	450 - 540 lb ft
24 mm	1050 - 1275 Nm	780 - 940 lb ft
30 mm	2000 - 2400 Nm	1470 - 1770 lb ft
36 mm	3500 - 4200 Nm	2580 - 3090 lb ft

Grade 12.9 bolts, nuts and studs

Size	Nm	lb in/lb ft
Typically the torque values specified for grade 10.9 hardware can be used satisfactorily on grade 12.9 hardware.		

Steel hydraulic fittings

37° flare fitting

Tube outside diameter/Hose inside diameter		Thread size	Nm	lb in/lb ft
mm	inch			
6.4 mm	1/4 in	7/16-20 in	8 - 16 Nm	72 - 144 lb in
7.9 mm	5/16 in	1/2-20 in	11 - 22 Nm	96 - 192 lb in
9.5 mm	3/8 in	9/16-18 in	14 - 34 Nm	120 - 300 lb in
12.7 mm	1/2 in	3/4-16 in	20 - 57 Nm	180 - 504 lb in
15.9 mm	5/6 in	7/8-14 in	34 - 79 Nm	300 - 696 lb in
19.0 mm	3/4 in	1-1/16-12 in	54 - 108 Nm	40 - 80 lb ft
22.2 mm	7/8 in	1-3/16-12 in	81 - 135 Nm	60 - 100 lb ft
25.4 mm	1 in	1-5/16-12 in	102 - 158 Nm	75 - 117 lb ft
31.8 mm	1-1/4 in	1-5/8-12 in	169 - 223 Nm	125 - 165 lb ft
38.1 mm	1-1/2 in	1-7/8-12 in	285 - 338 Nm	210 - 250 lb ft

Straight threads with O-ring

Tube outside diameter/Hose inside diameter		Thread size	Nm	lb in/lb ft
mm	inch			
6.4 mm	1/4 in	7/16-20 in	16 - 26 Nm	144 - 228 lb in
7.9 mm	5/16 in	1/2-20 in	22 - 34 Nm	192 - 300 lb in
9.5 mm	3/8 in	9/16-18 in	34 - 54 Nm	300 - 480 lb in
12.7 mm	1/2 in	3/4-16 in	57 - 91 Nm	540 - 804 lb in
15.9 mm	5/6 in	7/8-14 in	79 - 124 Nm	58 - 92 lb ft
19.0 mm	3/4 in	1-1/16-12 in	108 - 174 Nm	80 - 128 lb ft
22.2 mm	7/8 in	1-3/16-12 in	136 - 216 Nm	100 - 160 lb ft
25.4 mm	1 in	1-5/16-12 in	159 - 253 Nm	117 - 187 lb ft
31.8 mm	1-1/4 in	1-5/8-12 in	224 - 357 Nm	165 - 264 lb ft
38.1 mm	1-1/2 in	1-7/8-12 in	339 - 542 Nm	250 - 400 lb ft

Split flange mounting bolts

Size	Nm	lb in/lb ft
5/16-18 in	20 - 27 Nm	180 - 240 lb in
3/8-16 in	27 - 34 Nm	240 - 300 lb in
7/16-14 in	47 - 61 Nm	420 - 540 lb in
1/2-13 in	74 - 88 Nm	55 - 65 lb ft

INTRODUCTION

Size	Nm	lb in/lb ft
5/8-11 in	190 - 203 Nm	140 - 150 lb ft

Nominal SAE dash size	O-ring face seal end		Thread size	Nm	lb in/lb ft	O-ring boss end fitting or lock nut		
	Tube outside diameter mm	in				Thread size	Nm	lb in/lb ft
-4	6.4 mm	1/4 in	9/16-18 in	14 - 16 Nm	120 - 144 lb in	7/16-20 in	23 - 27 Nm	204 - 240 lb in
-6	9.5 mm	3/8 in	11/16-16 in	24 - 27 Nm	216 - 240 lb in	9/16-18 in	34 - 41 Nm	300 - 360 lb in
-8	12.7 mm	1/2 in	13/16-16 in	43 - 54 Nm	384 - 480 lb in	3/4-16 in	61 - 68 Nm	540 - 600 lb in
-10	15.9 mm	5/8 in	1-14 in	62 - 76 Nm	552 - 672 lb in	7/8-14 in	81 - 88 Nm	60 - 65 lb ft
-12	19.0 mm	3/4 in	1-3/16-12 in	90 - 110 Nm	65 - 80 lb ft	1-1/16-12 in	115 - 122 Nm	85 - 90 lb ft
-14	22.2 mm	7/8 in	1-3/16-12 in	90 - 110 Nm	65 - 80 lb ft	1-13/16-12 in	129 - 136 Nm	95 - 100 lb ft
-16	25.41 mm	1.0 in	1-7/16-12 in	125 - 140 Nm	92 - 105 lb ft	1-5/16-12 in	156 - 169 Nm	115 - 125 lb ft
-20	31.8 mm	1-1/4 in	1-11/16-12 in	170 - 190 Nm	125 - 140 lb ft	1-5/6-12 in	201 - 217 Nm	150 - 160 lb ft
-24	38.1 mm	1-1/2 in	2-12 in	200 - 254 Nm	150 - 180 lb ft	1-7/8-12 in	258 - 271 Nm	190 - 200 lb ft

Torque - Standard torque data for hydraulics

2050M

NA

Installation of adjustable fittings in straight thread O-ring bosses

1. Lubricate the O-ring by coating it with a light oil or petroleum. Install the O-ring in the groove adjacent to the metal backup washer which is assembled at the extreme end of the groove (4).
2. Install the fitting into the SAE straight thread boss until the metal backup washer contacts the face of the boss (5).

NOTE: Do not over tighten and distort the metal backup washer.

3. Position the fitting by turning out (counterclockwise) up to a maximum of one turn. Holding the pad of the fitting with a wrench, tighten the locknut and washer against the face of the boss (6).

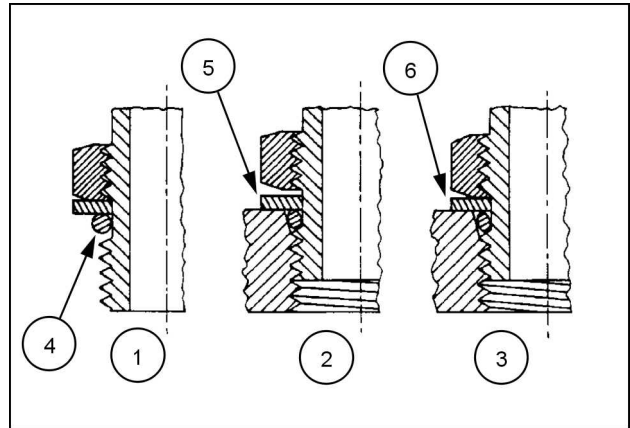

23085659 1

Standard torque data for hydraulic tubes and fittings

Tube nuts for 37° flared fittings				O-ring boss plugs adjustable fitting locknuts, swivel JIC-37° seats
Size	Tubing OD	Thread size	Torque	Torque
4	6.4 mm (1/4 in)	7/16-20	12 - 16 N·m (9 - 12 lb ft)	8 - 14 N·m (6 - 10 lb ft)
5	7.9 mm (5/16 in)	1/2-20	16 - 20 N·m (12 - 15 lb ft)	14 - 20 N·m (10 - 15 lb ft)
6	9.5 mm (3/8 in)	9/16-18	29 - 33 N·m (21 - 24 lb ft)	20 - 27 N·m (15 - 20 lb ft)
8	12.7 mm (1/2 in)	3/4-16	47 - 54 N·m (35 - 40 lb ft)	34 - 41 N·m (25 - 30 lb ft)
10	15.9 mm (5/8 in)	7/8-14	72 - 79 N·m (53 - 58 lb ft)	47 - 54 N·m (35 - 40 lb ft)
12	19.1 mm (3/4 in)	1-1/16-12	104 - 111 N·m (77 - 82 lb ft)	81 - 95 N·m (60 - 70 lb ft)
14	22.2 mm (7/8 in)	1-3/16-12	122 - 136 N·m (90 - 100 lb ft)	95 - 109 N·m (70 - 80 lb ft)
16	25.4 mm (1 in)	1-5/16-12	149 - 163 N·m (110 - 120 lb ft)	108 - 122 N·m (80 - 90 lb ft)
20	31.8 mm (1-1/4 in)	1-5/8-12	190 - 204 N·m (140 - 150 lb ft)	129 - 158 N·m (95 - 115 lb ft)
24	38.1 mm (1-1/2 in)	1-7/8-12	217 - 237 N·m (160 - 175 lb ft)	163 - 190 N·m (120 - 140 lb ft)
32	50.8 mm (2 in)	2-1/2-12	305 - 325 N·m (225 - 240 lb ft)	339 - 407 N·m (250 - 300 lb ft)

These torques are not recommended for tubes of 12.7 mm (1/2 in) OD and larger with wall thickness of 0.889 mm (0.035 in) or less. The torque is specified for 0.889 mm (0.035 in) wall tubes on each application individually.

Before installing and torquing 37° flared fittings, clean the face of the flare and threads with a clean solvent or Loctite cleaner and apply hydraulic sealant **LOCTITE® 569™** to the 37° flare and the threads.

Install fitting and torque to specified torque, loosen fitting and retorque to specifications.

Pipe thread fitting torque

Before installing and tightening pipe fittings, clean the threads with a clean solvent or Loctite cleaner and apply sealant **LOCTITE® 567™ PST PIPE SEALANT** for all fittings including stainless steel or **LOCTITE® 565™ PST** for most metal fittings. For high filtration/zero contamination systems use **LOCTITE® 545™**.

Thread size	Torque (maximum)
1/8-27	13 N·m (10 lb ft)
1/4-18	16 N·m (12 lb ft)
3/8-18	22 N·m (16 lb ft)
1/2-14	41 N·m (30 lb ft)
3/4-14	54 N·m (40 lb ft)

Installation of ORFS (O-Ring Flat Seal fittings)

When installing ORFS fittings thoroughly clean both flat surfaces of the fittings **(1)** and lubricate the O-ring **(2)** with light oil. Make sure both surfaces are aligned properly. Torque the fitting to specified torque listed throughout the repair manual.

NOTICE: *If the fitting surfaces are not properly cleaned, the O-ring will not seal properly. If the fitting surfaces are not properly aligned, the fittings may be damaged and will not seal properly.*

NOTICE: *Always use genuine factory replacement oils and filters to ensure proper lubrication and filtration of engine and hydraulic system oils.*

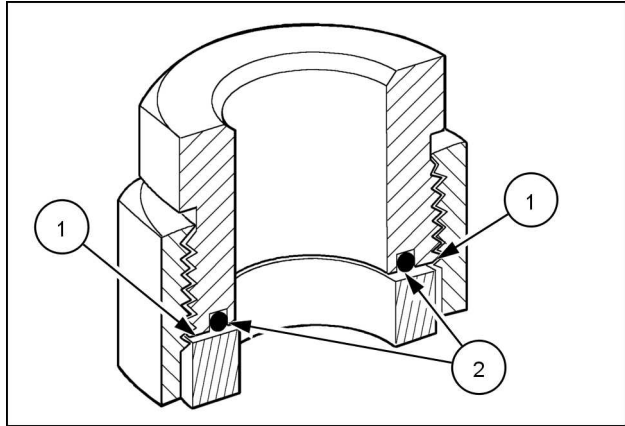

50011183 2

The use of proper oils, grease, and keeping the hydraulic system clean will extend machine and component life.

Torque - Special torques

2050M	NA
-------	----

Ripper

Component	Torque
Ripper mounting bolts	1016 - 1375 N·m (749 - 1014 lb ft)
Ripper pin retaining and tube cover bolts	301 - 407 N·m (222 - 300 lb ft)

Fuse and Relay Blocks

Component	Torque
Fuse block mounting	6.5 N·m (4.8 lb ft)

Pumps and Motors

Component	Torque
Pump mount bolts to cover	587 - 690 N·m (433 - 509 lb ft)
Motor mount bolts to final drives	250 - 280 N·m (184 - 207 lb ft)
Pump to motor hoses spit flange clamps	90 - 100 Nm (66 - 74 lb ft)
Inlet hose clamps	6.5 - 7.6 Nm (58 - 68 lb in)

Rear Frame Cover

Component	Torque
M24 hex bolts	449 - 725 N·m (331 - 535 lb ft)
M16 hex bolts	230 - 371 N·m (170 - 274 lb ft)

Track

Component	Torque
Master link bolts (Use LOCTITE® 242® on master link bolts.)	610 - 670 N·m (450 - 494 lb ft)
Standard link shoe bolts	610 - 670 N·m (450 - 494 lb ft)

Final Drives

Component	Torque
Drive Hub Rolling Torque	10 - 24 N·m (7 - 18 lb ft)
Input Shaft Bearing Retainer Plate Mounting Bolts	77 - 87 N·m (57 - 64 lb ft)
Park Brake Housing Plate	77 - 87 N·m (57 - 64 lb ft)
Brake Housing Cover - M20 X 50 12 pnt	650 - 730 N·m (479 - 538 lb ft)
Brake Line Fitting	55 - 60 N·m (41 - 44 lb ft)
Brake Bleeder Fitting	24 - 30 N·m (18 - 22 lb ft)
Counter Shaft Bearing Retainer Plate Mounting Bolts	135 - 150 N·m (100 - 111 lb ft)
Spindle Housing	335 - 375 N·m (247 - 277 lb ft)
Ring Gear Retaining Plate	335 - 375 N·m (247 - 277 lb ft)
Sun Gear Shaft Retaining Plate	135 - 150 N·m (100 - 111 lb ft)
Output Gear Bearing Retainer Plate Mounting Bolts	135 - 150 N·m (100 - 111 lb ft)
Planetary Carrier to Drive Hub	335 - 375 N·m (247 - 277 lb ft)
Final Drive Housing to Frame Mounting Bolts	656 - 725 N·m (484 - 535 lb ft)
Fill Check Plug	24 - 30 N·m (18 - 22 lb ft)
Drain Plug	24 - 30 N·m (18 - 22 lb ft)

Cab Mounting

Component	Torque
Support mount bolts	733 - 854 N·m (541 - 630 lb ft)
Brush guard mount bolts (if equipped)	587 - 794 N·m (433 - 586 lb ft)

INTRODUCTION

Air Conditioning Compressor

Component	Torque
Compressor rotor shaft nut	15 - 20 Nm (11 - 15 lb ft)
Oil filler plug	15 - 24 Nm (11 - 18 lb ft)
Dust cover screws	7 - 11 Nm (5 - 8 lb ft)

Lift Cylinder

Component	Torque
Piston bolt	2160 - 2450 N·m (1593 - 1807 lb ft)
Gland	135 - 542 Nm (100 - 400 lb ft)

Tilt Cylinder

Component	Torque
Piston bolt	2160 - 2450 N·m (1593 - 1807 lb ft)
Gland	135 - 542 Nm (100 - 400 lb ft)

Angle Cylinder

Component	Torque
Piston bolt	2160 - 2450 N·m (1593 - 1807 lb ft)
Gland	135 - 542 Nm (100 - 400 lb ft)

Ripper Cylinder

Component	Torque
Piston bolt	2830 - 3210 N·m (2087 - 2368 lb ft)
Gland	135 - 542 Nm (100 - 400 lb ft)

Starter

Component	Torque
Mounting bolts	68 - 77 Nm (50 - 57 lb ft)
Battery terminal nut	17.7 - 24.5 Nm (13 - 18 lb ft)
Solenoid + screw	2.6 - 4.5 Nm (23 - 40 lb in)

Multifunction valve

Component	Torque
Brake valve	3 - 4 N·m (2 - 3 lb ft)
Brake valve screws	3 - 4 N·m (2 - 3 lb ft)
Cartridge valve	32.6 - 35.4 N·m (24.0 - 26.1 lb ft)
Check valve	150 - 177 N·m (111 - 131 lb ft)

Powertrain specifications

Component	Torque
Cradle to chassis front	185 - 200 N·m (136 - 148 lb ft)
Cradle to chassis rear	70 - 80 N·m (52 - 59 lb ft)
Hydrostatic motor mounting bolts to park brake housing	250 - 280 N·m (184 - 207 lb ft)
Engine to coupler	41 - 50 N·m (30 - 37 lb ft)
Tandem pump to cradle rear mounting bracket	265 - 305 N·m (195 - 225 lb ft)
Hydrostatic pump to pump mounting plate	587 - 690 N·m (433 - 509 lb ft)
Pump coupler retainer plate	136 - 156 N·m (100 - 115 lb ft)
Cradle mid mount	225 - 305 N·m (166 - 225 lb ft)
Engine to cradle front	107 - 123 N·m (79 - 91 lb ft)

Engine cooling system - Basic instructions

2050M

NA

Depending on the date of manufacture, your cooling system may be equipped with conventional ethylene glycol coolant such as **CNH XHD HEAVY DUTY COOLANT / ANTI-FREEZE** or an Organic Acid Technology (OAT) coolant solution such as **CASE AKCELA ACTIFULL™ OT EXTENDED LIFE COOLANT**. You can easily identify **CASE AKCELA ACTIFULL™ OT EXTENDED LIFE COOLANT** by its yellow color. You should never mix the coolant types.

The coolant solution used must meet the following CNH Industrial material specifications for either coolant type:

- **MAT3624** for OAT coolant
- **MAT3620** for conventional coolant

The decal shown is located near the fill point of the cooling system whenever the factory fill is **CASE AKCELA ACTIFULL™ OT EXTENDED LIFE COOLANT**. This decal is available in three different sizes. See the table below for the associated part numbers.

CNH Industrial part number	Size
47757330	50 mm x 50 mm
47757331	75 mm x 75 mm
47757332	100 mm x 100 mm

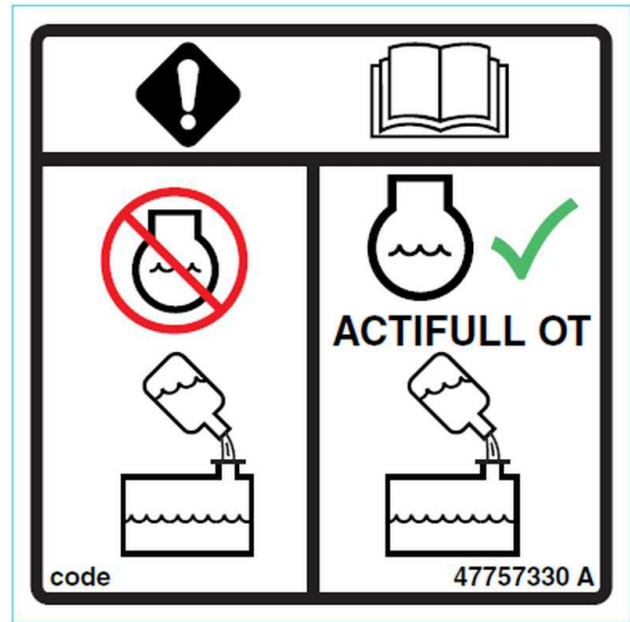

47757330 1

NOTICE: NEVER mix OAT coolant with conventional coolant. Under no circumstances should you top off a cooling system with only water. You can use a refractometer to check the concentration level. You should not use Supplemental Coolant Additives (SCA) when using **CASE AKCELA ACTIFULL™ OT EXTENDED LIFE COOLANT**. Change the coolant solution at the recommended change interval.

If you need to change a machine from conventional coolant to OAT coolant or vice versa, you should follow the “Changing coolant types” procedure below to attain the full benefit of the coolant.

Changing coolant types

To change coolant from OAT coolant to conventional coolant (or vice versa):

1. Empty the engine cooling system by draining the coolant into a suitable container.
2. Fill the system with clean water.
3. Start the engine and run the engine for at least **30 min**.

NOTE: Make sure that you activate the heating system (if equipped) to circulate fluid through the heater core.

4. Repeat Steps 1 to 3 for a total of two washes.
5. Fill the system with conventional coolant (or OAT coolant).
6. Operate the engine until it is warm. Inspect the machine for leaks.
7. If you are changing to OAT coolant, then attach the decal (CNH Industrial part number 47757330) to indicate the use of OAT coolant in the cooling system.

You may notice the older version of the OAT decal (CNH Industrial part number 47488993) on some applications.

Definitions

Conventional coolant:

A coolant that relies on inorganic inhibitors such as silicates, nitrites, and phosphates for corrosion and cavitation protection.

Organic Acid Technology (OAT) coolant:

A coolant that relies on inhibitors such as organic acid salts for corrosion and cavitation protection.

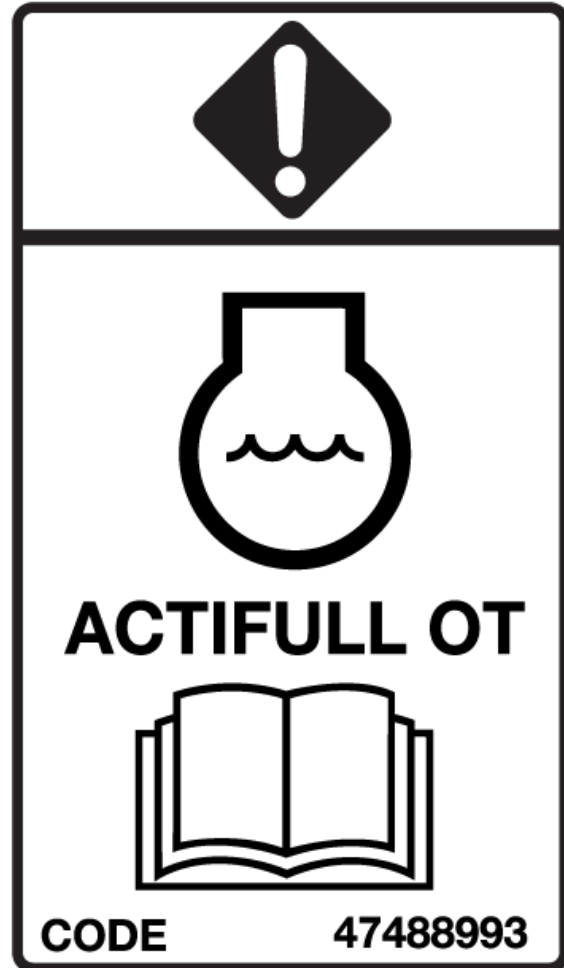

47488993 2

Maintenance chart

2050M | NA

Maintenance action	Cleaning				Change fluid			
	Check	Grease			Replace	Drain fluid		
Daily inspection								
General	x							
Every 10 hours								
Engine oil	x							
Engine coolant	x							
Hydraulic oil	x							
Grease points		x						
Bulldozer blade (optional) grease points		x						
Initial 20 hours								
Track shoe bolt torque	x							
Every 50 hours								
Fuel pre-filter - Drain condensation			x					
Initial 100 hours								
Change engine oil and filter (Initial)				x				
Replace hydraulic oil filters (Initial)					x			
Fuel filter (Initial)			x					
Clean in-line Diesel Exhaust Fluid (DEF) supply filter (Initial)			x					
Track tension (Initial)	x							
Final drive oil (initial)							x	
Every 500 hours								
Change engine oil and filter				x				
Fuel filter					x			
Battery electrolyte level	x							
Every 1000 hours								
Fuel tank sediment							x	
Fuel tank cap			x					
Hydraulic reservoir breather			x					
Final drive oil							x	
Every 1500 hours								
Clean in-line Diesel Exhaust Fluid (DEF) supply filter	x							
Drive belt					x			
Engine breather filter and valve clearance					x			
Every 2000 hours								
Engine coolant				x				
Hydraulic and hydrostatic drive filter and fluid					x			
Reservoir suction screen			x					
Engine air filters					x			
As required								
Track tension	x							
Roll Over Protective Structure (ROPS)	x							
Selective Catalytic Reduction (SCR) system - Replace supply module filter						x		
Cab air filter - Recirculation filter						x		
Selective Catalytic Reduction System (SCR) tank filter			x					
Doors and windows		x						
Ripper shanks and teeth						x		
Battery service			x					
Auxiliary battery connections	x							
Battery removal and installation						x		

INTRODUCTION

Maintenance action	Cleaning			Change fluid		
	Grease			Replace		
	Check			Drain fluid		
	Page no.					
Work lights				x		
ELECTRICAL SYSTEM						
Fuses and relays				x		

Basic instructions - Moving a disabled machine

2050M

NA

⚠ WARNING

Transport hazard!

Make sure that the weight of a trailed vehicle that is not equipped with brakes **NEVER EXCEEDS** the weight of the machine that is towing the vehicle. Stopping distance increases with increasing speed as the weight of the towed load increases, especially on hills and slopes.
Failure to comply could result in death or serious injury.

W1138A

Electronic override

1. Use the multi-function display screen to select the towing mode. From the main menu, scroll down and select "Service". Press the enter switch.

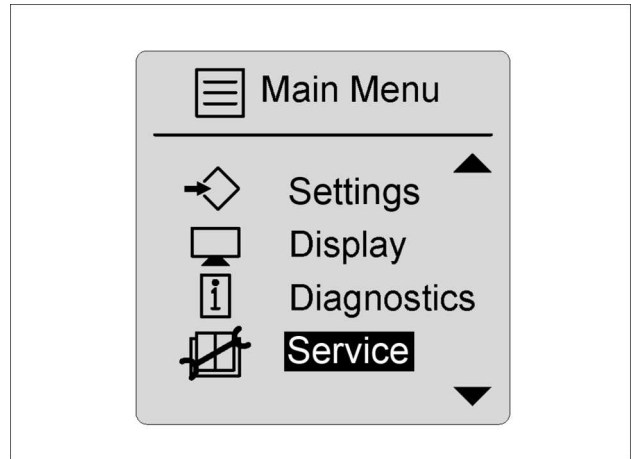

RAIL15DOZ0018AA 1

2. Scroll down, and highlight the "Tow Mode" selection. Press the enter switch.

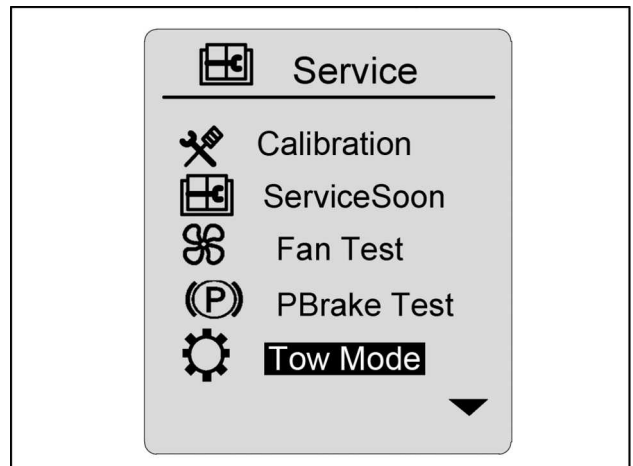

RAIL15DOZ0032AA 2

3. Change the Tow Mode from "Disabled" to "Enabled" by highlighting and pressing the enter switch.

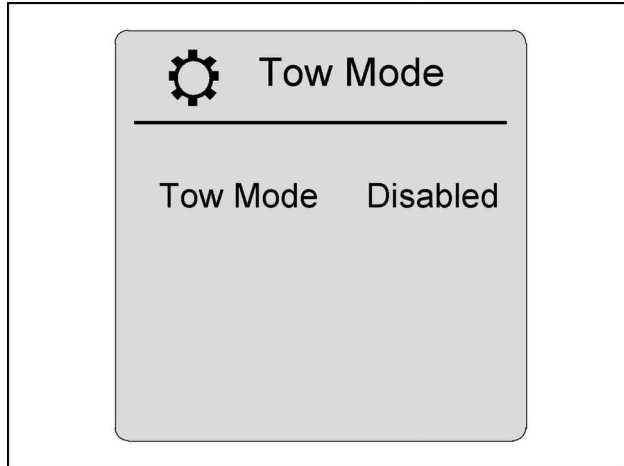

RAIL12DOZ0592AA 3

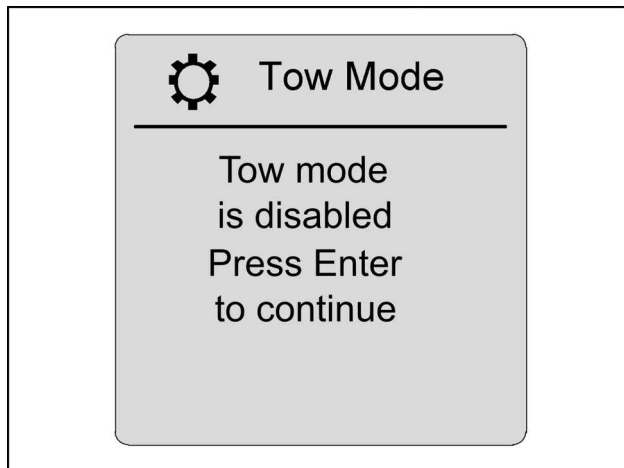

RAIL12DOZ0823AA 4

4. Continue to follow the screen prompts.

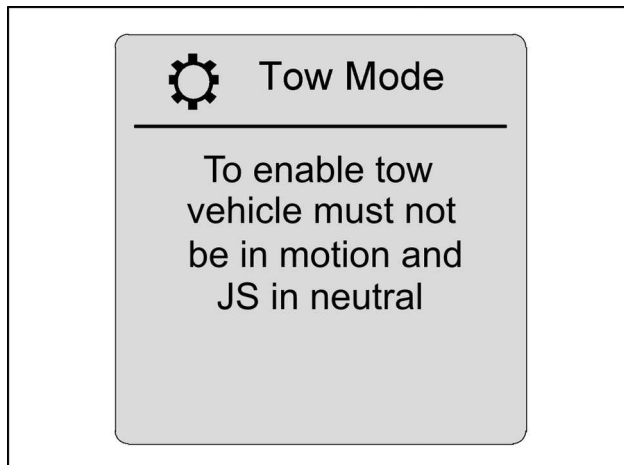

RAIL12DOZ0824AA 5

5. Read the procedure for releasing brakes later in this instruction.

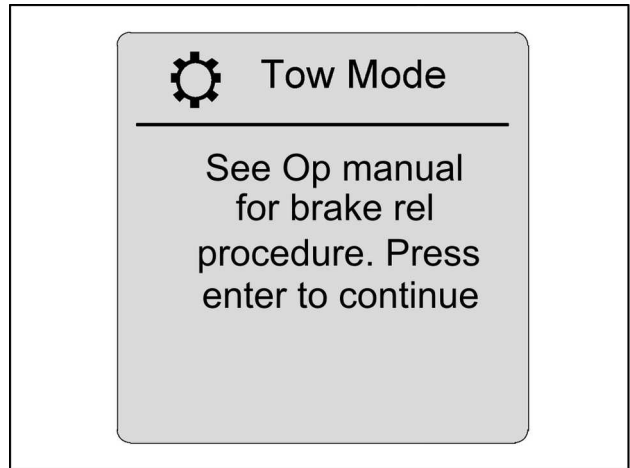

RAIL12DOZ0825AA 6

6. Press the enter switch to continue to the next screen.

NOTICE: Do not tow the machine over 1.2 km/h (0.7 mph).

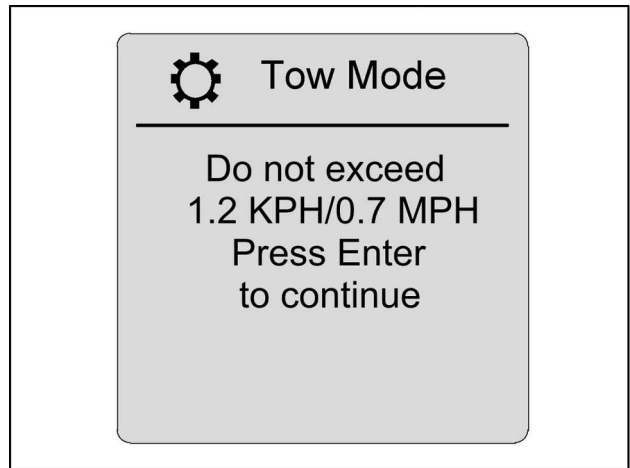

RAIL12DOZ0826AA 7

7. Press the enter switch to continue to the next screen.

NOTICE: Tow the machine the shortest possible distance.

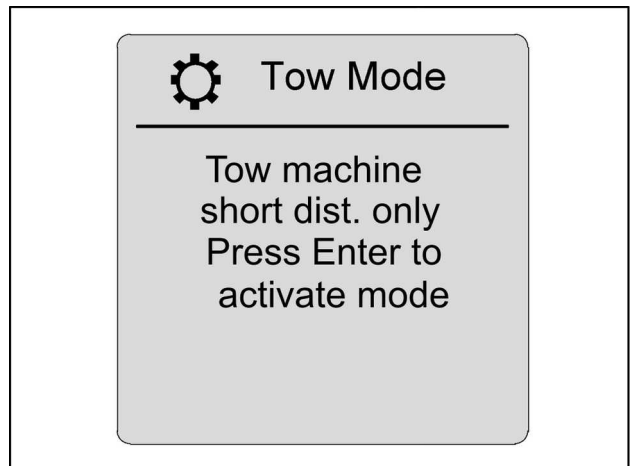

RAIL12DOZ0827AA 8

- The tow mode will be enabled. Wait for the next screen prompt before you tow the machine.

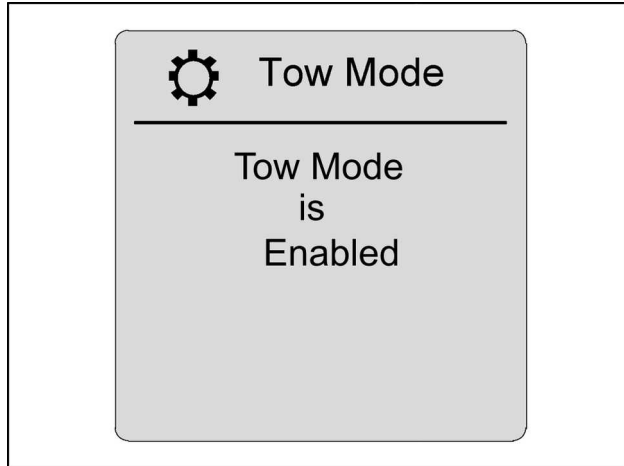

RAIL12DOZ0829AA 9

Bypass hydrostatic pumps

You must open the pressure relief valves in order to bypass the hydrostatic pumps. There are two valves located on each hydrostatic pump.

- Access the upper pressure relief valve by removing the floor mat (1), cab floor access panel, and tilting the operator seat back. The upper pressure relief valve (2) is located on the rear hydrostatic pump.

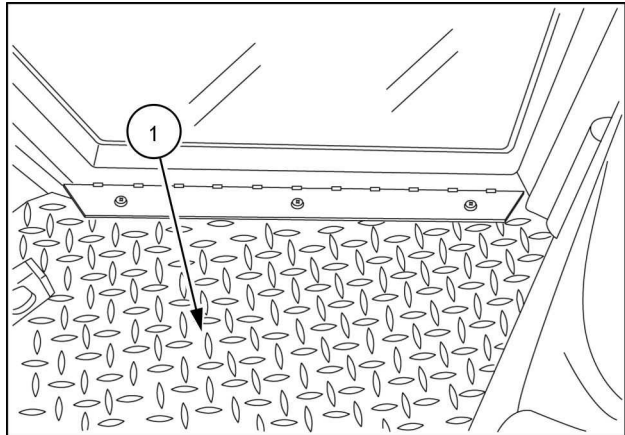

RAIL12DOZ0232AA 10

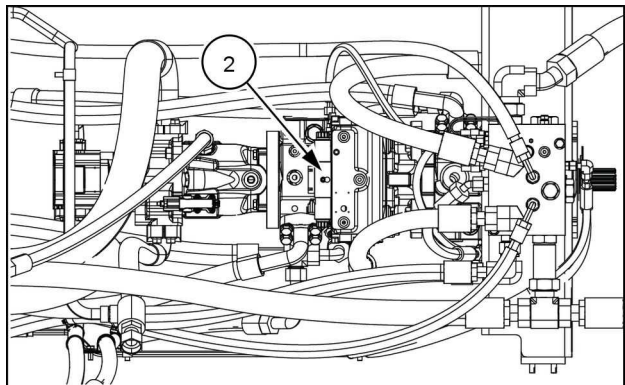

RAIL13DOZ1709AA 11

⚠ CAUTION

Heavy object!
The component is heavy. Use care not to drop the component when installing, removing, or handling.
Failure to comply could result in minor or moderate injury.

C0095A

10. Access the lower pressure relief valve by removing the center belly pan cover (3) underneath the machine. The lower pressure relief valve (4) is located on the front hydrostatic pump.

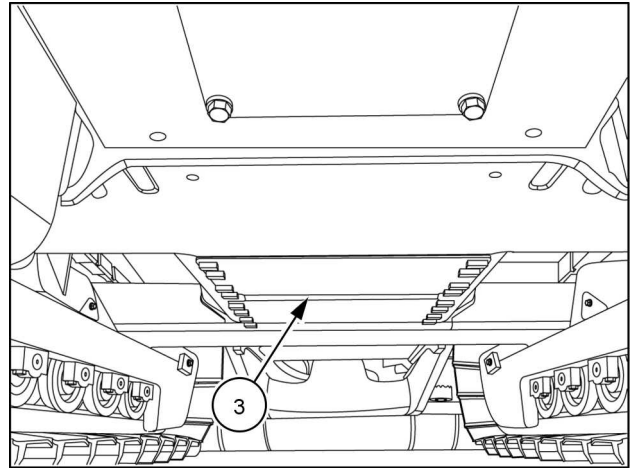

RAIL13DOZ0274AA 12

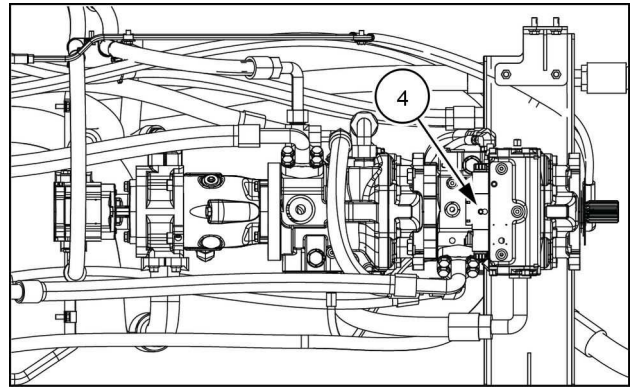

RAIL13DOZ1710AA 13

11. Remove the relief valve plastic caps (5) to access the engagement screws (6). The plastic caps will be unusable after removal and should be replaced.

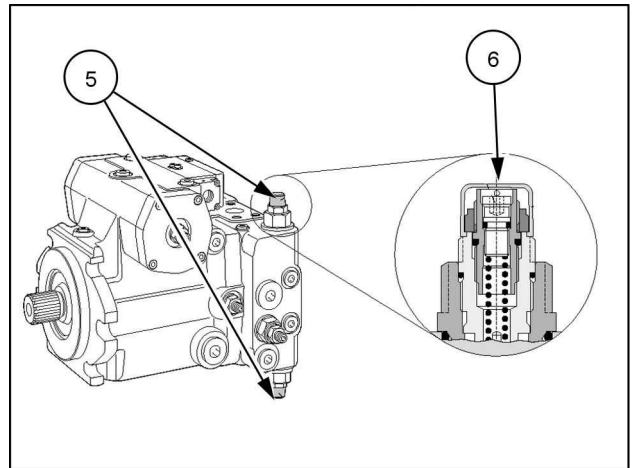

RAIL12DOZ0644AA 14

12. Use an Allen wrench, and turn the engagement screw (6) counterclockwise two turns on each relief valve.

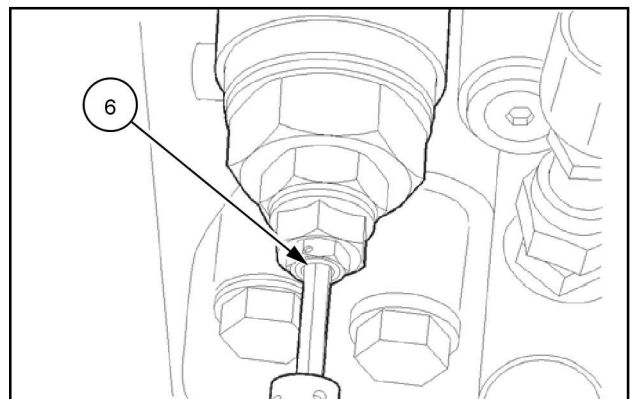

RCIL10CWL116AAL 15

Releasing the brakes

NOTE: This machine is equipped with a spring applied hydraulically released parking brakes. Hydraulic pressure must release the brakes. You **MUST** use a hand pump to release the brakes when the engine is not running.

13. Remove the hydraulic reservoir breather. Connect a vacuum pump at the hydraulic reservoir breather, and hold a vacuum to keep from losing fluid.

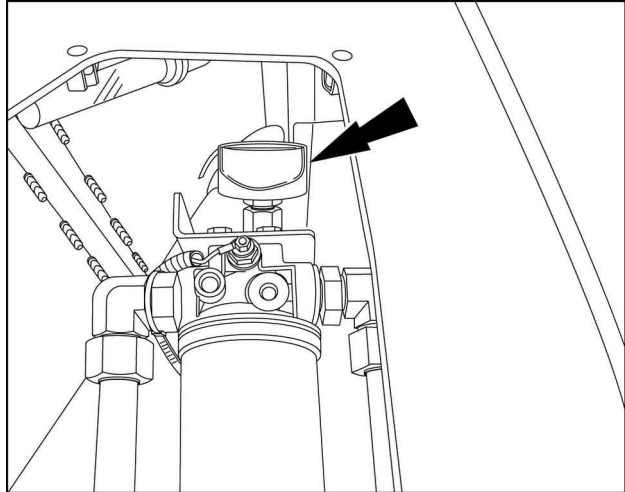

RAIL12DOZ0372AA 16

14. Disconnect the fittings (1) at the brake lines and cap the fittings. There are two brake lines. A Tee fitting will be required for the two lines in order to connect to the hand pump. If a T-fitting is not available, two pumps must be used.

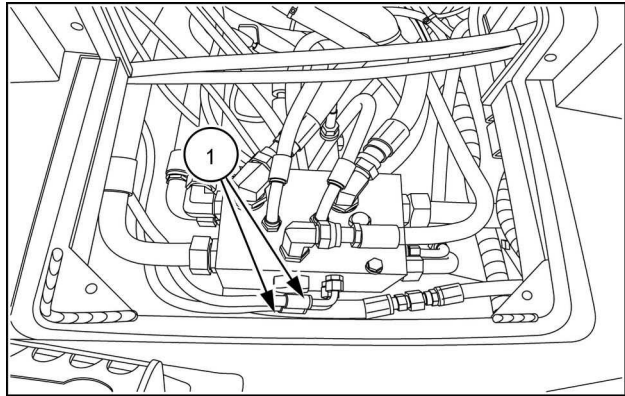

RAPH12DOZ0094AA 17

15. Connect a hand pump with the capacity to reach and maintain **22.7 bar (330 psi)**.
16. Operate the pump until the correct pressure is reached, and the brakes are released.
17. Check and maintain **22.7 bar (330 psi)** minimum in the brake line when moving the machine. Damage to the brake system can result if the pressure is reduced.
18. Tow the machine the shortest possible distance. Do not tow the machine over **1.2 km/h (0.7 mph)**.

Returning the unit to service

1. Disconnect the hand pump from the brake lines.
2. Remove the plugs, and reconnect the lines **(1)** to the brake solenoid.

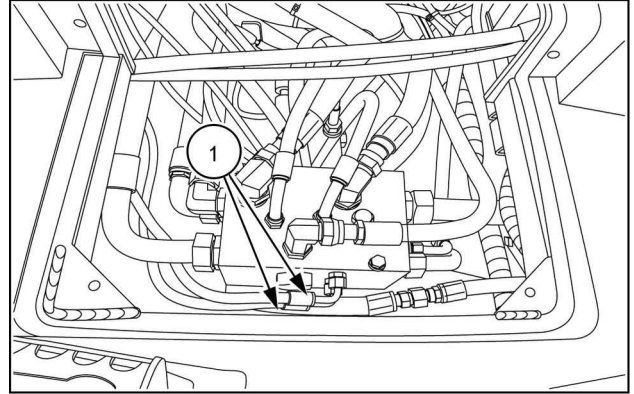

RAPH12DOZ0094AA 18

3. Remove the vacuum pump and install the hydraulic reservoir breather.

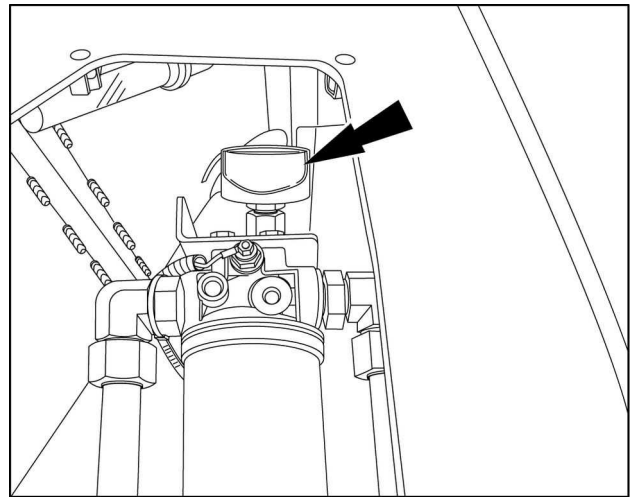

RAIL12DOZ0372AA 19

4. Turn the engagement screws clockwise two turns on each relief valve.

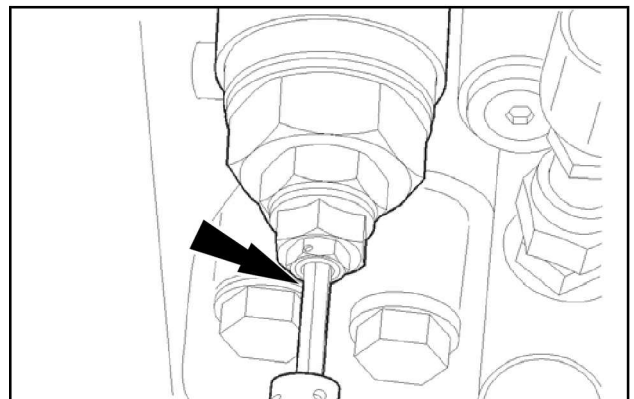

RCIL10CWL116AAL 20

INTRODUCTION

5. Install new plastic caps on each relief valve.
6. Reinstall the floor access panel and the belly pan.

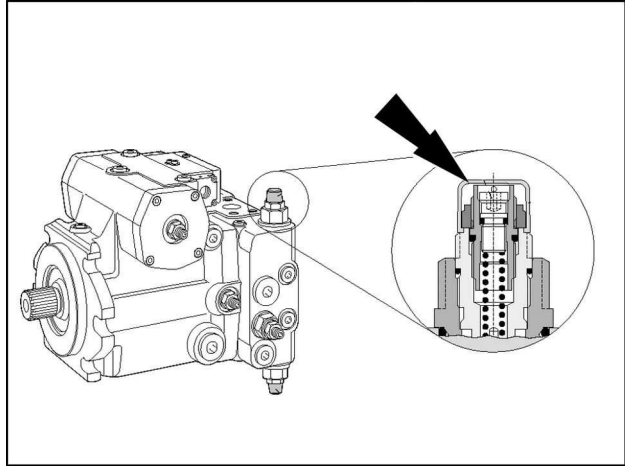

RAIL12DOZ0644AA 21

7. On the multi-function display screen, select "Service" and press the enter switch.

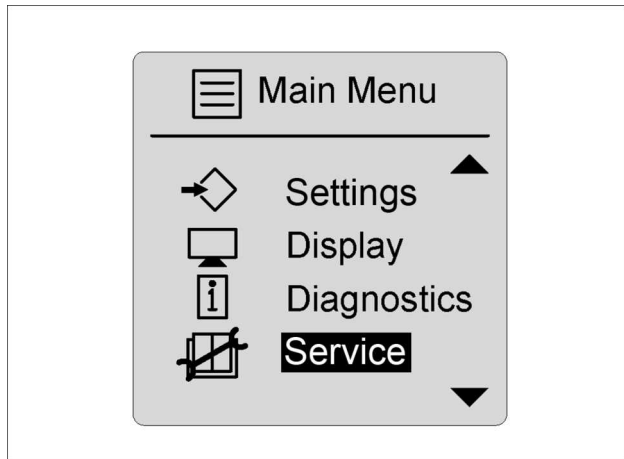

RAIL15DOZ0018AA 22

8. Scroll down, and highlight the "Tow Mode" selection and press the enter switch.

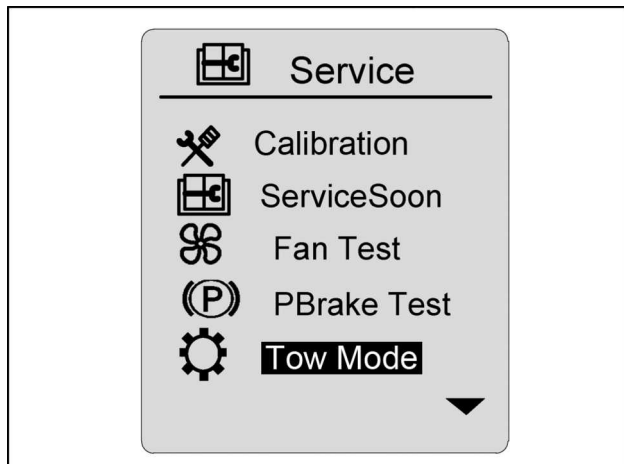

RAIL15DOZ0032AA 23

9. Change the Tow Mode from “Enabled” to “Disabled” by highlighting and pressing the enter switch.

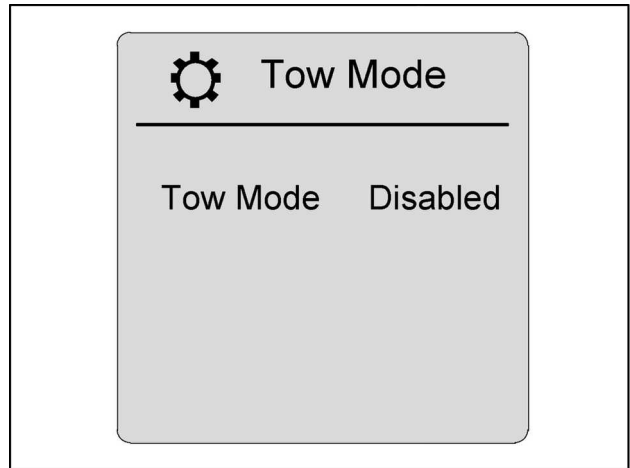

RAIL12DOZ0592AA 24

Hydraulic contamination

2050M

NA

Contamination in the hydraulic system is a major cause of the malfunction of hydraulic components. Contamination is any foreign material in the hydraulic oil. Contamination can enter the hydraulic system in several ways.

- (A) When you drain the oil or disconnect any line.
- (B) When you disassemble a component.
- (C) From normal wear of the hydraulic components.
- (D) From damaged or worn seals.
- (E) From a damaged component in the hydraulic system.

All hydraulic systems operate with some contamination. The design of the components in this hydraulic system permits efficient operation with a small amount of contamination. An increase in this amount of contamination can cause problems in the hydraulic system. The following list includes some of these problems.

- (A) Cylinder rod seals leak.
- (B) Control valve spools do not return to neutral.
- (C) Movement of control valve spools is difficult.
- (D) Hydraulic oil becomes too hot.
- (E) Pump gears, housing, and other parts wear rapidly.
- (F) Relief valves or check valves held open by dirt.
- (G) Quick failure of components that have been repaired.
- (H) Cycle times are slow; machine does not have enough power.

If your machine has any of these problems, check the hydraulic oil for contamination. There are two types of contamination, microscopic and visible.

Microscopic contamination occurs when very fine particles of foreign material are in suspension in the hydraulic oil. These particles are too small to see or feel. Microscopic contamination can be found by identification of the following problems or by testing in a laboratory. Examples of the problems:

- (A) Cylinder rod seal leak.
- (B) Control valve spools do not return to NEUTRAL.
- (C) The hydraulic system has a high operating temperature.

Visible contamination is foreign material that can be found by sight, touch, or odor. Visible contamination can cause a sudden failure of components. Examples of visible contamination:

- (A) Particles of metal or dirt in the oil.
- (B) Air in the oil.
- (C) The oil is dark and thick.
- (D) The oil has an odor of burned oil.
- (E) Water in the oil.

If you find contamination, use a Portable Filter to clean the hydraulic system.

Conversion factors

2050M

NA

Metric to U.S.			
	MULTIPLY	BY	TO OBTAIN
AREA:	square meter	10.763 91	square foot
	hectare	2.471 05	acre
FORCE:	newton	3.596 942	ounce force
	newton	0.224 809	pound force
LENGTH:	millimeter	0.039 370	inch
	meter	3.280 840	foot
	kilometer	0.621 371	mile
MASS:	kilogram	2.204 622	pound
MASS/AREA:	kilogram/hectare	0.000 466	ton/acre
MASS/ENERGY:	gr/kW/hr.	0.001 644	lbs/hp/hr.
MASS/VOLUME:	kg/cubic meter	1.685 555	lb/cubic yd.
POWER:	kilowatt	1.341 02	horsepower
PRESSURE:	kilopascal	0.145 038	lb/sq. inch
	bar	14.50385	lb/sq. inch
TEMPERATURE:	degree C	1.8 x C +32	degree F
TORQUE:	newton meter	8.850 748	lb/inch
	newton meter	0.737 562	lb/foot
VELOCITY:	kilometer/hr.	0.621 371	miles/hr.
VOLUME:	cubic centimeter	0.061 024	cubic inch
	cubic meter	35.314 66	cubic foot
	cubic meter	1.307 950	cubic yd.
	milliliter	0.033 814	ounce (US fluid)
	litre	1.056 814	quart (US liquid)
	litre	0.879 877	quart (Imperial)
	litre	0.264 172	gallon (US liquid)
	litre	0.219 969	gallon (Imperial)
VOLUME/TIME:	litre/min.	0.264 172	gallon/min. (US liquid)
	litre/min.	0.219 969	gallon/min. (Imperial)

U.S. to Metric			
	MULTIPLY	BY	TO OBTAIN
AREA:	square foot	0.092 903	square meter
	acre	0.404 686	hectare
FORCE:	ounce force	0.278 014	newton
	pound force	4.448 222	newton
LENGTH:	inch	25.4 *	millimeter
	foot	0.304 8 *	meter
	mile	1.609 344 *	kilometer
MASS:	pound	0.453 592	kilogram
	ounce	28.35	gram
MASS/AREA:	ton/acre	2241 702	kilogram/hectare
MASS/ENERGY:	lb/hp/hr	608.277 4	gr/kW/hr
MASS/VOLUME:	lb/cubic yd.	0.593 276	kg/cubic meter
POWER:	horsepower	0.745 700	kilowatt
PRESSURE:	lbs/sq. in	6.894 757	kilopascal
	lbs/sq. in	0.069	bar
	lbs/sq. in	0.070 303	kg/sq. cm
TEMPERATURE:	degree F	1.8 F - 32	degree C
TORQUE:	pound/inch	0.112 985	newton meter
	pound/foot	1.355 818	newton meter
VELOCITY:	miles/hr.	1.609 344 *	kilometer/hr.

INTRODUCTION

U.S. to Metric			
	MULTIPLY	BY	TO OBTAIN
VOLUME:	cubic inch	16.387 06	cubic centimeter
	cubic foot	0.028 317	cubic meter
	cubic yard	0.764.555	cubic meter
	ounce (US fluid)	29.573 53	milliliter
	quart (US liquid)	0.946 353	litre
	quart (Imperial)	1.136 523	litre
	gallon (US)	3.785 412	litre
	gallon (Imperial)	4.546 092	litre
VOLUME/TIME:	gallon/min.	3.785 412	litre/min.

Consumables - Loctite® product chart

2050M

NA

Bonding adhesives					
Product	Color	Strength	Fixture/Full Cure (Steel/Steel) Time	Recommended Primer or Activator	Description
312	Clear	9.8 - 17.2 MPa (1421 - 2495 psi)	2 min/24 hrs	736	Typical applications include bonding dissimilar materials such as metals, glass or ceramics and where fast fixturing is required between close fitting parts.
324	Light amber	34 - 614 MPa (4932 - 89061 psi)	30 min/24 hrs	7075	Is used to bond flat parts together. Especially suitable for joining dissimilar materials, e.g. ferrite to plated materials in electric motors, loudspeakers, etc. This product is specifically formulated for toughness and impact strength.
326	Yellow to light amber	34 - 300 MPa (4932 - 43515 psi)	3 min/6 hrs	7649 on one surface	Typical applications include bonding ferrites to plated materials in electric motors, loudspeaker hardware and jewelry where fast fixturing is required.
380	Black	26 MPa (3770 psi)	2 min/24 hrs	none	Is a rubber toughened adhesive with increased flexibility and peel strength along with enhanced resistance to shock.
409	Clear to slightly cloudy	18 - 26 MPa (2611 - 3771 psi)	2 min/24 hrs	none	Is a general purpose cyanoacrylate adhesive gel. The gel consistency prevents adhesive flow even on vertical surfaces.
426	Black	4.8 - 20.7 MPa (696 - 3003 psi)	10 sec/40 sec.	none	Is an adhesive gel toughened with elastomers for impact and peel strength along with improved resistance to heat and humidity.
454	Clear to slightly cloudy	19 - 28 MPa (2756 - 4061 psi)	1 min/72 hrs	none	Is particularly suited for bonding porous or absorbent materials such as wood, paper, leather and fabric.
455	Clear to light yellow	9.7 MPa (1407 psi)	30 sec/24 hrs	none	Is a general purpose cyanoacrylate adhesive gel with low odor and low blooming properties and is particularly suitable for applications where vapor control is difficult.
480	Black	22 - 30 MPa (3191 - 4352 psi)	2 min/24 hrs	none	Is a rubber toughened adhesive with increased flexibility and peel strength along with enhanced resistance to shock.
495	Clear to straw colored	12 - 26 MPa (1741 - 3771 psi)	10 sec/30 sec.	none	Is a general purpose cyanoacrylate instant adhesive.
E60HP	Pale yellow	29.8 MPa (4322 psi)	3 hrs/24 hrs	none	Is a toughened, medium viscosity, industrial grade epoxy adhesive with extended work life. Once mixed, the two-component epoxy cures at room temperature to form a tough, off-white, bond line which provides high peel resistance and high shear strengths. The fully cured epoxy is resistant to a wide range of chemicals and solvents, and acts as an excellent electrical insulator.

INTRODUCTION

Surface preparation			
Product	Color	Active (Steel/Steel) Time	Description
7380	Yellow to light amber	6 hours	Is designed to initiate the cure of Loctite toughened acrylic adhesives.
7471	Yellow to light amber	30 to 70 seconds	Is used where increased cure speed of LOCTITE® anaerobic products is required. It is especially recommended for applications with passive metals or inert surfaces and with large bond gaps. Is particularly recommended when prevailing temperature is low < 15 °C (60 °F) .
7649	Green	30 to 70 seconds	Is used where increased cure speed of LOCTITE® anaerobic products is required. It is especially recommended for applications with passive metals or inert surfaces and with large bond gaps. Is particularly recommended when prevailing temperature is low < 15 °C (60 °F) .

Retain, cylindrical assemblies					
Product	Color	Strength	Fixture/Full Cure (Steel/Steel) Time	Recommended Primer or Activator	Description
603	Green	13.5 - 22.5 MPa (1958 - 3264 psi)	7 min/6 hrs	7471 or 7469	Is designed for the bonding of cylindrical fitting parts, particularly where consistently clean surfaces cannot be assured. The product cures when confined in the absence of air between close fitting metal surfaces and prevents loosening and leakage from shock and vibration. Typical applications include retaining roller bearings or oil impregnated bushings into housings.
609	Green	10.3 - 15.8 MPa (1494 - 2292 psi)	25 min/6 hrs	7471 or 7469	Is designed for the bonding of cylindrical fitting parts. The product cures when confined in the absence of air between close fitting metal surfaces and prevents loosening and leakage from shock and vibration. Typical applications include rotor to shafts in fractional and subfractional horsepower motors. Locks bushings and sleeves in housings on shafts. Augments press fits.
620	Green	17.2 - 24.1 MPa (2495 - 3496 psi)	1 hr 10 min/18 hrs	7471 or 7469	Is designed for the bonding of cylindrical fitting parts. The product cures when confined in the absence of air between close fitting metal surfaces and prevents loosening and leakage from shock and vibration. Typical applications include locating pins in radiator assemblies, sleeves into pump housings and bearings in auto transmissions. Particularly suitable for applications where temperature resistance up to 200 °C (395 °F) is required.
635	Green opaque	13.8 - 31.0 MPa (2002 - 4497 psi)	30 min/72 hrs	7471 or 7469	Is designed for the bonding of cylindrical fitting parts. The product cures when confined in the absence of air between close fitting metal surfaces and prevents loosening and leakage from shock and vibration. Typical applications include rotor to shafts in fractional and subfractional horsepower motors. Locks bushings and sleeves in housings on shafts. Augments press fits.

INTRODUCTION

Retain, cylindrical assemblies					
Product	Color	Strength	Fixture/Full Cure (Steel/Steel) Time	Recommended Primer or Activator	Description
638	Green	13.5 - 25.0 MPa (1958 - 3626 psi)	4 min/6 hrs	7471 or 7469	Is designed for the bonding of cylindrical fitting parts, particularly where bond gaps can approach 0.25 mm (0.01 in.) and where maximum strength at room temperature is required. The product cures when confined in the absence of air between close fitting metal surfaces and prevents loosening and leakage from shock and vibration. Typical applications include locking bushings and sleeves into housings and on shafts.
648	Green	13.5 - 25.0 MPa (1958 - 3626 psi)	4 min/1.5 hrs	7471 or 7469	Is designed for the bonding of cylindrical fitting parts. The product cures when confined in the absence of air between close fitting metal surfaces and prevents loosening and leakage from shock and vibration. Typical applications include holding gears and sprockets onto gearbox shafts and rotors on electric motor shafts.
660	Metallic grey	17.2 MPa (2495 psi)	15 min/1.5 hrs	7471 or 7469	Is designed for the bonding of cylindrical fitting parts, particularly where bond gaps can approach 0.50 mm (0.02 in.). The product cures when confined in the absence of air between close fitting metal surfaces and prevents loosening and leakage from shock and vibration. This product possesses excellent gap cure characteristics. Typical applications include restoring correct fits on worn shafts, spun bearings, and damaged keyways.
680	Green	19.3 - 24.1 MPa (2799 - 3496 psi)	20 min/1.1 hrs	7471 or 7469	Is designed for the bonding of cylindrical fitting parts, particularly where low viscosity is required. The product cures when confined in the absence of air between close fitting metal surfaces and prevents loosening and leakage from shock and vibration.

RTV sealants					
Product	Color	Strength	Fixture/Full Cure (Steel/Steel) Time	Description	
5699	Grey	1.3 - 2.1 MPa (189 - 305 psi)	30 min/14 days	Is designed primarily for flange sealing with excellent oil resistance on rigid flange sealing for example on transmissions and cast metal housings.	
587	Blue	NA	2 hrs/24 hrs	Forms tough, flexible gaskets directly on the flange. Sensor-safe, low odor, non-corrosive. Excellent oil resistance and joint movement values. Eight times more flexible than cork/composite gaskets; three times more oil resistant than conventional silicones. Temperature range -59 - 260 °C (-75 - 500 °F) intermittent; resists auto and shop fluids.	
593	Black	1.5 MPa (218 psi)	5 min/24 hrs	Is designed for superior bonding and sealing properties to most surfaces (not recommended for concrete). This product resists aging, weathering and thermal cycling without hardening, shrinking or cracking. It is formulated to withstand extreme temperature cycling, UV light and ozone. The thixotropic nature reduces the migration of liquid product after application to the substrate.	

INTRODUCTION

RTV sealants				
Product	Color	Strength	Fixture/Full Cure (Steel/Steel) Time	Description
595	Clear	1.5 MPa (218 psi)	5 min/24 hrs	Is designed for superior bonding and sealing properties to most surfaces (not recommended for concrete). This product resists aging, weathering and thermal cycling without hardening, shrinking or cracking. It is formulated to withstand extreme temperature cycling, UV light and ozone. The thixotropic nature reduces the migration of liquid product after application to the substrate.
596	Red	NA	5 min/24 hrs	Is specifically formulated for gasketing and sealing where high temperatures 315 °C (600 °F) are experienced such as exhaust manifolds - crossovers, high temperature ovens and furnaces. Applications where sealing and bonding are required under frequent exposure to temperatures above 235 - 315 °C (450 - 600 °F) .

Gasket sealants					
Product	Color	Strength	Fixture/Full Cure (Steel/Steel) Time	Recommended Primer or Activator	Description
509	Blue to greenish paste	8 - 9 MPa (1160 - 1305 psi)	1 hr/72 hrs	7471 or 7469	Provides resistance to low pressures immediately after assembly of flanges. It seals close fitting joints between rigid metal faces and flanges. Typically used as a form-in-place gasket on rigid flanged connections, e.g. gearbox and engine casings, etc. The thixotropic nature reduces the migration of liquid product after application to the substrate.
515	Opaque, dark purple	6 - 14 MPa (870 - 2031 psi)	30 min/18 hrs	7471 or 7469	It seals close fitting joints between rigid metal faces and flanges and will flex with minor flange movements. Provides resistance to low pressures immediately after assembly of flanges. Typically used as a form-in-place gasket for pumps, thermostats, compressors, transmission housings and axle covers.
518	Red	7.5 - 8.5 MPa (1088 - 1233 psi)	30 min/8 hrs	7471 or 7469	Typical applications include sealing close fitting joints between rigid metal faces and flanges. Provides resistance to low pressures immediately after assembly of flanges. Typically used as a form-in-place gasket on rigid flanged connections, e.g. gearbox and engine casings, etc.
542	Brown	9 - 25 Nm (80 - 222 lb in)	20 min/8 hrs	7471 or 7469	Is designed for the locking and sealing of metal pipes and fittings. The product cures when confined in the absence of air between close fitting metal surfaces and prevents loosening and leakage from shock and vibration.
545	Purple	2 Nm (20 lb in)	30 min/24 hrs	7471 or 7469	Is designed for the locking and sealing of metal pipes and fittings. The product cures when confined in the absence of air between close fitting metal surfaces and prevents loosening and leakage from shock and vibration. This product is specially formulated to offer lubricity for easy assembly.
567	Off white	0.3 - 1.7 Nm (3 - 15 lb in)	4 hrs/72 hrs	7471 or 7469	Is designed for the locking and sealing of metal tapered threads and fittings.
569	Brown	1.1 - 2.8 Nm (10 - 25 lb in)	2 hr/24 hrs	7471 or 7469	Is designed for the locking and sealing of plastic and metal pipes and fittings.

INTRODUCTION

Gasket sealants					
Product	Color	Strength	Fixture/Full Cure (Steel/Steel) Time	Recommended Primer or Activator	Description
592	White	0.113 - 0.330 Nm (1 - 3 lb in)	72 hrs	none	Is a medium strength anaerobic sealant with Teflon® for tapered pipe threads. The high lubricating properties of this compound prevent galling on pipe threads and fittings. It will provide immediate low pressure sealing and allow the readjustment of fittings shortly after assembly. After 72 hours the joint is sealed to pipe burst pressure.
598	Metallic black	1.31 MPa (190 psi)	25 min/72 hrs	none	This product resists aging, weathering and thermal cycling without hardening, shrinking or cracking. Typical applications include oil pans, transmission pans, valve covers, valves and guides, timing gear covers, and differential covers. This product is typically used in applications with an operating range of -54 - 260 °C (-65 - 500 °F) .

Thread locker and sealing					
Product	Color	Strength	Fixture/Full Cure (Steel/Steel) Time	Recommended Primer or Activator	Description
204	Pink	12.4 - 24.9 Nm (110 - 220 lb in)	10 min/72 hrs	none	Is a dry-to-the-touch, preapplied film for threaded fasteners. It remains inert on the fastener until assembly of the threads releases a quick curing resin. The resin fills all the voids in the threads and cures to securely lock and seal the assembly.
222	Purple	4 - 14 Nm (35 - 124 lb in)	20 min/3 hrs	7471 or 7469	Is designed for the locking and sealing of threaded fasteners which require easy disassembly with standard hand tools.
242	Blue	5.6 - 17 Nm (50 - 150 lb in)	3 min/6 hrs	7471 or 7469	Is designed for the locking and sealing of threaded fasteners which require normal disassembly with standard hand tools.
243	Blue	7 - 24 Nm (62 - 212 lb in)	10 min/1 hr	7471 or 7469	Is designed for the locking and sealing of threaded fasteners which require normal disassembly with standard hand tools.
246	Blue	2 - 5.7 Nm (18 - 50 lb in)	10 min/6 hrs	7471 or 7469	Is designed for the locking and sealing of threaded fasteners which require normal disassembly with standard hand tools. The product cures when confined in the absence of air between close fitting metal surfaces and prevents loosening and leakage from shock and vibration. Particularly suitable for heavy duty applications such as bolts used in transmissions, construction equipment or railroad assemblies where resistance to heavy shock, vibration and stress level is required along with exposure to elevated temperatures.
262	Red	22 - 40 Nm (195 - 354 lb in)	15min/7 hrs	7471 or 7469	Is designed for the permanent locking and sealing of threaded fasteners.
271	Red	16.9 - 34 Nm (150 - 300 lb in)	10 min/24 hrs	7471 or 7469	Is designed for the permanent locking and sealing of threaded fasteners.
277	Red	32 - 40 Nm (283 - 354 lb in)	30 min/7 hrs	7471 or 7469	Is designed for the permanent locking and sealing of threaded fasteners.

INTRODUCTION

Thread locker and sealing					
Product	Color	Strength	Fixture/Full Cure (Steel/Steel) Time	Recommended Primer or Activator	Description
290	Green	10 - 40 Nm (90 - 355 lb in)	20 min/4 hrs	7471 or 7469	Is designed for the locking and sealing of threaded fasteners. Because of its low viscosity and capillary action, the product wicks between engaged threads and eliminates the need to disassemble prior to application.
425	Dark blue	0.23 - 8.5 Nm (2 - 75 lb in)	2 min/24 hrs	7113	Is designed as a fast curing, low strength adhesive for locking metal and plastics fasteners. The product is designed for pre- or post-application. LOCTITE® 425™ cures quickly on plated metal and plastics fasteners; fixturing is achieved in less than 2 minutes and full strength within 24 hours.

Capacities

2050M	NA
-------	----

Fluids and lubricants

Engine crankcase	
Capacity with filter change	16.4 L (17.3 US qt)
Capacity without filter change	15.6 L (16.5 US qt)
Specifications	CASE AKCELA UNITEK NO. 1™ SBL CJ-4 SAE 10W-40
Fuel tank	
Capacity	405 L (107 US gal)
Selective Catalytic Reduction System — DEF/AdBLUE®	
Capacity	52 L (14 US gal)
Cooling system	
Capacity	30.28 L (8.0 US gal)
Specifications	50 % Water and 50 % CNH XHD HEAVY DUTY COOLANT / ANTI-FREEZE or CASE AKCELA ACTIFULL™ OT EXTENDED LIFE COOLANT. Depending on the date of manufacture, the machine could have either coolant type. Machines with OAT coolant will have a decal near the fill location. Never mix conventional coolant with OAT coolant. See Engine cooling system - Basic instructions (10.400) for instructions on switching coolant types.
Hydraulic reservoir/Transmission refill	
Capacity	210 L (55 US gal)
Specifications	TUTELA AUTO SUPREME™ ENGINE OIL SAE 10W-30
Final drives	
Capacity - Each Side	25.0 L (26.4 US qt)
Specifications	CASE AKCELA GEAR 135 H EP 85W-140
Grease fittings	
Quantity	As Required
Specifications	TUTELA MOLY GREASE GR-75

NOTE: If the ambient temperature is lower than **-37 °C (-34.6 °F)**, adjust the mixture according to the coolant manufacturer specifications.

Coolant solution

Use only **CNH XHD HEAVY DUTY COOLANT / ANTI-FREEZE** or **CASE AKCELA ACTIFULL™ OT EXTENDED LIFE COOLANT** solution in the cooling system with no additives to prevent leakage. Do not use non-approved anti-rust additives.

NOTICE: *Anti-rust additives and ethylene-glycol can mix and work against each other, reducing anti-corrosion protection, forming deposits in the cooling system, and causing damage to the cooling system and radiator. Contact your dealer for a suitable coolant solution.*

Anti-freeze/Anti-corrosion

Use anti-freeze in all seasons to protect the cooling system from corrosion and risk of freezing. For areas where the ambient temperature is over **-36 °C (-32.8 °F)**, use a blend of **50 %** ethylene-glycol based anti-freeze.

For areas where the temperature is below **-36 °C (-32.8 °F)**, it is advisable to use a blend of **40 %** water and **60 %** anti-freeze.

Fuel

Use diesel fuel suitable for the ambient temperature conditions.

Use fuel which is to American Society for Testing and Materials **ASTM D975** standard.

Use grade No. 2 fuel. The use of other types of fuel can result in a loss of power of the engine and may cause high fuel consumption.

In very low ambient temperatures, use a mixture of fuels No. 1 and No. 2 as necessary. Consult your fuel supplier for appropriate fuel supply.

If the temperature falls below the fuel cloud point (point at which wax begins to form), the wax crystals will cause power loss or will prevent the engine from starting.

In cold weather, fill the fuel tank at the end of the day's work in order to prevent the formation of condensation.

Fuel storage

Prolonged storage of fuel can lead to the accumulation of impurities and condensation in the fuel. Engine problems can often be traced to the presence of water in the fuel.

The storage tank must be placed outside, and the temperature of the fuel should be kept as low as possible. Drain off water and impurities regularly.

Engine oil

CASE AKCELA UNITEK NO. 1™ SBL CJ-4 SAE 10W-40 is recommended for your engine. This oil insures correct lubrication of your engine in all working conditions. See charts at the beginning of this section to choose the correct oil for climate/temperatures.

If **CASE AKCELA UNITEK NO. 1™ SBL CJ-4 SAE 10W-40** cannot be obtained, use only oil of the API SERVICE CJ-4 category.

NOTE: *Do not put any performance additive or other additive in the sump. Oil change intervals shown in this manual are based on tests carried out utilizing CNH lubricants.*

Hydraulic fluid

TUTELA AUTO SUPREME™ ENGINE OIL SAE 10W-30 is specifically designed for high pressure applications and for this machine's hydraulic system. Your authorized dealer can provide hydraulic fluid to fulfill different climate/temperature conditions.

Final drive oil

Use **CASE AKCELA GEAR 135 H EP 85W-140** when replacing or adding fluid to the final drive for this machine.

Grease

The type of grease to use depends on ambient temperature such as **TUTELA MOLY GREASE GR-75**.

Environment

Before you service this machine and dispose of oil, fluids, and lubricants, obey environmental regulations. Do not drain oil or fluids on to the ground or into containers that leak. Check with your local environmental recycling center or your dealer for correct disposal information.

Product identification

2050M	NA
-------	----

Model, serial number, and year of manufacture

Record the machine and Product Identification Number (PIN). When ordering parts, obtaining information or assistance, always supply your dealer with the type and PIN of your machine or accessories. Keep a record of these numbers and your Manufacturer's Statement of Origin in a safe place. If the machine is stolen, report the numbers to your local law enforcement agency.

Machine identification

Model name

Product Identification Number (PIN)

Model year

The PIN plate is located on the left side of the machine in front of the engine access door.

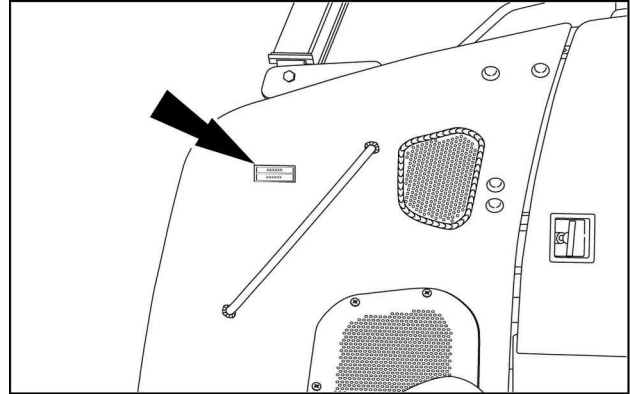

RAPH12DOZ0131AA 1

Roll Over Protective Structure (ROPS)

The ROPS serial number plate is located in the left rear access compartment.

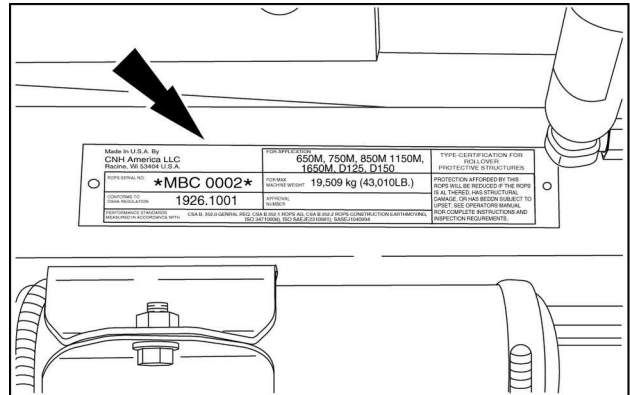

RAPH12DOZ0045AA 2

Engine make and model

Engine serial number

The serial number plate is on the engine valve cover.

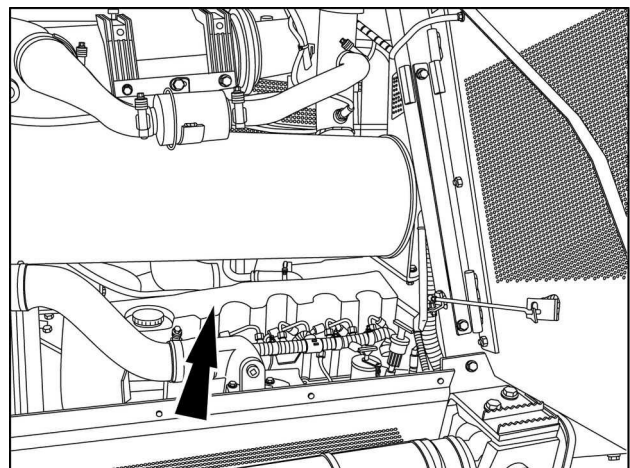

RAIL13DOZ1693AA 3

Dozer blade

The serial number plate is on the right side of the dozer blade.

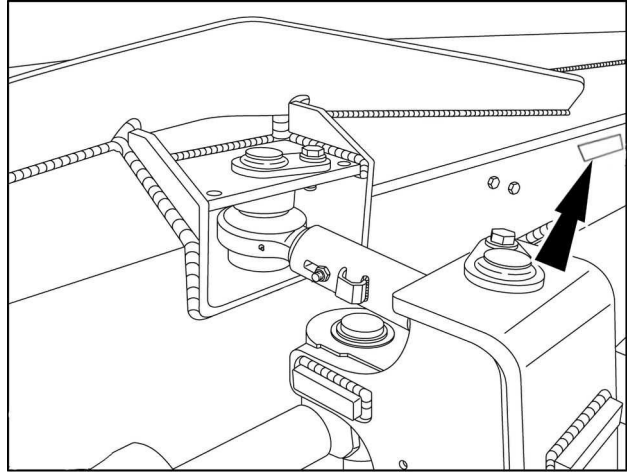

RAIL13DOZ1609AA 4

Product identification - Machine orientation

2050M

NA

The terms right-hand, left-hand, front, and rear are used in this manual to indicate the sides as they are seen from the operator's seat.

1. Front
2. Right
3. Rear
4. Left

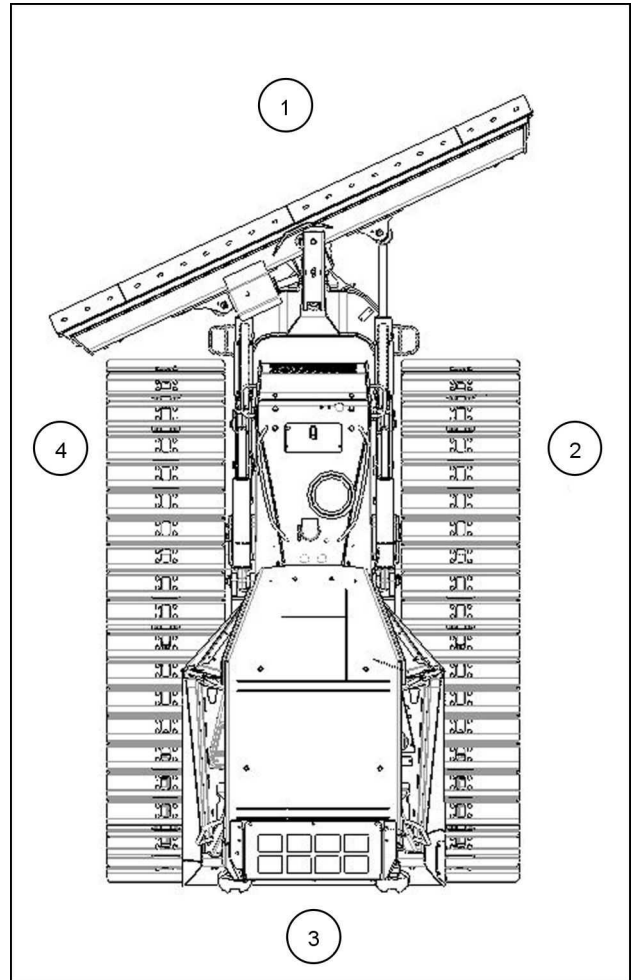

RAPH13DOZ0888CA 1



SERVICE MANUAL

Engine

2050M Extended Long Track (XLT), Bulldozer (BD) Blade [NCDC25000 -] ,
2050M Extended Long Track (XLT), Bulldozer (BD) Blade [NDDC25000 -] ,
2050M Extended Long Track (XLT), Bulldozer (BD) Blade [NEDC20000 -]
 , 2050M Extended Long Track (XLT), Bulldozer (BD) Blade [NFDC20000 -] ,
2050M Extra Long Track (XLT), Power Angle Tilt (PAT) Blade [NCDC25000 -] ,
2050M Extra Long Track (XLT), Power Angle Tilt (PAT) Blade [NDDC25000 -] ,
2050M Extra Long Track (XLT), Power Angle Tilt (PAT) Blade [NEDC20000 -]
 , 2050M Extra Long Track (XLT), Power Angle Tilt (PAT) Blade [NFDC20000
 -] , 2050M Long Track (LT), Bulldozer (BD) Blade [NCDC25000 -] , 2050M
Long Track (LT), Bulldozer (BD) Blade [NDDC25000 -] , 2050M Long Track
(LT), Bulldozer (BD) Blade [NEDC20000 -] , 2050M Long Track (LT), Bulldozer
(BD) Blade [NFDC20000 -] , 2050M Long Track (LT), Power Angle Tilt (PAT)
Blade [NCDC25000 -] , 2050M Long Track (LT), Power Angle Tilt (PAT) Blade
 [NDDC25000 -] , 2050M Long Track (LT), Power Angle Tilt (PAT) Blade
 [NEDC20000 -] , 2050M Long Track (LT), Power Angle Tilt (PAT) Blade
 [NFDC20000 -] , 2050M Wide Track (WT) / Low Ground Pressure (LGP),
Bulldozer (BD) Blade [NCDC25000 -] , 2050M Wide Track (WT) / Low Ground
Pressure (LGP), Bulldozer (BD) Blade [NDDC25000 -] , 2050M Wide Track
(WT) / Low Ground Pressure (LGP), Bulldozer (BD) Blade [NEDC20000 -] ,
2050M Wide Track (WT) / Low Ground Pressure (LGP), Bulldozer (BD) Blade
 [NFDC20000 -] , 2050M Wide Track (WT) / Low Ground Pressure (LGP),
Power Angle Tilt (PAT) Blade [NCDC25000 -] , 2050M Wide Track (WT) / Low
Ground Pressure (LGP), Power Angle Tilt (PAT) Blade [NDDC25000 -] , 2050M
Wide Track (WT) / Low Ground Pressure (LGP), Power Angle Tilt (PAT) Blade
 [NEDC20000 -] , 2050M Wide Track (WT) / Low Ground Pressure (LGP),
Power Angle Tilt (PAT) Blade [NFDC20000 -]

Contents

Engine - 10

[10.001] Engine and crankcase	10.1
[10.216] Fuel tanks	10.2
[10.206] Fuel filters	10.3
[10.202] Air cleaners and lines	10.4
[10.250] Turbocharger and lines	10.5
[10.500] Selective Catalytic Reduction (SCR) exhaust treatment	10.6
[10.400] Engine cooling system	10.7
[10.414] Fan and drive	10.8
[10.310] Aftercooler	10.9
[10.304] Engine lubrication system	10.10

This as a preview PDF file from best-manuals.com



Download full PDF manual at best-manuals.com