

Shop Manual

PC290LL-11

LOG LOADER ROAD BUILDER

SERIAL NUMBERS **PC290LL-11 A29501 and up**

ENGINE **6D107E-3**

This material is proprietary to Komatsu America Corp. and is not to be reproduced, used, or disclosed except in accordance with written authorization from Komatsu America Corp.

It is our policy to improve our products whenever it is possible and practical to do so. We reserve the right to make changes or improvements at any time without incurring any obligation to install such changes on products sold previously.

Due to this continuous program of research and development, revisions may be made to this publication. It is recommended that customers contact their distributor for information on the latest revision.

Copyright 2018 Komatsu
Printed in U.S.A.
Komatsu America Corp.

00 INDEX AND FOREWORD

INDEX

00 INDEX AND FOREWORD	00-1
ABBREVIATION LIST	00-19
FOREWORD, SAFETY, BASIC INFORMATION	00-24
HOW TO READ THE SHOP MANUAL	00-24
SAFETY NOTICE FOR OPERATION	00-26
PRECAUTIONS TO PREVENT FIRE	00-34
ACTIONS IF FIRE OCCURS	00-36
PRECAUTIONS FOR CAB TILTING	00-37
PRECAUTIONS FOR DISPOSING OF WASTE MATERIALS	00-38
ACTIONS TAKEN TO MEET EXHAUST GAS REGULATIONS	00-39
PRECAUTIONS FOR DEF	00-40
STORE DEF	00-41
PRECAUTIONS FOR HANDLING HYDRAULIC EQUIPMENT	00-42
PRECAUTIONS FOR DISCONNECTION AND CONNECTION OF PIPINGS	00-44
PRECAUTIONS FOR HANDLING ELECTRICAL EQUIPMENT	00-50
PRECAUTIONS FOR HANDLING FUEL SYSTEM EQUIPMENT	00-52
PRECAUTIONS FOR HANDLING INTAKE SYSTEM EQUIPMENT	00-53
PRACTICAL USE OF KOMTRAX	00-54
DISCONNECT AND CONNECT PUSH-PULL TYPE COUPLER	00-55
PRECAUTIONS FOR DISCONNECTION AND CONNECTION OF CONNECTORS	00-59
METHOD FOR DISCONNECTING AND CONNECTING DEUTSCH CONNECTOR	00-63
METHOD FOR DISCONNECTING AND CONNECTING SLIDE LOCK TYPE CONNECTOR	00-64
METHOD FOR DISCONNECTING AND CONNECTING CONNECTOR WITH LOCK TO PULL ..	00-66
METHOD FOR DISCONNECTING AND CONNECTING CONNECTOR WITH LOCK TO PUSH ..	00-67
METHOD FOR DISCONNECTING AND CONNECTING CONNECTOR WITH HOUSING TO ROTATE .	00-69
HOW TO READ ELECTRICAL WIRE CODE	00-70
EXPLANATION OF TERMS FOR MAINTENANCE STANDARD	00-74
STANDARD TIGHTENING TORQUE TABLE	00-77
CONVERSION TABLE	00-84
01 SPECIFICATIONS	01-1
CONTENTS	01-2
ABBREVIATION LIST	01-3
SPECIFICATIONS	01-8
SPECIFICATION DRAWING	01-8
WORKING RANGE DRAWINGS	01-11
SPECIFICATIONS	01-14
WEIGHT TABLE	01-18
TABLE OF FUEL, COOLANT, AND LUBRICANTS	01-20
10 STRUCTURE AND FUNCTION	10-1
CONTENTS	10-2
ABBREVIATION LIST	10-5
UREA SCR SYSTEM	10-10
LAYOUT DRAWING OF UREA SCR SYSTEM	10-11
UREA SCR SYSTEM DIAGRAM	10-16
FUNCTION OF UREA SCR SYSTEM	10-17
COMPONENT PARTS OF UREA SCR SYSTEM	10-25
BOOT-UP SYSTEM	10-34
LAYOUT DRAWING OF BOOT-UP SYSTEM	10-34
SYSTEM OPERATING LAMP SYSTEM	10-36
BATTERY DISCONNECT SWITCH	10-37
ENGINE SYSTEM	10-38
LAYOUT DRAWING OF ENGINE SYSTEM	10-38
ENGINE CONTROL SYSTEM	10-40
AUTO-DECELERATION SYSTEM	10-43
ENGINE AUTOMATIC WARM-UP SYSTEM	10-45

OVERHEAT PREVENTION SYSTEM	10-47
TURBOCHARGER PROTECTION SYSTEM	10-50
AUTOMATIC IDLE STOP SYSTEM	10-52
COMPONENT PARTS OF ENGINE SYSTEM	10-55
COOLING SYSTEM	10-73
LAYOUT DRAWING OF COOLING SYSTEM	10-73
CONTROL SYSTEM	10-75
LAYOUT DRAWING OF CONTROL SYSTEM	10-75
MACHINE MONITOR SYSTEM	10-78
KOMTRAX SYSTEM	10-79
COMPONENT PARTS OF CONTROL SYSTEM	10-80
HYDRAULIC SYSTEM	10-111
LAYOUT DRAWING OF HYDRAULIC SYSTEM	10-111
CLSS	10-117
ENGINE AND PUMP COMBINED CONTROL SYSTEM	10-135
PUMP AND VALVE CONTROL SYSTEM	10-141
COMPONENT PARTS OF HYDRAULIC SYSTEM	10-144
WORK EQUIPMENT SYSTEM	10-234
LAYOUT DRAWING OF WORK EQUIPMENT SYSTEM (ROAD BUILDER)	10-234
LAYOUT DRAWING OF WORK EQUIPMENT SYSTEM (LOG LOADER)	10-235
LAYOUT DRAWING OF WORK EQUIPMENT SYSTEM DETAIL	10-236
STRUCTURE OF VALVE CONTROL	10-240
PPC LEVERS	10-242
ONE-TOUCH POWER MAXIMIZING SYSTEM	10-244
PPC LOCK SYSTEM	10-246
WORK EQUIPMENT AND TRAVEL AUTOMATIC LOCK SYSTEM	10-247
OIL FLOW ADJUSTER SYSTEM FOR ATTACHMENT	10-249
COMPONENT PARTS OF WORK EQUIPMENT SYSTEM	10-251
SWING SYSTEM	10-267
LAYOUT DRAWING OF SWING SYSTEM	10-267
SWING CONTROL SYSTEM DIAGRAM	10-271
COMPONENT PARTS OF SWING SYSTEM	10-277
TRAVEL SYSTEM	10-291
LAYOUT DRAWING OF TRAVEL SYSTEM	10-291
TRAVEL CONTROL SYSTEM DIAGRAM	10-295
COMPONENT PARTS OF TRAVEL SYSTEM	10-297
UNDERCARRIAGE AND FRAME	10-317
TRACK FRAME AND IDLER CUSHION	10-317
SPECIFICATIONS OF UNDERCARRIAGE	10-319
WORK EQUIPMENT	10-320
STRUCTURE OF WORK EQUIPMENT (ROAD BUILDER)	10-320
FUNCTION OF WORK EQUIPMENT (ROAD BUILDER)	10-321
STRUCTURE OF WORK EQUIPMENT (LOG LOADER)	10-322
FUNCTION OF WORK EQUIPMENT (LOG LOADER)	10-323
WORK EQUIPMENT CLEARANCE ADJUSTMENT SHIM	10-324
BUCKET CLEARANCE ADJUSTMENT SHIM	10-325
CAB AND ITS ATTACHMENTS	10-326
CAB STRUCTURE	10-326
20 STANDARD VALUE TABLE	20-1
CONTENTS	20-2
ABBREVIATION LIST	20-3
STANDARD VALUE TABLE FOR ENGINE	20-8
STANDARD VALUE TABLE FOR ENGINE: PC290LL-11	20-8
STANDARD VALUE TABLE FOR MACHINE	20-12
STANDARD VALUE TABLE FOR MACHINE: PC290LL-11	20-12
POSTURE OF MACHINE FOR MEASURING PERFORMANCE AND MEASUREMENT PROCEDURE	20-25
STANDARD VALUE TABLE FOR ELECTRICAL	20-31

STANDARD VALUE TABLE FOR ELECTRICAL	20-31
30 TESTING AND ADJUSTING	30-1
CONTENTS	30-2
ABBREVIATION LIST	30-5
RELATED INFORMATION ON TESTING AND ADJUSTING	30-10
TOOLS FOR TESTING AND ADJUSTING.....	30-10
SKETCH OF TOOLS FOR TESTING AND ADJUSTING	30-16
ENGINE AND COOLING SYSTEM.....	30-18
TEST ENGINE SPEED	30-18
TEST BOOST PRESSURE	30-21
TEST EXHAUST GAS COLOR.....	30-23
TEST AND ADJUST VALVE CLEARANCE	30-26
TEST COMPRESSION PRESSURE.....	30-28
TEST BLOWBY PRESSURE	30-33
TEST ENGINE OIL PRESSURE.....	30-35
TEST EGR VALVE AND KVGT OIL PRESSURE	30-36
TEST FUEL PRESSURE	30-38
TEST FUEL DISCHARGE, RETURN AND LEAKAGE	30-44
BLEEDING AIR FROM FUEL SYSTEM	30-50
TEST FUEL CIRCUIT FOR LEAKAGE	30-51
HANDLE CYLINDER CUT-OUT MODE OPERATION.....	30-53
HANDLE NO-INJECTION CRANKING OPERATION	30-54
TEST AND ADJUST AIR CONDITIONER COMPRESSOR BELT TENSION	30-55
WRITING CORRECTION FOR ASH IN SOOT ACCUMULATION TO ENGINE CONTROLLER	30-57
TEST SCR RELATED FUNCTIONS.....	30-58
CLEAN DEF TANK.....	30-80
BLEED AIR FROM COOLANT CIRCUIT OF DEF TANK	30-84
POWER TRAIN.....	30-86
TEST SWING CIRCLE BEARING CLEARANCE	30-86
UNDERCARRIAGE AND FRAME.....	30-88
TEST AND ADJUST TRACK TENSION.....	30-88
HYDRAULIC SYSTEM.....	30-90
RELEASE REMAINING PRESSURE FROM HYDRAULIC SYSTEM.....	30-90
TEST AND ADJUST OIL PRESSURE IN WORK EQUIPMENT, SWING, AND TRAVEL CIRCUITS.....	30-91
TEST OIL PRESSURE OF CONTROL CIRCUIT	30-101
TEST AND ADJUST OIL PRESSURE IN PUMP PC CONTROL CIRCUIT	30-103
TEST AND ADJUST OIL PRESSURE IN PUMP LS CONTROL CIRCUIT.....	30-106
TEST OUTLET PRESSURE OF SOLENOID VALVE	30-113
TEST PPC VALVE OUTLET PRESSURE	30-117
ADJUST WORK EQUIPMENT AND SWING PPC VALVES	30-119
TEST PUMP SWASH PLATE SENSOR.....	30-120
TEST THE PARTS CAUSING HYDRAULIC DRIFT IN WORK EQUIPMENT.....	30-121
TEST OIL LEAKAGE	30-123
BLEED AIR FROM HYDRAULIC CIRCUIT	30-127
MIRROR ADJUSTMENTS	30-130
METHOD FOR ADJUSTING MIRRORS	30-130
ELECTRICAL SYSTEM	30-134
SET AND OPERATE MACHINE MONITOR.....	30-134
METHOD FOR STARTING UP KOMTRAX TERMINAL	30-210
ADJUST REARVIEW CAMERA ANGLE	30-215
HANDLE VOLTAGE CIRCUIT OF ENGINE CONTROLLER	30-218
HANDLE BATTERY DISCONNECT SWITCH	30-219
TEST DIODES	30-220
Pm CLINIC.....	30-221
Pm CLINIC SERVICE	30-221
40 TROUBLESHOOTING	40-1
CONTENTS	40-2

ABBREVIATION LIST	40-12
RELATED INFORMATION ON TROUBLESHOOTING	40-17
GENERAL TROUBLESHOOTING POINTS	40-17
TROUBLESHOOTING POINTS FOR UREA SCR SYSTEM	40-19
SEQUENCE OF EVENTS IN TROUBLESHOOTING	40-31
CHECKS BEFORE TROUBLESHOOTING	40-33
INSPECTION PROCEDURE BEFORE TROUBLESHOOTING	40-35
TESTING IN ACCORDANCE WITH TESTING PROCEDURE	40-37
ELECTRICAL SYSTEM TROUBLESHOOTING - PREPARATION	40-61
PROCEDURE FOR TESTING AND TROUBLESHOOTING	40-71
SYMPTOMS OF FAILURE AND TROUBLESHOOTING NUMBERS	40-74
INFORMATION DESCRIBED IN TROUBLESHOOTING TABLE	40-78
TROUBLESHOOTING METHOD FOR OPEN CIRCUIT IN WIRING HARNESS OF PRESSURE SENSOR SYSTEM	40-80
CONNECTOR LIST AND LAYOUT	40-83
CONNECTOR CONTACT IDENTIFICATION	40-97
T-BRANCH BOX AND T-BRANCH ADAPTER TABLE	40-137
FUSE LOCATION TABLE	40-143
PRECAUTIONS FOR CLEANING AND REPLACING KDPF (KCSF and KDOC)	40-146
PREPARATION OF SHORT CIRCUIT ELECTRICAL CONNECTOR (FOR FAILURE CODES [CA1883] AND [CA3135])	40-150
FAILURE CODES TABLE	40-152
TROUBLESHOOTING BY FAILURE CODE (DISPLAY OF CODE)	40-169
FAILURE CODE [879AKA] A/C Recirculation Air Temperature Sensor Open Circuit	40-169
FAILURE CODE [879AKB] A/C Recirculation Air Temperature Sensor Short Circuit	40-170
FAILURE CODE [879BKA] A/C Fresh Air Temperature Sensor Open Circuit	40-171
FAILURE CODE [879BKB] A/C Fresh Air Temperature Sensor Short Circuit	40-173
FAILURE CODE [879CKA] Ventilating Sensor Open Circuit	40-175
FAILURE CODE [879CKB] Ventilating Sensor Short Circuit	40-176
FAILURE CODE [879DKZ] Sunlight Sensor Open Circuit or Short Circuit	40-177
FAILURE CODE [879EMC] Ventilation Damper Malfunction	40-179
FAILURE CODE [879FMC] Air Mix Damper Malfunction	40-180
FAILURE CODE [879GKX] Refrigerant Pressure Input Signal Out of Range	40-181
FAILURE CODE [989L00] Engine Controller Lock Caution 1	40-183
FAILURE CODE [989M00] Engine Controller Lock Caution 2	40-184
FAILURE CODE [989N00] Engine Controller Lock Caution 3	40-185
FAILURE CODE [A1U0N3] HC Desorb Request 1	40-186
FAILURE CODE [A1U0N4] HC Desorb Request 2	40-188
FAILURE CODE [A900FR] Abrupt Engine Stop by Auto Idling Stop 3	40-190
FAILURE CODE [A900N6] Abrupt Engine Stop by Auto Idling Stop 1	40-191
FAILURE CODE [A900NY] Abrupt Engine Stop by Auto Idling Stop 2	40-192
FAILURE CODE [AA10NX] Air Cleaner Clogging	40-193
FAILURE CODE [AB00KE] Charge Voltage Low	40-195
FAILURE CODE [AQ10N3] Manual Stationary Regeneration Request (KDOC Face Plugging)	40-198
FAILURE CODE [AS00N3] Manual Stationary Regeneration Request (SCR)	40-200
FAILURE CODE [AS00R2] Warning 2 (SCR Device Abnormality)	40-202
FAILURE CODE [AS00R3] Inducement 1 (SCR Device Abnormality)	40-203
FAILURE CODE [AS00R4] Inducement 2 (SCR Device Abnormality)	40-204
FAILURE CODE [AS00R5] Inducement 3 (SCR Device Abnormality)	40-205
FAILURE CODE [AS00R6] Temporary Recovery of Inducement	40-206
FAILURE CODE [AS00ZK] DEF Level Low Error 5	40-207
FAILURE CODE [AS10KM] DEF Injector Overheat Warning	40-208
FAILURE CODE [AS10NR] DEF Injector High Temperature Warning	40-209
FAILURE CODE [AS10NT] DEF Injector Overheat Caution	40-210
FAILURE CODE [B@BAZG] Engine Oil Pressure Low	40-211
FAILURE CODE [B@BAZK] Eng Oil Level Low	40-212
FAILURE CODE [B@BCNS] Eng Water Overheat	40-214
FAILURE CODE [B@BCZK] Eng Water Level Low	40-215

FAILURE CODE [B@HANS] Hyd Oil Overheat.....	40-217
FAILURE CODE [CA115] Engine NE and Backup Speed Sensor Error.....	40-218
FAILURE CODE [CA122] Charge Air Pressure Sensor High Error.....	40-219
FAILURE CODE [CA123] Charge Air Pressure Sensor Low Error.....	40-221
FAILURE CODE [CA131] Throttle Sensor High Error.....	40-223
FAILURE CODE [CA132] Throttle Sensor Low Error.....	40-225
FAILURE CODE [CA144] Coolant Temperature Sensor High Error.....	40-227
FAILURE CODE [CA145] Coolant Temperature Sensor Low Error.....	40-229
FAILURE CODE [CA153] Charge Air Temperature Sensor High Error.....	40-231
FAILURE CODE [CA154] Charge Air Temperature Sensor Low Error.....	40-234
FAILURE CODE [CA187] Sensor 2 Supply Voltage Low Error.....	40-236
FAILURE CODE [CA221] Ambient Pressure Sensor High Error.....	40-238
FAILURE CODE [CA222] Ambient Pressure Sensor Low Error.....	40-240
FAILURE CODE [CA227] Sensor 2 Supply Voltage High Error.....	40-242
FAILURE CODE [CA234] Engine Overspeed.....	40-243
FAILURE CODE [CA238] NE Speed Sensor Supply Voltage Error.....	40-244
FAILURE CODE [CA239] NE Speed Sensor Supply Voltage High Error.....	40-246
FAILURE CODE [CA249] Ambient Air Temp Sensor High Error.....	40-248
FAILURE CODE [CA256] Ambient Air Temp Sensor Low Error.....	40-250
FAILURE CODE [CA271] IMV or PCV 1 Short Circuit Error.....	40-252
FAILURE CODE [CA272] IMV or PCV 1 Open Circuit Error.....	40-254
FAILURE CODE [CA322] Injector #1 (L#1) Open Circuit Error or Short Circuit Error.....	40-256
FAILURE CODE [CA323] Injector #5 (L#5) Open Circuit Error or Short Circuit Error.....	40-258
FAILURE CODE [CA324] Injector #3 (L#3) Open Circuit Error or Short Circuit Error.....	40-260
FAILURE CODE [CA325] Injector #6 (L#6) Open Circuit Error or Short Circuit Error.....	40-262
FAILURE CODE [CA331] Injector #2 (L#2) Open Circuit Error or Short Circuit Error.....	40-264
FAILURE CODE [CA332] Injector #4 (L#4) Open Circuit Error or Short Circuit Error.....	40-266
FAILURE CODE [CA343] Engine Controller Internal Failure.....	40-268
FAILURE CODE [CA351] Injectors Drive Circuit Error.....	40-269
FAILURE CODE [CA352] Sensor 1 Supply Voltage Low Error.....	40-270
FAILURE CODE [CA356] MAF Sensor High Error.....	40-273
FAILURE CODE [CA357] MAF Sensor Low Error.....	40-275
FAILURE CODE [CA386] Sensor 1 Supply Voltage High Error.....	40-277
FAILURE CODE [CA428] Water in Fuel Sensor High Error.....	40-278
FAILURE CODE [CA429] Water in Fuel Sensor Low Error.....	40-280
FAILURE CODE [CA435] Engine Oil Pressure SW Error.....	40-282
FAILURE CODE [CA441] Battery Voltage Low Error.....	40-284
FAILURE CODE [CA442] Battery Voltage High Error.....	40-286
FAILURE CODE [CA449] Common Rail Pressure High Error 2.....	40-287
FAILURE CODE [CA451] Common Rail Pressure Sensor High Error.....	40-288
FAILURE CODE [CA452] Common Rail Pressure Sensor Low Error.....	40-290
FAILURE CODE [CA488] Charge Air Temperature High Torque Derate.....	40-292
FAILURE CODE [CA515] Common Rail Pressure Sensor Supply Voltage High Error.....	40-293
FAILURE CODE [CA516] Common Rail Pressure Sensor Supply Voltage Low Error.....	40-295
FAILURE CODE [CA553] Common Rail Pressure High Error 1.....	40-297
FAILURE CODE [CA555] Crankcase Pressure High Error 1.....	40-298
FAILURE CODE [CA556] Crankcase Pressure High Error 2.....	40-299
FAILURE CODE [CA559] Common Rail Pressure Low Error 1.....	40-300
FAILURE CODE [CA595] Turbocharger Speed High Error 2.....	40-303
FAILURE CODE [CA687] Turbocharger Speed Low Error.....	40-304
FAILURE CODE [CA689] Engine NE Speed Sensor Error.....	40-306
FAILURE CODE [CA691] Intake Air Temperature Sensor High Error.....	40-309
FAILURE CODE [CA692] Intake Air Temperature Sensor Low Error.....	40-311
FAILURE CODE [CA697] Engine Controller Internal Temperature Sensor High Error.....	40-313
FAILURE CODE [CA698] Engine Controller Internal Temperature Sensor Low Error.....	40-314
FAILURE CODE [CA731] Engine Backup Speed Sensor Phase Error.....	40-315
FAILURE CODE [CA778] Engine Backup Speed Sensor Error.....	40-317
FAILURE CODE [CA1117] Engine Controller Partial Data Lost Error.....	40-322

FAILURE CODE [CA1664] KDOC Abnormality	40-323
FAILURE CODE [CA1669] DEF Level Sensor Voltage High Error.....	40-325
FAILURE CODE [CA1673] DEF Level Low Error 3	40-326
FAILURE CODE [CA1677] DEF Temperature Sensor Low Error	40-327
FAILURE CODE [CA1678] DEF Temperature Sensor High Error	40-328
FAILURE CODE [CA1682] DEF Pump Priming Error	40-329
FAILURE CODE [CA1683] DEF Tank Heating Valve Voltage High Error	40-331
FAILURE CODE [CA1684] DEF Tank Heating Valve Voltage Low Error.....	40-333
FAILURE CODE [CA1686] DEF Quality Sensor Voltage High Error	40-335
FAILURE CODE [CA1691] Defective Regeneration	40-336
FAILURE CODE [CA1694] SCR Outlet NOx Sensor In Range Error.....	40-339
FAILURE CODE [CA1695] Sensor 5 Supply Voltage High Error	40-342
FAILURE CODE [CA1696] Sensor 5 Supply Voltage Low Error	40-343
FAILURE CODE [CA1712] DEF Tank Thawing Error	40-345
FAILURE CODE [CA1713] DEF Tank Heater Valve Open Stuck Error	40-348
FAILURE CODE [CA1714] DEF Quality Sensor Out of Calibration Error.....	40-350
FAILURE CODE [CA1715] DEF Quality Sensor Internal Circuit Error	40-351
FAILURE CODE [CA1776] Sensor Supply Relay Voltage High Error	40-352
FAILURE CODE [CA1777] Sensor Supply Relay Voltage Low Error	40-355
FAILURE CODE [CA1843] Crankcase Pressure Sensor High Error.....	40-358
FAILURE CODE [CA1844] Crankcase Pressure Sensor Low Error.....	40-360
FAILURE CODE [CA1879] KDPF Differential Pressure Sensor High Error	40-363
FAILURE CODE [CA1881] KDPF Differential Pressure Sensor Low Error	40-365
FAILURE CODE [CA1883] KDPF Differential Pressure Sensor In Range Error	40-367
FAILURE CODE [CA1885] Turbo Outlet NOx Sensor Circuit Error	40-370
FAILURE CODE [CA1887] SCR Outlet NOx Sensor Circuit Error	40-372
FAILURE CODE [CA1921] KDPF Soot Accumulation High Error 1	40-374
FAILURE CODE [CA1922] KDPF Soot Accumulation High Error 2	40-377
FAILURE CODE [CA1942] Crankcase Pressure Sensor In Range Error.....	40-382
FAILURE CODE [CA1993] KDPF Differential Pressure Low Error	40-383
FAILURE CODE [CA2185] Throttle Sensor Supply Voltage High Error	40-386
FAILURE CODE [CA2186] Throttle Sensor Supply Voltage Low Error	40-387
FAILURE CODE [CA2249] Common Rail Pressure Low Error 2	40-389
FAILURE CODE [CA2271] EGR Valve Position Sensor High Error	40-390
FAILURE CODE [CA2272] EGR Valve Position Sensor Low Error.....	40-393
FAILURE CODE [CA2288] Turbocharger Speed High Error 1.....	40-396
FAILURE CODE [CA2311] IMV Solenoid Error.....	40-397
FAILURE CODE [CA2349] EGR Valve Solenoid Open Circuit Error.....	40-398
FAILURE CODE [CA2353] EGR Valve Solenoid Short Circuit Error.....	40-401
FAILURE CODE [CA2357] EGR Valve Servo Error.....	40-403
FAILURE CODE [CA2381] KVGT Position Sensor High Error.....	40-404
FAILURE CODE [CA2382] KVGT Position Sensor Low Error	40-407
FAILURE CODE [CA2383] KVGT Solenoid Open Circuit Error	40-410
FAILURE CODE [CA2386] KVGT Solenoid Short Circuit Error	40-413
FAILURE CODE [CA2387] KVGT Servo Error	40-415
FAILURE CODE [CA2555] Intake Air Heater Relay Open Circuit Error	40-416
FAILURE CODE [CA2556] Intake Air Heater Relay Short Circuit Error	40-419
FAILURE CODE [CA2637] KDOC Face Plugging	40-421
FAILURE CODE [CA2639] Manual Stationary Regeneration Request	40-423
FAILURE CODE [CA2771] SCR Outlet NOx Sensor Datalink Timeout Error.....	40-426
FAILURE CODE [CA2777] Manual Stationary Regeneration Request but KDPF Regeneration Disable ..	40-432
FAILURE CODE [CA2976] DEF Pump Temperature Sensor Signal Error	40-435
FAILURE CODE [CA3133] KDPF Outlet Pressure Sensor High Error.....	40-437
FAILURE CODE [CA3134] KDPF Outlet Pressure Sensor Low Error.....	40-440
FAILURE CODE [CA3135] KDPF Outlet Pressure Sensor In Range Error.....	40-442
FAILURE CODE [CA3142] SCR Temperature Sensor High Error.....	40-445
FAILURE CODE [CA3143] SCR Temperature Sensor Low Error	40-446

FAILURE CODE [CA3144]	SCR Temperature Sensor In Range Error	40-447
FAILURE CODE [CA3146]	SCR Outlet Temperature Sensor High Error	40-449
FAILURE CODE [CA3147]	SCR Outlet Temperature Sensor Low Error	40-450
FAILURE CODE [CA3148]	SCR Outlet Temperature Sensor In Range Error	40-451
FAILURE CODE [CA3151]	SCR Catalyst Efficiency Low Error 2.....	40-453
FAILURE CODE [CA3165]	SCR Outlet Temperature High Error	40-458
FAILURE CODE [CA3229]	SCR Temperature High Error.....	40-460
FAILURE CODE [CA3231]	SCR Temperature High Error - Non Regeneration	40-462
FAILURE CODE [CA3232]	Turbo Outlet NOx Sensor Datalink Timeout Error	40-464
FAILURE CODE [CA3235]	SCR Outlet Temperature High Error - Non Regeneration.....	40-468
FAILURE CODE [CA3239]	DEF Line Heater 2 Voltage High Error	40-470
FAILURE CODE [CA3241]	DEF Line Heater 2 Voltage Low Error	40-473
FAILURE CODE [CA3242]	DEF Tank Heating Error.....	40-476
FAILURE CODE [CA3251]	KDOC Inlet Temperature High Error	40-479
FAILURE CODE [CA3253]	KDOC Temperature Error - Non Regeneration	40-481
FAILURE CODE [CA3254]	KDOC Outlet Temperature High Error 1.....	40-484
FAILURE CODE [CA3255]	KDPF Temperature Error - Non Regeneration	40-487
FAILURE CODE [CA3256]	KDPF Outlet Temperature High Error 1	40-490
FAILURE CODE [CA3311]	KDOC Outlet Temperature High Error 2	40-492
FAILURE CODE [CA3312]	KDPF Outlet Temperature High Error 2	40-494
FAILURE CODE [CA3313]	KDOC Inlet Temperature Sensor Low Error	40-497
FAILURE CODE [CA3314]	KDOC Inlet Temperature Sensor High Error	40-499
FAILURE CODE [CA3315]	KDOC Inlet Temperature Sensor In Range Error	40-500
FAILURE CODE [CA3316]	KDOC Outlet Temperature Sensor Low Error	40-502
FAILURE CODE [CA3317]	KDOC Outlet Temperature Sensor High Error	40-504
FAILURE CODE [CA3318]	KDOC Outlet Temperature Sensor In Range Error	40-505
FAILURE CODE [CA3319]	KDPF Outlet Temperature Sensor High Error	40-507
FAILURE CODE [CA3321]	KDPF Outlet Temperature Sensor Low Error	40-508
FAILURE CODE [CA3322]	KDPF Outlet Temperature Sensor In Range Error	40-510
FAILURE CODE [CA3419]	MAF Sensor Supply Voltage High Error.....	40-512
FAILURE CODE [CA3421]	MAF Sensor Supply Voltage Low Error.....	40-514
FAILURE CODE [CA3497]	DEF Level Low Error 1	40-516
FAILURE CODE [CA3498]	DEF Level Low Error 2	40-517
FAILURE CODE [CA3543]	DEF Quality Error (SCR Catalyst Efficiency Low)	40-518
FAILURE CODE [CA3545]	SCR Outlet NOx Sensor Unstable Error	40-524
FAILURE CODE [CA3547]	DEF Level Low Error 4	40-526
FAILURE CODE [CA3558]	DEF Pump Voltage High Error.....	40-527
FAILURE CODE [CA3559]	DEF Pump Voltage Low Error.....	40-529
FAILURE CODE [CA3562]	DEF LineHeater Relay 1 Voltage High Error.....	40-531
FAILURE CODE [CA3563]	DEF LineHeater Relay 1 Voltage Low Error.....	40-533
FAILURE CODE [CA3567]	DEF Injector Open Circuit Error or Short Circuit Error.....	40-536
FAILURE CODE [CA3568]	DEF Injector Malfunction	40-539
FAILURE CODE [CA3571]	DEF Pump Pressure Sensor High Error	40-543
FAILURE CODE [CA3572]	DEF Pump Pressure Sensor Low Error	40-545
FAILURE CODE [CA3574]	DEF Pump Pressure Too Low Error.....	40-547
FAILURE CODE [CA3575]	DEF Pump Pressure Too High Error.....	40-549
FAILURE CODE [CA3577]	DEF FCV Voltage High Error	40-550
FAILURE CODE [CA3578]	DEF FCV Voltage Low Error.....	40-552
FAILURE CODE [CA3582]	SCR Catalyst Efficiency Low Error 1.....	40-554
FAILURE CODE [CA3583]	SCR Outlet NOx Sensor Heater Warming up Error.....	40-559
FAILURE CODE [CA3596]	DEF Pump Pressure Unstable Error	40-561
FAILURE CODE [CA3649]	Turbo Outlet NOx Sensor Heater Warming up Error	40-563
FAILURE CODE [CA3681]	SCR Outlet NOx Sensor Power Voltage Error	40-565
FAILURE CODE [CA3682]	Turbo Outlet NOx Sensor Power Voltage Error.....	40-570
FAILURE CODE [CA3713]	DEF Line Heater 1 Voltage High Error	40-576
FAILURE CODE [CA3717]	SCR Outlet NOx Sensor Voltage Mismatch Error	40-579
FAILURE CODE [CA3718]	Turbo Outlet NOx Sensor Voltage Mismatch Error.....	40-580
FAILURE CODE [CA3725]	Turbo Outlet NOx Sensor Unstable Error.....	40-581

FAILURE CODE [CA3741] Rail Press Valve Trip Error.....	40-584
FAILURE CODE [CA3748] Turbo Outlet NOx Sensor Stuck In Range Error	40-585
FAILURE CODE [CA3751] SCR Catalyst Degradation Error.....	40-587
FAILURE CODE [CA3755] DEF Dosing Performance Degradation Error.....	40-589
FAILURE CODE [CA3866] DEF Low Concentration Error 2.....	40-591
FAILURE CODE [CA3867] DEF Low Concentration Error 1.....	40-594
FAILURE CODE [CA3868] DEF Tank Sensor Datalink Timeout Error	40-597
FAILURE CODE [CA3899] SCR NH3 Sensor Circuit Error.....	40-601
FAILURE CODE [CA3911] SCR NH3 Sensor Datalink Timeout Error	40-603
FAILURE CODE [CA3912] SCR NH3 Sensor Heater Warming up Error	40-607
FAILURE CODE [CA3932] SCR NH3 Sensor Heater Voltage High Error	40-609
FAILURE CODE [CA3933] SCR NH3 Sensor Heater Voltage Low Error.....	40-611
FAILURE CODE [CA3934] SCR NH3 Sensor Power Interrupt Error	40-613
FAILURE CODE [CA3935] SCR NH3 Sensor Trim Resistance Error	40-616
FAILURE CODE [CA3936] SCR NH3 Sensor Internal Circuit Error.....	40-618
FAILURE CODE [CA4151] KDOC and KDPF Temperature Sensor Datalink Timeout Error	40-620
FAILURE CODE [CA4152] SCR Temperature Sensor Datalink Timeout Error	40-624
FAILURE CODE [CA4155] DEF Pump Heater Relay Voltage High Error	40-628
FAILURE CODE [CA4156] DEF Pump Heater Relay Voltage Low Error	40-630
FAILURE CODE [CA4157] DEF FCV Malfunction.....	40-633
FAILURE CODE [CA4158] KDOC and KDPF Temperature Sensor Internal Circuit Error	40-635
FAILURE CODE [CA4159] SCR Temperature Sensor Internal Circuit Error	40-636
FAILURE CODE [CA4161] KDOC and KDPF Temperature Sensor ECU Voltage High Error	40-637
FAILURE CODE [CA4162] KDOC and KDPF Temperature Sensor ECU Voltage Low Error	40-640
FAILURE CODE [CA4163] KDOC and KDPF Temperature Sensor ECU Over Temperature Error.....	40-643
FAILURE CODE [CA4164] SCR Temperature Sensor ECU Voltage High Error	40-645
FAILURE CODE [CA4165] SCR Temperature Sensor ECU Voltage Low Error	40-647
FAILURE CODE [CA4166] SCR Temperature Sensor ECU High Temperature Error	40-649
FAILURE CODE [CA4168] DEF Pump Heater ON Stuck Error	40-651
FAILURE CODE [CA4169] DEF Pump Heater OFF Stuck Error	40-654
FAILURE CODE [CA4171] DEF Pump Thawing Error.....	40-656
FAILURE CODE [CA4249] DEF Pump Temperature Sensor 1 In Range Error.....	40-659
FAILURE CODE [CA4251] DEF Pump Temperature Sensor 2 In Range Error.....	40-661
FAILURE CODE [CA4259] KDOC and KDPF Temperature Sensor Power Interrupt Error.....	40-663
FAILURE CODE [CA4261] SCR Temperature Sensor Power Interrupt Error.....	40-666
FAILURE CODE [CA4277] DEF Quality Sensor Liquid Distinction Impossible Error	40-669
FAILURE CODE [CA4281] SCR NH3 Sensor Stuck Response Error.....	40-672
FAILURE CODE [CA4459] DEF LineHeater Relay 2 Voltage High Error.....	40-675
FAILURE CODE [CA4461] DEF LineHeater Relay 2 Voltage Low Error.....	40-677
FAILURE CODE [CA4658] DEF Flow Low Error	40-680
FAILURE CODE [CA4731] DEF Temperature Sensor Transmission Data Error.....	40-683
FAILURE CODE [CA4732] DEF Level Sensor Transmission Data Error	40-684
FAILURE CODE [CA4739] DEF Level Sensor Internal Circuit Error.....	40-685
FAILURE CODE [CA4768] Fuel in DEF Tank Error	40-686
FAILURE CODE [CA4769] DEF Level Measurement Impossible	40-688
FAILURE CODE [CA4842] DEF High Concentration Error.....	40-691
FAILURE CODE [CA4952] System Operating Lamp Short Circuit (Engine Controller).....	40-694
FAILURE CODE [CA5115] DEF Line Heater 1 Voltage Low Error	40-696
FAILURE CODE [CA5179] Engine Room Temperature Sensor High Error.....	40-699
FAILURE CODE [CA5181] Engine Room Temperature Sensor Low Error	40-701
FAILURE CODE [CA5383] Ash Accumulation High Error.....	40-703
FAILURE CODE [D110KB] Battery Relay Output Short Circuit.....	40-705
FAILURE CODE [D19JKZ] Personal Code Relay Open Circuit or Short Circuit.....	40-707
FAILURE CODE [D811MC] KOMTRAX Malfunction.....	40-710
FAILURE CODE [D862KA] GPS Antenna Open Circuit	40-711
FAILURE CODE [D8ALKA] System Operating Lamp Open Circuit (KOMTRAX).....	40-712
FAILURE CODE [D8ALKB] System Operating Lamp Short Circuit (KOMTRAX).....	40-714
FAILURE CODE [D8AQKR] CAN 2 Defective Communication (KOMTRAX).....	40-716

FAILURE CODE [DA20MC] Pump Controller Malfunction	40-718
FAILURE CODE [DA22KK] Pump Controller Solenoid Power Voltage Low Error	40-719
FAILURE CODE [DA25KP] 5V Sensor 1 Power Voltage Low Error	40-722
FAILURE CODE [DA29KQ] Model Selection Signal Mismatch (Pump Controller)	40-725
FAILURE CODE [DA2LKA] System Operating Lamp Open Circuit (Pump Controller)	40-727
FAILURE CODE [DA2LKB] System Operating Lamp Short Circuit (Pump Controller)	40-729
FAILURE CODE [DA2QKR] Controller Area Network 2 Defective Communication (Pump Controller)	40-731
FAILURE CODE [DA2RKR] Controller Area Network 1 Defective Communication (Pump Controller)	40-734
FAILURE CODE [DAF0MB] Monitor ROM Abnormality	40-735
FAILURE CODE [DAF0MC] Monitor Malfunction	40-736
FAILURE CODE [DAF8KB] Camera Power Supply Short Circuit	40-737
FAILURE CODE [DAF9KQ] Model Selection Signal Mismatch (Monitor)	40-739
FAILURE CODE [DAFGMC] GPS Module Malfunction	40-740
FAILURE CODE [DAFLKA] System Operating Lamp Open Circuit (Monitor)	40-741
FAILURE CODE [DAFLKB] System Operating Lamp Short Circuit (Monitor)	40-743
FAILURE CODE [DAFQKR] CAN 2 Defective Communication (Monitor)	40-745
FAILURE CODE [DAZ9KQ] Model Selection Signal Mismatch (A/C)	40-746
FAILURE CODE [DAZQKR] CAN 2 Defective Communication (A/C ECU)	40-747
FAILURE CODE [DB2QKR] CAN 2 Defective Communication (Engine Controller)	40-752
FAILURE CODE [DB2RKR] CAN 1 Defective Communication (Engine Controller)	40-757
FAILURE CODE [DDNRKA] W/E Lever Lock SW Open Circuit	40-762
FAILURE CODE [DDNRKY] W/E Lever Lock SW Short Circuit	40-764
FAILURE CODE [DDNS00] Lock Lever Auto Lock Release SW On	40-766
FAILURE CODE [DGH2KA] Hydraulic Oil Temperature Sensor Open Circuit	40-768
FAILURE CODE [DGH2KB] Hydraulic Oil Temperature Sensor Ground Fault	40-770
FAILURE CODE [DHA4KA] Air Cleaner Clog Sensor Open Circuit	40-772
FAILURE CODE [DHAAMA] KDPF Differential Pressure Sensor Frozen	40-774
FAILURE CODE [DHACMA] KDPF Outlet Pressure Sensor Frozen	40-776
FAILURE CODE [DHPAMA] Front Pump Pressure Sensor Defective Function	40-778
FAILURE CODE [DHPBMA] Rear Pump Pressure Sensor Defective Function	40-781
FAILURE CODE [DHS3MA] RB Arm IN / LL Arm OUT PPC Pressure Sensor Defective Function	40-784
FAILURE CODE [DHS4MA] Bucket CURL/Heel OUT PPC Pressure Sensor Defective Function	40-787
FAILURE CODE [DHS8MA] Boom RAISE PPC Pressure Sensor Defective Function	40-790
FAILURE CODE [DHS9MA] Boom LOWER PPC Pressure Sensor Defective Function	40-793
FAILURE CODE [DHSAMA] Swing Right PPC Pressure Sensor Defective Function	40-796
FAILURE CODE [DHSBMA] Swing Left PPC Pressure Sensor Defective Function	40-799
FAILURE CODE [DHSCMA] RB Arm OUT / LL Arm IN PPC Pressure Sensor Defective Function	40-802
FAILURE CODE [DHSDMA] Bucket DUMP/Heel IN PPC Pressure Sensor Defective Function	40-805
FAILURE CODE [DHSFMA] Travel Forward Left PPC Pressure Sensor Defective Function	40-808
FAILURE CODE [DHSGMA] Travel Forward Right PPC Pressure Sensor Defective Function	40-811
FAILURE CODE [DHSJMA] Travel Reverse Left PPC Pressure Sensor Defective Function	40-814
FAILURE CODE [DHSJMA] Travel Reverse Right PPC Pressure Sensor Defective Function	40-817
FAILURE CODE [DKR0MA] Front Pump Swash Plate Sensor Defective Function	40-820
FAILURE CODE [DKR1MA] Rear Pump Swash Plate Sensor Defective Function	40-823
FAILURE CODE [DKULKKA] PPC Lock Relay Open Circuit	40-826
FAILURE CODE [DKULKKB] PPC Lock Relay Short Circuit	40-828
FAILURE CODE [DKULKY] PPC Lock Relay Hot Short Circuit	40-830
FAILURE CODE [DR21KX] Camera 2 Picture Reverse Drive Input Out of Range	40-832
FAILURE CODE [DR31KX] Camera 3 Picture Reverse Drive Input Out of Range	40-834
FAILURE CODE [DV20KB] Travel Alarm Short Circuit	40-836
FAILURE CODE [DW43KA] Travel Speed Solenoid Open Circuit	40-838
FAILURE CODE [DW43KB] Travel Speed Solenoid Short Circuit	40-840
FAILURE CODE [DW43KY] Travel Speed Solenoid Hot Short Circuit	40-842
FAILURE CODE [DW45KA] Swing Parking Brake Solenoid Open Circuit	40-844
FAILURE CODE [DW45KB] Swing Parking Brake Solenoid Short Circuit	40-847

FAILURE CODE [DW45KY] Swing Parking Brake Solenoid Hot Short Circuit	40-850
FAILURE CODE [DW4CKY] PPC Lock Solenoid Hot Short Circuit	40-852
FAILURE CODE [DW91KA] Travel Junction Solenoid Open Circuit	40-854
FAILURE CODE [DW91KB] Travel Junction Solenoid Short Circuit	40-856
FAILURE CODE [DW91KY] Travel Junction Solenoid Hot Short Circuit	40-858
FAILURE CODE [DWA2KA] Attachment Single or 2-Way Change Solenoid Open Circuit.....	40-860
FAILURE CODE [DWA2KB] Attachment Single or 2-Way Change Solenoid Short Circuit.....	40-862
FAILURE CODE [DWA2KY] Attachment Single or 2-Way Change Solenoid Hot Short Circuit	40-864
FAILURE CODE [DWK0KA] 2-Stage Relief Solenoid Open Circuit	40-866
FAILURE CODE [DWK0KB] 2-Stage Relief Solenoid Open Circuit	40-868
FAILURE CODE [DWK0KY] 2-Stage Relief Solenoid Hot Short Circuit.....	40-870
FAILURE CODE [DWK2KA] Variable Back Pressure Solenoid Open Circuit	40-872
FAILURE CODE [DWK2KB] Variable Back Pressure Solenoid Short Circuit	40-874
FAILURE CODE [DWK2KY] Variable Back Pressure Solenoid Hot Short Circuit.....	40-876
FAILURE CODE [DWK8KA] Swing Pressure Cutoff Solenoid Open Circuit	40-878
FAILURE CODE [DWK8KB] Swing Pressure Cutoff Solenoid Short Circuit.....	40-880
FAILURE CODE [DWK8KY] Swing Pressure Cutoff Solenoid Hot Short Circuit	40-882
FAILURE CODE [DXA8KA] Front Pump PC-EPC Solenoid Open Circuit.....	40-884
FAILURE CODE [DXA8KB] Front Pump PC-EPC Solenoid Short Circuit	40-886
FAILURE CODE [DXA9KA] Rear Pump PC-EPC Solenoid Open Circuit	40-888
FAILURE CODE [DXA9KB] Rear Pump PC-EPC Solenoid Short Circuit.....	40-890
FAILURE CODE [DXE0KA] LS-EPC Solenoid Open Circuit.....	40-892
FAILURE CODE [DXE0KB] LS-EPC Solenoid Short Circuit.....	40-893
FAILURE CODE [DXE4KA] Attachment Flow Regulating EPC Solenoid Open Circuit	40-895
FAILURE CODE [DXE4KB] Attachment Flow Regulating EPC Solenoid Short Circuit	40-897
FAILURE CODE [DXE4KY] Attachment Flow EPC Hot Short Circuit	40-899
FAILURE CODE [DXE5KA] Merge-divider Main Solenoid Open Circuit	40-901
FAILURE CODE [DXE5KB] Merge-divider Main Solenoid Short Circuit	40-903
FAILURE CODE [DXE6KA] Merge-divider LS Solenoid Open Circuit.....	40-905
FAILURE CODE [DXE6KB] Merge-divider LS Solenoid Short Circuit.....	40-907
FAILURE CODE [DXE7KA] Attachment Flow Regulating EPC 2 Solenoid Open Circuit	40-909
FAILURE CODE [DXE7KB] Attachment Flow Regulating EPC 2 Solenoid Short Circuit	40-911
FAILURE CODE [DXE7KY] Attachment Flow Regulating EPC 2 Hot Short Circuit.....	40-913
FAILURE CODE [DXE8KA] Attachment Flow Regulating EPC 3 Solenoid Open Circuit	40-915
FAILURE CODE [DXE8KB] Attachment Flow Regulating EPC 3 Solenoid Short Circuit	40-917
FAILURE CODE [DXE8KY] Attachment Flow Regulating EPC 3 Hot Short Circuit.....	40-919
FAILURE CODE [DXE9KA] Attachment Flow Regulating EPC 4 Solenoid Open Circuit	40-921
FAILURE CODE [DXE9KB] Attachment Flow Regulating EPC 4 Solenoid Short Circuit	40-923
FAILURE CODE [DXE9KY] Attachment Flow Regulating EPC 4 Hot Short Circuit.....	40-925
FAILURE CODE [DXEAKA] Attachment Flow Regulating EPC 5 Solenoid Open Circuit.....	40-927
FAILURE CODE [DXEAKB] Attachment Flow Regulating EPC 5 Solenoid Short Circuit	40-929
FAILURE CODE [DXEAKY] Attachment Flow Regulating EPC 5 Hot Short Circuit	40-931
FAILURE CODE [DY20KA] Wiper Motor Open Circuit	40-933
FAILURE CODE [DY20MA] Wiper Motor Defective Function	40-935
FAILURE CODE [DY2CKB] Washer Motor Short Circuit	40-937
FAILURE CODE [DY2DKB] Wiper Motor (Normal Rotation) Short Circuit	40-940
FAILURE CODE [DY2EKB] Wiper Motor (Reverse Rotation) Short Circuit.....	40-942
FAILURE CODE [DFB1KZ] Service Lever Potentio 1 Abnormality	40-944
FAILURE CODE [DFB2KZ] Service Lever Potentio 2 Abnormality	40-946
FAILURE CODE [DFB5KZ] Service Lever Sub Potentio 1 Abnormality	40-948
FAILURE CODE [DFB6KZ] Service Lever Sub Potentio 2 Abnormality	40-950
FAILURE CODE [DFB3L8] Service Lever 1 Potentio Error.....	40-952
FAILURE CODE [DFB4L8] Service Lever 2 Potentio Error.....	40-953
TROUBLESHOOTING OF ELECTRICAL SYSTEM (E-MODE)	40-955
E-1 ENGINE DOES NOT START (ENGINE DOES NOT CRANK)	40-955
E-2 MANUAL PREHEATING SYSTEM DOES NOT WORK.....	40-961
E-3 AUTOMATIC PREHEATING SYSTEM DOES NOT WORK	40-964
E-4 WHILE PREHEATING IS WORKING, PREHEATING MONITOR DOES NOT LIGHT UP	40-966

E-5 WHEN STARTING SWITCH IS TURNED TO ON POSITION, MACHINE MONITOR DISPLAYS NOTHING.....	40-968
E-6 WHILE STARTING SWITCH IS TURNED TO ON POSITION (WITH ENGINE STOPPED), ENGINE OIL LEVEL MONITOR LIGHTS UP IN YELLOW	40-971
E-7 WHILE STARTING SWITCH IS TURNED TO ON POSITION (WITH ENGINE STOPPED), RADIATOR COOLANT LEVEL MONITOR LIGHTS UP IN YELLOW	40-972
E-8 ENGINE COOLANT TEMPERATURE MONITOR LIGHTS UP IN WHITE WHILE ENGINE IS RUNNING	40-973
E-9 HYDRAULIC OIL TEMPERATURE MONITOR LIGHTS UP IN WHITE WHILE ENGINE IS RUNNING	40-974
E-10 AIR CLEANER CLOGGING MONITOR LIGHTS UP IN YELLOW WHILE ENGINE IS RUNNING	40-975
E-11 CHARGE LEVEL MONITOR LIGHTS UP IN RED WHILE ENGINE IS RUNNING	40-976
E-12 FUEL LEVEL MONITOR LIGHTS UP IN RED WHILE ENGINE IS RUNNING	40-977
E-13 WATER SEPARATOR MONITOR LIGHTS UP IN RED WHILE ENGINE IS RUNNING	40-978
E-14 ENGINE COOLANT TEMPERATURE MONITOR LIGHTS UP IN RED WHILE ENGINE IS RUNNING	40-979
E-15 ENGINE OIL PRESSURE MONITOR LIGHTS UP IN RED WHILE ENGINE IS RUNNING ..	40-980
E-16 HYDRAULIC OIL TEMPERATURE MONITOR LIGHTS UP IN RED WHILE ENGINE IS RUNNING	40-981
E-17 FUEL GAUGE DISPLAY DOES NOT MOVE FROM MINIMUM OR MAXIMUM	40-982
E-18 DISPLAY OF FUEL GAUGE DIFFERS FROM ACTUAL FUEL LEVEL.....	40-984
E-19 ENGINE COOLANT TEMPERATURE GAUGE DISPLAY DOES NOT MOVE FROM MINIMUM OR MAXIMUM.....	40-985
E-20 DISPLAY OF ENGINE COOLANT TEMPERATURE GAUGE DIFFERS FROM ACTUAL COOLANT TEMPERATURE.....	40-986
E-21 HYDRAULIC OIL TEMPERATURE GAUGE DISPLAY DOES NOT MOVE FROM MINIMUM OR MAXIMUM.....	40-987
E-22 DISPLAY OF HYDRAULIC OIL TEMPERATURE GAUGE DIFFERS FROM ACTUAL OIL TEMPERATURE	40-989
E-23 SOME AREAS OF MACHINE MONITOR SCREEN ARE NOT DISPLAYED	40-990
E-24 FUNCTION SWITCH DOES NOT OPERATE	40-991
E-25 AUTOMATIC WARM-UP SYSTEM DOES NOT WORK (IN COLD WEATHER).....	40-992
E-26 WHEN AUTO-DECELERATOR SWITCH IS OPERATED, AUTO-DECELERATOR MONITOR DOES NOT LIGHT UP OR DOES NOT GO OFF	40-993
E-27 AUTO-DECELERATOR IS NOT OPERATED OR CANCELED WITH LEVER	40-994
E-28 WHEN WORKING MODE SWITCH IS OPERATED, WORKING MODE SELECTION SCREEN IS NOT DISPLAYED	40-995
E-29 WHEN WORKING MODE IS CHANGED, SETTING OF ENGINE AND HYDRAULIC PUMP IS NOT CHANGED.....	40-996
E-30 WHEN TRAVEL SPEED SWITCH IS OPERATED, TRAVEL SPEED MONITOR DOES NOT CHANGE.....	40-997
E-31 WHEN TRAVEL SPEED SELECTION IS CHANGED, ACTUAL TRAVEL SPEED DOES NOT CHANGE.....	40-998
E-32 ALARM BUZZER CANNOT BE CANCELED	40-1000
E-33 SERVICE METER IS NOT DISPLAYED, WHILE STARTING SWITCH IS IN OFF POSITION.....	40-1001
E-34 SERVICE MODE CANNOT BE SELECTED	40-1002
E-35 ALL OF WORK EQUIPMENTS, SWING, AND TRAVEL MECHANISM DO NOT MOVE	40-1003
E-36 ALL OF WORK EQUIPMENT, SWING, AND TRAVEL MECHANISM DO NOT LOCK.....	40-1006
E-37 WHEN SWING BRAKE CANCEL SWITCH IS SET TO CANCEL POSITION, MACHINE CANNOT SWING	40-1008
E-38 WHEN SWING BRAKE CANCEL SWITCH IS SET TO NORMAL POSITION, SWING HOLDING BRAKE DOES NOT OPERATE	40-1011
E-39 ONE-TOUCH POWER MAXIMIZING FUNCTION DOES NOT OPERATE PROPERLY, OR INDICATOR NOT DISPLAYED ON MONITOR	40-1013
E-40 ONE-TOUCH POWER MAXIMIZING FUNCTION IS NOT CANCELLED	40-1016
E-41 ALARM DOES NOT SOUND DURING TRAVEL	40-1017

E-42 ALARM DOES NOT STOP SOUNDING WHILE MACHINE IS STOPPED.....	40-1019
E-43 HORN DOES NOT SOUND.....	40-1020
E-44 HORN DOES NOT STOP SOUNDING.....	40-1023
E-45 WHEN WIPER SWITCH IS OPERATED, WIPER MONITOR DOES NOT LIGHT UP OR GO OFF	40-1025
E-46 WHEN WIPER SWITCH IS OPERATED, WINDSHIELD WIPER DOES NOT OPERATE...	40-1026
E-47 WHEN WINDOW WASHER SWITCH IS OPERATED, WINDOW WASHER DOES NOT OPER- ATE	40-1028
E-48 BOOM RAISE INDICATOR IS NOT DISPLAYED PROPERLY WITH MONITORING FUNCTION	40-1029
E-49 BOOM LOWER INDICATOR IS NOT DISPLAYED PROPERLY WITH MONITORING FUNCTION	40-1030
E-50 ARM OUT INDICATOR IS NOT DISPLAYED PROPERLY WITH MONITORING FUNCTION.....	40-1031
E-51 RB Arm IN / LL Arm OUT INDICATOR IS NOT DISPLAYED PROPERLY WITH MONITORING FUNCTION.....	40-1032
E-52 BUCKET DUMP/HEEL IN INDICATOR IS NOT DISPLAYED PROPERLY WITH MONITORING FUNCTION.....	40-1033
E-53 BUCKET CURL/HEEL OUT INDICATOR IS NOT DISPLAYED PROPERLY WITH MONITORING FUNCTION.....	40-1034
E-54 SWING INDICATOR IS NOT DISPLAYED PROPERLY WITH MONITORING FUNCTION.	40-1035
E-55 TRAVEL INDICATOR IS NOT DISPLAYED PROPERLY WITH MONITORING FUNCTION	40-1036
E-56 SERVICE INDICATOR IS NOT DISPLAYED PROPERLY WITH MONITORING FUNCTION	40-1037
E-57 ATTACHMENT HYDRAULIC CIRCUIT CANNOT BE CHANGED.....	40-1039
E-58 KOMTRAX SYSTEM DOES NOT OPERATE NORMALLY	40-1040
TRROUBLESHOOTING FOR HYDRAULIC AND MECHANICAL SYSTEMS (H MODE)	40-1041
INFORMATION MENTIONED IN TROUBLESHOOTING TABLE (H MODE).....	40-1041
SYSTEM CHART OF HYDRAULIC AND MECHANICAL SYSTEMS	40-1042
FAILURE MODE AND CAUSE TABLE	40-1044
H-1 ANY OF WORK EQUIPMENT, SWING AND TRAVEL DOES NOT WORK	40-1053
H-2 ALL OF WORK EQUIPMENTS, SWING AND TRAVEL OPERATION LACK SPEED OR POWER	40-1054
H-3 FINE CONTROL PERFORMANCE OR RESPONSE IS POOR.....	40-1057
H-4 UNUSUAL SOUND IS HEARD FROM AROUND HYDRAULIC PUMP	40-1058
H-5 ENGINE SPEED DROPS LARGELY OR ENGINE STOPS	40-1059
H-6 SPEED OR POWER OF BOOM IS LOW	40-1061
H-7 SPEED OR POWER OF ARM IS LOW	40-1065
H-8 SPEED OR POWER OF BUCKET/HEEL IS LOW.....	40-1070
H-9 WORK EQUIPMENT DOES NOT MOVE IN SINGLE OPERATION	40-1073
H-10 HYDRAULIC DRIFT OF BOOM IS LARGE	40-1074
H-11 HYDRAULIC DRIFT OF ARM IS LARGE	40-1076
H-12 HYDRAULIC DRIFT OF BUCKET/HEEL IS LARGE.....	40-1078
H-13 OTHER WORK EQUIPMENT MOVES WHEN ONE OF WORK EQUIPMENT IS RELIEVED	40-1079
H-14 TIME LAG OF WORK EQUIPMENT IS LARGE	40-1080
H-15 ONE-TOUCH POWER MAXIMIZING FUNCTION DOES NOT WORK.....	40-1081
H-16 ATTACHMENT CIRCUIT CANNOT BE CHANGED.....	40-1082
H-17 OIL FLOW IN ATTACHMENT CIRCUIT CANNOT BE CONTROLLED	40-1083
H-18 IN COMBINED OPERATION OF WORK EQUIPMENT , EQUIPMENT HAVING HEAVIER LOAD MOVES SLOWER.....	40-1084
H-19 TRAVEL SPEED DROPS LARGELY IN COMBINED OPERATION OF SWING AND TRAVE	40-1085
H-20 IN COMBINED OPERATION OF SWING AND BOOM RAISE, BOOM RISING SPEED IS LOW	40-1086
H-21 MACHINE DOES NOT TRAVEL STRAIGHT	40-1087
H-22 MACHINE IS HARD TO STEER OR TRAVEL POWER IS LOW	40-1089
H-23 TRAVEL SPEED IS LOW	40-1092

H-24 ONE OF TRACKS DOES NOT RUN	40-1094
H-25 TRAVEL SPEED DOES NOT CHANGE, OR TRAVEL SPEED IS TOO LOW OR HIGH	40-1095
H-26 UPPER STRUCTURE DOES NOT SWING IN BOTH RIGHT AND LEFT DIRECTIONS....	40-1096
H-27 UPPER STRUCTURE SWING IN ONLY ONE DIRECTION	40-1097
H-28 SWING ACCELERATION OR SWING SPEED OF UPPER STRUCTURE IS LOW IN BOTH RIGHT AND LEFT DIRECTIONS	40-1098
H-29 SWING ACCELERATION OR SWING SPEED IS LOW IN ONLY ONE DIRECTION	40-1099
H-30 OVERRUN OF UPPER STRUCTURE IS LARGE IN BOTH RIGHT AND LEFT DIRECTIONS	40-1100
H-31 UPPER STRUCTURE OVERRUNS EXCESSIVELY WHEN IT STOPS SWING IN ONLY ONE DI- RECTION	40-1101
H-32 SHOCK IS LARGE WHEN UPPER STRUCTURE STOPS SWINGING	40-1102
H-33 LARGE UNUSUAL NOISE IS HEARD WHEN UPPER STRUCTURE STOPS SWINGING	40-1103
H-34 SWING DRIFT ON A SLOPE IS LARGE (WHILE SWING PARKING BRAKE IS APPLIED)	40-1104
H-35 SWING DRIFT ON A SLOPE IS LARGE (WHILE SWING PARKING BRAKE IS RELEASED).....	40-1105
TROUBLESHOOTING OF ENGINE (S-MODE)	40-1106
INFORMATION MENTIONED IN TROUBLESHOOTING TABLE (S MODE).....	40-1106
S-1 ENGINE DOES NOT CRANK WHEN STARTING SWITCH IS TURNED TO START POSITION.....	40-1107
S-2 ENGINE CRANKS BUT NO EXHAUST GAS COMES OUT	40-1108
S-3 FUEL IS BEING INJECTED BUT ENGINE DOES NOT START (MISFIRING: ENGINE CRANKS BUT DOES NOT START)	40-1109
S-4 ENGINE STARTABILITY IS POOR.....	40-1110
S-5 ENGINE DOES NOT PICK UP SMOOTHLY	40-1112
S-6 ENGINE STOPS DURING OPERATION	40-1114
S-7 ENGINE RUNS ROUGH OR IS UNSTABLE	40-1116
S-8 ENGINE LACKS POWER.....	40-1117
S-9 KDPF GETS CLOGGED IN A SHORT TIME.....	40-1119
S-10 ENGINE OIL CONSUMPTION IS EXCESSIVE	40-1121
S-11 OIL BECOMES CONTAMINATED QUICKLY	40-1122
S-12 FUEL CONSUMPTION IS EXCESSIVE	40-1123
S-13 OIL IS IN COOLANT (OR COOLANT SPURTS BACK OR COOLANT LEVEL GOES DOWN)	40-1124
S-14 OIL PRESSURE DROPS	40-1125
S-15 FUEL MIXES INTO ENGINE OIL.....	40-1127
S-16 WATER MIXES INTO ENGINE OIL (MILKY)	40-1128
S-17 COOLANT TEMPERATURE RISES TOO HIGH (OVERHEATING).....	40-1129
S-18 UNUSUAL NOISE IS HEARD.....	40-1130
S-19 VIBRATION IS EXCESSIVE.....	40-1131
S-20 AIR CANNOT BE BLED FROM FUEL CIRCUIT.....	40-1132
S-21 ACTIVE REGENERATION IS EXECUTED FREQUENTLY	40-1133
S-22 ACTIVE REGENERATION TAKES TIME.....	40-1135
S-23 WHITE SMOKE IS EXHAUSTED DURING ACTIVE REGENERATION.....	40-1136
S-24 DEF CONSUMPTION IS EXCESSIVE	40-1137
S-25 THERE IS UNUSUAL SMELL (IRRITATING ODOR)	40-1139
S-26 FOREIGN MATERIALS ENTER DEF (DEF INCREASES).....	40-1140
50 DISASSEMBLY AND ASSEMBLY	50-1
CONTENTS	50-2
ABBREVIATION LIST	50-7
RELATED INFORMATION ON DISASSEMBLY AND ASSEMBLY	50-12
HOW TO READ THIS MANUAL.....	50-12
COATING MATERIALS LIST.....	50-14
SPECIAL TOOLS LIST	50-19
SKETCHES OF SPECIAL TOOLS.....	50-31
ENGINE AND COOLING SYSTEM.....	50-36
REMOVE AND INSTALL SUPPLY PUMP ASSEMBLY	50-36
REMOVE AND INSTALL INJECTOR ASSEMBLY	50-43

REMOVE AND INSTALL CYLINDER HEAD ASSEMBLY	50-56
REMOVE AND INSTALL EGR VALVE ASSEMBLY	50-82
REMOVE AND INSTALL EGR COOLER ASSEMBLY	50-86
REMOVE AND INSTALL STARTER ASSEMBLY	50-94
REMOVE AND INSTALL ALTERNATOR BELT	50-98
REMOVE AND INSTALL RADIATOR ASSEMBLY	50-102
REMOVE AND INSTALL HYDRAULIC OIL COOLER ASSEMBLY	50-106
REMOVE AND INSTALL AFTERCOOLER ASSEMBLY	50-112
REMOVE AND INSTALL ENGINE AND MAIN PUMP ASSEMBLY	50-115
REMOVE AND INSTALL ENGINE FRONT OIL SEAL	50-135
REMOVE AND INSTALL ENGINE REAR OIL SEAL	50-142
REMOVE AND INSTALL FUEL COOLER ASSEMBLY	50-146
REMOVE AND INSTALL ENGINE HOOD ASSEMBLY	50-148
REMOVE AND INSTALL FUEL TANK ASSEMBLY	50-156
REMOVE AND INSTALL DEF TANK ASSEMBLY	50-164
REMOVE AND INSTALL DEF TANK SENSOR FLANGE ASSEMBLY	50-175
REMOVE AND INSTALL DEF TANK SENSOR	50-186
REMOVE AND INSTALL DEF TANK STRAINER	50-188
REMOVE AND INSTALL KDPF ASSEMBLY	50-189
DISASSEMBLE AND ASSEMBLE OF KDPF ASSEMBLY	50-193
REMOVE AND INSTALL SCR ASSEMBLY	50-202
REMOVE AND INSTALL KDPF, SCR ASSEMBLY	50-206
REMOVE AND INSTALL KDPF, SCR ASSEMBLY BRACKET	50-218
REMOVE AND INSTALL KCCV ASSEMBLY	50-233
REMOVE AND INSTALL DEF MIXING TUBE	50-240
REMOVE AND INSTALL DEF INJECTOR	50-250
REMOVE AND INSTALL DEF PUMP	50-254
REMOVE AND INSTALL DEF HOSE	50-259
REMOVE AND INSTALL AIR CLEANER ASSEMBLY	50-272
REMOVE AND INSTALL AIR CONDITIONER COMPRESSOR ASSEMBLY	50-275
REMOVE AND INSTALL AIR CONDITIONER CONDENSER ASSEMBLY	50-280
POWER TRAIN	50-282
REMOVE AND INSTALL TRAVEL MOTOR AND FINAL DRIVE ASSEMBLY	50-282
DISASSEMBLE AND ASSEMBLE FINAL DRIVE ASSEMBLY	50-285
REMOVE AND INSTALL SWING MOTOR AND SWING MACHINERY ASSEMBLY	50-298
DISASSEMBLE AND ASSEMBLE SWING MACHINERY ASSEMBLY	50-301
REMOVE AND INSTALL SWING CIRCLE ASSEMBLY	50-312
UNDERCARRIAGE AND FRAME	50-314
SEPARATION AND CONNECTION OF TRACK ASSEMBLY	50-314
REMOVE AND INSTALL SPROCKET	50-320
REMOVE AND INSTALL IDLER AND IDLER CUSHION ASSEMBLY	50-322
DISASSEMBLE AND ASSEMBLE IDLER ASSEMBLY	50-324
DISASSEMBLE AND ASSEMBLE OF RECOIL SPRING	50-329
DISASSEMBLE AND TRACK ROLLER AND CARRIER ROLLER	50-332
REMOVE AND INSTALL REVOLVING FRAME ASSEMBLY	50-336
REMOVE AND INSTALL COUNTERWEIGHT ASSEMBLY	50-341
HYDRAULIC SYSTEM	50-348
REMOVE AND INSTALL CENTER SWIVEL JOINT ASSEMBLY	50-348
DISASSEMBLE AND ASSEMBLE CENTER SWIVEL JOINT ASSEMBLY	50-353
REMOVE AND INSTALL HYDRAULIC TANK ASSEMBLY	50-356
REMOVE AND INSTALL MAIN PUMP ASSEMBLY	50-361
REMOVE AND INSTALL CONTROL VALVE ASSEMBLY	50-367
DISASSEMBLE AND ASSEMBLE CONTROL VALVE ASSEMBLY	50-380
DISASSEMBLE AND ASSEMBLE WORK EQUIPMENT PPC VALVE ASSEMBLY	50-386
DISASSEMBLE AND ASSEMBLE TRAVEL PPC VALVE ASSEMBLY	50-388
WORK EQUIPMENT	50-391
REMOVE AND INSTALL WORK EQUIPMENT ASSEMBLY	50-391

DISASSEMBLE AND ASSEMBLE WORK EQUIPMENT CYLINDER ASSEMBLY (ROAD BUILDER).....	50-398
DISASSEMBLE AND ASSEMBLE WORK EQUIPMENT CYLINDER ASSEMBLY (LOG LOADER)	50-407
CAB AND ITS ATTACHMENTS	50-416
REMOVE AND INSTALL OPERATOR CAB	50-416
REMOVE AND INSTALL OPERATOR CAB GLASS (FIXED GLASS).....	50-424
REMOVE AND INSTALL FLOOR FRAME ASSEMBLY.....	50-435
REMOVE AND INSTALL 48 INCH RISER	50-441
REMOVE AND INSTALL 7 INCH RISER	50-443
REMOVE AND INSTALL AIR CONDITIONER UNIT ASSEMBLY	50-444
REMOVE AND INSTALL OPERATOR'S SEAT	50-455
REMOVE AND INSTALL SEAT BELT	50-460
REMOVE AND INSTALL FRONT WIPER ASSEMBLY	50-462
ELECTRICAL SYSTEM	50-475
REMOVE AND INSTALL ENGINE CONTROLLER ASSEMBLY	50-475
REMOVE AND INSTALL PUMP CONTROLLER ASSEMBLY	50-478
REMOVE AND INSTALL MACHINE MONITOR ASSEMBLY	50-487
REMOVE AND INSTALL PUMP SWASH PLATE SENSOR.....	50-494
REMOVE AND INSTALL MASS AIR FLOW AND TEMPERATURE SENSOR.....	50-496
REMOVE AND INSTALL KCCV CRANKCASE PRESSURE SENSOR.....	50-498
REMOVE AND INSTALL SCR TEMPERATURE SENSOR.....	50-500
REMOVE AND INSTALL KOMTRAX TERMINAL ASSEMBLY.....	50-504
60 MAINTENANCE STANDARD.....	60-1
CONTENTS	60-2
ABBREVIATION LIST	60-3
ENGINE AND COOLING SYSTEM.....	60-8
MAINTENANCE STANDARD OF ENGINE MOUNT	60-8
MAINTENANCE STANDARD OF COOLING SYSTEM	60-9
POWER TRAIN.....	60-10
MAINTENANCE STANDARD OF SWING CIRCLE	60-10
MAINTENANCE STANDARD OF SWING MACHINERY.....	60-11
MAINTENANCE STANDARD OF FINAL DRIVE	60-13
MAINTENANCE STANDARD OF SPROCKET	60-15
MAINTENANCE STANDARD OF SPROCKET TOOTH PROFILE FULL-SCALE DRAWING.....	60-16
UNDERCARRIAGE AND FRAME.....	60-18
MAINTENANCE STANDARD OF TRACK FRAME AND IDLER CUSHION.....	60-18
MAINTENANCE STANDARD OF IDLER	60-20
MAINTENANCE STANDARD OF TRACK/CARRIER ROLLER.....	60-21
MAINTENANCE STANDARD OF TRACK SHOE.....	60-23
MAINTENANCE STANDARD OF DOUBLE GROUSER SHOE.....	60-26
MAINTENANCE STANDARD OF TRIPLE GROUSER SHOE.....	60-27
HYDRAULIC SYSTEM.....	60-28
MAINTENANCE STANDARD OF HYDRAULIC TANK	60-28
MAINTENANCE STANDARD OF MAIN PUMP.....	60-29
MAINTENANCE STANDARD OF LS-EPC VALVE	60-30
MAINTENANCE STANDARD OF PC-EPC VALVE.....	60-31
MAINTENANCE STANDARD OF SWING MOTOR.....	60-32
MAINTENANCE STANDARD OF TRAVEL MOTOR	60-35
MAINTENANCE STANDARD OF CONTROL VALVE.....	60-38
MAINTENANCE STANDARD OF WORK EQUIPMENT AND SWING PPC VALVE	60-48
MAINTENANCE STANDARD OF TRAVEL PPC VALVE	60-51
MAINTENANCE STANDARD OF 1ST-LINE ATTACHMENT PPC VALVE (WITH EPC VALVE).....	60-54
MAINTENANCE STANDARD OF 2ND-LINE ATTACHMENT PPC VALVE	60-57
MAINTENANCE STANDARD OF SOLENOID VALVE.....	60-59
MAINTENANCE STANDARD OF ATTACHMENT CIRCUIT SELECTOR VALVE (FOR HIGH PRES- SURE).....	60-60

MAINTENANCE STANDARD OF ATTACHMENT CIRCUIT SELECTOR VALVE (FOR LOW PRES- SURE)	60-61
MAINTENANCE STANDARD OF CENTER SWIVEL JOINT	60-62
WORK EQUIPMENT	60-63
MAINTENANCE STANDARD OF WORK EQUIPMENT LINKAGE (ROAD BUILDER)	60-63
MAINTENANCE STANDARD OF WORK EQUIPMENT LINKAGE (LOG LOADER)	60-72
MAINTENANCE STANDARD OF BOOM CYLINDER	60-78
MAINTENANCE STANDARD OF ARM CYLINDER	60-80
MAINTENANCE STANDARD OF BUCKET/HEEL CYLINDER	60-82
80 APPENDIX	80-1
CONTENTS	80-2
ABBREVIATION LIST	80-4
AIR CONDITIONER SYSTEM	80-9
PRECAUTIONS FOR REFRIGERANT	80-9
AIR CONDITIONER COMPONENT	80-10
SPECIFICATIONS OF AIR CONDITIONER	80-12
CONFIGURATION AND FUNCTION OF REFRIGERATION CYCLE	80-13
OUTLINE OF REFRIGERATION CYCLE	80-14
COMPONENT PARTS OF AIR CONDITIONER SYSTEM	80-16
EXPLANATION OF PROCEDURE FOR TESTING AND TROUBLESHOOTING OF AIR CONDITIO- NER	80-30
CIRCUIT DIAGRAM AND ARRANGEMENT OF CONNECTOR PINS FOR AIR CONDITIONER ..	80-32
AIR CONDITIONER SYSTEM DIAGRAM	80-34
INSTALLATION LOCATIONS OF AIR CONDITIONER PARTS AND ARRANGEMENT OF CONNEC- TORS	80-37
TESTING AIR LEAKAGE (DUCT)	80-41
TESTING AIR CONDITIONER USING SELF-DIAGNOSIS FUNCTION	80-43
HOW TO OPEN THE ELECTRICAL SYSTEM ABNORMALITY RECORD SCREEN IN SERVICE MODE OF THE MACHINE MONITOR	80-44
TEST VENT (MODE) CHANGEOVER	80-45
TESTING FRESH/RECIRC AIR CHANGEOVER	80-47
TEST SUNLIGHT SENSOR	80-48
TEST (DUAL) PRESSURE SWITCH FOR REFRIGERANT	80-49
TEST RELAYS	80-50
AIR CONDITIONER TROUBLESHOOTING CHART 1	80-51
AIR CONDITIONER TROUBLESHOOTING CHART 2	80-52
INFORMATION DESCRIBED IN TROUBLESHOOTING TABLE	80-55
FAILURE CODE [879AKA] A/C Recirculation Air Temperature Sensor Open Circuit	80-57
FAILURE CODE [879AKB] A/C Recirculation Air Temperature Sensor Short Circuit	80-58
FAILURE CODE [879BKA] A/C Fresh Air Temperature Sensor Open Circuit	80-59
FAILURE CODE [879BKB] A/C Fresh Air Temperature Sensor Short Circuit	80-61
FAILURE CODE [879CKA] Ventilating Sensor Open Circuit	80-63
FAILURE CODE [879CKB] Ventilating Sensor Short Circuit	80-64
FAILURE CODE [879DKZ] Sunlight Sensor Open Circuit or Short Circuit	80-65
FAILURE CODE [879EMC] Ventilation Damper Malfunction	80-67
FAILURE CODE [879FMC] Air Mix Damper Malfunction	80-68
FAILURE CODE [879GKX] Refrigerant Pressure Input Signal Out of Range	80-69
A-1 TROUBLESHOOTING FOR POWER SUPPLY SYSTEM (AIR CONDITIONER DOES NOT OPER- ATE)	80-71
A-2 TROUBLESHOOTING FOR COMPRESSOR AND REFRIGERANT SYSTEM (AIR IS NOT COOLED)	80-73
A-3 TROUBLESHOOTING FOR BLOWER MOTOR SYSTEM (NO AIR COMES OUT OR AIR FLOW IS ABNORMAL)	80-76
A-4 TROUBLESHOOTING FOR FRESH/RECIRC AIR CHANGEOVER	80-78
TROUBLESHOOTING USING GAUGE PRESSURE	80-80
CONNECTION OF SERVICE TOOL	80-83
PRECAUTIONS FOR DISCONNECTING AND CONNECTING HOSES AND TUBES IN AIR CONDI- TIONER PIPINGS	80-85

HANDLE COMPRESSOR OIL	80-87
METHOD FOR REPLACING DESICCANT	80-89
PROCESSOR HEAD OPTION.....	80-91
STRUCTURE AND FUNCTION	80-91
PRECAUTIONS	80-99
INITIAL SETUP OF MACHINE.....	80-101
VERIFY AND ADJUST.....	80-107
TROUBLESHOOT PROCESSOR.....	80-122
DISASSEMBLY AND ASSEMBLY.....	80-125
CIRCUIT DIAGRAMS	80-134
90 CIRCUIT DIAGRAMS	90-1
CONTENTS	90-2
HYDRAULIC CIRCUIT DIAGRAM	90-3
SYMBOLS IN HYDRAULIC CIRCUIT DIAGRAMS	90-3
HYDRAULIC CIRCUIT DIAGRAM (1/3)	90-8
HYDRAULIC CIRCUIT DIAGRAM (2/3)	90-10
HYDRAULIC CIRCUIT DIAGRAM (3/3)	90-12
ELECTRICAL CIRCUIT DIAGRAM.....	90-13
SYMBOLS IN ELECTRICAL CIRCUIT DIAGRAMS	90-13
ELECTRICAL CIRCUIT DIAGRAM (1/7).....	90-18
ELECTRICAL CIRCUIT DIAGRAM (2/7).....	90-20
ELECTRICAL CIRCUIT DIAGRAM (3/7).....	90-22
ELECTRICAL CIRCUIT DIAGRAM (4/7).....	90-24
ELECTRICAL CIRCUIT DIAGRAM (5/7).....	90-26
ELECTRICAL CIRCUIT DIAGRAM (6/7).....	90-28
ELECTRICAL CIRCUIT DIAGRAM (7/7).....	90-30
ELECTRICAL CIRCUIT DIAGRAM, PROCESSOR/MAXIXPLORER (1/2).....	90-32
ELECTRICAL CIRCUIT DIAGRAM, PROCESSOR/MAXIXPLORER (2/2).....	90-34
INDEX.....	1

ABBREVIATION LIST

- This list of abbreviations includes the abbreviations used in the text of the shop manual for parts, components, and functions whose meaning is not immediately clear. The spelling is given in full with an outline of the meaning.
- Abbreviations that are used in general society may not be included.
- Special abbreviations which appear infrequently are noted in the text.
- This list of abbreviations consists of two parts. The first part is a list of the abbreviations used in the text of the manual, and the second part is a list of the abbreviations used in the circuit diagrams.

List of abbreviations used in the text

Abbreviation	Actual word spelled out	Purpose of use (major applicable machine (*), or component/system)	Explanation
ABS	Anti-skid Brake System	Travel and brake (HD, HM)	When the tires skid (wheels stop rotating), the brakes are released, and when the wheels start to rotate, the brakes are applied again.
AISS	Automatic Idling Setting System	Engine	This function automatically sets the idle speed.
AJSS	Advanced Joystick Steering System	Steering (WA)	A lever is used to perform the steering operations instead of a steering wheel. Moreover, it shifts gear and changes direction (FORWARD or REVERSE).
ARAC	Automatic Retarder Accelerator Control	Travel and brake (HD, HM)	When the accelerator pedal is released while the machine is traveling downhill, this function automatically applies the retarder with a constant braking force.
ARSC	Automatic Retarder Speed Control	Travel and brake (HD, HM)	When the accelerator pedal is released while the machine is traveling downhill, this function automatically applies the retarder to ensure that the machine speed does not accelerate above the speed set by the operator.
ASR	Automatic Spin Regulator	Travel and brake (HD, HM)	When the tires spin on soft ground surfaces, this function automatically uses the optimum braking force to drive both wheels.
ATT	Attachment	Work equipment	A device that can be fixed onto the standard machine in order to enable it to do different jobs.
BCV	Brake cooling oil control valve	Brake (HD)	When the retarder is not being used, this valve bypasses part of the brake cooling oil to reduce the load on the hydraulic pump.
CAN	Controller Area Network	Communication and electronic control	One of communication standards that is used in the network on the machine.
CDR	Crankcase Depression Regulator	Engine	A regulator valve which is installed to KCCV ventilator. It is written as CDR valve and it is not used independently.
CLSS	Closed-center Load Sensing System	Hydraulic system	This system can simultaneously actuate multiple actuators regardless of the load (provides better combined operation than OLSS).
CRI	Common Rail Injection	Engine	Engine controller electronically controls supply pump, common rail, and injector. This function maintains optimum fuel injection amount and fuel injection timing.

Abbreviation	Actual word spelled out	Purpose of use (major applicable machine (*), or component/system)	Explanation
ECM	Electronic Control Module	Electronic control system	Electronic control device uses the signals from the sensors on the machine. These signals indicate the optimum actuation to the actuators. (Same as ECU)
ECMV	Electronic Control Modulation Valve	Transmission (D, HD, WA, etc)	Proportional electromagnetic valve that gradually increases oil pressure to engage clutch and reduces transmission shock.
ECSS	Electronically Controlled Suspension System	Travel (WA)	This system ensures smooth high-speed travel by absorbing vibration of machine during travel with hydraulic spring effect of accumulator.
ECU	Electronic Control Unit	Electronic control system	Electronic control device uses the signals from the sensors on the machine. These signals indicate the optimum actuation to the actuators. (Same as ECM)
EGR	Exhaust Gas Recirculation	Engine	This function recirculates part of exhaust gas to combustion chamber in order to reduce combustion temperature, controls emission of NOx.
EMMS	Equipment Management Monitoring System	Machine monitor	This system allows data (filter, oil replacement interval, malfunctions on machine, failure code, and failure history) from each sensor on the machine to be checked on the monitor.
EPC	Electromagnetic Proportional Control	Hydraulic system	This mechanism allows actuators to be operated in proportion to the current supplied.
FOPS	Falling Object Protective Structure	Cab and canopy	This structure protects the operator's head from falling objects. This performance is standardized as ISO 3449.
F-N-R	Forward-Neutral-Reverse	Operation	Forward - Neutral - Reverse
GPS	Global Positioning System	Communication (KOMTRAX, KOMTRAX Plus)	Global Positioning System: This system uses satellites to determine the current location on the earth.
GNSS	Global Navigation Satellite System	Communication (KOMTRAX, KOMTRAX Plus)	Global Navigation Satellite System: This system uses satellites such as GPS, GALILEO, etc. to determine the current location on the earth.
HSS	Hydrostatic Steering System	Steering (D)	This function uses a combination of hydraulic motor and bevel shaft to control difference in travel speed of right and left tracks. Accordingly machine can turn without using steering clutch.
HST	Hydro Static Transmission	Transmission (D, WA)	This function uses a combination of hydraulic pump and hydraulic motor for stepless shifting of the speed range without using gears.
ICT	Information and Communication Technology	Communication and electronic control	A general term for the engineering and its socially applied technology of information processing and communication.
IMA	Inlet Metering Actuator	Engine	This valve is installed at inlet port of pump, and it adjusts fuel intake amount in order to control fuel discharged volume of supply pump. (Same as IMV)

Abbreviation	Actual word spelled out	Purpose of use (major applicable machine (*), or component/system)	Explanation
IMU	Inertial Measurement Unit	Engine	This is a device to detect the angle (or angular velocity) and acceleration of the 3 axes that control motions.
IMV	Inlet Metering Valve	Engine	This valve is installed at inlet port of pump, and it adjusts fuel intake amount in order to control fuel discharged volume of supply pump. (Same as IMA)
KCCV	Komatsu Closed Crankcase Ventilation	Engine	This mechanism separates oil in blowby gas and returns it to the intake side to combust it there. It primarily consists of filters.
KCSF	Komatsu Catalyzed Soot Filter	Engine	This filter captures soot in exhaust gas. It is built in to KDPF.
KDOC	Komatsu Diesel Oxidation Catalyst	Engine	The catalyst is used for purifying exhaust gas. It is built in to KDPF or assembled with the muffler.
KDPF	Komatsu Diesel Particulate Filter	Engine	This component is used to purify the exhaust gas. KDOC (catalyst) and KCSF (filter to capture soot) are built-in it. It is installed in place of the conventional muffler.
KTCS	Komatsu Traction Control System	Travel and brake (HM)	This function recovers the drive force of the wheels by braking automatically with the optimum force and at the same time activates the inter-axle differential lock when the wheels idle while the machine travels on the soft ground road.
KVGT	Komatsu Variable Geometry Turbocharger	Engine	The turbocharger on which the cross-section area of the exhaust passage is made variable.
LCD	Liquid Crystal Display	Machine monitor	Image display equipment such as a monitor which assembles in the liquid crystal element.
LED	Light Emitting Diode	Electronic parts	It refers to semiconductor element that emits light when the voltage is applied in forward direction.
LIN	Local Interconnect Network	Communication and electronic control	One of communication standards that is used in the network on the machine.
LS	Load Sensing	Hydraulic system	Function that detects differential pressure of pump and controls discharged volume corresponding to load.
LVDS	Low Voltage Differential Signaling	Communication and electronic control	One of communication standards that is used in the network on the machine.
MAF	Mass Air Flow	Engine	This indicates engine intake air flow. It is not used independently but it is used as combined with sensor. Mass air flow sensor can be called as MAF sensor.
MMS	Multimedia Messaging Service	Communication	Service that allows transmission and reception of short messages consisting of characters or voice or images between cell phones.

Abbreviation	Actual word spelled out	Purpose of use (major applicable machine (*), or component/system)	Explanation
NC	Normally Closed	Electrical system, Hydraulic system	Characteristics of electrical or hydraulic circuits. Circuit is normally closed if it is not actuated, and it opens when it is actuated.
NO	Normally Open	Electrical system, Hydraulic system	Characteristics of electrical or hydraulic circuits. Circuit is normally open if it is not actuated, and it closes when it is actuated.
OLSS	Open-center Load Sensing System	Hydraulic system	Hydraulic system that can operate multiple actuators at the same time, regardless of the load.
PC	Pressure Compensation	Hydraulic system	A function used to correct oil pressure.
PCCS	Palm command control system	Steering (D)	System in which a controller instantly analyses data from each lever, pedal, and dial, and performs optimum electronic control of the engine and transmission.
PCV	Pre-stroke Control Valve	Engine	This valve is installed at inlet port of pump and it adjusts fuel intake amount in order to control fuel discharged volume of supply pump.
PPC	Proportional Pressure Control	Hydraulic system	This system is used for controlling proportional pressure. It moves actuators in proportion to the oil pressure.
PPM	Piston Pump and Motor	Hydraulic system (D, PC, etc)	Piston type hydraulic pump and motor.
PTO	Power Take Off	Power train system	Power take-off mechanism.
PTP	Power Tilt and power Pitch dozer	Work equipment (D)	This function performs hydraulic control of the tilt and pitch of the bulldozer blade.
ROPS	Roll-Over Protective Structure	Cab and canopy	If a machine tips over, this structure protects the operator wearing a seatbelt from being crushed. (Operator Protective structure when tipping) This performance is standardized as ISO 3471.
SCR	Selective Catalytic Reduction	Urea SCR system	It is exhaust gas purifier using urea water converts nitrogen oxides (NO _x) to harmless nitrogen and water by oxidation-reduction reaction. It may also be mentioned as exhaust gas purification catalyst or part of the name of related devices.
SI	Le Systeme International d' Unites (International unit system)	Unit	Abbreviation for "Le Systeme International d' Unites". It is the universal unit system and "a single unit for a single quantity" is the basic principle applied.
SOL	Solenoid	Electrical system	It refers to an actuator consisting of a solenoid and an iron core that is moved by the magnetic force when the solenoid is energized.
TWV	2-Way Valve	Hydraulic system	Solenoid valve that switches over direction of flow.

*1: Code for applicable machine model

D: Bulldozer

HD: Dump truck

HM: Articulate dump truck

LL: Log Loader

PC: Hydraulic excavator

RB: Road Builder

WA: Wheel loader

List of abbreviations used in the circuit diagrams

Abbreviation	Actual word spelled out
A/C	Air Conditioner
A/D	Analogue-to-Digital
A/M	Air Mix Damper
ACC	Accessory
ADD	Additional
AUX	Auxiliary
BR	Battery Relay
CW	Clockwise
CCW	Counter Clockwise
ECU	Electronic Control Unit
ECM	Electronic Control Module
ENG	Engine
EXGND	External Ground
F.G.	Frame Ground
GND	Ground
IMA	Inlet Metering Actuator
NC	No Connection
S/T	Steering
STRG	
SIG	Signal
SOL	Solenoid
STD	Standard
OPT	Option
OP	
PRESS	Pressure
SPEC	Specification
SW	Switch
TEMP	Temperature
T/C	Torque Converter
T/M	Transmission

FOREWORD, SAFETY, BASIC INFORMATION

HOW TO READ THE SHOP MANUAL

REMARK

- Some of the attachments and options described in this shop manual may not be available in some areas. If they are required, consult your Komatsu distributor.
- The materials and specifications are subject to change without notice.
- Shop Manuals are available for "machine part" and "engine part". For the engine unit, see the shop manual for the machine which has the same engine model.
- Actual machine may differ from the images which are contained in this manual. A typical model is shown in the illustrations of this shop manual.

Composition of the shop manual

This shop manual contains technical information necessary to perform services in workshops. It is divided into the following chapters for the ease of use.

00 INDEX AND FOREWORD

This section describes the index, foreword, safety, and basic information.

01 SPECIFICATIONS

This section describes the specifications of the machine.

10 STRUCTURE AND FUNCTION

This section describes the structure and operation of each component with respect to each system. "STRUCTURE AND FUNCTION" is helpful in not only understanding the structure of each component but performing troubleshooting.

20 STANDARD VALUE TABLE

This section describes the standard values for new machine and failure criteria for testing and adjusting, and troubleshooting. Use the standard values table to check the standard values for testing and adjusting, and judge troubles in troubleshooting.

30 TESTING AND ADJUSTING

This section describes the measuring tools and measuring methods for testing and adjusting as well as the adjusting method of each part. The standard values and repair limit for TESTING AND ADJUSTING are described in "STANDARD VALUE TABLE".

40 TROUBLESHOOTING

This section describes troubleshooting of failure part and its remedy method on the occurrence of the failure. Descriptions of troubleshooting are sorted by failure mode.

50 DISASSEMBLY AND ASSEMBLY

This section describes the special tools, work procedures, and safety precautions necessary for removal, installation, disassembly, and assembly of the components and parts. In addition, tightening torques, quantity, and weight of the coating materials, lubricants, and coolant necessary to these works are shown.

60 MAINTENANCE STANDARD

This section describes the maintenance standard value of each component. The maintenance standard shows the criteria and remedies for disassembly and assembly.

80 THE OTHER INFORMATION









This section describes the structure and function, testing and adjusting, and troubleshooting for all of the other components or equipment which cannot be separately classified in the appendix.

90 Circuit diagrams

This section describes hydraulic circuit diagrams and electrical circuit diagrams.

Symbols

Important safety and quality portions are marked with the following symbols so that shop manual is used effectively.

Symbol	Item	Remark
	Danger	This signal indicates an extremely hazardous situation which will result in death or serious injury if it is not avoided.
	Warning	This signal indicates a potentially hazardous situation which will result in death or serious injury if it is not avoided.
	Caution	This signal indicates a potentially hazardous situation which will result in injury or property damage around the machine if it is not avoided.
	Weight	This signal indicates the weight of parts and components, and items which requires great attention to a selection of wires and working posture for slinging work.
	Tightening torque	This signal indicates the tightening torque for portions which requires special care in assembling work.
	Coat	This signal indicates a place to be coated with adhesive, grease, etc. in assembling work.
	Oil and coolant	This signal indicates a place to supply oil, coolant, etc. and the quantity.
	Draining	This signal indicates a place to drain oil, coolant, etc. and the quantity.

Signal word



Signal word for notice and remark describes the following.

Symbol	Item	Remark
NOTICE	Notice	If the precaution of this signal word is not observed, the machine damage or shortening of service life may occur.
REMARK	Remark	This signal word contains useful information to know.

Unit

International System of Units (SI) is used in this manual. For reference, units that have been used in the past are given in { }.

SAFETY NOTICE FOR OPERATION

- Appropriate servicing and repair are extremely important to ensure safe operation of the machine. The shop manuals describe the effective and safe servicing and repair methods recommended by Komatsu. Some of the servicing and repair methods require the use of special tools designed by Komatsu for special purposes.
- The symbol mark  is indicated for such matters that require special precautions. The work indicated with this warning mark  should be performed according to the instructions with special attention. Should a hazardous situation occur or be anticipated during such work, be sure to keep safe first and take every necessary measures.

Safety matters

- Well organized work place
- Correct work clothes
- Observance of work standard
- Enforcement of hand signals
- Prohibition against unlicensed persons operating and handling the machine
- Safety check before starting work
- Wear of dust glasses (for cleaning or grinding work)
- Wear of welding goggles and protectors (for welding work)
- Being in good physical condition, and good preparation
- Always be alert and careful.

General precautions

 **If the machine is handled incorrectly, it is dangerous. Read and understand what is described in the operation and maintenance manual before operation. Read and understand what is described in this manual before operation.**

- Read and understand the meaning of all the safety labels stuck to the machine before performing any greasing or repairs. For the locations of the safety labels and detailed explanation of precautions, see Operation and Maintenance Manual.
- Tools and removed parts in the workshop should be well organized. Always keep the tools and parts in their correct places. Always keep the work area clean and make sure that there is no dust, dirt, oil, or water on the floor. Smoke only in the designated areas. Never smoke while working.
- Keep all tools in good condition, learn the correct way to use them, and use the proper ones. Check the tools, machine, forklift truck, service car, etc. thoroughly before starting the work.
- Always wear safety shoes and helmet when performing any operation. Do not wear loose clothes, or clothes with buttons missing.

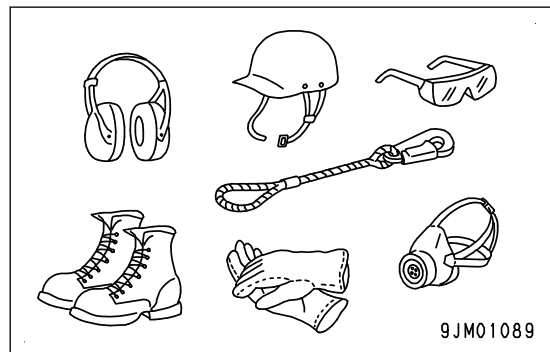

- Always wear the protective eyeglasses when hitting parts with a hammer.
- Always wear the protective eyeglasses when grinding parts with a grinder, etc.
- When performing any operation with multiple workers, always agree on the operating procedure before starting. Be clear in verbal communication, and observe hand signals. Hang "UNDER REPAIR" warning tag in the operator's compartment Before starting work.
- Work and operation which require license or qualification should be performed by qualified workers.
- Welding repairs should be performed by trained and experienced welders. When performing welding work, always wear welding gloves, apron, welding goggles, cap and other clothes suited for welding work.
- Warm up before starting the work with exercise which increases alertness and the range of motion in order to prevent injury.
- Avoid prolonged work, and take a rest at times to keep up a good condition. Take a rest at designated safe area.

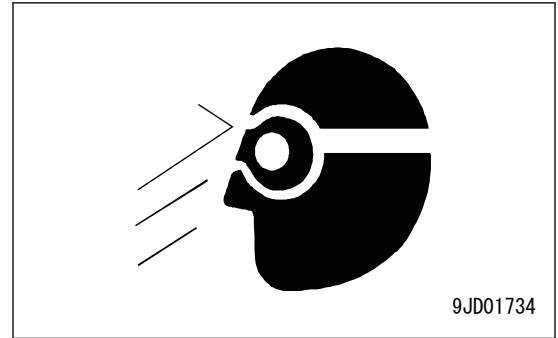

Precautions for preparatory work

- Place the machine on a firm and level ground, and apply the parking brake and chock the wheels or tracks to prevent the machine from moving before adding oil or making any repairs.
- Lower the work equipment (blade, ripper, bucket, etc.) to the ground before starting work. If this is not possible, insert the lock pin or use blocks to prevent the work equipment from falling. In addition, be sure to lock all the control levers and hang "UNDER REPAIR" warning tag on them.
- When performing the disassembling or assembling work, support the machine securely with blocks, jacks, or stands before starting the work.
- Remove all mud and oil from the steps or other places for going up and down on the machine. Always use the handrails, ladders or steps when for going up and down on the machine. Never jump on or off the machine. When the scaffold is not provided, use steps or stepladder to secure your footing. Do not use handrails, ladders, or steps if they are damaged or deformed. Repair it or replace it immediately.

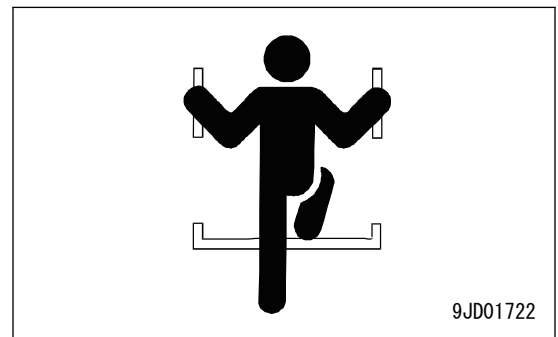

Precautions during work

- For the machine with the battery disconnect switch, check before starting the work that the system operating lamp is not lit. Then, turn the battery disconnect switch to OFF (○) position.

REMARK

Remove the key after it is turned to OFF (○) position if the battery disconnect switch is a switch key type. For the machine without the battery disconnect switch, turn the starting switch to OFF position, wait for two minutes or more before starting the work. Disconnect the battery cable by starting from the negative (-) terminal first.

- For the machine with the quick release battery terminal (-), check before starting the work that the system operating lamp is not lit. Then, disconnect the quick release battery terminal (-).

REMARK

For the machine without the system operating lamp, turn the starting switch to OFF position, wait for two minutes or more before starting the work. Disconnect the quick release battery terminal (-).

- Release the remaining pressure from the circuit before starting the work of disconnecting and removing of oil, fuel, water, or air from the circuit. When removing the cap of oil filter, drain plug, or oil pressure plug, it should be done slowly otherwise the oil spills.
- When removing or installing the checking plug or the piping in the fuel circuit, wait 30 seconds or longer after the engine is shut down and start the work after the remaining pressure is released from the fuel circuit.
- The coolant and oil in the circuits are hot when the engine is shut down. Be careful not to get scalded. Wait for the oil and coolant to cool before performing any work on the oil or coolant circuits.

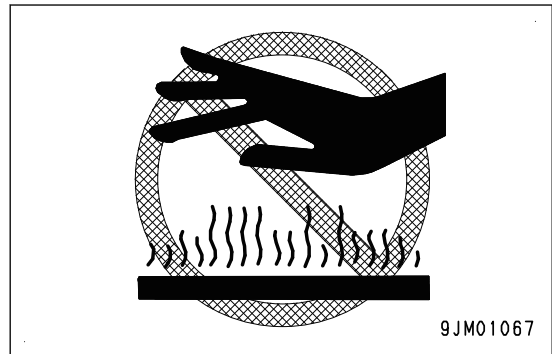
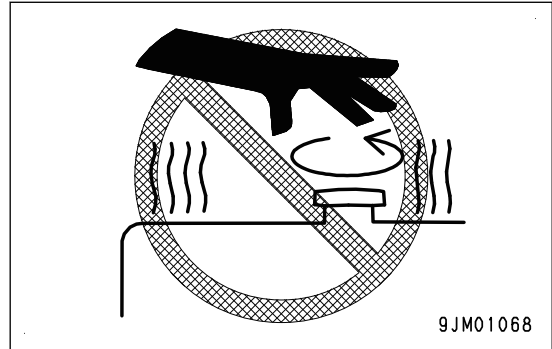

- Before starting work, shut down the engine. When working on or around a rotating part, in particular, shut down the engine. When checking the machine without shutting down the engine (measuring oil pressure, revolving speed, temperature, etc.), take extreme care not to get caught in rotating parts or moving parts.
- When raising a heavy component (heavier than 25 kg), use a hoist or crane. Before starting work, check that the slings (wire ropes, webbing slings, chains, and hooks) are free from damage. Always use slings which have ample capacity and install them to proper places. Operate the hoist or crane slowly to prevent the component from hitting any other part. Do not work with any part still raised by the hoist or crane.
- When removing a part which is under internal pressure or under reaction force of a spring, always leave 2 bolts in diagonal positions. Loosen those 2 bolts gradually and alternately to release the pressure, and then remove the part.
- When removing components, do not break or damage the electrical wiring. Damaged wiring may cause a fire.
- When removing piping, do not spill the fuel or oil. If any fuel or oil drips onto the floor, wipe it off immediately. Fuel or oil on the floor can cause you to slip and can even cause fires.
- Do not use gasoline to wash parts as a general rule. Do not use gasoline to clean electrical parts, in particular.

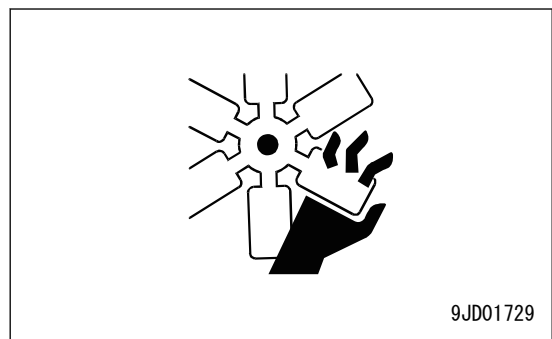
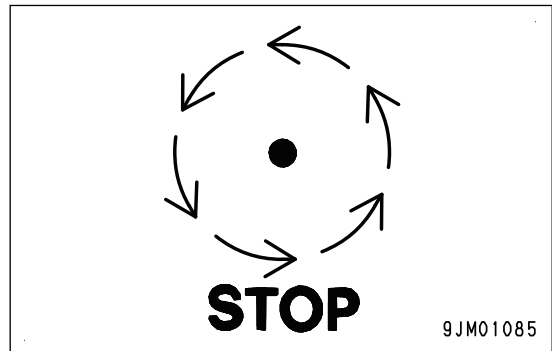

- Be sure to assemble all parts again in their original places. Replace any damaged parts and parts which must not be reused with new parts. When installing hoses and wiring harnesses, be sure that they will not be damaged by contact with other parts when the machine is operated.
- When installing high pressure hoses and tubes, make sure that they are not twisted. Damaged hoses and tubes are dangerous, so be extremely careful when installing hoses and tubes for high pressure circuits. In addition, check that high pressure hoses and tubes are correctly installed.
- When assembling or installing parts, always tighten them to the specified torques. When installing protective parts such as guards, or parts which vibrate violently or rotate at high speed, check again that they are installed correctly.
- Never insert your fingers or hand when aligning 2 holes. Be careful not to get your fingers caught in a hole.
- Check that the measuring tools are correctly installed when measuring hydraulic pressure.
- Take care when removing or installing the tracks of track-type machines. Since the track shoe may separate suddenly when you remove it, never let anyone stand at either end of the track shoe.
- If the engine is operated for a long time in a closed place with poor ventilation, it may cause gas poisoning. Open the windows and doors to ventilate the place well.



Precautions for slinging work and making signals

- Only one appointed worker must make signals and co-workers must communicate with each other frequently. The appointed signaler must make specified signals clearly at a place where he is well seen from the operator's seat and where he can see the working condition easily. The signaler must always stand in front of the load and guide the operator safely.
 - ⚠ **Never stand under the load.**
 - ⚠ **Do not move a load over a person.**
 - ⚠ **Never step on the load.**
 - ⚠ **Do not prevent the load from swinging or falling down by holding it simply with the hands.**
 - ⚠ **The sling workers and assistant workers other than the guide must move to a place where they are not caught between the load and materials or equipment on the ground or hit by the load even if the crane starts abruptly.**
- Check the slings before starting sling work.
- Keep putting on gloves during sling work. (Put on leather gloves, if available.)
- Measure the weight of the load by the eye and check its center of gravity.
- Use proper sling corresponding to the weight of the load and method of slinging. If too thick wire ropes are used to sling a light load, the load may slip and fall.
- Do not sling a load with 1 wire rope alone. If it is slung so, it may rotate and may slip out of the rope. Install 2 or more wire ropes symmetrically.
 - ⚠ **Slinging with one rope may cause turning of the load during hoisting, untwisting of the rope, or slipping of the rope from its original slinging position on the load, which can result in a dangerous accident.**
- Hanging angle must be 60 ° or smaller as a rule.
- When slinging a heavy load (25 kg or heavier), the hanging angle of the rope must be narrower than that of the hook.

REMARK

When slinging a load with 2 or more ropes, the force subjected to each rope increases with the hanging angle. The figure below shows the variation of allowable load in kN {kg} when slinging is made with 2 ropes, each of which is allowed to sling up to 9.8 kN {1000 kg} vertically, at various hanging angles. When the 2 ropes sling a load vertically, they can sling up to 2000 kg of total weight. This weight is reduced to 1000 kg when the 2 ropes make a hanging angle of 120°. If the 2 ropes sling a 2000 kg load at a hanging angle of 150°, each rope is subjected to a force as large as 39.2 kN {4000 kg}.

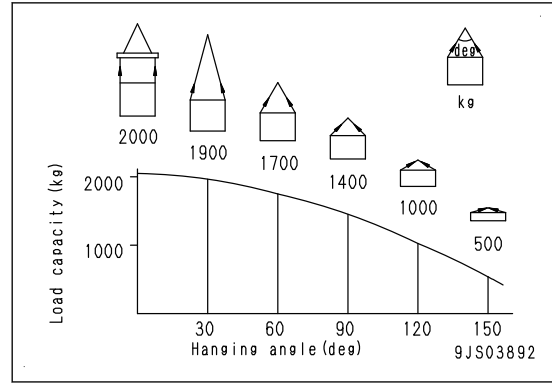

- When installing wire ropes to an angular load, apply pads to protect the wire ropes. If the load is slippery, apply proper material to prevent the wire rope from slipping.
- Use the specified eye bolts and fix wire ropes, chains, etc. to them with shackles, etc.
- Apply wire ropes to the middle part of the hook.

⚠ Do not use hooks if it does not have a latch system.

⚠ Slinging near the tip of the hook may cause the rope to slip off the hook during hoisting.

REMARK

The strength of the hook is maximum at its central part.

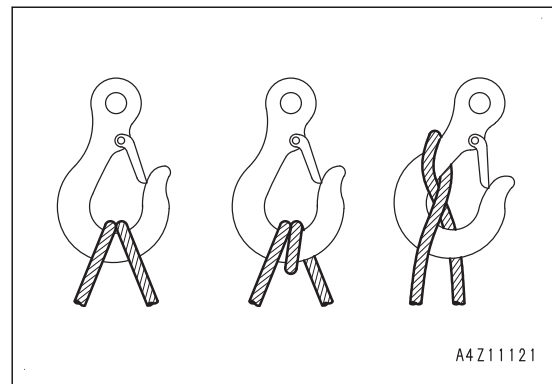

- Never use a wire rope which has breaks in strands (A), reduced diameter (B), or kinks (C). There is a danger that the rope may break during the towing operation.

Precautions for slinging up

- Wind in the crane slowly until wire ropes are stretched. When settling the wire ropes with the hand, do not grasp them but press them from above. If you grasp them, your fingers may be caught.
- After the wire ropes are stretched, stop the crane and check the condition of the slung load, wire ropes, and pads.

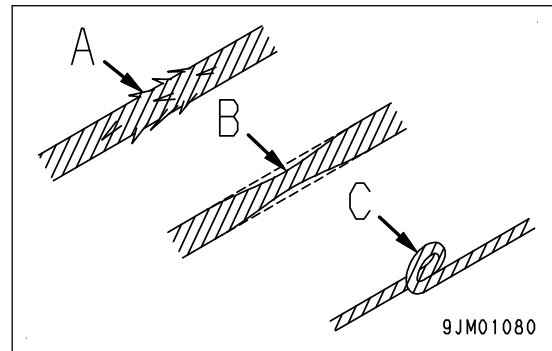

- If the load is unstable or the wire rope or chains are twisted, lower the load and lift it up again.
- Do not lift up the load at an angle.

Precautions for slinging down

- When slinging down a load, stop it temporarily at 30 cm above the floor, and then lower it slowly.
- Check that the load is stable, and then remove the sling.
- Remove kinks and dirt from the wire ropes and chains used for the sling work, and put them in the specified place.

Precautions for using mobile crane**REMARK**

Read Operation and Maintenance Manual of the crane carefully in advance and operate the crane safely.

Precautions for using overhead traveling crane

⚠ When raising a heavy component (heavier than 25 kg), use a hoist or crane.

REMARK

Weight of component whose weight is heavier than 25 kg is shown with symbol  in "DISASSEMBLY AND ASSEMBLY".

- Before starting work, check the wire ropes, brake, clutch, controller, rails, over winding prevention device, ground fault circuit interrupter for electric shock prevention, crane collision prevention device, and energizing caution lamp, and check the following safety items.
 - Observe the signals for sling work.
 - Operate the hoist at a safe place.
 - Be sure to check the directions of the direction indication plate (north, south, east and west) and the operating button.
 - Do not sling a load at an angle. Do not move the crane while the slung load is swinging.
 - Do not raise or lower a load while the crane is moving longitudinally or laterally.
 - Do not drag a sling.
 - When lifting up a load, stop it just after it becomes off the ground, check the safety, and then lift it up.
 - Consider the travel route in advance and lift up a load to a safe height.
 - Place the control switch in a position where it is not an obstacle to work and passage.
 - After operating the hoist, do not swing the control switch.
 - Remember the position of the main switch so that you can turn off the power immediately in an emergency.
 - If the hoist stops because of a power failure, turn off the main switch. When turning on a switch after it is turned off by the ground fault circuit interrupter, check that the devices related to that switch are not in operating condition.
 - If you find an obstacle around the hoist, stop the operation.
 - After finishing the work, stop the hoist at the specified position and raise the hook to at least 2 m above the floor. Do not leave the sling installed to the hook.

Selecting wire ropes

Select adequate ropes depending on the weight of the parts to be hoisted referring to the table below.

REMARK

The allowable load is calculated with one sixth (safety factor 6) of the breaking load of the rope.

Wire rope (JIS G3525 6x37-A type) (Standard Z twist wire ropes without galvanizing)

Nominal diameter of rope (mm)	Allowable load (kN { t })
10	8.8 {0.9}
12	12.7 {1.3}
14	17.3 {1.7}
16	22.6 {2.3}
18	28.6 {2.9}
20	35.3 {3.6}
25	55.3 {5.6}
30	79.6 {8.1}
40	141.6 {14.4}
50	221.6 {22.6}
60	318.3 {32.4}

Precautions for disconnecting air conditioner piping

NOTICE

When replacing the air conditioner unit, air conditioner compressor, condenser or receiver drier, etc., collect the refrigerant (air conditioner gas: R134a) from the air conditioner circuit before disconnecting the air conditioner hoses.

REMARK

- Ask a qualified person for collecting, adding and filling operations of the refrigerant (air conditioner gas: R134a).
- Never release the refrigerant (air conditioner gas: R134a) to the atmosphere.

⚠ Put on the protective eyeglasses, gloves and working clothes with long sleeves while you are collecting or filling the refrigerant. Otherwise, when refrigerant gas (R134a) gets in your eyes, you may lose your sight, and when it touches your skin, you may suffer from frostbite.

- When loosening the nuts fixing air conditioner hoses and tubes, be sure to use 2 wrenches; use one wrench to fix and use the other one to loosen the nut.

Precautions for air conditioner piping

- When installing the air conditioner piping, be careful so that dirt, dusts and water do not enter the hose.
- Check that the O-rings are fitted to the joints when connecting the air conditioner piping.
- Do not reuse an O-ring because it is deformed and deteriorated if it is used once.
- When removing the O-rings, use a soft tool so that the piping is not damaged.
- Check that the O-ring is not damaged or deteriorated.
- Apply compressor oil for refrigerant (R134a) to O-ring.

REMARK

Do not apply oil to the threaded portion of a bolt, nut or union.

Manufacturer	Part name
DENSO	ND-OIL8
VALEO THERMAL SYSTEMS	ZXL100PG (PAG46 or equivalent)
SANDEN	SP-10

When tightening nuts of the air conditioner hoses and tubes, be sure to use 2 wrenches. Use one wrench to fix and tighten the nut with the other wrench to the specified torque (Use a torque wrench for tightening).

REMARK

- The figure shows an example of fitting of O-ring.
- An O-ring is fitted to every joint of the air conditioner piping.

For tightening torques, see "PRECAUTIONS FOR DISCONNECTING AND CONNECTING HOSES AND TUBES IN AIR CONDITIONER PIPINGS (80-85)."

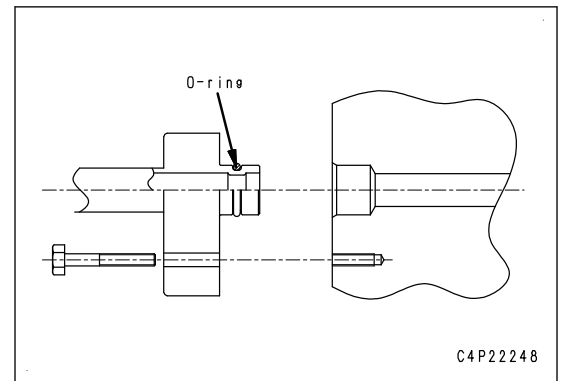
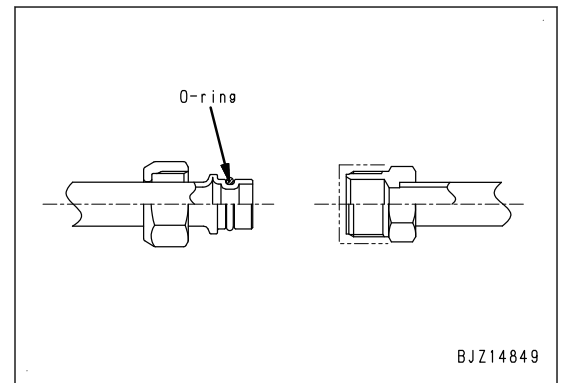

PRECAUTIONS TO PREVENT FIRE

Fire caused by fuel, oil, coolant or window washer fluid

Do not bring any open flame close to fuel, oil, coolant or window washer fluid. Always observe the following.

- Do not smoke or use any open flame near fuel or other flammable substances.
- Shut down the engine before adding fuel.
- Do not leave the machine when adding fuel or oil.
- Tighten all the fuel and oil caps securely.
- Be careful not to spill fuel on overheated surfaces or on parts of the electrical system.
- After adding fuel or oil, wipe up any spilled fuel or oil.
- Put greasy rags and other flammable materials into a safe container to maintain safety at the workplace.
- When washing parts with oil, use a non-flammable oil. Do not use diesel oil or gasoline. There is danger that they may catch fire.
- Do not weld or use a cutting torch to cut any pipes or tubes that contain flammable liquids.
- Determine well-ventilated areas for storing oil and fuel. Keep the oil and fuel in the specified place and do not allow unauthorized persons to enter.
- When performing grinding or welding work on the machine, move any flammable materials to a safe place before starting.

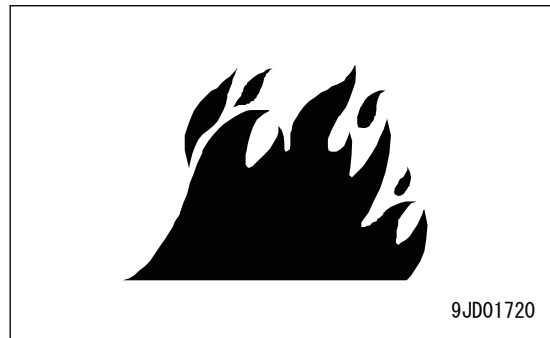

Fire caused by accumulation or attachment of flammable material

- Remove any dry leaves, chips, pieces of paper, coal dust, or any other flammable materials accumulated or attached to or around the engine exhaust manifold, muffler, or battery, or on the undercovers.
- To prevent fires from being caught, remove any flammable materials such as dry leaves, chips, pieces of paper, coal dust, or any other flammable materials accumulated around the cooling system (radiator, oil cooler) or on the undercover.

Fire coming from electric wiring

Short circuits in the electrical system can cause fire. Always observe the following.

- Keep all the electric wiring connections clean and securely tightened.
- Check the wiring every day for looseness or damage. Reconnect any loose connectors or refasten wiring clamps. Repair or replace any damaged wiring.

Fire caused by piping

Check that all the clamps for the hoses and tubes, guards, and cushions are securely fixed in position.

If they are loose, they may vibrate during operation and rub against other parts. There is danger that this may lead to damage to the hoses and cause high-pressure oil to spurt out, leading to fire and serious personal injury or death.

Fire around the machine due to highly heated exhaust gas

This machine is equipped with KDPF (Komatsu Diesel Particulate Filter).

KDPF is a system for purifying exhaust gas by removing soot in exhaust gas. In the process of purification (regeneration), the temperature of discharged exhaust gas may be higher than that of conventional models. Do not bring any flammable materials close to exhaust pipe outlet.

- When there are thatched houses, dry leaves or pieces of paper near the work site, set the system to disable the regeneration before starting work to prevent fire hazards due to highly heated exhaust gas caused by KDPF regeneration.
See the Operation and Maintenance Manual for the setting procedure.

Explosion caused by lighting equipment

- When checking fuel, oil, battery electrolyte, or coolant, always use lighting equipment with anti-explosion specifications.
- When taking the electrical power for the lighting equipment from the machine, follow the instructions in the Operation and Maintenance Manual.

ACTIONS IF FIRE OCCURS

- Turn the starting switch to OFF position to stop the engine.
- Use the handrails and steps to get off the machine.
- Do not jump off the machine. You may fall and suffer serious injury.
- The fumes generated by a fire contain harmful materials which have a bad influence on your body when they are inhaled.
Do not breathe the fumes.
- After a fire, there may be harmful compounds left. If they touch your skin they may have a bad influence on your body.
Be sure to wear rubber gloves when handling the materials left after the fire.
The material of the gloves, which is recommended is polychloroprene (Neoprene) or polyvinyl chloride (in the lower temperature environment).
When wearing cotton work gloves, wear rubber gloves under them.

PRECAUTIONS FOR CAB TILTING

- Do not start the engine or unlock the PPC lock lever when the cab and riser are tilting.
- Do not enter the cab when the cab and riser are tilted.
- Do not tilt the cab and riser assembly when the machine is on a slope.
- Do not tilt the cab and riser assembly in windy conditions.
- When the tilt operation is being performed, ensure that the work equipment is in an extended position so that there is no chance of interference between the work equipment and the cab and riser assembly.

PRECAUTIONS FOR DISPOSING OF WASTE MATERIALS

To prevent pollution, pay full attention to the way to dispose of waste materials.

- Always drain the oil from your machine in containers. Never drain the oil and coolant directly onto the ground or dump into the sewage system, rivers, seas, or lakes.
- Obey appropriate laws and regulations when disposing of harmful objects such as oil, fuel, coolant, solvent, filters, batteries, and DEF.

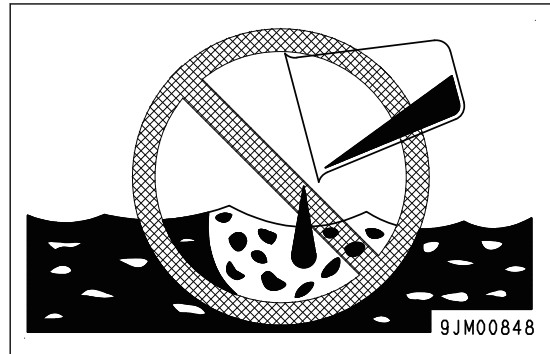

Avoid exposure to burning rubber or plastics which produce a toxic gas that is harmful to people.

- When disposing of parts made of rubber or plastics (hoses, cables, and harnesses), always comply with the local regulations for disposing industrial waste products.

ACTIONS TAKEN TO MEET EXHAUST GAS REGULATIONS

This machine conforms to either regulation of Tier4 Final (North America).

This machine is equipped with the following two exhaust gas treatment systems:

- **Komatsu Diesel Particulate Filter (hereafter KDPF):** A device which captures soot in the exhaust gas to purify exhaust gas. This process performs the combustion of soot referred to as "regeneration".
- **Urea SCR system:** A device which decomposes the toxic nitrogen oxides (NOx) mixed in the exhaust gas into harmless nitrogen and water. Spraying aqueous urea solution into the exhaust gas produces a reaction between the nitrogen oxides and ammonia generated from the urea solution and decomposes the nitrogen oxides into nitrogen and water.

DEF is the abbreviation for Diesel Exhaust Fluid and may be used as the aqueous urea solution for the SCR system. Commercial DEF that is API approved and meets all the requirements defined in ISO 22241-1. This solution will be represented as DEF throughout this manual.

About DEF

DEF is necessary for the urea SCR system. DEF is a colorless transparent 32.5% aqueous urea solution. Urea as main constituent is a material which is used for cosmetics, medical and pharmaceutical products, and fertilizer, etc.

If you add any additional additive agents or water to DEF and use it, the devices will not function properly, and conformance to the exhaust gas regulations will be lost. In addition, it will cause failure of the machine.

In North America, use DEF (Diesel Exhaust Fluid) which is certified by API (American Petroleum Institute). The certified DEF has the API DEF Certification Mark shown as follows. Look for the API DEF Certification Mark when purchasing DEF. API Diesel Exhaust Fluid Certification Mark is the trade mark of API (American Petroleum Institute).



PRECAUTIONS FOR DEF

GENERAL CHARACTER AND PRECAUTIONS FOR HANDLING

DEF is a colorless transparent 32.5% aqueous urea solution. Urea as main constituent is a material which is used for cosmetics, medical and pharmaceutical products, and fertilizer, etc. The following situations require immediate action:

- If it gets on your skin, it may cause inflammation. Immediately take the contaminated clothes or shoes off and wash it off with water. In addition, use a soap to wash it off thoroughly. If your skin becomes irritated or begins to hurt, immediately consult a doctor for treatment.
- Do not induce vomiting if swallowed. If swallowed, thoroughly rinse mouth with water and consult a doctor for treatment.
- Avoid contact with the eyes. If there is contact, flush with clean water for several minutes and consult a doctor for treatment.
- Wear protective eyeglasses when exposed to DEF to protect from solution splashing in your eyes. Wear rubber gloves when you perform work handling DEF to avoid skin contact.

PRECAUTIONS FOR ADDING

Do not put fluid other than DEF into DEF tank. If diesel fuel or gasoline is added into the tank, it can cause a fire. Some fluids or agents added can create and emit a toxic gas.

When opening the cap of DEF tank of the machine, the ammonia vapor may escape. Keep your face away from the filler port during opening or refilling.

PRECAUTIONS FOR STORING

If the temperature of DEF becomes high, harmful ammonia gas may be generated. Completely seal up its container for storage. When opening the container, perform it where there is good ventilation. For storage, see "STORE DEF (00-41)".

Store DEF avoiding direct sunlight. Always use the original container at the time of purchase. Do not exchange the container of DEF with another one. If DEF is stored in an iron or aluminum container, toxic gas may develop and a chemical reaction may corrode the container.

PRECAUTIONS FOR FIRE HAZARD AND LEAKAGE

DEF is non-flammable; however, in the case of a fire it may generate an ammonia gas. Act on the base of "Actions if fire occurs".

If DEF is spilled, immediately wipe and wash the area with water. If spilled DEF is left unattended and the area is not wiped and cleaned, toxic gas or corrosive substance may be produced by chemical reactions.

THE OTHER PRECAUTIONS

When disposing of DEF, treat it as an industrial waste. For the waste treating method, refer to "Precautions for disposing of waste materials". It should be treated in the same way.

Never use an iron or aluminum container when disposing DEF fluid, because toxic gas may develop and a chemical reaction may corrode the container. Use a container made of resin (PP, PE) or stainless steel when handling the fluid waste of DEF.

Do not touch any fluid discharged from urea SCR. This fluid becomes acid by the influence of sulphur in the fuel or built-in oxidation catalyzer. If it gets on your skin, thoroughly wash it off with water.

Never relocate or modify the exhaust gas after-treatment device. The harmful gas may be exhausted and it can cause serious damage to the environment as well as violation of laws.

STORE DEF

- If the temperature of DEF becomes high, harmful ammonia gas may be generated. Completely seal up its container for storage. Only open containers in a well-ventilated area.
- Store DEF avoiding direct sunlight. Always use the original container at the time of purchase. Do not exchange the container of DEF with another one. If DEF is stored in an iron or aluminum container, toxic gas may develop and a chemical reaction may corrode the container.
- DEF freezes at $-11\text{ }^{\circ}\text{C}$. The recommended temperature for storage is $-5\text{ }^{\circ}\text{C}$ or above.

The relation between the upper limit of storage temperature and the storage period of DEF is shown in the table.

Temperature of storage area	Storage period
Max.10 °C	Up to 36 months
Max.25 °C	Up to 18 months
Max.30 °C	Up to 12 months
Max.35 °C	Up to 6 months

*: Do not store DEF in the temperature of $35\text{ }^{\circ}\text{C}$ or above.

Handling DEF in cold weather

- DEF freezes at $-11\text{ }^{\circ}\text{C}$.
DEF may freeze and expand to break the devices and parts in the tank. The parts inside the tank may be affected. Add DEF to the specified amount for cold weather (below the level of when DEF may freeze).
- In cold weather, keep DEF or the machine installed with DEF in the indoors where the temperature is at $-11\text{ }^{\circ}\text{C}$ or higher to prevent DEF in the tank from freezing.

If DEF or the machine installed with DEF cannot be stored in the indoors where the temperature is at $-11\text{ }^{\circ}\text{C}$ or higher (if they are left outdoors in cold weather), DEF in the tank may freeze. Drain DEF to prevent it from freezing.

PRECAUTIONS FOR HANDLING HYDRAULIC EQUIPMENT

Because of the higher pressure and more precise hydraulic components, the most common cause of a failure is dust (foreign material) in the hydraulic circuit. The special care must be taken when adding hydraulic oil, or when disassembling, or assembling the hydraulic components.

Select an appropriate workplace

- In rain or high winds, or in dusty environment, avoid adding hydraulic oil, replacing filters, or repairing the machine.

Disassembly and maintenance work in the field

- In the field, there is a risk of dust entering the component during disassembling or maintenance work, and performance check is hardly performed. Replacement of the assembly is recommended.
- Perform disassembling and maintenance work in the dust proof area.

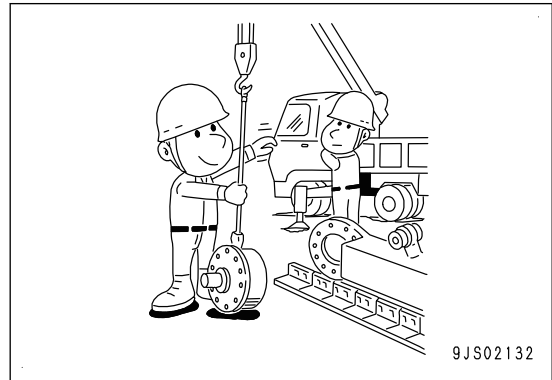

Sealing of openings (prevention of flowing out of oil)

Plug the openings of the piping and the device which have been removed to prevent foreign material from entering and oil from flowing out.

NOTICE

Do not expose the openings or stuff it, otherwise foreign material may enter or leaked oil may pollute the environment.

Do not discard the oil inconsiderately. Ask the customer for disposal or bring it back to dispose it appropriately.

REMARK

Cover the places tightly with caps, tapes, or plastic bags if it is hard to provide the plugs.

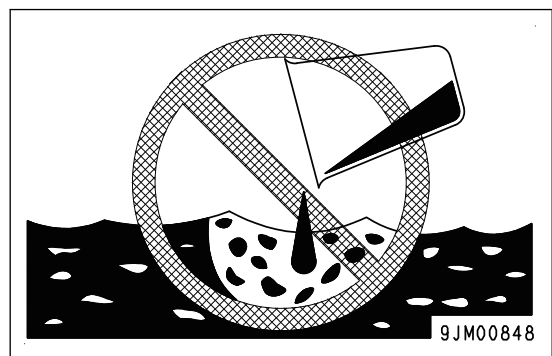

Preventing intrusion of foreign materials during refilling

- During refilling with the hydraulic oil, do not let water enter the electrical components.
- Clean the oil filler port and its around, refilling pump, oil jug, or etc.
- Refilling by using an oil cleaning device is better method since it can filtrate the contaminants accumulated in the oil during storage.

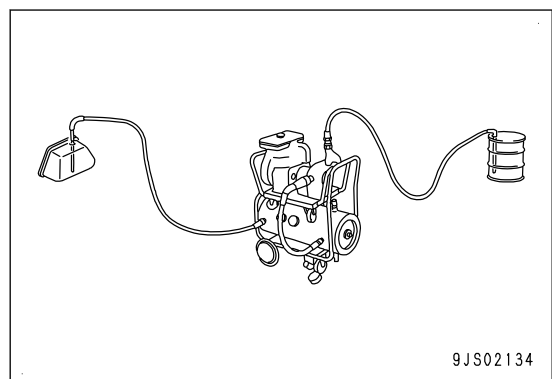

Replacing hydraulic oil while its temperature is high

- The higher the oil temperature is, the softer the oil is, and the smoother the oil runs. Also, the sludges are easily discharged from the circuit. Perform the replacement while oil temperature is high.
- Old hydraulic oil needs to be drained as much as possible when replacing.

NOTICE

Old hydraulic oil contaminates the new one if it is mixed since it contains contaminants and sludges, and the service life of the hydraulic oil is shortened.

REMARK

Drain the old hydraulic oil not only from the hydraulic tank but also from the filter and drain plug in the circuit.

Flushing operation

- Flushing is required to completely dislodge the contaminants and sludges, and existing oil containing those inside the hydraulic circuit after disassembling and assembling, and when replacing the oil with the new one.
- Normally, flushing is performed twice. Primary flushing is performed by using the flushing oil (1) and the secondary flushing is performed by using the specified hydraulic oil.

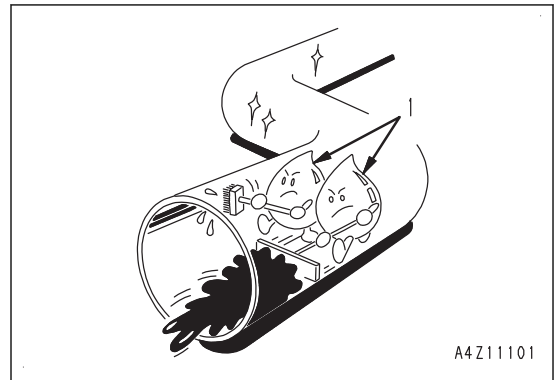

Cleaning operation

Perform oil cleaning to remove the contaminants and sludges in the hydraulic circuit after repair of the hydraulic device (pump, or control valve) or during operation of the machine.

REMARK

The oil cleaning equipment can remove the ultra fine (approximately 3 μm) particles that the filter built in the hydraulic equipment cannot remove. So, it is very effective device.

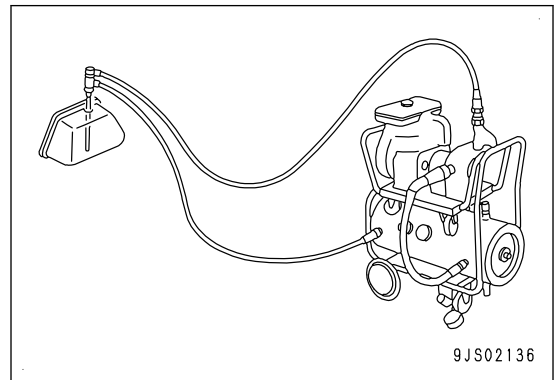

PRECAUTIONS FOR DISCONNECTION AND CONNECTION OF PIPINGS

When performing "testing and adjusting" of the machine, "removal and installation" and "disassembly and assembly" of the components, observe the following precautions.

Precautions for removal and disassembling work

- If the cooling water contains coolant, dispose of it correctly as chemicals. Do not drain it to the sewage rashly.
- After disconnecting the hoses or tubes, plug them to prevent dust from entering.
- When draining oil, prepare a container with sufficient capacity.
- Check the matchmarks which indicate the installing position, and put matchmarks on the places where they seem necessary before removal of the components to prevent any mistake when assembling.
- To prevent any excessive force from being applied to the wiring, always hold the connectors when disconnecting the connectors. Do not pull the wires.
- Attach the tags to wires and hoses so that installation is done to the correct installing positions.
- Check the thickness and number of shims when storing shims.
- When hoisting the components, prepare the slings with sufficient strength.
- When using forcing screws to remove any component, tighten the forcing screws uniformly and alternately.
- Before removing any component, clean the surrounding area and cover the component to prevent any foreign material from entering after removal.
- After disconnecting the piping or removing a pipe joint, install the following plugs.

NOTICE

When disassembling the machine, check the part number by referring to the Parts Book and use the appropriate parts according to the usage conditions.

REMARK

The part numbers of O-ring shown in the table indicate the temporary part number when disassembling and transporting the machine.

Introduction of parts for the disassembly of the face seal type hoses and tubes

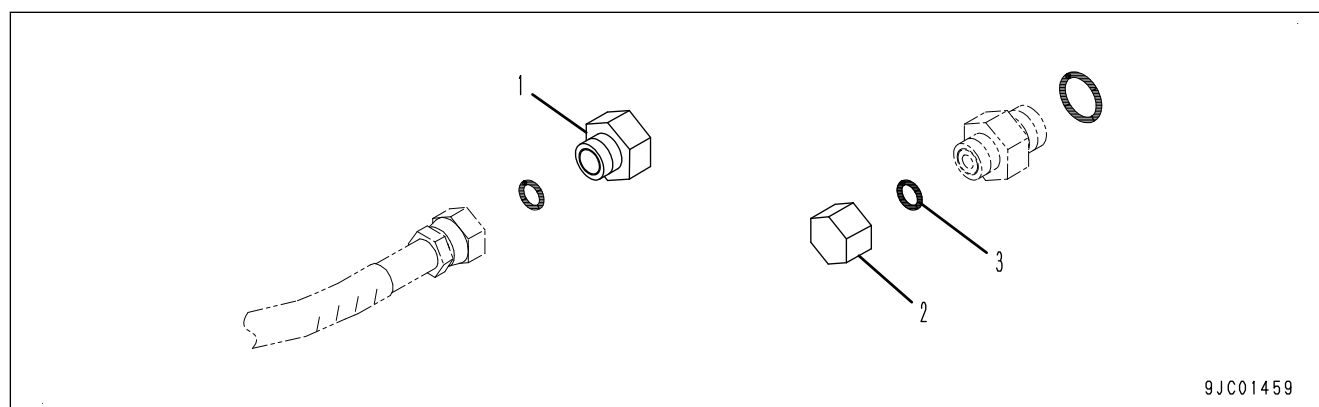

Nominal No.	Hose side	Pipe joint side	O-ring (3)
	Plug (1)	Nut (2)	
02	07376-70210	02789-00210	02896-11008
03	07376-70315	02789-00315	02896-11009
04	07376-70422	02789-00422	02896-11012
05	07376-70522	02789-00522	02896-11015
06	07376-70628	02789-00628	02896-11018

Introduction of parts for the disconnection of the taper seal type hoses and tubes

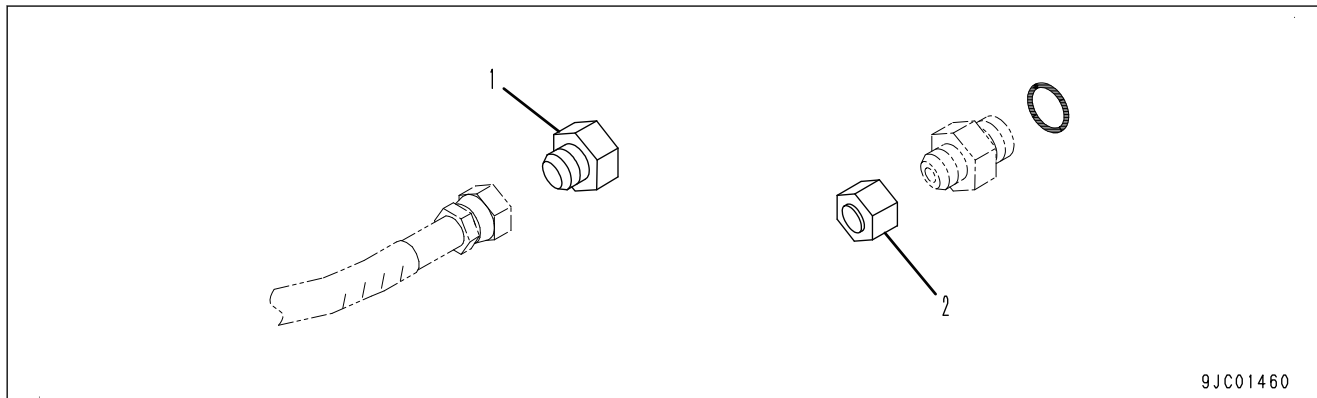

9JC01460

Nominal No.	Hose side	Pipe joint side
	Plug (1)	Nut (2)
02	07376-50210	07222-00210
03	07376-50315	07222-00312
04	07376-50422	07222-00414
05	07376-50522	07222-00515
06	07376-50628	07222-00616
10	07376-51034	07222-01018
12	07376-51234	07222-01219
14	07376-51443	07222-01422

Introduction of parts for the disconnection of the split flange type hoses and tubes

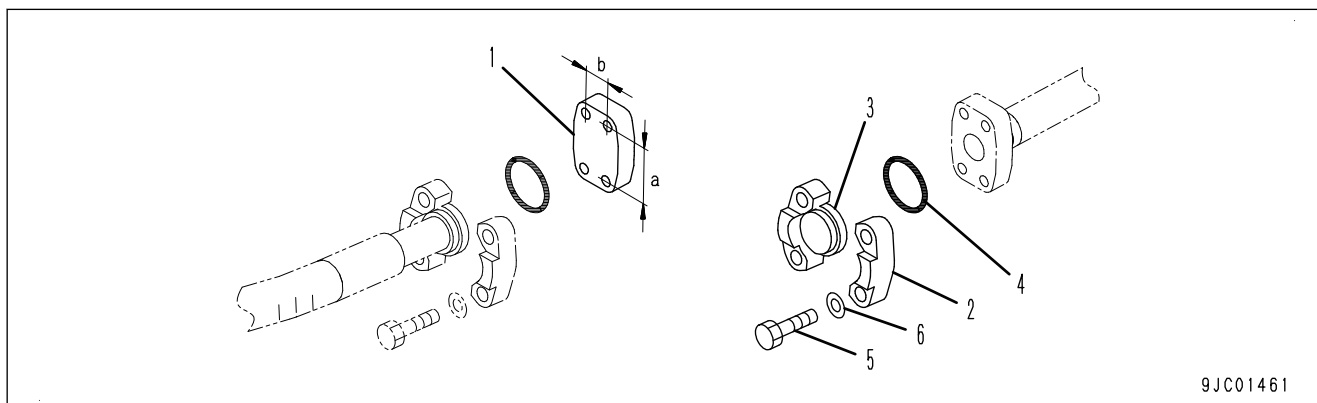

9JC01461

Nominal No.	Bolt pitch (mm)		Hose side	Tube side		O-ring (4)	Bolt (5)	Washer (6)
	a	b	Flange (1)	Split flange (2)	Sleeve head (3)			
04	38.1	17.5	07379-00400	07371-30400	07378-10400	07000-12021	01010-80825	01643-50823
05	42.9	19.8	07379-00500	07371-30500	07378-10500	07000-13022	01010-80830	01643-50823
06	47.6	22.2	07379-00640	07371-30640	07378-10600	07000-13025	07372-51035	01643-51032
10	52.4	26.2	07379-01044	07371-31049	07378-11000	07000-13032	07372-51035	01643-51032

Nominal No.	Bolt pitch (mm)		Hose side	Tube side		O-ring (4)	Bolt (5)	Washer (6)
	a	b	Flange (1)	Split flange (2)	Sleeve head (3)			
12	58.7	30.2	07379-01250	07371-31255	07378-11200	07000-13038	07372-51035	01643-51032
	66.7	31.8	07379-01260	07371-51260	07378-11210	07000-13038	01010-81245	01643-51232
14	69.9	35.8	07379-01460	07371-31465	07378-11400	07000-13048	07372-51240	01643-51232
	79.4	36.5	07379-01470	07371-51470	07378-11410	07000-13048	01010-81455	01643-31445
20	77.8	42.8	07379-02071	07371-32076	07378-12000	07000-12060	07372-51240	01643-51232
	96.8	44.5	07379-02080	07371-52080	07378-12010	07000-12060	01010-81865	01643-31845
24	88.9	50.8	07379-02484	07371-12484	07378-12400	07000-12070	07372-51240	01643-51232
30	106.4	62	07379-03010	07371-13010	07378-13000	07000-12085	07372-51650	01643-51645
34	120.6	69.8	07379-03411	07371-13411	07378-13400	07000-12100	07372-51650	01643-51645
40	130.2	77.8	07379-04012	07371-14012	07378-14000	07000-12110	07372-51650	01643-51645
50	152.4	92	07379-05011	07371-15011	07378-15000	07000-12135	07372-51655	01643-51645

Introduction of parts for the removal of O-ring boss type joint

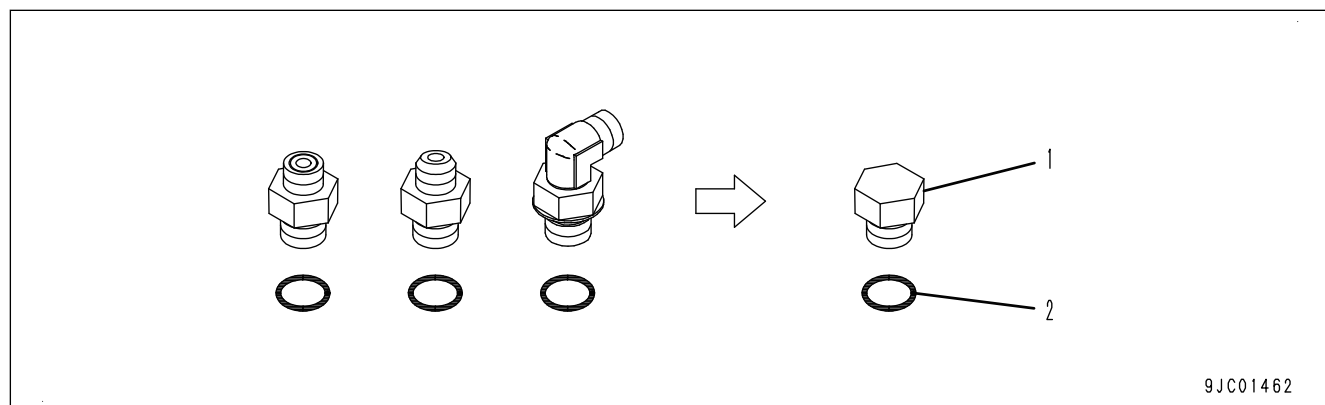

9JC01462

Nominal No.	Plug (1)	O-ring (2)
08	07040-10807	07002-10823
10	07040-11007	07002-11023
12	07040-11209	07002-11223
14	07040-11409	07002-11423
16	07040-11612	07002-11623
18	07040-11812	07002-11823
20	07040-12012	07002-12034
24	07040-12412	07002-12434
30	07041-13012	07002-13034
33	07040-13316	07002-13334
36	07041-13612	07002-13634
42	07040-14220	07002-14234
52	07040-15223	07002-15234

Introduction of parts for the removal of taper pipe thread type joint

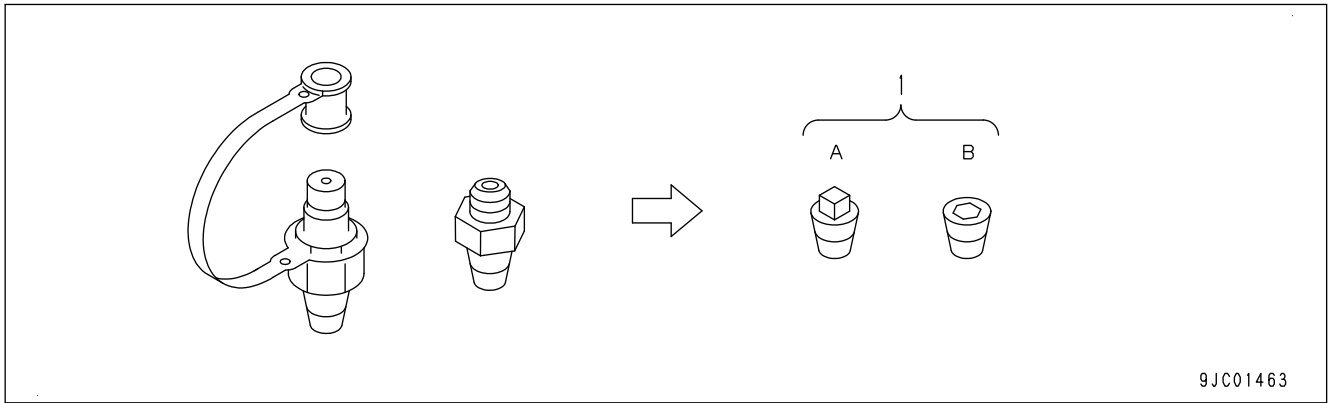

9JC01463

Nominal No.	Nominal thread size	Plug (1)	
		Square head type (A)	Hexagonal socket head (B)
01	R ¹ / ₈	07042-00108	07043-00108
02	R ¹ / ₄	07042-00211	07043-00211
03	R ³ / ₈	07042-00312	07043-00312
04	R ¹ / ₂	07042-00415	07043-00415
06	R ³ / ₄	07042-00617	07043-00617
10	R1	07042-01019	07043-01019
12	R1 ¹ / ₄	07042-01222	07043-01222
14	R1 ¹ / ₂	07042-01422	07043-01422
20	R2	07042-02026	07043-02026

Precautions for installation and assembling work

- Tighten the bolts and nuts (sleeve nuts) to the specified torque (KES) unless otherwise specified.
- Install the hoses without twist and interference. If there is any in-between clamp, securely fasten it.
- Replace all of the gaskets, O-rings, cotter pins, and lock plates with new ones.
- Bend the cotter pins and lock plates securely.
- When applying adhesive, clean and degrease the surface to apply, and apply 2 to 3 drops of adhesive to the threaded portion.
- When applying liquid gasket, clean and degrease the surface, and apply it uniformly after making sure that the surface is free from dust or damage.
- Clean all of the parts. If there is any damage, dents, burrs, or rust found on them, repair it.
- Apply engine oil to the rotating parts and sliding surface.
- Apply molybdenum disulfide lubricant (LM-P) to the surfaces of the press-fitting parts.
- After installing the snap ring, check that the snap ring is settled in the ring groove completely.
- When connecting wiring harness connectors, clean the connectors to remove oil, dust, or water, then connect them securely.
- Use the eye bolts without fatigue and deformation and screw them in securely. Match the directions of the eyes and the hook.
- When installing split flanges, tighten the bolts uniformly and alternately to prevent uneven tightening.
- As a rule, apply liquid gasket (LG-5) or liquid sealant (LS-2) to the threaded portion of each taper male screws which receive pressure.

REMARK

If the threaded portion is difficult to degrease, you may use a seal tape.

When winding a seal tape onto a right-handed taper male screw, start winding the screw clockwise from the third thread in the advancing direction of the threads seeing from the screw end.

NOTICE

If the seal tape is wound counterclockwise, it may become loose when screwed in, and it may come off. If the sealed tip is pushed outside, it may cause oil leakage.

NOTICE

When assembling the hydraulic equipment such as cylinders, pumps and pipings which are removed, be sure to bleed air from the hydraulic circuit before operating it for the first time according to the following procedure.

1. Start the engine, and run it at low idle.
2. Perform the operation to extend and retract each cylinder of the work equipment and stop it at approximately 100 mm before the stroke end for 4 or 5 times.
3. Perform the operation to extend and retract each cylinder of the work equipment and stop it at the stroke end for 3 or 4 times.

NOTICE

After repair is finished, when operating the machine which has been stored for a long period, bleed air from the hydraulic circuit according to the same procedure.

Precautions at the time of completion of work

Refilling of coolant or water or oil, greasing, and adding of DEF

- For machines with urea SCR system, fill DEF to the specified level before starting the engine.
- Supply the specified amount of grease to the work equipment parts.
- When the coolant is drained, be sure that the drain valve is securely tightened, then refill the coolant reservoir with the coolant Komatsu recommends to the specified level. Start the engine to circulate the coolant in the piping, and add the coolant to the specified level again.
- When the hydraulic components are removed and installed, refill the tank with the oil Komatsu recommends to the specified level. Start the engine to circulate the oil in the piping, and add the oil to the specified level again.
- If the hydraulic piping or hydraulic equipment is removed, be sure to bleed air from the system after rebuilding the parts, by referring to “30 TESTING AND ADJUSTING (30-1).”

Testing installed condition of cylinder heads and manifolds

- Check the cylinder head and intake and exhaust manifold mountings for looseness.
- If there is any looseness, retighten the part.

REMARK

For the tightening torques, see “50 DISASSEMBLY AND ASSEMBLY (50-1).”

Test engine piping for damage and looseness

Intake and exhaust system

Check that there is no damage on the pipings, or no looseness on mounting bolts, nuts and clamps, or no leak of air or exhaust gas from connecting portion.

If there is any looseness, damage, or gas leak, retighten or repair the part.

Cooling system

Check that there is no damage on the pipings, no looseness on mounting bolts, nuts and clamps, and no water leak from connecting portion.

If there is any looseness, damage, or water leak, retighten or repair the part.

Fuel system

Check that there is no damage on the pipings, no looseness on mounting bolts, nuts and clamps, and no fuel leak from connecting portion.

If there is any looseness, damage, or fuel leak, retighten or repair the part.

Check the exhaust equipment and its installation portion for looseness and damage.

REMARK

When an equipment is described as an exhaust equipment, it is one of the followings. (The applications or components of equipment are different depending on its models or specifications.)

- KDPF
- DEF mixing tube
- SCR assembly
- KDOC muffler
- Muffler
- Exhaust pipe
- Parts which connects the above, or etc.

Visually check that there is no crack or no damage on the exhaust equipment and its installation portion. If there is any damage, replace the part.

Check that there is no looseness on the exhaust equipment and mounting bolts, nuts, and clamps on the installation portion.

If there is any looseness, retighten the part.

Check of function of muffler in exhaust system

REMARK

When an equipment is described as an muffler in exhaust system, it is one of the followings. (The applications or components of equipment are different depending on its models or specifications.)

- KDPF
- DEF mixing tube
- SCR assembly
- KDOC muffler
- Muffler
- Exhaust pipe
- Parts which connects the above, or etc.

Check that there is no unusual noise by comparing to it of the time when the machine was new.

If there is any unusual noise, repair KDPF or muffler, referring to “40 TROUBLESHOOTING (40-1)” and “50 DISASSEMBLY AND ASSEMBLY (50-1).”

PRECAUTIONS FOR HANDLING ELECTRICAL EQUIPMENT

To maintain the performance of the machine over a long period, and to prevent failures or troubles before they occur, correct "operation", "maintenance and inspection" "troubleshooting", and "repairs" must be performed. This section deals particularly with correct repair procedures for mechatronics components and is aimed at improving the quality of repairs. For this purpose, it describes the working procedures in "Handling of electrical equipment".

Handling wiring harnesses and connectors

- Wiring harnesses consist of wires connecting one component to another component, connectors used for connecting and disconnecting one wire from another wire, and protectors or tubes used for protecting the wires.
- Compared with other electrical components fitted in boxes or cases, wiring harnesses are likely to be directly affected by rain water, heat, or vibration. Furthermore, during inspection and repair operations, they are frequently removed and installed again, so they are likely to suffer deformation or damage. For this reason, it is necessary to be extremely careful when handling and maintenance of the wiring harnesses.
- If DEF is spilled over wiring harness and connectors, it may cause corrosion and defective contact. Be careful not to spill it over electrical equipment, wiring harness and connectors since DEF is strongly corrosive to metal.

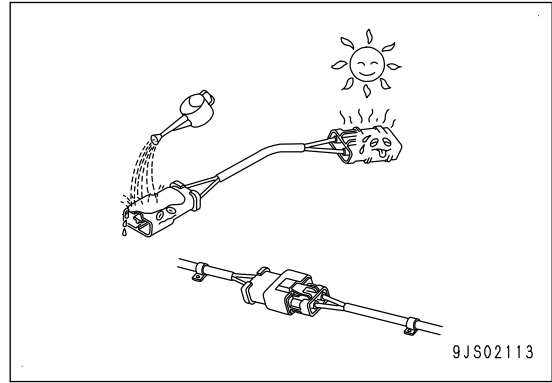

9JS02113

Main causes of failure in wiring harness

Defective contact of connectors (defective contact between male and female connectors)

Problems with defective contact are likely to occur because the male connector is not properly inserted into the female connector, or because one or both of connectors are deformed or the position is not correctly aligned, or because there is corrosion or oxidization of the contact surfaces. The corroded or oxidized contact surfaces may become shiny again (and contact may become normal) by connecting and disconnecting the connectors approximately 10 times.

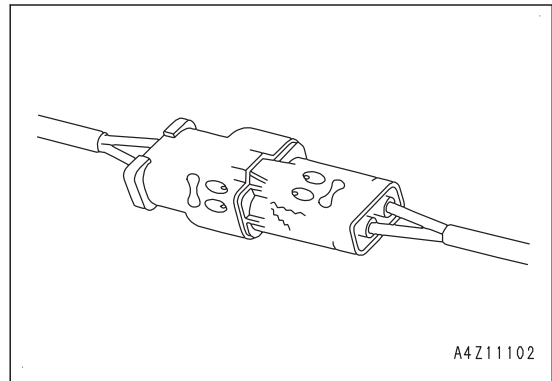

A4Z11102

Defective crimping or soldering of connectors

The pins of the male and female connectors are attached to wires by crimping or soldering. If excessive force is applied to the wire, the jointed portion (1) may become loose, and it may result in a defective connection or breakage.

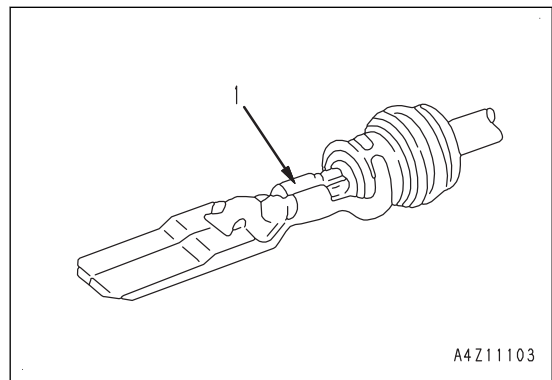

A4Z11103

Disconnection in wiring

If the wiring harness is pulled to disconnect the connector, or the components are lifted with a crane while the wiring harness is still connected, or a heavy object hits the wiring harness, it may separate the crimping of the connector, or damage the soldering, or break the wiring harness.

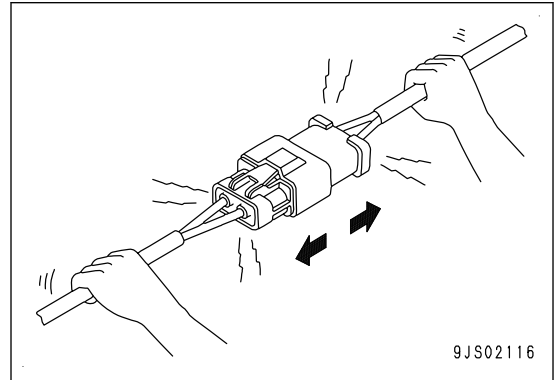

Water entering the connector by high-pressure jetting

The connector is designed to make it difficult for water to enter (drip-proof structure), but if high-pressure water is sprayed directly on the connector, water may enter the connector, depending on the direction of the water jet.

Do not spray water directly on the connector.

If the connector is waterproof, intruded water is hardly drained. Once water enters into the connector, water goes through pins to cause short-circuit. Drying the drenched connector or take appropriate actions before providing electricity.

Entry of water, dirt, or dust when disconnecting a connector

If any water, mud or dust is stuck to the outside surface of a connector, it can enter inside the connector when the connector is disconnected. Before disconnecting the connector, wipe off any stuck water or dirt by using a dry cloth or blow it with compressed air.

Oil, mud, or dust stuck to connector

If any oil or grease is stuck to the connector and an oil film is formed on the mating surface of the male and female pins, the oil prevents electricity from passing through resulting in defective contact. If any oil, grease, dirt or dust is stuck to the connector, wipe it off with a dry cloth or blow it with compressed air, and wash it with electrical contact restorer.

NOTICE

- When wiping the jointed portion of the connector, do not apply excessive force or deform the pins.
- If there is oil or water in the compressed air, it causes the contacts to become dirtier. Use clean air which any oil and water has been removed from.

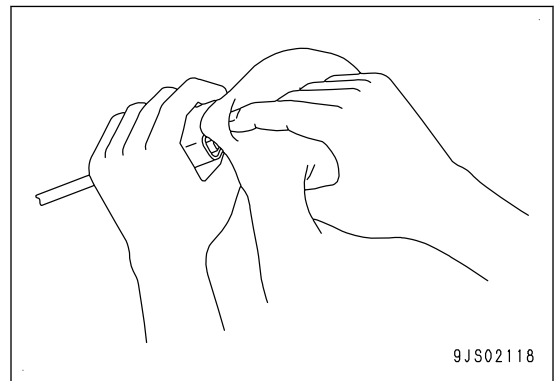
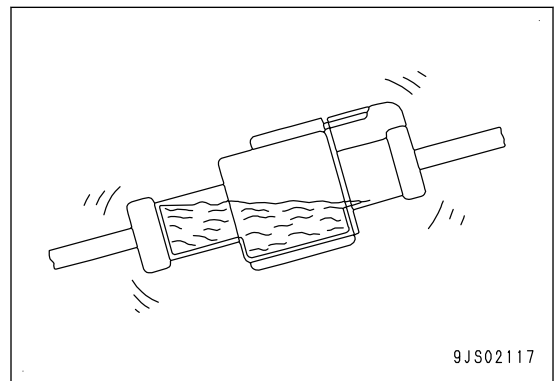

PRECAUTIONS FOR HANDLING FUEL SYSTEM EQUIPMENT

The machines equipped with common rail fuel injection system (CRI) consists of more precise parts than the parts used in the conventional fuel injection pump and nozzle. If foreign material enters this system, it may cause a failure. Use special care to prevent entry of the foreign material when servicing the fuel system.

Select an appropriate workplace

Avoid the work of adding hydraulic oil, replacing filters, or repairing the machine in rainy or windy weather, or in dusty environment.

Sealing the opening

Plug the removed pipes and the openings of the removed components with the caps, tapes, plastic bags, etc. to prevent foreign material from entering.

NOTICE

Do not expose the openings or stuff it, otherwise foreign material may enter or leaked oil may pollute the environment.

Do not discard the oil inconsiderately. Ask the customer for disposal or bring it back to dispose it appropriately.

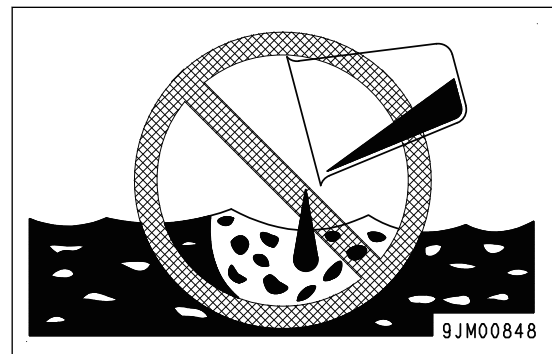

How to clean parts when dirt is stuck

If any dirt or dust sticks the parts of the fuel system, clean it off thoroughly with clean fuel.

Precautions for replacing fuel filter cartridge

Be sure to use the Komatsu genuine fuel filter cartridge.

NOTICE

The machine equipped with common rail fuel injection system (CRI) consists of more precise parts than the parts used in the conventional fuel injection pump and nozzle. In order to prevent foreign material from entering this system, the filter employs a specially high performance of filter element. If a filter other than a Komatsu genuine filter is used, fuel system contamination and damage may occur. Therefore Komatsu recommends using only Komatsu fuel filters and install them following the procedures in the shop manual.

PRECAUTIONS FOR HANDLING INTAKE SYSTEM EQUIPMENT

The machines equipped with Komatsu Variable Geometry Turbocharger (KVG) consists of more precise parts (variable system) than the parts used in the conventional turbocharger. If foreign material enters this system, it may cause a failure. Use special care to prevent entry of the foreign material when servicing the intake system.

Select an appropriate workplace

Avoid the work of adding hydraulic oil, replacing filters, or repairing the machine in rainy or windy weather, or in dusty environment.

Sealing the opening

Plug the removed pipes and the openings of the removed components with the caps, tapes, plastic bags, etc. to prevent foreign material from entering.

NOTICE

Do not expose the openings or stuff it, otherwise foreign material may enter it.

PRACTICAL USE OF KOMTRAX

Various information which KOMTRAX system transmits by using the radio communication is useful for KOMTRAX operator to provide various services for the customers.

When KOMTRAX system is installed to the machine and it is enabled, machine information can be checked by KOMTRAX system, and it is used for testing and troubleshooting to be performed efficiently.

Large-sized models are equipped with KOMTRAX Plus which can use more detailed information.

REMARK

(KOMTRAX may not be installed to the machine in some countries or areas.)

Merit of using KOMTRAX

- The location where the machine is working at can be checked on the map in a personal computer.
- Operation information such as service meter, operating hours, fuel consumption, and occurred caution as well as failure code can be checked.
- The operator can check the hours used and replacement interval of consumable parts of the machine such as fuel filter, hydraulic oil filter, hydraulic oil and engine oil.
- Information of how machine is operated (idling time, traveling time, digging time, relieving time, etc.) can be checked, and it is used to presume the machine operating condition.
- Various reports such as “Fuel saving operation support”, “Operation summary”, etc. is generated, and it is utilized as an advice tool for the user and operator.
- KOMTRAX Plus can record the data of abnormality record, trend data, snap shot data, etc. to grasp the soundness of machine, in addition to KOMTRAX function described above. These data can be used on personal computer screens.

How to make a full use of KOMTRAX

Making use of KOMTRAX enables the following activities.

- Quick response to a request for immediate repair
 1. To check the displayed caution and failure code, etc. through KOMTRAX upon receiving a repair request from a user.
 2. To immediately arrange necessary tools, replacement parts, etc, immediately in accordance with the displayed failure code.
 3. To find the location of the failed machine by using the map of KOMTRAX, to visit the customer there.
- Proactive maintenance
 1. To check the service summary screen of KOMTRAX, to find the machine which has high priority failure code indicated by a red or yellow flag.
 2. To check the condition of the machine with the customer and to make a plan to visit.
 3. To immediately arrange necessary tools, replacement parts, etc, immediately in accordance with the displayed failure code.
- Practice of periodic maintenance and periodic inspection service
 1. To check the service summary screen of KOMTRAX, and to find the machine of which the usage limits for the consumable parts indicated by red flags are over.
 2. To submit an estimate sheet for the consumable parts to be replaced and the labor cost for the replacement work to the customer.
 3. To propose the periodic inspection (Pm clinic, etc.) according to the service meter reading.

How to operate KOMTRAX

For the operating method of each screen of KOMTRAX, ask KOMTRAX key person in your Komatsu distributor.

DISCONNECT AND CONNECT PUSH-PULL TYPE COUPLER

REMARK

- Loosen the oil filler cap of the hydraulic tank slowly to release the remaining pressure in the hydraulic tank.
- Provide an oil container to receive oil since some hydraulic oil flows out when the hose is disconnected even after the remaining pressure is released from the hydraulic tank.

METHOD FOR DISCONNECTING AND CONNECTING TYPE 1 PUSH-PULL TYPE COUPLER

Disconnection

1. Hold adapter (1), and push hose joint (2) into mating adapter (3).

REMARK

- Push it in approximately 3.5 mm.
- Do not hold rubber cap portion (4).

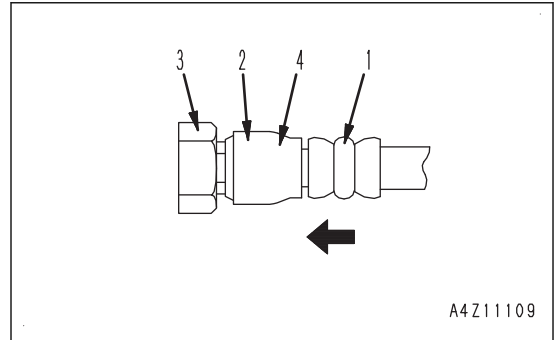

2. While having adapter (3) inserted into hose side joint (2), insert rubber cap (4) to adapter (3) side until it clicks.

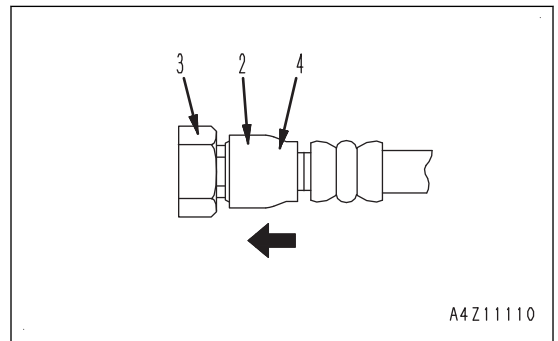

3. Hold hose adapter (1) or hose (5), and pull it out.

REMARK

Provide an oil container to receive a quantity of hydraulic oil which may flow out.

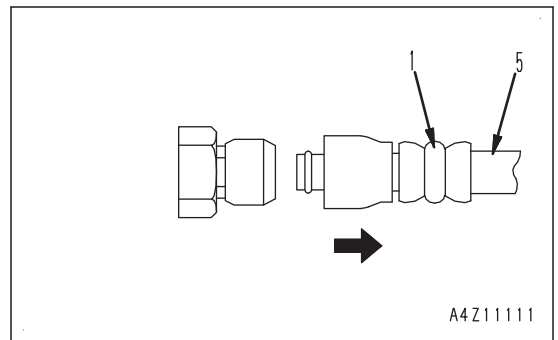

Connection

1. Hold hose adapter (1) or hose (5), and insert it in mating adapter (3), aligning the axis.

REMARK

Do not hold rubber cap portion (4).

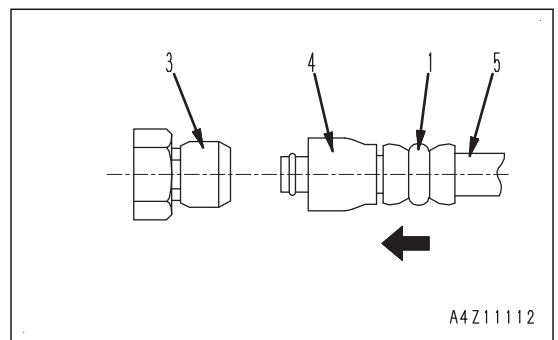

- After inserting the hose in the mating adapter perfectly, pull it back to check the connecting condition.

REMARK

When the hose fitting is pulled back, the rubber cap moves approximately 3.5 mm toward the hose, but it is not a problem.

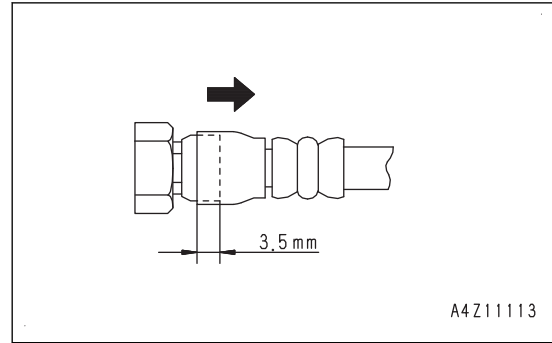

METHOD FOR DISCONNECTING AND CONNECTING TYPE 2 PUSH-PULL TYPE COUPLER

Disconnection

- Hold the tightening adapter part and push body (2) straight until sliding prevention ring (1) contacts contact surface (a) of the hexagonal part at the male end.

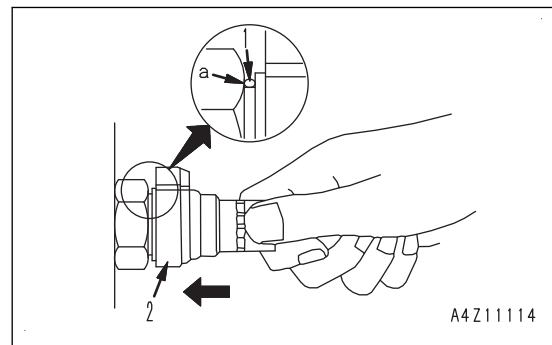

- While keeping the condition of step 1, turn lever (3) to the right (clockwise).

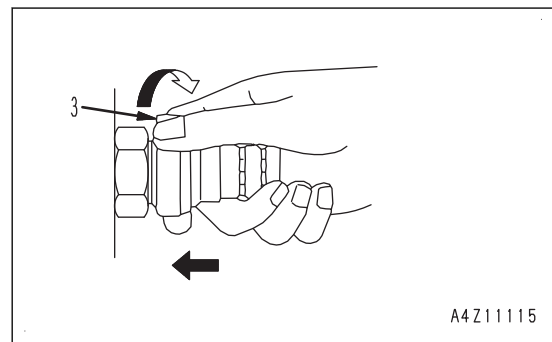

- While keeping the conditions of steps 1 and 2, pull out whole body (2) to disconnect it.

REMARK

Provide an container to receive a quantity of hydraulic oil which may flow out.

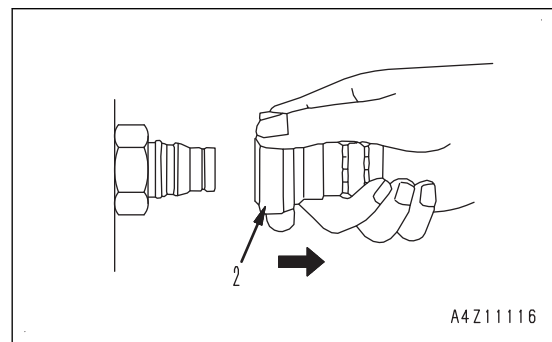

Connection

Hold the tightening adapter part, and push body (2) straight until sliding prevention ring (1) contacts contact surface (a) of the hexagonal part at the male end.

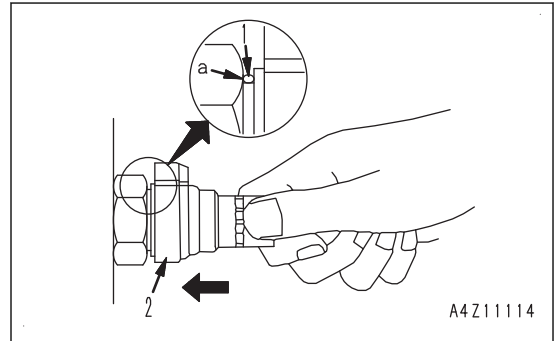

METHOD FOR DISCONNECTING AND CONNECTING TYPE 3 PUSH-PULL TYPE COUPLER

Disconnection

1. Hold the tightening adapter part and push body (2) straight until sliding prevention ring (1) contacts contact surface (a) of the hexagonal part at the male end.

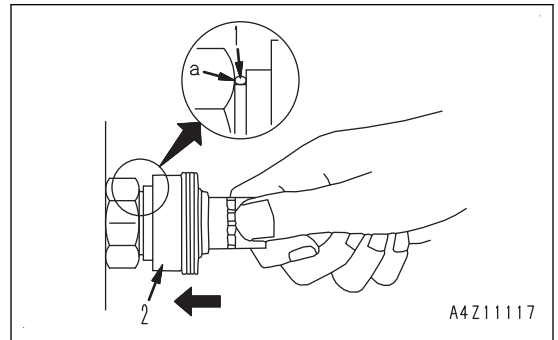

2. While keeping the condition of step 1, push cover (3) straight until it contacts contact surface (a) of the hexagonal portion on the male side.

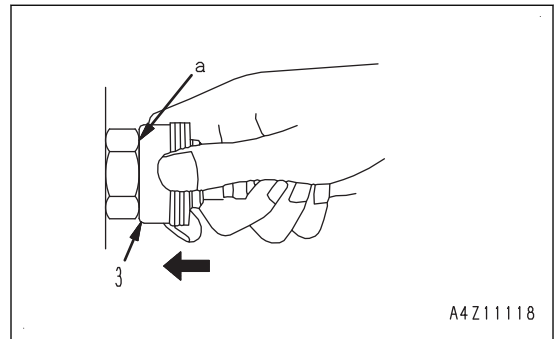

3. While keeping the conditions of steps 1 and 2, pull out whole body (2) to disconnect it.

REMARK

Provide an container to receive a quantity of hydraulic oil which may flow out.

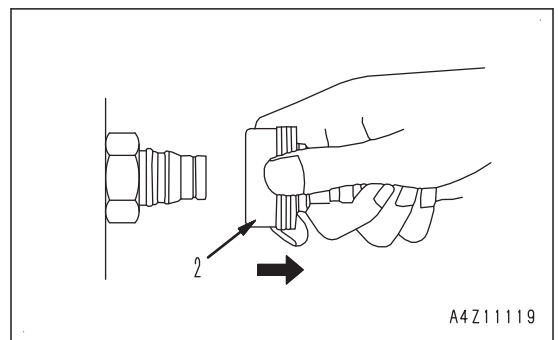

Connection

Hold the tightening adapter part, and push body (2) straight until sliding prevention ring (1) contacts contact surface (a) of the hexagonal part at the male end.

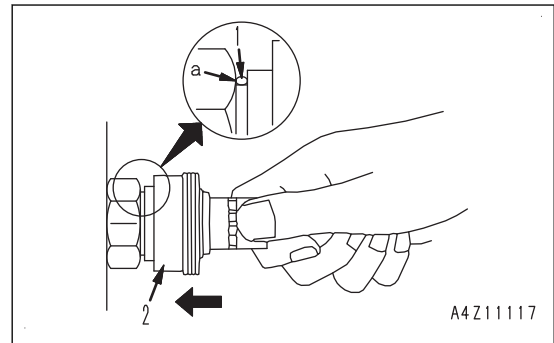

This as a preview PDF file from best-manuals.com



Download full PDF manual at best-manuals.com