

# SERVICE MANUAL

LOADER  
**TM320**

EN - 9813/2350 - ISSUE 5 - 01/2017

This manual contains original instructions, verified by the manufacturer (or their authorized representative).

Copyright 7-01-06 © JCB SERVICE  
All rights reserved. No part of this publication may be reproduced, stored in a retrieval system, or transmitted in any form or by any other means, electronic, mechanical, photocopying or otherwise, without prior permission from JCB SERVICE.

[www.jcb.com](http://www.jcb.com)

## Foreword

### The Operator's Manual

  
You and others can be killed or seriously injured if you operate or maintain the machine without first studying the Operator's Manual. You must understand and follow the instructions in the Operator's Manual. If you do not understand anything, ask your employer or JCB dealer to explain it.

Do not operate the machine without an Operator's Manual, or if there is anything on the machine you do not understand.

Treat the Operator's Manual as part of the machine. Keep it clean and in good condition. Replace the Operator's Manual immediately if it is lost, damaged or becomes unreadable.

### Contents

**01 - Machine**

**03 - Attachments, Couplings and Load Handling**

**06 - Body and Framework**

**09 - Operator Station**

**12 - Heating, Ventilating and Air-Conditioning (HVAC)**

**15 - Engine**

**18 - Fuel and Exhaust System**

**21 - Cooling System**

**24 - Brake System**

**25 - Steering System**

**27 - Driveline**

**30 - Hydraulic System**

**33 - Electrical System**

**72 - Fasteners and Fixings**

**75 - Consumable Products**

**78 - After Sales**



---

Notes:

---

---

---

---

---

---

---

---

---

---

---

---

---

---

---

---

---

---

---

---

---

---

---

---

---

---

 <p><b>SERVICE MANUAL</b> Volume 1</p> <p><b>TM320</b></p> <p>EN 9813/2350</p>	 <p><b>SERVICE MANUAL</b> Volume 2</p> <p><b>TM320</b></p> <p>EN 9813/2350</p>
 <p><b>SERVICE MANUAL</b> Volume 3</p> <p><b>TM320</b></p> <p>EN 9813/2350</p>	 <p><b>SERVICE MANUAL</b> Volume 4</p> <p><b>TM320</b></p> <p>EN 9813/2350</p>



---

Notes:

---

---

---

---

---

---

---

---

---

---

---

---



---

# 01 - Machine

<b>Contents</b>	<b>Page No.</b>
Acronyms Glossary .....	01-2
01-03 Safety	
01-03-03 Safety - Yours and Others .....	01-3
01-03-06 Safety Warnings .....	01-4
01-03-09 General Safety .....	01-5
01-03-12 Maintenance Safety .....	01-6
01-03-18 Operating Safety .....	01-8
01-03-21 Worksite Safety .....	01-10
01-03-24 Risk Assessment .....	01-11
01-03-27 Maintenance Positions .....	01-12
01-06 About this Manual	
01-06-06 Using the Manual .....	01-15
01-09 Description	
01-09-12 Main Component Locations .....	01-19
01-33 Cleaning	
01-33-00 General .....	01-21



---

## Acronyms Glossary

PIL      Parts Identification List



## 03 - Safety

Contents	Page No.
01-03-03 Safety - Yours and Others .....	01-3
01-03-06 Safety Warnings .....	01-4
01-03-09 General Safety .....	01-5
01-03-12 Maintenance Safety .....	01-6
01-03-18 Operating Safety .....	01-8
01-03-21 Worksite Safety .....	01-10
01-03-24 Risk Assessment .....	01-11
01-03-27 Maintenance Positions .....	01-12



---

Notes:

---

---

---

---

---

---

---

---

---

---

---

---



## **03 - Safety - Yours and Others**

### **Introduction**

All machinery can be hazardous. When a machine is correctly operated and maintained, it is a safe machine to work with. When it is carelessly operated or poorly maintained it can become a danger to you (the operator) and others.

In this manual and on the machine you will find warning messages, read and understand them. They inform you of potential hazards and how to avoid them. If you do not fully understand the warning messages, ask your employer or JCB dealer to explain them.

Safety is not just a matter of responding to the warnings. All the time you are working on or with the machine you must be thinking of what hazards there might be and how to avoid them.

Do not work with the machine until you are sure that you can control it.

Do not start any work until you are sure that you and those around you will be safe.

If you are not sure of anything, about the machine or the work, ask someone who knows. Do not assume anything.

Remember:

- Be careful
- Be alert
- Be safe.

## 06 - Safety Warnings

### Introduction

In this manual and on the machine, there are safety notices. Each notice starts with a signal word. The signal word meanings are given below.

The signal word 'DANGER' indicates a hazardous situation which, if not avoided, will result in death or serious injury.

The signal word 'WARNING' indicates a hazardous situation which, if not avoided, could result in death or serious injury.

The signal word 'CAUTION' indicates a hazardous situation which, if not avoided, could result in minor or moderate injury.

The signal word 'Notice' indicates a hazardous situation which, if not avoided, could result in machine damage.

The safety alert system (shown) also helps to identify important safety messages in this manual and on the machine. When you see this symbol, be alert, your safety is involved, carefully read the message that follows, and inform other operators.

**Figure 1. The safety alert system**



## **09 - General Safety**

### **Introduction**

#### **Training**

To operate the machine safely you must know the machine and have the skill to use it. You must abide by all relevant laws, health and safety regulations that apply to the country you are operating in. The operator's manual instructs you on the machine, its controls and its safe operation; it is not a training manual. If you are a new operator, get yourself trained in the skills of using a machine before trying to work with it. If you don't, you will not do your job well, and you will be a danger to yourself and others. In some markets and for work on certain jobsites you may be required to have been trained and assessed in accordance with an operator competence scheme. Make sure that you and your machine complies relevant local laws and jobsite requirements - it is your responsibility.

#### **Care and Alertness**

All the time you are working with or on the machine, take care and stay alert. Always be careful. Always be alert for hazards.

#### **Clothing**

You can be injured if you do not wear the correct clothing. Loose clothing can get caught in the machinery. Keep cuffs fastened. Do not wear a necktie or scarf. Keep long hair restrained. Remove rings, watches and personal jewellery.

#### **Alcohol and Drugs**

It is extremely dangerous to operate machinery when under the influence of alcohol or drugs. Do not consume alcoholic drinks or take drugs before or while operating the machine or attachments. Be aware of medicines which can cause drowsiness.

#### **Feeling Unwell**

Do not attempt to operate the machine if you are feeling unwell. By doing so you could be a danger to yourself and those you work with.

#### **Mobile Phones**

Switch off your mobile phone before entering an area with a potentially explosive atmosphere. Sparks in such an area could cause an explosion or fire resulting in death or serious injury.

Switch off and do not use your mobile phone when refuelling the machine.

#### **Lifting Equipment**

You can be injured if you use incorrect or faulty lifting equipment. You must identify the weight of the item to be lifted then choose lifting equipment that is strong enough and suitable for the job. Make sure that lifting equipment is in good condition and complies with all local regulations.

#### **Raised Equipment**

Never walk or work under raised equipment unless it is supported by a mechanical device. Equipment which is supported only by a hydraulic device can drop and injure you if the hydraulic system fails or if the control is operated (even with the engine stopped).

Make sure that no-one goes near the machine while you install or remove the mechanical device.

#### **Raised Machine**

Never position yourself or any part of your body under a raised machine which is not correctly supported. If the machine moves unexpectedly you could become trapped and suffer serious injury or be killed.

#### **Lightning**

Lightning can kill you. Do not use the machine if there is lightning in your area.

#### **Machine Modifications**

This machine is manufactured in compliance with prevailing legislative requirements. It must not be altered in any way which could affect or invalidate its compliance. For advice consult your JCB dealer.

## 12 - Maintenance Safety

### Introduction

#### Raised Machine

Never position yourself or any part of your body under a raised machine which is not correctly supported. If the machine moves unexpectedly you could become trapped and suffer serious injury or be killed.

#### Air Conditioning Maintenance

The air conditioning system is a closed loop system and contains pressurised refrigerant. No part of the system should be disconnected until the system has been discharged by a refrigeration engineer or a suitably trained person. You can be severely frostbitten or injured by escaping refrigerant.

#### Compressed Air

Compressed air is dangerous. Wear personal protective equipment. Never point a compressed air jet at yourself or others.

#### Springs

Always wear personal protective equipment when dismantling assemblies containing components under pressure from springs. This will protect against eye injury from components accidentally flying out.

#### Metal Splinters

You can be injured by flying metal splinters when driving metal pins in or out. Use a soft faced hammer or copper drift to remove and install metal pins. Always wear personal protective equipment.

#### Communications

Bad communications can cause accidents. If two or more people are working on the machine, make sure each is aware of what the others are doing. Before starting the engine make sure the others are clear of the danger areas. Examples of danger areas are: the rotating blades and belt on the engine, the attachments and linkages, and anywhere beneath or behind the machine. People can be killed or injured if these precautions are not taken.

#### Repairs

If your machine does not function correctly in any way, get it repaired straight away. Neglect of necessary repairs could result in an accident or affect your health. Do not try to do repairs or any other type of maintenance work you do not understand. To avoid injury and/or damage get the work done by a specialist engineer.

#### Hydraulic Pressure

Hydraulic fluid at system pressure can injure you. Before connecting or removing any hydraulic hose, residual hydraulic pressure trapped in the service hose line must be vented. Make sure the hose service line has been vented before connecting or removing hoses. Make sure the engine cannot be started while the hoses are open.

#### 'O' rings, Seals and Gaskets

Badly installed, damaged or rotted 'O' rings, seals and gaskets can cause leakages and possible accidents. Renew whenever disturbed unless otherwise instructed. Do not use Trichloroethane or paint thinners near 'O' rings and seals.

#### Arc Welding

To prevent the possibility of damage to electronic components, disconnect the battery and the alternator before arc-welding on the machine or attached implements.

If the machine is equipped with sensitive electrical equipment, i.e. amplifier drivers, electronic control units (ECUs), monitor displays, etc., then disconnect them before welding. Failure to disconnect the sensitive electrical equipment could result in irreparable damage to these components.

Parts of the machine are made from cast iron, welds on cast iron can weaken the structure and break. Do not weld cast iron. Do not connect the welder cable or apply any weld to any part of the engine.

Always connect the welder earth (ground) cable to the same component that is being welded to avoid damage to pivot pins, bearings and bushes. Attach the welder earth (ground) cable a distance from the part being welded no more than 0.6m.

#### Counterweights

Your machine may be installed with counterweights. They are extremely heavy. Do not attempt to remove them.

#### Accumulators

The accumulators contain hydraulic fluid and gas at high pressure. Prior to any work being carried out on systems incorporating accumulators, the system pressure must be discharged by a JCB dealer, as the sudden release of the hydraulic fluid or gas may cause injury.

#### Hot Components

Touching hot surfaces can burn skin. The engine and machine components will be hot after the unit has been running. Allow the engine and components to cool before servicing the unit.

#### Soft Ground

A machine can sink into soft ground. Never work under a machine on soft ground.

### **Working Under the Machine**

Make the machine safe before getting beneath it. Make sure that any attachments on the machine are correctly attached. Engage the park brake, remove the ignition key, disconnect the battery. If the machine has wheels use blocks to prevent unintentional movement.

### **Lifting the Machine**

Under no circumstances must the engine be run with the transmission in gear and only one driving wheel jacked clear of the ground, since the wheel on the ground will move the machine.

### **Chemicals**

Certain seals and gaskets (e.g. crankshaft oil seal) on JCB machines contain fluoroelastomeric materials such as Viton®, FluorelTM and Technoflon®. Fluoroelastomeric materials subjected to high temperatures can produce highly corrosive hydrofluoric acid. This acid can severely burn. New fluoroelastomeric components at ambient temperature require no special safety precautions. Used fluoroelastomeric components whose temperatures have not exceeded 300°C (571.6°F) require no special safety precautions. If evidence of decomposition (e.g. charring) is found, refer to the next paragraph for safety instructions. Do not touch component or surrounding area. Used fluoroelastomeric components subjected to temperatures greater than 300°C (571.6°F) (e.g. engine fire) must be treated using the following safety procedure. Make sure that heavy duty gloves and special safety glasses are worn: Thoroughly wash contaminated area with 10% calcium hydroxide or other suitable alkali solution, if necessary use wire wool to remove burnt remains. Thoroughly wash contaminated area with detergent and water. Contain all removed material, gloves etc. used in this operation in sealed plastic bags and dispose of in accordance with Local Authority Regulations. Do not burn fluoroelastomeric materials.

### **Hydraulic Hoses**

Never re-use hydraulic hose end crimps or use reusable hose end crimps.

### **Personal Protective Equipment**

Use the appropriate personal protective equipment before performing maintenance on the machine, otherwise you could be injured.

### **Working at Height**

Use appropriate access equipment such as ladders or a working platform if it is necessary to work at height to perform maintenance tasks on the machine. If you do not use suitable access equipment there is a risk of falling, resulting in personal injury or death.

## 18 - Operating Safety

### Introduction

#### Training

Make sure that you have had adequate training and that you are confident in your ability to operate the machine safely before you use it. Practice using the machine and its attachments until you are completely familiar with the controls and what they do. With a careful, well trained and experienced operator, your machine is a safe and efficient machine. With an inexperienced or careless operator, it can be dangerous. Do not put your life, or the lives of others, at risk by using the machine irresponsibly. Before you start to work, tell your colleagues what you will be doing and where you will be working. On a busy site, use a signalman.

Before doing any job not covered in this manual, find out the correct procedure. Your local JCB distributor will be glad to advise you.

#### Fuel

Fuel is flammable, keep naked flames away from the fuel system. Stop the engine immediately if a fuel leak is suspected. Do not smoke while refuelling or working on the fuel system. Do not refuel with the engine running. Completely wipe off any spilt fuel which could cause a fire. There could be a fire and injury if you do not follow these precautions.

#### Machine Condition

A defective machine can injure you or others. Do not operate a machine which is defective or has missing parts. Make sure the maintenance procedures in this manual are completed before using the machine.

#### Machine Limits

Operating the machine beyond its design limits can damage the machine, it can also be dangerous. Do not operate the machine outside its limits. Do not try to upgrade the machine performance with unapproved modifications or additional equipment.

#### Engine/Steering Failure

If the engine or steering fails, stop the machine as quickly as possible. Do not operate the machine until the fault has been corrected.

#### Exhaust Gases

Machine exhaust gases can harm and possibly kill you or bystanders if they are inhaled. Do not operate the machine in closed spaces without making sure there is good ventilation. If possible, install an exhaust extractor. If you begin to feel drowsy, stop the machine at once and get into fresh air.

#### Worksites

Worksites can be hazardous. Examine the site before working on it. You could be killed or injured if the ground gives way under your machine or if piled material collapses onto it. Check for potholes and hidden debris, logs, ironwork etc. Any of these could cause you to lose control of your machine. Check for utilities such as electric cables (overhead and underground), gas and water pipes etc. Mark the positions of the underground cables and pipes. Make sure that you have enough clearance beneath overhead cables and structures.

#### Communications

Bad communications can cause accidents. Keep people around you informed of what you will be doing. If you will be working with other people, make sure any hand signals that may be used are understood by everybody. Worksites can be noisy, do not rely on spoken commands.

#### Parking

An incorrectly parked machine can move without an operator. Follow the instructions in the Operator's Manual to park the machine correctly.

#### Banks and Trenches

Banked material and trenches can collapse. Do not work or drive too close to banks and trenches where there is danger of collapse.

#### Safety Barriers

Unguarded machines in public places can be dangerous. In public places, or where your visibility is reduced, place barriers around the work area to keep people away.

#### Sparks

Explosions and fire can be caused by sparks from the exhaust or the electrical system. Do not use the machine in closed areas where there is flammable material, vapour or dust.

#### Hazardous Atmospheres

This machine is designed for use in normal outdoor atmospheric conditions. It must not be used in an enclosed area without adequate ventilation. Do not use the machine in a potentially explosive atmosphere, i.e. combustible vapours, gas or dust, without first consulting your JCB dealer.

#### Regulations

Obey all laws, worksite and local regulations which affect you and your machine.

### **Electrical Power Cables**

You could be electrocuted or badly burned if you get the machine or its attachments too close to electrical power cables.

You are strongly advised to make sure that the safety arrangements on site comply with the local laws and regulations concerning work near electric power lines.

Before you start using the machine, check with your electricity supplier if there are any buried power cables on the site.

There is a minimum clearance required for working beneath overhead power cables. You must obtain details from your local electricity supplier.

### **Working Platform**

Using the machine as a working platform is hazardous. You can fall off and be killed or injured. Never use the machine as a working platform unless with approved man-basket or man-crate (if applicable).

### **Machine Safety**

Stop work at once if a fault develops. Abnormal sounds and smells can be signs of trouble. Examine and repair before resuming work.

### **Hot Components**

Touching hot surfaces can burn skin. The engine and machine components will be hot after the unit has been running. Allow the engine and components to cool before servicing the unit.

### **Travelling at High Speeds**

Travelling at high speeds can cause accidents. Always travel at a safe speed to suit working conditions.

### **Hillsides**

Operating the machine on hillsides can be dangerous if the correct precautions are not taken. Ground conditions can be changed by rain, snow, ice etc. Check the site carefully. When applicable, keep all attachments low to the ground.

### **Visibility**

Accidents can be caused by working in poor visibility. Use your lights to improve visibility. Keep the road lights, windows and mirrors clean.

Do not operate the machine if you cannot see clearly.

Modification of the machine's configuration by the user (e.g. the fitting of large and non-approved attachments) may result in a restriction of the machine visibility.

### **Hands and Feet**

Keep your hands and feet inside the machine.

When using the machine, keep your hands and feet clear of moving parts. Keep your hands and feet within the operator compartment while the vehicle is in motion.

### **Controls**

You or others can be killed or seriously injured if you operate the control levers from outside the machine. Operate the control levers only when you are correctly seated.

### **Passengers**

Passengers in or on the machine can cause accidents. Do not carry passengers.

### **Fires**

If your machine is equipped with a fire extinguisher, make sure it is checked regularly. Keep it in the correct machine location until you need to use it.

Do not use water to put out a machine fire, you could spread an oil fire or get a shock from an electrical fire. Use carbon dioxide, dry chemical or foam extinguishers. Contact your nearest fire department as quickly as possible. Firefighters must use self-contained breathing apparatus.

### **Roll Over Protection**

If the machine starts to roll over, you can be crushed if you try to leave the cab. If the machine starts to roll over, do not try and jump from the cab. Stay in the cab, with your seat belt fastened.

### **Confined Areas**

Pay extra attention to proximity hazards when operating in confined areas. Proximity hazards include buildings, traffic and bystanders.

### **Safe Working Loads**

Overloading the machine can damage it and make it unstable. Study the specifications in the Operator's Manual before using the machine.

### **Lightning**

If you are inside the machine during a lightning storm stay in the machine until the storm has passed. If you are outside of the machine during a lightning storm stay away from the machine until the storm has passed. Do not attempt to mount or enter the machine.

If the machine is struck by lightning do not use the machine until it has been checked for damage and malfunction by trained personnel.

## 21 - Worksite Safety

### Introduction

**▲ WARNING** You or others can be killed or seriously injured if you do unfamiliar operations without first practising them. Practise away from the worksite on a clear area. Keep other people away. Do not perform new operations until you are sure you can do them safely.

**WARNING** There could be dangerous materials such as asbestos, poisonous chemicals or other harmful substances buried on the site. If you uncover any containers or you see any signs of toxic waste, stop the machine and advise the site manager immediately.

**WARNING** Before you start using the machine, check with your local gas company if there are any buried gas pipes on the site.

If there are buried gas pipes we recommend that you ask the gas company for any specific advice regarding the way you must work on the site.

Some modern gas pipes cannot be detected by metal detectors, so it is essential that an accurate map of buried gas pipes is obtained before any excavation work commences.

Hand dig trial holes to obtain precise pipe locations. Any cast iron pipes found must be assumed to be gas pipes until contrary evidence is obtained.

Older gas pipes can be damaged by heavy vehicles driving over the ground above them.

Leaking gas is highly explosive.

If a gas leak is suspected, contact the local gas company immediately and warn all personnel on the site. Ban smoking, make sure that all naked lights are extinguished and switch off any engines which may be running.

You are strongly advised to make sure that the safety arrangements on site comply with the local laws and regulations concerning work near buried gas pipes.

**CAUTION** Before you start using the machine, check with your local public water supplier if there are buried pipes and drains on the site. If there are, obtain a map of their locations and follow the advice given by the water supplier.

You are strongly advised to make sure that the safety arrangements on site comply with the local laws and regulations concerning work near buried pipes and drains.

**CAUTION** If you cut through a fibre optic cable, Do not look into the end of it, your eyes could be permanently damaged.

An applicable worksite organisation is required in order to minimise hazards that are caused by restricted visibility. The worksite organisation is a collection of rules and procedures that coordinates the machines and people that work together in the same area. Examples of worksite organisation include:

- Restricted areas
- Controlled patterns of machine movement
- A system of communication.

You and/or your company could be legally liable for any damage you may cause to public utilities. It is your responsibility to make sure that you know the locations of any public utility cables or pipes on the worksite which could be damaged by your machine.



## 24 - Risk Assessment

### Introduction

It is the responsibility of the competent people that plan the work and operate the machine to make a judgement about the safe use of the machine, they must take into account the specific application and conditions of use at the time.

It is essential that a risk assessment of the work to be done is completed and that the operator obeys any safety precautions that the assessment identifies.

If you are unsure of the suitability of the machine for a specific task, contact your JCB dealer who will be pleased to advise you.

The following considerations are intended as suggestions of some of the factors to be taken into account when a risk assessment is made. Other factors may need to be considered.

A good risk assessment depends on the training and experience of the operator. Do not put your life or the lives of others at risk.

### Personnel

- Are all persons who will take part in the operation sufficiently trained, experienced and competent? Are they fit and sufficiently rested? A sick or tired operator is a dangerous operator.
- Is supervision needed? Is the supervisor sufficiently trained and experienced?
- As well as the machine operator, are any assistants or lookouts needed?

### The Machine

- Is it in good working order?
- Have any reported defects been corrected?
- Have the daily checks been carried out?
- Are the tyres still at the correct pressure and in good condition and is there sufficient fuel to complete the job (if applicable)?

### The Load

- How heavy is it? Is it within the capabilities of the machine?
- How bulky is it? The greater the surface area, the more affected it will be by wind speeds.
- Is it an awkward shape? How is the weight distributed? Uneven loads are more difficult to handle.
- Is there a possibility of the load shifting while being moved?

### Loading/Unloading Area

- Is it level? Any slope of more than 2.5% (1 in 40) must be carefully considered.
- Is more than one direction of approach to the load possible? Approaching across the slope must be avoided, if possible.
- Is the ground solid? Will it support the weight of the machine when loaded?
- How rough is the ground? Are there any sharp projections which could cause damage, particularly to the tyres?
- Are there any obstacles or hazards in the area, for example, debris, excavations, manhole covers, power lines?
- Is the space sufficient for safe manoeuvring?
- Are any other machines or persons likely to be in or to enter the area while operations are in progress?

### The Route to be Travelled

- How solid is the ground, will it provide sufficient traction and braking? Soft ground will affect the stability of the machine and this must be taken into account.
- How steep are any slopes, up/down/across? A cross slope is particularly hazardous, is it possible to detour to avoid them?

### Weather

- How windy is it? High wind will adversely affect the stability of a loaded machine, particularly if the load is bulky.
- Is it raining or is rain likely? The ground that was solid and smooth when dry will become uneven and slippery when wet, and it will not give the same conditions for traction, steering or braking.

## 27 - Maintenance Positions

Introduction ..... 01-12  
 Health and Safety ..... 01-13

### Introduction

Make the machine safe before you start a maintenance procedure. You can complete most of the maintenance procedures with the lift arm lowered. Unless a maintenance procedure instructs you differently, you must lower the lift arm.

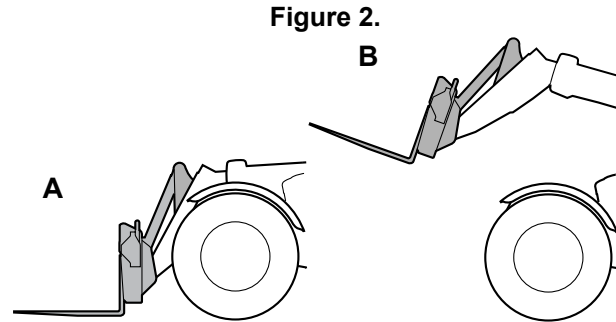

- A** Lift Arm Lowered
- B** Lift Arm Raised

### Lift Arm Lowered

1. Make sure that the machine is parked correctly in the straight-ahead position on solid, level ground.
2. Lower the lift and put the attachment flat on the ground.
3. Stop the engine and remove the ignition key.
4. Install the articulation lock. Refer to (PIL 06-27).
5. Isolate the battery to prevent the accidental operation of the engine. Refer to (PIL 33-03).
6. Put chocks on both sides of all the wheels before you get below the machine.

### Lift Arm Raised

1. Park the machine on solid, level ground.
2. Install the articulation lock. Refer to (PIL 06-27).
3. Support the lift arm. You must use a suitable support.
4. Stop the engine and remove the ignition key.
5. Disconnect the battery to prevent accidental operation of the engine. Refer to (PIL 33-03).
6. If necessary, put chocks against the two sides of the wheels before you get below the machine.

## Health and Safety

▲ **WARNING** Maintenance must be done only by suitably qualified and competent persons.

Before doing any maintenance make sure the machine is safe, it must be correctly parked on solid, level ground.

To prevent anyone starting the engine, remove the ignition key. Disconnect the battery when you are not using electrical power. If you do not take these precautions you could be killed or injured.

**WARNING** Make the machine safe before getting beneath it. Make sure that any attachments on the machine are correctly attached. Engage the park brake, remove the ignition key, disconnect the battery.



## 06 - About this Manual

Contents	Page No.
01-06-06 Using the Manual .....	01-15

## 06 - Using the Manual

### Introduction

Information in this manual conforms to a standard JCB service manual format. The format uses section headings taken from a PIL (Parts Identification

List). These headings are assigned numerical identification references.

**Table 1.**

Example	Section	Main Assembly / Heading	Component / Sub-heading
PIL reference	33	03	03
Heading	Electrical System	Battery	Isolator Switch

Information within each PIL reference is included under a set of standard headings such as Introduction, Health and Safety, Technical Data and Operation for example. Where additional relevant

information is contained within another PIL reference a cross reference is provided.

The main systems information is contained in the manual as follows.

**Table 2.**

System	PIL Reference	Heading
Hydraulic System	30-00-50	Schematic Circuit
Electrical System	33-03-03	Battery - Isolator Switch
	33-09-00	Power Distribution (including fuses and relays)
	33-00-50	Schematic Circuit
Electronic Diagnostic	33-57	Electronic Diagnostic (including Servicemaster)

### Machine Variants

Where information is different depending on machine variant, the applicable information sets are included within the same PIL reference. Headings are included to identify which information is for which variant. Make sure you use the correct information.

- Ensure that the machine electronic set-up is applicable. Use the applicable Servicemaster vehicle set-up tool. Refer to PIL 33-57-03.
- Use the applicable Servicemaster diagnostics tools. Refer to PIL 33-57-03.

### Diagnostics

Information in this manual can help you diagnose machine faults.

Before attempting to diagnose possible faults check the following.

- Ensure that the operator understands the machine controls, functions and use. Refer to the applicable Operator Manual.
- Check that the maintenance record complies with the applicable schedule for the operating environment. Refer to PIL 78-24.
- Check that the fuel and hydraulic oil in use complies with the standards specified. Refer to PIL 75-03 and 75-18.

### Torque Tightening

When you replace components, always tighten the applicable fixings to the correct torque value. Use the torque tightening values contained in the individual procedures (Remove and Install, Disassemble and Assemble etc.). If no torque values are specified, use the standard torque tightening values. Refer to Fasteners and Fixings, Screws, Bolts, Nuts, Technical Data (PIL 72-00). For the torque setting to be effective, do the following before you install the fixings.

- Make sure that all the applicable component assemblies are correct.
- Make sure that the applicable fixings are to the correct specification. If necessary discard the original fixings and replace them with new ones. The relevant procedures indicate when this is necessary.

- Make sure that the applicable fixings and threaded holes are free from contamination. This includes dirt, debris, old sealants and compounds, fluids and lubricants.



## 09 - Description

**Contents**

**Page No.**

01-09-12 Main Component Locations ..... 01-19



---

Notes:

---

---

---

---

---

---

---

---

---

---

---

---



## 12 - Main Component Locations

### Introduction

Figure 3.

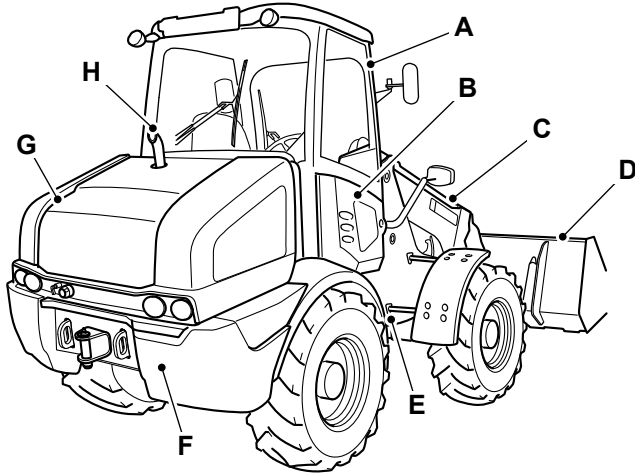

- A Cab
- B Door panel
- C Lift arm
- D Attachment (shovel)
- E Articulation lock
- F Counterweight
- G Engine cover
- H Exhaust stack

The illustration(s) show a typical machine model, your machine may look different to the model shown.



## 33 - Cleaning

**Contents**

**Page No.**

01-33-00 General .....	01-21
------------------------	-------

## 00 - General

Introduction .....	01-21
Preparation .....	01-22
Clean .....	01-23

## Introduction

**▲ WARNING** When using cleaning agents, solvents or other chemicals, you must adhere to the manufacturer's instructions and safety precautions.

**CAUTION** To avoid burning, wear personal protective equipment when handling hot components. To protect your eyes, wear goggles when using a brush to clean components.

**Notice:** Cleaning metal parts with incorrect solvents can cause corrosion. Use only recommended cleaning agents and solvents.

**Notice:** The efficiency of the rams will be affected if they are not kept free of solidified dirt. Clean dirt from around the rams regularly. When leaving or parking the machine, close all rams if possible to reduce the risk of weather corrosion.

**Notice:** Never use water or steam to clean inside the operator station. The use of water or steam could damage the machine electrics and render the machine inoperable. Remove dirt using a brush or damp cloth.

Clean the product with water and/or steam. Do not let mud, debris etc. to collect on the product.

Before you do any service procedures that require components to be removed:

- The cleaning must be done either in the area of components to be removed, or in the case of major work, or work on the fuel system, the whole engine and the surrounding product must be cleaned.
- When cleaning is complete, move the product away from the wash area or alternatively, remove the material washed from the product.

When you remove components, be aware of exposure to dirt and debris. Cover any open ports and remove the deposits before proceeding.

## Detergents

Do not use a full strength detergent. Always dilute the detergents as per the manufacturer's recommendations, or damage to the paint finish can occur.

Always obey the local regulations regarding the disposal of debris created from cleaning the product.

## Pressure Washing and Steam Cleaning

**▲ CAUTION** When using a steam cleaner, wear safety glasses or a face shield as well as protective clothing. Steam can cause personal injury.

**Notice:** The engine and other components could be damaged by high pressure washing systems. Special precautions must be taken if the machine is to be washed using a high pressure system.

Make sure that the alternator, starter motor and any other electrical components are shielded and not directly cleaned by the high pressure cleaning system. Do not aim the water jet directly at bearings, oil seals or the engine air induction system.

Use a low pressure water jet and brush to remove dried mud or dirt.

Use a pressure washer to remove soft dirt and oil.

The product must always be greased (if appropriate) after pressure washing or steam cleaning.

## Preparation

1. Make the machine safe. Stop the engine and let it cool for at least one hour. Do not try to clean any part of the engine while it is running.
2. Make sure that all of the electrical connectors are correctly coupled.
3. If the connectors are open, attach the correct caps or seal with waterproof tape.

## Clean

**▲ WARNING** Airborne particles of light combustible material such as straw, grass, wood shavings, etc. must not be allowed to accumulate within the engine compartment or in the propshaft guards (when installed). Examine these areas frequently and clean at the beginning of each work shift or more often if required. Before opening the engine cover, make sure that the top is clear of debris.

1. Make the machine safe with the lift arm lowered. Refer to (PIL 01-03).
2. Make sure that the engine is safe to work on. If the engine has been running, let it cool before you start the service work.
  - 2.1. Do not try to clean any part of the running engine.
3. Make sure that all the electrical connectors are connected correctly. If the connectors are open, install the correct caps or seal with waterproof tape.
4. Put covers on the electrical/electronic components.
5. Make sure that the underneath of the machine is clean.
6. Do not let mud build-up on the engine or transmission system. If necessary, steam clean.
7. Check the condition of the cooling pack. Clean the cooling pack as required. Refer to (PIL 21-00).



---

Notes:

---

---

---

---

---

---

---

---

---

---

---

---



---

## 03 - Attachments, Couplings and Load Handling

Contents	Page No.
03-00 Attachments	
03-00-00 General .....	03-3
03-09 Lift Arm Quickhitch	
03-09-00 General .....	03-7
03-09-06 Hydraulic Quickhitch .....	03-8
03-09-30 Carriage .....	03-11
03-30 Shovel	
03-30-00 General .....	03-13
03-33 Fork	
03-33-00 General .....	03-17
03-33-03 Carriage .....	03-20







## **00 - Attachments**

**Contents**

**Page No.**

03-00-00 General ..... 03-3



---

Notes:

---

---

---

---

---

---

---

---

---

---

---

---



## 00 - General

Introduction ..... 03-3  
Health and Safety ..... 03-4

## Introduction

A wide range of optional attachments are available to increase the versatility of your machine. Only JCB approved attachments are recommended for use with your machine. Consult your JCB Distributor for the full list of approved attachments available.

Some attachments are supplied complete with instructions on safety, installing and removing, operation and maintenance. Read and fully understand the information before fitting, using and servicing the attachment. If there is anything you do not understand, ask your JCB Distributor.

Before using any attachment, read Working With The Machine in the Operator Manual and consider how the attachment is going to affect operational safety. With the attachment installed, there may be changes in the machine's centre of gravity or overall dimensions. This could have an effect on, for example, machine stability, the gradients on which it is safe to operate or the safe distance from power lines.

Practice using attachments off the job before working with them for the first time.

JCB attachments are designed and manufactured specifically to suit the machine's hydraulic system, mounting arrangements and safe load requirements. Attachments which are not designed for use with this machine may cause damage and create safety hazards for which JCB cannot be held responsible. In addition the machine's warranty and any other legislative compliance may be affected by the use of non JCB approved attachments.

If your machine needs the hydraulic system adapting to facilitate the use of auxiliary attachments, you must consult your distributor. Only suitably qualified personnel must reroute hydraulic hoses.

All optional attachments will have limits on their operation. i.e. lifting capacity, speeds, hydraulic flow rates, etc. Always check in the literature supplied with the attachment or in the Specification section of this manual. Some specification limits may also be displayed on the attachments Data/Rating Plate.

**Important:** Do not operate or work with attachments until the machine hydraulic oil has reached its normal working temperature.

## Health and Safety

### Attachments

Use only the JCB approved attachments that are specified for your machine. Operating with non-specified attachments can overload the machine, causing possible damage and machine instability which could result in injury to yourself or others.

The use of non-approved attachments could invalidate your warranty.

### Attachments

If you have an attachment which is not covered in the Operator's Manual do not install it, use it or remove it until you have obtained, read and understood the pertinent information. Install attachments only on the machines for which they were designed.

**WARNING!** *Load and unload on firm, level ground. Always be alert for possible hazards. Take special care when turning or reversing.*

**DANGER!** *Before lowering the attachments to the ground, make sure that the machine and the area around it are clear of other people. Anyone on or close to the machine could fall and be crushed by the attachments, or get caught in the linkages.*

**DANGER!** *Using the forks alone as a working platform is hazardous; you can fall off and be killed or injured. Never use the forks as a working platform.*



## **09 - Lift Arm Quickhitch**

<b>Contents</b>	<b>Page No.</b>
03-09-00 General .....	03-7
03-09-06 Hydraulic Quickhitch .....	03-8
03-09-30 Carriage .....	03-11





### 00 - General

#### Introduction

Quickhitches are used on machines to allow the rapid change of buckets, shovels and other attachments on the machine.

Quickhitches do not normally have a specific function themselves in that they do not carry out handling or digging operations, but when installed on a machine they become a part of the overall machine system. They are usually mounted on the machine by means of pins that would otherwise be the mountings for the shovel or attachment.

## 06 - Hydraulic Quickhitch

## Lubricate

Lubricate .....	03-8
Remove and Install .....	03-9

There are two greasing points for the lubrication of the quickhitch. Refer to Figure 4.

Figure 4.

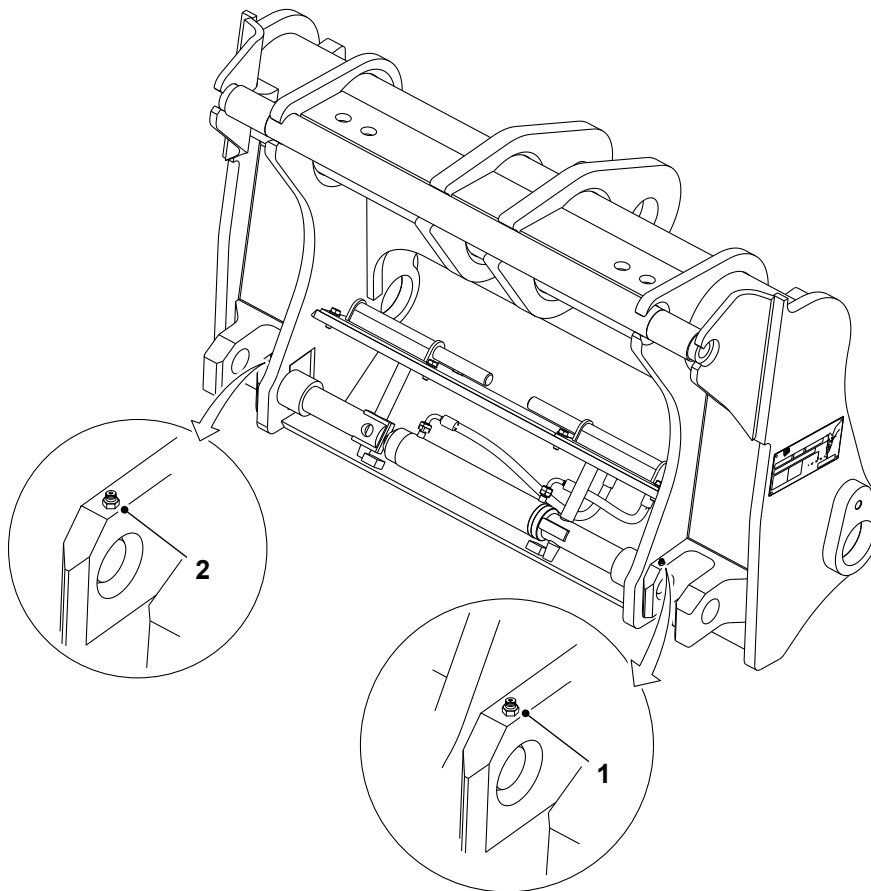



### Remove and Install

#### Hydraulic Pressure

Hydraulic fluid at system pressure can injure you. Before connecting or removing any hydraulic hose, residual hydraulic pressure trapped in the service hose line must be vented. Make sure the hose service line has been vented before connecting or removing hoses. Make sure the engine cannot be started while the hoses are open.

#### Remove

1. Make the machine safe with the lift arm lowered. Refer to (PIL 01-03).
2. Install the articulation strut. Refer to (PIL 06-27).
3. Isolate the battery from the electrical circuit. Refer to (PIL 33-03).
4. Use suitable lifting equipment to support the quickhitch.
5. Disconnect the hydraulic hoses.

**Figure 5.**

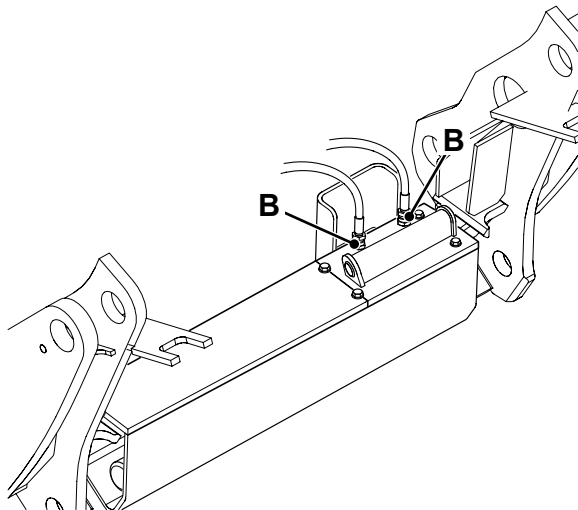

**B** Hydraulic hoses (x2)

6. Remove the bolts and the pivot pins from both sides of the quickhitch.

**Figure 6.**

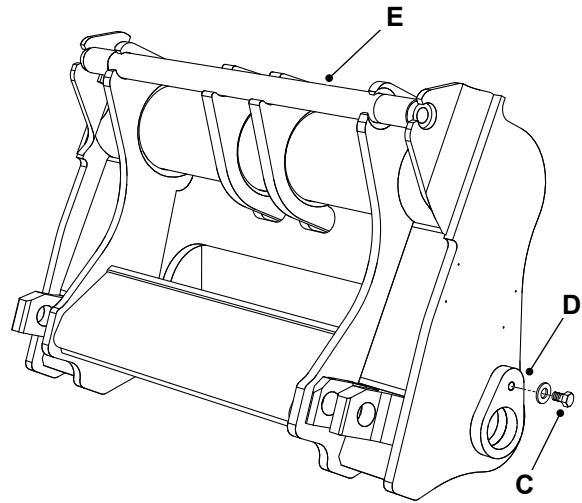

**C** Bolts (x2)  
**D** Pivot pins (x2)  
**E** Quickhitch

7. Remove the quickhitch from the lift arms.
8. Check the condition of the bushes and seals.

**Figure 7.**

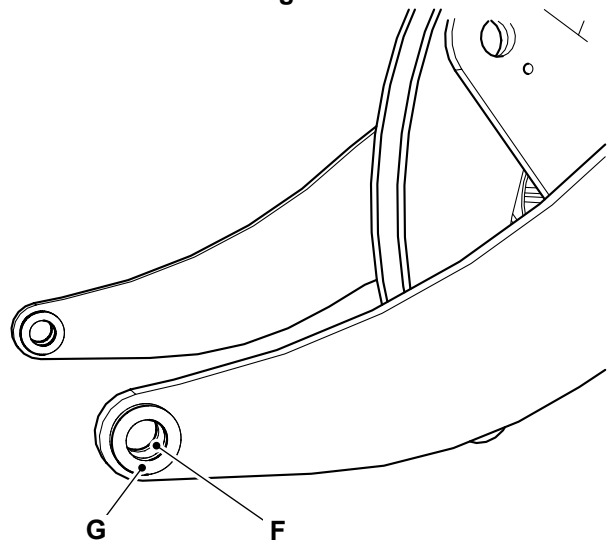

**F** Bushes  
**G** Seals

9. Replace the bushes and seals if they are damaged or worn.
10. Use a suitable press or puller to remove the bush.

#### Install

The installation procedure is the opposite of the removal procedure. Additionally do the following steps.

1. Use a press to install the new bush and then replace the seal.

**Figure 8.**

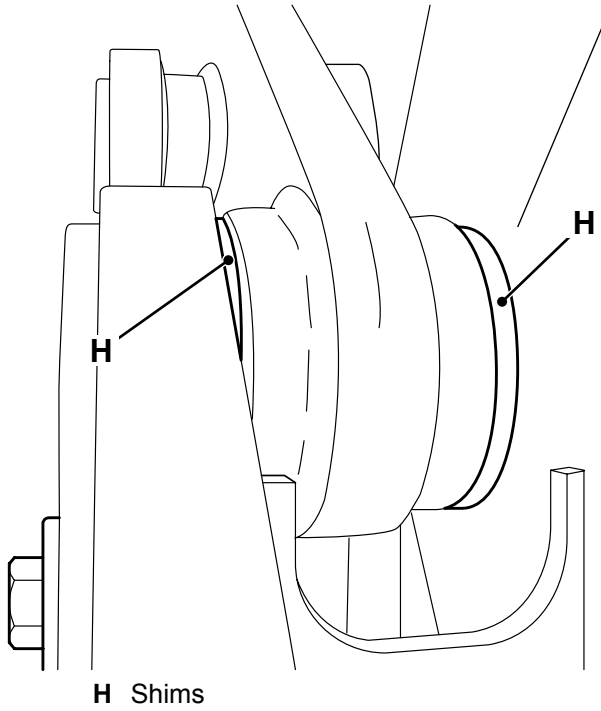

2. Install the spacer shims as necessary.

## 30 - Carriage

### Lubricate

1. Remove any attachments before you grease the locking pins.
2. Use the relevant grease gun to grease the points shown. Refer to (PIL 75-06).

**Figure 9.**

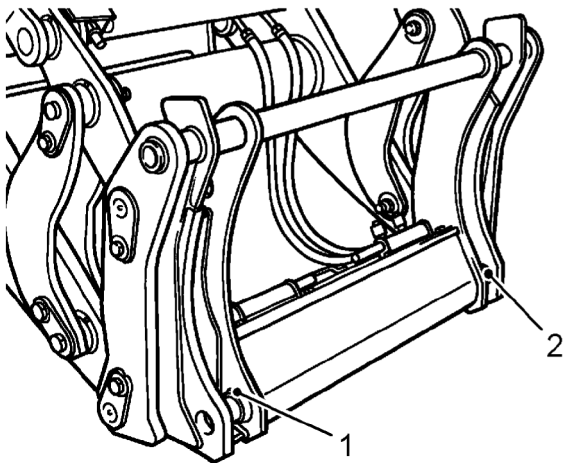

- 1 Grease point 1
- 2 Grease point 2



## 30 - Shovel

**Contents**

**Page No.**

03-30-00 General .....	03-13
------------------------	-------



**00 - General**

Introduction ..... 03-13  
Health and Safety ..... 03-14

**Introduction**

A shovel can be installed on many different types of earthmoving machines. The shovel can be directly mounted on to a lift arm assembly or mounted to the lift arm via a quickhitch assembly.

There are a vast amount and size of shovels used for numerous applications.

A shovel can be used to scoop up loose material from the ground, such as dirt, sand or gravel, and move it from one place to another without pushing the material across the ground. It is commonly used to move stockpiled material from ground level and deposited into a dump truck or into an open trench excavation.



### Health and Safety

- ▲ **CAUTION** This component is heavy. It must only be removed or handled using a suitable lifting method and device.



## 33 - Fork

Contents	Page No.
03-33-00 General .....	03-17
03-33-03 Carriage .....	03-20



---

Notes:

---

---

---

---

---

---

---

---

---

---

---

---





**00 - General**

Introduction ..... 03-17  
Health and Safety ..... 03-18  
Adjust ..... 03-18

**Introduction**

Forks can be installed on many different types of agricultural or construction machines. Forks can be directly mounted on to a lift arm or carriage or mounted to a lift arm via a quickhitch assembly. There are a vast amount and size of forks used for numerous applications.

Forks can be used to lift, raise and carry heavy things and stack them where required.

## Health and Safety

**▲ DANGER** Using the forks alone as a working platform is hazardous; you can fall off and be killed or injured. Never use the forks as a working platform.

**WARNING** Loads can fall off incorrectly spaced forks. Always space the forks correctly for the load. Make sure the forks are completely under the load before lifting.

**WARNING** If the fork/locking pin is not fully engaged, the fork could become unintentionally disengaged.

**WARNING** Do not try to correct the alignment of the fork tips by bending the forks or adding shims. Never repair damaged forks by heating or welding. Forks are made of special steel using special procedures. Always replace the damaged forks.

**WARNING** Overloaded scaffolding can collapse. Never load scaffolding beyond the regulation capacity.

**WARNING** The forks project in front of the machine. Make sure there is enough clearance for the forks when making turns.

**CAUTION** A load lifted on one fork can slip off. Never lift a load with one fork.

**CAUTION** Never unload the forks by stopping the machine suddenly. Follow the procedures in the Operator Manual for unloading.

**CAUTION** The forks are heavy. Make sure suitable lifting equipment is used to support and transport them.

**CAUTION** Do not exceed the total rated load capacity of the forks being used. Forks can break resulting in a loss of load and possible injury.

**CAUTION** Loads stacked on uneven ground can topple. Never stack loads on uneven ground.

## Adjust

**▲ WARNING** Loads can fall off incorrectly spaced forks. Always space the forks correctly for the load. Make sure the forks are completely under the load before lifting.

**CAUTION** To prevent unintentional detachment of forks during travel or transportation, the forks must not overlap the lower removal notch or be secured in the central two positions on top of the carriage.

**CAUTION** The forks are heavy. Make sure suitable lifting equipment is used to support and transport them.

**WARNING** If the fork/locking pin is not fully engaged, the fork could become unintentionally disengaged.

## Repositioning the Forks

### Industrial Carriage Fork Adjustment

1. Park the machine on solid level ground. Apply the park brake (if fitted).
2. Lower the forks as required to enable the use of suitable lifting equipment to move the forks.
3. Stop the engine. Remove the ignition key.
4. Release the locking pins and slide the forks to the desired position using suitable lifting equipment. Your machine will have either 'twist and pull' or 'pull' type fork locking pins. Forks must not overlap the lower removal notch or be secured in the central two positions on top of the carriage, see shaded 'no fork' zone.

This as a preview PDF file from [best-manuals.com](http://best-manuals.com)



Download full PDF manual at [best-manuals.com](http://best-manuals.com)