



# Bobcat®

---

## Service Manual

### TL358

# Telescopic Handler

---

(TL358DCW) S/N B3G511001 & Above  
(TL358D) S/N B3GH11001 & Above  
(TL358HCW) S/N B3GJ11001 & Above  
(TL358H) S/N B3GK11001 & Above

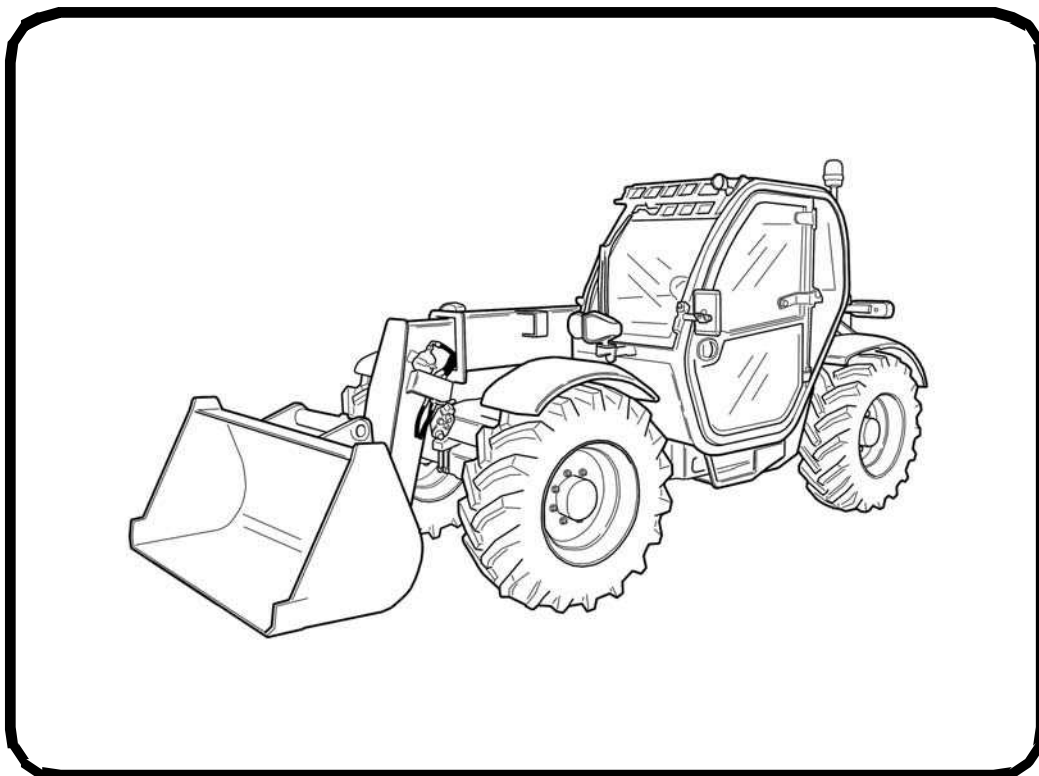



# MAINTENANCE SAFETY



## WARNING

Instructions are necessary before operating or servicing machine. Read and understand the Operation & Maintenance Manual, Operator's Handbook and signs (decals) on machine. Follow warnings and instructions in the manuals when making repairs, adjustments or servicing. Check for correct function after adjustments, repairs or service. Untrained operators and failure to follow instructions can cause injury or death.

W-2003-0807

### CORRECT

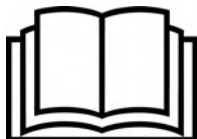

P-90216

- ⚠ Never service the Bobcat telescopic handler without instructions.



**Safety Alert Symbol:** This symbol with a warning statement, means: "Warning, be alert! Your safety is involved!" Carefully read the message that follows.

### CORRECT



NA5428

- ⚠ Cleaning and maintenance are required daily.

### WRONG

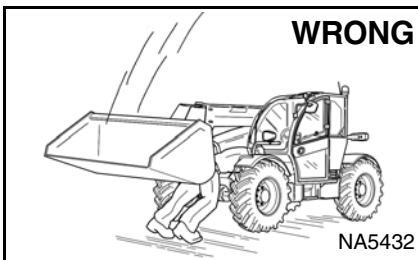

NA5432

- ⚠ Disconnecting or loosening any hydraulic tubeline, hose, fitting, component or a part failure can cause boom to drop. Do not go under boom when raised unless supported by an approved boom stop. Replace if damaged.

### WRONG

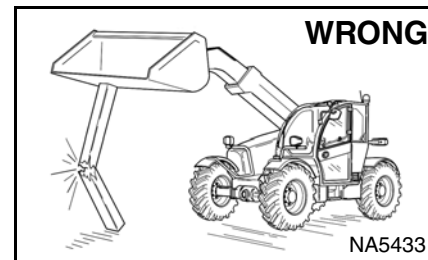

NA5433

- ⚠ Never work on telescopic handler with boom up unless boom is held by an approved boom stop. Replace if damaged.
- ⚠ Never modify equipment or add attachments not approved by Bobcat Company.

### WRONG

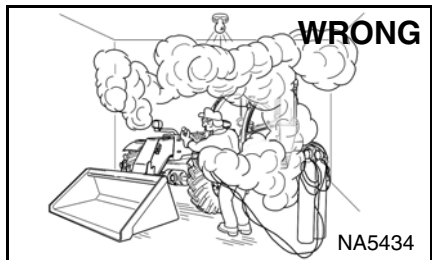

NA5434

- ⚠ Have good ventilation when welding or grinding painted parts.
- ⚠ Wear dust mask when grinding painted parts. Toxic dust and gas can be produced.
- ⚠ Avoid exhaust fume leaks which can kill without warning. Exhaust system must be tightly sealed.

### WRONG

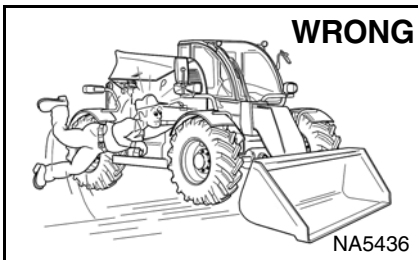

NA5436

- ⚠ Keep body, jewelry and clothing away from moving parts, electrical contact, hot parts and exhaust.
- ⚠ Wear eye protection to guard from battery acid, compressed springs, fluids under pressure and flying debris when engines are running or tools are used. Use eye protection approved for type of welding.

### WRONG



B-6589

- ⚠ Lead-acid batteries produce flammable and explosive gases.
- ⚠ Keep arcs, sparks, flames and lighted tobacco away from batteries.
- ⚠ Batteries contain acid which burns eyes or skin on contact. Wear protective clothing. If acid contacts body, flush well with water. For eye contact flush well and get immediate medical attention.

Maintenance procedures which are given in the Operation & Maintenance Manual can be performed by the owner/operator without any specific technical training. Maintenance procedures which are **not** in the Operation & Maintenance Manual must be performed **ONLY BY QUALIFIED BOBCAT SERVICE PERSONNEL**. Always use genuine Bobcat replacement parts.



**Bobcat®**

## CONTENTS

CONTENTS .....	1-03
FOREWORD .....	1-05
SAFETY AND MAINTENANCE .....	10-01
HYDRAULIC SYSTEM .....	20-01
HYDROSTATIC SYSTEM .....	30-01
DRIVE SYSTEM .....	40-01
MAINFRAME .....	50-01
ELECTRICAL SYSTEM AND ANALYSIS .....	60-01
ENGINE SERVICE .....	70-01
HEATING, VENTILATION, AIR CONDITIONING (HVAC) .....	80-01
SPECIFICATIONS .....	SPEC-01
ALPHABETICAL INDEX .....	INDEX-01



**Bobcat®**

# FOREWORD

FOREWORD .....	1-7
SAFETY INSTRUCTIONS .....	1-9
Safe Operation Is The Operator's Responsibility .....	1-9
Safe Operation Needs A Qualified Operator .....	1-9
Avoid Silica Dust .....	1-10
Dismantling And Disposal .....	1-10
FIRE PREVENTION .....	1-11
Maintenance .....	1-11
Operation .....	1-11
Electrical .....	1-11
Hydraulic System .....	1-11
Fueling .....	1-11
Starting .....	1-11
Welding And Grinding .....	1-12
Fire Extinguishers .....	1-12
SERIAL NUMBER LOCATION .....	1-13
Telescopic Handler Serial Number .....	1-13
Engine Serial Number .....	1-13
Diesel Oxidation Catalytic Converter Serial Number .....	1-14
Other Serial Numbers .....	1-14
DELIVERY REPORT .....	1-14
BOBCAT TELESCOPIC HANDLER IDENTIFICATION .....	1-15



**Bobcat®**



# FOREWORD

This manual is for the Bobcat telescopic handler mechanic. It provides necessary servicing and adjustment procedures for the Bobcat telescopic handler and its component parts and systems. Refer to the Operation & Maintenance Manual for operating instructions, starting procedure, daily checks, etc.

A general inspection of the following items must be made after the telescopic handler has had service or repair:

1. Check that ROPS/FOPS (Including right side window) is in good condition and is not modified.

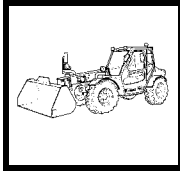

2. Check that ROPS mounting hardware is tightened and is Bobcat approved.

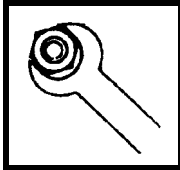

3. The seat belt must be correctly installed, functional and in good condition.

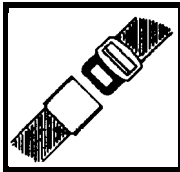

4. Check boom support device, replace if damaged.

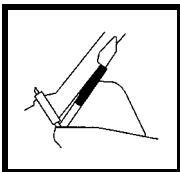

5. Machine signs must be legible and in the correct location.



6. Check tires for wear and pressure. Use only approved tires.

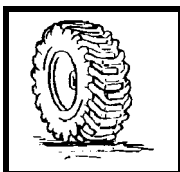

7. Check for correct function of the work lights.



8. The parking brake must function correctly.



9. Enclosure door latches must open and close freely.

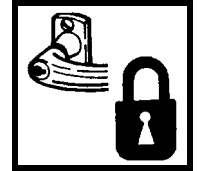

10. Attachment locking pins must function correctly and be in good condition.

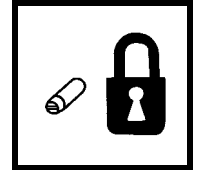

11. Safety treads must be in good condition.

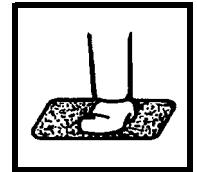

12. Check for correct function of indicator lamps and gauges.

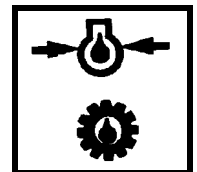

13. Check hydraulic fluid level, engine oil level and fuel supply.

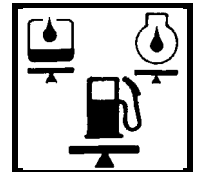

14. Inspect for fuel, oil or hydraulic fluid leaks.

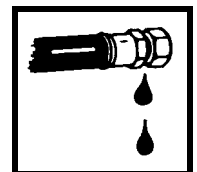

15. Lubricate the telescopic handler.

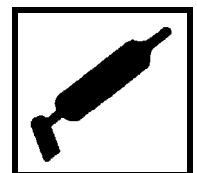

16. Check the condition of the battery and cables.

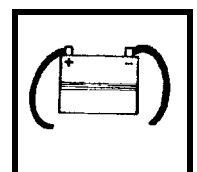

FW TLS EMEA-0411 SM

17. Inspect the air cleaner for damage or leaks. Check the condition of the element.

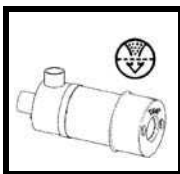

18. Check the electrical charging system.

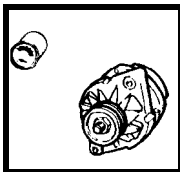

19. Inspect for loose or broken parts or connections.

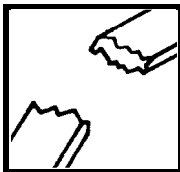

20. Operate the telescopic handler and check all functions.

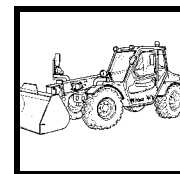

21. Check for any field modification not completed.



22. Recommend to the owner that all necessary corrections be made before the machine is returned to service.

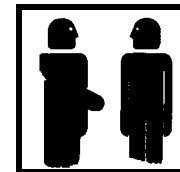

## SAFETY INSTRUCTIONS

### Safe Operation Is The Operator's Responsibility



Operator must have instructions before operating the machine. Untrained operators can cause injury or death.

W-2001-0502



This notice identifies procedures which must be followed to avoid damage to the machine.

I-2019-0284



The signal word DANGER on the machine and in the manuals indicates a hazardous situation which, if not avoided, will result in death or serious injury.

D-1002-1107



The signal word WARNING on the machine and in the manuals indicates a potentially hazardous situation which, if not avoided, could result in death or serious injury.

W-2044-1107

The telescopic handler and attachment must be in good operating condition before use.

Check all of the items on the Bobcat Service Schedule Decal under the 8-10 hour column or as shown in the Operation & Maintenance Manual.

### Safe Operation Needs A Qualified Operator

For an operator to be qualified, he or she must not use drugs or alcoholic drinks which impair alertness or coordination while working. An operator who is taking prescription drugs must get medical advice to determine if he or she can safely operate a machine.

*A Qualified Operator Must Do The Following:*

*Understand the Written Instructions, Rules and Regulations*

- The written instructions from Bobcat Company include the Delivery Report, Operation & Maintenance Manual, Operator's Handbook and machine signs (decals).
- Check the rules and regulations at your location. The rules may include an employer's work safety requirements. For driving on public roads, the machine must be equipped as stipulated by the local regulations authorising operation on public roads in your specific country. Regulations may identify a hazard such as a utility line.
- For operating the machine, some countries require an operator license. Check the regulations at your location.

*Have Training with Actual Operation*

- Operator training must consist of a demonstration and verbal instruction. This training is given by your Bobcat dealer before the product is delivered.
- The new operator must start in an area without bystanders or structures and use all the controls until he or she can operate the machine and attachment safely under all conditions of the work area. Always fasten seat belt before operating.

*Know the Work Conditions*

- Know the weight of the materials being handled. Avoid exceeding the Rated Load Capacity of the machine (as indicated on the Load Capacity Charts). Material which is very dense will be heavier than the same volume of less dense material. Reduce the size of load if handling dense material.
- The operator must know any prohibited uses or work areas, for example, he or she needs to know about excessive slopes.
- Know the location of any underground lines.
- Wear tight fitting clothing. Always wear safety glasses when doing maintenance or service. Safety glasses, respiratory equipment, hearing protection or Front Window Guard are required for some work. See your Bobcat dealer about Bobcat Safety Equipment.

SI TH EMEA-0913 SM

## SAFETY INSTRUCTIONS (CONT'D)

### Safe Operation Needs A Qualified Operator (Cont'd)

Where overhead power lines are present in the operating area, ensure sufficient clearance between the nearest of these lines and any part of the machine.

VOLTAGE	MINIMUM DISTANCE
up to 50 kV	3 m
beyond 50 kV	5 m

The operator must survey his / her field of vision when operating the telescopic handler. Adjust mirrors to obtain the best visibility. Clean mirrors every day and more often when necessary. Immediately replace any broken or damaged mirrors. If a suspended load or the resulting boom geometry blocks the vision of the operator alternative carrying means must be considered.

The operator must know the wind speed. Do not use the telescopic handler with wind speeds over 12,5 m/s.

### Avoid Silica Dust



Cutting or drilling concrete containing sand or rock containing quartz may result in exposure to silica dust. Use a respirator, water spray or other means to control dust.

## Dismantling And Disposal

On the completion of its useful life, the machine and its parts shall be disposed of in an environmental friendly manner. Please contact your local dealer. Parts of the machine can be remanufactured like the engine depending on its age and condition, or recycled like metals, plastics, rubbers and glasses. Respect the environment and dispose of waste properly. Worn or damaged parts shall not be left in the environment. Oils, brake fluid, cooling refrigerants, batteries and cells shall be disposed of in a proper manner through your local dealer or recycling center.

## FIRE PREVENTION



### Maintenance

The machine and some attachments have components that are at high temperatures under normal operating conditions. The primary source of high temperatures is the engine and exhaust system. The electrical system, if damaged or incorrectly maintained, can be a source of arcs or sparks.

Flammable debris (leaves, straw, etc.) must be removed regularly. If flammable debris is allowed to accumulate, it can cause a fire hazard. Clean often to avoid this accumulation. Flammable debris in the engine compartment is a potential fire hazard.

The operator's area, engine compartment and engine cooling system must be inspected every day and cleaned if necessary to prevent fire hazards and overheating.

All fuels, most lubricants and some coolants mixtures are flammable. Flammable fluids that are leaking or spilled onto hot surfaces or onto electrical components can cause a fire.

### Operation

Do not use the machine where exhaust, arcs, sparks or hot components can contact flammable material, explosive dust or gases.

### Electrical



Check all electrical wiring and connections for damage. Keep the battery terminals clean and tight. Repair or replace any damaged part or wires that are loose or frayed.

Battery gas can explode and cause serious injury. Use the procedure in the Operation & Maintenance Manual for connecting the battery and for jump starting. Do not jump start or charge a frozen or damaged battery. Keep any open flames or sparks away from batteries. Do not smoke in battery charging area.

## Hydraulic System

Check hydraulic tubes, hoses and fittings for damage and leakage. Never use open flame or bare skin to check for leaks. Hydraulic tubes and hoses must be properly routed and have adequate support and secure clamps. Tighten or replace any parts that show leakage.

Always clean fluid spills. Do not use petrol or diesel fuel for cleaning parts. Use commercial non-flammable solvents.

### Fueling



Stop the engine and let it cool before adding fuel. No smoking! Do not refuel a machine near open flames or sparks. Fill the fuel tank outdoors.

### Starting

Do not use ether or starting fluids on any engine that has glow plugs. These starting aids can cause explosion and injure you or bystanders.

Use the procedure in the Operation & Maintenance Manual for connecting the battery and for jump starting.

## **FIRE PREVENTION (CONT'D)**

### **Welding And Grinding**

Always clean the machine and attachment, disconnect the battery, and disconnect the wiring from the Bobcat controllers before welding. Cover rubber hoses, battery and all other flammable parts. Keep a fire extinguisher near the machine when welding.

Have good ventilation when grinding or welding painted parts. Wear dust mask when grinding painted parts. Toxic dust or gas can be produced.

Dust generated from repairing non-metallic parts such as hoods, fenders or covers can be flammable or explosive. Repair such components in a well ventilated area away from open flames or sparks.

### **Fire Extinguishers**

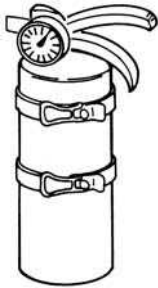

Know where fire extinguishers and first aid kits are located and how to use them. Inspect the fire extinguisher and service the fire extinguisher regularly. Obey the recommendations on the instructions plate.

## SERIAL NUMBER LOCATION

Always use the serial number of the telescopic handler when requesting service information or when ordering parts.

If any serial number plate is damaged, contact your Bobcat dealer.

### Telescopic Handler Serial Number

Figure 1

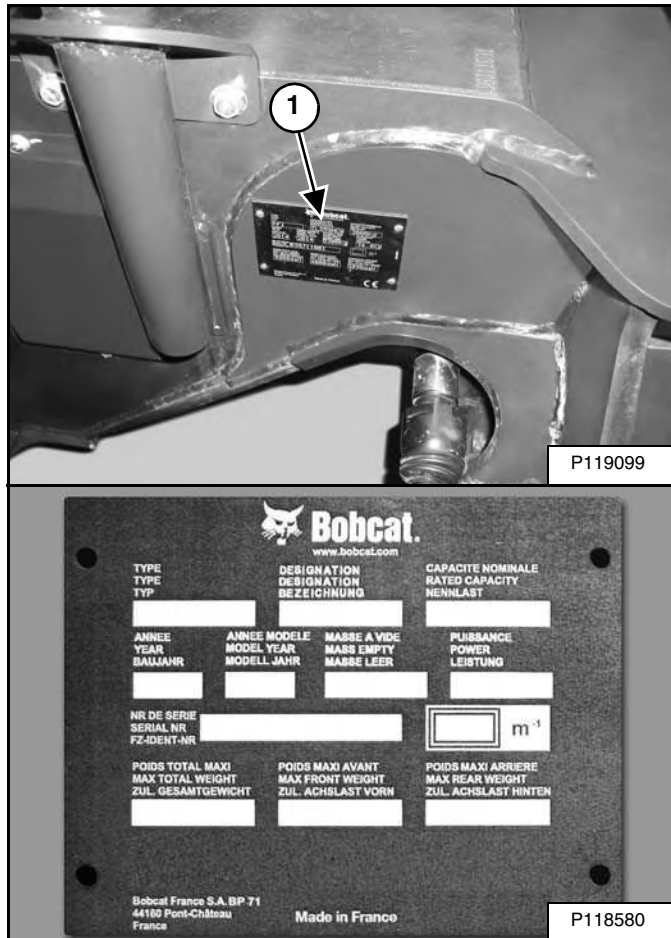

The telescopic handler serial number plate (Item 1) is located on the right side of the chassis in front [Figure 1].

Explanation of telescopic handler serial number:

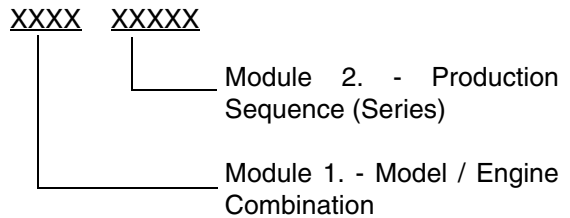

1. The four digit Model / Engine Combination Module number identifies the model number and engine combination.

2. The five digit Production Sequence Number identifies the order which the telescopic handler is produced.

### Engine Serial Number

Figure 2

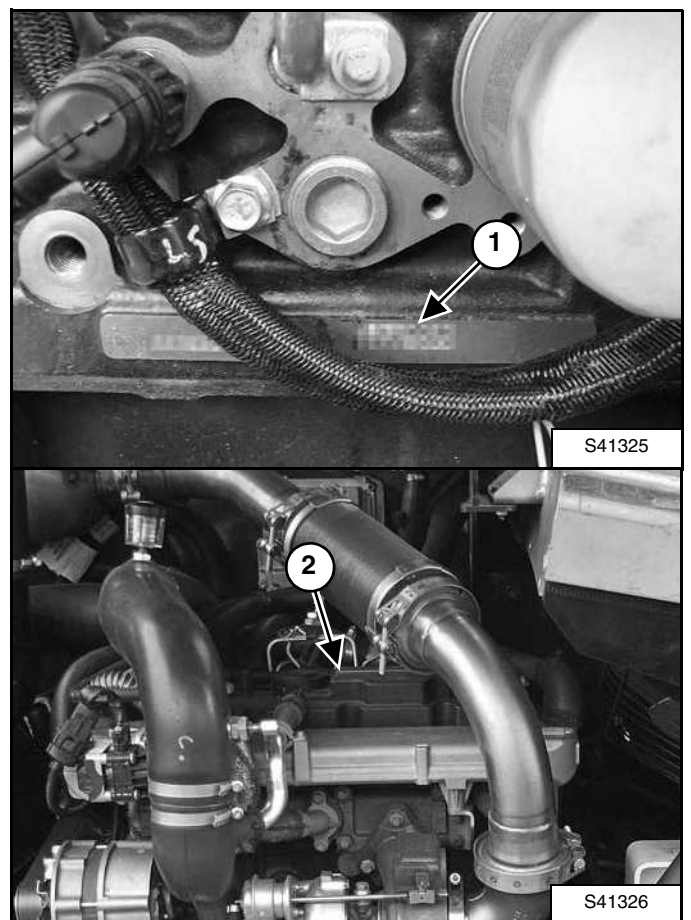

The engine serial number can be found on the engine cylinder block (Item 1) and on the engine rating plate (Item 2) [Figure 2] on top of the cylinder head in front of you when opening the engine cover. Always use the full number (type + number) when ordering replacement parts.

## SERIAL NUMBER LOCATION (CONT'D)

### Engine Serial Number (Cont'd)

Explanation of engine rating plate:

Figure 3

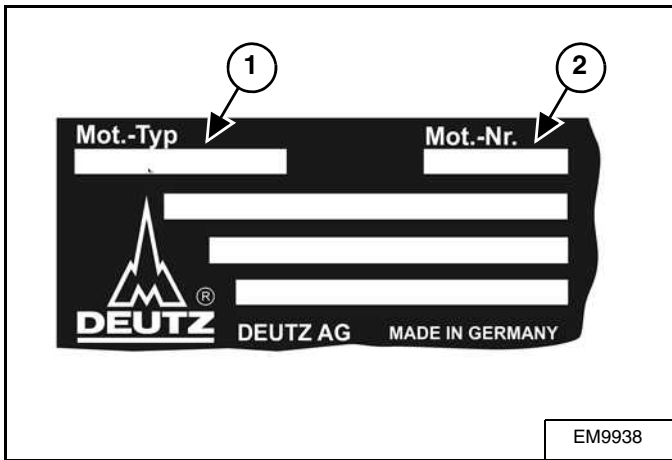

1. Identifies the engine type.
2. Identifies the engine number.

### Diesel Oxidation Catalytic Converter Serial Number

Figure 4

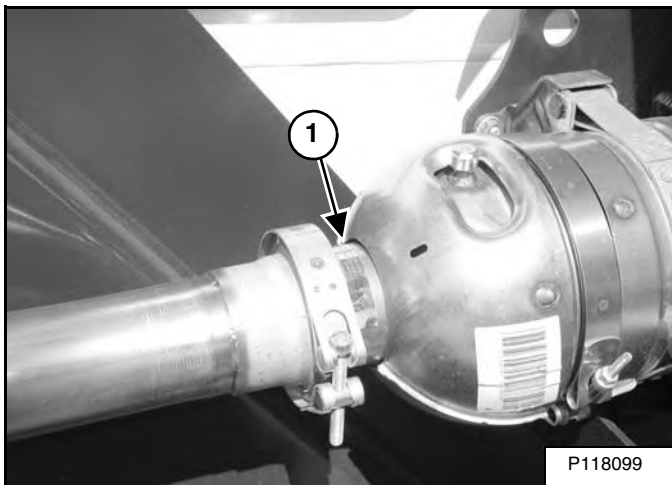

The diesel oxidation catalytic converter serial number can be found on the exhaust muffler (Item 1) [Figure 4]. Always use the full number when ordering replacement parts.

### Other Serial Numbers

Other components can also have serial numbers and an identification plate. Always use these serial numbers when ordering parts.

## DELIVERY REPORT

Figure 5

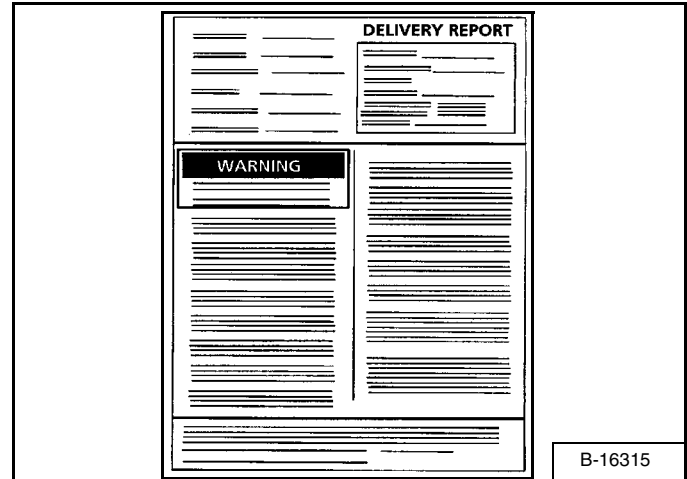

The delivery report [Figure 5] contains a list of items that must be explained or shown to the owner or operator by the dealer when the Bobcat telescopic handler is delivered.

The delivery report must be reviewed and signed by the owner or operator and the dealer.



## BOBCAT TELESCOPIC HANDLER IDENTIFICATION

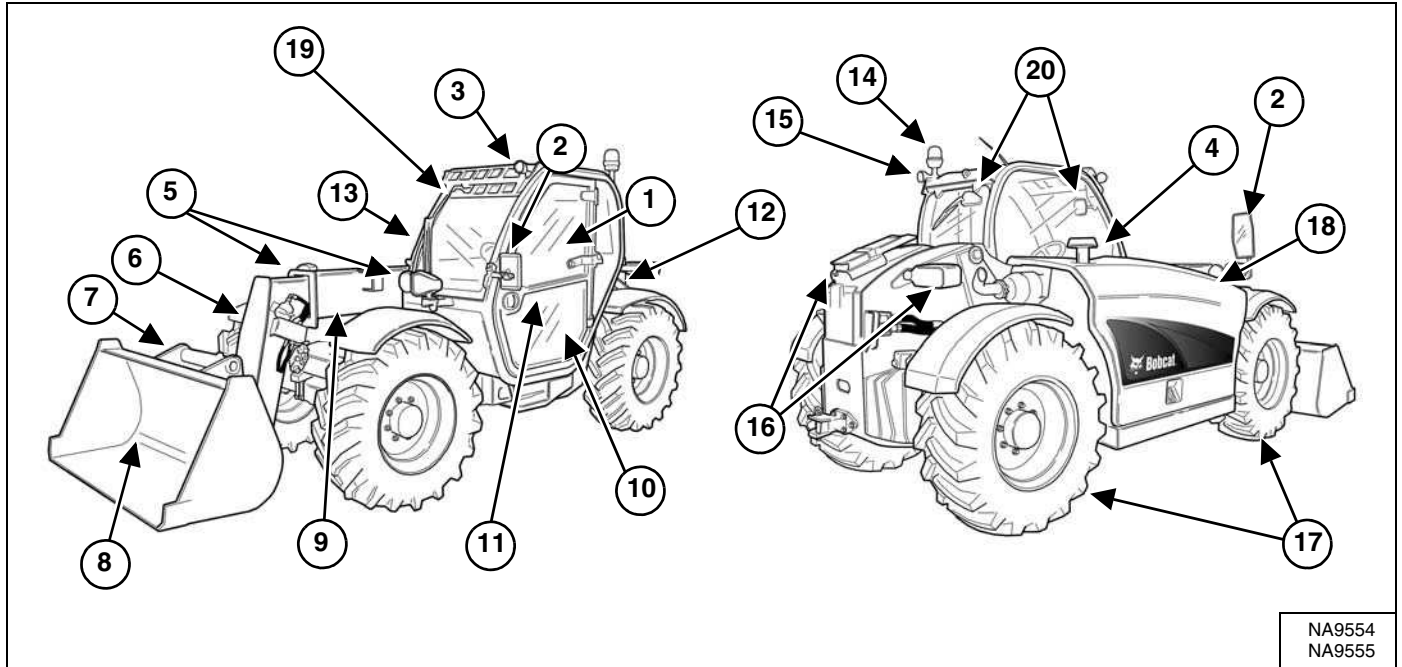

NA9554  
NA9555

ITEM	DESCRIPTION	ITEM	DESCRIPTION
1	Operation & Maintenance Manual and Operator's Handbook	11	Seat Belt
2	Mirrors	12	Boom Stop <b>[A]</b>
3	Work Lights	13	Operator Cab (ROPS and FOPS) <b>[C]</b>
4	Load Capacity Charts	14	Rotating Beacon <b>[A]</b>
5	Front Lights	15	Rear Work Light
6	Telescoping Boom	16	Tail Lights and Direction Signals
7	Boom Head	17	Tires <b>[D]</b>
8	Attachment Carrier <b>[B]</b>	18	Engine Cover
9	Boom	19	Sight Level Gauge
10	Parking Brake	20	Rear / Front Interior Mirror

**[A]** Optional or Field Accessory. (Not Standard Equipment).

**[B]** Attachments - Several different attachments are available for the Bobcat telescopic handler.

**[C]** ROPS, FOPS - Roll Over Protective Structure, per ISO 3471, and Falling Object Protective Structure per ISO 3449, Level II.

**[D]** TIRES - Standard tires are shown. Several different tire styles and sizes are available for the Bobcat telescopic handler.



**Bobcat®**

## SAFETY AND MAINTENANCE

LIFTING AND BLOCKING THE TELESCOPIC HANDLER .....	10-10-1
Procedure .....	10-10-1
OPERATOR CAB .....	10-20-1
Description .....	10-20-1
Cab Door .....	10-20-1
Cab Door Window .....	10-20-2
Rear Cab Window .....	10-20-3
Cab Light .....	10-20-3
TRANSPORTING THE TELESCOPIC HANDLER ON A TRAILER .....	10-30-1
Loading And Unloading .....	10-30-1
Fastening .....	10-30-1
TOWING THE TELESCOPIC HANDLER .....	10-40-1
Procedure .....	10-40-1
SERVICE SCHEDULE .....	10-50-1
Maintenance Intervals .....	10-50-1
AIR CLEANER SERVICE .....	10-60-1
Replacing Filter Elements .....	10-60-1
ENGINE COOLING SYSTEM .....	10-70-1
Cleaning .....	10-70-1
Checking Level .....	10-70-1
Removing And Replacing The Coolant .....	10-70-2
FUEL SYSTEM .....	10-80-1
Fuel Specifications .....	10-80-1
Biodiesel Blend Fuel .....	10-80-1
Filling The Fuel Tank .....	10-80-2
Primary Fuel Filter (Pre-Filter) .....	10-80-2
Secondary Fuel Filter .....	10-80-4
Removing Air From The Fuel System .....	10-80-4
ENGINE LUBRICATION SYSTEM .....	10-90-1
Checking And Adding Engine Oil .....	10-90-1
Engine Oil Chart .....	10-90-1
Removing And Replacing Oil And Filter .....	10-90-2
HYDRAULIC / HYDROSTATIC SYSTEM .....	10-100-1
Checking And Adding Fluid .....	10-100-1
Hydraulic / Hydrostatic Fluid Chart .....	10-100-2
Removing And Replacing Hydraulic Fluid .....	10-100-2
Removing And Replacing Hydraulic / Hydrostatic Filters .....	10-100-3
Fill / Breather Cap .....	10-100-5

AXLES (FRONT AND REAR) .....	10-110-1
Checking And Adding Oil (Planetary Carrier) .....	10-110-1
Removing And Replacing Oil (Planetary Carrier) .....	10-110-1
Checking And Adding Oil (Rear Differential) .....	10-110-2
Removing And Replacing Oil (Rear Differential) .....	10-110-2
Checking And Adding Oil (Front Differential) .....	10-110-3
Removing And Replacing Oil (Front Differential) .....	10-110-3
Checking And Adding Oil (Reduction Box) .....	10-110-4
Removing And Replacing Oil (Reduction Box) .....	10-110-4
LUBRICATING THE TELESCOPIC HANDLER .....	10-120-1
Lubrication Locations .....	10-120-1
ATTACHMENT CARRIER .....	10-130-1
Inspection And Maintenance .....	10-130-1
TIRE MAINTENANCE .....	10-140-1
Wheel Nuts .....	10-140-1
Rotating .....	10-140-1
Wheel replacement .....	10-140-1
Mounting .....	10-140-2
Pressure .....	10-140-2
APPROVED BOOM STOP .....	10-150-1
Installing The Approved Boom Stop .....	10-150-1
Removing The Approved Boom Stop .....	10-150-1
ENGINE COVER .....	10-160-1
Opening And Closing .....	10-160-1
STOPPING THE ENGINE AND LEAVING THE TELESCOPIC HANDLER .....	10-170-1
Procedure .....	10-170-1
EMERGENCY EXIT .....	10-180-1
Rear Window .....	10-180-1
TELESCOPIC HANDLER STORAGE AND RETURN TO SERVICE .....	10-190-1
Storage .....	10-190-1
Return To Service .....	10-190-1
LIFTING THE TELESCOPIC HANDLER .....	10-200-1
Procedure .....	10-200-1
REMOTE START TOOL (SERVICE TOOL) KIT - MEL1563 .....	10-210-1
Remote Start Tool - MEL1563 .....	10-210-1
Service Tool Harness Control - MEL1565 .....	10-210-2
Service Tool Harness Communicator - MEL1566 .....	10-210-3

REMOTE START TOOL (SERVICE TOOL) KIT - 7217666 .....	10-220-1
Remote Start Tool (Service Tool) - 7022042 .....	10-220-1
Telescopic Handler Service Tool Harness - 6689747 .....	10-220-2
Computer Service Tool Harness - 6689746 .....	10-220-4
Remote Start Procedure .....	10-220-4



**Bobcat®**

## LIFTING AND BLOCKING THE TELESCOPIC HANDLER

### Procedure

Always park the machine on a flat, solid and level surface.

**! WARNING**

**MACHINE FALLING OR MOVING CAN CAUSE SERIOUS INJURY OR DEATH**

Put jackstands under the front and rear of the machine before running engine for service.

W-2718-0208

Figure 10-10-1

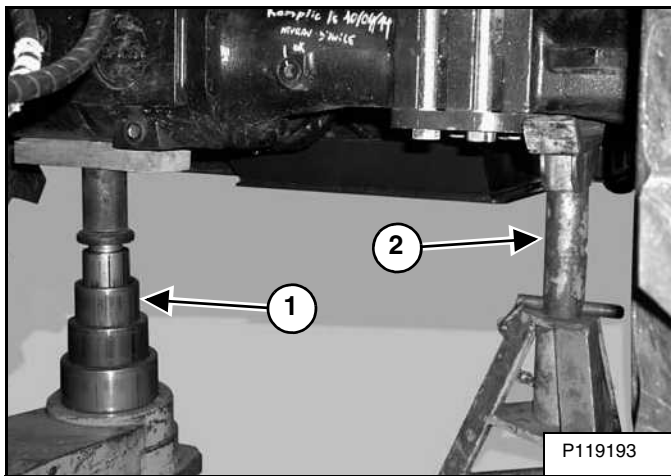

STOP the engine. Put the floor jack (Item 1) under the left side of the front axle. Lift the telescopic handler and install the first jackstand (Item 2) [Figure 10-10-1].

Figure 10-10-2

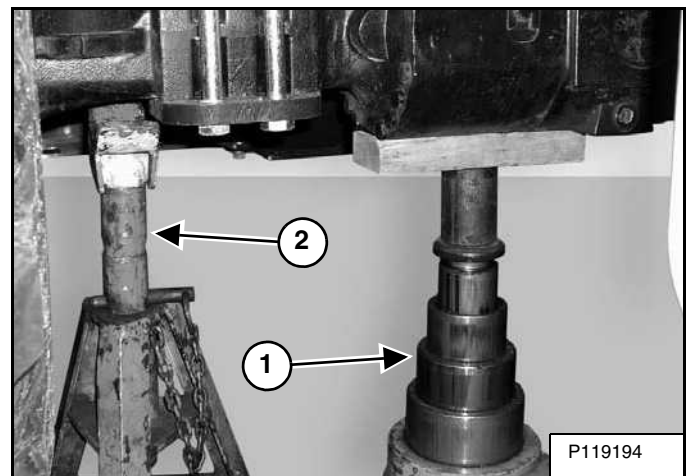

Put the floor jack (Item 1) under the right side of the front axle. Lift the telescopic handler and install the second jackstand (Item 2) [Figure 10-10-2].

Figure 10-10-3

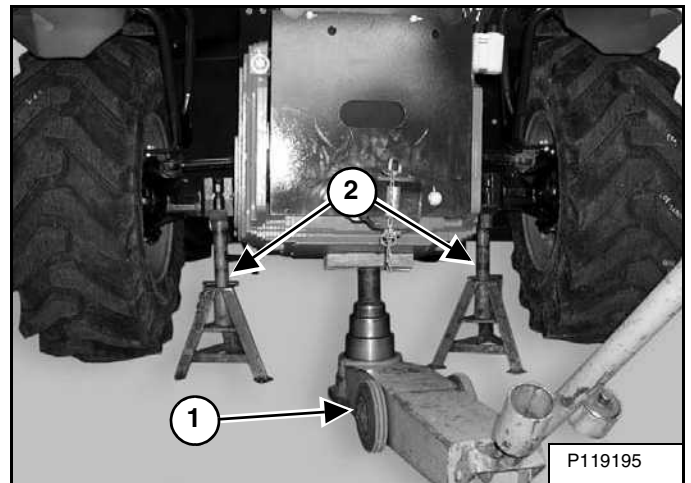

Put the floor jack (Item 1) under the center of the rear weight. Lift the telescopic handler and install jackstands (Item 2) [Figure 10-10-3].



**Bobcat®**



## OPERATOR CAB

### Description

The Bobcat telescopic handler has an operator cab (ROPS / FOPS) as standard equipment to protect the operator. The seat belt must be worn for ROPS / FOPS protection.

Check the ROPS / FOPS cab, mounting, and hardware for damage. Never modify the ROPS / FOPS cab. Replace the cab and hardware if damaged. See your Bobcat dealer for parts.

ROPS / FOPS - Roll Over Protective Structure per ISO 3471, Falling Object Protective Structure per ISO 3449 (FOPS Level II) and OECD code 4, code 9 and code 10.

Operator cab category 1 per EN 15695-1:2009.

The operator cab does not provide protection against hazardous substances. Do not use this machine under conditions requiring protection against hazardous substances.



**Never modify operator cab by welding, grinding, drilling holes or adding attachments unless instructed to do so by Bobcat Company. Do not operate without right window. Changes to the cab can cause loss of operator protection from rollover and falling objects, and result in serious injury or death.**

W-2906-0211

## Cab Door

Figure 10-20-1

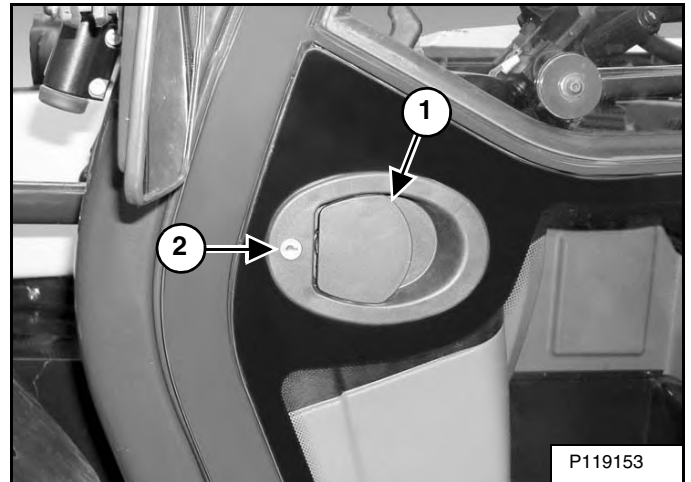
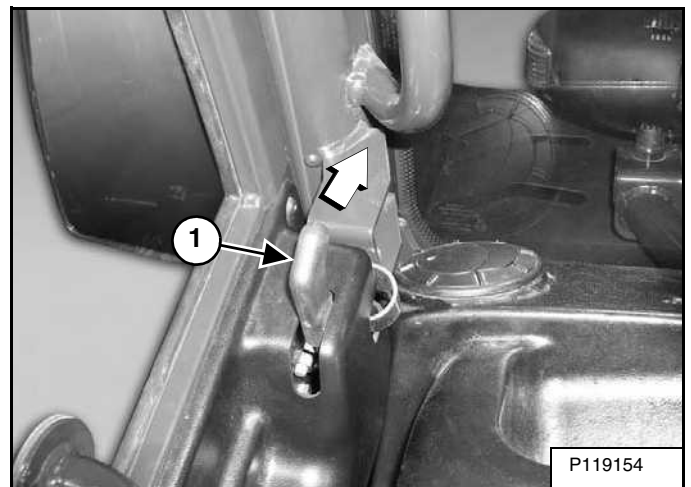

Figure 10-20-2



The cab door can be opened from the outside of the cab using the latch (Item 1) [Figure 10-20-1] and opened from the inside of the cab when you push the lever (Item 1) [Figure 10-20-2] (as shown).

The cab door can be locked (Item 2) [Figure 10-20-1] with the same key as the starter switch.

## OPERATOR CAB (CONT'D)

### Cab Door Window

Figure 10-20-3

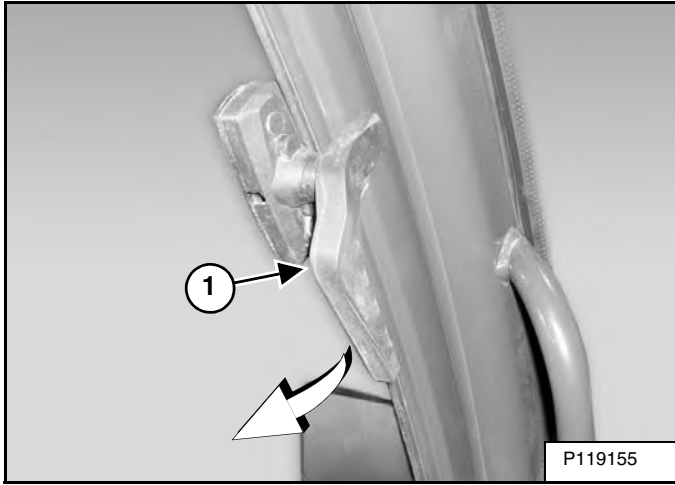

Turn the handle (Item 1) [Figure 10-20-3] (as shown) to unlock the window. Push the window fully open until it latches against the cab.

Figure 10-20-4

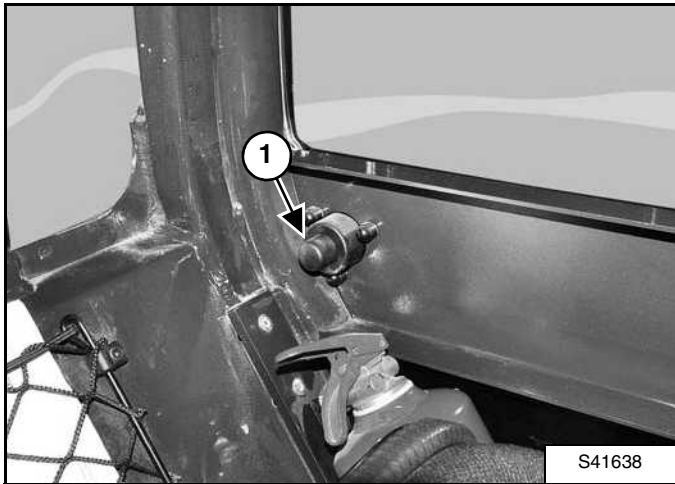

Push the knob (Item 1) [Figure 10-20-4] inside the cab to disengage the latch and close the window.

Figure 10-20-5

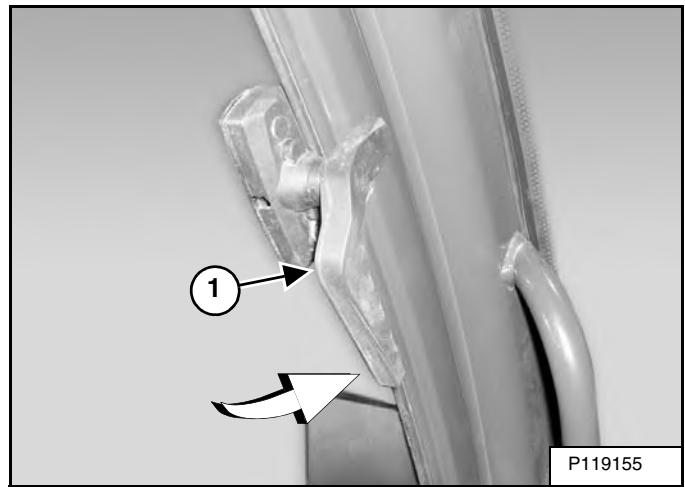

Turn the handle (Item 1) [Figure 10-20-5] back into the original position (as shown) to lock the window.

## OPERATOR CAB (CONT'D)

### Rear Cab Window

Figure 10-20-6

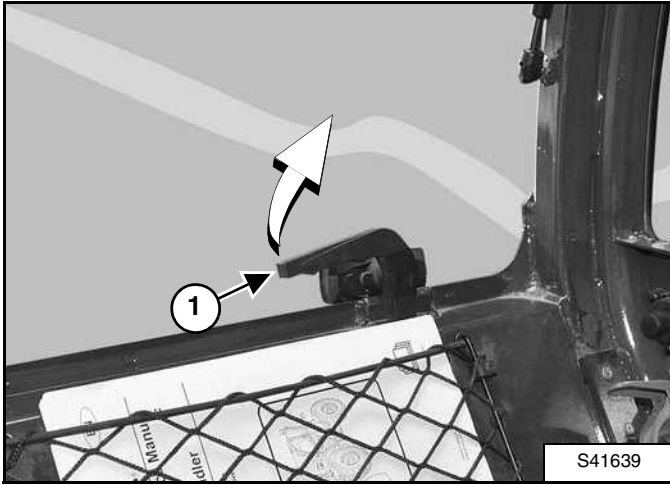

Turn the handle (Item 1) [Figure 10-20-6] (as shown) to unlock the rear window.

Push the rear window open until in fully open position.

### Cab Light

Figure 10-20-7

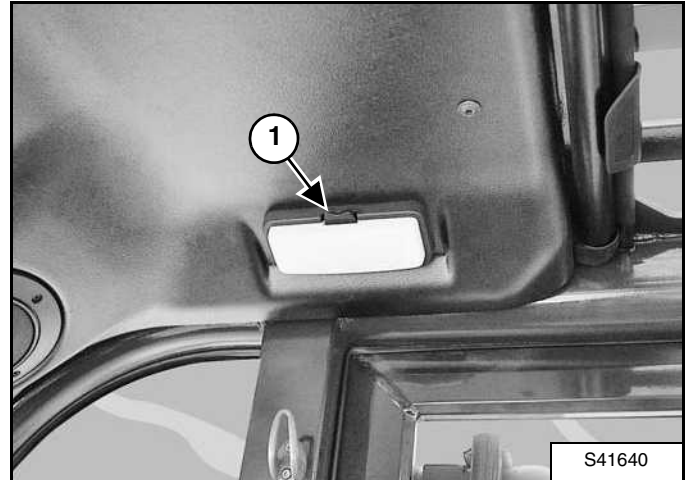

The cab light [Figure 10-20-7] is located above the operator's left shoulder.

Move the switch to the left or the right (Item 1) to turn the light ON. Move the switch to the center position (Item 2) [Figure 10-20-7] to turn the light OFF.



**Bobcat®**

## TRANSPORTING THE TELESCOPIC HANDLER ON A TRAILER

### Loading And Unloading

Figure 10-30-1



The telescopic handler must be loaded backward on the trailer.

The rear of the trailer must be blocked or supported (Item 1) [Figure 10-30-1] when loading or unloading the telescopic handler to prevent the front end of the trailer from raising up.

Be sure the transport and towing vehicles are of adequate size and capacity. For the weight of the TL358(D)(H) telescopic handler, (See Weights on Page SPEC-10-3.) and for the weight of the TL358(D)(H)CW telescopic handler, (See Weights on Page SPEC-10-15.)

## WARNING

### AVOID SERIOUS INJURY OR DEATH

Adequately designed ramps of sufficient strength are needed to support the weight of the machine when loading onto a transport vehicle. Wood ramps can break and cause personal injury.

W-2058-0807

## Fastening

Figure 10-30-2

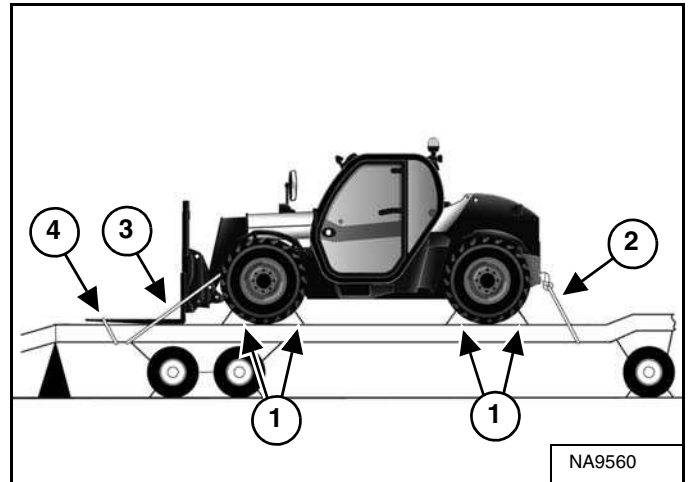

Fasten the telescopic handler to the transport vehicle to prevent it from moving during sudden stops or when going up or down slopes.

- Block the wheels (Item 1) [Figure 10-30-2].
- Use chains to fasten the machine frame to the transport vehicle (Items 2 and 3) [Figure 10-30-2]. Use chain binders to tighten the chains.
- Attach the forks or bucket attachment to the transport vehicle (Item 4) [Figure 10-30-2].



**Bobcat®**

## TOWING THE TELESCOPIC HANDLER

### Procedure

The telescopic handler can be towed a short distance such as removing it from mud or loading onto a transport vehicle.

Tow the telescopic handler at a slow speed, not exceeding 5 km/h (3 mph). Do not tow the machine for more than 3 minutes.



## WARNING

**UNEXPECTED MACHINE MOVEMENT CAN CAUSE SERIOUS INJURY OR DEATH**

- Block wheels to prevent roll away before adjusting screws to bypass the park brake system.
- Return adjustment screws to the operating position before operating the machine.

W-2808-0909

Block the wheels to prevent the machine from rolling.

### Disengaging The Parking Brake

The brakes are engaged by spring pressure and released by hydraulic pressure. The parking brake must be released manually before towing. Only the front axle has brakes.

The following procedure describes how to release the brakes:

Figure 10-40-1

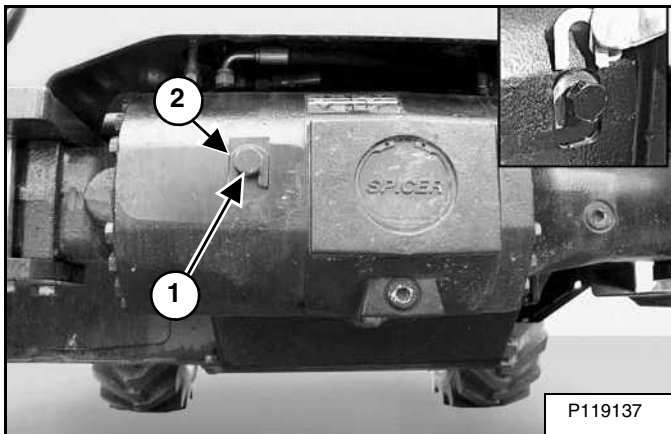

Loosen the two bolts (Item 1) (the bolts and spacers are located on both the front and rear side of the front axle) until the slotted spacers (Item 2) [Figure 10-40-1] can be removed from under the bolt heads.

Remove the spacers (Item 2) [Figure 10-40-1] and save for reuse.

Figure 10-40-2

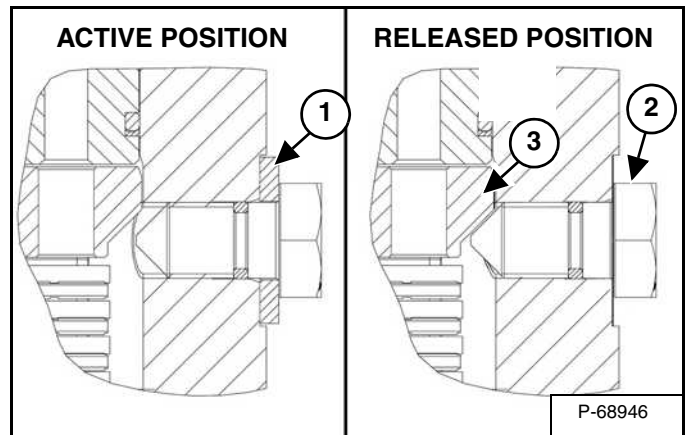

After removing the spacers (Item 1), evenly tighten the front and rear bolts (Item 2) to hold the parking brake piston (Item 3) [Figure 10-40-2] in the released position.

The brakes are now released for towing the machine.

**NOTE: The parking brake will not work until the adjustment screw is returned to the original position.**

## TOWING THE TELESCOPIC HANDLER (CONT'D)

### Procedure (Cont'd)

#### Disengaging The Transmission

Raise the engine cover.

Figure 10-40-3

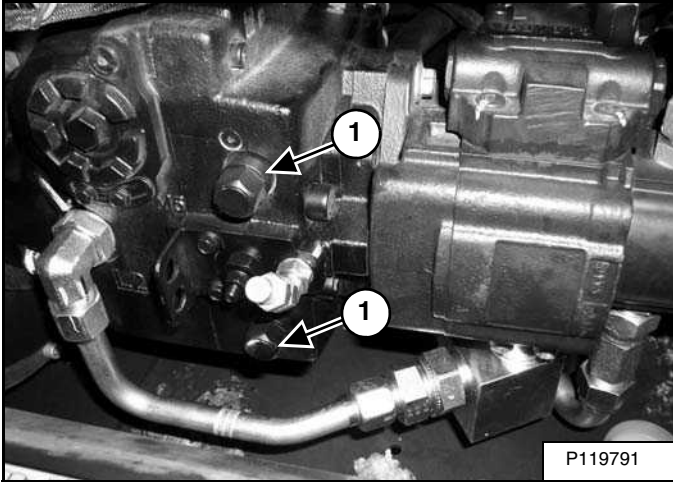

Locate the two identical multi-function valves (Item 1) [Figure 10-40-3] on the hydrostatic transmission pump.

Loosen the valves (Item 1) [Figure 10-40-3] by turning them three times anticlockwise.

**NOTE: Do not turn more than three times. This can result in leakage.**

This action will bypass the oil flow of the hydrostatic transmission.

Tow the telescopic handler at a slow speed, not exceeding 5 km/h (3 mph). Do not tow the machine for more than three minutes.

#### Engaging The Transmission

Tighten the valves (Item 1) [Figure 10-40-3] to 70 N•m (52 ft-lb) torque to re-engage the hydrostatic transmission.

## WARNING

### UNEXPECTED MACHINE MOVEMENT CAN CAUSE SERIOUS INJURY OR DEATH

- Block wheels to prevent roll away before adjusting screws to bypass the park brake system.
- Return adjustment screws to the operating position before operating the machine.

W-2808-0909

Block the wheels to prevent the machine from rolling.

After towing is completed, reverse the procedure above [Figure 10-40-3].

#### Engaging The Parking Brake

Figure 10-40-4

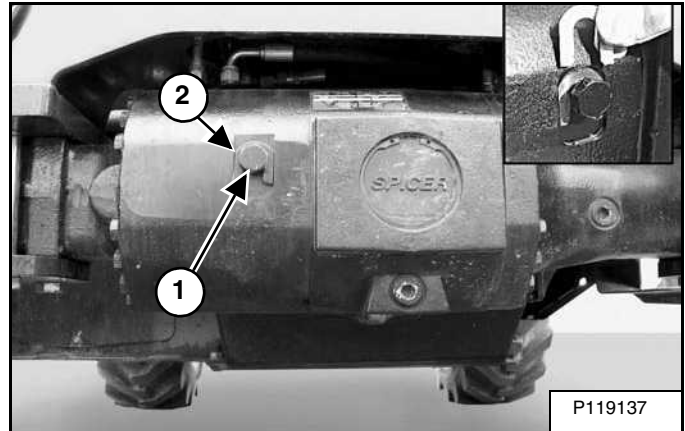

Loosen the two bolts (Item 1) until the spacers (Item 2) [Figure 10-40-4] can be installed under the bolt heads (the bolts and spacers are located on both the front and rear side of front axle).

Figure 10-40-5

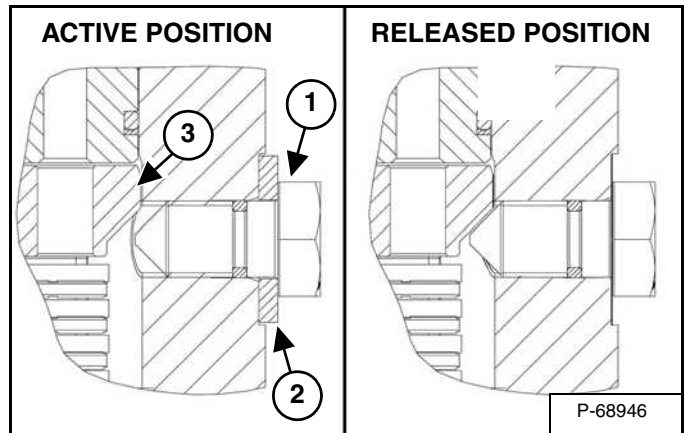

Evenly tighten the front and rear bolts (Item 1) to hold the spacers (Item 2) [Figure 10-40-4] and [Figure 10-40-5].

Tighten the bolts to 95 - 115 N•m (70 - 85 ft-lb) torque.

This will allow the park brake piston (Item 3) [Figure 10-40-5] to be active again.



## TOWING THE TELESCOPIC HANDLER (CONT'D)

### Procedure (Cont'd)

#### *Towing Points*

**Figure 10-40-6**

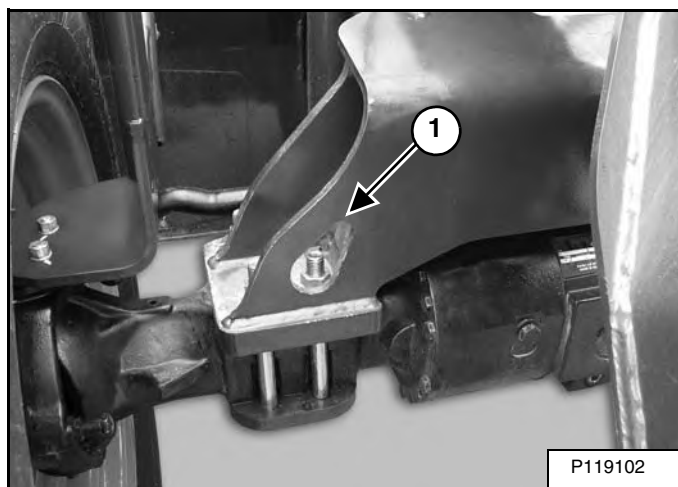

**Figure 10-40-7**

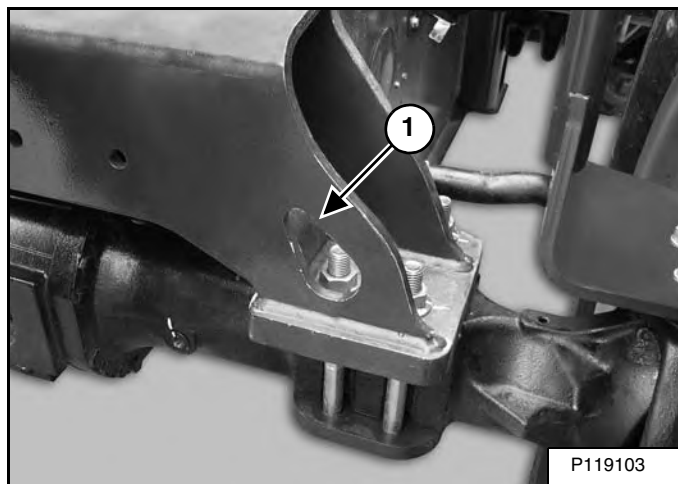

Use the two front transportation fastening points (Item 1) [Figure 10-40-6] and [Figure 10-40-7] for towing.



**Bobcat®**

## SERVICE SCHEDULE

### Maintenance Intervals

Maintenance work must be done at regular intervals. Failure to do so will result in excessive wear and early failures.

The service schedule is a guide for correct maintenance of the Bobcat telescopic handler.

During service, record:

- The machine operating hours.
- Maintenance procedures that are performed.

#### *Every 10 Hours (Before Starting The Telescopic Handler)*

- **Engine Oil** - Check level and add as needed. Do not overfill. Check engine for oil leaks. (See page 10-90-1)
- **Engine Air Filters and Air System** - Check condition indicator and empty dust cup as needed. Check for leaks. (See page 10-60-1)
- **Engine Cooling System** - Check oil cooler, radiator and air conditioner condenser. Check coolant level cold in reservoir. Add premixed coolant as necessary. (See page 10-70-1) Check cooling system for leaks.
- **Exhaust System** - Check exhaust system and exhaust aftertreatment components for leaks.
- **Hydraulic Fluid** - Check fluid level and add as needed. (See page 10-100-1)
- **Fuel Filter, Primary** - Check display panel. Remove the trapped water. (See page 10-80-2)
- **Seat Belt** - Check the condition of seat belt. Clean or replace seat belt retractors as needed. Clean dirt and debris from moving parts. (See Operation & Maintenance Manual for more information)
- **Back-up Alarm (if equipped)** - Check for proper function. Service as necessary. (See Operation & Maintenance Manual for more information)
- **Service Brakes** - Check for function. Service as necessary.
- **Parking Brakes** - Check for function. Adjust or service as necessary.
- **Tires** - Check for wear or damage. Inflate to correct pressure. Be sure all tires are inflated to the same pressure. Use only approved tires. (See page 10-140-1)
- **Wheel Nuts** - Perform every 8 hours or daily for the first week, then as scheduled. Check for loose wheel nuts and tighten to correct torque. (See page 10-140-1)
- **Safety Signs and Safety Treads and Mirrors** - Check for damaged signs (decals), safety treads and mirrors. Replace any signs, safety treads or mirrors that are damaged or worn. (See Operation & Maintenance Manual for more information)
- **Tilt Cylinder Rod End** - Lubricate with multipurpose lithium based grease. (See page 10-120-1)
- **Attachment Carrier Pins** - Lubricate with multipurpose lithium based grease. (See page 10-120-1)

#### *Every 50 Hours*

- **Fuel Filter, Primary** - Replace primary filter element the first time, then as scheduled. (See page 10-80-2)
- **Fuel Filter, Secondary** - Replace secondary filter element the first time, then as scheduled. (See page 10-80-4)
- **Engine Cooling System** - Clean debris from radiator, air cooler, hydraulic fluid cooler, air conditioning condenser (if equipped), and grille. (See page 10-70-1)
- **Engine Oil and Filter** - Replace oil and filter the first time, then as scheduled. (See page 10-90-2)
- **Hydraulic / Hydrostatic Fluid Filter** - Replace the filter element the first time, then as scheduled. Use a genuine Bobcat filter. (See page 10-100-3)
- **Air Conditioning Belt (if equipped)** - Check condition. Replace as needed. (See page 80-20-2)
- **Articulation Pins, Axle Oscillation (Front/Rear), Boom Pivot, Lift Cylinder, Self Leveling Cylinder** - Lubricate with multipurpose lithium based grease. (See page 10-120-1)
- **Telescopic Boom Wear Pads** - Lubricate with multipurpose lithium based grease. (See page 10-120-1)
- **Hydraulic Hoses, Tubelines and Connections** - Check for leaks. Repair or replace as needed.
- **Harnesses** - Check condition. Repair or replace as needed.

**WARNING**

### AVOID INJURY OR DEATH

**Instructions are necessary before operating or servicing machine. Read and understand the Operation & Maintenance Manual, Operator's Handbook and signs (decals) on machine. Follow warnings and instructions in the manuals when making repairs, adjustments or servicing. Check for correct function after adjustments, repairs or service. Untrained operators and failure to follow instructions can cause injury or death.**

W-2003-0807

## SERVICE SCHEDULE (CONT'D)

### Maintenance Intervals (Cont'd)

#### *Every 100 Hours*

- **LLMC System** - Test the LLMC calibration the first time, then as scheduled. (See page 60-180-4)
- **Wheel Nuts** - Check for loose wheel nuts and tighten to correct torque. (See page 10-140-1)
- **Planetary Carriers** - Replace the fluid the first time, then as scheduled. (See page 10-110-1)
- **Axle and Differential Fluid** - Replace the fluid the first time, then as scheduled. (See page 10-110-2)
- **Reduction Box Fluid** - Replace the fluid the first time, then as scheduled. (See page 10-110-4)

#### *Every 250 Hours Or Every 12 Months*

- **LLMC System** - Test the LLMC calibration. (See page 60-180-4)
- **Planetary Carriers** - Check level. (See page 10-110-1)
- **Axle and Differential Fluid** - Check level. (See page 10-110-2)
- **Reduction Box Fluid** - Check level. (See page 10-110-4)

#### *Every 500 Hours Or Every 12 Months*

- **Fuel Filter, Primary** - Clean and check primary filter element. (See page 10-80-2)
- **Engine Oil and Filter** - Replace oil and filter. (See page 10-90-2)
- **Engine Cooling System** - Check coolant concentration (with a refractometer). Replace as needed. (See page 10-70-2)
- **Air Conditioning Belt (if equipped)** - Check condition. Replace as needed. (See page 80-20-2)
- **Hydraulic / Hydrostatic Fluid Filter** - Replace the filter element. Use a genuine Bobcat filter. (See page 10-100-3)
- **Hydraulic Tank Breather** - Replace the hydraulic tank breather. (See page 10-100-5)
- **Axle and Differential Fluid** - Replace the fluid. (See page 10-110-2) Maximal service time is 800 hours.
- **Reduction Box Fluid** - Replace the fluid. (See page 10-110-4) Maximal service time is 800 hours.
- **Telescopic Boom Wear Pads** - Check for wear. Replace as necessary.
- **Service Brake Pedal Spring** - Lubricate with multipurpose lithium based grease.
- **Cab Air Filter** - Check filter condition. Replace as necessary. Check for damage. (See page 80-20-1)

#### *Every 750 Hours Or Every 12 Months*

- **Planetary Carriers** - Replace the fluid. (See page 10-110-1)
- **Axle and Differential Fluid** - Replace the fluid. (See page 10-110-2)
- **Reduction Box Fluid** - Replace the fluid. (See page 10-110-4)

#### *Every 1000 Hours Or Every 12 Months*

- **Battery and Cable Connectors** - Check voltage. Check terminals for good contact and presence of protective grease. (See page 60-20-1)
- **Fuel Filter, Primary** - Replace primary fuel filter element. (See page 10-80-2)
- **Fuel Filter, Secondary** - Replace secondary fuel filter element. (See page 10-80-4)
- **Engine Mounts** - Tighten. Replace if damaged.
- **Engine Air Filter** - Replace the outer filter element. (See page 10-60-1)
- **Charge Air Cooler** - Check entry area.
- **Alternator Belt** - Check condition. Replace as needed. (See page 60-30-2)
- **Air Conditioning Belt (if equipped)** - Check condition. Replace as needed. (See page 80-20-2)
- **Hydraulic Fluid** - Replace the fluid. (See page 10-100-2)
- **Fastenings, Hose Unions and Clips** - Replace if damaged.

#### *Every 3000 Hours*

- **Alternator Belt and Tensioning Pulley** - Replace the belt and tensioning pulley. (See page 60-30-2)

## **SERVICE SCHEDULE (CONT'D)**

### **Maintenance Intervals (Cont'd)**

*Every 24 Months*

- **Coolant** - Replace the coolant. (See page 10-70-2)



**Bobcat®**

## AIR CLEANER SERVICE

### Replacing Filter Elements

#### Outer Filter

Figure 10-60-1

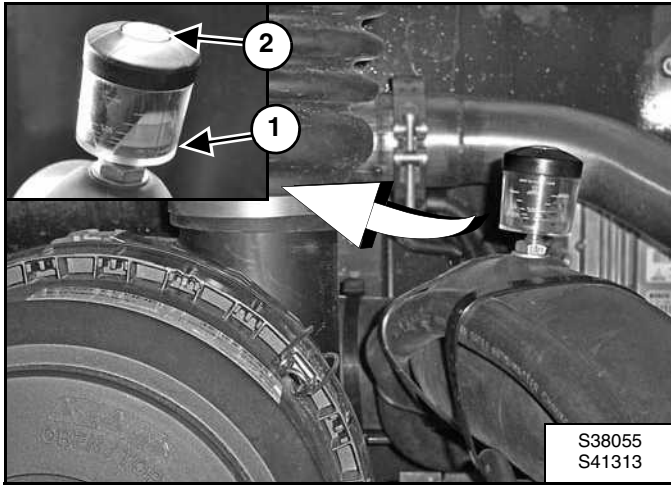

Replace the large (outer) filter element only when the yellow ring has reached the red zone on the condition indicator (Item 1) [Figure 10-60-1].

**NOTE:** Before replacing the filter element, push the button on the condition indicator (Item 2) [Figure 10-60-1]. Start the engine. If the yellow ring of the condition indicator does not reach the red zone, do not replace the filter element.

Figure 10-60-2

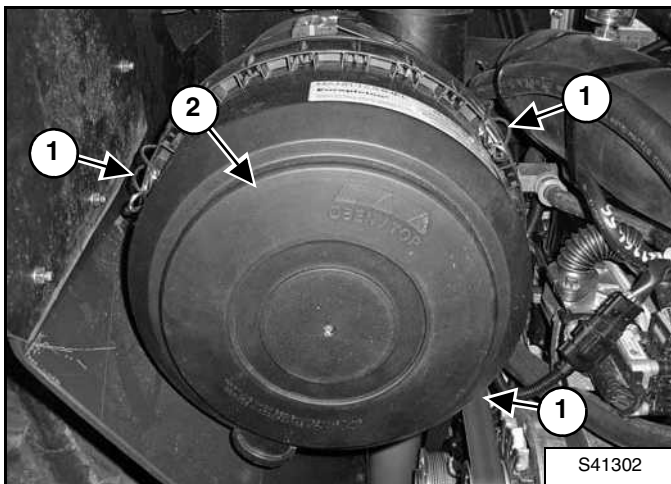

Loosen the filter housing clamps (Item 1) [Figure 10-60-2].

Remove the dust cover (Item 2) [Figure 10-60-2].

Figure 10-60-3

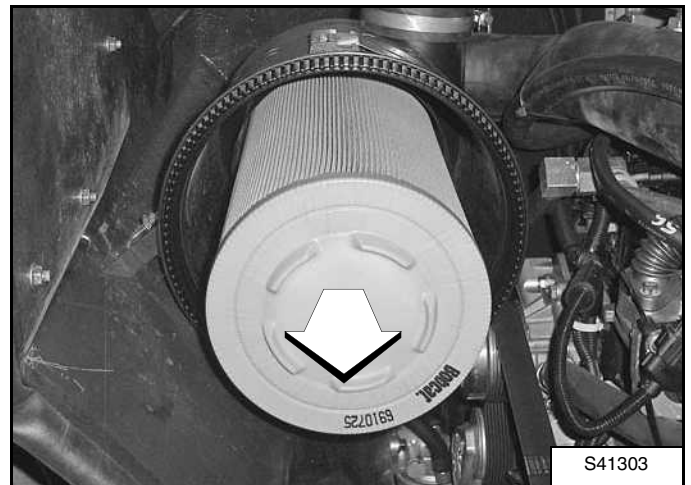

Pull the outer filter element straight out [Figure 10-60-3] and discard.

**NOTE:** Make sure all sealing surfaces are free of dirt and debris. DO NOT use compressed air.

Install a new outer element.

Figure 10-60-4

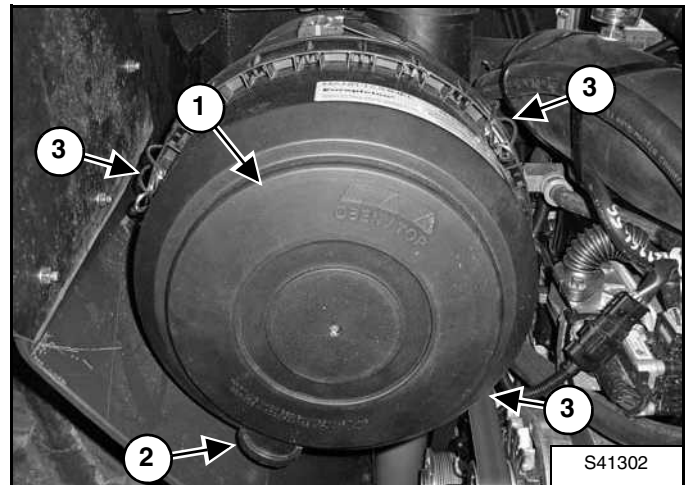

Install the dust cover (Item 1) with the dust extractor (Item 2) [Figure 10-60-4] facing down.

Fasten the filter housing clamps (Item 3) [Figure 10-60-4].

## AIR CLEANER SERVICE (CONT'D)

### Replacing Filter Elements (Cont'd)

#### *Inner Filter*

Only replace the inner filter element under the following conditions:

- Replace the inner filter element every third time the outer filter is replaced.
- After the outer element has been replaced, start the engine and run at full rpm. If the yellow ring is still in the red zone of the indicator window, replace the inner filter element.

Remove the outer element.

**NOTE: Make sure all sealing surfaces are free of dirt and debris. DO NOT use compressed air.**

**Figure 10-60-5**

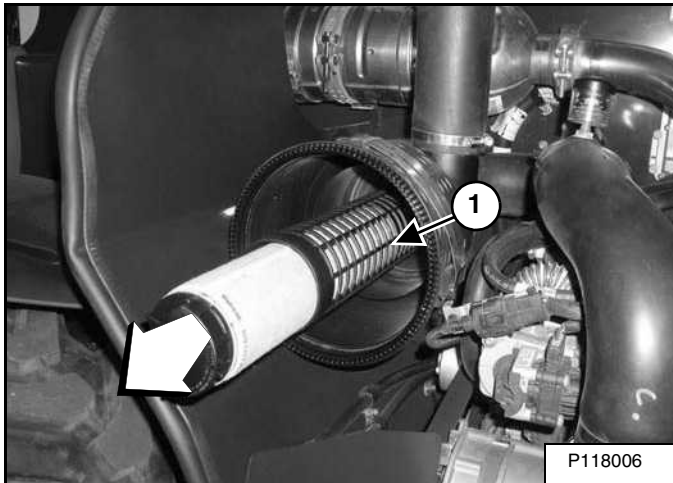

Remove the inner filter element (Item 1) [Figure 10-60-5] and install a new element.

Install the outer element.

Install the dust cover (Item 2) with the dust extractor (Item 3) [Figure 10-60-4] facing down.

Fasten the filter housing clamps (Item 1) [Figure 10-60-4].



This as a preview PDF file from [best-manuals.com](https://best-manuals.com)



Download full PDF manual at [best-manuals.com](https://best-manuals.com)