

# 888P/888P4A EXCAVATOR TABLE OF CONTENTS

DIVISION/SECTION	SECTION N°	FORM N°
<b>1 GENERAL</b>		
Sectional Index		7-33020
Safety, General Information and Torque Specifications.....	1001 *	8-86530
Specifications .....	1002	7-31291
(888P Serial Number : Prior to 6199)		
(888P4A Serial Number : Prior to 7699)		
Specifications .....	1002	7-40200
(888P Serial Number : 6201 and After)		
(888P4A Serial Number : 7701 and After)		
<b>2 ENGINE</b>		
Sectional Index		7-33030
Engine Removal and Installation.....	2000	7-31300
Radiator, Oil Cooler and Coolant Recovery System .....	2001	7-31310
Engine Specifications.....	2401	8-26063
Cylinder Head and Drive Train.....	2415	8-26073
Cylinder Block .....	2425	8-26084
Lubrication System.....	2445	8-26093
Cooling System .....	2455	8-26103
Turbocharger .....	2465	8-26110
Turbocharger Failure Analysis.....	2565	9-78235
<b>3 FUEL SYSTEM</b>		
Sectional Index		7-33040
Fuel System and Filters .....	3410	8-26131
Fuel Injection Pump and Drive Gear .....	3412	8-26143
Fuel Injectors.....	3413	8-26152
<b>4 ELECTRICAL</b>		
Sectional Index		7-33050
Electrical Schematics and Troubleshooting.....	4001 *	7-31331
Battery Testing, Maintenance and Booster Battery Connections .....	4002	7-31340
Starter Motor .....	4003	7-31350
Alternator.....	4004	7-31360
<b>5 STEERING</b>		
Sectional Index		7-33060
Steering Hand Pump.....	5002	7-31370
Steering Cylinder.....	5003	7-31380
(888P Serial Number : Prior to 6199)		
(888P4A Serial Number : Prior to 7699)		
Steering Cylinder.....	5003	7-40590
(888P Serial Number : 6201 and After)		
(888P4A Serial Number : 7701 and After)		

THIS TABLE OF CONTENTS REPLACES DON 7-32911

DIVISION/SECTION	SECTION N°	FORM N°
<b>6 POWER TRAIN</b>		
Sectional Index		7-33071
Swing Motor and Reduction Gears .....	6003	7-31390
Front Axle .....	6004	7-31400
(888P Serial Number : Prior to 6199)		
(888P4A Serial Number : Prior to 7699)		
Front Axle .....	6004	7-40120
(888P Serial Number : 6201 and After)		
(888P4A Serial Number : 7701 and After)		
Rear Axle .....	6005	7-31410
(888P Serial Number : Prior to 6199)		
(888P4A Serial Number : Prior to 7699)		
Rear Axle .....	6005	7-40130
(888P Serial Number : 6201 and After)		
(888P4A Serial Number : 7701 and After)		
Drive Shaft .....	6006	7-31420
(888P Serial Number : Prior to 6199)		
(888P4A Serial Number : Prior to 7699)		
Drive Shaft .....	6006	7-40140
(888P Serial Number : 6201 and After)		
(888P4A Serial Number : 7701 and After)		
Travel Motor .....	6007	7-31430
(888P Serial Number : Prior to 6199)		
(888P4A Serial Number : Prior to 7699)		
Travel Motor .....	6007	7-40150
(888P Serial Number : 6201 and After)		
(888P4A Serial Number : 7701 and After)		
Drop Box .....	6008	7-31440
(888P Serial Number : Prior to 6199)		
(888P4A Serial Number : Prior to 7699)		
Drop Box .....	6008	7-40160
(888P Serial Number : 6201 and After)		
(888P4A Serial Number : 7701 and After)		
<b>7 BRAKES</b>		
Sectional Index		7-33080
Service Brakes .....	7002	7-31450
(888P Serial Number : Prior to 6199)		
(888P4A Serial Number : Prior to 7699)		
Service Brakes .....	7002	7-40630
(888P Serial Number : 6201 and After)		
(888P4A Serial Number : 7701 and After)		
Parking Brake .....	7003	7-31460
(888P Serial Number : Prior to 6199)		
(888P4A Serial Number : Prior to 7699)		
Parking Brake .....	7003	7-40520
(888P Serial Number : 6201 and After)		
(888P4A Serial Number : 7701 and After)		

DIVISION/SECTION	SECTION N°	FORM N°
<b>8 HYDRAULICS</b>		
Sectional Index		7-33091
Hydraulic Components .....	8000	7-31470
Hydraulic Troubleshooting .....	8001 *	7-31480
(888P Serial Number : Prior to 6199)		
(888P4A Serial Number : Prior to 7699)		
Hydraulic Troubleshooting .....	8001 *	7-40340
(888P Serial Number : 6201 and After)		
(888P4A Serial Number : 7701 and After)		
Low Pressure Pump .....	8002	7-31490
High Pressure Pump .....	8003	7-31500
Attachment Valve .....	8004	7-31510
Drive Control Valve .....	8005	7-31520
(888P Serial Number : Prior to 6199)		
(888P4A Serial Number : Prior to 7699)		
Drive Control Valve .....	8005	7-40530
(888P Serial Number : 6201 and After)		
(888P4A Serial Number : 7701 and After)		
Option Control Valve .....	8006	7-31530
Stabilizer Valve .....	8007	7-31540
Swing Brake Release Valve .....	8008	7-31550
Swing Control Valve .....	8009	7-31560
Anti-Surge Valve .....	8010	7-31570
Hydraulic Swivel .....	8011	7-31580
(888P Serial Number : Prior to 6199)		
(888P4A Serial Number : Prior to 7699)		
Hydraulic Swivel .....	8011	7-40540
(888P Serial Number : 6201 and After)		
(888P4A Serial Number : 7701 and After)		
Drive Speed Limiter .....	8012	7-31590
Foot Brake and Travel Control Valve .....	8013	7-31600
Option Foot Control Valve .....	8014	7-31610
Hand Control Valves .....	8015	7-31620
Hydraulic Oil Tank .....	8016	7-31630
Forward and Reverse Travel Control Valve .....	8017	7-32640
Attachment Cylinders .....	8018	7-31640
Accumulators .....	8020	7-32400
Clamshell Swing Motor .....	8024	7-40100
Clamshell Swing Safety Valve .....	8025	7-40110
<b>9 CHASSIS</b>		
Sectional Index		7-33100
Upperstructure and Turntable Bearing .....	9001	7-31660
Boom Dipper and Bucket .....	9002	7-31670
Stabilizer and Dozer Blace .....	9003	7-31680
Cab Servicing .....	9004	7-31690

\* Schematic Set Sections



## Sectional Index

	SECTION NO.
1 GENERAL	
C Capacities .....	1002
E Electrical System Specifications .....	1002
Engine Specifications .....	1002
Engine Special Torques .....	1002
F Fuel Specifications .....	1002
G General Information .....	1001
H Hydraulic Fittings Special Torques .....	1001
Hydraulic Specifications .....	1002
R Run-In Instructions .....	1002
S Safety Warnings .....	1001
Standard Nut and Bolt Torques .....	1001
Steering Specifications .....	1002
T Transmission Specifications .....	1002

## Sectional Index

		SECTION NO.
<b>2</b>	<b>ENGINE</b>	
<b>B</b>	Bearings .....	2425
	Belt Tensioner .....	2455
<b>C</b>	Camshaft .....	2425
	Cooling System (Engine)	
	Cleaning and Maintenance .....	2425
	Crankshaft Pressure Check (Blow By) .....	2425
	Crankshaft .....	2425
	Cylinder Block .....	2425
	Cylinder Head .....	2415
<b>E</b>	Engine Installation .....	2000
	Engine Removal .....	2000
	Exhaust Valves .....	2415
	Expansion Plug Replacement	
	Expansion Cylinder Block .....	2425
	Expansion Cylinder Head .....	2415
<b>F</b>	Fan Pulley .....	2455
	Flywheel .....	2425
<b>I</b>	Intake Valves .....	2415
<b>L</b>	Lubrication System .....	2445
<b>O</b>	Oil Filter Housing .....	2445
	Oil Pan .....	2445
	Oil Pressure Relief Valve .....	2445
	Oil Pump .....	2445
	Oil Seals .....	2425
<b>P</b>	Pistons .....	2425
<b>R</b>	Radiator and Oil Cooler Installation .....	2001
	Radiator and Oil Cooler Removal .....	2001
	Rocker Arms .....	2415
	Rods .....	2425
<b>S</b>	Sleeves .....	2425
<b>T</b>	Thermostat .....	2455
	Top Dead Centre (How to Locate) .....	2415
	Turbocharger .....	2465
	Turbocharger Failure Analysis .....	2565
<b>V</b>	Valve Guide Replacement .....	2415
	Valve Dye Pattern Analysis .....	2415
	Valve Seats .....	2415
	Valve Train .....	2415
<b>W</b>	Water Pump .....	2455

# Section

# 1001

SAFETY, GENERAL INFORMATION  
AND TORQUE SPECIFICATIONS

## TABLE OF CONTENTS

SAFETY .....	3
GENERAL INFORMATION .....	5
STANDARD TORQUE DATA FOR NUTS AND BOLTS .....	6
TORQUE DATA FOR HYDRAULIC FITTINGS .....	7



# SAFETY



*This symbol means ATTENTION! BECOME ALERT! YOUR SAFETY IS INVOLVED. The message that follows the symbol contains important information about safety. Carefully read the message. Make sure you fully understand the causes of possible injury or death.*

1-1-C

To prevent injury always follow the Warning, Caution and Danger notes in this section and throughout the manual.

Put the warning tag shown below on the key for the keyswitch when servicing or repairing the machine. One warning tag is supplied with each machine. Additional tags Part Number 331-4614 are available from your service parts supplier.

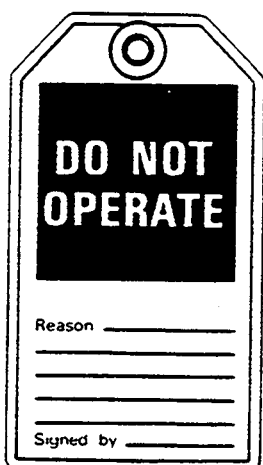

B004

**WARNING:** Before starting engine, study Operator's Manual safety messages. Read all safety signs on machine. Clear the area of other persons. Learn and practice safe use of controls before operating.

**!** It is your responsibility to understand and follow manufacturers instructions on machine operation, service, and to observe pertinent laws and regulations. Operator's and Service Manuals may be obtained from your J.I. Case dealer

45-2

**WARNING:** If you wear clothing that is too loose or do not use the correct safety equipment for your job, you can be injured. Always wear clothing that will not catch on objects. Extra safety equipment that can be required includes hard hat, safety shoes, ear protection, eye or face protection, heavy gloves and reflector clothing

45-3-A

**!** **WARNING:** Read the operator's manual to familiarize yourself with the correct control functions.

46-27

**!** **WARNING:** When working in the area of the fan belt with the engine running, avoid loose clothing if possible, and use extreme caution.

35-4

**!** **WARNING:** Operate the machine and equipment controls from the seat position only. Any other method could result in serious injury.

48-55

**!** **WARNING:** When doing checks and tests on the equipment hydraulics, follow the procedures as they are written. DO NOT change the procedure.

47-44

**!** **WARNING:** This is one man machine, no riders allowed.

35-8

**!** **WARNING:** When putting the hydraulic cylinders on this machine through the necessary cycles to check operation or to remove air from a circuit, make sure all people are out of the way.

47-45



**WARNING:** Use insulated gloves or mittens when working with hot parts.

47-41A



**CAUTION:** Lower all attachments to the ground or use stands to safely support the attachments before you do any maintenance or service.

49-11



**CAUTION:** Pin sized and smaller streams of hydraulic oil under pressure can penetrate the skin and result in serious infection. If hydraulic oil under pressure does penetrate the skin, seek medical treatment immediately. Maintain all hoses and tubes in good condition. Make sure all connections are tight. Make a replacement of any tube or hose that is damaged or thought to be damaged. **DO NOT** use your hand to check for leaks, use a piece of cardboard or wood.

40-6-A



**CAUTION:** When removing hardened pins such as a pivot pin, or a hardened shaft, use a soft head (brass or bronze) hammer or use a driver made from brass or bronze and a steel head hammer.

46-17



**CAUTION:** When using a hammer to remove and install pivot pins or separate parts using compressed air or using a grinder, wear eye protection that completely encloses the eyes (approved goggles or other approved eye protectors).

46-13



**CAUTION:** Use suitable floor (service) jacks or chain hoist to raise wheels or tracks off the floor. Always block machine in place with suitable safety stands.

40-7-A



**CAUTION:** When servicing or repairing the machine. Keep the shop floor and operator's compartment and steps free of oil, water, grease, tools, etc. Use an oil absorbing material and or shop cloths as required. Use safe practices at all times.

40-8



**CAUTION:** Some components of this machine are very heavy. Use suitable lifting equipment or additional help as instructed in this Service Manual.

40-10



**DANGER:** Engine exhaust fumes can cause death. If it is necessary to start the engine in a closed place, remove the exhaust fumes from the area with an exhaust pipe extension. Open the doors and get outside air into the area.

48-56



**DANGER:** When the battery electrolyte is frozen, the battery can explode if (1), you try to charge the battery, or (2), you try to jump start and run the engine. To prevent the battery electrolyte from freezing, try to keep the battery at full charge. If you do not follow these instructions, you or others in the area can be injured.

48-35



**DANGER:** Batteries contain acid and explosive gas. Explosions can result from sparks, flames or wrong cable connections. To connect the jumper cables correctly to the battery of this machine see the Operator's Manual. Failure to follow these instructions can cause serious injury or death.

## GENERAL INFORMATION

### CLEANING

Clean all metal parts except bearings, in mineral spirits or by steam cleaning. Do not use caustic soda for steam cleaning. After cleaning dry, and put oil on all parts. Clean oil passages with compressed air. Clean bearings in kerosene, dry the bearings completely and put oil on the bearings.

### INSPECTION

Check all parts when the parts are disassembled. Replace all parts that have wear or damage. Small scoring or grooves can be removed with a hone or crocus cloth. Complete visual inspection for indications of wear, pitting and the replacement of parts necessary will prevent early failures.

### BEARINGS

Check bearings for easy action. If bearings have a loose fit or rough action replace the bearing. Wash bearings with a good solvent or kerosene and permit to air dry. **DO NOT DRY BEARINGS WITH COMPRESSED AIR.**

### NEEDLE BEARINGS

Before you press needle bearings in a bore always remove any metal protrusions in the bore or edge of the bore. Before you press bearings into position put petroleum jelly on the inside and outside diameter of the bearings.

### GEARS

Check all gears for wear and damage. Replace gears that have wear or damage.

### OIL SEALS, O-RINGS AND GASKETS

Always install new oil seals, o-rings and gaskets. Put petroleum jelly on seals and o-rings.

### SHAFTS

Check all shafts that have wear or damage. Check the bearing and oil seal surfaces of the shafts for damage.

### SERVICE PARTS

Always install genuine Case service parts, when ordering refer to the Parts Catalog for the correct part number of the genuine Case replacement items. Failures due to the use of other than genuine Case replacement parts are not covered by warranty.

### LUBRICATION

Only use the oils and lubricants specified in the Operator's or Service Manual. Failures due to the use of non specified oils and lubricants are not covered by warranty.

## STANDARD TORQUE DATA FOR NUTS AND BOLTS

Where no special torque data is specified, the following torque figures should be applied. Threads should be lubricated with engine oil or chassis grease.

TORQUE SPECIFICATIONS $\pm$ 10%									
SIZE	GRADE 8.8			GRADE 10.9			GRADE 12.9		
	lb-ft	Nm	kg/m	lb-ft	Nm	kg/m	lb-ft	Nm	kg/m
5 mm	4	5.5	0.56	5.5	7.5	0.76	6.6	9	0.92
6 mm	6.6	9	0.92	9.2	12.5	1.27	11	15	1.53
8 mm	16.5	22.5	2.3	23	31.5	3.2	26.5	36	3.67
10 mm	32	44	4.5	45	62	6.3	55	75	7.65
12 mm	57	77.5	7.9	81	110	11.2	95	130	13.2
14 mm	88	120	12.2	125	170	17.3	155	210	21.4
16 mm	140	190	19.4	195	265	27	236	320	32.6
18 mm	192	260	26.5	269	365	37.2	320	435	44.3
20 mm	273	370	37.7	383	520	53	457	620	63.2
22 mm	369	500	51	516	700	71.4	619	840	85.6
24 mm	471	640	65.2	665	900	92	796	1080	110
27 mm	702	950	97	996	1350	137.7	1195	1620	165.2
30 mm	955	1300	132.5	1328	1800	183.6	1593	2160	220.3

## TORQUE DATA FOR HYDRAULIC FITTINGS

### FITTINGS, CONNECTIONS AND PLUGS

Diameter x Pitch	Newton / Metres	Pounds / Feet	Kilogram / Metres
10 mm x 1	20	14.5	2
12 mm x 1.5	35	26	3.6
14 mm x 1.5	45	33.2	4.6
16 mm x 1.5	60	44	6.1
18 mm x 1.5	70	51	7.1
22 mm x 1.5	100	73	10.2
27 mm x 2	200	147	20.4
33 mm x 2	280	207	28.6
42 mm x 2	380	281	38.8

### NUTS FOR TUBES AND HOSES

Diameter x Pitch	Newton / Metres	Pounds / Feet	Kilogram / Metres
16 mm x 1.5	20	14.5	2
18 mm x 1.5	35	26	3.6
20 mm x 1.45	45	33.2	4.6
24 mm x 1.5	60	44	6.1

### FLANGES

Diameter x Pitch	Newton / Metres	Pounds / Feet	Kilogram / Metres
8 mm x 1.5	28	21	2.9
10 mm x 1.5	55	41	5.6
12 mm x 1.75	90	67	9.2
14 mm x 2	145	107	14.8
16 mm x 2	230	170	23.5



# **Section 1002 SPECIFICATIONS**

**1002**

For 888P Excavators  
(888P Serial Number: Prior to 6199)  
(888P4A Serial Number: Prior to 7699)

## TABLE OF CONTENTS

MODEL AND SERIAL NUMBERS.....	3
<b>GENERAL SPECIFICATIONS</b>	
Capacities.....	4
Drive Speed.....	4
Electrical System.....	4
Fluids and Lubricants.....	5
Hydraulic System.....	5
Tires.....	7
Weights.....	7
<b>ENGINE SPECIFICATIONS</b>	
<b>IMPORTANT:</b> <i>This engine was made using the metric measurement system. All measurements and checks must be made with metric tools to make sure of an accurate reading when inspecting parts.</i>	
Running-In Instructions.....	10
Engine Cooling System.....	11
Engine Lubrication.....	11
General Engine Specifications	
General.....	12
Pistons and Connecting Rods.....	12
Main Bearings.....	12
Engine Lubricating System.....	12
Fuel System.....	13
Detailed Engine Specifications	
Cylinder Block.....	14
Service Cylinder Sleeves.....	14
Pistons.....	14
Piston Pins.....	14
Piston Rings.....	15
Cylinder Head.....	15
Lifters.....	15
Connecting Rods.....	15
Crankshaft.....	16
Camshaft.....	17
Turbocharger.....	17
Gear Train.....	17
Rocker Arm Assembly.....	17
Intake Valves.....	18
Exhaust Valves.....	18
Valve Springs.....	18
Special Torques.....	19
GENERAL DIMENSIONS.....	22
TRANSPORT DIMENSIONS.....	27



## MODEL AND SERIAL NUMBERS

When ordering parts or when requesting information or assistance, always give the identification numbers of your machine.

Write the model and serial numbers of your machine on the lines below.

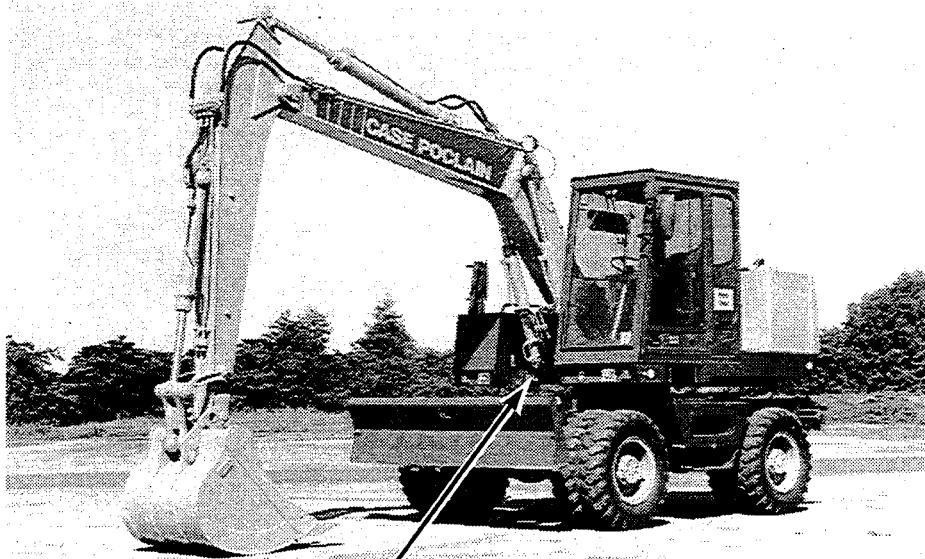

C14426A

Machine Model Number

Machine Serial Number

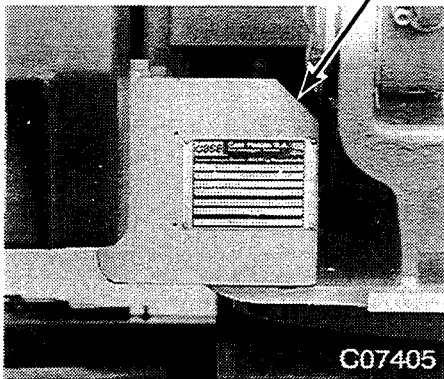

C07405

Engine Serial Number

High Pressure Pump Serial Number

Low Pressure Pump Serial Number

## GENERAL SPECIFICATIONS

### Capacities

Engine Oil Capacity (with filter change).....	15.4 litres	3.38 gallons
Engine Cooling System (with cab heater).....	19.2 litres	4.22 gallons
Fuel Tank.....	247 litres	54.34 gallons
Hydraulic Oil Reservoir Capacity.....	130 litres	28.6 gallons
Total Hydraulic System Capacity.....	205 litres	45.1 gallons
Swing Reduction Gear Capacity.....	3.5 litres	6.16 pints
Front Axle Capacity.....	16 litres	3.52 gallons
Rear Axle Capacity.....	21 litres	5.5 gallons
Axle Reduction Gear Housing Capacity (each).....	2.5 litres	4.4 pints

**NOTE:** These capacities are only a guide to the quantities. Always use the dipstick, sight gauge or level plug to make sure that fluid levels are correct.

### Drive speed

Drive speed.....	23 Km/h	23 Kph
------------------	---------	--------

### Electrical System

Type of System.....	24 volts, negative ground
---------------------	---------------------------

#### Alternator

Manufacturer.....	Bosch
Output.....	28 volts at 45 amperes
Resistance of rotor winding.....	9.0 ohms
Resistance of stator winding.....	0.22 ohms
Minimum brush length.....	14 mm (0.55 inch)

#### Batteries

Number of batteries required.....	2
Voltage of each battery.....	12 volts
Reserve capacity.....	160 minutes
Cold cranking capacity at -17°C (0°F).....	800 amperes
Load for capacity (load) test.....	400 amperes

#### Starter Motor

Manufacturer.....	Bosch
No load test at 27°C (80°F)	
Volts.....	23 volts
Current draw.....	85 amperes maximum
Armature speed.....	7000 rpm minimum
Brush length.....	8.5 mm (0.3125 inch) minimum
Armature run-out.....	0.03 mm (0.001 inch) maximum
Commutator diameter.....	42.5 mm (1.74 inch) minimum
Armature end play.....	0.05 to 0.4 mm (0.002 to 0.15 inch)

## Fluids and Lubricants

Batteries.....	Maintenance Free
Engine Coolant Solution.....	refer to page 10
Engine Lubrication.....	refer to page 10
Hydraulic Oil.....	Case Poclain Hydraulic Excavator Fluid
Axle Lubricant.....	Gear Lubricant EP 80W 90
Gear Box Lubricant.....	Gear Lubricant EP 80W 90
Swing Reduction Gear Lubricant.....	Gear Lubricant EP 80W 90
Turntable Ring Gear Lubricant.....	Case IH molydisulfide grease
Grease Fitting Lubricant.....	Case IH molydisulfide grease

## Hydraulic System

Engine no load governed speed.....	2140 to 2260 rpm
Engine idle speed.....	900 rpm

### PRESSURE SETTINGS:

Torque regulator valve (R.C) 120 L/mn Engine speed 2020 rpm at a pressure of.....	275 bar	3988 psi
Travel flow cut-off valve (A.D.LS2).....	405 to 415 bar	5873 to 6018 psi
Attachment flow cut-off valve (A.D.LS1).....	360 to 370 bar	5200 to 5365 psi
Load Sensing (L.S).....	18 to 19 bar	261 to 276 psi
Attachment valve bank main relief valve.....	425 to 450 bar	6163 to 6525 psi
Circuit relief valves:		
Boom: raising.....	380 to 405 bar	5510 to 5873 psi
Boom: lowering.....	390 to 425 bar	5655 to 6163 psi
Bucket: opening, closing.....	380 to 405 bar	5510 to 5873 psi
Dipper: extension, retracting.....	380 to 405 bar	5510 to 5873 psi
Swing: right, left.....	350 to 360 bar	5075 to 5220 psi
Travel: forward drive, reverse drive.....	420 to 435 bar	6090 to 6308 psi
Stabilizers and dozer blade: lowering.....	380 to 400 bar	5510 to 5800 psi
Stabilizers and dozer blade: raising.....	360 to 390 bar	5220 to 5655 psi
P4A Excavator stabilizers: raising and lowering.....	380 to 400 bar	5510 to 5800 psi
Boom and dipper load holding valve.....	390 to 410 bar	5655 to 5945 psi
Boom and dipper safety valve.....	390 to 410 bar	5655 to 5945 psi
Low flow (clamshell swing).....	130 to 150 bar	1885 to 2175 psi
Offset boom.....	180 to 200 bar	2610 to 2900 psi
Remote boom adjustment.....	180 to 200 bar	2610 to 2900 psi
Servo-unit pilot circuit.....	34 to 36 bar	493 to 522 psi
Travel pilot circuit.....	23 to 24 bar	334 to 348 psi
Stabilizer sequence:		
Stabilizer beam lowering.....	240 to 260 bar	3480 to 3770 psi
Stabilizer shoe closing.....	340 to 370 bar	4930 to 5365 psi
Dozer blade lowering sequence.....	340 to 360 bar	4930 to 5220 psi
Dozer blade ground pressure limiter.....	100 bar	1450 psi
Hydraulic drive motor regulation sequence.....	200 to 210 bar	2900 to 3045 psi
Stabilizer shoe opening pressure.....	80 to 120 bar	1160 to 1740 psi

## Steering:

Safety valve.....	175 to 185 bar	2538 to 2683 psi
Relief valves.....	200 to 220 bar	2900 to 3190 psi
Brake module make-and-break.....	120 to 160 bar	1740 to 2320 psi
Service brake pressure.....	45 to 60 bar	653 to 870 psi
Parking brake pressure.....	120 to 160 bar	1740 to 2320 psi
Accumulator pressure.....	65 bar	943 psi
Max. high pressure pump.....	255 L/mn	56.1 gpm
Flow setting valve rates:		
Boom, raising.....	168 to 175 L/mn	36.95 to 38.49 gpm
Boom, lowering.....	35 to 55 L/mn	7.6 to 12.9 gpm
Bucket, closing.....	140 to 150 L/mn	30.79 to 32.99 gpm
Bucket, opening.....	130 to 150 L/mn	28.59 to 32.99 gpm
Dipper, retracting.....	158 to 165 L/mn	34.75 to 38.29 gpm
Dipper, extension.....	150 to 165 L/mn	32.99 to 38.29 gpm
Travel, forward drive.....	166 to 170 L/mn	36.51 to 37.39 gpm
Travel, reverse drive.....	163 to 170 L/mn	35.85 to 37.39 gpm
Stabilizers and dozer blade: boom raising and lowering.....	45 to 55 L/mn	9.8 to 12.9 gpm
Stabilizers: shoe opening.....	18 to 22 L/mn	3.9 to 4.8 gpm
Stabilizers: shoe closing.....	45 to 55 L/mn	9.8 to 12.9 gpm
P4A excavator stabilizers: lowering.....	177 to 183 L/mn	38.93 to 40.25 gpm
P4A excavator stabilizers: raising.....	85 to 95 L/mn	18.69 to 20.89 gpm
Options.....	25 to 35 L/mn	5.49 to 7.6 gpm
Stabilizer shoe closing speed:.....		5 to 7 secondes
Thermostat controlled valve:		
Starts to close.....	40°C	106°F
Fully closed.....	50°C	126°F

## Tires

(Model 888P - 888PL - 888P2A - 888P2AL)

Four wheels Fitted.....18 - 19.5 XF  
 Eight wheels Fitted.....10 - 22.5 or 10.00 - 20

(Model 888P4A)

Eight wheels Fitted.....10 - 22.5 XM37

## Weights

Excavator with: monoblock boom, 2,10 m (83 inch) dipper and 760 L (1 cu.yd.) bucket:

Model 888P.....	13700 Kg	30140 lbs
Model 888PL.....	14300 Kg	31460 lbs
Model 888P2A.....	14500 Kg	31900 lbs
Model 888P2AL.....	15100 Kg	33220 lbs

Excavator with: adjustable boom, 2,10 m (83 inch) dipper and 760 L (1 cu.yd.) bucket:

Model 888P.....	14050 Kg	30910 lbs
Model 888PL.....	14650 Kg	32230 lbs
Model 888p2A.....	14850 Kg	32670 lbs
Model 888P2AL.....	15450 Kg	33990 lbs

Excavator with: offset boom, 2,10 m (83 inch) dipper and 760 L (1 cu.yd.) bucket:

Model 888P.....	14255 Kg	31361 lbs
Model 888PL.....	14855 Kg	32681 lbs
Model 888P2A.....	15055 Kg	33121 lbs
Model 888P2AL.....	15655 Kg	34441 lbs

Excavator with: articulated boom, 2,10 m (83 inch) dipper and 760 L (1 cu.yd.) bucket

Model 888P.....	14380 Kg	31636 lbs
Model 888PL.....	14980 Kg	32956 lbs
Model 888P2A.....	15180 Kg	33396 lbs
Model 888P2AL.....	15780 Kg	34716 lbs

Excavator with: boom, 3,90 m (154 inch) dipper and five-tine iron clamshell

Model 888P4A (only).....	15800 Kg	34760 lbs
--------------------------	----------	-----------

Excavator with: boom, 4,30 m (170 inch) dipper and five-tine iron clamshell

Model 888P4A (only).....	15830 Kg	34826 lbs
--------------------------	----------	-----------

## ATTACHMENTS

Models 888P, 888PL, 888P2AL

Boom (with dipper cylinder)

Monoblock.....	1085 Kg	2387 lbs
Adjustable.....	1435 Kg	3157 lbs
Offset.....	1640 Kg	3608 lbs
Articulated.....	1765 Kg	3883 lbs

Dipper (with yoke, rod and bucket cylinder)

1,60 m (63 inch).....	655 Kg	1441 lbs
2,10 m (83 inch).....	675 Kg	1485 lbs
2,70 m (106 inch).....	765 Kg	1683 lbs
3,10 m (122 inch).....	755 Kg	1661 lbs

## Weights (Continued)

### Model 888P4A.

Boom (with dipper cylinder).....	830 Kg	1826 lbs
3.90 m (154 inch) dipper.....	390 Kg	858 lbs
4.30 m (170 inch) dipper.....	420 Kg	924 lbs

### BUCKETS

Models 888P, 888PL, 888P2A, 888P2AL.

#### Trench bucket with ejector

Width	Weight	
0.35 m (14 inch).....	455 Kg	(1000 lbs)
0.45 m (18 inch).....	455 Kg	(1000 lbs)

#### General purpose bucket

Width	Weight	
0.60 m (24 inch).....	405 Kg	(890 lbs)
0.75 m (30 inch).....	460 Kg	(1010 lbs)
0.85 m (34 inch).....	485 Kg	(1070 lbs)
0.90 m (35 inch).....	495 Kg	(1090 lbs)
1.00 m (39 inch).....	530 Kg	(1165 lbs)
1.15 m (45 inch).....	580 Kg	(1275 lbs)
1.30 m (51 inch).....	630 Kg	(1386 lbs)

#### Ditchcleaning bucket with teeth

Width	Weight	
2.40 m (95 inch).....	520 Kg	(1145 lbs)
1.80 m (71 inch).....	550 Kg	(1210 lbs)

#### Ditchcleaning bucket fitted with reversible blade (smooth or serrated)

Width	Weight	
2.40 m (95 inch).....	575 Kg	(1265 lbs)
1.80 m (71 inch).....	590 Kg	(1300 lbs)

#### V - line bucket

Width	Weight	
0.50 m (20 inch).....	515 Kg	(1135 lbs)

### CLAMSHELLS

Models 888P, 888PL, 888P2A, 888P2AL.

#### Trench clamshell with ejector

Width	Weight	
0.45 m (18 inch).....	670 Kg	(1470 lbs)
0.65 m (26 inch).....	740 Kg	(1630 lbs)

#### Earthmoving clamshell

Width	Weight	
0.85 m (33 inch).....	760 Kg	(1670 lbs)
1.05 m (41 inch).....	810 Kg	(1780 lbs)

**Weights (Continued)****Boring clamshell**

Width	Capacity	Weight
1.20 m (47 inch).....	160 L (3/16 cu.yd).....	770 Kg (1690 lbs)

Models 888P - 888PL - 888P2A - 888P4A

**Rehandling clamshell**

Width	Weight
1.04 m (41 inch).....	810 Kg (1780 lbs)
1.34 m (53 inch).....	850 Kg (1870 lbs)
1.34 m (53 inch).....	925 Kg (2040 lbs)

**Beetroot clamshell**

Width	Weight
1.57 m (62 inch).....	1240 Kg (2730 lbs)
1.81 m (71 inch).....	1305 Kg (2780 lbs)

**Five-tine iron clamshell with detachable tine tips**

Opening diameter	Weight
1.90 m (75 inch).....	1100 Kg (2420 lbs)
1.90 m (75 inch).....	1200 Kg (2640 lbs)

**Five-tine iron clamshell**

Opening diameter	Weight
2.00 m (79 inch).....	1025 Kg (2260 lbs)

**Five-tine wood clamshell**

Opening diameter	Weight
2.50 m (98 inch).....	830 Kg (1830 lbs)

**Timber grab**

Width	Opening	Capacity	Weight
0,70 m (28 inch).....	2.75 m (110 inch).....	1.2 m <sup>2</sup> (13 sq.ft).....	990 Kg (2178 lbs)

## RUNNING-IN INSTRUCTIONS

### Engine Lubrication

Fill the engine crankcase with CD service classification oil that has the correct viscosity rating for the ambient air temperature. Refer to Engine Lubrication on page 11. Install new oil filters, after the engine has been rebuilt.

### Running-In Procedure For Rebuilt Engine

- STEP 1**      Disconnect the wire to the electric shut-off on the injection pump so that the engine will not start. Crank the engine for 30 seconds until there is oil pressure, then reconnect the wire.
- STEP 2**      Remove the air from the cooling system at the temperature sending unit
- STEP 3**      Run the engine at 1000 rpm minimum load for 5 minutes and check for oil leaks.
- STEP 4**      During the Running-In, continue to check the oil pressure, coolant level, and coolant temperature.

### Running-in Procedure For Rebuilt Engine (With A Dynamometer)

The following procedure must be followed when using a PTO dynamometer to Run-in the engine. The dynamometer will control the engine load at each speed and will remove stress on new parts during Running-In.

During the Running-In, continue to check the oil pressure, coolant level and coolant temperature.

STEP	TIME	ENGINE SPEED	DYNAMOMETER SCALE LOAD
1	5 Minutes	1000 rpm	50
2	5 Minutes	1100 rpm	1/2
2	5 Minutes	2200 rpm	Full

### Running-In Procedure For Rebuilt Engine (Without A Dynamometer)

STEP	TIME	ENGINE SPEED	LOAD
1	5 Minutes	1000 rpm	No Load
2	5 Minutes	1100 rpm	Light Load
3	5 Minutes	2200 rpm	Full

### Running-In Procedure

For the first 8 hours, operate the engine at full throttle maintaining a normal load. DO NOT "baby" the engine, but avoid converter or hydraulic stall. The engine must not be "lugged" below the rated engine rpm (Do not stall the engine more than 10 seconds).



## Engine Cooling System

Coolant Solution.....Ethylene Glycol

**IMPORTANT:** When using ethylene glycol coolant solutions, always have a minimum of 50% ethylene glycol coolant in the system. Do not put more than 50% ethylene glycol in the cooling system unless the ambient air temperature will be less than -36°C (-34°F). More than 50% decreases heat transfer and will cause the engine surface temperature to be higher than normal.

Thermostat.....Starts to open at 82°C (180°F)  
Fully open at 94°C (201°F)

Radiator Cap.....1.03 Bar (15 psi)

## Engine Lubrication

### Engine Oil Type

The SAE reference depends on climatic conditions. The degree of viscosity of the oil to use depends on the ambient temperature at the time of starting the engine.

#### ELF PERFORMANCE SUPER

Above 20°C (69°F).....SAE 30

Between -10°C and 20°C (14°F and 69°F).....SAE 20W20

Below -10°C (14°F).....SAE 10W

Above -10°C (14°F).....SAE 15W40

### Ambient air temperature ranges

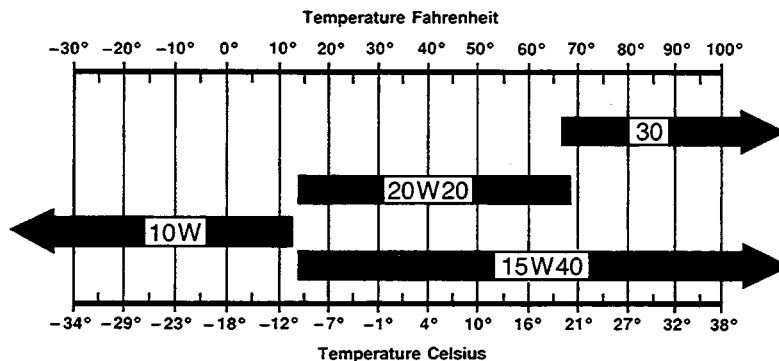

1000102A

## GENERAL ENGINE SPECIFICATIONS

### General

Make and Model.....	Jl Case, 6T-590	
Type.....	6 cylinders, turbocharged 4 stroke cycle	
Horsepower.....	145 at 2000 rpm	108 Kw at 2000 rpm
Firing Order.....	1, 5, 3, 6, 2, 4	
Bore and Stroke.....	102 mm x 120 mm	
Piston Displacement.....	5880 cm <sup>3</sup>	
Compression Ratio.....	17.5 to 1	
Valve Tappet Clearance		
Exhaust (Cold).....	0.508 mm	
Intake (Cold).....	0.254 mm	
Engine Speeds		
No Load Governed Speed.....	2140 to 2280 rpm	
Rated Engine Speed.....	2000 rpm	
Stall Speed, Full Load (minimum).....	2040 rpm	
Engine Idle Speed.....	900 rpm	

### Pistons and Connecting Rods

Rings per Piston.....	3
Number of Compression Rings.....	2
Number of Oil Rings (two pieces).....	1
Type of Pins.....	Full Float
Type of Bearings.....	Steel Back Leaded Bronze

### Main Bearings

Number of bearings.....	7
Type of Bearings.....	Replaceable

### Engine Lubricating System

Type of System.....	Pressure and Spray Lubrication	
Oil Pressure (when engine warm and operating at rated speed).....	2.07 to 3.45 bar	40 to 50 psi
Oil Pump.....	Rotor Type	
Oil Filter.....	Full Flow Turn-on Type	
Oil Capacity		
(with filter change).....	15.4 litres	16 US quarts
(without filter change).....	14.4 litres	15 US quarts

## Fuel System

Fuel Injection Pump.....	Bosch	
Pump Timing.....	Top Dead Center	
Fuel Injectors.....	Bosch 17 mm	
Opening Pressure (New).....	231 to 253 bar	3350 to 3670 psi
Opening Pressure (Used).....	221 to 250 bar	3200 to 3625 psi
Maximum Pressure Difference.....	10.34 bar	150 psi
Number of Orifices.....	4	
Spray Orifice Size.....	0.29 mm	
Governor.....	Variable Speed, Part of the Injection Pump	
First Stage Fuel Filter.....	Turn-on Type	
Second Stage Fuel Filter.....	Turn-on Type	
Lift Pump.....	0.34 to 0.48 bar	5 to 7 psi

## DETAILED ENGINE SPECIFICATIONS

### Cylinder Block

Type.....	Non-Sleeved
Material.....	Cast Iron
ID of Cylinder.....	102.00 to 102.04 mm
Maximum Service Limit.....	102.116 mm
Cylinder Out of Round (Maximum).....	0.038 mm
Cylinder Taper (Maximum).....	0.076 mm
0.5 mm Oversize Piston	
Machine Cylinder Bore to.....	102.40 to 102.44 mm
Hone Cylinder Bore to.....	102.50 to 102.54 mm
1.00 mm Oversize Piston	
Machine Cylinder Bore to.....	102.900 to 102.960 mm
Hone Cylinder Bore to.....	103.00 to 103.04 mm

### Service Cylinder Sleeves

Type.....	Dry, Can Be Replaced
Material.....	Cast Iron
Machine Cylinder Block Bore to.....	104.485 to 104.515 mm
Installation.....	Press Fit
Hone Cylinder Bore to.....	102.00 to 102.10 mm

### Pistons

Type.....	Cam Ground
Material.....	Aluminium alloy
OD at 12 mm From the Bottom, 90 Degrees From Piston Pin	
Standard Size Piston.....	101.873 to 101.887 mm
Minimum Service Limit.....	101.823 mm
0.5 Oversize Piston.....	102.373 to 102.387 mm
Minimum Service Limit.....	102.323 mm
1.00 Oversize Piston.....	102.873 to 102.887 mm
Minimum Service Limit.....	102.823 mm
ID of Piston Pin Bore.....	40.006 to 40.012 mm
Maximum Service Limit.....	40.025 mm
Width of 1st Ring Groove (Top).....	2.465 to 2.485 mm
Width of 2nd Ring Groove (Intermediate).....	2.425 to 2.445 mm
Width of 3rd Ring Groove (Oil Ring).....	4.040 to 4.060 mm
Protrusion Above Cylinder Block (Maximum).....	0.660 mm

### Piston Pins

Type.....	Full Float
OD of Pin.....	39.997 to 40.003 mm
Minimum Service Limit.....	39.990 mm

## Piston Rings

N°1 Compression.....	Key Stone Type (Barrel Face)
End Gap in 102.02 ID.....	0.40 to 0.70 mm
Maximum Service Limit.....	0.806 mm
Side Clearance.....	0.075 to 0.120 mm
Maximum Service Limit.....	0.15 mm
N°2 Compression.....	Rectangular Type (Taper Face)
End Gap in 102.02 ID.....	0.25 to 0.55 mm
Maximum Service Limit.....	0.806 mm
Side Clearance.....	0.075 to 0.120 mm
Maximum Service Limit.....	0.15 mm
N°3 Oil Control Rings.....	Two pieces
End Gap in 102.02 ID.....	0.25 to 0.55 mm
Maximum Service Limit.....	0.806 mm
Side Clearance.....	0.130 mm

## Cylinder Head

Warpage (Maximum).....	0.20 mm
------------------------	---------

## Lifters

Material.....	Hardened Iron
OD of Lifter.....	15.961 to 15.977 mm
Minimum Service Limit.....	15.960 mm
Bore Diameter in Block.....	16.000 to 16.030 mm
Maximum Service Limit.....	16.055 mm

## Connecting Rods

Bushing.....	Steel Backed Leaded Bronze
Bushing ID Installed (Ream to Size).....	40.053 to 40.067 mm
Maximum Service Limit.....	40.092 mm
Bearing Liners.....	Replaceable
Journal ID Without Bearing Liners.....	72.987 to 73.013 mm
Bearing Oil Clearance.....	0.038 to 0.116 mm
Maximum Service Limit.....	0.129 mm
Side Clearance.....	0.100 to 0.300 mm
Maximum Service Limit.....	0.330 mm
Connecting Rod Bend (Maximum)	
Without Bushing.....	0.200 mm
With Bushing.....	0.150 mm
Connecting Rod Twist (Maximum)	
Without Bushing.....	0.500 mm
With Bushing.....	0.300 mm

## Crankshaft

Type.....	Hardened Steel, Balanced
Main Bearing Liners.....	Replaceable
Crankshaft End Clearance.....	0.137 to 0.264 mm
Center Main Bearing Thrust Surface Thickness.....	2.50 mm
<b>Connecting Rod Journal</b>	
OD, Standard.....	68.987 to 69.013 mm
Maximum Service Limit.....	68.962 mm
0.25 mm OD Undersize, Grind to.....	68.737 to 68.763 mm
Maximum Service Limit.....	68.712 mm
0.50 mm OD Undersize, Grind to.....	68.487 to 68.513 mm
Maximum Service Limit.....	68.462 mm
0.75 mm OD Undersize, Grind to.....	68.237 to 68.263 mm
Maximum Service Limit.....	68.212 mm
1.00 mm OD Undersize, Grind to.....	67.987 to 68.013 mm
Maximum Service Limit.....	67.962 mm
Connecting Rod Journal Maximum Taper.....	0.013 mm
Journals Out of Round Maximum.....	0.050 mm
Undersize Main Bearing Liners For Service.....	0.25, 0.50, 0.75 and 1.00 mm
Main Bearing Oil Clearance.....	0.041 to 0.119 mm
Maximum Service Limit.....	0.140 mm
<b>Main Bearing Journal</b>	
OD, Standard.....	82.987 to 83.013 mm
Maximum Service Limit.....	82.962 mm
0.25 mm OD Undersize, Grind to.....	82.737 to 82.763 mm
Maximum Service Limit.....	82.712 mm
0.50 mm OD Undersize, Grind to.....	82.487 to 82.513 mm
Maximum Service Limit.....	82.462 mm
0.75 mm OD Undersize, Grind to.....	82.237 to 82.263 mm
Maximum Service Limit.....	82.212 mm
1.00 mm OD Undersize, Grind to.....	81.987 to 82.013 mm
Maximum Service Limit.....	81.962 mm
Main Bearing Journal Bore ID No Liners.....	87.982 to 88.018 mm
Maximum Service Limit.....	88.031 mm
<b>Main Journal Width</b>	
1st, 2nd, 3rd, 5th and 6th.....	37.424 to 37.576 mm
4th.....	37.475 to 37.525 mm
Connecting Rod Journals Width.....	38.950 to 39.050 mm

## Camshaft

Type.....	Hardened Iron
Bushing (Front Only).....	1, Replaceable
Bushing Lubrication:	
Front Bushing.....	Pressure Lubricated
Intermediate.....	Pressure Lubricated
Rear.....	Pressure Lubricated
Oil Clearance.....	0.076 to 0.152 mm
ID of No. 1 Bushing (Installed).....	54.107 to 54.133 mm
Maximum Service Limit.....	54.146 mm
ID of No. 1 Oversize (57.36 to 57.40 mm OD) Service Bushing.....	54.107 to 54.133 mm
Maximum Service Limit.....	54.146 mm
ID of No. 2, 3, 4, 5 and 6 Service Bushing.....	54.107 to 54.133 mm
Maximum Service Limit.....	54.146 mm
Width of No. 1 Bushing.....	25.15 to 25.65 mm
Width of No. 2, 3, 4, 5 and 6 Service Bushing.....	17.75 to 18.25 mm
Camshaft Bushing Journal OD.....	53.987 to 54.013 mm
Minimum Serviceable Limit.....	53.962 mm
Camshaft Bore Diameter in Block	
No. 1 Bushing.....	57.222 to 57.258 mm
No. 1 Oversize Bushing, Machine to.....	57.722 to 57.758 mm
No. 2, 3, 4, 5 and 6 Less Bushings.....	54.107 to 54.133 mm
No. 2, 3, 4, 5 and 6 Oversize for Bushings, Machine to.....	57.222 to 57.258 mm
Camshaft Thrust Thickness.....	9.42 to 9.58 mm
Minimum Service Limit.....	9.34 mm
Camshaft Thrust Clearance.....	0.130 to 0.340 mm
Maximum Service Limit.....	0.470 mm

## Turbocharger

Horizontal Travel of Turbine Shaft.....	0.10 to 0.16 mm
---	-----------------

## Gear Train

### Backlash:

Crankshaft Gear to Camshaft Gear.....	0.08 to 0.33 mm
Crankshaft Gear to Idler Gear.....	0.08 to 0.33 mm
Camshaft to Fuel Pump Gear.....	0.08 to 0.33 mm
Idler Gear to Oil Pump.....	0.08 to 0.33 mm
Camshaft to Auxiliary.....	0.08 to 0.33 mm
Maximum Service Limit (All Gears).....	0.45 mm

## Rocker Arm Assembly

OD of Shaft.....	18.963 to 18.975 mm
Minimum Service Limit.....	18.938 mm
ID of Arm Bore.....	19.000 to 19.026 mm
Maximum Service Limit.....	19.051 mm
Lubrication.....	Pressure From Oil Gallery

## Intake Valves

Tappet Clearance (Cold).....	0.254 mm
Face Angle.....	29 Degrees
Face Run-Out.....	0.038 mm
Valve Head Edge Thickness, Minimum.....	1.50 mm
Length.....	128.84 to 129.46 mm
OD of Stem.....	7.960 to 7.980 mm
Minimum Service Limit.....	7.940 mm
OD of Head.....	44.870 to 45.130 mm
Seat Angle.....	30 Degrees
Seat Contact Width.....	1.32 to 1.92 mm
Seat Run-Out.....	0.10 mm
Insert Height.....	6.84 to 6.96 mm
OD of Insert.....	47.063 to 47.089 mm
ID of Insert.....	Tapered
Valve Recession Below Head Surface.....	0.99 to 1.52 mm
Maximum Service Limit.....	1.52 mm
ID of Valve Guide Bore.....	8.019 to 8.039 mm
Maximum Service Limit.....	8.089 mm

## Exhaust Valves

Tappet Clearance (Cold).....	0.508 mm
Face Angle.....	44 Degrees
Face Run-Out.....	0.038 mm
Valve Head Edge Thickness, Minimum.....	1.50 mm
OD of Head.....	41.870 to 42.130 mm
OD of Stem.....	7.960 to 7.980 mm
Minimum Service Limit.....	7.940 mm
Length.....	128.74 to 129.36 mm
Insert Seat Angle.....	45 Degrees
Seat Contact Width.....	1.47 to 2.07 mm
Seat Run-Out.....	0.10 mm
Insert Height.....	6.65 to 6.77 mm
OD of Insert.....	43.713 to 43.739 mm
ID of Insert.....	Tapered
Valve Recession Below Head Surface.....	0.99 to 1.52 mm
Maximum Service Limit.....	1.52 mm
ID of Valve Guide Bore.....	8.019 to 8.039 mm
Maximum Service Limit.....	8.089 mm

## Valve Springs

Free Length.....	55.63 mm
Total Coils.....	7.25 mm
Wire Diameter.....	4.830 to 4.930 mm
Compressed to 38.53 mm.....	(Valve Open) 785 to 839 N
Maximum Service Limit.....	765 N
Compressed to 49.25 mm.....	(Valve Closed) 285 to 321 N
Minimum Service Limit.....	270 N



## SPECIAL TORQUES

Aftercooler Bolts.....	24 Nm	18 lb ft
Air Crossover Elbow to Intake Intercooler.....	24 Nm	18 lb ft
Alternator Bracket Bolts (Lower).....	24 Nm	18 lb ft
Alternator Bracket Bolts (Upper).....	24 Nm	18 lb ft
Alternator Retaining Bolt.....	24 Nm	18 lb ft
Belt Tensioner Bracket Bolts.....	24 Nm	18 lb ft
Belt Tensioner Retaining Bolt.....	43 Nm	32 lb ft
Camshaft Retaining Bolts.....	24 Nm	18 lb ft
Center Housing to Back Plate Bolts.....	6 Nm	4.5 lb ft
Compressor Housing Bolts.....	6 Nm	4.5 lb ft
Compressor Lock Nut.....	14 Nm	10.5 lb ft
Connecting Rod Bolts (Lubricate Threads With Engine Oil).....	100 Nm	74 lb ft
Coolant Inlet Bolts.....	43 Nm	32 lb ft
Crankshaft Dampener Pulley.....	137 Nm	101 lb ft
Cylinder Head Bolts.....	126 Nm	93 lb ft
Engine Lift Bracket Bolts (Rear).....	77 Nm	57 lb ft
Exhaust Manifold Bolts.....	43 Nm	32 lb ft
Fan Pulley Bracket Bolts.....	24 Nm	18 lb ft
Fan Pulley Bolts (Grade 8.8).....	24 Nm	18 lb ft
Fan Pulley Bolts (Grade 10.9).....	34 Nm	25 lb ft
Flywheel Housing Bolts.....	60 Nm	45 lb ft
Flywheel Housing Cover Bolts.....	24 Nm	18 lb ft
Flywheel Retaining Bolts.....	137 Nm	101 lb ft
Front Cover Bolts.....	24 Nm	18 lb ft
Front Housing Bolts.....	24 Nm	18 lb ft

Fuel Air Removal Bolt.....	6 Nm	4.5 lb ft
Fuel Filter Inlet Bolt.....	32 Nm	24 lb ft
Fuel Filter Inlet Bolt.....	32 Nm	24 lb ft
Fuel Line Fitting (High Pressure).....	24 Nm	18 lb ft
Fuel Line Fitting (Low Pressure).....	24 Nm	18 lb ft
Fuel Pump Plug with Bronze Washer.....	23 Nm	17 lb ft
Fuel Shutoff Solenoid.....	15 Nm	11 lb ft
Injection Pump Drive Gear Nut.....	65 Nm	48 lb ft
Injection Pump Lock Bolt.....	30 Nm	22 lb ft
Injection Pump Retaining Nuts.....	24 Nm	18 lb ft
Injection Pump Bracket Bolts.....	24 Nm	18 lb ft
Injector Leak off Bolt.....	15 Nm	11 lb ft
Injector Retaining Nut.....	60 Nm	45 lb ft
Intake Manifold Bolts.....	24 Nm	18 lb ft
Intake Manifold Plug.....	125 Nm	92 lb ft
Intercooler Bolts.....	24 Nm	18 lb ft
Lifter Cover Bolts.....	24 Nm	18 lb ft
Main Bearing Bolts (Lubricate The Theads With Engine Oil).....	175 Nm	129 lb ft
Oil Fill Tube Bolts.....	43 Nm	32 lb ft
Oil Filter Housing Bolts.....	24 Nm	18 lb ft
Oil inlet Tube Bolts.....	24 Nm	18 lb ft
Oil Inlet Tube Brace.....	24 Nm	18 lb ft
Oil Pan Drain Plug.....	75 Nm	55 lb ft
Oil Pan Heater Plug.....	122 Nm	90 lb ft
Oil Pan Retaining Bolts.....	24 Nm	18 lb ft
Oil Pump Retaining Bolts.....	24 Nm	18 lb ft
Rear Seal Retaining Bolts.....	9 Nm	7 lb ft
Rocker Arm Bolts.....	24 Nm	18 lb ft

Starter Retaining Bolts.....	43 Nm	32 lb ft
Tachometer Drive Retaining Bolts.....	3 Nm	2 lb ft
Thermostat Housing Bolts.....	24 Nm	18 lb ft
Thrust Bearing Screws (Torx Head).....	5 Nm	4 lb ft
Timing Pin Retaining Bolts.....	5 Nm	4 lb ft
Turbine Housing Bolts.....	11 Nm	8.5 lb ft
Turbocharger Drain Tube Bolts.....	24 Nm	18 lb ft
Turbocharger Mounting Bolts.....	32 Nm	24 lb ft
Turbocharger Oil Supply (Both Ends).....	17 Nm	13 lb ft
Valve Cover Bolts.....	24 Nm	18 lb ft
Water Pump Mounting Bolts.....	24 Nm	18 lb ft

## GENERAL DIMENSIONS (Model 888P)

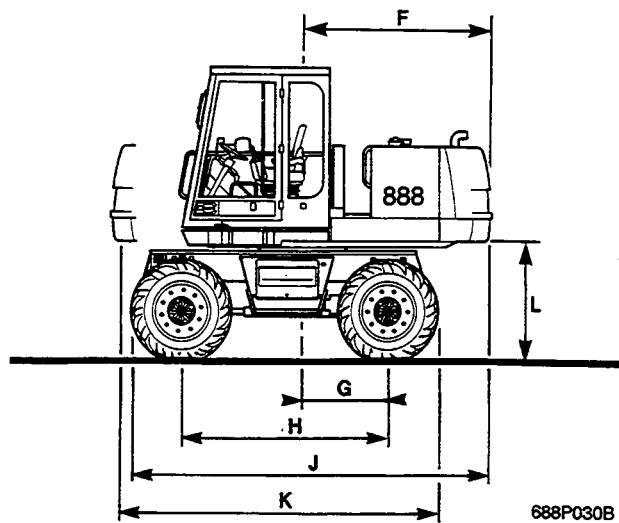
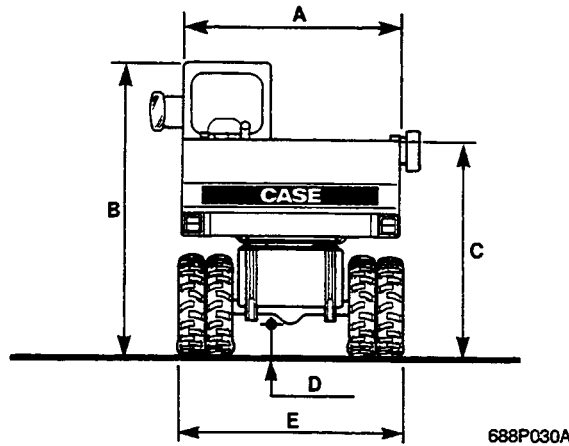

### SPECIFICATIONS

A.....	2.44 m	8 ft 0 in
B.....	3.16 m	10 ft 4 in
C.....	2.44 m	8 ft 0 in
D.....	0.31 m	1 ft 0 in
E.....	2.46 m	8 ft 1 in
F.....	Radius 2.40 m	7 ft 9 in
G.....	1.03 m	3 ft 4 in
H.....	2.50 m	8 ft 2 in
J.....	4.38 m	14 ft 4 in
K.....	3.97 m	13 ft 1 in
L.....	1.32 m	4 ft 3 in

## GENERAL DIMENSIONS (Model 888PL)

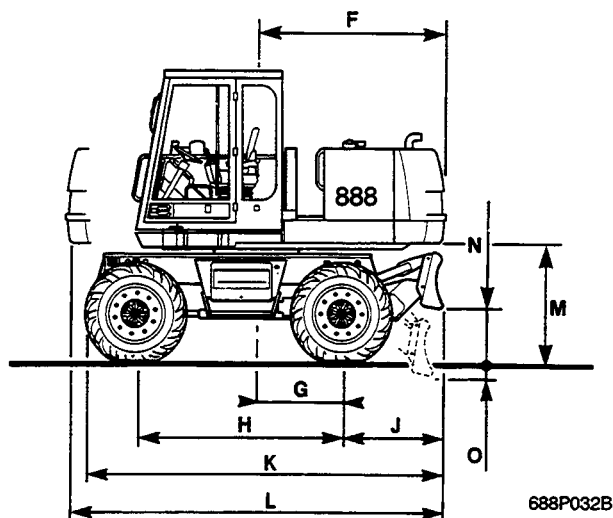
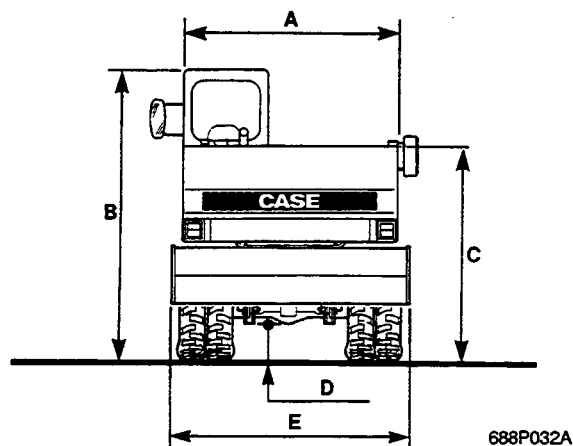

### SPECIFICATIONS

A.....	2.44 m	8 ft 0 in
B.....	3.16 m	10 ft 4 in
C.....	2.44 m	8 ft 0 in
D.....	0.31 m	1 ft 0 in
E.....	2.48 m	8 ft 1 in
F.....	Radius 2.40 m	7 ft 9 in
G.....	1.03 m	3 ft 4 in
H.....	2.50 m	8 ft 2 in
J.....	1.13 m	3 ft 7 in
K.....	4.38 m	14 ft 4 in
L.....	4.56 m	15 ft 0 in
M.....	1.32 m	4 ft 3 in
N.....	0.59 m	1 ft 9 in
O.....	0.17 m	0 ft 5 in

## GENERAL DIMENSIONS (Model 888P2A)

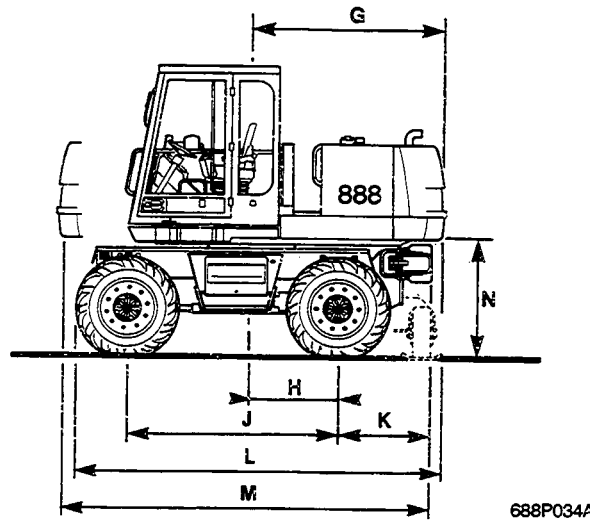
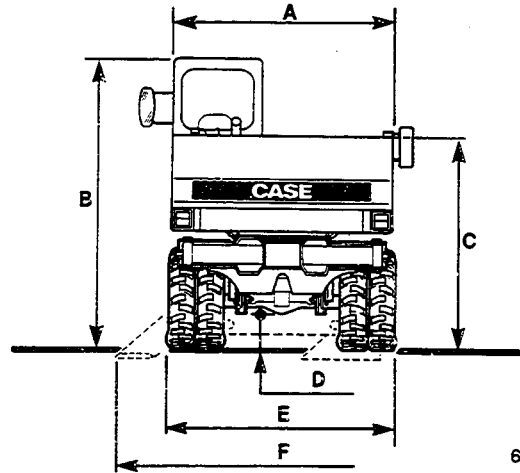

### SPECIFICATIONS

A.....	2.44 m	8 ft 0 in
B.....	3.16 m	10 ft 4 in
C.....	2.44 m	8 ft 0 in
D.....	0.31 m	1 ft 0 in
E.....	2.46 m	8 ft 1 in
F.....	3.58 m	11 ft 8 in
G.....	Radius 2.40 m	7 ft 9 in
H.....	1.03 m	3 ft 4 in
J.....	2.50 m	8 ft 2 in
K.....	1.05 m	3 ft 4 in
L.....	4.38 m	14 ft 4 in
M.....	4.48 m	14 ft 7 in
N.....	1.32 m	4 ft 3 in

## GENERAL DIMENSIONS (Model 888P2AL)

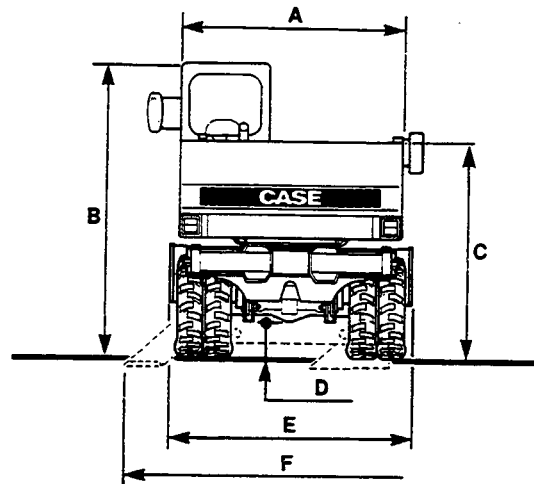

688P036A

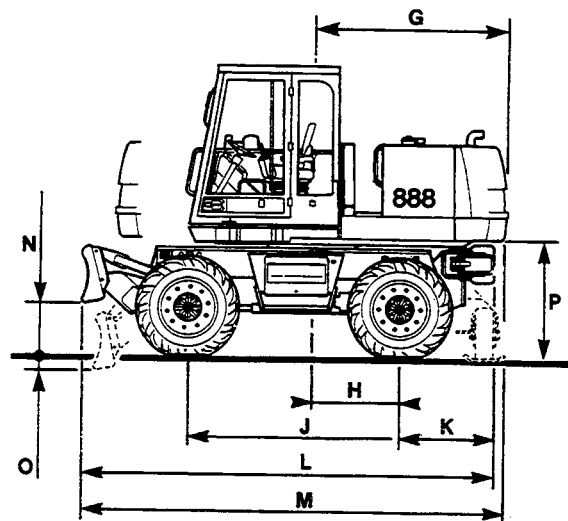

688P036B

### SPECIFICATIONS

A.....	2.44 m	8 ft 0 in
B.....	3.16 m	10 ft 4 in
C.....	2.44 m	8 ft 0 in
D.....	0.31 m	1 ft 0 in
E.....	2.48 m	8 ft 1 in
F.....	3.58 m	11 ft 7 in
G.....	Radius 2.40 m	7 ft 9 in
H.....	1.03 m	3 ft 4 in
J.....	2.50 m	8 ft 2 in
K.....	1.05 m	3 ft 4 in
L.....	4.69 m	15 ft 3 in
M.....	5.01 m	16 ft 4 in
N.....	0.59 m	1 ft 9 in
O.....	0.17 m	0 ft 5 in
P.....	1.32 m	4 ft 3 in

### GENERAL DIMENSIONS (Model 888P4A)

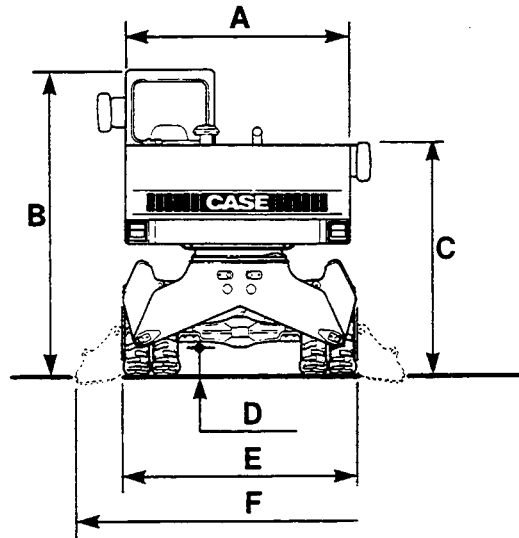

OM10001

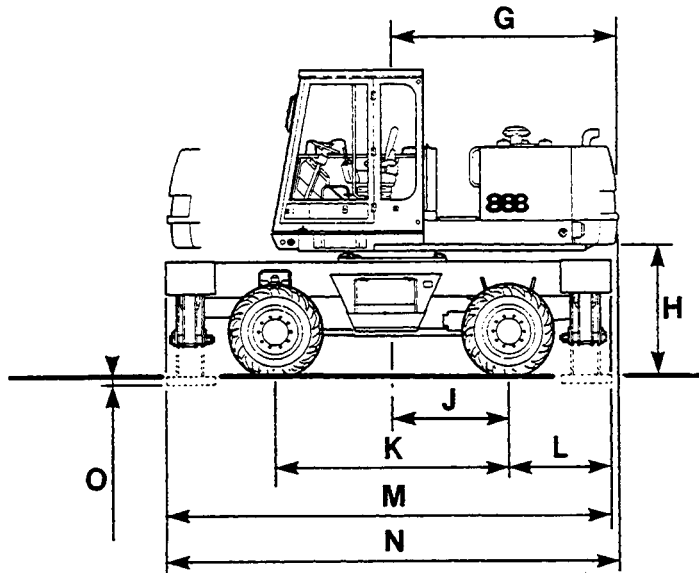

OM10002

### SPECIFICATIONS

A.....	2.44 m	8 ft 0 in
B.....	3.30 m	10 ft 8 in
C.....	2.45 m	8 ft 0 in
D.....	0.31 m	1 ft 0 in
E.....	2.48 m	8 ft 1 in
F.....	3.40 m	11 ft 1 in
G.....	Radius 2.40 m	7 ft 9 in
H.....	1.42 m	4 ft 6 in
J.....	1.25 m	4 ft 1 in
K.....	2.50 m	8 ft 2 in
L.....	1.12 m	3 ft 7 in
M.....	4.83 m	15 ft 8 in
N.....	4.85 m	15 ft 9 in
O.....	0.08 m	0 ft 3 in



## TRANSPORT DIMENSIONS

### Models 888P, 888PL and 888P2A with monoblock back-hoe attachment

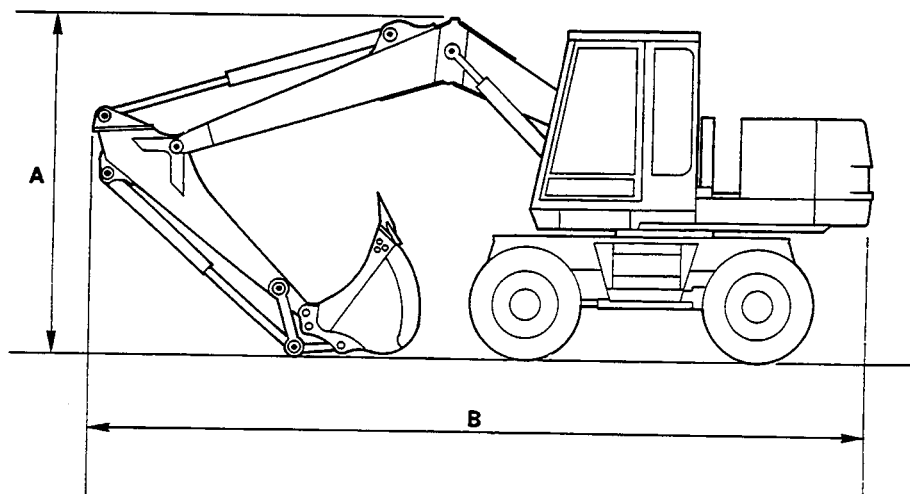

688P038

**CAUTION:** Height from ground to cab, see machine overall measurements.

Monoblock boom with 1.60 m (63 inch) dipper and 760 L (1 cu.yd) bucket:

A.....	3.10 m	10 ft 1 in
B.....	8.90 m	29 ft 2 in

Monoblock boom with 2.10 m (83 inch) dipper and 760 L (1 cu.yd) bucket:

A.....	3.00 m	9 ft 8 in
B.....	8.60 m	28 ft 2 in

Monoblock boom with 2.70 m (106 inch) dipper and 760 L (1 cu.yd) bucket:

A.....	3.30 m	10 ft 8 in
B.....	8.70 m	28 ft 5 in

Adjustable boom with 1.60 m (63 inch) dipper and 760 L (1 cu.yd) bucket:

A.....	3.90 m	12 ft 8 in
B.....	7.00 m	23 ft 0 in

Adjustable boom with 2.10 m (83 inch) dipper and 760 L (1 cu.yd) bucket:

A.....	3.95 m	13 ft 0 in
B.....	6.85 m	22 ft 5 in

Adjustable boom with 2.70 m (106 inch) dipper and 760 L (1 cu.yd) bucket:

A.....	4.00 m	13 ft 1 in
B.....	6.50 m	21 ft 3 in

Offset boom with 1.60 m (63 inch) dipper and 760 L (1 cu.yd) bucket:

A.....	3.20 m	10 ft 5 in
B.....	9.00 m	29 ft 5 in

Offset boom with 2.10 m (83 inch) dipper and 760 L (1 cu.yd) bucket:

A.....	3.30 m	10 ft 8 in
B.....	8.70 m	28 ft 5 in

### Transport Dimensions (continued)

Articulated boom with 1.60 m (63 inch) dipper and 760 L (1 cu.yd) bucket:

A.....	3.35 m	11 ft 0 in
B.....	8.70 m	28 ft 5 in

Articulated boom with 2.10 m (83 inch) dipper and 760 L (1 cu.yd) bucket:

A.....	3.35 m	11 ft 0 in
B.....	8.50 m	27 ft 9 in

Articulated boom with 2.70 m (106 inch) dipper and 760 L (1 cu.yd) bucket:

A.....	3.45 m	11 ft 3 in
B.....	8.50 m	27 ft 9 in

## Model 888P2AL, with monoblock back-hoe attachment

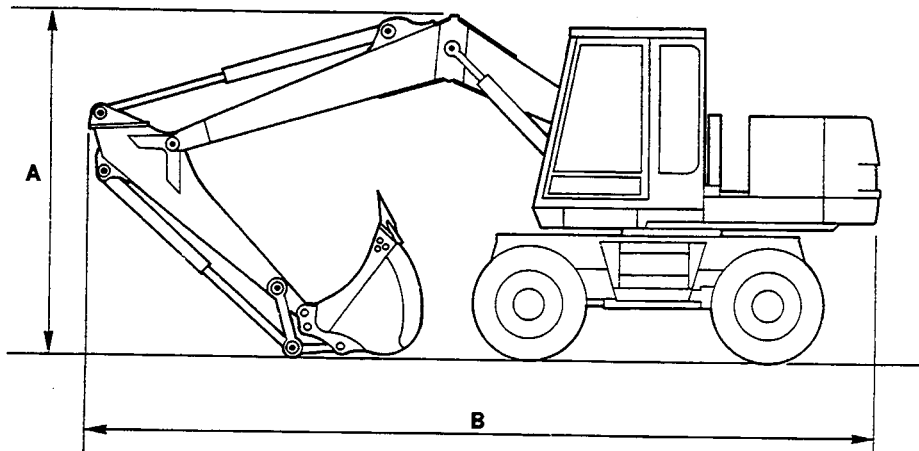

688P038

**CAUTION:** Height from ground to cab, see machine overall measurements.

Monoblock boom with 1.60 m (63 inch) dipper and 760 L (1 cu.yd) bucket:

A.....	3.10 m	10 ft 2 in
B.....	8.90 m	29 ft 2 in

Monoblock boom with 2.10 m (83 inch) dipper and 760 L (1 cu.yd) bucket:

A.....	3.00 m	9 ft 8 in
B.....	8.60 m	28 ft 2 in

Monoblock boom with 2.70 m (106 inch) dipper and 760 L (1 cu.yd) bucket:

A.....	3.50 m	11 ft 5 in
B.....	8.60 m	28 ft 2 in

Adjustable boom with 1.60 m (63 inch) dipper and 760 L (1 cu.yd) bucket:

A.....	3.90 m	12 ft 8 in
B.....	6.70 m	22 ft 0 in

Adjustable boom with 2.10 m (83 inch) dipper and 760 L (1 cu.yd) bucket:

A.....	4.00 m	13 ft 1 in
B.....	6.65 m	21 ft 8 in

Adjustable boom with 2.70 m (106 inch) dipper and 760 L (1 cu.yd) bucket:

A.....	4.20 m	13 ft 8 in
B.....	6.70 m	22 ft 0 in

Offset boom with 1.60 m (63 inch) dipper and 760 L (1 cu.yd) bucket:

A.....	3.20 m	10 ft 5 in
B.....	9.00 m	29 ft 5 in

Offset boom with 2.10 m (83 inch) dipper and 760 L (1 cu.yd) bucket:

A.....	3.30 m	10 ft 8 in
B.....	8.70 m	28 ft 5 in

## Transport Dimensions (continued)

Articulated boom with 1.60 m (63 inch) dipper and 760 L (1 cu.yd) bucket:

A.....	3.35 m	11 ft 0 in
B.....	8.70 m	28 ft 5 in

Articulated boom with 2.10 m (83 inch) dipper and 760 L (1 cu.yd) bucket:

A.....	3.35 m	11 ft 0 in
B.....	8.50 m	27 ft 9 in

Articulated boom with 2.70 m (106 inch) dipper and 760 L (1 cu.yd) bucket:

A.....	3.50 m	11 ft 5 in
B.....	8.45 m	27 ft 7 in

### Model 888P4A

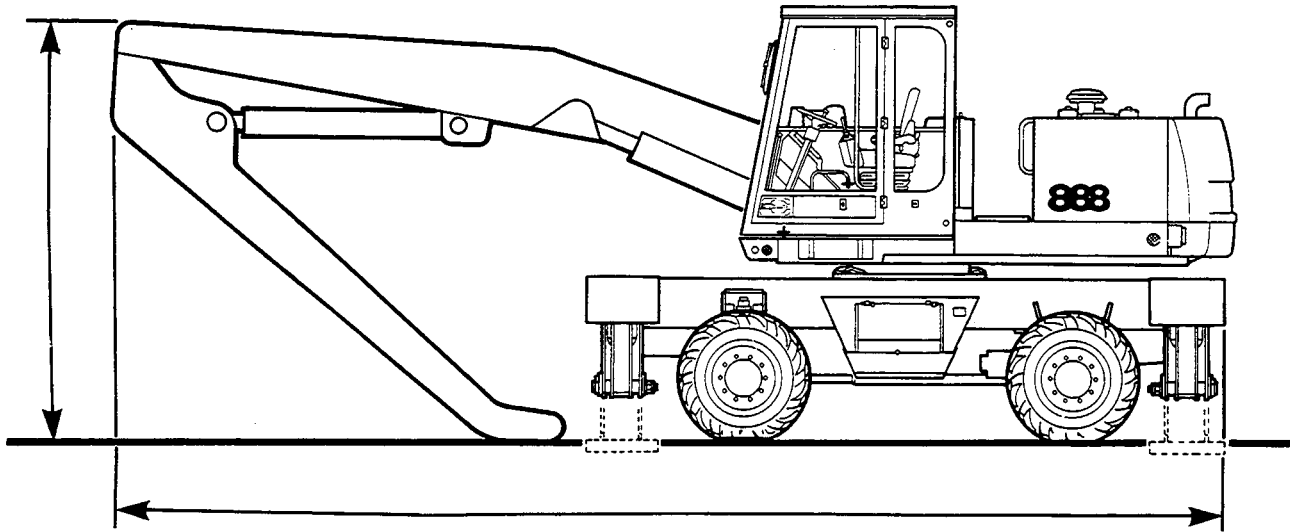

OM10003

Boom and 3.90 m (154 inch) dipper:

A.....	2.70 m	8 ft 8 in
B.....	8.90 m	29 ft 2 in

Boom and 4.30 m (170 inch) dipper:

A.....	2.80 m	9 ft 2 in
B.....	8.70 m	28 ft 5 in



**Section**  
**1002**  
**SPECIFICATIONS**

1002

For 888P Excavators  
(888P Serial Number: 6201 and after)  
(888P4A Serial Number: 7701 and after)

## TABLE OF CONTENTS

MODEL AND SERIAL NUMBERS.....	3
<b>GENERAL SPECIFICATIONS</b>	
Capacities.....	4
Drive Speed.....	4
Electrical System.....	4
Fluids and Lubricants.....	5
Hydraulic System.....	5
Tires.....	7
Weights.....	7
<b>ENGINE SPECIFICATIONS</b>	
<b>IMPORTANT:</b> <i>This engine was made using the metric measurement system. All measurements and checks must be made with metric tools to make sure of an accurate reading when inspecting parts.</i>	
Running-In Instructions.....	10
Engine Cooling System.....	11
Engine Lubrication.....	11
General Engine Specifications	
General.....	12
Pistons and Connecting Rods.....	12
Main Bearings.....	12
Engine Lubricating System.....	12
Fuel System.....	13
Detailed Engine Specifications	
Cylinder Block.....	14
Service Cylinder Sleeves.....	14
Pistons.....	14
Piston Pins.....	14
Piston Rings.....	15
Cylinder Head.....	15
Lifters.....	15
Connecting Rods.....	15
Crankshaft.....	16
Camshaft.....	17
Turbocharger.....	17
Gear Train.....	17
Rocker Arm Assembly.....	17
Intake Valves.....	18
Exhaust Valves.....	18
Valve Springs.....	18
Special Torques.....	19
GENERAL DIMENSIONS.....	22
TRANSPORT DIMENSIONS.....	27



## MODEL AND SERIAL NUMBERS

When ordering parts or when requesting information or assistance, always give the identification numbers of your machine.

Write the model and serial numbers of your machine on the lines below.

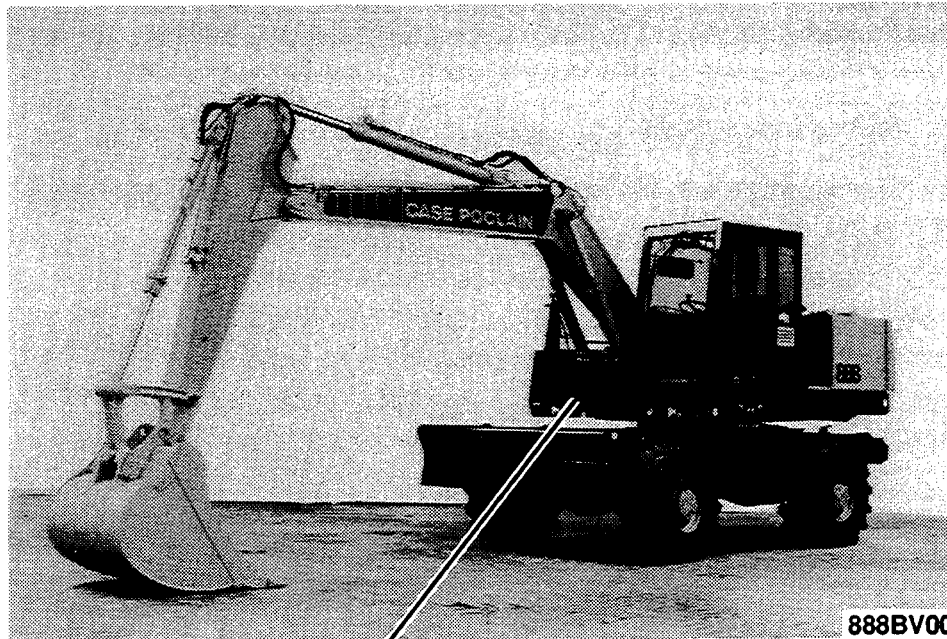

888BV00

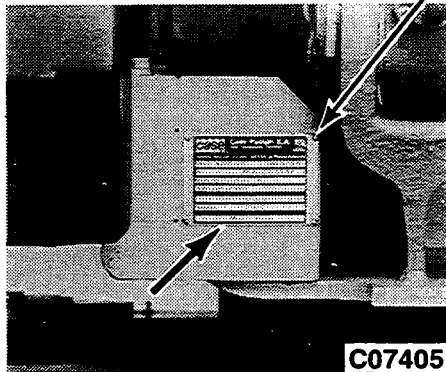

C07405

Machine Model Number

Machine Serial Number

Engine Serial Number

High Pressure Pump Serial Number

Low Pressure Pump Serial Number

## GENERAL SPECIFICATIONS

### Capacities

Engine Oil Capacity (with filter change).....	15.4 litres	3.38 gallons
Engine Cooling System (with cab heater).....	19.2 litres	4.22 gallons
Fuel Tank.....	247 litres	54.34 gallons
Hydraulic Oil Reservoir Capacity.....	130 litres	28.6 gallons
Total Hydraulic System Capacity.....	205 litres	45.1 gallons
Swing Reduction Gear Capacity.....	3.5 litres	6.16 pints
Front Axle Capacity.....	16 litres	3.52 gallons
Rear Axle Capacity.....	20 litres	4.4 gallons
Axle Reduction Gear Housing Capacity (each).....	2.7 litres	4.7 pints

**NOTE:** These capacities are only a guide to the quantities. Always use the dipstick, sight gauge or level plug to make sure that fluid levels are correct.

### Drive speed

Drive speed.....0 to 4.7 m.p.h. Work-site range  
0 to 15.6 m.p.h road range

### Electrical System

Type of System.....24 volts, negative ground

#### Alternator

Manufacturer.....Bosch  
Output.....28 volts at 45 amperes  
Resistance of rotor winding.....9.0 ohms  
Resistance of stator winding.....0.22 ohms  
Minimum brush length.....14 mm (0.55 inch)

#### Batteries

Number of batteries required.....2  
Voltage of each battery.....12 volts  
Reserve capacity.....160 minutes  
Cold cranking capacity at -17°C (0°F).....800 amperes  
Load for capacity (load) test.....400 amperes

#### Starter Motor

Manufacturer.....Bosch  
No load test at 27°C (80°F)  
Volts.....23 volts  
Current draw.....85 amperes maximum  
Armature speed.....7000 rpm minimum  
Brush length.....8.5 mm (0.3125 inch) minimum  
Armature run-out.....0.03 mm (0.001 inch) maximum  
Commutator diameter.....42.5 mm (1.74 inch) minimum  
Armature end play.....0.05 to 0.4 mm (0.002 to 0.15 inch)

This as a preview PDF file from [best-manuals.com](http://best-manuals.com)



Download full PDF manual at [best-manuals.com](http://best-manuals.com)