

85 I FX
85 I FX Plus
Backhoe Loader

SERVICE MANUAL

Part number 91715732
English
July 2021

© 2021 Case New Holland Construction Equipment (India) Pvt. Ltd. All rights reserved.

CASE
CONSTRUCTION



SERVICE MANUAL

**851FX Plus
851FX**

Contents

INTRODUCTION

Engine.....	10
[10.001] Engine and crankcase	10.1
[10.114] Pump drives	10.2
[10.202] Air cleaners and lines	10.3
[10.254] Intake and exhaust manifolds and muffler	10.4
[10.500] Selective Catalytic Reduction (SCR) exhaust treatment	10.5
[10.400] Engine cooling system	10.6
[10.310] Aftercooler.....	10.7
Power coupling.....	19
[19.100] Drive shaft.....	19.1
Transmission.....	21
[21.100] Mechanical transmission hydraulic components.....	21.1
[21.112] Power shuttle transmission.....	21.2
[21.134] Power shuttle transmission external controls	21.3
[21.154] Power shuttle transmission internal components	21.4
[21.700] Torque converter	21.5
Front axle system	25
[25.100] Powered front axle	25.1
[25.102] Front bevel gear set and differential	25.2
[25.108] Final drive hub, steering knuckles, and shafts	25.3
[25.400] Non-powered front axle	25.4
Rear axle system.....	27
[27.100] Powered rear axle.....	27.1
[27.106] Rear bevel gear set and differential	27.2
[27.124] Final drive hub, steering knuckles, and shafts	27.3

Brakes and controls	33
[33.202] Hydraulic service brakes	33.1
[33.110] Parking brake or parking lock	33.2
Hydraulic systems.....	35
[35.000] Hydraulic systems.....	35.1
[35.300] Reservoir, cooler, and filters.....	35.2
[35.104] Fixed displacement pump.....	35.3
[35.359] Main control valve.....	35.4
[35.360] Hammer and rotating bucket hydraulic system	35.5
[35.724] Front loader hydraulic system control.....	35.6
[35.701] Front loader arm hydraulic system	35.7
[35.723] Front loader bucket hydraulic system.....	35.8
[35.726] Excavator and backhoe hydraulic controls.....	35.9
[35.736] Boom hydraulic system	35.10
[35.737] Dipper hydraulic system.....	35.11
[35.738] Excavator and backhoe bucket hydraulic system.....	35.12
[35.739] Swing arm hydraulic system	35.13
[35.AAA] Hydraulic systems generic sub-group.....	35.14
Frames and ballasting	39
[39.100] Frame	39.1
[39.129] Stabilizers	39.2
Steering.....	41
[41.101] Steering control	41.1
[41.200] Hydraulic control components.....	41.2
[41.216] Cylinders	41.3
Wheels	44
[44.511] Front wheels.....	44.1
[44.520] Rear wheels.....	44.2

[44.AAA] Wheels generic sub-group	44.3
Cab climate control	50
[50.100] Heating	50.1
[50.200] Air conditioning	50.2
Electrical systems	55
[55.000] Electrical system	55.1
[55.100] Harnesses and connectors	55.2
[55.201] Engine starting system	55.3
[55.301] Alternator	55.4
[55.011] Fuel tank system	55.5
[55.518] Wiper and washer system	55.6
Front loader and bucket	82
[82.100] Arm	82.1
[82.300] Bucket	82.2
Booms, dippers, and buckets	84
[84.114] Boom pivoting support	84.1
[84.910] Boom	84.2
[84.912] Dipper arm	84.3
Platform, cab, bodywork, and decals	90
[90.150] Cab	90.1
[90.154] Cab doors and hatches	90.2
[90.156] Cab windshield and windows	90.3
[90.100] Engine hood and panels	90.4



INTRODUCTION

Contents

INTRODUCTION

Safety rules	3
Safety rules	4
Safety rules - Ductile iron	5
Safety rules - Ductile iron	6
Safety rules	7
Personal safety	8
Safety rules - Ecology and the environment	9
Basic instructions - Important notice regarding equipment servicing	10
Basic instructions	11
Basic instructions - Fuse and relay locations	12
Basic instructions	27
Basic instructions	29
Basic instructions - Shop and assembly	30
Basic instructions - Minimum tightening torques for normal assembly	32
Electrical systems - Basic instructions - Standard torque data for hydraulics	37
Torque - Standard torque data for hydraulics	39
Abbreviation - Measurements	41
Consumables	43

Safety rules

Personal safety





This is the safety alert symbol. It is used to alert you to potential personal injury hazards. Obey all safety messages that follow this symbol to avoid possible death or injury.

Throughout this manual you will find the signal words DANGER, WARNING, and CAUTION followed by special instructions. These precautions are intended for the personal safety of you and those working with you.

Read and understand all the safety messages in this manual before you operate or service the machine.

 DANGER indicates a hazardous situation that, if not avoided, will result in death or serious injury.

 WARNING indicates a hazardous situation that, if not avoided, could result in death or serious injury.

 CAUTION indicates a hazardous situation that, if not avoided, could result in minor or moderate injury.

FAILURE TO FOLLOW DANGER, WARNING, AND CAUTION MESSAGES COULD RESULT IN DEATH OR SERIOUS INJURY.

Machine safety

NOTICE: Notice indicates a situation that, if not avoided, could result in machine or property damage.

Throughout this manual you will find the signal word Notice followed by special instructions to prevent machine or property damage. The word Notice is used to address practices not related to personal safety.

Information

NOTE: Note indicates additional information that clarifies steps, procedures, or other information in this manual.

Throughout this manual you will find the word Note followed by additional information about a step, procedure, or other information in the manual. The word Note is not intended to address personal safety or property damage.

Safety rules

⚠ DANGER

Improper operation or service of this machine can result in an accident.
Do not operate this machine or perform any lubrication, maintenance, or repair on it until you have read and understood the operation, lubrication, maintenance, and repair information.
Failure to comply will result in death or serious injury.

D0010A

⚠ WARNING

Maintenance hazard!
Always perform all service procedures punctually at the intervals stated in this manual. This ensures optimum performance levels and maximum safety during machine operation.
Failure to comply could result in death or serious injury.

W0132A

NOTICE: *Extreme working and environmental conditions require shortened service intervals.*

Use Case fluids, lubricants, and filters for the best protection and performance of your machine. All fluids, lubricants, and filters must be disposed of in compliance with environmental standards and regulations. Contact your Dealer with any questions regarding the service and maintenance of this machine.

Use this manual with the operator's manual to understand and perform the complete service procedures. Read the safety decals and information decals on the machine. Read the Operator's Manual and safety manual. Understand the operation of the machine before you start any service.

Before you service the machine, put a "Do Not Operate" tag on the steering wheel or over the key switch. Ensure the tag is at a location where everyone who might operate or service the machine may see clearly.

Plastic and resin parts

- Avoid using gasoline, paint thinner, etc. when cleaning plastic parts, console, instrument cluster, etc.
- Use only water, mild soap, and a soft cloth when you clean these parts.
- Using gasoline, thinners, etc. can cause discoloration, cracking, or deformation of the part being cleaned.

Safety rules - Ductile iron



⚠ DANGER

Altering cast ductile iron can cause it to weaken or break.

Before you weld, cut, or drill holes on any part of this machine, make sure that the part is not cast ductile iron.

Failure to comply will result in death or serious injury.

D0148A

Altering cast ductile iron can cause it to weaken or break. Unauthorized modifications to cast ductile iron parts can cause death or serious injury. Do not weld, cut, drill, repair, or attach items to cast ductile iron parts on this machine.

Before you weld, cut, or drill holes on any part of this machine, make sure the part is not cast ductile iron. See your dealer if you do not know if a part is cast ductile iron.

The following items are examples of cast ductile iron parts. There may also be other parts made of cast ductile iron that are not on the list below.

- two-wheel drive steering link
- dump links
- front axle
- stabilizers
- extend-a-hoe
- swing tower
- bucket linkage
- Air-Conditioning (A/C) compressor mounting bracket

Do not make any unauthorized modifications. Consult an authorized dealer before making any changes, additions, or modifications to this machine.

Safety rules - Ductile iron



⚠ DANGER

Improper operation or service of this machine can result in an accident. Any unauthorized modifications made to this machine can have serious consequences. Consult an authorized dealer on changes, additions, or modifications that may be required for this machine. Do not make any unauthorized modifications. Failure to comply will result in death or serious injury.

D0030A

Before you weld, cut, or drill holes on any part of this machine, make sure the part is not cast ductile iron. See your dealer if you do not know if a part is cast ductile iron. The following are cast ductile iron parts:

- two wheel drive steering link
- dump links
- front axle
- stabilizers
- extendahoe
- swing
- bucket linkage
- Air Conditioning (A/C) compressor mounting bracket

Unauthorized modifications to cast ductile iron parts can cause injury or death. Welding, cutting, or drilling can cause cast ductile iron to break. Do not weld, cut, or drill to repair or to attach items to cast ductile iron parts on this machine.

Safety rules

Unless otherwise instructed, always perform these steps before you service the machine:

1. Park the machine on a flat, level surface.
2. Place the backhoe in the transport position with the swing lock pin installed for transport.
3. Place the loader bucket on the ground, with the bottom of the loader bucket parallel to the surface.
4. Place the direction control lever and the transmission in neutral.
5. If you need to open the hood to perform service, raise the loader arms and install the support strut.
6. Shut down the engine.
7. Place a 'Do Not Operate' tag on the key switch so that it is visible to other workers or remove the key.

Personal safety

1. Make sure to arrest all fuel leaks. Any fuel or oil spilled on hot surface or electrical components may cause fire accidents. Make sure that the machine is sealed from leakage.
2. Do not allow straw, trash, bird nests or flammable material in the machine and remove the same as they can ignite fire on hot surfaces.
3. Make sure the fire extinguisher installed on or near the machine. If already equipped, the fire extinguisher is maintained and serviced according to the manufacturer's instructions.
4. Check and make sure to clean all the trash from the machine especially around hot components such as the engine, transmission, exhaust, battery, etc. Do these checks and clean the machine at least once a day, probably at the end of the day. More frequent checks and cleaning of machine may be necessary depending on the operating environment and conditions.
5. Inspect the electrical system for loose connections and frayed insulation. Repair or replace the loose or damaged parts.
6. Check and remove the debris accumulation around moving components such as bearings, pulleys, belts, gears, cleaning fans, etc. More frequent cleaning of the machine may be necessary depending on the operating environment and conditions.
7. Check all fuses, relay, and MCB's for correct ratings and validity. Replace the defective or non-complaint parts. Do not to bypass/override/tamper any safety systems of the machine.
8. Check and remove any oily rags or other flammable material on the machine. Do not to store such material around or on the machine.
9. Make sure that do not weld or flame cut any items that contain flammable material. Clean the items thoroughly with non-flammable solvents before welding or flame-cutting.
10. Immediately investigate any unusual smells or odors that may emerge during operation of the machine. Always aware of such observations and actions thereof.
11. Make sure that the machine is serviced only by authorized CASE CONSTRUCTION dealer service team and not by any external parties.
12. Check and remove any non-recommended devices that are fitted on the machine. Do not to use any devices that are not a standard fitment by the company.
13. The personnel make sure that they do not smoke or use mobiles while refuelling. It is not advisable to park the machine near a place which poses fire hazard (Workshops where welding, grinding, gas cutting etc is underway, bonfires etc).

NOTICE: Any damage to the machine due to non-adherence of the above guidelines and instructions may lead the warranty void for the machine.

Safety rules - Ecology and the environment

Soil, air, and water are vital factors of agriculture and life in general. When legislation does not yet rule the treatment of some of the substances required by advanced technology, sound judgment should govern the use and disposal of products of a chemical and petrochemical nature.

NOTE: *The following are recommendations that may be of assistance:*

- Become acquainted with and ensure that you understand the relative legislation applicable to your country.
- Where no legislation exists, obtain information from suppliers of oils, filters, batteries, fuels, antifreeze, cleaning agents, etc., with regard to their effect on man and nature and how to safely store, use, and dispose of these substances.

Helpful hints

- Avoid filling tanks using cans or inappropriate pressurized fuel delivery systems that may cause considerable spillage.
- In general, avoid skin contact with all fuels, oils, acids, solvents, etc. Most of them contain substances that may be harmful to your health.
- Modern oils contain additives. Do not burn contaminated fuels and or waste oils in ordinary heating systems.
- Avoid spillage when draining off used engine coolant mixtures, engine, gearbox and hydraulic oils, brake fluids, etc. Do not mix drained brake fluids or fuels with lubricants. Store them safely until they can be disposed of in a proper way to comply with local legislation and available resources.
- Modern coolant mixtures, i.e. antifreeze and other additives, should be replaced every two years. They should not be allowed to get into the soil, but should be collected and disposed of properly.
- Repair any leaks or defects in the engine cooling or hydraulic system immediately.
- Do not increase the pressure in a pressurized circuit as this may lead to a component failure.
- Protect hoses during welding as penetrating weld splatter may burn a hole or weaken them, allowing the loss of oils, coolant, etc.

Basic instructions - Important notice regarding equipment servicing

All repair and maintenance work listed in this manual must be carried out only by qualified dealership personnel, strictly complying with the instructions given, and using, whenever possible, the special tools.

Anyone who performs repair and maintenance operations without complying with the procedures provided herein shall be responsible for any subsequent damages.

The manufacturer and all the organizations of its distribution chain, including - without limitation - national, regional, or local CASE Dealers, reject any responsibility for damages caused by parts and/or components not approved by the manufacturer, including those used for the servicing or repair of the product manufactured or marketed by the manufacturer.

In any case, no warranty is given or attributed on the product manufactured or marketed by the manufacturer in case of damages caused by parts and/or components not approved by the manufacturer.

The information in this manual is up-to-date at the date of the publication. It is the policy of the manufacturer for continuous improvement. Some information could not be updated due to modifications of a technical or commercial type, or changes to the laws and regulations of different countries.

In case of questions, refer to your Case New Holland Construction Equipments Sales and Service Networks.

Basic instructions

⚠ WARNING

Explosive gas!

Batteries emit explosive hydrogen gas and other fumes while charging. Ventilate the charging area. Keep the battery away from sparks, open flames, and other ignition sources. Never charge a frozen battery.

Failure to comply could result in death or serious injury.

W0005A

⚠ WARNING

Hazardous chemicals!

Battery electrolyte contains sulfuric acid. Contact with skin and eyes could result in severe irritation and burns. Always wear splash-proof goggles and protective clothing (gloves and aprons). Wash hands after handling.

Failure to comply could result in death or serious injury.

W0006A

- Do not run the engine with the alternator wires disconnected.
- Before using an electric welder, disconnect the alternator wires, instrument cluster and batteries.
- Do not use a steam cleaner or a cleaning solvent to clean the alternator.
- Keep the battery vents clean. Ensure the battery vents are not restricted.

Disconnect battery

1. Open the battery compartment cover on the right hand side step of the vehicle, using the key.
2. Disconnect the negative battery cable **(1)** from the negative battery terminal.

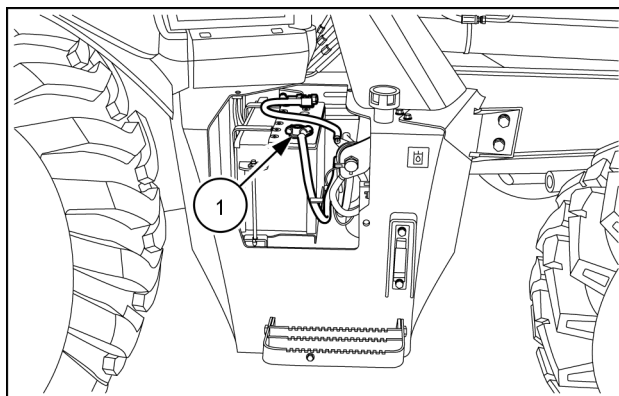

PTIL21TLB0192AB 1

Connect the battery

1. Connect the negative battery cable **(1)** to the negative battery terminal.
2. Close the battery compartment cover on the right hand side step of the vehicle, using the key.

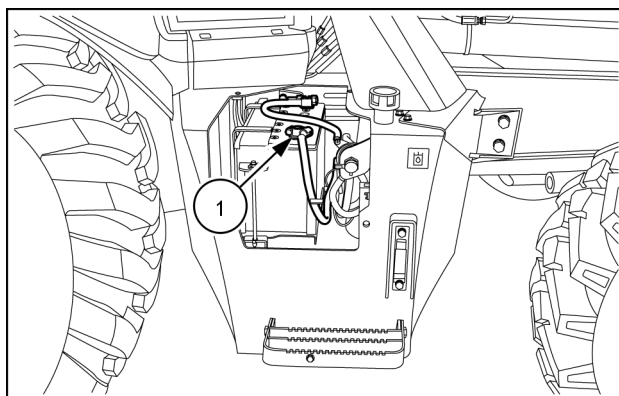

PTIL21TLB0192AB 2

Basic instructions - Fuse and relay locations

NOTICE: The fuse and relay boxes are designed to be sealed against moisture and contamination. Always replace the fuse & relay covers, and make sure the covers are securely latched, after servicing.

The machine is equipped with five fuse box locations. Two locations in the front console, two locations in the side console, and one location on the master disconnect switch.

Front console box

1. Remove the panel cover (1) from the front console box.

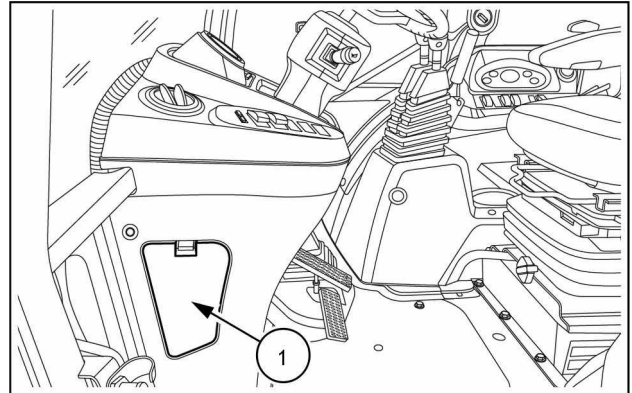

PTIL21TLB0369AB 1

2. Pull the two yellow tabs (1) outward to unlock the fuse and relay cover.
3. Squeeze the tabs underneath the yellow tabs and remove the fuse and relay cover.

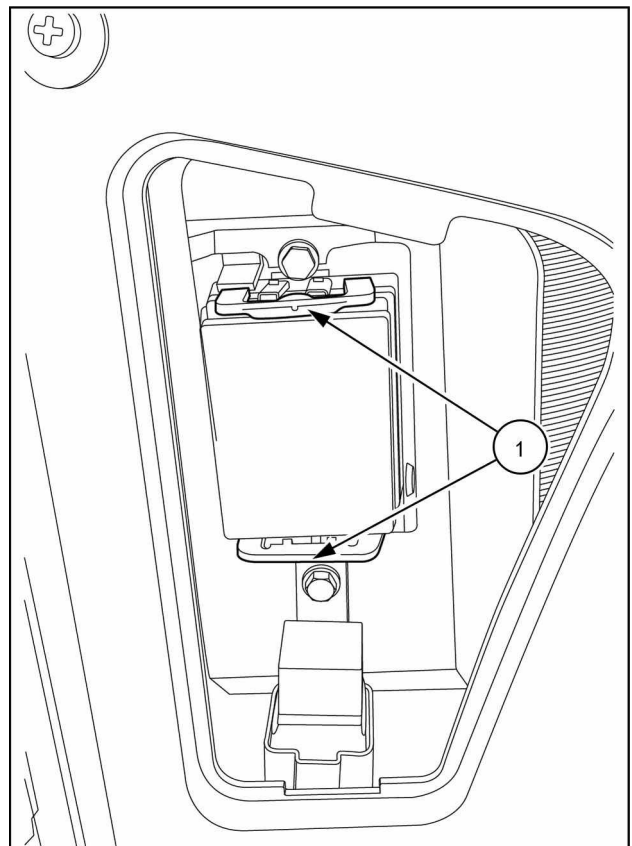

PTIL21TLB0372AB 2

INTRODUCTION

4. Replace fuse and relay with the same type and amperage.
5. Install the cover and secure the position with the yellow tabs.

NOTE: The fuse and relay decal is on the rear side of the cover.

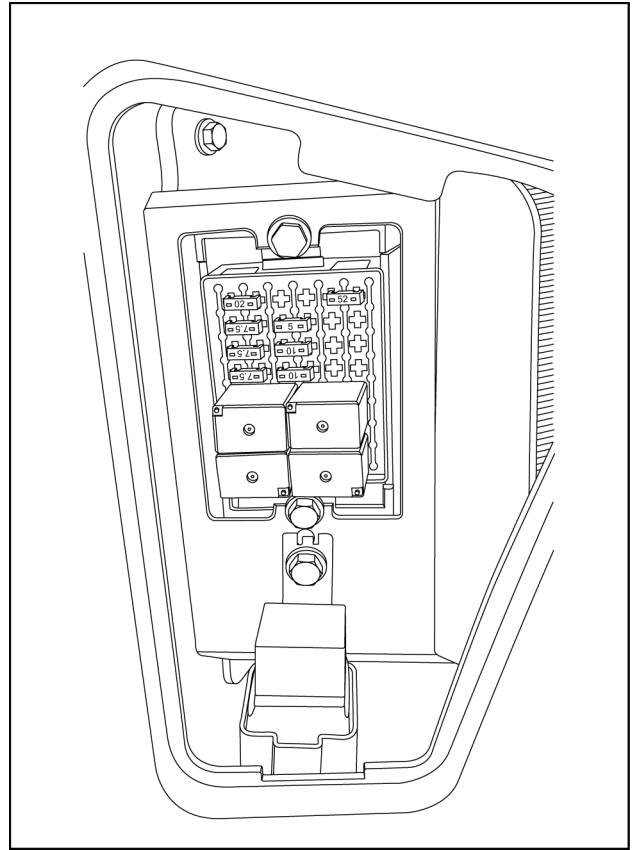

PTIL21TLB0371AB 3

The fuse and relay designations are as shown in the image.

<p>K-101</p> <p>AUX MAIN</p>	<p>K-103</p>	<p>F-101</p> <p>7.5 A</p>	<p>F-102</p> <p>EL VALVE AUX SCR</p> <p>7.5 A</p>	<p>F-103</p> <p>B+ 1</p> <p>7.5 A</p>	<p>F-104</p> <p>B+ 2</p> <p>20 A</p>
<p>K-102</p> <p>SCR MAIN</p>	<p>K-104</p> <p>N</p>	<p>F-105</p> <p>10 A</p>	<p>F-106</p> <p>10 A</p>	<p>F-107</p> <p>5 A</p>	
					<p>F-112</p> <p>AUX</p> <p>25 A</p>

PTIL21TLB0571AB 4

Side console box

1. Turn the two knob screws (1) to loosen the panel cover (2) for the fuse box.
2. Remove the panel cover from the side console box.

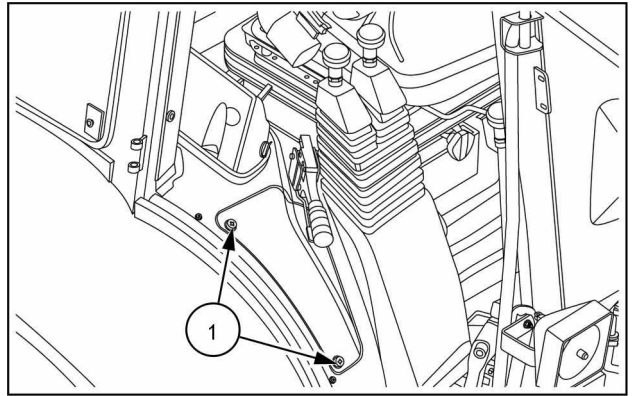

PTIL21TLB0368AB 5

3. Squeeze the tabs underneath the yellow tabs and remove the fuse and relay cover.

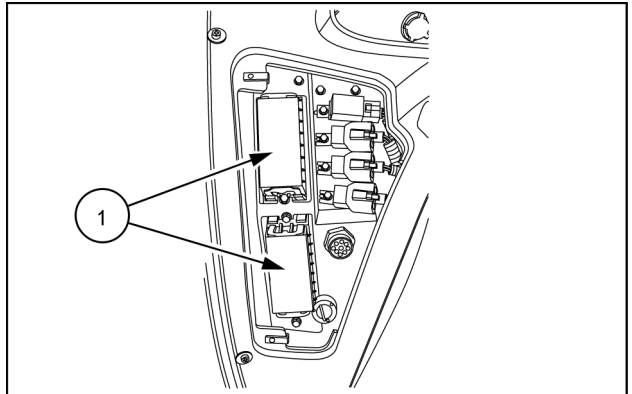

PTIL21TLB0367AB 6

3. Refer to the decal on the interior side of the panel cover for fuse, relay, and/or diode functions.

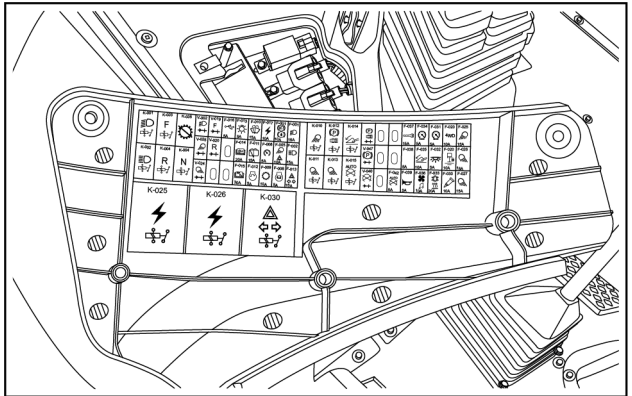

PTIL21TLB0370AB 7

The fuse and relay designations are as shown in the image.

K-001	K-003	K-005	V-020	V-019	F-016	F-013	F-010	F-007	F-001	K-010	K-012	K-014	F-027	F-024	F-021	F-020	F-021						
V-023	V-020	F-014	F-011	F-008	F-005	F-002	K-011	K-013	K-015	V-015	F-012	F-009	F-006	F-003	F-041	F-038	F-035	F-032	F-029	F-026			
K-002	K-004	K-006	V-024	F-015	F-012	F-009	F-006	F-003	K-011	K-013	K-015	V-015	F-012	F-009	F-006	F-003	F-041	F-038	F-035	F-032	F-029	F-026	
			K-025			K-026			K-030			RESERVE											
			LOOK																				

PTIL21TLB0569AB 8

Glow-plug Control Unit (GCU) fuse

1. Raise the loader arm and engage the safety support.
2. Lift the engine hood.
3. Squeeze the two locking tabs **(1)** on the fuse box cover.
4. Remove the fuse box cover.
5. Locate the **60 A** GCU fuse **(2)** on the jumpstart mounting bracket.
6. Locate the **20 A** starter fuse **(3)** on the jumpstart mounting bracket.
7. Only replace fuse and relay with the same type and amperage.
8. Install the cover until the two locking tabs lock into position.

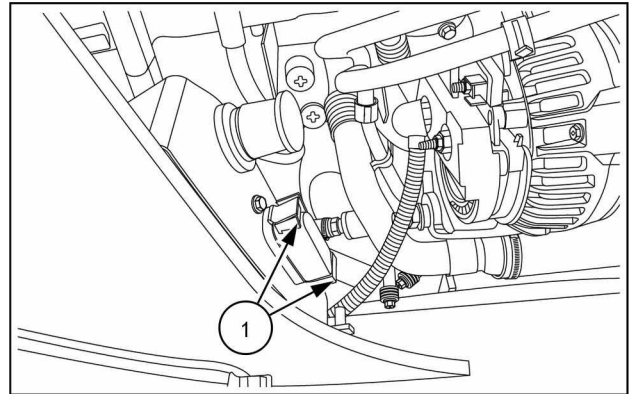

PTIL21TLB0378AB 9

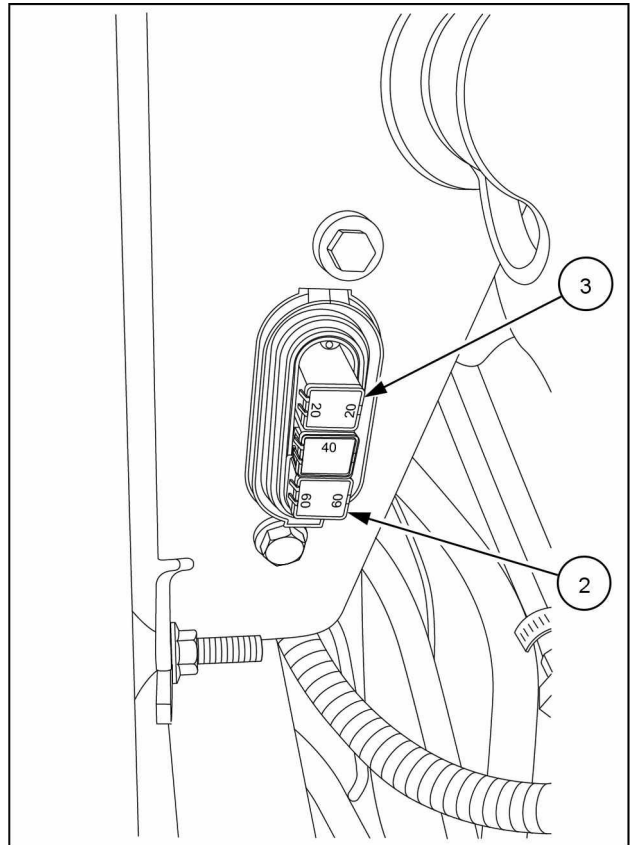

PTIL21TLB0377AB 10

Fuse, relay, and diode icon definitions

Right-hand side console panel







K-001	K-003	K-005	V-022	V-019	F-016	F-013	F-010	F-007	F-004	F-001	K-010	K-012	K-014				F-037	F-034	F-031	F-029	F-025			
K-002	K-004	K-006	V-023	V-020		F-014	F-011	F-008	F-005	F-002				V-047			F-041	F-038	F-035	F-032	F-029	F-026		
			V-024			F-015	F-012	F-009	F-006	F-003	K-011	K-013	K-015				V-049		F-042	F-039	F-036	F-033	F-030	F-027
K-025			K-026			K-030			5168167B Code															

PTIL21TLB0570FB 11

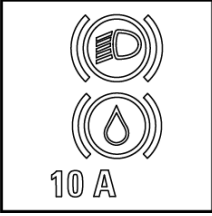
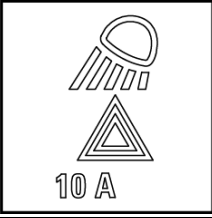
Fuse icon definitions

Icon	Function	Fuse ID (AMP)
 15A	Low beam	F-001 (15 A)
 15A	High beam	F-002 (15 A)
 15A	Hazard switch	F-003 (15 A)

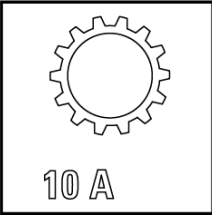

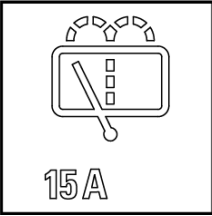
INTRODUCTION

Icon	Function	Fuse ID (AMP)
	Brake switch	F-004 (10 A)
	Flasher switch	F-005 (10 A)
	Diagnostic port	F-006 (5 A)
	Charger socket	F-007 (10 A)
	Speedometer	F-008 (5 A)
	Transmission cut-off	F-009 (10 A)
	Right-hand-side combination switch	F-010 (15 A)
	Rear wiper and washer	F-011 (15 A)

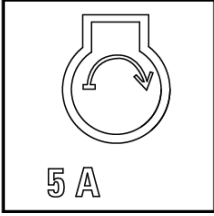
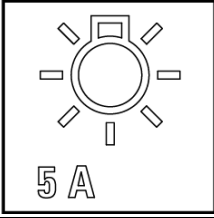
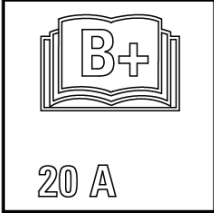
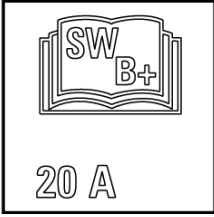
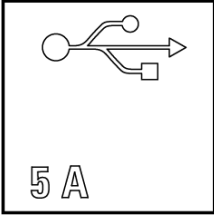
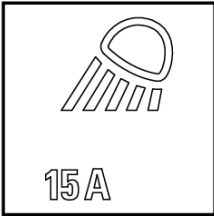
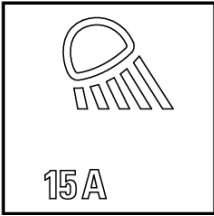
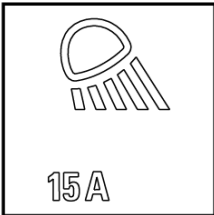

INTRODUCTION

Icon	Function	Fuse ID (AMP)
 <p>5 A</p>	Ignition switch	F-012 (5 A)
 <p>5 A</p>	License plate lamp	F-013 (5 A)
 <p>20 A</p>	Customer Option B+	F-014 (20 A)
 <p>20 A</p>	Customer Option SW B+	F-015 (20 A)
 <p>5 A</p>	USB port	F-016 (5 A)
 <p>15A</p>	Front work lights	F-025 (15 A)
 <p>15A</p>	Rear Work Lights	F-026 (15 A)
 <p>15A</p>	Rear Work Lights	F-027 (15 A)

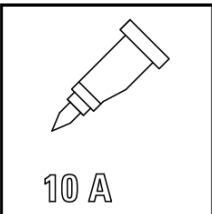
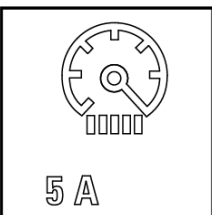
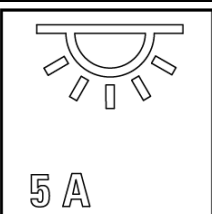
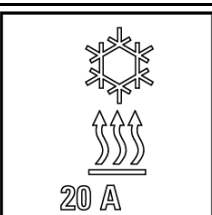
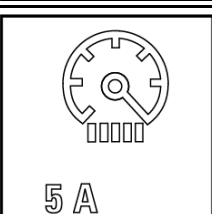
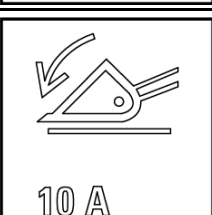
INTRODUCTION

Icon	Function	Fuse ID (AMP)
	4WD switch	F-028 (10 A)
	Side shift lock switch	F-029 (10 A)
	Foot switch	F-030 (10 A)
	Up/down control switch	F-031 (5 A)
	Dome light	F-032 (5 A)
	Air-conditioning compressor	F-033 (20 A)
	Auto-idle switch	F-034 (5 A)
	Return to dig	F-035 (10 A)

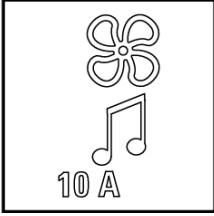
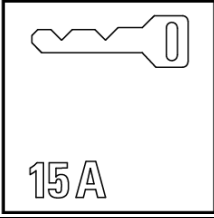
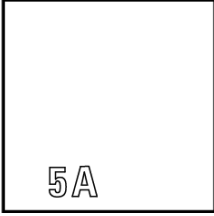
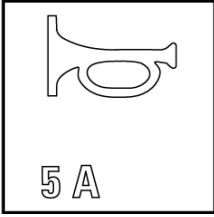
INTRODUCTION

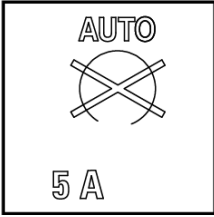



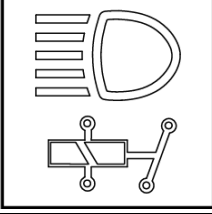
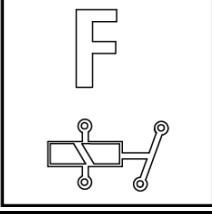
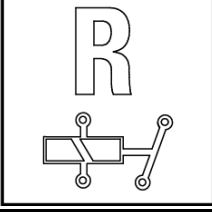
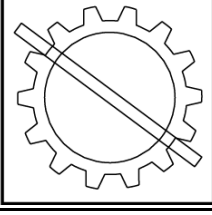
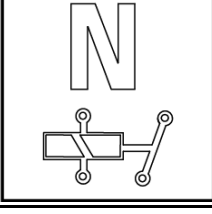
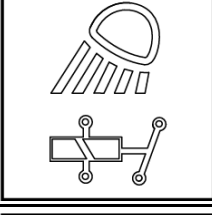
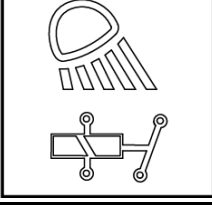

Icon	Function	Fuse ID (AMP)
 <p>10 A</p>	Cab fan switch	F-036 (10 A)
 <p>15 A</p>	Ignition key	F-037 (15 A)
 <p>5 A</p>	Telematics B+ NOTE: Icon image intentionally not shown.	F-038 (5 A)
 <p>5 A</p>	Horn	F-039 (5 A)
 <p>5 A</p>	Parking brake switch	F-041 (5 A)
 <p>AUTO 5 A</p>	Auto shutdown	F-042 (5 A)

INTRODUCTION

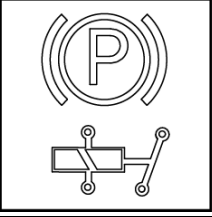
Relay icon definitions

Icon	Function	Relay ID
	Low beam relay	K-001
	High beam relay	K-002
	Forward relay	K-003
	Reverse relay	K-004
	Transmission cutout relay	K-005
	Neutral relay	K-006
	Front work lights relay	K-010
	Rear work lights relay	K-011

INTRODUCTION

Icon	Function	Relay ID
	Parking brake relay	K-012
	Rear Work Lights relay	K-013
	Return to dig relay	K-014
	Auto shutdown relay	K-015
	Shutdown power relay 1	K-025
	Shutdown power relay 2	K-026
	Flasher relay	K-030

INTRODUCTION

Diode icon definitions

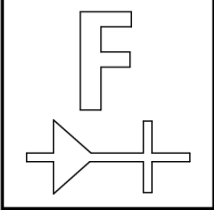
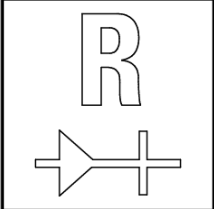
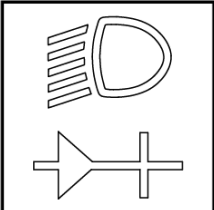
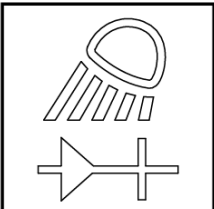
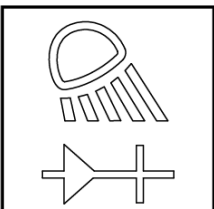
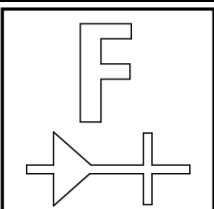
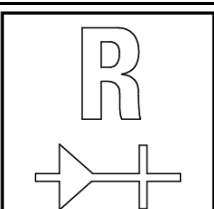
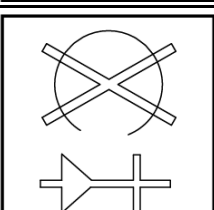

Icon	Function	Diode ID
	Forward diode	V-019
	Reverse diode	V-020
	Low beam diode	V-022
	Front work lights diode	V-023
	Rear work lights diode	V-024
	Forward diode	V-046
	Reverse diode	V-047
	Auto shutdown diode	V-048

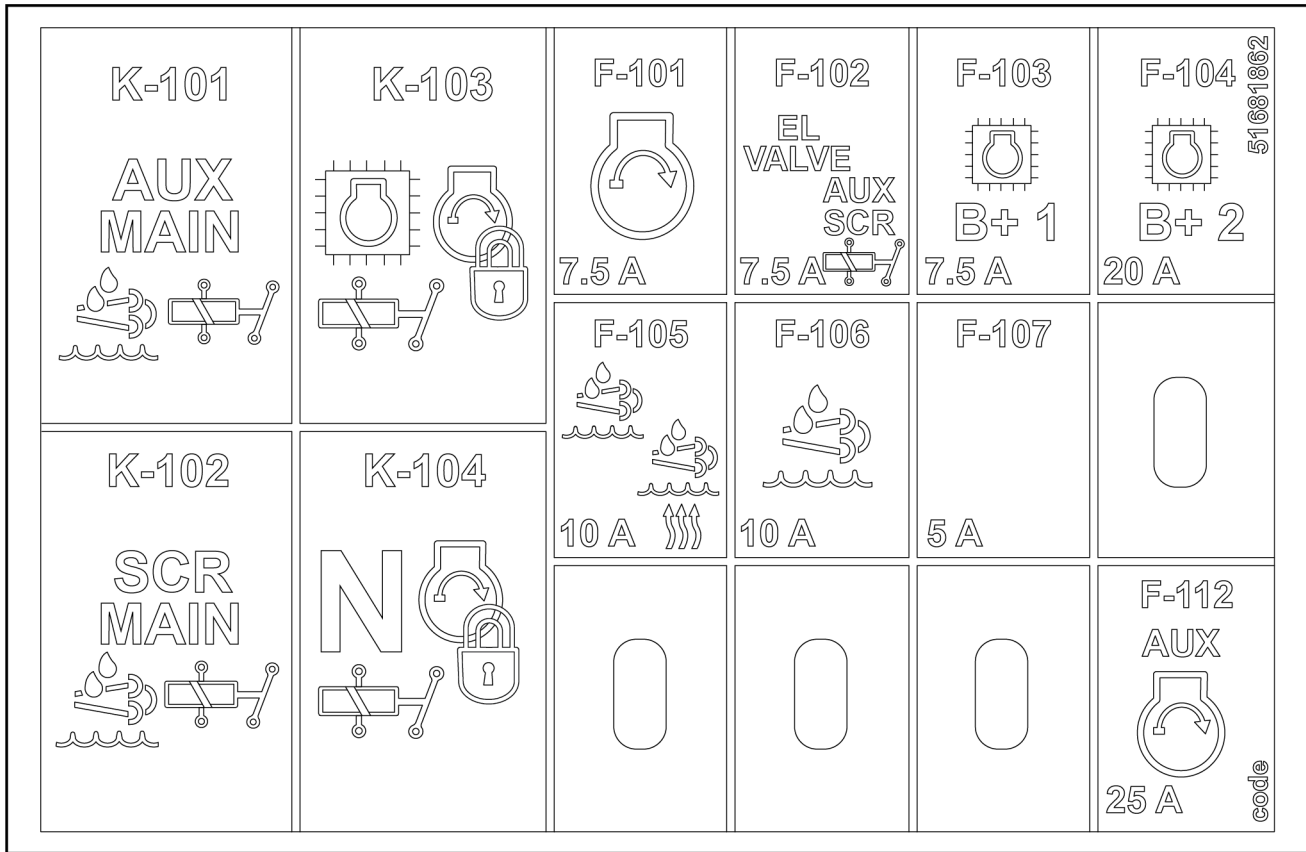
Left-hand side steering column console panel



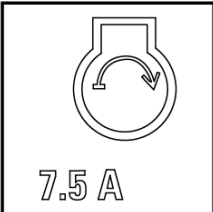

PTIL21TLB0572FB 12

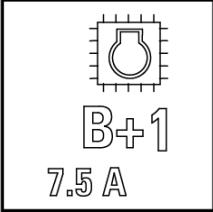

Fuse icon definitions

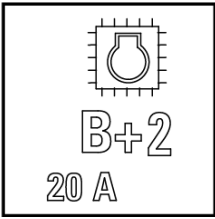
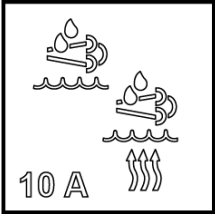
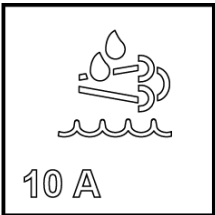
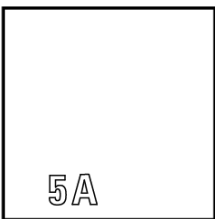
Icon	Function	Fuse ID (AMP)
 <p>7.5 A</p>	Ignition switch	F-101 (7.5 A)
 <p>EL VALVE AUX SCR 7.5 A</p>	Waste gate pressure moderator valve	F-102 (7.5 A)
 <p>B+1 7.5 A</p>	ECU fuse 1	F-103 (7.5 A)



INTRODUCTION

Icon	Function	Fuse ID (AMP)
	ECU fuse 2	F-104 (20 A)
	DEF tank level	F-105 (10 A)
	DEF tank	F-106 (10 A)
	Telematics <i>NOTE: Icon image intentionally not shown.</i>	F-107(5 A)
	Auxiliary ignition switch	F-112 (25 A)

Relay icon definitions

Icon	Function	Relay ID
	ECU start interlock relay	K-101
	Neutral start interlock relay	K-102

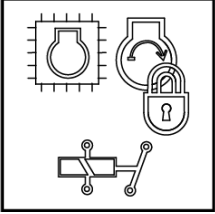
INTRODUCTION

Icon	Function	Relay ID
	ECU start interlock relay	K-103
	Neutral start interlock relay	K-104

Basic instructions

⚠ WARNING

Crushing hazard!

If you service the machine with the loader lift arms raised, always use the support strut. Remove the retaining pin and place the support strut onto the cylinder rod. Install the retaining pin into the support strut. Lower the lift arms onto the support strut.

Failure to comply could result in death or serious injury.

W0230A

Raise and support loader lift arms:

1. Empty the loader bucket.
2. Raise the loader lift arms to the maximum height.
3. Shut down the engine.

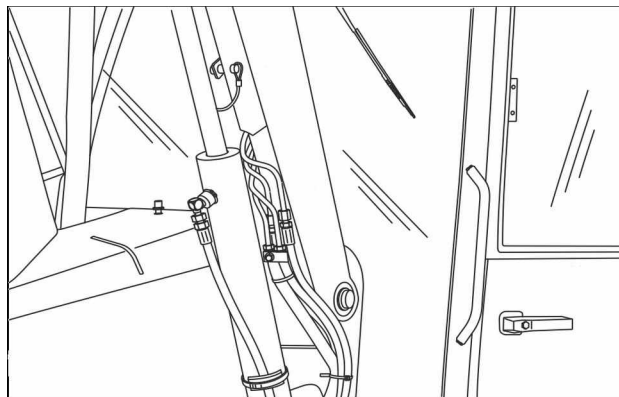

RCPH10TLB230AAF 1

4. Remove the retaining pin.
5. Lower the support strut onto the cylinder rod.
6. Install the retaining pin.

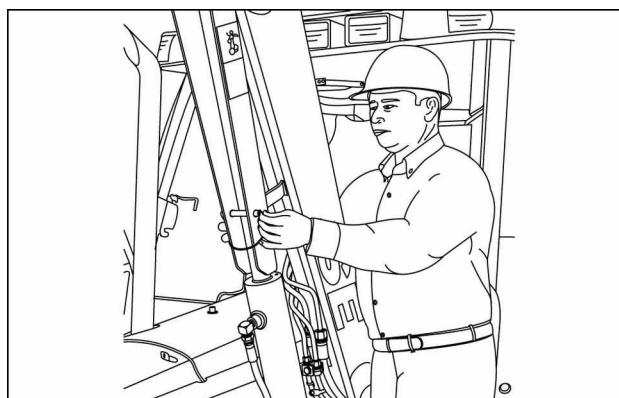

RCPH10TLB221AAF 2

7. Start the engine.
8. Slowly lower the lift arms so that the end of the support strut rests on the cylinder.

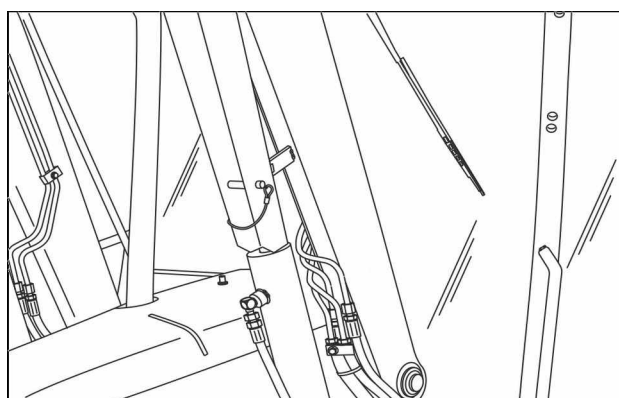

RCPH10TLB227AAF 3

INTRODUCTION

Lower supported loader lift arms:

1. Raise the lift arms so that the end of the support strut no longer rests on the cylinder.
2. Shut down the engine.

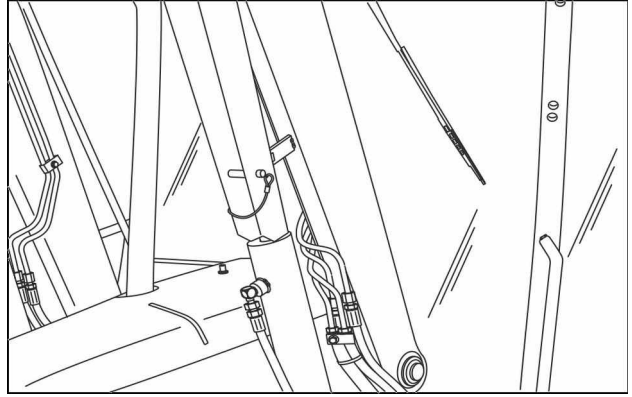

RCPH10TLB227AAF 4

3. Remove the retaining pin from the support strut.
4. Raise the support strut up to the storage position and secure with the retaining pin, as shown.

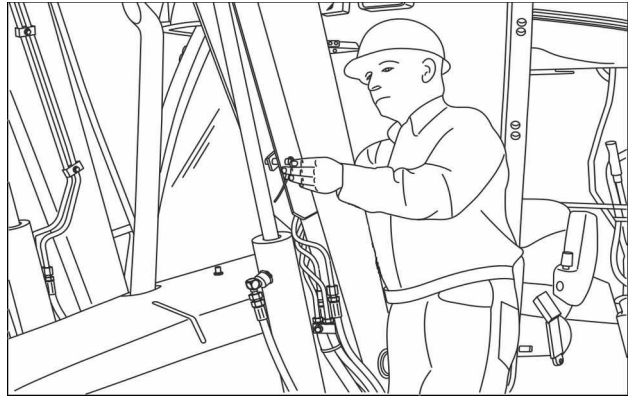

RCPH10TLB231AAF 5

5. Start the engine.
6. Lower the loader to the ground.

Basic instructions

Open the hood:

1. Shut down the engine.
2. Turn the handle **(1)** counter-clockwise to release the hood latch.

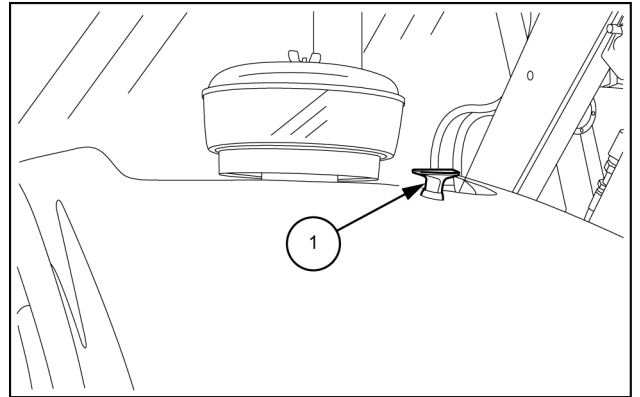

PTIL13TLB1558AB 1

3. Lift the hood and rotate forward.

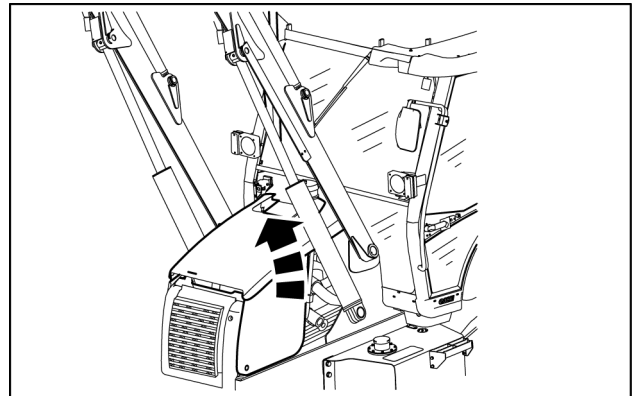

PTIL12TLB0559AB 2

NOTICE: To avoid damage to the hood parts, always close the hood before moving the loader.

Close the hood:

1. Lower the hood.
2. Turn the handle **(1)** clockwise to lock the hood latch.

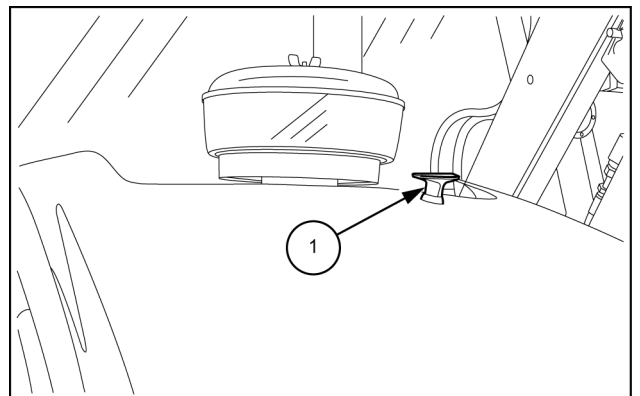

PTIL13TLB1558AB 3

Basic instructions - Shop and assembly

Shimming

For each adjustment operation, select adjusting shims and measure the adjusting shims individually using a micrometer, then add up the recorded values. Do not rely on measuring the entire shimming set, which may be incorrect, or the rated value shown on each shim.

Rotating shaft seals

For correct rotating shaft seal installation, proceed as follows:

1. Before assembly, allow the seal to soak in the oil it will be sealing for at least thirty minutes.
2. Thoroughly clean the shaft and check that the working surface on the shaft is not damaged.
3. Position the sealing lip facing the fluid.

NOTE: *With hydrodynamic lips, take into consideration the shaft rotation direction and position the grooves so that they will move the fluid towards the inner side of the seal.*

4. Coat the sealing lip with a thin layer of lubricant (use oil rather than grease). Fill the gap between the sealing lip and the dust lip on double lip seals with grease.
5. Insert the seal in its seat and press down using a flat punch or seal installation tool. Do not tap the seal with a hammer or mallet.
6. While you insert the seal, check that the seal is perpendicular to the seat. When the seal settles, make sure that the seal makes contact with the thrust element, if required.
7. To prevent damage to the seal lip on the shaft, position a protective guard during installation operations.

O-ring seals

Lubricate the O-ring seals before you insert them in the seats. This will prevent the O-ring seals from overturning and twisting, which would jeopardize sealing efficiency.

Sealing compounds

Apply a sealing compound on the mating surfaces when specified by the procedure. Before you apply the sealing compound, prepare the surfaces as directed by the product container.

Spare parts

Only use CNH Original Parts or CASE CONSTRUCTION Original Parts.

Only genuine spare parts guarantee the same quality, duration, and safety as original parts, as they are the same parts that are assembled during standard production. Only CNH Original Parts or CASE CONSTRUCTION Original Parts can offer this guarantee.

When ordering spare parts, always provide the following information:

- Machine model (commercial name) and Product Identification Number (PIN)
- Part number of the ordered part, which can be found in the parts catalog

Protecting the electronic and/or electrical systems during charging and welding

To avoid damage to the electronic and/or electrical systems, always observe the following practices:

1. Never make or break any of the charging circuit connections when the engine is running, including the battery connections.
2. Never short any of the charging components to ground.
3. Always disconnect the ground cable from the battery before arc welding on the machine or on any machine attachment.
 - Position the welder ground clamp as close to the welding area as possible.
 - If you weld in close proximity to a computer module, then you should remove the module from the machine.
 - Never allow welding cables to lie on, near, or across any electrical wiring or electronic component while you weld.
4. Always disconnect the negative cable from the battery when charging the battery in the machine with a battery charger.

NOTICE: *If you must weld on the unit, you must disconnect the battery ground cable from the machine battery. The electronic monitoring system and charging system will be damaged if this is not done.*

5. Remove the battery ground cable. Reconnect the cable when you complete welding.

Special tools

▲ WARNING

Battery acid causes burns. Batteries contain sulfuric acid.

Avoid contact with skin, eyes or clothing. Antidote (external): Flush with water. Antidote (eyes): flush with water for 15 minutes and seek medical attention immediately. Antidote (internal): Drink large quantities of water or milk. Do not induce vomiting. Seek medical attention immediately.

Failure to comply could result in death or serious injury.

W0111A

The special tools that CASE CONSTRUCTION suggests and illustrate in this manual have been specifically researched and designed for use with CASE CONSTRUCTION machines. The special tools are essential for reliable repair operations. The special tools are accurately built and rigorously tested to offer efficient and long-lasting operation.

By using these tools, repair personnel will benefit from:

- Operating in optimal technical conditions
- Obtaining the best results
- Saving time and effort
- Working in safe conditions

Basic instructions - Minimum tightening torques for normal assembly

METRIC NON-FLANGED HARDWARE

NOM. SIZE	CLASS 8.8 BOLT and CLASS 8 NUT		CLASS 10.9 BOLT and CLASS 10 NUT		LOCKNUT CL.8 W/CL8.8 BOLT	LOCKNUT CL.10 W/CL10.9 BOLT
	UNPLATED	PLATED W/ZnCr	UNPLATED	PLATED W/ZnCr		
M4	2.2 N·m (19 lb in)	2.9 N·m (26 lb in)	3.2 N·m (28 lb in)	4.2 N·m (37 lb in)	2 N·m (18 lb in)	2.9 N·m (26 lb in)
M5	4.5 N·m (40 lb in)	5.9 N·m (52 lb in)	6.4 N·m (57 lb in)	8.5 N·m (75 lb in)	4 N·m (36 lb in)	5.8 N·m (51 lb in)
M6	7.5 N·m (66 lb in)	10 N·m (89 lb in)	11 N·m (96 lb in)	15 N·m (128 lb in)	6.8 N·m (60 lb in)	10 N·m (89 lb in)
M8	18 N·m (163 lb in)	25 N·m (217 lb in)	26 N·m (234 lb in)	35 N·m (311 lb in)	17 N·m (151 lb in)	24 N·m (212 lb in)
M10	37 N·m (27 lb ft)	49 N·m (36 lb ft)	52 N·m (38 lb ft)	70 N·m (51 lb ft)	33 N·m (25 lb ft)	48 N·m (35 lb ft)
M12	64 N·m (47 lb ft)	85 N·m (63 lb ft)	91 N·m (67 lb ft)	121 N·m (90 lb ft)	58 N·m (43 lb ft)	83 N·m (61 lb ft)
M16	158 N·m (116 lb ft)	210 N·m (155 lb ft)	225 N·m (166 lb ft)	301 N·m (222 lb ft)	143 N·m (106 lb ft)	205 N·m (151 lb ft)
M20	319 N·m (235 lb ft)	425 N·m (313 lb ft)	440 N·m (325 lb ft)	587 N·m (433 lb ft)	290 N·m (214 lb ft)	400 N·m (295 lb ft)
M24	551 N·m (410 lb ft)	735 N·m (500 lb ft)	762 N·m (560 lb ft)	1016 N·m (750 lb ft)	501 N·m (370 lb ft)	693 N·m (510 lb ft)

NOTE: M4 through M8 hardware torque specifications are shown in pound-inches. M10 through M24 hardware torque specifications are shown in pound-feet.

METRIC FLANGED HARDWARE

NOM. SIZE	CLASS 8.8 BOLT and CLASS 8 NUT		CLASS 10.9 BOLT and CLASS 10 NUT		LOCKNUT CL.8 W/CL8.8 BOLT	LOCKNUT CL.10 W/CL10.9 BOLT
	UNPLATED	PLATED W/ZnCr	UNPLATED	PLATED W/ZnCr		
M4	2.4 N·m (21 lb in)	3.2 N·m (28 lb in)	3.5 N·m (31 lb in)	4.6 N·m (41 lb in)	2.2 N·m (19 lb in)	3.1 N·m (27 lb in)
M5	4.9 N·m (43 lb in)	6.5 N·m (58 lb in)	7.0 N·m (62 lb in)	9.4 N·m (83 lb in)	4.4 N·m (39 lb in)	6.4 N·m (57 lb in)
M6	8.3 N·m (73 lb in)	11 N·m (96 lb in)	12 N·m (105 lb in)	16 N·m (141 lb in)	7.5 N·m (66 lb in)	11 N·m (96 lb in)
M8	20 N·m (179 lb in)	27 N·m (240 lb in)	29 N·m (257 lb in)	39 N·m (343 lb in)	18 N·m (163 lb in)	27 N·m (240 lb in)
M10	40 N·m (30 lb ft)	54 N·m (40 lb ft)	57 N·m (42 lb ft)	77 N·m (56 lb ft)	37 N·m (27 lb ft)	53 N·m (39 lb ft)
M12	70 N·m (52 lb ft)	93 N·m (69 lb ft)	100 N·m (74 lb ft)	134 N·m (98 lb ft)	63 N·m (47 lb ft)	91 N·m (67 lb ft)
M16	174 N·m (128 lb ft)	231 N·m (171 lb ft)	248 N·m (183 lb ft)	331 N·m (244 lb ft)	158 N·m (116 lb ft)	226 N·m (167 lb ft)
M20	350 N·m (259 lb ft)	467 N·m (345 lb ft)	484 N·m (357 lb ft)	645 N·m (476 lb ft)	318 N·m (235 lb ft)	440 N·m (325 lb ft)
M24	607 N·m (447 lb ft)	809 N·m (597 lb ft)	838 N·m (618 lb ft)	1118 N·m (824 lb ft)	552 N·m (407 lb ft)	

IDENTIFICATION

Metric Hex head and carriage bolts, classes 5.6 and up

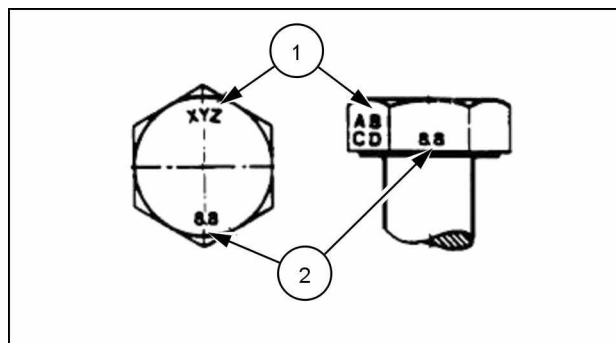

20083680 1

1. Manufacturer's Identification
2. Property Class

Metric Hex nuts and locknuts, classes 05 and up

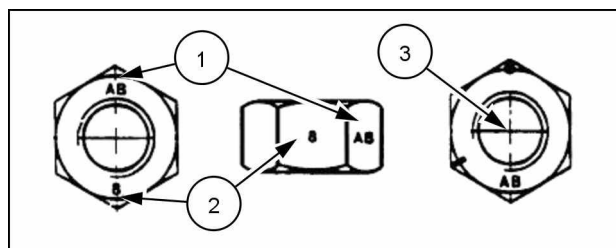

20083681 2

1. Manufacturer's Identification
2. Property Class
3. Clock Marking of Property Class and Manufacturer's Identification (Optional), i.e. marks **60°** apart indicate Class 10 properties, and marks **120°** apart indicate Class 8.

INCH NON-FLANGED HARDWARE

NOMINAL SIZE	SAE GRADE 5 BOLT and NUT		SAE GRADE 8 BOLT and NUT		LOCKNUT GrB W/ Gr5 BOLT	LOCKNUT GrC W/ Gr8 BOLT
	UN-PLATED or PLATED SILVER	PLATED W/ZnCr GOLD	UN-PLATED or PLATED SILVER	PLATED W/ZnCr GOLD		
1/4	8 N·m (71 lb in)	11 N·m (97 lb in)	12 N·m (106 lb in)	16 N·m (142 lb in)	8.5 N·m (75 lb in)	12.2 N·m (109 lb in)
5/16	17 N·m (150 lb in)	23 N·m (204 lb in)	24 N·m (212 lb in)	32 N·m (283 lb in)	17.5 N·m (155 lb in)	25 N·m (220 lb in)
3/8	30 N·m (22 lb ft)	40 N·m (30 lb ft)	43 N·m (31 lb ft)	57 N·m (42 lb ft)	31 N·m (23 lb ft)	44 N·m (33 lb ft)
7/16	48 N·m (36 lb ft)	65 N·m (48 lb ft)	68 N·m (50 lb ft)	91 N·m (67 lb ft)	50 N·m (37 lb ft)	71 N·m (53 lb ft)
1/2	74 N·m (54 lb ft)	98 N·m (73 lb ft)	104 N·m (77 lb ft)	139 N·m (103 lb ft)	76 N·m (56 lb ft)	108 N·m (80 lb ft)
9/16	107 N·m (79 lb ft)	142 N·m (105 lb ft)	150 N·m (111 lb ft)	201 N·m (148 lb ft)	111 N·m (82 lb ft)	156 N·m (115 lb ft)
5/8	147 N·m (108 lb ft)	196 N·m (145 lb ft)	208 N·m (153 lb ft)	277 N·m (204 lb ft)	153 N·m (113 lb ft)	215 N·m (159 lb ft)
3/4	261 N·m (193 lb ft)	348 N·m (257 lb ft)	369 N·m (272 lb ft)	491 N·m (362 lb ft)	271 N·m (200 lb ft)	383 N·m (282 lb ft)
7/8	420 N·m (310 lb ft)	561 N·m (413 lb ft)	594 N·m (438 lb ft)	791 N·m (584 lb ft)	437 N·m (323 lb ft)	617 N·m (455 lb ft)
1	630 N·m (465 lb ft)	841 N·m (620 lb ft)	890 N·m (656 lb ft)	1187 N·m (875 lb ft)	654 N·m (483 lb ft)	924 N·m (681 lb ft)

NOTE: For Imperial Units, 1/4 in and 5/16 in hardware torque specifications are shown in pound-inches. 3/8 in through 1 in hardware torque specifications are shown in pound-feet.

INCH FLANGED HARDWARE

NOM- INAL SIZE	SAE GRADE 5 BOLT and NUT		SAE GRADE 8 BOLT and NUT		LOCKNUT GrF W/ Gr5 BOLT	LOCKNUT GrG W/ Gr8 BOLT
	UNPLATED or PLATED SILVER	PLATED W/ZnCr GOLD	UNPLATED or PLATED SILVER	PLATED W/ZnCr GOLD		
1/4	9 N·m (80 lb in)	12 N·m (106 lb in)	13 N·m (115 lb in)	17 N·m (150 lb in)	8 N·m (71 lb in)	12 N·m (106 lb in)
5/16	19 N·m (168 lb in)	25 N·m (221 lb in)	26 N·m (230 lb in)	35 N·m (310 lb in)	17 N·m (150 lb in)	24 N·m (212 lb in)
3/8	33 N·m (25 lb ft)	44 N·m (33 lb ft)	47 N·m (35 lb ft)	63 N·m (46 lb ft)	30 N·m (22 lb ft)	43 N·m (32 lb ft)
7/16	53 N·m (39 lb ft)	71 N·m (52 lb ft)	75 N·m (55 lb ft)	100 N·m (74 lb ft)	48 N·m (35 lb ft)	68 N·m (50 lb ft)
1/2	81 N·m (60 lb ft)	108 N·m (80 lb ft)	115 N·m (85 lb ft)	153 N·m (113 lb ft)	74 N·m (55 lb ft)	104 N·m (77 lb ft)
9/16	117 N·m (86 lb ft)	156 N·m (115 lb ft)	165 N·m (122 lb ft)	221 N·m (163 lb ft)	106 N·m (78 lb ft)	157 N·m (116 lb ft)
5/8	162 N·m (119 lb ft)	216 N·m (159 lb ft)	228 N·m (168 lb ft)	304 N·m (225 lb ft)	147 N·m (108 lb ft)	207 N·m (153 lb ft)
3/4	287 N·m (212 lb ft)	383 N·m (282 lb ft)	405 N·m (299 lb ft)	541 N·m (399 lb ft)	261 N·m (193 lb ft)	369 N·m (272 lb ft)
7/8	462 N·m (341 lb ft)	617 N·m (455 lb ft)	653 N·m (482 lb ft)	871 N·m (642 lb ft)	421 N·m (311 lb ft)	594 N·m (438 lb ft)
1	693 N·m (512 lb ft)	925 N·m (682 lb ft)	979 N·m (722 lb ft)	1305 N·m (963 lb ft)	631 N·m (465 lb ft)	890 N·m (656 lb ft)

IDENTIFICATION

Inch Bolts and free-spinning nuts

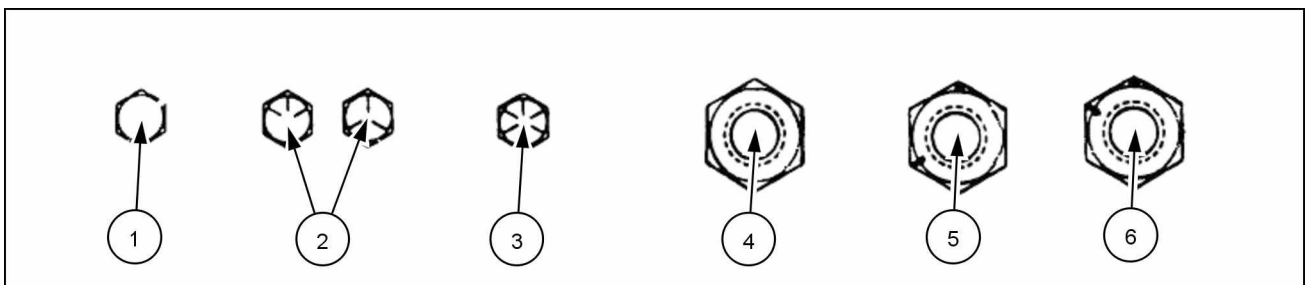

20083682 3

Grade Marking Examples

SAE Grade Identification			
1	Grade 2 - No Marks	4	Grade 2 Nut - No Marks
2	Grade 5 - Three Marks	5	Grade 5 Nut - Marks 120° Apart
3	Grade 8 - Five Marks	6	Grade 8 Nut - Marks 60° Apart

Inch Lock Nuts, All Metal (Three optional methods)

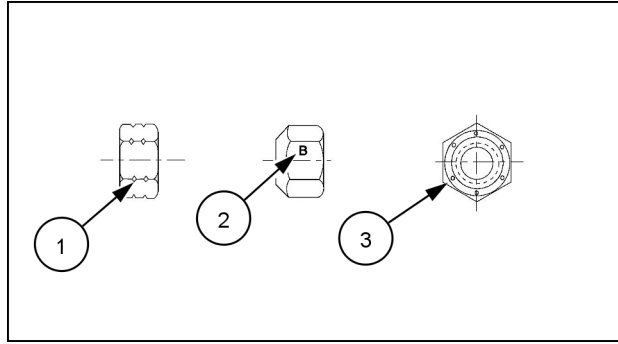

20090268 4

Grade Identification

Grade	Corner Marking Method (1)	Flats Marking Method (2)	Clock Marking Method (3)
Grade A	No Notches	No Mark	No Marks
Grade B	One Circumferential Notch	Letter B	Three Marks
Grade C	Two Circumferential Notches	Letter C	Six Marks

Electrical systems - Basic instructions - Standard torque data for hydraulics

INSTALLATION OF ADJUSTABLE FITTINGS IN STRAIGHT THREAD O RING BOSSES

1. Lubricate the O-ring by coating it with a light oil or petroleum. Install the O-ring in the groove adjacent to the metal backup washer which is assembled at the extreme end of the groove (4).
2. Install the fitting into the SAE straight thread boss until the metal backup washer contacts the face of the boss (5).

NOTE: Do not over tighten and distort the metal backup washer.

3. Position the fitting by turning out (counterclockwise) up to a maximum of one turn. Holding the pad of the fitting with a wrench, tighten the locknut and washer against the face of the boss (6).

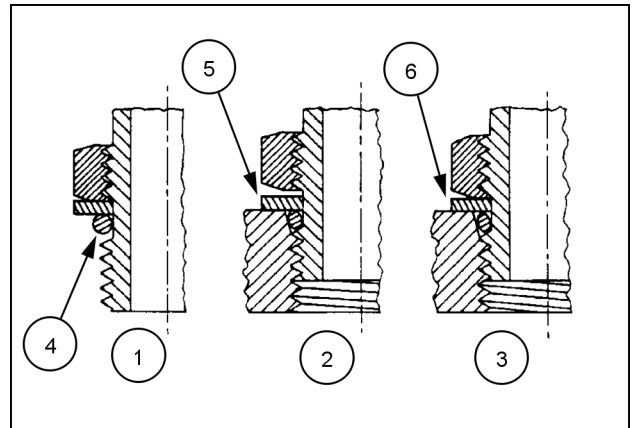

23085659 1

STANDARD TORQUE DATA FOR HYDRAULIC TUBES AND FITTINGS

TUBE NUTS FOR 37° FLARED FITTINGS				O-RING BOSS PLUGS ADJUSTABLE FITTING LOCKNUTS, SWIVEL JIC- 37° SEATS
SIZE	TUBING OD	THREAD SIZE	TORQUE	TORQUE
4	6.4 mm (1/4 in)	7/16-20	12 – 16 N·m (9 – 12 lb ft)	8 – 14 N·m (6 – 10 lb ft)
5	7.9 mm (5/16 in)	1/2-20	16 – 20 N·m (12 – 15 lb ft)	14 – 20 N·m (10 – 15 lb ft)
6	9.5 mm (3/8 in)	9/16-18	29 – 33 N·m (21 – 24 lb ft)	20 – 27 N·m (15 – 20 lb ft)
8	12.7 mm (1/2 in)	3/4-16	47 – 54 N·m (35 – 40 lb ft)	34 – 41 N·m (25 – 30 lb ft)
10	15.9 mm (5/8 in)	7/8-14	72 – 79 N·m (53 – 58 lb ft)	47 – 54 N·m (35 – 40 lb ft)
12	19.1 mm (3/4 in)	1-1/16-12	104 – 111 N·m (77 – 82 lb ft)	81 – 95 N·m (60 – 70 lb ft)
14	22.2 mm (7/8 in)	1-3/16-12	122 – 136 N·m (90 – 100 lb ft)	95 – 109 N·m (70 – 80 lb ft)
16	25.4 mm (1 in)	1-5/16-12	149 – 163 N·m (110 – 120 lb ft)	108 – 122 N·m (80 – 90 lb ft)
20	31.8 mm (1-1/4 in)	1-5/8-12	190 – 204 N·m (140 – 150 lb ft)	129 – 158 N·m (95 – 115 lb ft)
24	38.1 mm (1-1/2 in)	1-7/8-12	217 – 237 N·m (160 – 175 lb ft)	163 – 190 N·m (120 – 140 lb ft)
32	50.8 mm (2 in)	2-1/2-12	305 – 325 N·m (225 – 240 lb ft)	339 – 407 N·m (250 – 300 lb ft)

These torques are not recommended for tubes of 12.7 mm (1/2 in) OD and larger with wall thickness of 0.889 mm (0.035 in) or less. The torque is specified for 0.889 mm (0.035 in) wall tubes on each application individually.

Before installing and torquing 37° flared fittings, clean the face of the flare and threads with a clean solvent or Loctite cleaner and apply hydraulic sealant to the 37° flare and the threads.

Install fitting and torque to specified torque, loosen fitting and retorque to specifications.

PIPE THREAD FITTING TORQUE

Before installing and tightening pipe fittings, clean the threads with a clean solvent or Loctite cleaner and apply sealant for all fittings including stainless steel or for most metal fittings. For high filtration/zero contamination systems use .

PIPE THREAD FITTING	
Thread Size	Torque (Maximum)
1/8-27	13 N·m (10 lb ft)
1/4-18	16 N·m (12 lb ft)
3/8-18	22 N·m (16 lb ft)
1/2-14	41 N·m (30 lb ft)
3/4-14	54 N·m (40 lb ft)

INSTALLATION OF ORFS (O-RING FLAT FACED) FITTINGS

When installing ORFS fittings thoroughly clean both flat surfaces of the fittings **(1)** and lubricate the O-ring **(2)** with light oil. Make sure both surfaces are aligned properly. Torque the fitting to specified torque listed throughout the repair manual.

NOTICE: If the fitting surfaces are not properly cleaned, the O-ring will not seal properly. If the fitting surfaces are not properly aligned, the fittings may be damaged and will not seal properly.

NOTICE: Always use genuine factory replacement oils and filters to ensure proper lubrication and filtration of engine and hydraulic system oils.

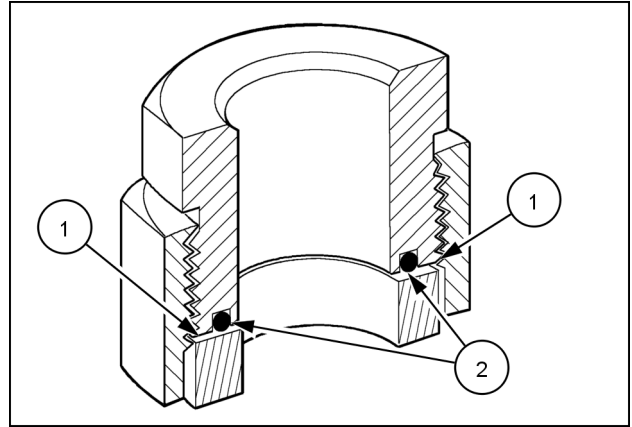

50011183 2

The use of proper oils, grease, and keeping the hydraulic system clean will extend machine and component life.

Torque - Standard torque data for hydraulics

INSTALLATION OF ADJUSTABLE FITTINGS IN STRAIGHT THREAD O RING BOSSES

1. Lubricate the O-ring by coating it with a light oil or petroleum. Install the O-ring in the groove adjacent to the metal backup washer which is assembled at the extreme end of the groove (4).
2. Install the fitting into the SAE straight thread boss until the metal backup washer contacts the face of the boss (5).

NOTE: Do not over tighten and distort the metal backup washer.

3. Position the fitting by turning out (counterclockwise) up to a maximum of one turn. Holding the pad of the fitting with a wrench, tighten the locknut and washer against the face of the boss (6).

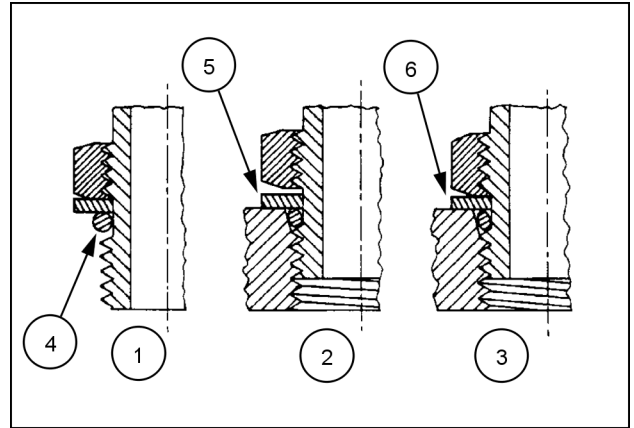

23085659 1

STANDARD TORQUE DATA FOR HYDRAULIC TUBES AND FITTINGS

TUBE NUTS FOR 37° FLARED FITTINGS				O-RING BOSS PLUGS ADJUSTABLE FITTING LOCKNUTS, SWIVEL JIC- 37° SEATS
SIZE	TUBING OD	THREAD SIZE	TORQUE	TORQUE
4	6.4 mm (1/4 in)	7/16-20	12 – 16 N·m (9 – 12 lb ft)	8 – 14 N·m (6 – 10 lb ft)
5	7.9 mm (5/16 in)	1/2-20	16 – 20 N·m (12 – 15 lb ft)	14 – 20 N·m (10 – 15 lb ft)
6	9.5 mm (3/8 in)	9/16-18	29 – 33 N·m (21 – 24 lb ft)	20 – 27 N·m (15 – 20 lb ft)
8	12.7 mm (1/2 in)	3/4-16	47 – 54 N·m (35 – 40 lb ft)	34 – 41 N·m (25 – 30 lb ft)
10	15.9 mm (5/8 in)	7/8-14	72 – 79 N·m (53 – 58 lb ft)	47 – 54 N·m (35 – 40 lb ft)
12	19.1 mm (3/4 in)	1-1/16-12	104 – 111 N·m (77 – 82 lb ft)	81 – 95 N·m (60 – 70 lb ft)
14	22.2 mm (7/8 in)	1-3/16-12	122 – 136 N·m (90 – 100 lb ft)	95 – 109 N·m (70 – 80 lb ft)
16	25.4 mm (1 in)	1-5/16-12	149 – 163 N·m (110 – 120 lb ft)	108 – 122 N·m (80 – 90 lb ft)
20	31.8 mm (1-1/4 in)	1-5/8-12	190 – 204 N·m (140 – 150 lb ft)	129 – 158 N·m (95 – 115 lb ft)
24	38.1 mm (1-1/2 in)	1-7/8-12	217 – 237 N·m (160 – 175 lb ft)	163 – 190 N·m (120 – 140 lb ft)
32	50.8 mm (2 in)	2-1/2-12	305 – 325 N·m (225 – 240 lb ft)	339 – 407 N·m (250 – 300 lb ft)

These torques are not recommended for tubes of 12.7 mm (1/2 in) OD and larger with wall thickness of 0.889 mm (0.035 in) or less. The torque is specified for 0.889 mm (0.035 in) wall tubes on each application individually.

Before installing and torquing 37° flared fittings, clean the face of the flare and threads with a clean solvent or Loctite cleaner and apply hydraulic sealant to the 37° flare and the threads.

Install fitting and torque to specified torque, loosen fitting and retorque to specifications.

PIPE THREAD FITTING TORQUE

Before installing and tightening pipe fittings, clean the threads with a clean solvent or Loctite cleaner and apply sealant for all fittings including stainless steel or for most metal fittings. For high filtration/zero contamination systems use .

PIPE THREAD FITTING	
Thread Size	Torque (Maximum)
1/8-27	13 N·m (10 lb ft)
1/4-18	16 N·m (12 lb ft)
3/8-18	22 N·m (16 lb ft)
1/2-14	41 N·m (30 lb ft)
3/4-14	54 N·m (40 lb ft)

INSTALLATION OF ORFS (O-RING FLAT FACED) FITTINGS

When installing ORFS fittings thoroughly clean both flat surfaces of the fittings **(1)** and lubricate the O-ring **(2)** with light oil. Make sure both surfaces are aligned properly. Torque the fitting to specified torque listed throughout the repair manual.

NOTICE: If the fitting surfaces are not properly cleaned, the O-ring will not seal properly. If the fitting surfaces are not properly aligned, the fittings may be damaged and will not seal properly.

NOTICE: Always use genuine factory replacement oils and filters to ensure proper lubrication and filtration of engine and hydraulic system oils.

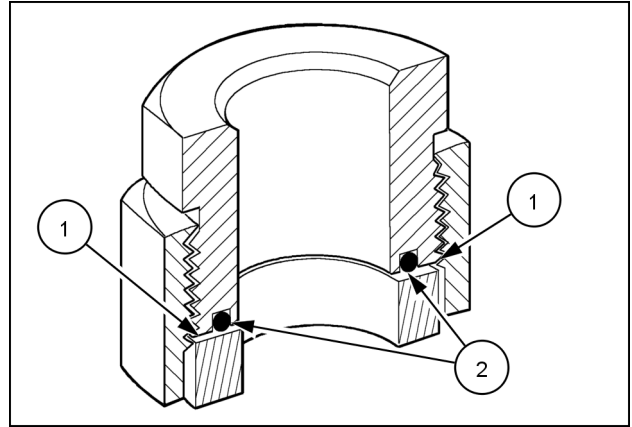

50011183 2

The use of proper oils, grease, and keeping the hydraulic system clean will extend machine and component life.

Abbreviation - Measurements

Typical applications	Metric unit		Imperial unit	
	Name	Symbol	Name	Symbol
Area (Land area)				
	hectare	ha	acre	ac
	square meter	m ²	square foot	ft ²
			square inch	in ²
	square millimeter	mm ²	square inch	in ²
Electricity				
	ampere	A	ampere	A
	volt	V	volt	V
	microfarad	μF	microfarad	μF
	ohm	Ω	ohm	Ω
Force				
	kilonewton	kN	pound	lb
	newton	N	pound	lb
Force per length				
	newton per meter	N/m	pound per foot	lb/ft
			pound per inch	lb/in
Frequency				
	megahertz	MHz	megahertz	MHz
	kilohertz	kHz	kilohertz	kHz
	hertz	Hz	hertz	Hz
Frequency - Rotational				
	revolution per minute	r/min rpm	revolution per minute	r/min ^a rpm
Length				
	kilometer	km	mile	mi
	meter	m	foot	ft
	centimeter	cm	inch	in
	millimeter	mm	inch	in
	micrometer	μm		
Mass				
	kilogram	kg	pound	lb
	gram	g	ounce	oz
	milligram	mg		
Power				
	kilowatt	kW	horsepower	Hp
	watt	W	Btu per hour	Btu/hr
			Btu per minute	Btu/min
Pressure or stress (Force per area)				
	kilopascal	kPa	pound per square inch	psi
			inch of mercury	inHg
	pascal	Pa	inch of water	inH ₂ O
	megapascal	MPa	pound per square inch	psi

INTRODUCTION

Typical applications	Metric unit		Imperial unit	
	Name	Symbol	Name	Symbol
Temperature (other than Thermodynamic)				
	degrees Celsius	°C	degrees Fahrenheit	°F
Time				
	hour	h	hour	h
	minute	min	minute	min
	second	s	second	s
Torque (includes Bending moment, Moment of force, and Moment of a couple)				
	newton meter	N m	pound foot	lb ft
			pound foot	lb in
Velocity				
	kilometer per hour	km/h	mile per hour	mph
	meter per second	m/s	foot per second	ft/s
	millimeter per second	mm/s	inch per second	in/s
	meter per minute	m/min	foot per minute	ft/min
Volume (includes Capacity)				
	cubic meter	m ³	cubic yard	yd ³
				cu yd
	liter	l	cubic inch	in ³
	liter	l	US gallon	US gal
			UK gallon	UK gal
			US quart	US qt
			UK quart	UK qt
	milliliter	ml	fluid ounce	fl oz
Volume per time (includes Discharge and Flow rate)				
	cubic meter per minute	m ³ /min	cubic foot per minute	ft ³ /min
	liter per minute	l/min	US gallon per minute	US gal/min
	milliliter per minute	ml/min	UK gallon per minute	UK gal/min
Sound power level and Sound pressure level				
	decibel	dB	decibel	dB

Consumables

S.No.	Application	Recommended oil	International specification	Quantity
1	Hydraulic oil	SAE 10W-30, API GL 4, ISO VG 32/46 (UTTO)	Multi grade, UTTO	System capacity - 107 L Tank capacity - 50 L
	Additional hydraulic oil for Bottom Dump Bucket	Same as machine	Same as machine	3.75 L
	Additional hydraulic oil for extendahoe			3.75 L
	Additional hydraulic oil for hammer			1.5 L
2	Transmission oil - 2WD	SAE 10W-30, API GL 4, ISO VG 32/46 (UTTO)	Multi grade, UTTO	18 L
	Transmission oil - 4WD	SAE 10W-30, API GL 4, ISO VG 32/46 (UTTO)	Multi grade, UTTO	20 L
3	Rear axle oil	SAE 20W-40; API GL 4	SAE 20W-40; API GL 4	* 17.1 L
4	4WD - Front axle oil (If equipped)	SAE 20W-40; API GL 4	SAE 20W-40; API GL 4	** 8.9 L
5	Fuel tank	Diesel	(-)	129 L
6	Fuel additive	FUEL ADDITIVE FOR FPT ENGINES	Fuel additive for FPT engines	250 mL
7	Engine oil	SAE 15W-40; API CI-4; ACEA E7	SAE 15W-40; API CI-4; ACEA E7	# 8.6 L
8	Engine coolant	OAT EXTENDED LIFE COOLANT ASTM D 3306 TYPE 1	OAT EG2, 50-50 Premix	20 L
9	Brake fluid	ISO 7308	ISO 7308	0.67 L
9	Grease – 2WD	NLGI 2, LITHIUM SOAP GREASE, EXTREME PRESSURE (EP), ANTI-WEAR	NLGI 2	2 kg
	Grease – 4WD			2.25 kg
10	Refrigerant	R134A	R134a	1.2 kg (2.6 lb)
11	Compressor oil	SP-15, VG 68	PAG 46	270 – 300 mL
12	Battery terminals	PETROLEUM JELLY	Petroleum jelly	0.01 kg

NOTE: * Out of **17.1 L** oil, **14.5 L** is used in differential and **1.3 L** is used in each hub.

NOTE: ** Out of **8.9 L** oil, **7.5 L** is used in differential and **0.7 L** is used in each hub.

NOTE: # **8.6 L** is consumed when engine oil filter is not changed. If engine oil filter is also changed, additional **0.5 L** oil is required.

NOTE: Diesel antifreeze should be added in the mentioned quantity in machines with cold start feature.



SERVICE MANUAL

Engine

**851FX Plus
851FX**

This as a preview PDF file from best-manuals.com



Download full PDF manual at best-manuals.com