

**CX250D**  
**CX250D Long Reach**  
Crawler Excavator

**SERVICE MANUAL**

Part number 47899898

English

June 2015

© 2015 CNH Industrial Italia S.p.A. All Rights Reserved.

**CASE**  
CONSTRUCTION



## **SERVICE MANUAL**

**CX250D Crawler excavators LC version (TIER4 FINAL) - MEA Market**  
**CX250D Long Reach Crawler excavators LC Long Reach (TIER4 FINAL) -**  
**MEA Market**

# Contents

---

## INTRODUCTION

Engine.....	10
[10.001] Engine and crankcase .....	10.1
[10.102] Pan and covers .....	10.2
[10.106] Valve drive and gears .....	10.3
[10.101] Cylinder heads .....	10.4
[10.105] Connecting rods and pistons.....	10.5
[10.103] Crankshaft and flywheel.....	10.6
[10.216] Fuel tanks .....	10.7
[10.206] Fuel filters .....	10.8
[10.218] Fuel injection system.....	10.9
[10.202] Air cleaners and lines .....	10.10
[10.250] Turbocharger and lines.....	10.11
[10.254] Intake and exhaust manifolds and muffler .....	10.12
[10.500] Selective Catalytic Reduction (SCR) exhaust treatment.....	10.13
[10.501] Exhaust Gas Recirculation (EGR) - Diesel Particulate Filter (DPF) exhaust treatment .....	10.14
[10.400] Engine cooling system .....	10.15
[10.414] Fan and drive .....	10.16
[10.310] Aftercooler.....	10.17
[10.304] Engine lubrication system.....	10.18
Hydraulic systems.....	35
[35.000] Hydraulic systems.....	35.1
[35.300] Reservoir, cooler, and filters.....	35.2
[35.106] Variable displacement pump .....	35.3
[35.102] Pump control valves.....	35.4
[35.359] Main control valve.....	35.5

[35.357] Pilot system .....	35.6
[35.355] Hydraulic hand control .....	35.7
[35.356] Hydraulic foot control.....	35.8
[35.352] Hydraulic swing system .....	35.9
[35.353] Hydraulic travel system .....	35.10
[35.354] Hydraulic central joint .....	35.11
[35.736] Boom hydraulic system .....	35.12
[35.737] Dipper hydraulic system.....	35.13
[35.738] Excavator and backhoe bucket hydraulic system.....	35.14
[35.360] Hammer and rotating bucket hydraulic system .....	35.15
<b>Frames and ballasting .....</b>	<b>39</b>
[39.140] Ballasts and supports .....	39.1
<b>Tracks and track suspension .....</b>	<b>48</b>
[48.130] Track frame and driving wheels.....	48.1
[48.100] Tracks .....	48.2
[48.134] Track tension units .....	48.3
[48.138] Track rollers .....	48.4
<b>Cab climate control .....</b>	<b>50</b>
[50.100] Heating .....	50.1
[50.200] Air conditioning.....	50.2
<b>Electrical systems .....</b>	<b>55</b>
[55.000] Electrical system .....	55.1
[55.100] Harnesses and connectors.....	55.2
[55.525] Cab engine controls.....	55.3
[55.015] Engine control system.....	55.4
[55.201] Engine starting system .....	55.5
[55.301] Alternator.....	55.6
[55.302] Battery.....	55.7

[55.202] Cold start aid .....	55.8
[55.011] Fuel tank system .....	55.9
[55.010] Fuel injection system .....	55.10
[55.014] Engine intake and exhaust system.....	55.11
[55.988] Selective Catalytic Reduction (SCR) electrical system .....	55.12
[55.989] Exhaust Gas Recirculation (EGR) electrical system .....	55.13
[55.012] Engine cooling system .....	55.14
[55.013] Engine oil system .....	55.15
[55.640] Electronic modules .....	55.16
[55.512] Cab controls.....	55.17
[55.036] Hydraulic system control .....	55.18
[55.051] Cab Heating, Ventilation, and Air-Conditioning (HVAC) controls.....	55.19
[55.050] Heating, Ventilation, and Air-Conditioning (HVAC) control system.....	55.20
[55.524] Cab controls (Lift arm, Boom, Dipper, Bucket).....	55.21
[55.416] Swing control system .....	55.22
[55.417] Travel control system .....	55.23
[55.530] Camera.....	55.24
[55.518] Wiper and washer system.....	55.25
[55.404] External lighting .....	55.26
[55.514] Cab lighting .....	55.27
[55.408] Warning indicators, alarms, and instruments .....	55.28
[55.992] Anti-theft system .....	55.29
[55.DTC] FAULT CODES.....	55.30
<b>Booms, dippers, and buckets .....</b>	<b>84</b>
[84.910] Boom .....	84.1
[84.912] Dipper arm .....	84.2
[84.100] Bucket.....	84.3
<b>Platform, cab, bodywork, and decals .....</b>	<b>90</b>
[90.150] Cab.....	90.1

[90.156] Cab glazing .....	90.2
[90.118] Protections and footboards.....	90.3
[90.120] Mechanically-adjusted operator seat.....	90.4
[90.100] Engine hood and panels .....	90.5





## **INTRODUCTION**



# Contents

---

## INTRODUCTION

Foreword - Important notice regarding equipment servicing .....	3
Safety rules .....	4
Safety rules – General information .....	5
Safety rules – Personal safety .....	6
Safety rules – ROPS judgment .....	8
Torque – Bolt and nut .....	12
Torque - Special torque setting .....	13
Basic instructions - Shop and assembly .....	17
General specification (*) .....	19
General specification (*) .....	24
General specification - Main equipment .....	28
Weight (*) .....	37
Weight (*) .....	40
Dimension (*) .....	42
Dimension (*) .....	45
Conversion factors .....	46
Consumables .....	58
Capacities .....	61
Abbreviation .....	62
Product identification .....	65
Product identification - Machine orientation .....	68

(\*) See content for specific models

---

## **Foreword - Important notice regarding equipment servicing**

All repair and maintenance work listed in this manual must be carried out only by qualified dealership personnel, strictly complying with the instructions given, and using, whenever possible, the special tools.

Anyone who performs repair and maintenance operations without complying with the procedures provided herein shall be responsible for any subsequent damages.

The manufacturer and all the organizations of its distribution chain, including - without limitation - national, regional, or local dealers, reject any responsibility for damages caused by parts and/or components not approved by the manufacturer, including those used for the servicing or repair of the product manufactured or marketed by the manufacturer. In any case, no warranty is given or attributed on the product manufactured or marketed by the manufacturer in case of damages caused by parts and/or components not approved by the manufacturer.

The manufacturer reserves the right to make improvements in design and changes in specifications at any time without notice and without incurring any obligation to install them on units previously sold. Specifications, descriptions, and illustrative material herein are as accurate as known at time of publication but are subject to change without notice.

In case of questions, refer to your CASE CONSTRUCTION Sales and Service Networks.

## Safety rules

### Personal safety





This is the safety alert symbol. It is used to alert you to potential personal injury hazards. Obey all safety messages that follow this symbol to avoid possible death or injury.

Throughout this manual you will find the signal words DANGER, WARNING, and CAUTION followed by special instructions. These precautions are intended for the personal safety of you and those working with you.

Read and understand all the safety messages in this manual before you operate or service the machine.

 DANGER indicates a hazardous situation that, if not avoided, will result in death or serious injury.

 WARNING indicates a hazardous situation that, if not avoided, could result in death or serious injury.

 CAUTION indicates a hazardous situation that, if not avoided, could result in minor or moderate injury.

**FAILURE TO FOLLOW DANGER, WARNING, AND CAUTION MESSAGES COULD RESULT IN DEATH OR SERIOUS INJURY.**

### Machine safety

**NOTICE:** Notice indicates a situation that, if not avoided, could result in machine or property damage.

Throughout this manual you will find the signal word Notice followed by special instructions to prevent machine or property damage. The word Notice is used to address practices not related to personal safety.

### Information

**NOTE:** Note indicates additional information that clarifies steps, procedures, or other information in this manual.

Throughout this manual you will find the word Note followed by additional information about a step, procedure, or other information in the manual. The word Note is not intended to address personal safety or property damage.

## **Safety rules – General information**

### **Cleaning**

Clean the metal parts with cleaning solution that meets the standard and steam cleaning. (except for bearings)

After cleaning, dry well, and inject oil in all parts.

Also inject oil into the bearings after drying.

### **Inspection**

When disassembling parts, check all the parts.

If there are any worn or damaged parts, replace them.

Inspect carefully to prevent initial breakdowns.

### **Bearing**

Replace any loose bearings.

Air dry bearings before installing them.

### **Needle bearing**

When inserting needle bearings, be very careful not to damage them.

Apply grease to the section where the needle bearing will be inserted.

### **Gear**

Check that there is no wear and no damage.

### **Oil seal, O-ring, gasket**

Always install new oil seals, O-rings, and gaskets.

Apply grease to sections where oil seals and O-rings will be inserted.

### **Shaft**

Check that there is no wear and no damage.

Check the bearings and check for damaged oil seals on the shaft.

### **Service parts**

Install CASE CONSTRUCTION genuine service parts.

When placing an order, check the parts catalog. It contains the CASE CONSTRUCTION genuine part numbers.

Any breakdowns arising from the installation of non-genuine parts are not covered by the warranty.

### **Lubricants (fuel, hydraulic oil)**

Use the oil from the specified company or specified in the operator's manual or service Manual.

Any breakdowns arising from any fuel or hydraulic oil other than those specified are not covered by the warranty.

## Safety rules – Personal safety

 **WARNING:**

This symbol indicates a precaution.  
It gives information concerning the safety of the operator and those in the surroundings.  
Read and understand these precautions thoroughly before performing the work.

Always comply with warnings and precautions so as to avoid any accidents.

This section covers information related to overall safety.

Check whether all warning labels are in place.

Additional labels can be ordered from Service Parts.

 **WARNING:**

Read the operator's manual to gain a thorough understanding of machine control operations.

 **WARNING:**

Perform any machine operations from the seating position.  
Any other method may cause severe injuries.

 **WARNING:**

Only the one operator is to ride on the machine. No one else is to ride on it.

 **WARNING:**

Check the safety messages in the operator's manual before starting the engine.  
Check all the warning labels on the machine.  
Check that no one is within the machine's operating range.  
Check the operating methods in a safe location before starting the actual work.  
Understand the machine operations well, then operate in compliance with all service-related laws and regulations.  
The operator's manual can be purchased at your CASE CONSTRUCTION dealer.

 **WARNING:**

Working with sloppy clothes or clothes with which safety cannot be ensured leads to damage to the machine and injury to the operator.  
Always wear clothes that ensures safety.  
In order to work more safely, it is recommended to wear additional safety equipment.  
Helmet, safety shoes, ear protection, goggles, work clothes, and gloves

 **WARNING:**

Pay careful attention when working with the engine running.

 **WARNING:**

Check hydraulic equipment.  
Work according to the procedure.  
Do not change the procedure.

## INTRODUCTION

 WARNING:

Check that there is no one in the surroundings before draining the pressure from hydraulic circuits during machine hydraulic cylinder inspection.

 WARNING:

Use gloves when handling high-temperature parts.

 WARNING:

Bring the lower parts or attachments in contact with the ground before inspecting or repairing them.

 WARNING:

Check that hoses and tubes are securely connected.  
If there is any damage to a hose or tube, replace it.  
Do not check for oil leaks by hand. Use cardboard or wood.

 WARNING:

When removing an attachment pin or other hardened pin, use a hammer that has a soft head.

 WARNING:

Wear eye protection when using a hammer to install a pin or when working with a grinder.  
At this time, use goggles or eye protectors that meet standards.

 WARNING:

Park the machine in a safe location when repairing or inspecting it.

 WARNING:

Use work site protection when repairing the machine.  
Check the oil, coolant, grease, and tools.  
Recover materials and parts as necessary.  
Pay enough attention to safety.

 WARNING:

Some of the machine's parts are extremely heavy.  
Use an appropriate lifting equipment for such parts.  
For weights and procedures, see the Service Manual.

 WARNING:

Exhaust gases are toxic.  
Always provide good ventilation when working indoors or in any other enclosed space.

 WARNING:

If the electrolytic battery solution freezes, it may explode.

## Safety rules – ROPS judgment

### 1. Purpose

Judge whether or not the model is compliant with ROPS by the ROPS criteria.

Compliance with ROPS is highly dependent on its deadweight and boom.

The model has passed the ROPS test for its deadweight with all selectable options installed (as of 2014).

However, the judgment is required because its deadweight or boom position may go beyond the assumption depending on derivative or order conditions.

### 2. ROPS criteria

#### Weight

For each class, the following weight shall not be exceeded.

If the weight is exceeded, a cab may become damaged in case of a rollover, causing the operator to die or become severely disabled.

It is not applicable beyond the criterion.

The ROPS-compliant model shall not exceed the weight shown in the table.

(The following weight is shown on the decal in the ROPS cab.)

Gross body weight	Class
20500 kg (45194.76 lb) or less	CX130D
	CX160D
	CX180D
32000 kg (70547.92 lb) or less	CX210D
	CX250D
	CX300D
40000 kg (88184.90 lb) or less	CX350D
	CX370D

#### Boom position

##### Warning

- If you make such modification as lowers the boom position, ROPS is not applicable.
- Consultation with us is required whenever it is assumed that the boom position is lowered by modification.
- The range of change in the boom position cannot be determined uniformly.

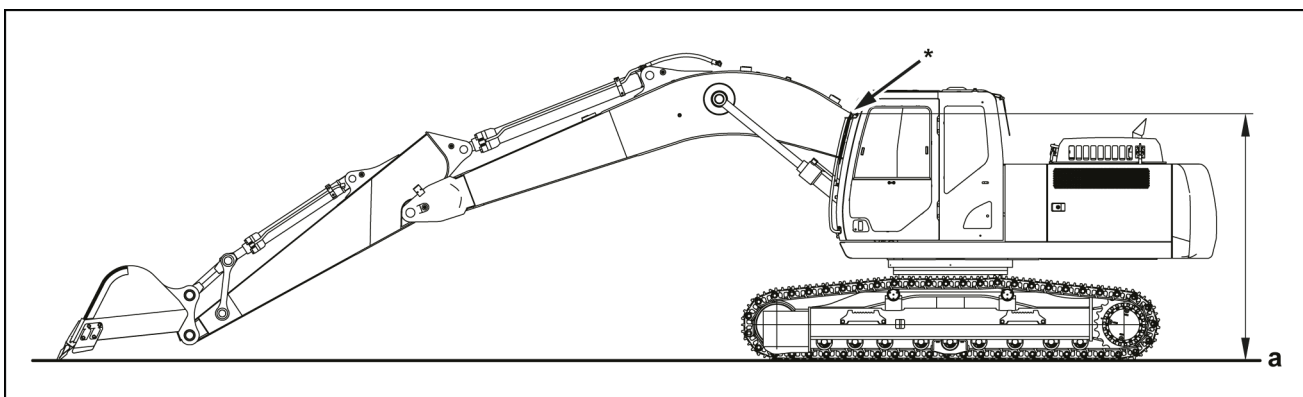

SMIL14CEX2001EA 1

(a) Ground point

It is not applicable if the position overlapping with a cab on the side view (mark \* in the figure) is lowered significantly as compared with the standard model (standard arm), within the maximum digging radius with the bucket tip on the surface of the ground.

Moreover, it cannot be said that the 24-ton model, close to the limit weight, with a cab that can bear up to 31-tons and the 21-ton model with the same cab are the same in the degree of influence.

### 3. Prohibitions

- Such modification as reduces the strength of the platform where the ROPS cab is installed. (Such action or modification as reduces the function of the retaining anchor in the left rear of the cab)
- Such modification as affects the ROPS strength of the ROPS cab.

Modification prohibited (Red components)	All changes (grinding, welding, drilling, removal, etc.) are prohibited.
Conditional modification permitted (Gray components)	Removal of components is prohibited. Welding and drilling of bars (limited to <b>20 mm (0.79 in)</b> or less in diameter) are allowed.

### Cab (CX130D/CX160D/CX180D)

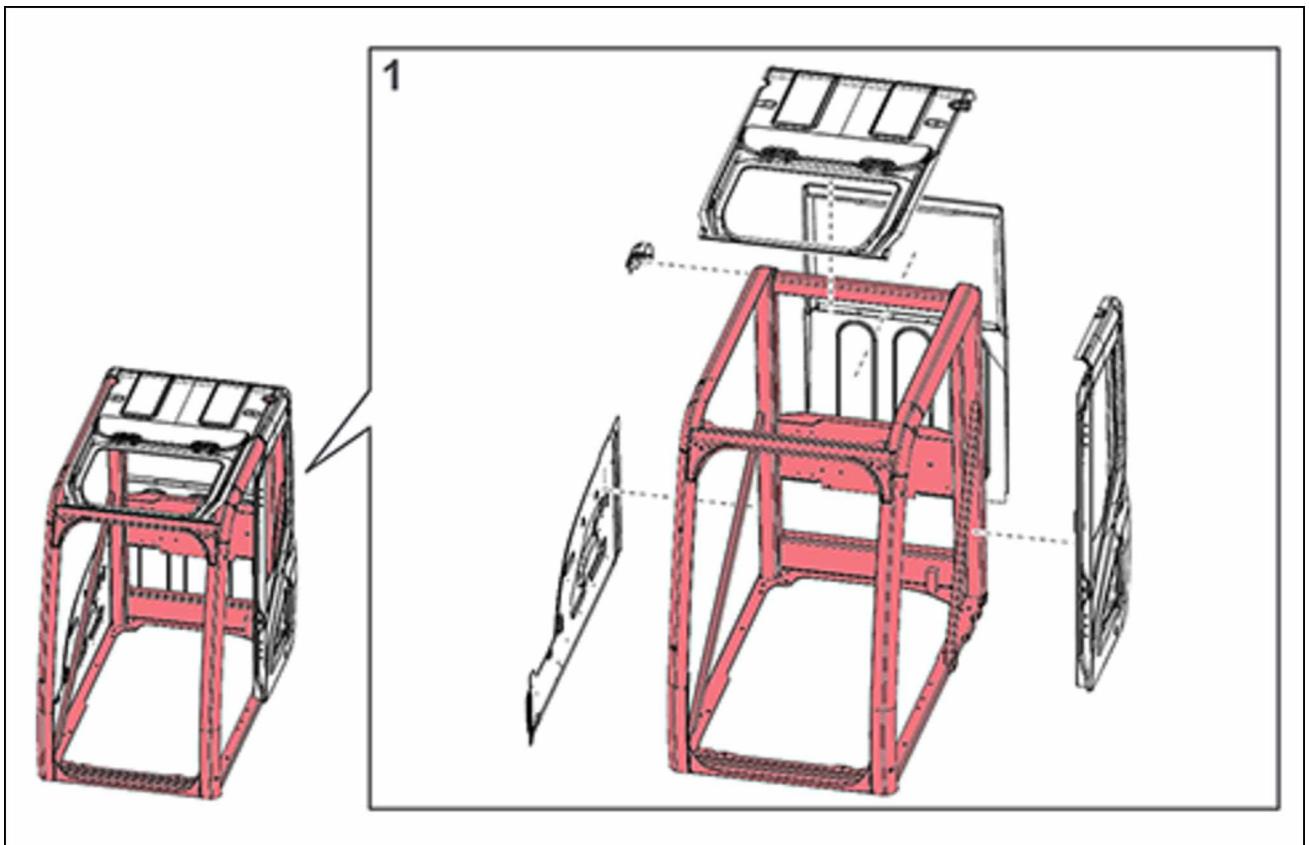

SMPH15CEX5805FA 2



**Cab (CX210D/CX250D/CX300D)**

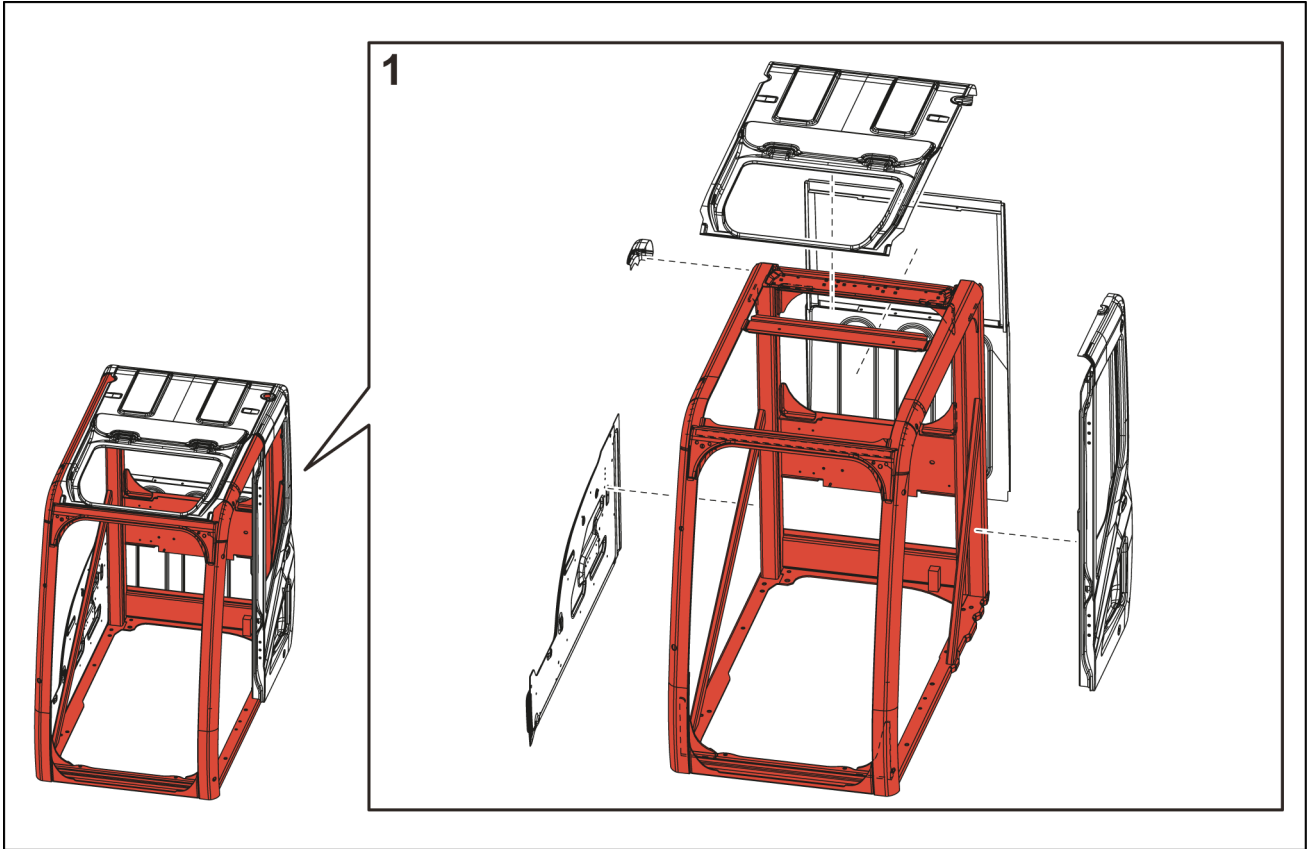

SMIL14CEX2002FA 3

## Cab (CX350D/CX370D)

The large-sized model (CX350D/CX370D) cab consists of the medium-sized model (CX210D/CX250D/CX300D) cab in the figure plus seven reinforcements.

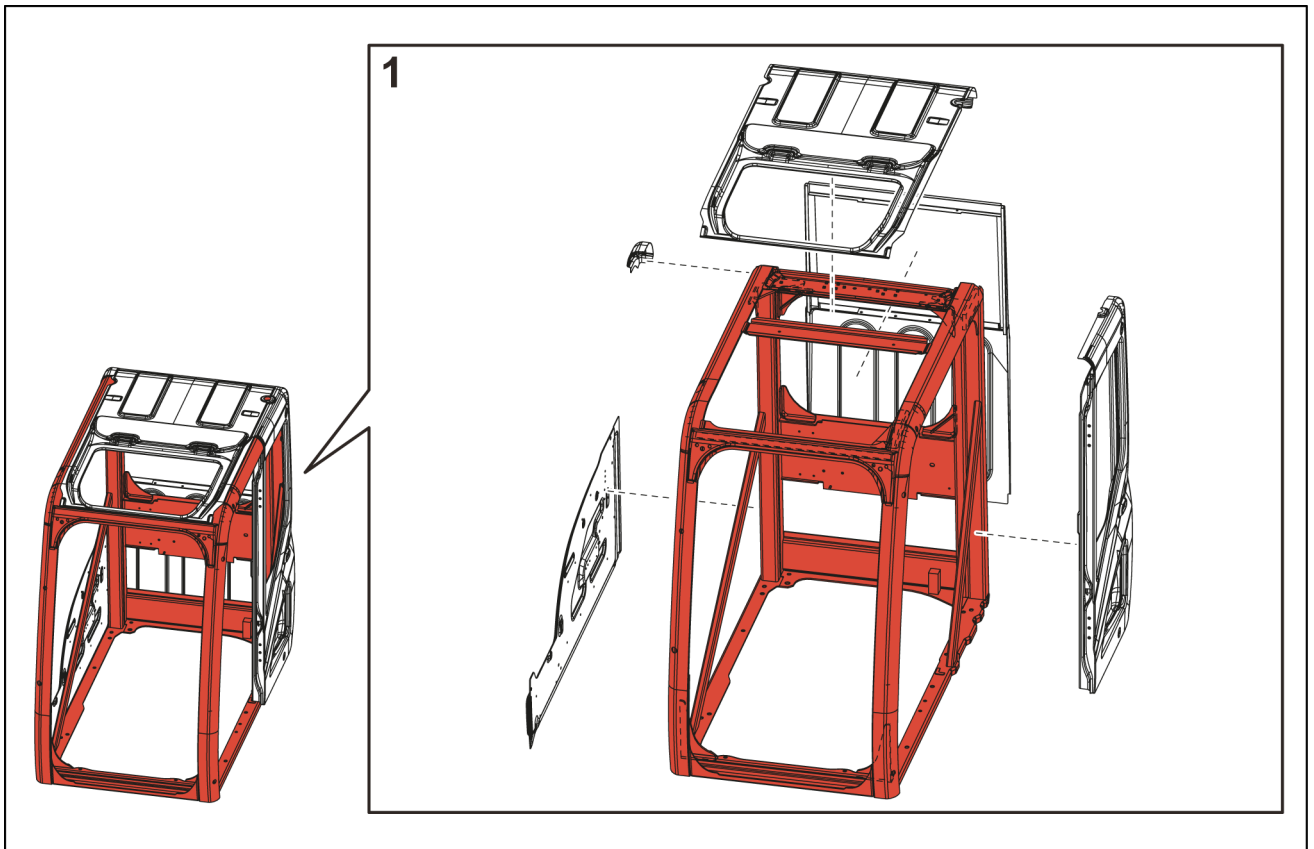

SMIL14CEX2003FA 4

The high cab is not supported basically. (Since it varies for each model, consultation with us is required in each case.)

## Torque – Bolt and nut

- Tighten alternating between left and right and top and bottom so that uniform tightening force is applied.

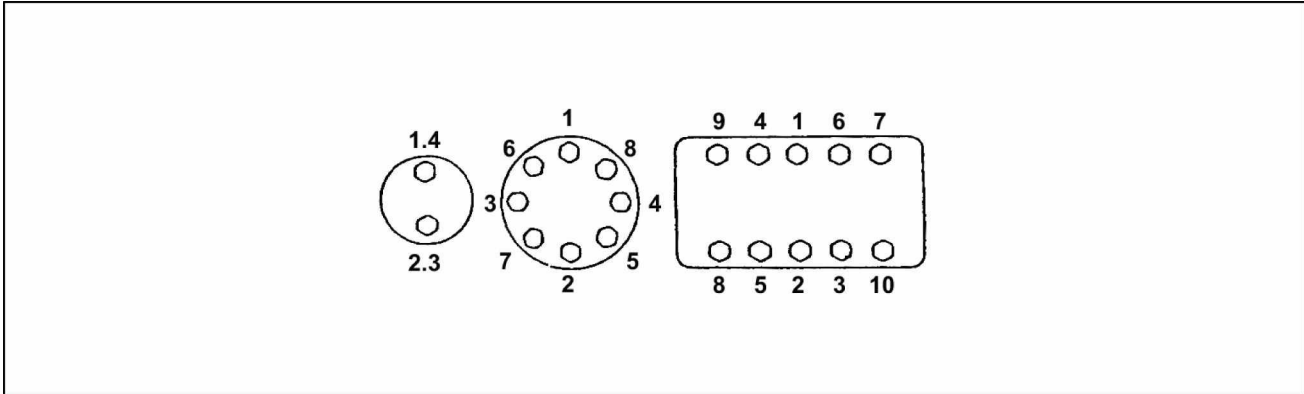

LPIL12CX00005EA 1

- If **LOCTITE®** was used on a removed bolt (there is something white sticking to the bolt when it is removed), clean the old **LOCTITE®** off with cleaning fluid, dry the bolt, then apply 2 - 3 drops of **LOCTITE®** to the thread section of the bolt.

### Torque table

Bolt nominal diameter (size)		M6	M8	M10	M12	M14	M16	M18	M20
Hexagon bolt	Wrench	10 mm	13 mm	17 mm	19 mm	22 mm	24 mm	27 mm	30 mm
	Tightening torque	6.9 N·m (5.089 lb ft)	19.6 N·m (14.456 lb ft)	39.2 N·m (28.912 lb ft)	58.8 N·m (43.369 lb ft)	98.1 N·m (72.355 lb ft)	156.9 N·m (115.72 m (144.63 3 lb ft)	196.1 N·m (144.63 6 lb ft)	294.2 N·m (216.99 1 lb ft)
Hexagon socket head bolt	Wrench	5 mm	6 mm	8 mm	10 mm	12 mm	14 mm	14 mm	17 mm
	Tightening torque	8.8 N·m (6.491 lb ft)	21.6 N·m (15.931 lb ft)	42.1 N·m (31.051 lb ft)	78.5 N·m (57.899 lb ft)	117.7 N·m (86.811 lb ft)	176.5 N·m (130.18 0 lb ft)	245.2 N·m (180.85 0 lb ft)	343.2 N·m (253.13 1 lb ft)

## Torque - Special torque setting

Code	Retightening location		Bolt nominal diameter	Wrench	Tightening torque
1*	Travel motor		M16	24 mm	267 - 312 N·m (196.93 - 230.12 lb ft)
2*	Drive sprocket		M16	24 mm	267 - 312 N·m (196.93 - 230.12 lb ft)
3*	Take-up roller		M16	24 mm	267 - 312 N·m (196.93 - 230.12 lb ft)
4*	Upper roller		M20	30 mm	521 - 608 N·m (384.27 - 448.44 lb ft)
5*	Lower roller		M18	27 mm	371 - 432 N·m (273.64 - 318.63 lb ft)
6*	Track guard		M18	27 mm	400 - 462 N·m (295.02 - 340.75 lb ft)
7	Shoe		M20	30 mm	250 - 350 N·m (184.39 - 258.15 lb ft)
8	Counterweight		M33	50 mm	1950 - 2156 N·m (1438.25 - 1590.18 lb ft)
9*	Turntable bearing		M24	36 mm	784 - 914 N·m (578.25 - 674.13 lb ft)
10*	Swing unit		M24	36 mm	784 - 914 N·m (578.25 - 674.13 lb ft)
11*	Engine	Mount	M16	24 mm	264.9 - 313.9 N·m (195.38 - 231.52 lb ft)
12*		Front bracket	M10	17 mm	63.8 - 73.6 N·m (47.06 - 54.28 lb ft)
13*		Rear bracket	M16	24 mm	205.9 - 247.1 N·m (151.86 - 182.25 lb ft)
14*	Radiator		M16	24 mm	147.2 - 176.6 N·m (108.57 - 130.25 lb ft)
15*	Hydraulic pump	Pump	M20	17 mm hexagon socket head	367 - 496 N·m (270.69 - 365.83 lb ft)
16*	Hydraulic oil tank		M16	24 mm	232.4 - 276 N·m (171.41 - 203.57 lb ft)
17*	Fuel tank		M16	24 mm	232.4 - 276 N·m (171.41 - 203.57 lb ft)
18*	Control valve		M16	24 mm	267 - 312 N·m (196.93 - 230.12 lb ft)
19*	Center	Lock bar	M12	19 mm	88.3 - 107 N·m (65.13 - 78.92 lb ft)
20*	Joint	Joint	M12	19 mm	109 - 127 N·m (80.39 - 93.67 lb ft)
21	Cab		M16	24 mm	149 - 173 N·m (109.90 - 127.60 lb ft)
22	Battery		M10	17 mm	19.6 - 29.4 N·m (14.46 - 21.68 lb ft)

 CAUTION:

- Make sure to apply **LOCTITE® 262™** or equivalent to the locations with the \* mark, and tighten according to the specified torque.
- Tightening torque:  $N \cdot m \div 9.8 = kgf \cdot m$

INTRODUCTION

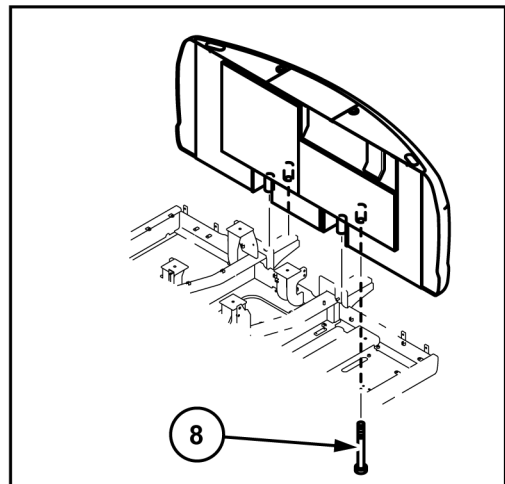
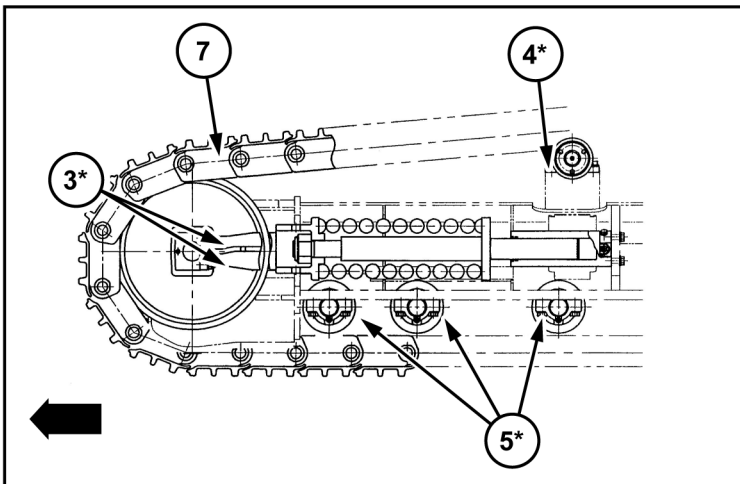
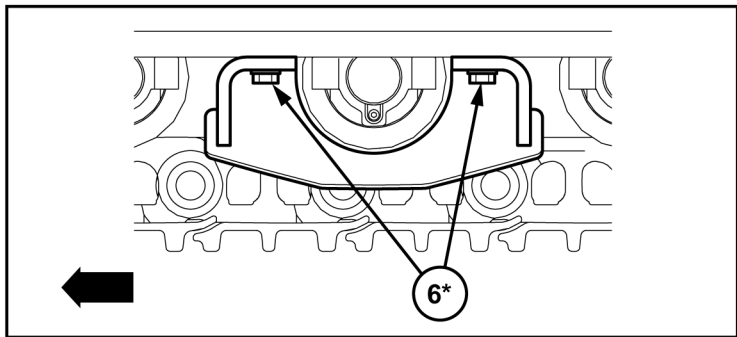
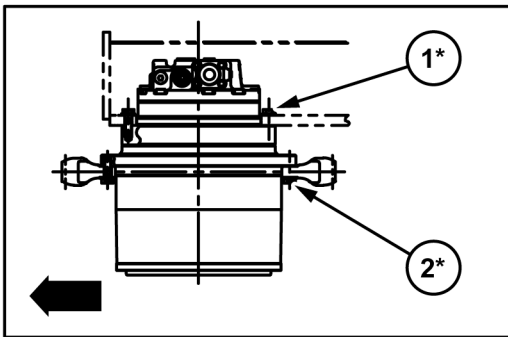
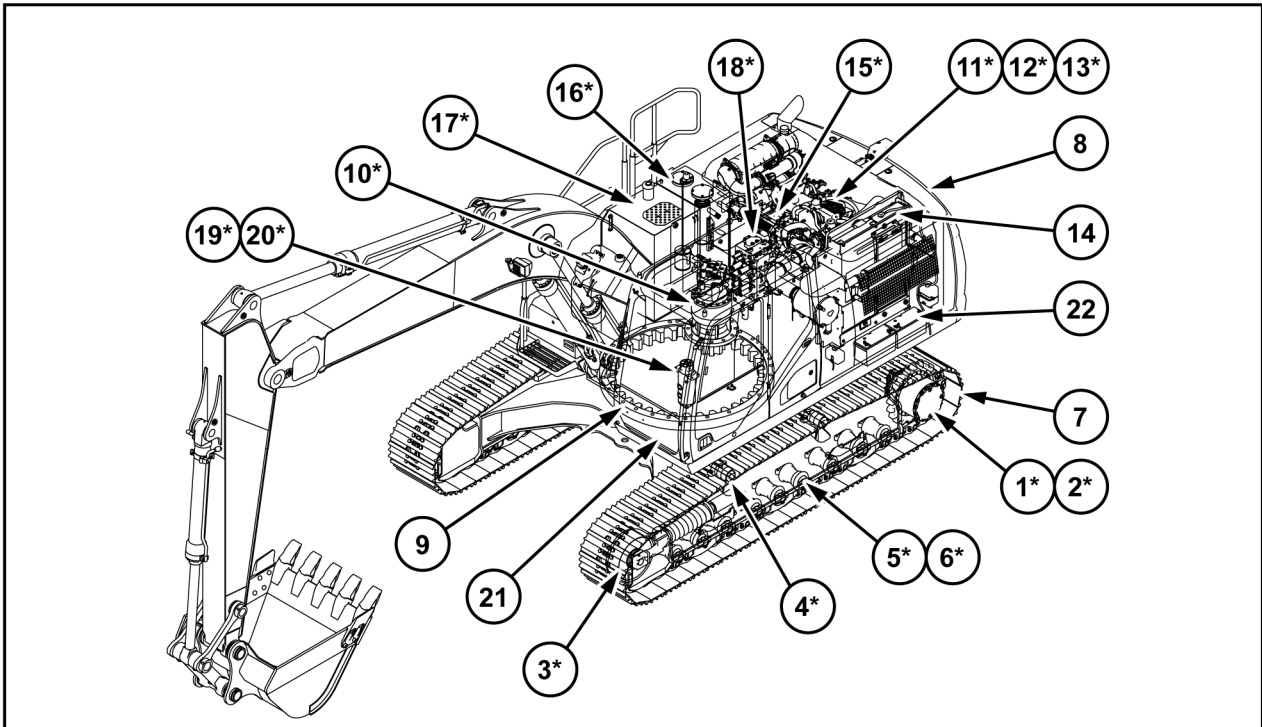

SMIL14CEX6655HB 1

# INTRODUCTION

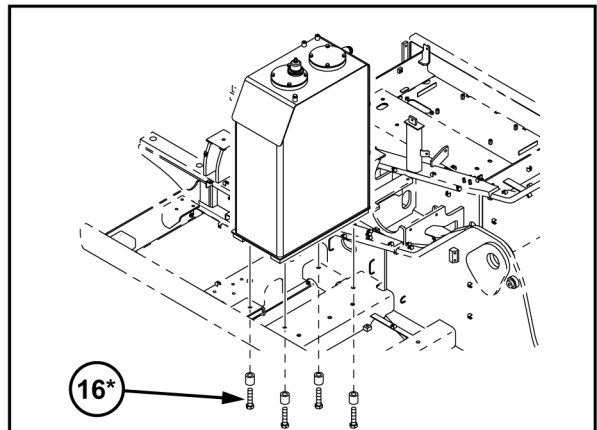
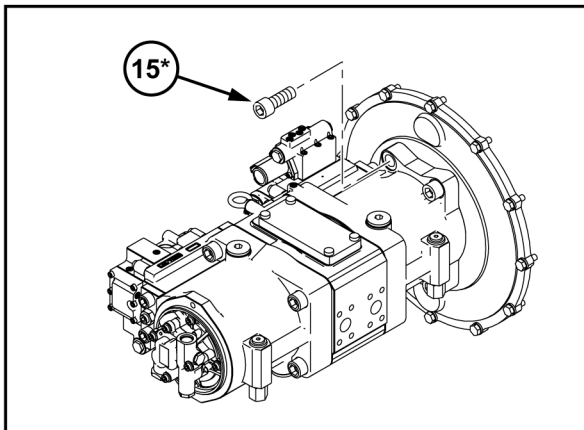
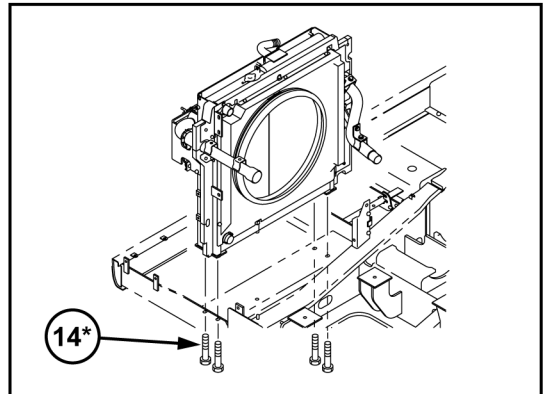
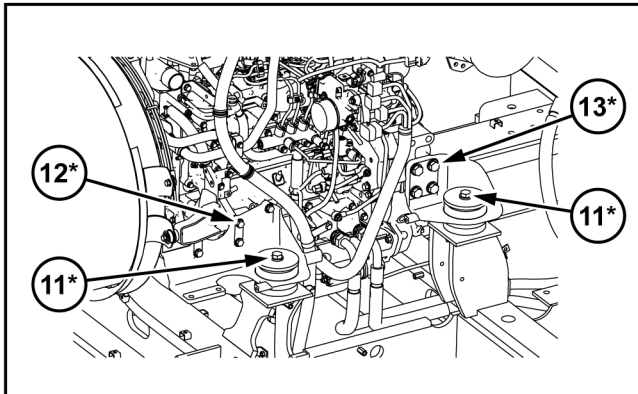
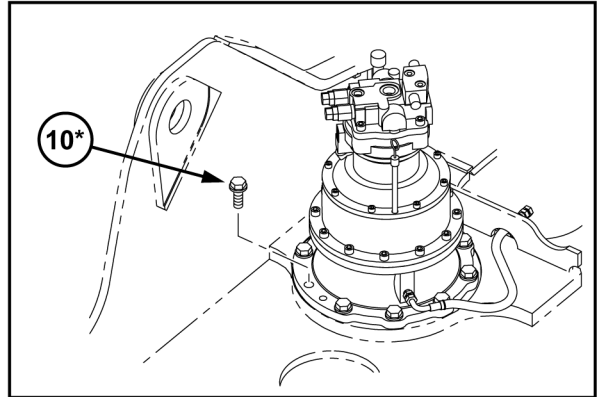
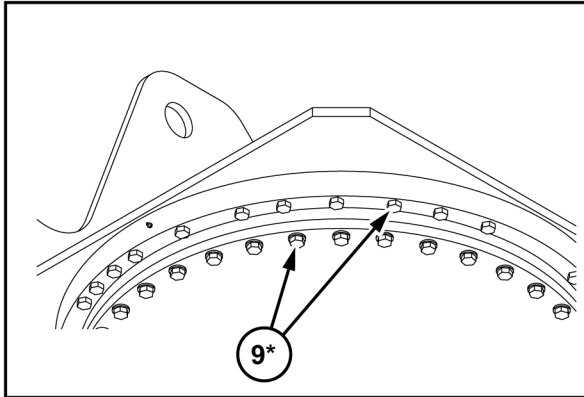

SML14CEX6657GB 2

INTRODUCTION

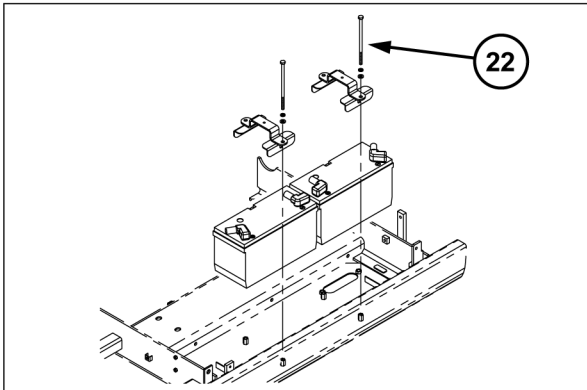
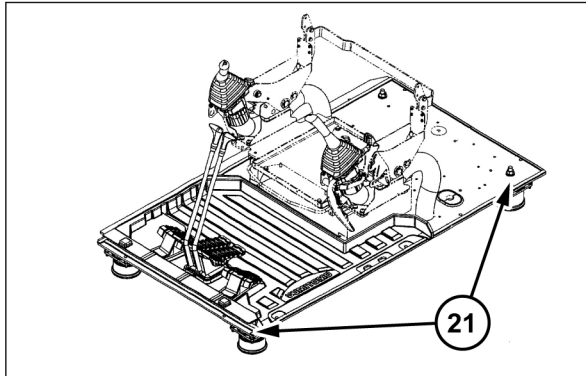
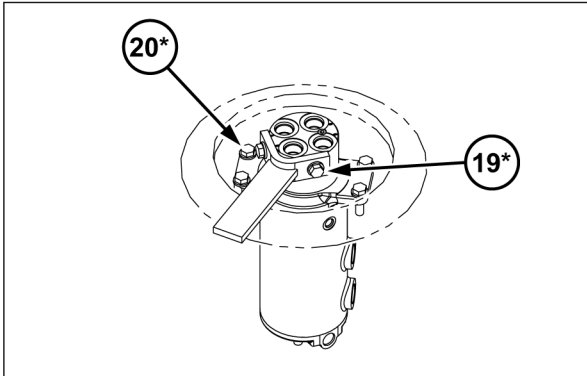
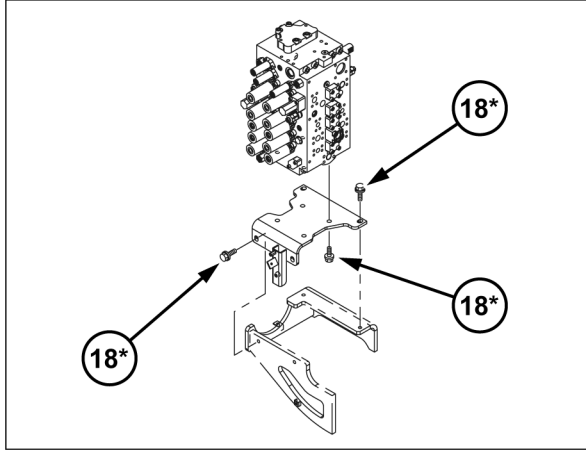
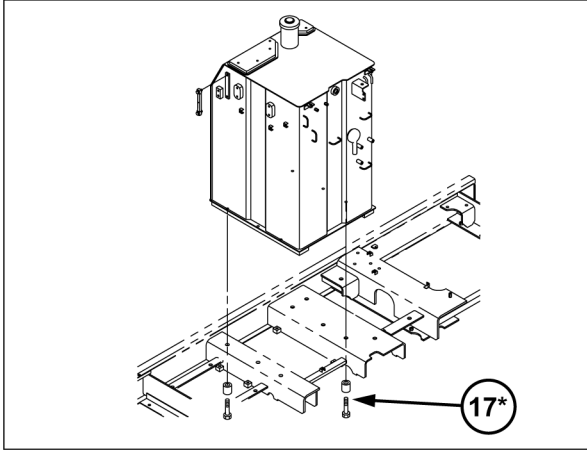

SMIL14CEX6656GB 3

---

## Basic instructions - Shop and assembly

### Shimming

For each adjustment operation, select adjusting shims and measure the adjusting shims individually using a micrometer, then add up the recorded values. Do not rely on measuring the entire shimming set, which may be incorrect, or the rated value shown on each shim.

### Rotating shaft seals

For correct rotating shaft seal installation, proceed as follows:

1. Before assembly, allow the seal to soak in the oil it will be sealing for at least thirty minutes.
2. Thoroughly clean the shaft and check that the working surface on the shaft is not damaged.
3. Position the sealing lip facing the fluid.

**NOTE:** *With hydrodynamic lips, take into consideration the shaft rotation direction and position the grooves so that they will move the fluid towards the inner side of the seal.*

4. Coat the sealing lip with a thin layer of lubricant (use oil rather than grease). Fill the gap between the sealing lip and the dust lip on double lip seals with grease.
5. Insert the seal in its seat and press down using a flat punch or seal installation tool. Do not tap the seal with a hammer or mallet.
6. While you insert the seal, check that the seal is perpendicular to the seat. When the seal settles, make sure that the seal makes contact with the thrust element, if required.
7. To prevent damage to the seal lip on the shaft, position a protective guard during installation operations.

### O-ring seals

Lubricate the O-ring seals before you insert them in the seats. This will prevent the O-ring seals from overturning and twisting, which would jeopardize sealing efficiency.

### Sealing compounds

Apply a sealing compound on the mating surfaces when specified by the procedure. Before you apply the sealing compound, prepare the surfaces as directed by the product container.

### Spare parts

Only use CNH Original Parts or CASE CONSTRUCTION Original Parts.

Only genuine spare parts guarantee the same quality, duration, and safety as original parts, as they are the same parts that are assembled during standard production. Only CNH Original Parts or CASE CONSTRUCTION Original Parts can offer this guarantee.

When ordering spare parts, always provide the following information:

- Machine model (commercial name) and Product Identification Number (PIN)
- Part number of the ordered part, which can be found in the parts catalog



---

## Protecting the electronic and/or electrical systems during charging and welding

To avoid damage to the electronic and/or electrical systems, always observe the following practices:

1. Never make or break any of the charging circuit connections when the engine is running, including the battery connections.
2. Never short any of the charging components to ground.
3. Always disconnect the ground cable from the battery before arc welding on the machine or on any machine attachment.
  - Position the welder ground clamp as close to the welding area as possible.
  - If you weld in close proximity to a computer module, then you should remove the module from the machine.
  - Never allow welding cables to lie on, near, or across any electrical wiring or electronic component while you weld.
4. Always disconnect the negative cable from the battery when charging the battery in the machine with a battery charger.

**NOTICE:** *If you must weld on the unit, you must disconnect the battery ground cable from the machine battery. The electronic monitoring system and charging system will be damaged if this is not done.*

5. Remove the battery ground cable. Reconnect the cable when you complete welding.

### **⚠ WARNING**

**Battery acid causes burns. Batteries contain sulfuric acid.**

**Avoid contact with skin, eyes or clothing. Antidote (external): Flush with water. Antidote (eyes): flush with water for 15 minutes and seek medical attention immediately. Antidote (internal): Drink large quantities of water or milk. Do not induce vomiting. Seek medical attention immediately.**

**Failure to comply could result in death or serious injury.**

W0111A

## Special tools

The special tools that CASE CONSTRUCTION suggests and illustrate in this manual have been specifically researched and designed for use with CASE CONSTRUCTION machines. The special tools are essential for reliable repair operations. The special tools are accurately built and rigorously tested to offer efficient and long-lasting operation.

By using these tools, repair personnel will benefit from:

- Operating in optimal technical conditions
- Obtaining the best results
- Saving time and effort
- Working in safe conditions

## General specification

CX250D Crawler excavators LC version (TIER4 FINAL) - MEA Market	MEA
---	-----

### Engine

Type	Water-cooled, 4-cycle diesel, 4-cylinder in line, High pressure common rail system (electric control), Turbocharger with air cooled intercooler, SCR system	
Model	ISUZU AQ-4HK1X	
Rated flywheel horse power		
	<b>SAE J1349, ISO 9249</b>	<b>132.1 kW (180 Hp) at 2000 RPM</b>
	<b>ISO 14396</b>	<b>140 kW (190 Hp) at 2000 RPM</b>
Piston displacement	<b>5193 cm<sup>3</sup> (317 in<sup>3</sup>)</b>	
Maximum torque		
	<b>SAE J1349, ISO 9249</b>	<b>621 N·m (458 lb ft) at 1800 RPM</b>
	<b>ISO 14396</b>	<b>642 N·m (474 lb ft) at 1800 RPM</b>
Bore and stroke	<b>115 - 125 mm (4.53 - 4.92 in)</b>	
Voltage	<b>24 V</b>	
Alternator	<b>50 A</b>	
Starter	<b>24 V 5.0 kW</b>	

### Hydraulic system

Main pumps	2 variable displacement axial piston pumps with regulating system	
	Max. oil flow	<b>2 × 234 L (61.8 US gal) at 2000 RPM</b>
	Working circuit pressure	Boom/Arm/Bucket <b>34.3 MPa (4975 psi)</b>
		Swing circuit <b>28.9 MPa (4192 psi)</b>
		Travel circuit <b>34.3 MPa (4975 psi)</b>
Pilot pump	1 gear pump	
	Max. oil flow	<b>20 L (5.3 US gal)</b>
	Working circuit pressure	<b>3.9 MPa (566 psi)</b>
Control valves	With Boom/Arm holding valve	
	One 4-spool valve for Right track travel, Bucket, Boom and Arm acceleration	
	One 5-spool valve for Left track travel, Auxiliary, Swing, Boom acceleration and Arm	
Swing device		
	Motor	Fixed displacement axial piston motor
	Brake	Mechanical disc brake
	Final drive	Planetary gear reduction
	Turn table bearing	Ball bearing type with internal gear
	Maximum swing speed	<b>10.6 RPM</b>
	Swing torque	<b>74900 N·m (55243 lb ft)</b>
Cylinders	NO. of cylinders – bore X Rod diameter X Stroke	
	Boom	<b>2 x Ø 130 mm (5.118 in) - Ø 90 mm (3.543 in) - 1335 mm (52.559 in)</b>
	Arm	<b>1 x Ø 145 mm (5.709 in) - Ø 105 mm (4.134 in) - 1660 mm (65.354 in)</b>
	Bucket	<b>1 x Ø 130 mm (5.118 in) - Ø 90 mm (3.543 in) - 1070 mm (42.126 in)</b>
Cooling system		
	Fan	<b>Ø 650 mm (25.6 in) with 7-blades</b>
	Radiator capacity	<b>105.9 kW</b>
		fin type Corrugated fin (wavy type)
		fin space <b>1.75 mm (0.06890 in)</b>
	Long life coolant	Coolant 55 % , Water 45 %

## INTRODUCTION

Oil cooler capacity		<b>54.1 kW</b>
	fin type	Corrugated fin (wavy type)
	fin space	<b>1.75 mm (0.06890 in)</b>
Intercooler capacity		<b>16.7 kW</b>
	fin type	Straight fin
	fin space	<b>1.75 mm (0.06890 in)</b>
Fuel cooler capacity		<b>1.3 kW</b>
	fin type	Corrugated fin (wavy type)
	fin space	<b>2.0 mm (0.0787 in)</b>
Filters		
	Suction filter	105 µm
	Return filter	6 µm
	Pilot line filter	8 µm

### Hydraulic controls

Boom/Arm/Bucket/Swing	Pilot pressure control system (ISO control pattern)
Travel	Pilot pressure control system
Work mode select	SP - mode
	H - mode
	Auto - mode
Travel mode select	2-speed travel
Attachment cushion control	
Hydraulic lock (gate lock, left side tilt console)	

### Electrical system

Engine control		
	Dial type throttle control	
	One touch idle / Auto deceleration / Auto idle shutdown system	
	Emergency stop	
Monitor system		
	Message display (Caution, condition, etc.)	
	Work mode display (SP, H, Auto)	
	Machine condition (Power boost, etc.)	
	Alarm display and buzzer	
	Water temperature	
	Hydraulic oil temperature	
	Fuel level	
	Diagnosis system	
	Rear view camera image	
	Urea water level	
Wire harness		
	Waterproof type connector	
Safety		
	Double horn	
Battery		
	2 X 12 V 92 A·h/5HR	
Lights		
Working light	Upper	24 V 70 W X 1
	Boom	24 V 70 W X 1
	Cab	24 V 70 W X 2
Operator's cab room		24 V 70 W X 1

## Operator environment

Operator's cab		
	Smooth and round shape design cab, fabricated by press work	
	Safety glass for all windows	
	Shock-less cab suspension by 4-point fluid mounting	
	Sliding front window with auto lock	
	Built-in type full-color LCD monitor display	
	Membrane switch on monitor display	
	Windshield wiper & washer	
	Floor mat	
	Polycarbonate roof hatch & Sun shade	
	Auto air-conditioner	
	Rain deflector	
	Sun visor	
	Roll-over protective structure (ROPS)	
	Top guard OPG level 1 (in CAB structure)	
	Top guard OPG level 2 (additional guard)	
Operator's seat		
	Low frequency air suspension with air springs and double acting hydraulic damper. (Achieves ISO7096 in category EM6)	
	With following features	
	Manual weight adjustment	Backrest angle adjustment
	Seat height adjustment	Adjustable pivoting armrests linked to consoles
	Adjustable headrest	Retractable seat belt
	Adjustable lumbar support	Control consoles adjust independently of seat
Others		
	Rear view mirror (Cab side & Right side)	
	Rear view Camera	

## Undercarriage

Travel motor		Variable displacement axial piston motor
Brake		Mechanical disc brake
Hydraulic service brake		Brake valve
Final drive		Planetary gear reduction
Travel speeds	High	<b>5.5 km/h (3.4 mph)</b> (Automatic travel speed shifting)
	Low	<b>3.5 km/h (2.2 mph)</b>
Drawbar pull		<b>200 kN (44962 lb)</b>
Number of carrier rollers (each side)		2
Number of track rollers (each side)		9
Number of shoes (each side)		51
Type of shoe		Triple grouser shoe
Link pitch		<b>190 mm (7.480 in)</b>
Width of shoe		<b>600 mm (23.622 in)</b> (S.T.D)
Grade-ability		<b>70 % ( 35 ° )</b>

**Mass**

Operating mass	<b>25400 kg (55997 lb)</b>
with <b>3.00 m (9.8425 ft)</b> Arm, <b>1.1 m<sup>3</sup></b> Bucket, <b>600 mm (23.622 in)</b> grouser shoe, operator, lubricant, coolant, full fuel tank, and top guard OPG level 2	
Shipping mass	<b>24200 kg (53352 lb)</b>
Operating mass - (operator mass [ <b>75 kg (165.35 lb)</b> ] + <b>90 %</b> of fuel mass + bucket mass [ <b>810 kg (1785.74 lb)</b> ]	
Counter weight mass	<b>5220 kg (11508 lb)</b>
Ground pressure	<b>0.038 MPa (5.512 psi)</b>
with <b>3.00 m (9.8425 ft)</b> Arm, <b>1.1 m<sup>3</sup></b> Bucket, <b>600 mm (23.622 in)</b> grouser shoe	

**Digging force (with 1.1 m<sup>3</sup> bucket) ( ISO 6015 )**

	<b>3.00 m (9.8425 ft) Arm</b>	<b>2.50 m (8.2021 ft) Arm</b>	<b>3.52 m (11.5486 ft) Arm</b>
Arm digging force	<b>120 kN (26977 lb)</b>	<b>141 kN (31698 lb)</b>	<b>107 kN (24055 lb)</b>
With auto power up	<b>130 kN (29225 lb)</b>	<b>153 kN (34396 lb)</b>	<b>116 kN (26078 lb)</b>
Bucket digging force	<b>162 kN (36419 lb)</b>	<b>162 kN (36419 lb)</b>	<b>162 kN (36419 lb)</b>
With auto power up	<b>176 kN (39566 lb)</b>	<b>176 kN (39566 lb)</b>	<b>176 kN (39566 lb)</b>

**Dimensions**

	<b>3.00 m (9.8425 ft) Arm</b>	<b>2.50 m (8.2021 ft) Arm</b>	<b>3.52 m (11.5486 ft) Arm</b>
Overall length (without attachment)	<b>5270 mm (207.480 in)</b>	<b>5270 mm (207.480 in)</b>	<b>5270 mm (207.480 in)</b>
Overall length (with attachment)	<b>9880 mm (388.976 in)</b>	<b>9950 mm (391.732 in)</b>	<b>9910 mm (390.157 in)</b>
Overall height (to top of boom)	<b>3200 mm (125.984 in)</b>	<b>3350 mm (131.890 in)</b>	<b>3360 mm (132.283 in)</b>
Overall height (to top of Cab)	<b>3130 mm (123.228 in)</b>	<b>3130 mm (123.228 in)</b>	<b>3130 mm (123.228 in)</b>
Overall height (to top of guardrail)	<b>3340 mm (131.496 in)</b>	<b>3340 mm (131.496 in)</b>	<b>3340 mm (131.496 in)</b>
Upper structure overall width	<b>2770 mm (109.055 in)</b>	<b>2770 mm (109.055 in)</b>	<b>2770 mm (109.055 in)</b>
Swing (rear end) radius	<b>2950 mm (116.142 in)</b>	<b>2950 mm (116.142 in)</b>	<b>2950 mm (116.142 in)</b>
Clearance height under upper structure	<b>1100 mm (43.307 in)</b>	<b>1100 mm (43.307 in)</b>	<b>1100 mm (43.307 in)</b>
Minimum ground clearance	<b>440 mm (17.323 in)</b>	<b>440 mm (17.323 in)</b>	<b>440 mm (17.323 in)</b>
Wheel base (Center to center of wheels)	<b>3840 mm (151.181 in)</b>	<b>3840 mm (151.181 in)</b>	<b>3840 mm (151.181 in)</b>
Crawler overall length	<b>4650 mm (183.071 in)</b>	<b>4650 mm (183.071 in)</b>	<b>4650 mm (183.071 in)</b>
Track gauge	<b>2590 mm (101.969 in)</b>	<b>2590 mm (101.969 in)</b>	<b>2590 mm (101.969 in)</b>
Undercarriage overall width [with <b>600 mm (23.622 in)</b> shoes]	<b>3190 mm (125.591 in)</b>	<b>3190 mm (125.591 in)</b>	<b>3190 mm (125.591 in)</b>
Crawler tracks height	<b>940 mm (37.008 in)</b>	<b>940 mm (37.008 in)</b>	<b>940 mm (37.008 in)</b>

**Working ranges**

	<b>3.00 m (9.8425 ft) Arm</b>	<b>2.50 m (8.2021 ft) Arm</b>	<b>3.52 m (11.5486 ft) Arm</b>
Boom length	<b>5850 mm (230.315 in)</b>	<b>5850 mm (230.315 in)</b>	<b>5850 mm (230.315 in)</b>
Bucket radius	<b>1570 mm (61.811 in)</b>	<b>1570 mm (61.811 in)</b>	<b>1570 mm (61.811 in)</b>
Bucket wrist action	<b>175 °</b>	<b>175 °</b>	<b>175 °</b>
Maximum reach at GRP	<b>10100 mm (397.638 in)</b>	<b>9630 mm (379.134 in)</b>	<b>10620 mm (418.110 in)</b>
Maximum reach	<b>10280 mm (404.724 in)</b>	<b>9820 mm (386.614 in)</b>	<b>10790 mm (424.803 in)</b>
Max. digging depth	<b>6900 mm (271.654 in)</b>	<b>6400 mm (251.969 in)</b>	<b>7420 mm (292.126 in)</b>
Max. digging height	<b>9760 mm (384.252 in)</b>	<b>9560 mm (376.378 in)</b>	<b>10070 mm (396.457 in)</b>
Max. dumping height	<b>6760 mm (266.142 in)</b>	<b>6550 mm (257.874 in)</b>	<b>7060 mm (277.953 in)</b>

## General specification

CX250D Long Reach Crawler excavators LC Long Reach (TIER4 FINAL) - MEA Market	MEA
---	-----

### Engine

Type	Water-cooled, 4-cycle diesel, 4-cylinder in line, High pressure common rail system (electric control), Turbocharger with air cooled intercooler, SCR system	
Model	ISUZU AQ-4HK1X	
Rated flywheel horse power		
	<b>SAE J1349, ISO 9249</b>	<b>132.1 kW (180 Hp) at 2000 RPM</b>
	<b>ISO 14396</b>	<b>140 kW (190 Hp) at 2000 RPM</b>
Piston displacement	<b>5193 cm<sup>3</sup> (317 in<sup>3</sup>)</b>	
Maximum torque		
	<b>SAE J1349, ISO 9249</b>	<b>621 N·m (458 lb ft) at 1800 RPM</b>
	<b>ISO 14396</b>	<b>642 N·m (474 lb ft) at 1800 RPM</b>
Bore and stroke	<b>115 - 125 mm (4.53 - 4.92 in)</b>	
Voltage	<b>24 V</b>	
Alternator	<b>50 A</b>	
Starter	<b>24 V 5.0 kW</b>	

### Hydraulic system

Main pumps	2 variable displacement axial piston pumps with regulating system	
	Max. oil flow	<b>2 × 234 L (61.8 US gal) at 2000 RPM</b>
	Working circuit pressure	Boom/Arm/Bucket
		<b>34.3 MPa (4975 psi)</b>
		Arm In
		<b>37.3 MPa (5410 psi) with auto power up</b>
		Bucket/Boom Down
	Swing circuit	<b>21.1 MPa (3061 psi)</b>
	Travel circuit	<b>29.4 MPa (4264 psi)</b>
		<b>27.0 MPa (3916 psi)</b>
		<b>34.3 MPa (4975 psi)</b>
Pilot pump	1 gear pump	
	Max. oil flow	<b>20 L (5.3 US gal)</b>
	Working circuit pressure	<b>3.9 MPa (566 psi)</b>
Control valves	With Boom/Arm holding valve	
	One 4-spool valve for Right track travel, Bucket, Boom and Arm acceleration	
	One 5-spool valve for Left track travel, Auxiliary, Swing, Boom acceleration and Arm	
Swing device		
	Motor	Fixed displacement axial piston motor
	Brake	Mechanical disc brake
	Final drive	Planetary gear reduction
	Turn table bearing	Ball bearing type with internal gear
	Maximum swing speed	<b>10.6 RPM</b>
	Swing torque	<b>69.800 N·m (51.482 lb ft)</b>
Cylinders	NO. of cylinders – bore X Rod diameter X Stroke	
	Boom	<b>2 x Ø 130 mm (5.118 in) - Ø 90 mm (3.543 in) - 1335 mm (52.559 in)</b>
	Arm	<b>1 x Ø 150 mm (5.906 in) - Ø 105 mm (4.134 in) - 1737 mm (68.386 in)</b>
	Bucket	<b>1 x Ø 95 mm (3.740 in) - Ø 65 mm (2.559 in) - 881 mm (34.685 in)</b>
Cooling system		
	Fan	<b>Ø 650 mm (25.6 in) with 7-blades</b>
	Radiator capacity	<b>105.9 kW</b>
		fin type
		Corrugated fin (wavy type)

## INTRODUCTION

	fin space	<b>1.75 mm (0.06890 in)</b>
Long life coolant		Coolant 55 % , Water 45 %
Oil cooler capacity		<b>54.1 kW</b>
	fin type	Corrugated fin (wavy type)
	fin space	<b>1.75 mm (0.06890 in)</b>
Intercooler capacity		<b>16.7 kW</b>
	fin type	Straight fin
	fin space	<b>1.75 mm (0.06890 in)</b>
Fuel cooler capacity		<b>1.3 kW</b>
	fin type	Corrugated fin (wavy type)
	fin space	<b>2.0 mm (0.0787 in)</b>
<b>Filters</b>		
Suction filter		105 µm
Return filter		6 µm
Pilot line filter		8 µm

### Hydraulic controls

Boom/Arm/Bucket/Swing	Pilot pressure control system (ISO control pattern)
Travel	Pilot pressure control system
Work mode select	SP - mode
	H - mode
	Auto - mode
Travel mode select	2-speed travel
Attachment cushion control	
Hydraulic lock (gate lock, left side tilt console)	

### Electrical system

<b>Engine control</b>		
	Dial type throttle control	
	One touch idle / Auto deceleration / Auto idle shutdown system	
	Emergency stop	
<b>Monitor system</b>		
	Message display (Caution, condition, etc.)	
	Work mode display (SP, H, Auto)	
	Machine condition (Power boost, etc.)	
	Alarm display and buzzer	
	Water temperature	
	Hydraulic oil temperature	
	Fuel level	
	Diagnosis system	
	Rear view camera image	
	Urea water level	
<b>Wire harness</b>		
	Waterproof type connector	
<b>Safety</b>		
	Double horn	
<b>Battery</b>	2 X 12 V 92 A·h/5HR	
<b>Lights</b>		
Working light	Upper	<b>24 V 70 W X 1</b>
	Boom	<b>24 V 70 W X 1</b>
	Cab	<b>24 V 70 W X 2</b>
Operator's cab room	<b>24 V 10 W X 1</b>	



## Operator environment

Operator's cab		
	Smooth and round shape design cab, fabricated by press work	
	Safety glass for all windows	
	Shock-less cab suspension by 4-point fluid mounting	
	Sliding front window with auto lock	
	Built-in type full-color LCD monitor display	
	Membrane switch on monitor display	
	Windshield wiper & washer	
	Floor mat	
	Polycarbonate roof hatch & Sun shade	
	Auto air-conditioner	
	Rain deflector	
	Sun visor	
	Roll-over protective structure (ROPS)	
	Top guard OPG level 1 (in CAB structure)	
Operator's seat		
	Low frequency air suspension with air springs and double acting hydraulic damper. (Achieves ISO7096 in category EM6)	
	With following features	
	Manual weight adjustment	Backrest angle adjustment
	Seat height adjustment	Adjustable pivoting armrests linked to consoles
	Adjustable headrest	Retractable seat belt
	Adjustable lumbar support	Control consoles adjust independently of seat
Others		
	Rear view mirror (Cab side & Right side)	
	Rear view Camera	

## Undercarriage

Travel motor	Variable displacement axial piston motor	
Brake	Mechanical disc brake	
Hydraulic service brake	Brake valve	
Final drive	Planetary gear reduction	
Travel speeds	High	<b>5.5 km/h (3.4 mph)</b> (Automatic travel speed shifting)
	Low	<b>3.5 km/h (2.2 mph)</b>
Drawbar pull	<b>200 kN (44962 lb)</b>	
Number of carrier rollers (each side)	2	
Number of track rollers (each side)	9	
Number of shoes (each side)	51	
Type of shoe	Triple grouser shoe	
Link pitch	<b>190 mm (7.480 in)</b>	
Width of shoe	<b>800 mm (31.496 in)</b> (S.T.D)	
Grade-ability	<b>70 % ( 35 ° )</b>	

**Mass**

Operating mass	<b>28900 kg (63714 lb)</b>
	with <b>8.00 m (26.25 ft) Arm, 0.37 m<sup>3</sup> Bucket, 800 mm (31.496 in) grouser shoe, operator, lubricant, coolant and full fuel tank</b>
Shipping mass	<b>28200 kg (62170 lb)</b>
	Operating mass - (operator mass [ <b>75 kg (165.35 lb)</b> ] + <b>90 %</b> of fuel mass + bucket mass [ <b>340 kg (749.572 lb)</b> ]
Counter weight mass	<b>7.350 kg (16.204 lb)</b>
Ground pressure	<b>0.043 MPa (6.237 psi)</b>
	with <b>8.00 m (26.25 ft) Arm, 0.37 m<sup>3</sup> Bucket, 800 mm (31.496 in) grouser shoe</b>

**Digging force (with 0.37 m<sup>3</sup> bucket) ( ISO 6015 )**

	<b>8.00 m (26.25 ft) Arm</b>
Arm digging force	<b>40 kN (8992 lb)</b>
Bucket digging force	<b>77 kN (17310 lb)</b>

**Dimensions**

	<b>8.00 m (26.25 ft) Arm</b>
Overall length (without attachment)	<b>5270 mm (207.480 in)</b>
Overall length (with attachment)	<b>14380 mm (566.142 in)</b>
Overall height (to top of boom)	<b>3130 mm (123.228 in)</b>
Overall height (to top of Cab)	<b>3020 mm (118.898 in)</b>
Overall height (to top of guardrail)	<b>3340 mm (131.496 in)</b>
Upper structure overall width	<b>2770 mm (109.055 in)</b>
Swing (rear end) radius	<b>2950 mm (116.142 in)</b>
Clearance height under upper structure	<b>1100 mm (43.307 in)</b>
Minimum ground clearance	<b>440 mm (17.323 in)</b>
Wheel base (Center to center of wheels)	<b>3840 mm (151.181 in)</b>
Crawler overall length	<b>4650 mm (183.071 in)</b>
Track gauge	<b>2590 mm (101.969 in)</b>
Undercarriage overall width [with <b>800 mm (31.496 in) shoes</b> ]	<b>3390 mm (133.465 in)</b>
Crawler tracks height	<b>940 mm (37.008 in)</b>

**Working ranges**

	<b>8.00 m (26.25 ft) Arm</b>
Boom length	<b>10300 mm (405.512 in)</b>
Bucket radius	<b>1200 mm (47.244 in)</b>
Bucket wrist action	<b>178 °</b>
Maximum reach at GRP	<b>18220 mm (717.323 in)</b>
Maximum reach	<b>18320 mm (721.260 in)</b>
Max. digging depth	<b>14560 mm (573.228 in)</b>
Max. digging height	<b>13950 mm (549.213 in)</b>
Max. dumping height	<b>11780 mm (463.780 in)</b>

## General specification - Main equipment

### Lower component

#### Travel unit

Manufacturer	KYB Corporation
Motor type	Variable displacement piston motor
	Automatic 2-speed switchover with parking brake
Absorption amount	<b>181.3 - 112.6 cm<sup>3</sup>/rev (11.1 - 6.9 in<sup>3</sup>/rev)</b>
Operating pressure	<b>34.3 MPa (4975 psi)</b>
Operating flow	<b>234 l/min (234.000 US gpm)</b>
Brake torque	<b>32.7 N·m (24.12 lb ft) or more (reduction gear included)</b>
Relief valve set pressure	<b>35.3 MPa (5120 psi)</b>
Automatic 2-speed switch over pressure	<b>25.8 MPa (3742.290 psi)</b>
Reduction gear	
Reduction gear type	Planetary gear 2-stage reduction gear
Reduction ratio	43.246
Dry weight	<b>271 kg (597.453 lb)</b>

#### Take-up roller

Weight	<b>99.3 kg (218.92 lb)</b>
--------	----------------------------

#### Upper roller

Weight	<b>17.8 kg (39.24 lb)</b>
--------	---------------------------

#### Lower roller

Weight	<b>37.7 kg (83.11 lb)</b>
--------	---------------------------

#### Recoil spring

Item	Weight	Quantity
Yoke	<b>25.7 kg (56.6588 lb)</b>	1
Sems B <b>M16 x 50</b>	<b>0.5 kg (1.1023 lb)</b>	4
Threaded rod	<b>28.5 kg (62.8317 lb)</b>	1
Groove height N M48	<b>1.3 kg (2.8660 lb)</b>	1
SP pin 8 x 80	<b>0.1 kg (0.2205 lb)</b>	1
Recoil spring	<b>69.9 kg (154.1031 lb)</b>	1
Grease cylinder assembly	<b>32.8 kg (72.3116 lb)</b>	1
Sems B M16 x 60	<b>0.3 kg (0.6614 lb)</b>	2
Assembly (total)	<b>160.9 kg (354.7238 lb)</b>	
Mounting length of spring	<b>576 mm (22.677 in)</b>	

#### Shoes (Standard version)

	Weight or quantity
600 grouser (shoe)	<b>1476 kg (3254.023 lb)</b>
Link	1 pair
Shoe	51
Bolt	204
Nut	204
700 grouser (shoe)	<b>1618 kg (3567.079 lb)</b>
Link	1 pair
Shoe	51
Bolt	204
Nut	204
800 grouser (shoe)	<b>1766 kg (3893.364 lb)</b>
Link	1 pair

INTRODUCTION

	Weight or quantity
Shoe	51
Bolt	204
Nut	204
900 grouser (shoe)	<b>1909 kg (4208.625 lb)</b>
Link	1 pair
Shoe	51
Bolt	204
Nut	204

**Shoes (Long Reach version)**

	Weight or quantity
700 grouser	<b>1618 kg (3567.079 lb)</b>
Link	1 pair
Shoe	51
Bolt	204
Nut	204
800 grouser	<b>1766 kg (3893 lb)</b>
Link	1 pair
Shoe	51
Bolt	204
Nut	204

**Upper component**

**Swing unit (Standard version)**

Swing motor assembly		
Swing motor		
Manufacturer	Kawasaki Precision Machinery Ltd.	
Motor type	Fixed displacement piston motor	
	With parking brake	
Absorption amount	<b>148.5 cm<sup>3</sup>/rev (9.06 in<sup>3</sup>/rev)</b>	
Operating pressure	<b>28.9 MPa (4191.945 psi)</b>	
Operating flow	<b>214 L/min (56.533 US gpm)</b>	
Mechanical brake torque	<b>846.0 N·m (623.978 lb ft) or more</b>	
Brake off pressure	<b>2.9 MPa (420.645 psi) or less</b>	
Relief valve set pressure	<b>28.9 MPa (4191.945 psi)</b>	
Swing reduction gear		
Reduction gear type	Planetary gear 2-stage reduction gear	
Reduction ratio	21.75	
Dry weight	<b>293 kg (645.954 lb)</b>	
Turntable bearing		
Number of teeth	92	
Weight	<b>373 kg (822.324 lb)</b>	
Counterweight		
Weight	<b>5200 kg (11464.038 lb)</b>	

**Swing unit (Long Reach version)**

Swing motor assembly		
Swing motor		
Manufacturer	Kawasaki Heavy Industries, Ltd.	
Motor type	Fixed displacement piston motor	
	With parking brake	
Absorption amount	<b>148.5 cm<sup>3</sup>/rev (9.06 in<sup>3</sup>/rev)</b>	
Operating pressure	<b>27.0 MPa (3916.35 psi)</b>	
Operating flow	<b>214 L/min (56.533 US gpm)</b>	
Mechanical brake torque	<b>846.0 N·m (623.978 lb ft) or more</b>	
Brake off pressure	<b>2.9 MPa (420.645 psi) or less</b>	
Relief valve set pressure 2	<b>7.0 MPa (1015.35 psi)</b>	
Swing reduction gear		
Reduction gear type	Planetary gear 2-stage reduction gear	
Reduction ratio	21.75	
Dry weight	<b>293 kg (645.954 lb)</b>	
Turntable bearing		
Number of teeth	92	
Weight	<b>373 kg (822.324 lb)</b>	
Counterweight		
Weight	<b>7350 kg (16203.976 lb)</b>	

## Engine-related

### Engine

Engine model name	Isuzu 4HK1X diesel engine
Engine type	4-cycle, water-cooled, overhead camshaft, vertical in-line, direct injection type (electronics control type)
Number of cylinders - diameter - stroke	4- $\phi$ 115 mm (4.53 in) - 125 mm (4.92 in)
Total displacement	5.193 l (5.1930 US gal)
Compression ratio	16.5
Rated output	132.1 kW (179.61 Hp) / 2000 RPM
Maximum torque	621 N·m (458.03 lb ft) / 1800 RPM
Engine dry weight	About 520 kg (1146.404 lb)
Cooling fan	650 mm (25.591 in) - suction type - 7 blades resin
	With bell mouth-type fan guide
Pulley ratio	0.85 (reduction)
Charging generator	24 V 50 A AC type
Starter motor	24 V 5 kW (6.8 Hp) reduction type
Coolant capacity	14.5 l (3.830 US gal)
Oil pan capacity	Max: 20 L (5.283 US gal) Min: 13 L (3.434 US gal) KSH10440
Direction of rotation	Right (viewed from fan side)

### Air cleaner (double element)

Manufacturer	Nippon Donaldson, Ltd.	
Element (outer)	Filtering area size	5.23 m <sup>2</sup> (56.30 ft <sup>2</sup> )
Element (inner)	Filtering area size	0.11 m <sup>2</sup> (1.18 ft <sup>2</sup> )
Weight	7.5 kg (16.535 lb)	

### Radiator

Manufacturer	T.Rad. Co.,Ltd.	
Oil cooler	Weight	32.3 kg (71.209 lb)
	Oil volume	13.6 L (3.593 US gal)
Radiator	Weight	17.0 kg (37.479 lb)
	Coolant capacity	10.0 L (2.642 US gal)
Air cooler	Weight	7.3 kg (16.094 lb)
	Capacity	-
Fuel cooler	Weight	1.1 kg (2.425 lb) x 2
	Capacity	0.44 L (0.1162 US gal) x 2
Total weight	115 kg (253.532 lb)	

### SCR

Manufacturer	Tokyo Radiator MFG. Co.,Ltd.	
Urea capacity	138.1 L (36.482 US gal)	
Weight	13.6 kg (29.98 lb)	

---

## Hydraulic device

### Hydraulic pump

Manufacturer		Kawasaki Heavy Industries, Ltd.
Main pump		
Pump type		Double variable displacement piston pump
Displacement		<b>118.5 cm<sup>3</sup>/rev (7.231 in<sup>3</sup>/rev) x 2</b>
Operating pressure	Rated	<b>34.3 MPa (4975 psi)</b>
	Maximum	<b>37.3 MPa (5410.4 psi)</b>
Input revolution speed		<b>2000 RPM</b>
Maximum discharge flow		<b>234 L/min (61.82 US gpm) x 2 (at Pd = 2000 RPM)</b>
Pilot pump		
Pump type		Gear pump
Displacement		<b>10 cm<sup>3</sup>/rev (0.61 in<sup>3</sup>/rev)</b>
Operating pressure		<b>3.9 MPa (565.7 psi)</b>
Maximum discharge flow		<b>20 L/min (5.28 US gpm) (at 2000 RPM)</b>
Control method		Hydraulic simultaneous constant output control (as fail-safe)
		Electric negative control by external command milli-amp (on front and rear sides)
Dry weight		<b>152.7 kg (336.646 lb)</b>

**Control-related**

**Control valve (Standard version)**

Manufacturer	KYB Corporation	
Maximum flow	<b>237 L/min (62.609 US gpm) (at 2000 RPM)</b>	
Overload set pressure	<b>29.4 MPa (4264.470 psi)</b> , boom down	
	<b>39.2 MPa (5685.960 psi)</b> boom up, arm, bucket	
Main relief set pressure	<b>34.3 MPa (4975 psi)</b>	
	(Upon pressure boost)	<b>37.3 MPa (5410 psi)</b>
Foot relief set pressure	<b>2.55 MPa (370 psi)</b>	
Function	Pressure boost circuit	
	Straight Travel Circuit	
	Boom-up and arm-out/in 2 pumps internal flow	
	Boom-down and arm-in load holding circuit	
	Boom-down and bucket-close regenerative circuit	
	Arm-in forced regenerative circuit	
	Arm 1 and Arm 2 parallel variable spool	
	Neutral cut spool	
	2 pumps flow	
Weight	<b>250 kg (551.156 lb)</b>	

**Control valve (Long Reach version)**

Manufacturer	KYB Corporation	
Maximum flow	<b>237 L/min (62.609 US gpm) (at 2000 RPM)</b>	
Overload set pressure	<b>21.1 MPa (3060.56 psi)</b> , boom down	
	<b>29.4 MPa (4264.470 psi)</b> bucket open (A7), bucket close (B7), boom down (B8)	
	<b>32.9 MPa (4772.145 psi)</b> , arm up (A5), boom up (A8)	
Main relief set pressure	<b>34.3 MPa (4975 psi)</b>	
	(Upon pressure boost)	<b>37.3 MPa (5410 psi)</b>
Foot relief set pressure	<b>2.55 MPa (370 psi)</b>	
Function	Pressure boost circuit	
	Straight Travel Circuit	
	Boom-up and arm-out/in 2 pumps internal flow	
	Boom-down and arm-in load holding circuit	
	Boom-down and bucket-close regenerative circuit	
	Arm-in forced regenerative circuit	
	Arm 1 and Arm 2 parallel variable spool	
	Neutral cut spool	
	2 pumps flow	
Weight	<b>250 kg (551.156 lb)</b>	

**Solenoid valve (5 stack)**

Manufacturer	Yuken Kogyo Co., Ltd.	
Valve specifications		
Maximum flow	SP: <b>30 L/min (7.925 US gpm)</b> , Others: <b>5 L/min (1.321 US gpm)</b>	
Rated pressure	<b>4.5 MPa (652 psi)</b>	
Port size	<b>G3/8</b>	Port P0, P1, D1, D2
	<b>G1/4</b>	Port C1, C3, C12
Solenoid specifications		
Operating voltage	<b>20 - 32 V DC</b>	
Power consumption	<b>17 W</b> or less	
Weight	<b>7 kg (15.432 lb)</b>	



## INTRODUCTION

### Remote control valve for Left/Right operations

Manufacturer		Kawasaki Precision Machinery Ltd.
Operating pressure		<b>3.92 MPa (569 psi)</b>
Secondary pressure		<b>0.64 - 2.45 MPa (92.8320 - 355 psi)</b> , primary pressure short type
Operating angle	port 1,3	<b>19 °</b>
	port 2,4	<b>25 °</b>
Weight		<b>1.9 kg (4.1888 lb)</b>

### Remote control valve for travel operation

Manufacturer		Kawasaki Precision Machinery Ltd.
Operating pressure		<b>3.92 MPa (569 psi)</b>
Secondary pressure		<b>0.64 - 2.45 MPa (92.8320 - 355 psi)</b> , primary pressure short type
Operating angle		<b>12.4 °</b>
Weight		<b>4.1 kg (9.039 lb)</b>

### Operation remote control valve control diagram

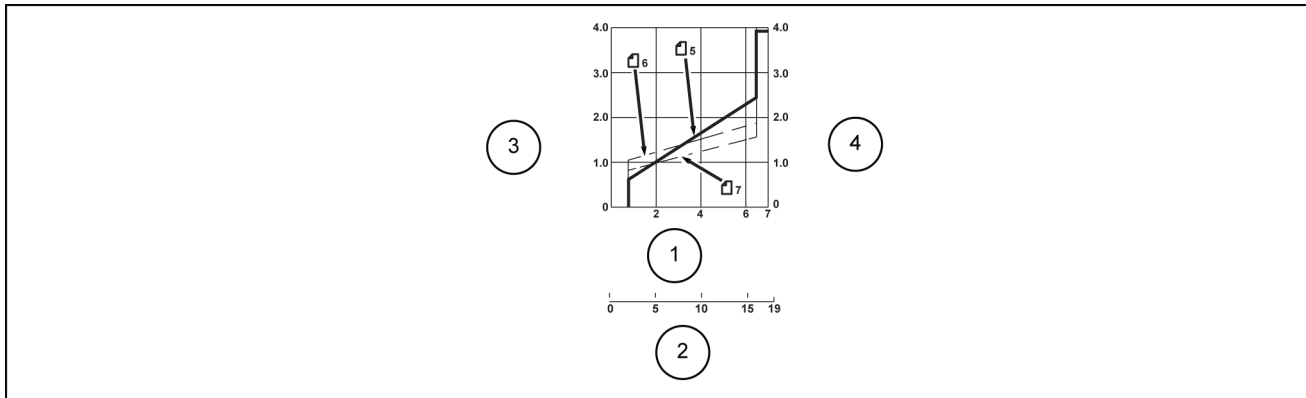

1	Push rod stroke [mm (in)]	5	Secondary pressure
2	Operating angle [deg.]	6	Independent operating torque (Port 1)
3	Secondary pressure [MPa (psi)]	7	Independent operating torque (Port 3)
4	Operating torque [Nm]		

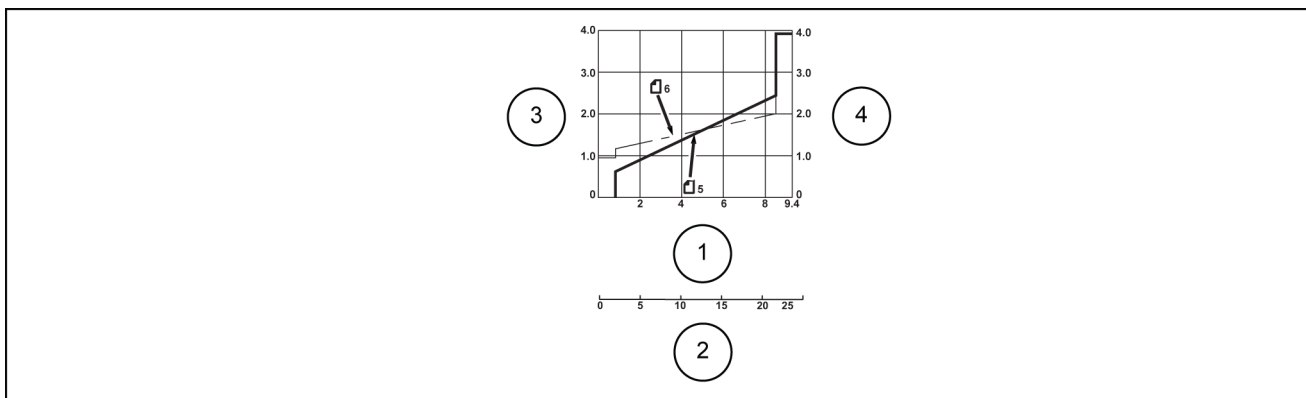

1	Push rod stroke [mm (in)]	4	Operating torque [Nm]
2	Operating angle [deg.]	5	Secondary pressure
3	Secondary pressure [MPa (psi)]	6	Independent operating torque

**Travel remote control valve control diagram**

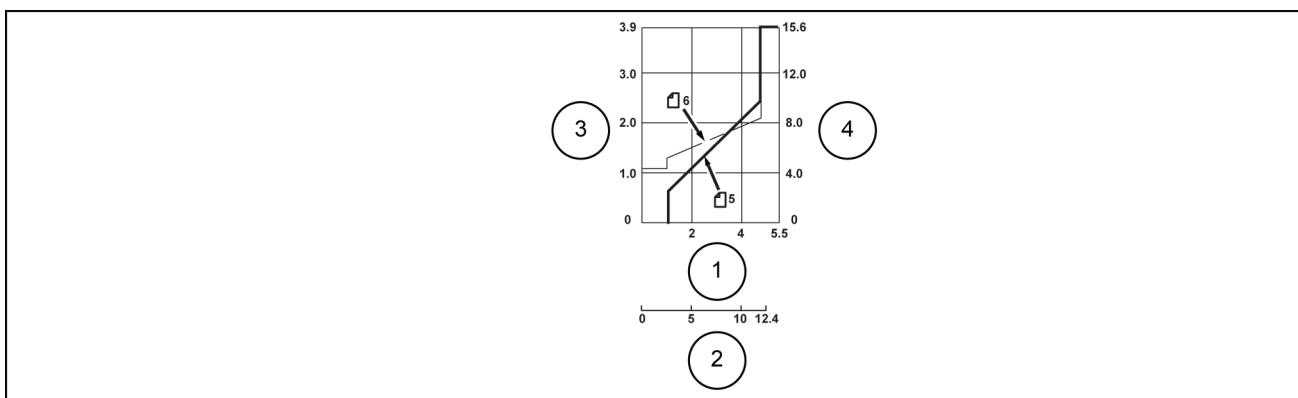

SMIL14CEX2904EB 3

1	Push rod stroke [mm (in)]	4	Operating torque [Nm]
2	Operating angle [deg.]	5	Secondary pressure
3	Secondary pressure [MPa (psi)]	6	Independent operating torque

**Cushion valve (heat circuit, with shuttle valve)**

Manufacturer	Yanagisawa Seiki MFG. Co., Ltd.
Port size	<b>G3/8</b> ( A - P port)
	<b>G1/4</b> ( Q - V port)
Weight	<b>12.5 kg (27.5578 lb)</b>

**Selector valve (option)**

2WAY	
Manufacturer	Nishina Industrial Co., Ltd.
Rated flow rate	<b>25 l/min (6.604 US gpm)</b>
Operating method	ISO
Port size	<b>G3/8</b>
Weight	<b>4 kg (8.8185 lb)</b>

**Center joint**

Operating pressure	High-pressure passage (ABCD)	<b>34.3 MPa (4975 psi)</b>
	Drain port (E)	<b>0.5 MPa (72.52 psi)</b>
	Pilot port (P)	<b>3.9 MPa (566 psi)</b>
Flow amount	High-pressure passage (ABCD)	<b>234 L/min (61.816 US gpm)</b>
	Drain port (E)	<b>10 L/min (2.642 US gpm)</b>
	Pilot port (F)	<b>21 L/min (5.548 US gpm)</b>
Port A	Forward right	G3/4
Port B	Forward left	G3/4
Port C	Backward right	G3/4
Port D	Backward left	G3/4
Port E	Drain port	<b>G1/2</b>
Port F	Pilot port	<b>G1/4</b>
Weight		<b>29 kg (63.9341 lb)</b>

**Cylinder (Standard version)**

<b>Boom cylinder</b>	
Cylinder bore	Æ 130 mm (5.118 in)
Rod diameter	Æ 90 mm (3.543 in)
Maximum retracted length	1855 mm (73.031 in)
Stroke	1335 mm (52.559 in)
Weight	201 kg (443.129 lb)

<b>Arm cylinder</b>	
Cylinder bore	Æ 145 mm (5.709 in)
Rod diameter	Æ 105 mm (4.134 in)
Maximum retracted length	2240 mm (88.189 in)
Stroke	1660 mm (65.354 in)
Weight	324 kg (714.298 lb)

<b>Bucket cylinder</b>	
Cylinder bore	Æ 130 mm (5.118 in)
Rod diameter	Æ 90 mm (3.543 in)
Maximum retracted length	1635 mm (64.370 in)
Stroke	1070 mm (42.126 in)
Weight	187 kg (412.264 lb)

**Cylinder (Long Reach version)**

<b>Boom cylinder</b>	
Cylinder bore	Æ 130 mm (5.118 in)
Rod diameter	Æ 90 mm (3.543 in)
Maximum retracted length	1855 mm (73.031 in)
Stroke	1335 mm (52.559 in)
Weight	201 kg (443.129 lb)

<b>Arm cylinder</b>	
Cylinder bore	Æ 150 mm (5.906 in)
Rod diameter	Æ 105 mm (4.134 in)
Maximum retracted length	2425 mm (95.472 in)
Stroke	1737 mm (68.386 in)
Weight	355 kg (782.641 lb)

<b>Bucket cylinder</b>	
Cylinder bore	Æ 95 mm (3.740 in)
Rod diameter	Æ 65 mm (2.559 in)
Maximum retracted length	1373 mm (54.055 in)
Stroke	881 mm (34.685 in)
Weight	91 kg (200.621 lb)

# Weight

CX250D Crawler excavators LC version (TIER4 FINAL) - MEA Market

MEA

## Divided weight

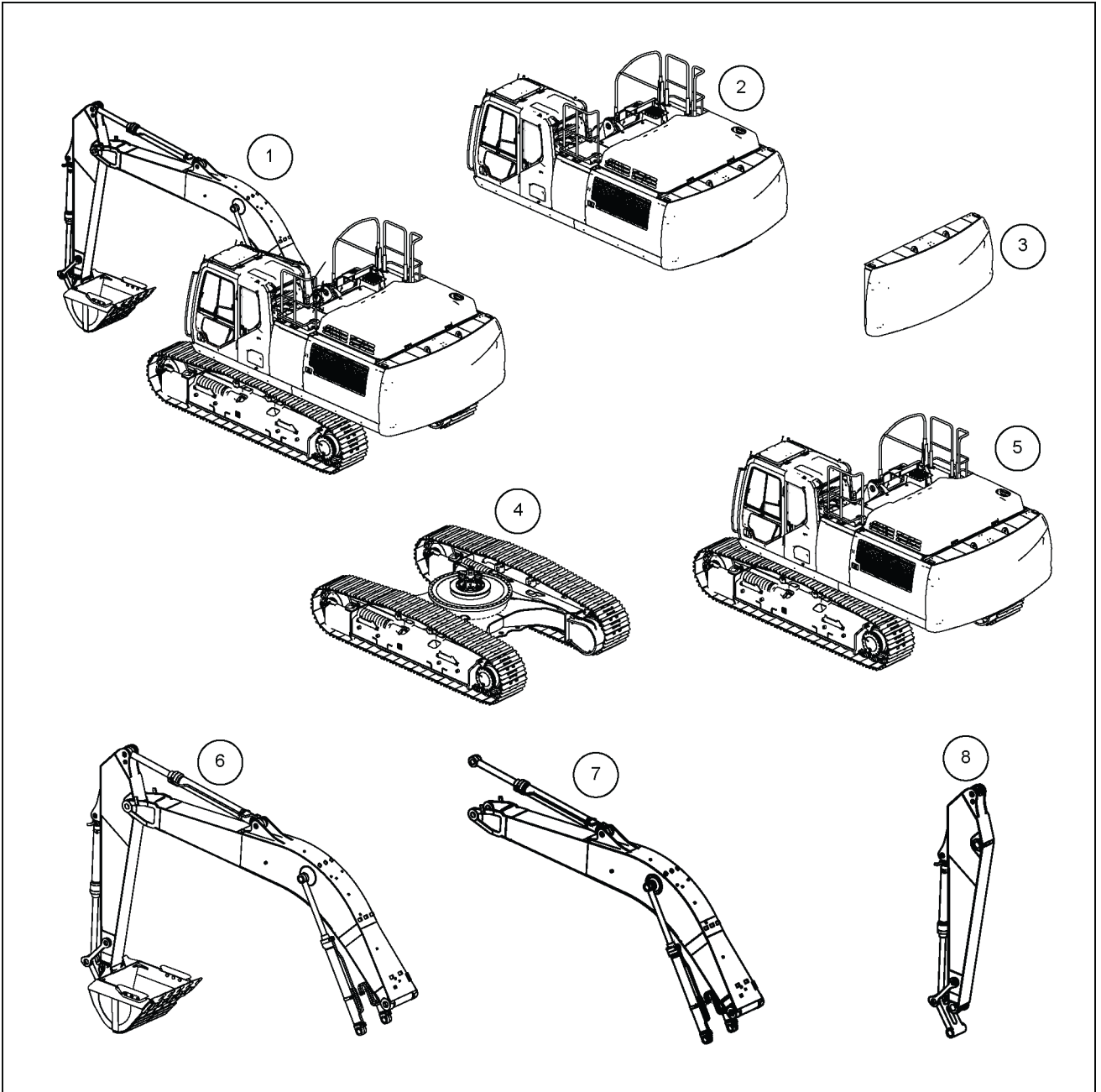

SML14CEX2905GB 1

Code	Part name	Weight
1	Operating weight	25380 kg (55953.322 lb)
2	Upper component (including CW and TTB)	11450 kg (25242.929 lb)
3	Counterweight	5220 kg (11508.130 lb)
4	Lower component (with grouser shoe)	8330 kg (18364.506 lb)
5	Main unit weight	20560 kg (45327.041 lb)
6	Attachments	4740 kg (10449.911 lb)
7	Boom (including cylinder)	2660 kg (5864.296 lb)
8	Arm (including cylinder and linkage)	1280 kg (2821.917 lb)

**NOTE:** The weights shown here are approximate values.

**Stand alone part weight**

	<b>Part name</b>		<b>Weight</b>
1	Travel unit		<b>271 kg (597.453 lb)</b>
2	Take-up roller		<b>99 kg (218.258 lb)</b>
3	Upper roller		<b>18 kg (39.683 lb)</b>
4	Lower roller		<b>38 kg (83.776 lb)</b>
5	Swing unit		<b>293 kg (645.954 lb)</b>
6	Turntable bearing		<b>373 kg (822.324 lb)</b>
7	Engine		<b>654 kg (1441.823 lb)</b>
8	Radiator		<b>115 kg (253.532 lb)</b>
9	Hydraulic pump		<b>153 kg (337.307 lb)</b>
10	Fuel tank		<b>175 kg (385.809 lb)</b>
11	Hydraulic oil tank		<b>185 kg (407.855 lb)</b>
12	Control valve		<b>250 kg (551.156 lb)</b>
13	Center joint		<b>30 kg (66.139 lb)</b>
14	Boom	Standard	<b>1624 kg (3580.307 lb)</b>

**Shoe weight (per side)**

	<b>Part name</b>		<b>Weight</b>
1	<b>600 mm (23.62 in)</b> grouser shoe		<b>1476 kg (3254.023 lb)</b>
2	<b>700 mm (27.56 in)</b> grouser shoe		<b>1618 kg (3567.079 lb)</b>
3	<b>800 mm (31.50 in)</b> grouser shoe		<b>1766 kg (3893.364 lb)</b>

**Arm weight**

	<b>Part name</b>	<b>Weight</b>
1	Standard arm (EM3 O1 QC)	<b>785.9 kg (1732.613 lb)</b>
2	Standard arm (EM3 O1)	<b>785.3 kg (1731.290 lb)</b>
3	Standard arm (EM3 HD O1)	<b>901.7 kg (1987.908 lb)</b>
4	Standard arm (EM3 HD O12)	<b>906.4 kg (1998.270 lb)</b>
5	Standard arm (EM3 O12 QC)	<b>790.6 kg (1742.975 lb)</b>
6	Standard arm (EM3 O12)	<b>790 kg (1741.652 lb)</b>
7	Standard arm (HD EM3 O1 QC)	<b>902.3 kg (1989.231 lb)</b>
8	Standard arm (HD EM3 O12 QC)	<b>907 kg (1999.593 lb)</b>
9	Short arm (EM3 HD O1 QC)	<b>754.6 kg (1663.608 lb)</b>
10	Short arm (EM3 HD O1)	<b>754 kg (1662.285 lb)</b>
11	Short arm (EM3 HD O12)	<b>756.9 kg (1668.679 lb)</b>
12	Short arm (HD EM3 O12 QC)	<b>758.7 kg (1672.647 lb)</b>
13	Long arm (EM3 O1 PL)	<b>994.6 kg (2192.718 lb)</b>
14	Long arm (EM3 O1 QC)	<b>892.2 kg (1966.964 lb)</b>
15	Long arm (EM3 O1)	<b>891.6 kg (1965.642 lb)</b>
16	Long arm (EM3 O12 PL)	<b>999.3 kg (2203.079 lb)</b>
17	Long arm (EM3 O12 QC)	<b>896.9 kg (1977.326 lb)</b>
18	Long arm (EM3 O12)	<b>896.3 kg (1976.003 lb)</b>
19	Long arm (EM3 PL O1 QC)	<b>995.2 kg (2194.040 lb)</b>
20	Long arm (EM3 PL O12 QC)	<b>999.9 kg (2204.402 lb)</b>

# Weight

CX250D Long Reach Crawler excavators LC Long Reach (TIER4 FINAL) - MEA  
 MEA Market

## Divided weight

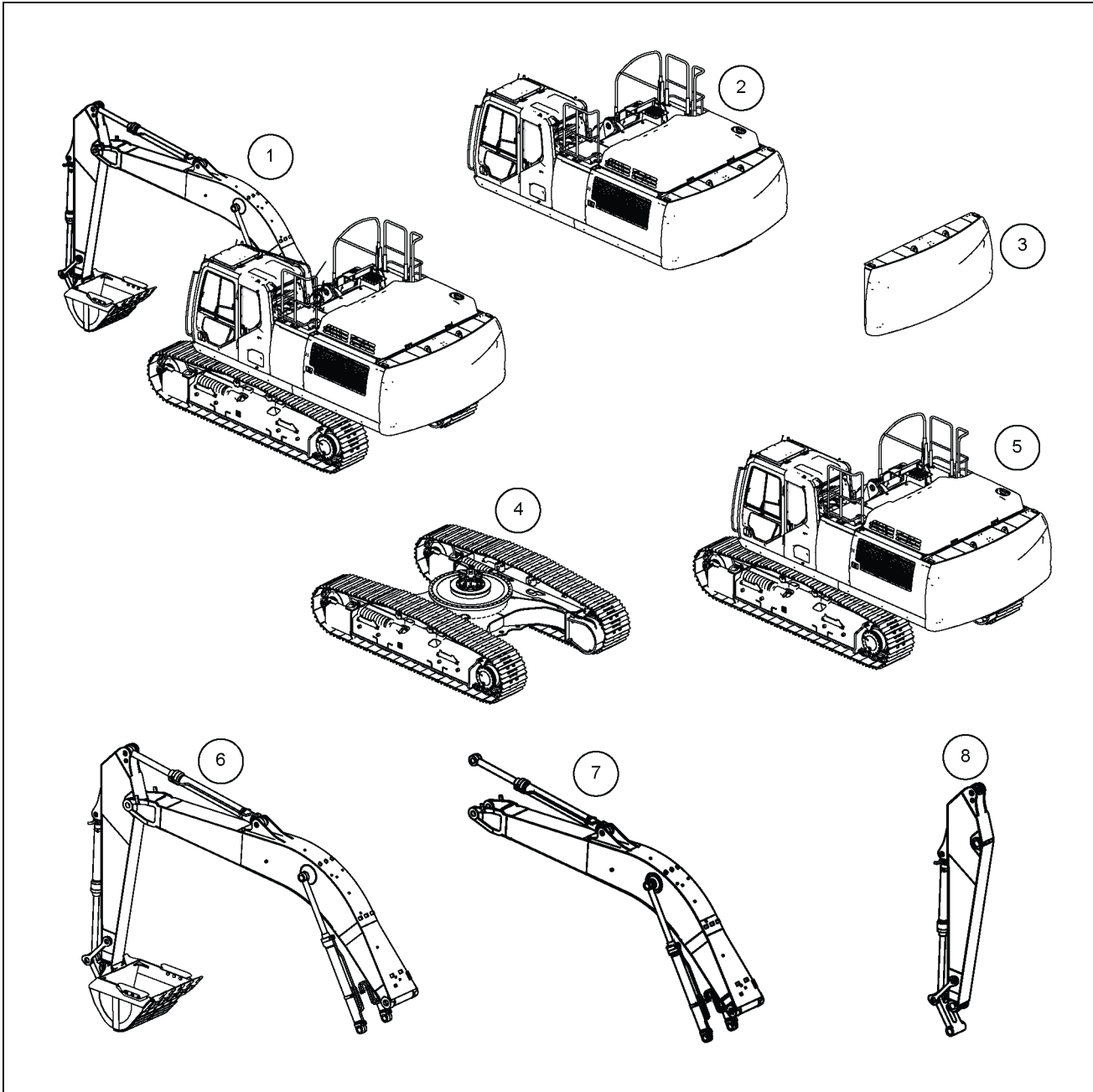

SMIL14CEX2905GB 1

Code	Part name	Weight
1	Operating weight	28600 kg (63052.207 lb)
2	Upper component (including CW and TTB)	13600 kg (29982.868 lb)
3	Counterweight	7400 kg (16314.207 lb)
4	Lower component (with grouser shoe)	8900 kg (19621.141 lb)
5	Main unit weight	23300 kg (51367.707 lb)
6	Attachment	5300 kg (11684.500 lb)
7	Boom (including cylinder)	3600 kg (7936.641 lb)
8	Arm (including cylinder and linkage)	1600 kg (3527.396 lb)

**NOTE:** The weights shown here are approximate values.

**Stand alone part weight**

	<b>Part name</b>	<b>Weight</b>
1	Travel unit	<b>271 kg (597.453 lb)</b>
2	Take-up roller	<b>99 kg (218.258 lb)</b>
3	Upper roller	<b>18 kg (39.683 lb)</b>
4	Lower roller	<b>38 kg (83.776 lb)</b>
5	Swing unit	<b>293 kg (645.954 lb)</b>
6	Turntable bearing	<b>373 kg (822.324 lb)</b>
7	Engine	<b>654 kg (1441.823 lb)</b>
8	Radiator	<b>115 kg (253.532 lb)</b>
9	Hydraulic pump	<b>153 kg (337.307 lb)</b>
10	Fuel tank	<b>175 kg (385.809 lb)</b>
11	Hydraulic oil tank	<b>185 kg (407.855 lb)</b>
12	Control valve	<b>250 kg (551.156 lb)</b>
13	Center joint	<b>30 kg (66.139 lb)</b>
14	Boom	<b>2511 kg (5535.807 lb)</b>

**Shoe weight (per side)**

	<b>Part name</b>	<b>Weight</b>
1	<b>700 mm (27.56 in)</b> grouser shoe	<b>1618 kg (3567.079 lb)</b>
2	<b>800 mm (31.50 in)</b> grouser shoe	<b>1766 kg (3893.364 lb)</b>

**Arm weight**

	<b>Part name</b>	<b>Weight</b>
1	Ultra long arm	<b>1336 kg (2945.376 lb)</b>



## Dimension

CX250D Crawler excavators LC version (TIER4 FINAL) - MEA Market

MEA

### Standard arm [ 3.00 m (9.84 ft)]

**NOTE:** The values used in this document are subject to change without notice due to a design change or other reasons.

The values indicated in the diagram include the shoe lug height (a) [ 26 mm (1.024 in) ].

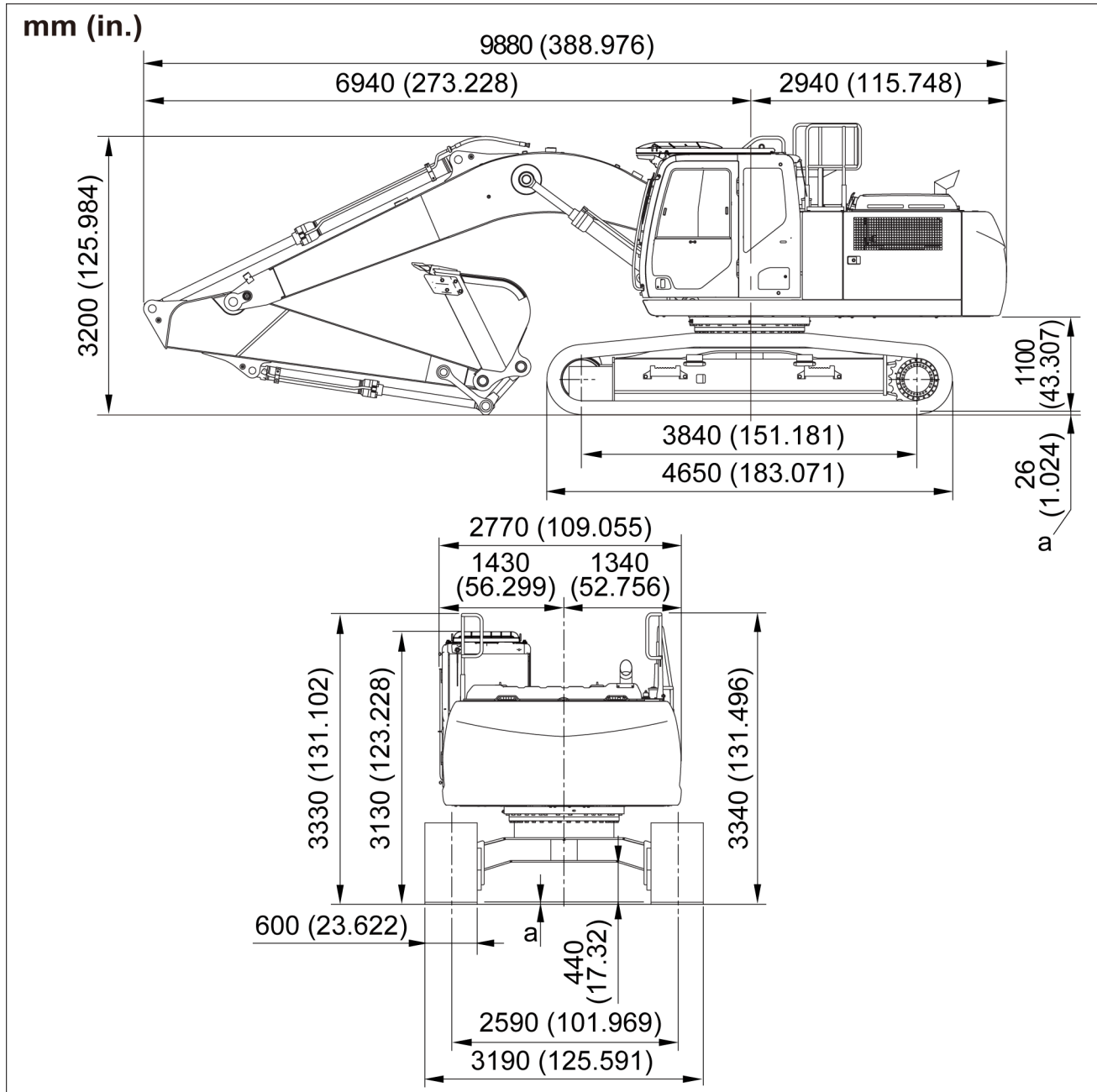

SMIL15CEX2916GB 1

**Short arm [ 2.50 m (8.20 ft)]**

**NOTE:** The values used in this document are subject to change without notice due to a design change or other reasons.

The values indicated in the diagram include the shoe lug height (a) [ 26 mm (1.024 in) ].

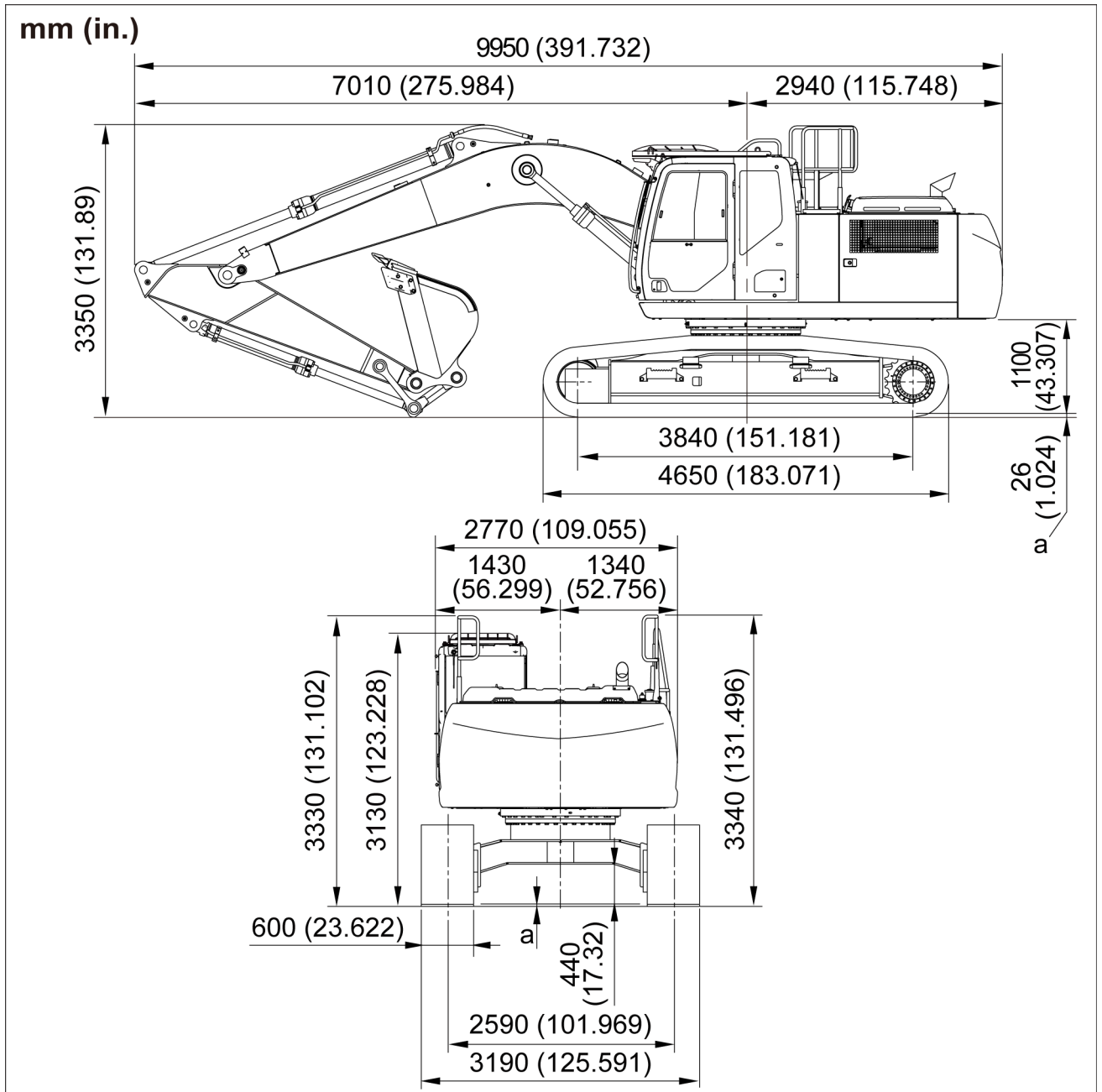

SML15CEX2917GB 2

**Long arm [ 3.52 m (11.55 ft)]**

**NOTE:** The values used in this document are subject to change without notice due to a design change or other reasons.

The values indicated in the diagram include the shoe lug height (a) [ 26 mm (1.024 in) ].

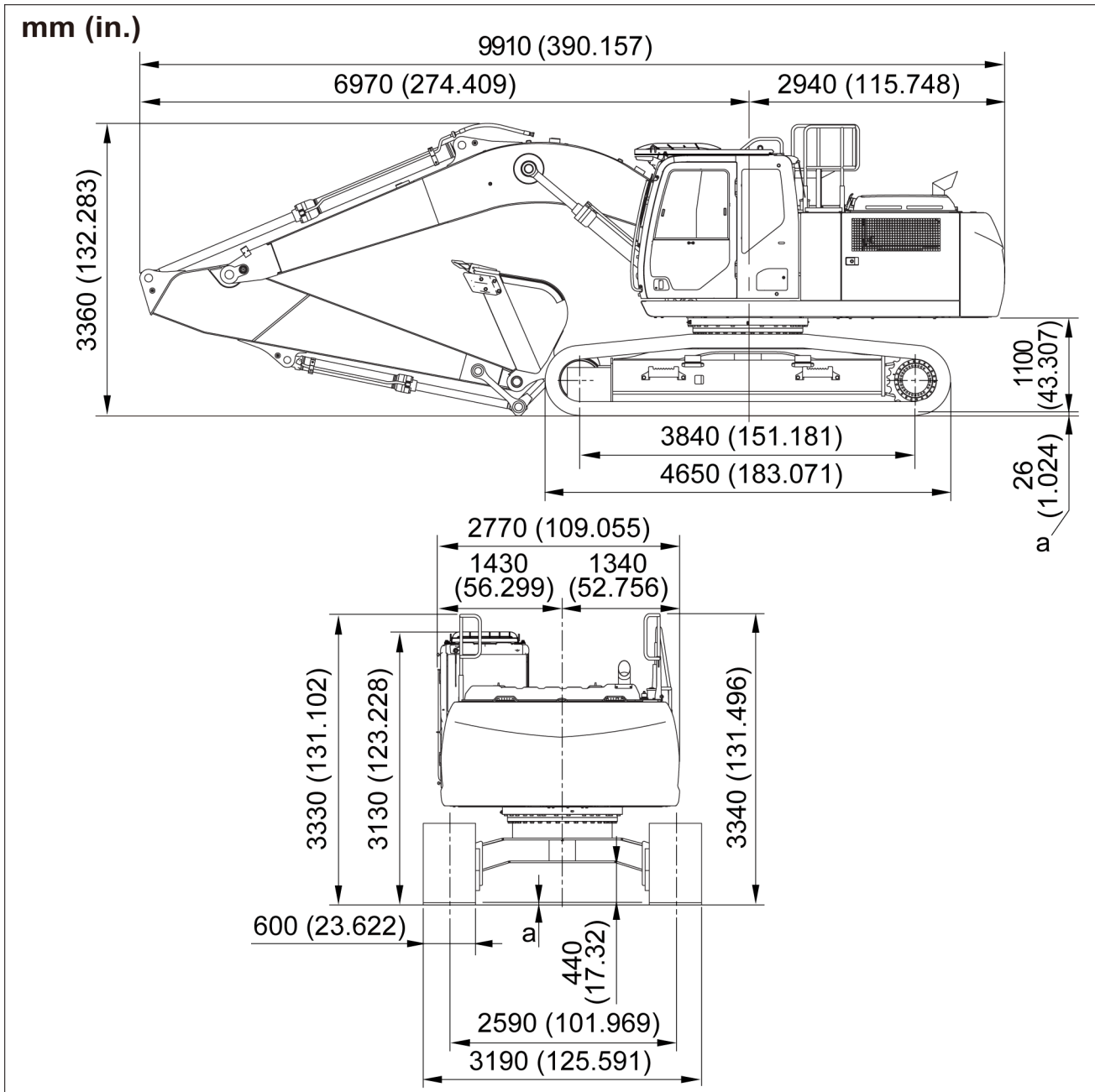

SMIL15CEX3308GB 3

## Dimension

CX250D Long Reach Crawler excavators LC Long Reach (TIER4 FINAL) - MEA Market	MEA
---	-----

### Ultra long arm [ 8.0 m (26.25 ft)]

**NOTE:** The values used in this document are subject to change without notice due to a design change or other reasons.

The values indicated in the diagram include the shoe lug height (a) [ 26 mm (1.024 in) ].

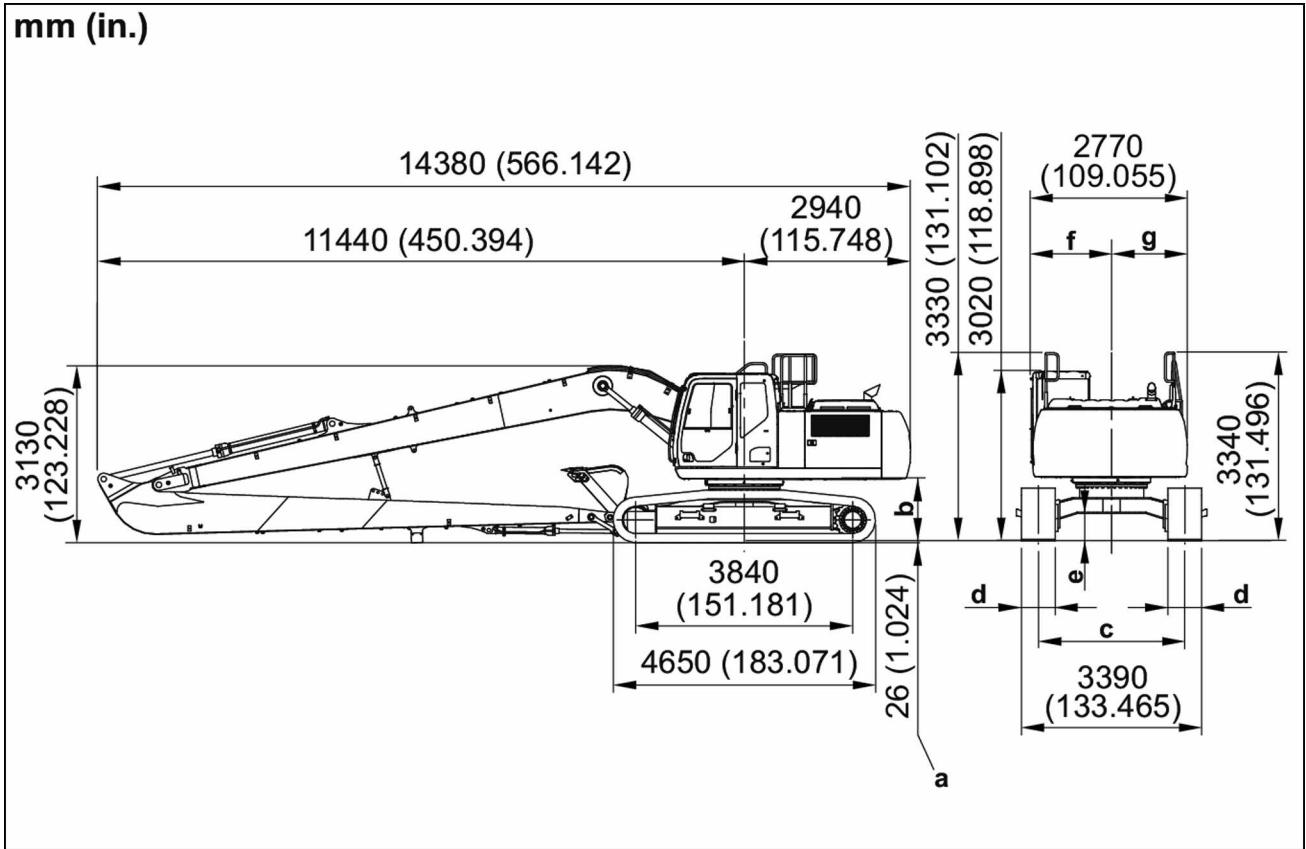

SMIL15CEX0331F 1

b	1100 mm (43.307 in)	d	880 mm (34.646 in)	f	1470 mm (57.874 in)
c	259 mm (10.197 in)	e	440 mm (17.323 in)	g	1340 mm (52.756 in)

## Conversion factors

### Unit conversion rate

Gravitational unit	- x → ← ÷ -	SI unit
kgf	9.807	N
lbf	4.448	N
kgf·cm	0.0981	N·m
lbf·ft	1.356	N·m
lbf·in	0.113	N·m
kgf/cm <sup>2</sup>	0.0981	MPa
atm	0.1013	MPa
lbf/in <sup>2</sup>	0.0069	MPa
mm Hg	133.3	Pa
in Hg	3386	Pa
kgf· m/s	0.00981	kW
lbf·ft/s	0.00136	kW
PS	0.7355	kW
HP	0.746	kW
kgf·m	9.807	J
kcal	4186	J
kgf·s/cm <sup>2</sup>	98067	Pa·s
cP	0.001	Pa·s
P	0.1	Pa·s
cSt	1 x 10 <sup>-6</sup>	m <sup>2</sup> /s
St	0.0001	m <sup>2</sup> /s

### Length

#### Millimeters to inches

mm	In.	mm	In.	mm	In.	mm	In.
1	0.0394	26	1.0236	51	2.0079	76	2.9921
2	0.0787	27	1.0630	52	2.0472	77	3.0315
3	0.1181	28	1.1024	53	2.0866	78	3.0709
4	0.1575	29	1.1417	54	2.1260	79	3.1102
5	0.1969	30	1.1811	55	2.1654	80	3.1496
6	0.2362	31	1.2205	56	2.2047	81	3.1890
7	0.2756	32	1.2598	57	2.2441	82	3.2283
8	0.3150	33	1.2992	58	2.2835	83	3.2677
9	0.3543	34	1.3386	59	2.3228	84	3.3071
10	0.3937	35	1.3780	60	2.3622	85	3.3465
11	0.4331	36	1.4173	61	2.4016	86	3.3858
12	0.4724	37	1.4567	62	2.4409	87	3.4252
13	0.5118	38	1.4961	63	2.4803	88	3.4646
14	0.5512	39	1.5354	64	2.5197	89	3.5039
15	0.5906	40	1.5748	65	2.5591	90	3.5433
16	0.6299	41	1.6142	66	2.5984	91	3.5827
17	0.6693	42	1.6535	67	2.6378	92	3.6220
18	0.7087	43	1.6929	68	2.6772	93	3.6614
19	0.7480	44	1.7323	69	2.7165	94	3.7008
20	0.7874	45	1.7717	70	2.7559	95	3.7402
21	0.8268	46	1.8110	71	2.7953	96	3.7795
22	0.8661	47	1.8504	72	2.8346	97	3.8189
23	0.9055	48	1.8898	73	2.8740	98	3.8583
24	0.9449	49	1.9291	74	2.9134	99	3.8976
25	0.9843	50	1.9685	75	2.9528	100	3.9370

INTRODUCTION

**Inches to millimeters**

in.	mm	in.	mm	in.	mm	in.	mm
1/64	0.3969	17/64	6.7469	33/64	13.0969	49/64	19.4469
1/32	0.7938	9/32	7.1438	17/32	13.4938	25/32	19.8438
3/64	1.1906	19/64	7.5406	35/64	13.8906	51/64	20.2406
1/16	1.5875	5/16	7.9375	9/16	14.2875	13/16	20.6375
5/64	1.9844	21/64	8.3344	37/64	14.6844	53/64	21.0344
3/32	2.3813	11/32	8.7313	19/32	15.0813	27/32	21.4313
7/64	2.7781	23/64	9.1281	39/64	15.4781	55/64	21.8281
1/8	3.1750	3/8	9.5250	5/8	15.8750	7/8	22.2250
9/64	3.5719	25/64	9.9218	41/64	16.2719	57/64	22.6219
5/32	3.9688	13/32	10.3188	21/32	16.6688	29/32	23.0188
11/64	4.3656	27/64	10.7156	43/64	17.0656	59/64	23.4156
3/16	4.7625	7/16	11.1125	11/16	17.4625	15/16	23.8125
13/64	5.1594	29/64	11.5094	45/64	17.8594	61/64	24.2094
7/32	5.5563	15/32	11.9063	23/32	18.2563	31/32	24.6063
15/64	5.9531	31/64	12.3031	47/64	18.6531	63/64	25.0031
1/4	6.3500	1/2	12.7000	3/4	19.0500	1	25.4000

**Feet to meters**

ft.	0	1	2	3	4	5	6	7	8	9	ft.
	m	m	m	m	m	m	m	m	m	m	
----		0.305	0.610	0.914	1.219	1.524	1.829	2.134	2.438	2.743	----
10	3.048	3.353	3.658	3.962	4.267	4.572	4.877	5.182	5.486	5.791	10
20	6.096	6.401	6.706	7.010	7.315	7.620	7.925	8.230	8.534	8.839	20
30	9.144	9.449	9.754	10.058	10.363	10.668	10.973	11.278	11.582	11.887	30
40	12.192	12.497	12.802	13.106	13.411	13.716	14.021	14.326	14.630	14.935	40
50	15.24	15.545	15.850	16.154	16.459	16.764	17.069	17.374	17.678	17.983	50
60	18.288	18.593	18.898	19.202	19.507	19.812	20.117	20.422	20.726	21.031	60
70	21.336	21.641	21.946	22.250	22.555	22.860	23.165	23.470	23.774	24.079	70
80	24.384	24.689	24.994	25.298	25.603	25.908	26.213	26.518	26.822	27.127	80
90	27.432	27.737	28.042	28.346	28.651	28.956	29.261	29.566	29.870	30.175	90
100	30.480	30.785	31.090	31.394	31.699	32.004	32.309	32.614	32.918	33.223	100

**Meters to feet**

m	0	1	2	3	4	5	6	7	8	9	m
	ft.	ft.	ft.	ft.	ft.	ft.	ft.	ft.	ft.	ft.	
----		3.2808	6.5617	9.8425	13.1234	16.4042	19.685	22.9659	26.2467	29.5276	----
10	32.8084	36.0892	39.3701	42.6509	45.9318	49.2126	52.4934	55.7743	59.0551	62.3360	10
20	65.6168	68.8976	72.1785	75.4593	78.7402	82.0210	85.3018	88.5827	91.8635	95.1444	20
30	98.4252	101.706	104.986	108.267	111.5486	114.829	118.1102	121.391	124.671	127.952	30
40	131.233	134.514	137.795	141.076	144.357	147.637	150.918	154.199	157.480	160.761	40
50	164.042	167.322	170.603	173.884	177.165	180.446	183.727	187.007	190.288	193.569	50
60	196.850	200.131	203.412	206.692	209.973	213.254	216.535	219.816	223.097	226.378	60
70	229.658	232.939	236.220	239.501	242.782	246.063	249.343	252.624	255.905	259.186	70
80	262.467	265.748	269.028	272.309	275.590	278.871	282.152	285.433	288.713	291.994	80
90	295.275	298.556	301.837	305.118	308.399	311.679	314.960	318.241	321.522	324.803	90
100	328.084	331.364	334.645	337.926	341.207	344.488	347.769	351.049	354.330	357.611	100

INTRODUCTION

**Miles to kilometers**

miles	0	1	2	3	4	5	6	7	8	9	miles
	km	km	km	km	km	km	km	km	km	km	
----		1.609	3.219	4.828	6.437	8.047	9.656	11.265	12.875	14.484	----
10	16.093	17.703	19.312	20.921	22.531	24.140	25.750	27.359	28.968	30.578	10
20	32.187	33.796	35.406	37.015	38.624	40.234	41.843	43.452	45.062	46.671	20
30	48.280	49.890	51.499	53.108	54.718	56.327	57.936	59.546	61.155	62.764	30
40	64.374	65.983	67.592	69.202	70.811	72.420	74.030	75.639	77.249	78.858	40
50	80.467	82.077	83.686	85.295	86.905	88.514	90.123	91.733	93.342	94.951	50
60	96.561	98.170	99.779	101.39	102.998	104.607	106.217	107.826	109.435	111.045	60
70	112.654	114.263	115.873	117.482	119.091	120.701	122.310	123.919	125.529	127.138	70
80	128.748	130.357	131.966	133.576	135.185	136.794	138.404	140.013	141.622	143.232	80
90	144.841	146.450	148.060	149.669	151.278	152.888	154.497	156.106	157.716	159.325	90
100	160.934	162.544	164.153	165.762	167.372	168.981	170.590	172.200	173.809	175.418	100

**Kilometers to miles**

km	0	1	2	3	4	5	6	7	8	9	km
	miles	miles	miles	miles	miles	miles	miles	miles	miles	miles	
----		0.621	1.243	1.864	2.485	3.107	3.728	4.350	4.971	5.592	----
10	6.214	6.835	7.456	8.078	8.699	9.321	9.942	10.563	11.185	11.806	10
20	12.427	13.049	13.670	14.292	14.913	15.534	16.156	16.777	17.398	18.020	20
30	18.641	19.263	19.884	20.505	21.127	21.748	22.369	22.991	23.612	24.233	30
40	24.855	25.476	26.098	26.719	27.340	27.962	28.583	29.204	29.826	30.447	40
50	31.069	31.690	32.311	32.933	33.554	34.175	34.797	35.418	36.040	36.661	50
60	37.282	37.904	38.525	39.146	39.768	40.389	41.010	41.632	42.253	42.875	60
70	43.496	44.117	44.739	45.360	45.981	46.603	47.224	47.846	48.467	49.088	70
80	49.710	50.331	50.952	51.574	52.195	52.817	53.438	54.059	54.681	55.302	80
90	55.923	56.545	57.166	57.788	58.409	59.03	59.652	60.273	60.894	61.516	90
100	62.137	62.758	63.380	64.001	64.623	65.244	65.865	66.487	67.108	67.729	100

**Area**

**Square inches to square centimeters**

in <sup>2</sup>	0	1	2	3	4	5	6	7	8	9	in <sup>2</sup>
	cm <sup>2</sup>	cm <sup>2</sup>	cm <sup>2</sup>	cm <sup>2</sup>	cm <sup>2</sup>	cm <sup>2</sup>	cm <sup>2</sup>	cm <sup>2</sup>	cm <sup>2</sup>	cm <sup>2</sup>	
----		6.452	12.903	19.355	25.806	32.258	38.710	45.161	51.613	58.065	----
10	64.516	70.968	77.419	83.871	90.323	96.774	103.226	109.677	116.129	122.581	10
20	129.032	135.484	141.935	148.387	154.839	161.290	167.742	174.194	180.645	187.097	20
30	193.548	200.000	206.452	212.903	219.355	225.806	232.258	238.710	245.161	251.613	30
40	258.065	264.516	270.968	277.419	283.871	290.323	296.774	303.226	309.677	316.129	40
50	322.581	329.032	335.484	341.935	348.387	354.839	361.290	367.742	374.194	380.645	50
60	387.097	393.548	400.000	406.452	412.903	419.355	425.806	432.258	438.710	445.161	60
70	451.613	458.065	464.516	470.968	477.419	483.871	490.323	496.774	503.226	509.677	70
80	516.129	522.581	529.032	535.484	541.935	548.387	554.839	561.290	567.742	574.194	80
90	580.645	587.097	593.548	600.000	606.452	612.903	619.355	625.806	632.258	638.710	90
100	645.161	651.613	658.065	664.516	670.968	677.419	683.871	690.323	696.774	703.226	100

INTRODUCTION

**Square centimeters to square inches**

cm <sup>2</sup>	0	1	2	3	4	5	6	7	8	9	cm <sup>2</sup>
	in <sup>2</sup>	in <sup>2</sup>	in <sup>2</sup>	in <sup>2</sup>	in <sup>2</sup>	in <sup>2</sup>	in <sup>2</sup>	in <sup>2</sup>	in <sup>2</sup>	in <sup>2</sup>	
----		0.155	0.310	0.465	0.620	0.775	0.930	1.085	1.240	1.395	----
10	1.550	1.705	1.860	2.015	2.170	2.325	2.480	2.635	2.790	2.945	10
20	3.100	3.255	3.410	3.565	3.720	3.875	4.030	4.185	4.340	4.495	20
30	4.650	4.805	4.960	5.115	5.270	5.425	5.580	5.735	5.890	6.045	30
40	6.200	6.355	6.510	6.665	6.820	6.975	7.130	7.285	7.440	7.595	40
50	7.750	7.905	8.060	8.215	8.370	8.525	8.680	8.835	8.990	9.145	50
60	9.300	9.455	9.610	9.765	9.920	10.075	10.230	10.385	10.540	10.695	60
70	10.850	11.005	11.160	11.315	11.470	11.625	11.780	11.935	12.090	12.245	70
80	12.400	12.555	12.710	12.865	13.020	13.175	13.330	13.485	13.640	13.795	80
90	13.950	14.105	14.260	14.415	14.570	14.725	14.880	15.035	15.190	15.345	90
100	15.500	15.655	15.810	15.965	16.120	16.275	16.430	16.585	16.740	16.895	100

**Volume**

**Cubic inches to cubic centimeters**

in <sup>3</sup>	0	1	2	3	4	5	6	7	8	9	in <sup>3</sup>
	cm <sup>3</sup> (cc)	cm <sup>3</sup> (cc)	cm <sup>3</sup> (cc)	cm <sup>3</sup> (cc)	cm <sup>3</sup> (cc)	cm <sup>3</sup> (cc)	cm <sup>3</sup> (cc)	cm <sup>3</sup> (cc)	cm <sup>3</sup> (cc)	cm <sup>3</sup> (cc)	
----		16.387	32.774	49.161	65.548	81.936	98.323	114.710	131.097	147.484	----
10	163.871	180.258	196.645	213.032	229.419	245.807	262.194	278.581	294.968	311.355	10
20	327.742	344.129	360.516	376.903	393.290	409.678	426.065	442.452	458.839	475.226	20
30	491.613	508.000	524.387	540.774	557.161	573.549	589.936	606.323	622.710	639.097	30
40	655.484	671.871	688.258	704.645	721.033	737.420	753.807	770.194	786.581	802.968	40
50	819.355	835.742	852.129	868.516	884.904	901.291	917.678	934.065	950.452	966.839	50
60	983.226	999.613	0	7	5	2	9	6	1114.323	0	60
70	1147.09	1163.48	1179.87	1196.25	1212.64	1229.03	1245.42	1261.80	1278.19	1294.58	70
	7	4	1	8	6	3	0	7	4	1	
80	1310.96	1327.35	1343.74	1360.13	1376.51	1392.90	1409.29	1425.67	1442.06	1458.45	80
	8	5	2	0	7	4	1	8	5	2	
90	1474.83	1491.22	1507.61	1524.00	1540.38	1556.77	1573.16	1589.54	1605.93	1622.32	90
	9	6	3	1	8	5	2	9	6	3	
100	1638.71	1655.09	1671.48	1687.87	1704.25	1720.64	1737.03	1753.42	1769.80	1786.19	100
	0	7	4	2	9	6	3	0	7	4	

**Cubic centimeters to cubic inches**

cm <sup>3</sup> (cc)	0	1	2	3	4	5	6	7	8	9	cm <sup>3</sup> (cc)
	in <sup>3</sup>	in <sup>3</sup>	in <sup>3</sup>	in <sup>3</sup>	in <sup>3</sup>	in <sup>3</sup>	in <sup>3</sup>	in <sup>3</sup>	in <sup>3</sup>	in <sup>3</sup>	
----		0.0610	0.1220	0.1831	0.2441	0.3051	0.3661	0.4272	0.4882	0.5492	----
10	0.6102	0.6713	0.7323	0.7933	0.8543	0.9154	0.9764	1.0374	1.0984	1.1594	10
20	1.2205	1.2815	1.3425	1.4035	1.4646	1.5256	1.5866	1.6476	1.7087	1.7697	20
30	1.8307	1.8917	1.9528	2.0138	2.0748	2.1358	2.1968	2.2579	2.3189	2.3799	30
40	2.4409	2.5020	2.5630	2.6240	2.6850	2.7461	2.8071	2.8681	2.9291	2.9902	40
50	3.0512	3.1122	3.1732	3.2343	3.2953	3.3563	3.4173	3.4784	3.5394	3.6004	50
60	3.6614	3.7224	3.7835	3.8445	3.9055	3.9665	4.0276	4.0886	4.1496	4.2106	60
70	4.2717	4.3327	4.3937	4.4547	4.5157	4.5768	4.6378	4.6988	4.7598	4.8209	70
80	4.8819	4.9429	5.0039	5.0650	5.1260	5.1870	5.2480	5.3091	5.3701	5.4311	80
90	5.4921	5.5531	5.6142	5.6752	5.7362	5.7972	5.8583	5.9193	5.9803	6.0413	90
100	6.1024	6.1634	6.2244	6.2854	6.3465	6.4075	6.4685	6.5295	6.5905	6.6516	100



INTRODUCTION

**Gallons (U.S) to liters**

U.S.-gal.	0	1	2	3	4	5	6	7	8	9	U.S.-gal.
	liters	liters	liters	liters	liters	liters	liters	liters	liters	liters	
----		3.7853	7.5707	11.3560	15.1413	18.9266	22.7120	26.4973	30.2826	34.0680	----
10	37.8533	41.6386	45.4239	49.2093	52.9946	56.7799	60.5653	64.3506	68.1359	71.9213	10
20	75.7066	79.4919	83.2772	87.0626	90.8479	94.6332	98.4186	102.203	105.989	109.774	20
30	113.559	117.345	121.130	124.915	128.701	132.486	136.271	140.057	143.842	147.627	30
40	151.413	155.198	158.983	162.769	166.554	170.339	174.125	177.910	181.695	185.481	40
50	189.266	193.051	196.837	200.622	204.407	208.193	211.978	215.763	219.549	223.334	50
60	227.119	230.905	234.690	238.475	242.261	246.046	249.831	253.617	257.402	261.187	60
70	264.973	268.758	272.543	276.329	280.114	283.899	287.685	291.470	295.255	299.041	70
80	302.826	306.611	310.397	314.182	317.967	321.753	325.538	329.323	333.109	336.894	80
90	340.679	344.464	348.250	352.035	355.820	359.606	363.391	367.176	370.962	374.747	90
100	378.532	382.318	386.103	389.888	393.674	397.459	401.244	405.030	408.815	412.600	100

**Liters to gallons (U.S)**

liters	0	1	2	3	4	5	6	7	8	9	liters
	U.S.gal.	U.S.gal.	U.S.gal.	U.S.gal.	U.S.gal.	U.S.gal.	U.S.gal.	U.S.gal.	U.S.gal.	U.S.gal.	
----		0.2642	0.5284	0.7925	1.0567	1.3209	1.5851	1.8492	2.1134	2.3776	----
10	2.6418	2.9060	3.1701	3.4343	3.6985	3.9627	4.2268	4.4910	4.7552	5.0194	10
20	5.2836	5.5477	5.8119	6.0761	6.3403	6.6044	6.8686	7.1328	7.3970	7.6612	20
30	7.9253	8.1895	8.4537	8.7179	8.9820	9.2462	9.5104	9.7746	10.0388	10.3029	30
40	10.5671	10.8313	11.0955	11.3596	11.6238	11.8880	12.1522	12.4164	12.6805	12.9447	40
50	13.2089	13.4731	13.7372	14.0014	14.2656	14.5298	14.7940	15.0581	15.3223	15.5865	50
60	15.8507	16.1148	16.3790	16.6432	16.9074	17.1716	17.4357	17.6999	17.9641	18.2283	60
70	18.4924	18.7566	19.0208	19.2850	19.5492	19.8133	20.0775	20.3417	20.6059	20.8700	70
80	21.1342	21.3984	21.6626	21.9268	22.1909	22.4551	22.7193	22.9835	23.2476	23.5118	80
90	23.7760	24.0402	24.3044	24.5685	24.8327	25.0969	25.3611	25.6252	25.8894	26.1536	90
100	26.4178	26.6820	26.9461	27.2103	27.4745	27.7387	28.0028	28.2670	28.5312	28.7954	100

INTRODUCTION

**Gallons (Imp.) to liters**

Imp-gal.	0	1	2	3	4	5	6	7	8	9	Imp-gal.
	liters	liters	liters	liters	liters	liters	liters	liters	liters	liters	
----		4.5455	9.0909	13.6364	18.1818	22.7273	27.2727	31.8182	36.3636	40.9091	----
10	45.4545	50.0000	54.5455	59.0909	63.6364	68.1818	72.7273	77.2727	81.8182	86.3636	10
20	90.9091	95.4545	0	5	9	4	8	3	7	2	20
30	136.3636	140.9091	145.4545	150.0000	154.5455	159.0909	163.6364	168.1818	172.7273	177.2727	30
40	181.8182	186.3637	190.9092	195.4547	200.0002	204.5457	209.0912	213.6367	218.1822	222.7277	40
50	227.2727	231.8182	236.3637	240.9092	245.4547	250.0002	254.5457	259.0912	263.6367	268.1822	50
60	272.7272	277.2727	281.8182	286.3637	290.9092	295.4547	300.0002	304.5457	309.0912	313.6367	60
70	318.1818	322.7273	327.2728	331.8183	336.3638	340.9093	345.4548	350.0003	354.5458	359.0913	70
80	363.6364	368.1819	372.7274	377.2729	381.8184	386.3639	390.9094	395.4549	400.0004	404.5459	80
90	409.0910	413.6365	418.1820	422.7275	427.2730	431.8185	436.3640	440.9095	445.4550	450.0005	90
100	454.5455	459.0910	463.6365	468.1820	472.7275	477.2730	481.8185	486.3640	490.9095	495.4550	100

**Liters to gallons (Imp.)**

liters	0	1	2	3	4	5	6	7	8	9	liters
	Imp-gal.	Imp-gal.	Imp-gal.	Imp-gal.	Imp-gal.	Imp-gal.	Imp-gal.	Imp-gal.	Imp.	Imp-gal.	
----		0.2200	0.4400	0.6600	0.8800	1.1000	1.3200	1.5400	1.7600	1.9800	----
10	2.2000	2.4200	2.6400	2.8600	3.0800	3.3000	3.5200	3.7400	3.9600	4.1800	10
20	4.4000	4.6200	4.8400	5.0600	5.2800	5.5000	5.7200	5.9400	6.1600	6.3800	20
30	6.6000	6.8200	7.0400	7.2600	7.4800	7.7000	7.9200	8.1400	8.3600	8.5800	30
40	8.8000	9.0200	9.2400	9.4600	9.6800	9.9000	10.1200	10.3400	10.5600	10.7800	40
50	11.0000	11.2200	11.4400	11.6600	11.8800	12.1000	12.3200	12.5400	12.7600	12.9800	50
60	13.2000	13.4200	13.6400	13.8600	14.0800	14.3000	14.5200	14.7400	14.9600	15.1800	60
70	15.4000	15.6200	15.8400	16.0600	16.2800	16.5000	16.7200	16.9400	17.1600	17.3800	70
80	17.6000	17.8200	18.0400	18.2600	18.4800	18.7000	18.9200	19.1400	19.3600	19.5800	80
90	19.8000	20.0200	20.2400	20.4600	20.6800	20.9000	21.1200	21.3400	21.5600	21.7800	90
100	22.0000	22.2200	22.4400	22.6600	22.8800	23.1000	23.3200	23.5400	23.7600	23.9800	100

**Weight**

**Pounds to kilograms**

lbs.	0	1	2	3	4	5	6	7	8	9	lbs.
	kg	kg	kg	kg	kg	kg	kg	kg	kg	kg	
----		0.454	0.907	1.361	1.814	2.268	2.722	3.175	3.629	4.082	----
10	4.536	4.989	5.443	5.897	6.350	6.804	7.257	7.711	8.165	8.618	10
20	9.072	9.525	9.979	10.433	10.886	11.340	11.793	12.247	12.701	13.154	20
30	13.608	14.061	14.515	14.968	15.422	15.876	16.329	16.783	17.236	17.690	30
40	18.144	18.597	19.051	19.504	19.958	20.412	20.865	21.319	21.772	22.226	40
50	22.680	23.133	23.587	24.040	24.494	24.947	25.401	25.855	26.308	26.762	50
60	27.215	27.669	28.123	28.576	29.030	29.483	29.937	30.391	30.844	31.298	60
70	31.751	32.205	32.658	33.112	33.566	34.019	34.473	34.926	35.380	35.834	70
80	36.287	36.741	37.194	37.648	38.102	38.555	39.009	39.462	39.916	40.370	80
90	40.823	41.277	41.730	42.184	42.637	43.091	43.545	43.998	44.452	44.905	90
100	45.359	45.813	46.266	46.720	47.173	47.627	48.081	48.534	48.988	49.441	100

INTRODUCTION

**Kilograms to pounds**

kg	0	1	2	3	4	5	6	7	8	9	kg
	lbs.	lbs.	lbs.	lbs.	lbs.	lbs.	lbs.	lbs.	lbs.	lbs.	
----		2.205	4.409	6.614	8.819	11.023	13.228	15.432	17.637	19.842	----
10	22.046	24.251	26.456	28.660	30.865	33.069	35.274	37.479	39.683	41.888	10
20	44.093	46.297	48.502	50.707	52.911	55.116	57.320	59.525	61.730	63.934	20
30	66.139	68.344	70.548	72.753	74.958	77.162	79.367	81.571	83.776	85.981	30
40	88.185	90.39	92.595	94.799	97.004	99.209	101.413	103.618	105.822	108.027	40
50	110.232	112.436	114.641	116.846	119.050	121.255	123.460	125.664	127.869	130.073	50
60	132.278	134.483	136.687	138.892	141.097	143.301	145.506	147.710	149.915	152.120	60
70	154.324	156.529	158.734	160.938	163.143	165.348	167.552	169.757	171.961	174.166	70
80	176.371	178.575	180.780	182.985	185.189	187.394	189.599	191.803	194.008	196.212	80
90	198.417	200.622	202.826	205.031	207.236	209.440	211.645	213.850	216.054	218.259	90
100	220.463	222.668	224.873	227.077	229.282	231.487	233.691	235.896	238.100	240.305	100

**Weight kilograms to newtons**

kgf	0	1	2	3	4	5	6	7	8	9	kg
	N	N	N	N	N	N	N	N	N	N	
----		9.81	19.61	29.42	39.23	49.03	58.84	68.65	78.45	88.26	----
10	98.07	107.87	117.68	127.49	137.29	147.10	156.91	166.71	176.52	186.33	10
20	196.13	205.94	215.75	225.55	235.36	245.17	254.97	264.78	274.59	284.39	20
30	294.20	304.01	313.81	323.62	333.43	343.23	353.04	362.85	372.65	382.46	30
40	392.27	402.07	411.88	421.69	431.49	441.30	451.11	460.91	470.72	480.53	40
50	490.33	500.14	509.95	519.75	529.56	539.37	549.17	558.98	568.79	578.59	50
60	588.40	598.21	608.01	617.82	627.63	637.43	647.24	657.05	666.85	676.66	60
70	686.47	696.27	706.08	715.89	725.69	735.50	745.31	755.11	764.92	774.73	70
80	784.53	794.34	804.15	813.95	823.76	833.57	843.37	853.18	862.99	872.79	80
90	882.60	892.41	902.21	912.02	921.83	931.63	941.44	951.25	961.05	970.86	90
100	980.67	990.47	1000.28	1010.08	1019.89	1029.70	1039.5	1049.31	1059.12	1068.92	100

**Newtons to weight kilograms**

N	0	1	2	3	4	5	6	7	8	9	N
	kgf	kgf	kgf	kgf	kgf	kgf	kgf	kgf	kgf	kgf	
----		0.1020	0.2039	0.3059	0.4079	0.5099	0.6118	0.7138	0.8158	0.9177	----
10	1.0197	1.1217	1.2237	1.3256	1.4276	1.5296	1.6315	1.7335	1.8355	1.9375	10
20	2.0394	2.1414	2.2434	2.3453	2.4473	2.5493	2.6513	2.7532	2.8552	2.9572	20
30	3.0591	3.1611	3.2631	3.3651	3.4670	3.5690	3.6710	3.7729	3.8749	3.9769	30
40	4.0789	4.1808	4.2828	4.3848	4.4868	4.5887	4.6907	4.7927	4.8946	4.9966	40
50	5.0986	5.2006	5.3025	5.4045	5.5065	5.6084	5.7104	5.8124	5.9144	6.0163	50
60	6.1183	6.2203	6.3222	6.4242	6.5262	6.6282	6.7301	6.8321	6.9341	7.0360	60
70	7.1380	7.2400	7.3420	7.4439	7.5459	7.6479	7.7498	7.8518	7.9538	8.0558	70
80	8.1577	8.2597	8.3617	8.4636	8.5656	8.6676	8.7696	8.8715	8.9735	9.0755	80
90	9.1774	9.2794	9.3814	9.4834	9.5853	9.6873	9.7893	9.8912	9.9932	10.0952	90
100	10.1972	10.2991	10.4011	10.5031	10.6050	10.7070	10.8090	10.9110	11.0129	11.1149	100

INTRODUCTION

**Pressure**

**Weight pounds/square inch to weight kilograms/square centimeter**

lbf/in <sup>2</sup>	0	1	2	3	4	5	6	7	8	9	lbf/in <sup>2</sup>
(psi)	kgf/cm <sup>2</sup>	kgf/cm <sup>2</sup>	kgf/cm <sup>2</sup>	kgf/cm <sup>2</sup>	kgf/cm <sup>2</sup>	kgf/cm <sup>2</sup>	kgf/cm <sup>2</sup>	kgf/cm <sup>2</sup>	kgf/cm <sup>2</sup>	kgf/cm <sup>2</sup>	(psi)
----		0.0703	0.1406	0.2109	0.2812	0.3515	0.4218	0.4921	0.5624	0.6327	----
10	0.7030	0.7733	0.8436	0.9139	0.9842	1.0545	1.1248	1.1951	1.2654	1.3357	10
20	1.4060	1.4763	1.5466	1.6169	1.6872	1.7575	1.8278	1.8981	1.9684	2.0387	20
30	2.1090	2.1793	2.2496	2.3199	2.3902	2.4605	2.5308	2.6011	2.6714	2.7417	30
40	2.8120	2.8823	2.9526	3.0229	3.0932	3.1635	3.2338	3.3041	3.3744	3.4447	40
50	3.5150	3.5853	3.6556	3.7259	3.7962	3.8665	3.9368	4.0071	4.0774	4.1477	50
60	4.2180	4.2883	4.3586	4.4289	4.4992	4.5695	4.6397	4.7100	4.7803	4.8506	60
70	4.9209	4.9912	5.0615	5.1318	5.2021	5.2724	5.3427	5.4130	5.4833	5.5536	70
80	5.6239	5.6942	5.7645	5.8348	5.9051	5.9754	6.0457	6.1160	6.1863	6.2566	80
90	6.3269	6.3972	6.4675	6.5378	6.6081	6.6784	6.7487	6.8190	6.8893	6.9596	90
100	7.0299	7.1002	7.1705	7.2408	7.3111	7.3814	7.4517	7.5220	7.5923	7.6626	100

**Weight kilograms/square centimeter to weight pounds/square inch**

kgf/cm <sup>2</sup>	0	1	2	3	4	5	6	7	8	9	kgf/cm <sup>2</sup>
	lbf/in <sup>2</sup> (psi)	lbf/in <sup>2</sup> (psi)	lbf/in <sup>2</sup> (psi)	lbf/in <sup>2</sup> (psi)	lbf/in <sup>2</sup> (psi)	lbf/in <sup>2</sup> (psi)	lbf/in <sup>2</sup> (psi)	lbf/in <sup>2</sup> (psi)	lbf/in <sup>2</sup> (psi)	lbf/in <sup>2</sup> (psi)	
----		14.22	28.45	42.67	56.90	71.12	85.35	99.57	113.80	128.02	----
10	142.25	156.47	170.70	184.92	199.15	213.37	227.60	241.82	256.05	270.27	10
20	284.50	298.72	312.95	327.17	341.40	355.62	369.85	384.07	398.30	412.52	20
30	426.75	440.97	455.20	469.42	483.65	497.87	512.10	526.32	540.55	554.77	30
40	569.00	583.22	597.45	611.67	625.90	640.12	654.35	668.57	682.80	697.02	40
50	711.25	725.47	739.70	753.92	768.14	782.37	796.59	810.82	825.04	839.27	50
60	853.49	867.72	881.94	896.17	910.39	924.62	938.84	953.07	967.29	981.52	60
70	995.74	1009.97	1024.19	1038.42	1052.64	1066.87	1081.09	1095.32	1109.54	1123.77	70
80	1137.99	1152.22	1166.44	1180.67	1194.89	1209.12	1223.34	1237.57	1251.79	1266.02	80
90	1280.24	1294.47	1308.69	1322.92	1337.14	1351.37	1365.59	1379.82	1394.04	1408.27	90
100	1422.49	1436.72	1450.94	1465.17	1479.39	1493.62	1507.84	1522.06	1536.29	1550.51	100

**Weight kilograms/square centimeter to kilopascals**

kgf/cm <sup>2</sup>	0	1	2	3	4	5	6	7	8	9	kgf/cm <sup>2</sup>
	kpa	kpa	kpa	kpa	kpa	kpa	kpa	kpa	kpa	kpa	
----		98.1	196.1	294.2	392.3	490.3	588.4	686.5	784.5	882.6	----
10	980.7	1078.7	1176.8	1274.9	1372.9	1471.0	1569.1	1667.1	1765.2	1863.3	10
20	1961.3	2059.4	2157.5	2255.5	2353.6	2451.7	2549.7	2647.8	2745.9	2843.9	20
30	2942.0	3040.1	3138.1	3236.2	3334.3	3432.3	3530.4	3628.5	3726.5	3824.6	30
40	3922.7	4020.7	4118.8	4216.9	4314.9	4413.0	4511.1	4609.1	4707.2	4805.3	40
50	4903.3	5001.4	5099.5	5197.5	5295.6	5393.7	5491.7	5589.8	5687.9	5785.9	50
60	5884.0	5982.1	6080.1	6178.2	6276.3	6374.3	6472.4	6570.5	6668.5	6766.6	60
70	6864.7	6962.7	7060.8	7158.9	7256.9	7355.0	7453.1	7551.1	7649.2	7747.3	70
80	7845.3	7943.4	8041.5	8139.5	8237.6	8335.7	8433.7	8531.8	8629.9	8727.9	80
90	8826.0	8924.1	9022.1	9120.2	9218.3	9316.3	9414.4	9512.5	9610.5	9708.6	90
100	9806.7	9904.7	10002.8	10100.8	10198.9	10297	10395.0	10493.1	10591.2	10689.2	100

INTRODUCTION

**Kilopascals to weight kilograms/square centimeter**

kpa	0	100	200	300	400	500	600	700	800	900	kpa
	kgf/cm <sup>2</sup>	kgf/cm <sup>2</sup>	kgf/cm <sup>2</sup>	kgf/cm <sup>2</sup>	kgf/cm <sup>2</sup>	kgf/cm <sup>2</sup>	kgf/cm <sup>2</sup>	kgf/cm <sup>2</sup>	kgf/cm <sup>2</sup>	kgf/cm <sup>2</sup>	
----		1.020	2.039	3.059	4.079	5.099	6.118	7.138	8.158	9.177	----
1000	10.197	11.217	12.237	13.256	14.276	15.296	16.315	17.335	18.355	19.375	1000
2000	20.394	21.414	22.434	23.453	24.473	25.493	26.513	27.532	28.552	29.572	2000
3000	30.591	31.611	32.631	33.651	34.670	35.690	36.710	37.729	38.749	39.769	3000
4000	40.789	41.808	42.828	43.848	44.868	45.887	46.907	47.927	48.946	49.966	4000
5000	50.986	52.006	53.025	54.045	55.065	56.084	57.104	58.124	59.144	60.163	5000
6000	61.183	62.203	63.222	64.242	65.262	66.282	67.301	68.321	69.341	70.360	6000
7000	71.380	72.400	73.420	74.439	75.459	76.479	77.498	78.518	79.538	80.558	7000
8000	81.577	82.597	83.617	84.636	85.656	86.676	87.696	88.715	89.735	90.755	8000
9000	91.774	92.794	93.814	94.834	95.853	96.873	97.893	98.912	99.932	100.952	9000
10000	101.972	102.991	104.011	105.031	106.050	107.070	108.090	109.110	110.129	111.149	10000

**Torque**

**Feet weight pounds to weight kilogram meters**

lbf.ft	0	1	2	3	4	5	6	7	8	9	lbf.ft
	kgf-m	kgf-m	kgf-m	kgf-m	kgf-m	kgf-m	kgf-m	kgf-m	kgf-m	kgf-m	
----		0.138	0.277	0.415	0.553	0.692	0.830	0.969	1.107	1.245	----
10	1.384	1.522	1.660	1.799	1.937	2.075	2.214	2.352	2.490	2.629	10
20	2.767	2.906	3.044	3.182	3.321	3.459	3.597	3.736	3.874	4.012	20
30	4.151	4.289	4.428	4.566	4.704	4.843	4.981	5.119	5.258	5.396	30
40	5.534	5.673	5.811	5.949	6.088	6.226	6.365	6.503	6.641	6.780	40
50	6.918	7.056	7.195	7.333	7.471	7.610	7.748	7.887	8.025	8.163	50
60	8.302	8.440	8.578	8.717	8.855	8.993	9.132	9.270	9.409	9.547	60
70	9.685	9.824	9.962	10.100	10.239	10.377	10.515	10.654	10.792	10.930	70
80	11.069	11.207	11.346	11.484	11.622	11.761	11.899	12.037	12.176	12.314	80
90	12.452	12.591	12.729	12.868	13.006	13.144	13.283	13.421	13.559	13.698	90
100	13.836	13.974	14.113	14.251	14.389	14.528	14.666	14.805	14.943	15.081	100

**Weight kilogram meters to feet weight pounds**

kgf-m	0	1	2	3	4	5	6	7	8	9	kgf-m
	lbf.ft	lbf.ft	lbf.ft	lbf.ft	lbf.ft	lbf.ft	lbf.ft	lbf.ft	lbf.ft	lbf.ft	
----		7.228	14.455	21.683	28.910	36.138	43.365	50.593	57.820	65.048	----
10	72.275	79.503	86.730	93.958	101.185	108.413	115.640	122.868	130.095	137.323	10
20	144.550	151.778	159.005	166.233	173.460	180.688	187.915	195.143	202.370	209.598	20
30	216.825	224.053	231.280	238.508	245.735	252.963	260.190	267.418	274.645	281.873	30
40	289.100	296.328	303.555	310.783	318.010	325.238	332.465	339.693	346.920	354.148	40
50	361.375	368.603	375.830	383.058	390.285	397.513	404.740	411.968	419.195	426.423	50
60	433.650	440.878	448.105	455.333	462.560	469.788	477.015	484.243	491.470	498.698	60
70	505.925	513.153	520.380	527.608	534.835	542.063	549.290	556.518	563.745	570.973	70
80	578.200	585.428	592.655	599.883	607.110	614.338	621.565	628.793	636.020	643.248	80
90	650.475	657.703	664.930	672.158	679.385	686.613	693.840	701.068	708.295	715.523	90
100	722.750	729.978	737.205	744.433	751.660	758.888	766.115	773.343	780.570	787.798	100

INTRODUCTION

**Weight kilogram meters to Newton meters**

kgf·m	0	1	2	3	4	5	6	7	8	9	kgf·m
	N·m	N·m	N·m	N·m	N·m	N·m	N·m	N·m	N·m	N·m	
----		9.81	19.61	29.42	39.23	49.03	58.84	68.65	78.45	88.26	----
10	98.07	107.87	117.68	127.49	137.29	147.10	156.91	166.71	176.52	186.33	10
20	196.13	205.94	215.75	225.55	235.36	245.17	254.97	264.78	274.59	284.39	20
30	294.20	304.01	313.81	323.62	333.43	343.23	353.04	362.85	372.65	382.46	30
40	392.27	402.07	411.88	421.69	431.49	441.30	451.11	460.91	470.72	480.53	40
50	490.33	500.14	509.95	519.75	529.56	539.37	549.17	558.98	568.79	578.59	50
60	588.40	598.21	608.01	617.82	627.63	637.43	647.24	657.05	666.85	676.66	60
70	686.47	696.27	706.08	715.89	725.69	735.50	745.31	755.11	764.92	774.73	70
80	784.53	794.34	804.15	813.95	823.76	833.57	843.37	853.18	862.99	872.79	80
90	882.60	892.41	902.21	912.02	921.83	931.63	941.44	951.25	961.05	970.86	90
100	980.67	990.47	1000.28	1010.08	1019.89	1029.70	1039.5	1049.31	1059.12	1068.92	100

**Newton meters to weight kilogram meters**

N·m	0	10	20	30	40	50	60	70	80	90	N·m
	kgf·m	kgf·m	kgf·m	kgf·m	kgf·m	kgf·m	kgf·m	kgf·m	kgf·m	kgf·m	
----		1.020	2.039	3.059	4.079	5.099	6.118	7.138	8.158	9.177	----
100	10.197	11.217	12.237	13.256	14.276	15.296	16.315	17.335	18.355	19.375	10
200	20.394	21.414	22.434	23.453	24.473	25.493	26.513	27.532	28.552	29.572	20
300	30.591	31.611	32.631	33.651	34.670	35.690	36.710	37.729	38.749	39.769	30
400	40.789	41.808	42.828	43.848	44.868	45.887	46.907	47.927	48.946	49.966	40
500	50.986	52.006	53.025	54.045	55.065	56.084	57.104	58.124	59.144	60.163	50
600	61.183	62.203	63.222	64.242	65.262	66.282	67.301	68.321	69.341	70.360	60
700	71.380	72.400	73.420	74.439	75.459	76.479	77.498	78.518	79.538	80.558	70
800	81.577	82.597	83.617	84.636	85.656	86.676	87.696	88.715	89.735	90.755	80
900	91.774	92.794	93.814	94.834	95.853	96.873	97.893	98.912	99.932	100.952	90
1000	101.972	102.991	104.011	105.031	106.050	107.070	108.090	109.110	110.129	111.149	100

---

**Temperature**
**Fahrenheit to centigrade**

°F	°C	°F	°C	°F	°C	°F	°C	°F	°C	°F	°C	°F	°C	°F	°C
-60	-51.1	2	-18.9	56	13.3	114	45.6	172	77.8	230	110	288	142.2	346	174.4
-58	-50	0	-17.8	58	14.4	116	46.7	174	78.9	232	111.1	290	143.3	348	175.6
-56	-48.9	2	-16.7	60	15.6	118	47.8	176	80.0	234	112.2	292	144.4	350	176.7
-54	-47.8	4	-15.6	62	16.7	120	48.9	178	81.1	236	113.3	294	145.6	352	177.8
-52	-46.7	6	-14.4	64	17.8	122	50.0	180	82.2	238	114.4	296	146.7	354	178.9
-50	-45.6	8	-13.3	66	18.9	124	51.1	182	83.3	240	115.6	298	147.8	356	180
-48	-44.4	10	-12.2	68	20	126	52.2	184	84.4	242	116.7	300	148.9	358	181.1
-46	-43.3	12	-11.1	70	21.1	128	53.3	186	85.6	244	117.8	302	150	360	182.2
-44	-42.2	14	-10	72	22.2	130	54.4	188	86.7	246	118.9	304	151.1	362	183.3
-42	-41.1	16	-8.9	74	23.3	132	55.6	190	87.8	248	120	306	152.2	364	184.4
-40	-40.0	18	-7.8	76	24.4	134	56.7	192	88.9	250	121.1	308	153.3	366	185.6
-38	-38.9	20	-6.7	78	25.6	136	57.8	194	90.0	252	122.2	310	154.4	368	186.7
-36	-37.8	22	-5.6	80	26.7	138	58.9	196	91.1	254	123.3	312	155.6	370	187.8
-34	-36.7	24	-4.4	82	27.8	140	60	198	92.2	256	124.4	314	156.7	372	188.9
-32	-35.6	26	-3.3	84	28.9	142	61.1	200	93.3	258	125.6	316	157.8	374	190.0
-30	-34.4	28	-2.2	86	30.0	144	62.2	202	94.4	260	126.7	318	158.9	376	191.1
-28	-33.3	30	-1.1	88	31.1	146	63.3	204	95.6	262	127.8	320	160	378	192.2
-26	-32.2	32	0.0	90	32.2	148	64.4	206	96.7	264	128.9	322	161.1	380	193.3
-24	-31.1	34	1.1	92	33.3	150	65.6	208	97.8	266	130.0	324	162.2	382	194.4
-22	-30.0	36	2.2	94	34.4	152	66.7	210	98.9	268	131.1	326	163.3	384	195.6
-20	-28.9	38	3.3	96	35.6	154	67.8	212	100.0	270	132.2	328	164.4	386	196.7
-18	-27.8	40	4.4	98	36.7	156	68.9	214	101.1	272	133.3	330	165.6	388	197.8
-16	-26.7	42	5.6	100	37.8	158	70.0	216	102.2	274	134.4	332	166.7	390	198.9
-14	-25.6	44	6.7	102	38.9	160	71.1	218	103.3	276	135.6	334	167.8	392	200
-12	-24.4	46	7.8	104	40.0	162	72.2	220	104.4	278	136.7	336	168.9	400	204.4
-10	-23.3	48	8.9	106	41.1	164	73.3	222	105.6	280	137.8	338	170.0	410	210.0
-8	-22.2	50	10.0	108	42.2	166	74.4	224	106.7	282	138.9	340	171.1	420	215.6
-6	-21.1	52	11.1	110	43.3	168	75.6	226	107.8	284	140.0	342	172.2	430	221.1
-4	-20.0	54	12.2	112	44.4	170	76.7	228	108.9	286	141.1	344	173.3	440	226.7

INTRODUCTION

Centigrade to fahrenheit

°C	°F	°C	°F	°C	°F	°C	°F	°C	°F	°C	°F	°C	°F	°C	°F
-50	-58.0	-18	-0.4	14	57.2	46	114.8	78	172.4	110	230.0	142	287.6	174	345.2
-49	-56.2	-17	1.4	15	59.0	47	116.6	79	174.2	111	231.8	143	289.4	175	347.0
-48	-54.4	-16	3.2	16	60.8	48	118.4	80	176.0	112	233.6	144	291.2	176	348.8
-47	-52.6	-15	5.0	17	62.6	49	120.2	81	177.8	113	235.4	145	293.0	177	350.6
-46	-50.8	-14	6.8	18	64.4	50	122.0	82	179.6	114	237.2	146	294.8	178	352.4
-45	-49.0	-13	8.6	19	66.2	51	123.8	83	181.4	115	239.0	147	296.6	179	354.2
-44	-47.2	-12	10.4	20	68.0	52	125.6	84	183.2	116	240.8	148	298.4	180	356.0
-43	-45.4	-11	12.2	21	69.8	53	127.4	85	185.0	117	242.6	149	300.2	181	357.8
-42	-43.6	-10	14.0	22	71.6	54	129.2	86	186.8	118	244.4	150	302.0	182	359.6
-41	-41.8	-9	15.8	23	73.4	55	131.0	87	188.6	119	246.2	151	303.8	183	361.4
-40	-40.0	-8	17.6	24	75.2	56	132.8	88	190.4	120	248.0	152	305.6	184	363.2
-39	-38.2	-7	19.4	25	77.0	57	134.6	89	192.2	121	249.8	153	307.4	185	365.0
-38	-36.4	-6	21.2	26	78.8	58	136.4	90	194.0	122	251.6	154	309.2	186	366.8
-37	-34.6	-5	23.0	27	80.6	59	138.2	91	195.8	123	253.4	155	311.0	187	368.6
-36	-32.8	-4	24.8	28	82.4	60	140.0	92	197.6	124	255.2	156	312.8	188	370.4
-35	-31.0	-3	26.6	29	84.2	61	141.8	93	199.4	125	257.0	157	314.6	189	372.2
-34	-29.2	-2	28.4	30	86.0	62	143.6	94	201.2	126	258.8	158	316.4	190	374.0
-33	-27.4	-1	30.2	31	87.8	63	145.4	95	203.0	127	260.6	159	318.2	191	375.8
-32	-25.6	0	32.0	32	89.6	64	147.2	96	204.8	128	262.4	160	320.0	192	377.6
-31	-23.8	1	33.8	33	91.4	65	149.0	97	206.6	129	264.2	161	321.8	193	379.4
-30	-22.0	2	35.6	34	93.2	66	150.8	98	208.4	130	266.0	162	323.6	194	381.2
-29	-20.2	3	37.4	35	95.0	67	152.6	99	210.2	131	267.8	163	325.4	195	383.0
-28	-18.4	4	39.2	36	96.8	68	154.4	100	212.0	132	269.6	164	327.2	196	384.8
-27	-16.6	5	41.0	37	98.6	69	156.2	101	213.8	133	271.4	165	329.0	197	386.6
-26	-14.8	6	42.8	38	100.4	70	158.0	102	215.6	134	273.2	166	330.8	198	388.4
-25	-13.0	7	44.6	39	102.2	71	159.8	103	217.4	135	275.0	167	332.6	199	390.2
-24	-11.2	8	46.4	40	104.0	72	161.6	104	219.2	136	276.8	168	334.4	200	392.0
-23	-9.4	9	48.2	41	105.8	73	163.4	105	221.0	137	278.6	169	336.2	210	410.0
-22	-8	10	50.0	42	107.6	74	165.2	106	222.8	138	280.4	170	338.0	220	428.0
-21	-6	11	51.8	43	109.4	75	167.0	107	224.6	139	282.2	171	339.8	230	446.0
-20	-4	12	53.6	44	111.2	76	168.8	108	226.4	140	284.0	172	341.6	240	464.0
-19	-2	13	55.4	45	113.0	77	170.6	109	228.2	141	285.8	173	343.4	250	482.0



## Consumables

By using appropriate lubricants the excavator can operate in ambient temperatures ranging from **-20 °C (-4 °F)** to **45 °C (113 °F)**. Refer to the list of lubricants contained in this manual.

**NOTICE:** *When operating the machine in ambient temperatures outside the above mentioned range, consult your CASE CONSTRUCTION Dealer for specific fluids to be used.*

### Hydraulic fluid

**CASE AKCELA HYDRAULIC EXCAVATOR FLUID  
MAT3509** ( ISO 6743 -L-HV 46 )

Biodegradable fluid:

**CASE AKCELA HYDRAULIC EXCAVATOR FLUID BIO  
MAT3509** ( ISO 6743 -L-HS 46 )

When changing over the hydraulic fluid in the system from mineral oil to biodegradable oil proceed as follows:

1. Drain the system completely.
2. Flush the system with biodegradable oil in order to minimize the contamination from residual mineral oil: guideline provided in ISO 15380 target no more than **2 %** of mineral oil remaining in the system after fluid changeover.
3. Replace the suction filter, the hydraulic return filter and the pilot line filter.
4. Make the final fill with biodegradable oil.

**NOTICE:** *the hydraulic return filter and the pilot line filter shall be replaced **50 h** after the change over to the biodegradable hydraulic fluid.*

### Transmission component oil

**CASE AKCELA GEAR 135 H EP 80W-90  
MS 1316, SAE 80W/90, API GL-5**

### Grease

**CASE AKCELA 251H EP MULTI-PURPOSE GREASE  
NLGI 2**

### Engine oil

**CASE AKCELA UNITEK 10W-40  
MAT3521** ( SAE 10W40, ACEA E9, API CJ-4 )

### Engine coolant

**CASE AKCELA PREMIUM ANTI-FREEZE  
MAT3620** (ASTM D 6210 Type 1-FF)

**NOTICE:** *CASE AKCELA PREMIUM ANTI-FREEZE is concentrate and shall be mixed with water before filling the cooling system. Refer to the following Antifreeze/water mixture chart.*

Minimum ambient temperature	-20 °C (-4 °F)	-25 °C (-13 °F)	-30 °C (-22 °F)	-40 °C (-40 °F)
Antifreeze	40 %	45 %	50 %	60 %
Water	60 %	55 %	50 %	40 %

**NOTICE:** *do not mix coolants of a different origin or brand. The same product must be used when topping up the system.*

## Fuel

Use only Ultra-Low Sulphur Diesel (S10) that meets **EN 590** specifications.

Using other types of fuel may lead to stalled engine output or deterioration in fuel economy.

**NOTICE:** *The warranty shall be invalid if any serious defect is caused by usage of any other fuel. Using fuel other than recommended may cause damage to the fuel injection pump, injector, DOC (Diesel Oxidation Catalyst), and other fuel supply system or the engine. CASE CONSTRUCTION may not be responsible to any of such damages.*

If the temperature drops below the fuel cloud point, output deficiency or engine start problems may occur due to wax crystals.

**NOTICE:** *If operating in severe winter climate, consult the fuel supplier or the CASE CONSTRUCTION dealer for specific diesel fuel according to the **EN 590** to be used.*

Conditions applicable to diesel fuel. The diesel fuel used must:

- be free from dust particles, even minute ones,
- have the proper viscosity,
- have a high cetane number,
- present great fluidity at low temperatures,
- have low sulphur content,
- have very little residual carbon.

Recommended conditions that can be applied to diesel fuel:

- JIS (Japanese Industrial Standard): No. 2
- DIN (Deutsche Industrie Normen): DIN 51601
- SAE (Society of Automotive Engineers) based on SAE-J-313C : No. 2-D
- BS (British Standard) based on B-1S/2869-1970: Class A
- EN 590 (less than 10 ppm sulfur)
- Or fuel specified by the country using these standards and this machine.

It is recommended that the following safety information be considered in order to prevent damage to the engine fuel supply system.

- Some fuel suppliers mix old engine oil and diesel fuel.
- Makers of larger engine permit the use of this kind of fuel.
- However, do not use diesel fuel contaminated with engine oil in customer's engines.
- Not only will this fuel damage the engine, it may also have a negative impact on the exhaust gas purification function.
- Before using diesel fuel, confirm with the supplier whether the fuel complies with the above specifications.

**NOTICE:** *consult the supplier or the CASE CONSTRUCTION Dealer regarding appropriate use of fuel additives.*

**NOTICE:** *in order to prevent condensation during cold weather, fill the fuel tank to full after the completing the day's work.*

Fuel storage:

Long storage can lead to the accumulation of impurities and condensation in the fuel. Engine trouble can often be traced to the presence of water in the fuel. The storage tank must be placed outside and the temperature of the fuel should be kept as low as possible. Drain off water and impurities regularly.

## **Environment and ecology**

Before carrying out any maintenance operation on this machine and before disposing of used fluids or lubricants, always think of the environment. Never throw oil or fluid on the ground and never place it in leaking receptacles.

Consult your local ecological recycling center or your CASE CONSTRUCTION Dealer to obtain information on the correct method of disposing of these lubricants.

The following are recommendations which may be of assistance:

- Become acquainted with and ensure that you understand the relative legislation applicable to your country.
- Where no legislation exists, obtain information from suppliers of oils, filters, batteries, fuels, antifreeze, cleaning agents, etc., with regard to their effect on man and nature and how to safely store, use and dispose of these substances.
- Local Environmental Agency will, in many cases, be able to help you as well.

---

## Capacities

Engine	<b>23.1 L (6.1 US gal)</b>
Cooling system	<b>31.4 l (8.30 US gal)</b>
Fuel tank	<b>410 l (108.31 US gal)</b>
<b>DEF/AdBlue®</b> tank	<b>120 l (31.7 US gal)</b>
Hydraulic system	Whole system: <b>250 l (66.04 US gal)</b>
	Tank: <b>147 l (38.83 US gal)</b>
Travel reduction units	<b>5.0 L (1.3 US gal) x2</b>
Swing unit	<b>9.7 L (2.6 US gal)</b>
Turntable teeth	<b>14.5 kg (32.0 lb)</b>

## Abbreviation

Abbreviation	Explanation
A/C	Air-conditioner
A/D	Analog/Digital
ABDC	After bottom dead center
AC	Alternating current
ACC	Accessories
ACG	Alternating current generator
ACT	Actuator
API	American Petroleum Institute
ASM	Assembly
ATDC	After top dead center
ATF	Automatic transmission fluid
Drilled hole B	Notch hole bolt
Eye B	Eyebolt
Full threaded B	Full threaded bolt
Hexagon socket head B	Hexagon socket head bolt
High-strength B	High-strength bolt
Reamer B	Reamer bolt
B+	Battery positive
BAT	Battery
BBDC	Before bottom dead center
BKT	Bracket
BRG	Bearing
BTDC	Before top dead center
C/B	Circuit breaker
C/U	Control unit
C. RAIL	Common rail
CAL	Calibration
CAN	Type of control unit communication format (controller area network)
CCD	Charged-coupled device
CCV	Coolant control valve
CCW	Counterclockwise
CFG	Configuration
CHK	Check
CKP	Crankshaft position
CMP	Camshaft position
CN.	Connector
CO	Carbon monoxide
CPU	Central processing unit
CW	Clockwise
DC	Direct current
DCU	Dosing control unit
DEF/AdBlue®	Urea solution
DI	Direct injection type
DIAG	Diagnosis
DLC	Data link connector
DMM	Digital multi-meter
DOC	Diesel oxidation catalyst
DPD	Diesel particulate diffuser
DTC	Diagnostic trouble code
ECM	Engine controller module
ECT	Engine coolant temperature
ECU	Engine control unit
EEPROM	Electrically erasable programmable read-only memory
EGR	Exhaust gas recirculation

INTRODUCTION

Abbreviation	Explanation
EMI	Electromagnetic interference
EMPS	Engine module programming system
ENG	Engine
EPF	Engine protection feature
EVRV	Electric vacuum regulating valve
EXH	Exhaust gas
F/B	Feedback
F/C	Fuel cut
F/L	Fusible link
FLW	Fusible link wire
FRP	Fiber-reinforced plastic
FRT	Front
FT	Fuel temperature
FVM	Field view monitor
FWD	Forward
GEN	Generator
GND	Ground
GPS	Global Positioning System
HBCV	Hose burst check valve
HC	Hydrocarbon
HO2S	Heated O2 sensor
HR	Hour
HRD	High reach demolition model
HYD.	Hydraulic mechanism
IAC	Idle air control
IAT	Intake air temperature
IC	Integrated circuit
ID Plate	Decal and ID plate
IMT	Intake manifold temperature
INL	Suction air
INJ	Injection
ISO	International Standardization Organization
ISP	Intake shutter position
ITP	Intake throttle position
J/C	Joint connector
JIS	Japanese Industrial Standards
KW	Type of communication format (keyword)
LED	Light-emitting diode
LH	Left
LLC	Long-life coolant
LM	Lifting magnet
M/A	Motor actuator
M/V	Electromagnetic valve
MAF	Mass air flow
MAP	Manifold air pressure
Max	Maximum
MCM	Main control module
MIL	Malfunction indicator lamp (diagnosis)
milli-amp	Current
Min	Minimum
MPU	Micro-processing unit
High-strength N	High-strength nut
NC	Normally closed
NO	Normally open
NOx	Nitrogen oxide

## INTRODUCTION

Abbreviation	Explanation
N-TDC	Speed at top dead center
O2S	O2 sensor
OBD	On-board diagnosis
OEM	Original equipment manufacturing
OPT	Option
OT	Oil temperature
P/L	Pilot lamp
P.C.D.	Pitch diameter
PCV	Pump control valve/positive crankcase ventilation
P-I	Proportional - integral
PM	Particulate matter
PTO	Power take-off
PWM	Pulse width modulated wave
QOS	Quick preheat unit
QWS	Quick warm up system
R/L	Relay
RAM	Random access memory
REF	Reference
RH	Right
ROM	Read-only memory
ROPS	Roll over protective structure
RP	Rail pressure
Rr	Rear
RWD	Rearward
Flush head S	Flush head Screw
Phillips pan head S	Phillips pan head Screw
Screw tapping S	Screw tapping Screw
S/A	Subassembly
SAE	Society of Automotive Engineers
SBF	Slow blow fuse
SCR	Selective Catalytic Reduction
SCV	Suction control valve
SIG	Signal
SLD	Shield
SOL	Solenoid
SP pin	Special pin
ST	Starter/start
STD	Standard
SW	Switch
TDC	Top dead center
TEMP	Temperature
TH.	Throttle valve
TP	Throttle position
UART	Universal asynchronous receiver-transmitter
VB	Battery voltage
VGS Turbo	Variable geometry system turbo
High-strength W	High-strength washer
Outer-tooth W	Outer-tooth washer
W/H	Wire, harness
W/L	Warning light
W/S	Welded splice
WOT	Wide open throttle

## Product identification

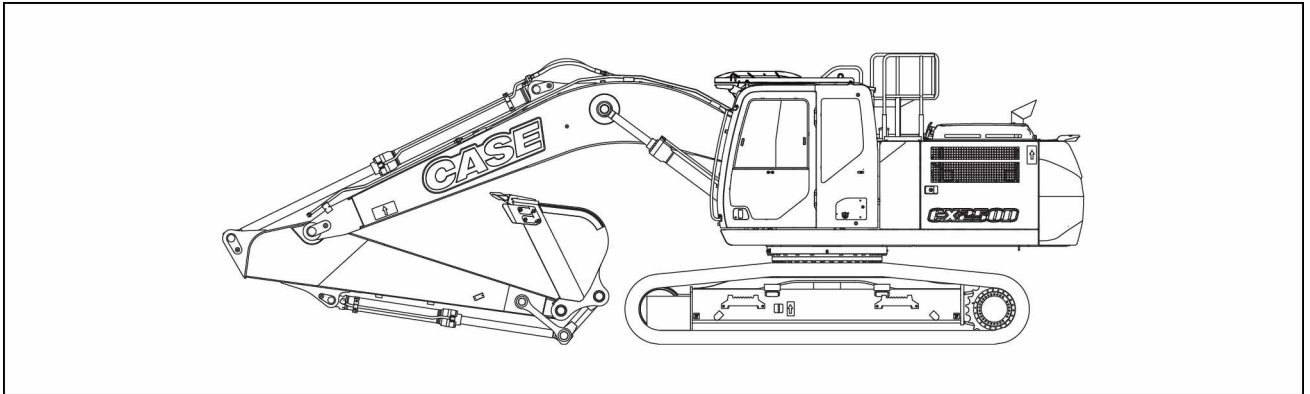

SMIL15CEX4055EA 1

**Standard version**

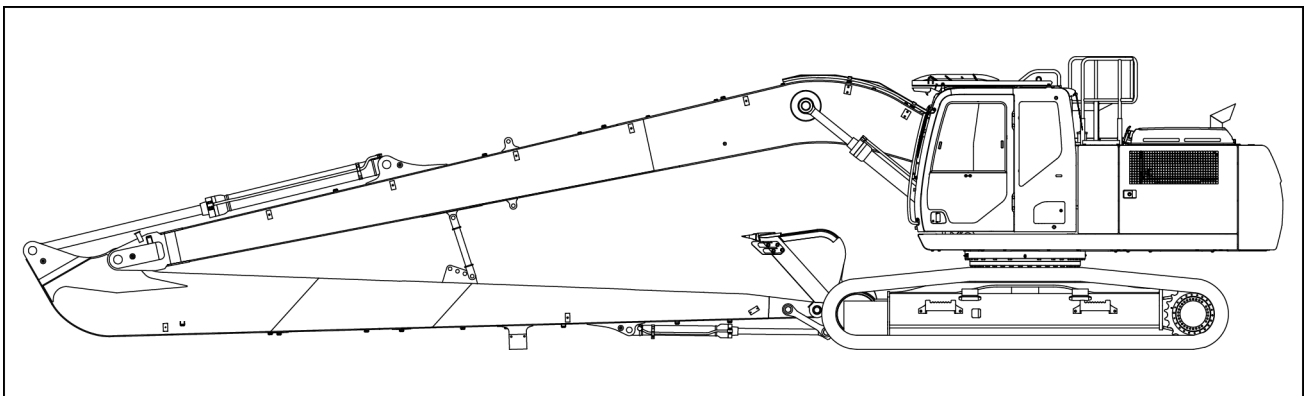

SMIL15CEX5463EA 2

**Long Reach version**

When ordering parts, obtaining information or assistance, always supply your CASE CONSTRUCTION Dealer with the type and serial number of your machine or accessories. Write the following in the spaces below: the type, serial number and year of manufacture of your machine, accessories and the serial numbers of the various hydraulic and mechanical components.

### Machine

(1) Designation/Model  
Hydraulic Excavator CX250D

(2) Product Identification Number (PIN)

(3) Year of Construction

(4) Model Year

(5) Maximum operating mass  
(the weight shown on the manufacturer's plate is the value using the heaviest configuration and that it does not always correspond to the transport configuration)

(6) Engine power ISO 14396

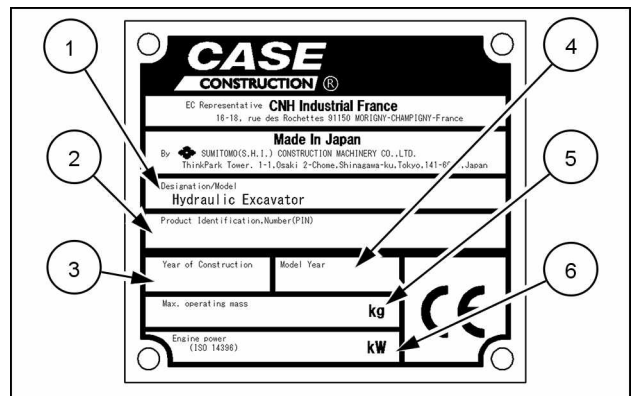

SMIL15CEX3307AA 3



## Engine

Manufacturer and model: ISUZU AQ-4HK1X

Serial number:

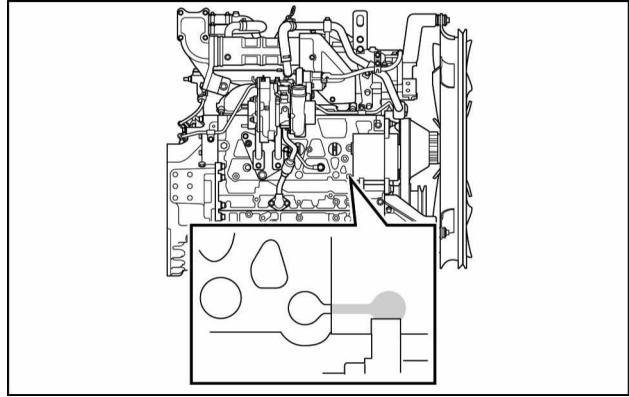

SMIL14CEX1604AA 4

## ID label

This is attached on the cylinder head cover.

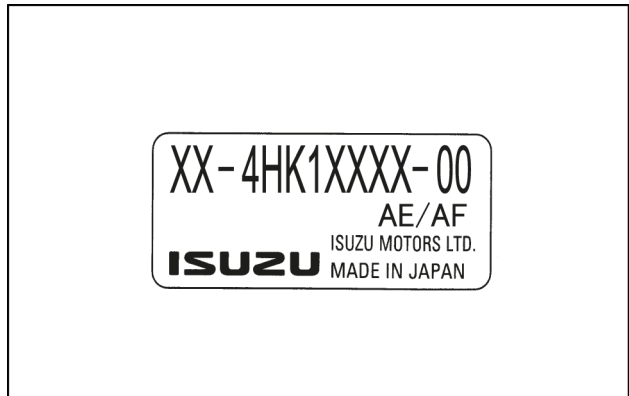

SMIL14CEX1606AA 5

## Emission decal

The emission decal is affixed on the cylinder head cover. It describes important details for using the engine. Make sure to read before using the engine. Also, the emission decal describes details regarding the engine only.

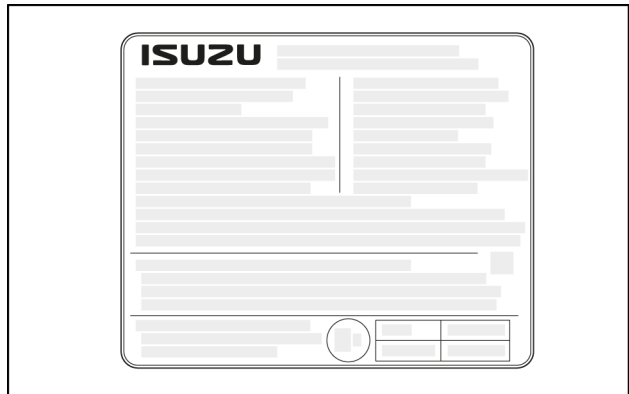

SMIL14CEX1607AA 6

## SCR (Selective Catalytic Reduction) serial number

The number is stamped on top of the urea SCR.

1. Front DOC (Diesel Oxidation Catalyst) serial:
2. Center DOC serial:
3. SCR serial:

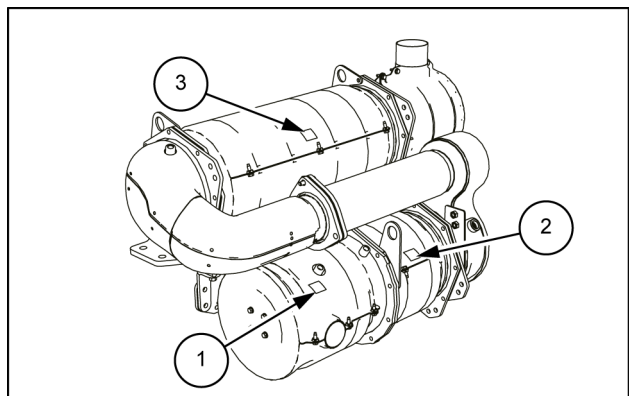

SMIL14CEX1608AB 7

**Structure protection ROPS (Roll Over Protective Structure)**

Complies with ISO 12117-2

Identification number:

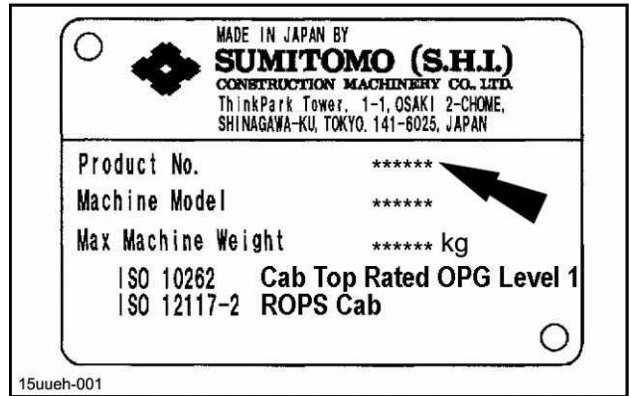

15UUEH-001 8

**Cab protection FOPS (Falling Objects Protective Structure)**

Complies with ISO 10262 level 2.

Product identification number:

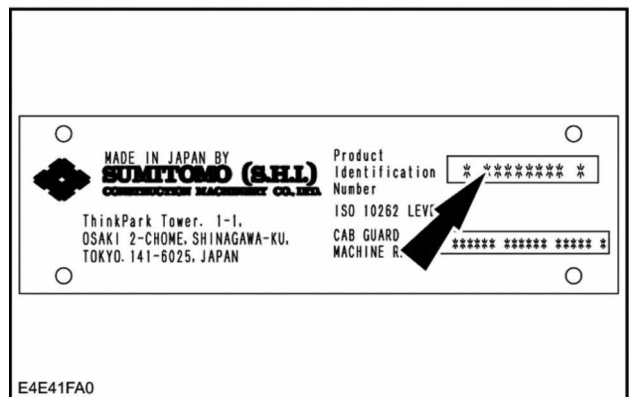

E4E41FA0 9

**Quick coupler (optional)**

- (1) Serial number:
- (2) Weight:
- (3) Working pressure:
- (4) Type/Model:
- (5) Part number:
- (6) Year of manufacture:
- (7) SWL (Safe Working Load):

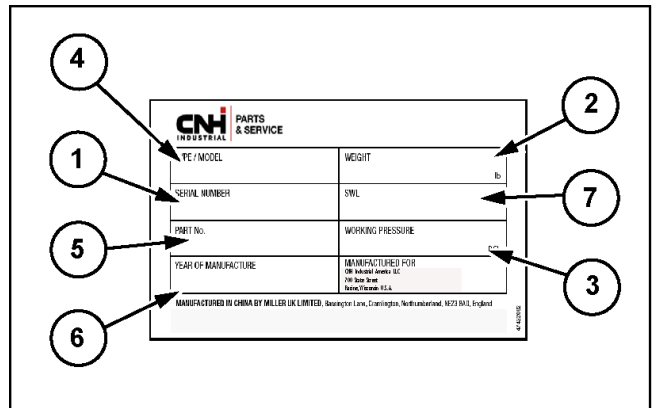

**Component serial numbers**

- Hydraulic pump:
- Swing reduction gear:
- Travel reduction gears:
- Travel control valve:
- Attachment control valve:
- Swing control valve:

## Product identification - Machine orientation

The terms "Right-hand", "Left-hand", "Front" and "Rear" are used in this manual to indicate the sides as they are seen from the operator's seat when the cab is over the idler wheels.

**NOTE:** the illustration shows the machine in normal travel position. In normal travel position, the cab is over the idler wheels. The travel reduction gears are at the rear of the upperstructure. This manual uses the terms "right", "left", "front" and "rear" to show the side viewed from the operator's seat when the cab is located above the idler wheel.

- A. Front
- B. Rear
- C. Right side
- D. Left side
- E. Travel motor
- F. Idler wheel

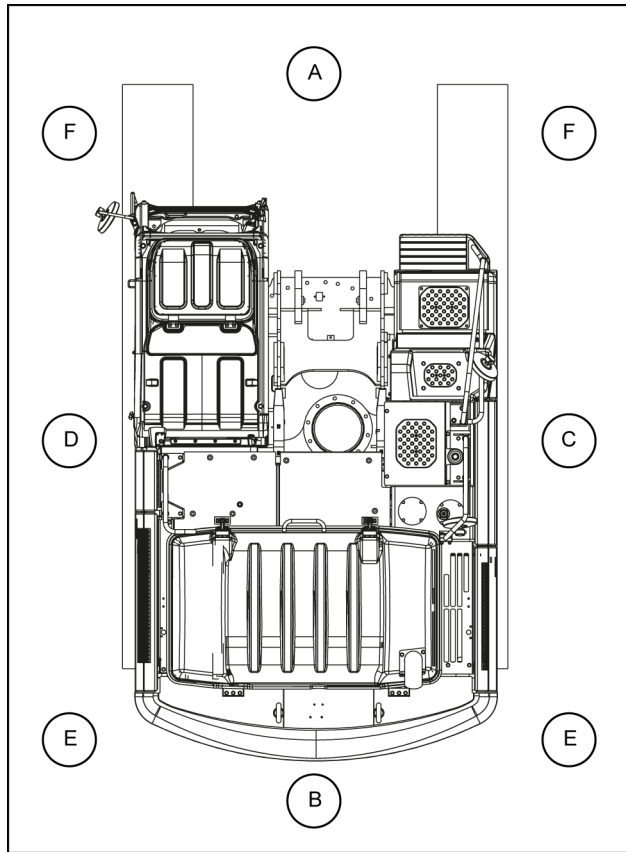

SMIL14CEX1611BB 1



## **SERVICE MANUAL**

### **Engine**

**CX250D Crawler excavators LC version (TIER4 FINAL) - MEA Market**  
**CX250D Long Reach Crawler excavators LC Long Reach (TIER4 FINAL) -**  
**MEA Market**

# Contents

---

## Engine - 10

[10.001] Engine and crankcase .....	10.1
[10.102] Pan and covers .....	10.2
[10.106] Valve drive and gears .....	10.3
[10.101] Cylinder heads .....	10.4
[10.105] Connecting rods and pistons .....	10.5
[10.103] Crankshaft and flywheel.....	10.6
[10.216] Fuel tanks .....	10.7
[10.206] Fuel filters .....	10.8
[10.218] Fuel injection system.....	10.9
[10.202] Air cleaners and lines .....	10.10
[10.250] Turbocharger and lines.....	10.11
[10.254] Intake and exhaust manifolds and muffler .....	10.12
[10.500] Selective Catalytic Reduction (SCR) exhaust treatment.....	10.13
[10.501] Exhaust Gas Recirculation (EGR) - Diesel Particulate Filter (DPF) exhaust treatment .....	10.14
[10.400] Engine cooling system .....	10.15
[10.414] Fan and drive .....	10.16
[10.310] Aftercooler.....	10.17

[10.304] Engine lubrication system ..... 10.18





## **Engine - 10**

### **Engine and crankcase - 001**

**CX250D Crawler excavators LC version (TIER4 FINAL) - MEA Market**  
**CX250D Long Reach Crawler excavators LC Long Reach (TIER4 FINAL) -**  
**MEA Market**



This as a preview PDF file from [best-manuals.com](http://best-manuals.com)



Download full PDF manual at [best-manuals.com](http://best-manuals.com)