

BOMAG

FAYAT GROUP

Service Manual

BW 28 RH



S-538-120

S/N 101 538 42 1001>

Pneumatic tyred roller

Table of contents

1	General	9
	1.1 Introduction	10
	1.2 Concerning your safety	12
	1.2.1 Basic prerequisites.....	12
	1.2.2 Definition of responsible persons.....	15
	1.2.3 Basic safety regulations for safe operation.....	16
	1.2.4 Handling fuels and lubricants.....	18
	1.2.5 Loading / transporting the machine.....	23
	1.2.6 Start-up procedure.....	24
	1.2.7 Driving the machine; working operation.....	25
	1.2.8 Refuelling.....	27
	1.2.9 Emergency procedures.....	28
	1.2.10 Maintenance work.....	29
	1.2.11 Repair.....	31
	1.2.12 Signage.....	31
	1.2.13 Safety Components.....	40
	1.3 Maintenance and repair	42
	1.3.1 Notes on repair.....	42
	1.3.2 Preliminary remarks and safety notes.....	58
	1.3.3 Preparations / concluding work.....	59
	1.3.4 Parking the machine in secured condition.....	60
2	Fuels and lubricants	63
	2.1 Fuels and lubricants	64
	2.1.1 Fuels and lubricants.....	64
	2.2 List of fuels and lubricants	70
3	Technical data	71
	3.1 Technical data	72
	3.1.1 Noise and vibration data.....	74
	3.2 Additional technical data	75
	3.3 Terms and basis of calculation	77
4	Overview of machine	79
	4.1 General	80
	4.2 Electric systems	86
	4.3 Hydraulic system	89
	4.4 Tyre inflation system	91
	4.5 Water spraying system	92
	4.6 Air conditioning	95
5	Electric systems	97
	5.1 Overview of electric system	98
	5.2 CAN bus structure	101
	5.3 Diagnostic possibilities	103
	5.4 Table of fuels and lubricants	104
	5.5 Wiring	113
	5.6 Level sensor in diesel tank (R03)	125

Table of contents

5.7	Electric module, A108	126
5.8	Central electrics	127
5.9	Control console cabin	131
5.10	Fuse assignment	133
5.10.1	Notes on safety.....	133
5.10.2	Central electrics.....	133
5.10.3	Main fuses.....	135
5.10.4	Control console cabin.....	135
5.11	Operator's stand	137
5.11.1	Operating console.....	137
5.11.2	Travel lever console.....	138
5.12	Starting the engine with jump leads	139
5.13	Telemecanique switch	140
5.14	Deutsch plug, series DT and DTM	142
5.15	Inspection and maintenance work	146
5.15.1	Maintenance Table.....	146
5.15.2	Every 500 operating hours.....	146
6	Training of electric system	149
6.1	General information	150
6.1.1	Known faults.....	150
6.1.2	Software versions.....	151
6.2	Notes on commissioning the machine	154
6.2.1	Initial commissioning of the controls.....	154
6.2.2	Checking the set serial number.....	157
6.2.3	Teaching the cross-slope sensor <small>from software version V1.05</small>	158
6.3	Optional equipment	160
6.3.1	Activating/deactivating the AZ14 temperature gauge.....	160
6.3.2	Activating/deactivating the T3 tyre inflation system.....	162
6.3.3	Activating/deactivating the spraying system.....	164
6.3.4	Activating/deactivating the emulsion mixing system.....	166
6.4	Diagnostics system	168
6.4.1	Diagnostics system.....	168
6.4.2	Changing the unit system.....	175
6.5	Fault codes	177
6.5.1	Display fault codes.....	177
6.5.2	BOMAG DTC fault code list.....	181
6.5.3	Deutz DTC fault code list, EMR3.....	203
6.5.4	Deleting stored fault codes.....	270
6.6	Input codes	274
6.6.1	Activate input mode.....	274
6.6.2	Activate service mode.....	276
6.6.3	Driving against the closed brake.....	278
6.6.4	Input code list.....	280
6.7	Special tools	286
6.8	Measures after replacing or repairing components	287
6.8.1	Replacement of the ESX control.....	287

6.8.2	Replacement of engine components.....	287
6.8.3	Replacing components with setup procedure.....	287
6.8.4	Replacing components without an adjustment procedure.....	287
6.8.5	Function test.....	288
7	Diesel engine.....	289
7.1	Overview of diesel engine.....	290
7.2	Lubrication oil circuit.....	294
7.3	Cooling circuit.....	296
7.4	Fuel system.....	298
7.5	Common Rail.....	300
7.6	Exhaust gas recirculation.....	306
7.7	Wastegate charge pressure controller.....	307
7.8	Engine electrics.....	308
7.8.1	Diagnostics interface, X32.....	308
7.8.2	CAN bus structure.....	309
7.8.3	EMR3 system overview.....	310
7.8.4	Pin assignment of engine control.....	319
7.8.5	Rotary speed sensor for camshaft, B114.....	324
7.8.6	Crankshaft speed sensor, B130.....	325
7.8.7	Rail pressure sensor, B93.....	327
7.8.8	Fuel pressure sensor, B145.....	329
7.8.9	Fuel Control Unit Y137.....	331
7.8.10	Injectors, Y147, Y149, Y169 and Y170.....	331
7.8.11	Oil pressure sensor, B88.....	332
7.8.12	Charge air temperature/charge pressure sensor, B133.....	333
7.8.13	EMR-coolant - temperature sensor, B113.....	335
7.8.14	Glow plugs, R81 to R84.....	338
7.8.15	Fuel pre-heating.....	339
7.8.16	Sensor, water in fuel, B124.....	340
7.8.17	Air filter vacuum switch, B03.....	340
7.8.18	Float switch coolant tank, B55.....	341
7.8.19	Removing and installing the electric starter.....	341
7.9	Inspection and maintenance work.....	343
7.9.1	Maintenance Table.....	343
7.9.2	Checks prior to start up.....	344
7.9.3	Every 250 operating hours.....	345
7.9.4	Every 500 operating hours.....	347
7.9.5	Every 1000 operating hours.....	352
7.9.6	Every 2000 operating hours.....	352
7.9.7	Every 3000 operating hours.....	356
7.9.8	As required.....	357
8	Hydraulic system.....	363
8.1	Overview of hydraulics.....	364
8.2	Open and closed hydraulic circuit.....	367
8.3	Hydraulic units.....	369
8.3.1	Travel pump.....	369

Table of contents

8.3.2	Swash plate principle, pump.....	376
8.3.3	Travel motor.....	377
8.3.4	Swash plate principle, motor.....	381
8.3.5	External gear pumps.....	382
8.3.6	Outer gear motors non-reversible.....	384
8.3.7	Steering valve.....	385
8.3.8	Diaphragm type pressure accumulator.....	386
8.4	Charge circuit.....	389
8.5	Travel circuit.....	391
8.5.1	Brake circuit.....	398
8.6	Steering circuit.....	404
8.7	Inspection and maintenance work on travel gear.....	408
8.7.1	Maintenance Table.....	408
8.7.2	Every 250 operating hours.....	409
8.7.3	Every 2000 operating hours.....	410
8.8	Inspection and maintenance work on hydraulic system.....	412
8.8.1	Maintenance Table.....	412
8.8.2	Checks prior to start up.....	412
8.8.3	Every 500 operating hours.....	413
8.8.4	Every 1000 operating hours.....	415
8.8.5	Every 2000 operating hours.....	417
9	Wheels and tyres.....	421
9.1	Rubber tyres.....	422
9.2	Tyre compaction values.....	423
9.2.1	Tyre compaction values [metric].....	423
9.2.2	Tyre compaction values [imperial].....	424
9.3	Tyre inflation system.....	425
9.3.1	Overview of tyre inflation system.....	425
9.3.2	Tyre inflation system.....	426
9.4	Inspection and maintenance work.....	431
9.4.1	Maintenance Table.....	431
9.4.2	Checks prior to start up.....	431
9.4.3	Every 250 operating hours.....	434
9.4.4	Every 500 operating hours.....	435
9.4.5	Every 1000 operating hours.....	436
10	Water spraying system.....	437
10.1	Overview of water spraying system.....	438
10.2	Inspection and maintenance work.....	441
10.2.1	Maintenance Table.....	441
10.2.2	Checks prior to start up.....	441
10.2.3	As required.....	445
11	Ballasting of machine.....	453
11.1	Ballasting the machine.....	455
11.1.1	Ballasting the machine with loose ballast.....	456
11.1.2	Ballasting the machine with water.....	457
11.1.3	Removing and installing concrete slabs.....	458

11.1.4	Removing and installing underfloor weights.....	460
12	Front axle.....	465
12.1	Repair overview for front axle.....	467
12.2	Disassembling the front axle.....	468
12.3	Assembling the front axle.....	476
12.4	Inspection and maintenance work.....	502
12.4.1	Maintenance Table.....	502
12.4.2	Every 500 operating hours.....	502
13	Troubleshooting.....	503
13.1	Preliminary remarks.....	504
13.2	Emergency procedures.....	505
13.2.1	Actuating the emergency stop switch.....	505
13.2.2	Disconnecting the battery.....	505
13.2.3	Towing the machine.....	506
13.3	Troubleshooting, electrical systems.....	509
13.3.1	Preliminary remarks.....	509
13.3.2	Starting the engine with jump leads.....	512
13.3.3	Servicing the battery, checking the main battery isolation.....	513
13.3.4	Fuse assignment.....	514
13.3.5	Fault code display.....	517
13.3.6	Fault codes.....	517
13.3.7	Understanding electric circuit diagrams.....	517
13.3.8	Measuring method.....	531
13.4	Trouble shooting, diesel engine.....	536
13.4.1	Starting the engine with jump leads.....	536
13.4.2	Engine faults.....	537
13.4.3	Fault codes.....	539
13.5	Trouble shooting, hydraulics.....	540
13.5.1	Insufficient hydraulic power.....	540
13.5.2	Trouble shooting axial piston pumps.....	543
13.5.3	Trouble shooting axial piston motors.....	545
13.5.4	Fault table hydraulic components.....	547
13.6	Troubleshooting, emulsion mixing system.....	555
13.6.1	Purging the emulsion mixing system.....	555
13.7	Trouble shooting, air conditioning system.....	556
13.7.1	Trouble shooting in refrigerant circuit, basic principles.....	556
13.7.2	Trouble shooting procedure.....	562
13.7.3	Leak test.....	571
13.7.4	Checking the magnetic clutch	572
14	Special tools.....	575
14.1	Special tools, electrics.....	576
14.2	Special tools, tests and adjustments.....	579
14.3	List of special tools.....	581
15	Disposal.....	583
15.1	Final shut-down of machine.....	584

Table of contents

16	Index	585
	Appendix	601
	A Circuit diagrams.....	603
	A.1 Water spraying diagram 538 311 12.....	603
	A.2 Hydraulic diagram 439.....	605
	A.3 Circuit diagram 423.....	618

1.1 Introduction

General

This manual:

- addresses the BOMAG Customer Service and professionally trained personnel.
- provides support for repair work or maintenance procedures on the machine.

This manual describes the deinstallation, dismantling, assembly, installation as well as the repair of components and assembly groups as far as this makes sense with respect to tools and spare parts supply.

Index

The index is a reference register that will help you to find information in this Service Manual. The index lists keywords in alphabetical order. Cross references (keywords related to page numbers) enable quick and convenient search/navigation.

Keywords concerning the following subjects are listed in the index:

- Electrical operating means
- Plug designations
- Overviews
- Fault codes
- Troubleshooting
- ...

Documentation

For the BOMAG machines described in this manual the following documentation is additionally available:

- Operating and maintenance instructions
- Spare parts catalogue
- Service information (if necessary)

Maintenance/parts service

- Specialist teams are available for you in Germany, Europe and overseas. This tight network ensures close customer contact all over the world.
- Parts for maintenance, service and repair are available from our branch offices and dealers at very short notice.
- BOMAG guarantees long-term availability of all common parts.
- Well-designed catalogues provide an easy guide to finding and ordering the required parts.
- Only use genuine BOMAG parts. These have been specially adapted to the corresponding machine. In this way, you will prevent any problems arising and unnecessary downtimes of your machine.

Updating service

This manual is not subject of an updating service. For this reason we would like to draw your attention to the additionally published service informations.

In case of a new release all necessary changes will be included.

In the course of technical development we reserve the right for technical modifications without prior notification.

Copyright

Information and illustrations in this manual must not be reproduced and distributed, nor must they be used for the purpose of competition without the consent of BOMAG. All rights according to the copyright law remain expressly reserved.

1.2 Concerning your safety

1.2.1 Basic prerequisites

1.2.1.1 General

This BOMAG machine has been built in compliance with the latest technical standard and complies with the applicable regulations and technical rules.

However, dangers for persons and property may arise from this machine, if:

- it is used for purposes other than the ones it is intended for,
- it is operated by untrained personnel,
- it is changed or converted in an unprofessional way,
- the safety instructions are not observed.

Each person involved in the operation, maintenance and repair of the machine must therefore read and comply with these safety regulations. If necessary, the operating company must obtain the relevant signatures as confirmation.

Furthermore, the following obviously also applies:

- applicable accident prevention instructions,
- generally accepted safety and road traffic regulations,
- country specific safety regulations.

It is the duty of the operator to be acquainted with the safety regulations and to apply these accordingly. This also applies for local regulations and regulations concerning different types of handling activities. Should the recommendations in these instructions be different from the regulations valid in your country, you must comply with the safety regulations valid in your country.

1.2.1.2 Explanation of signal words used:



DANGER!

Danger to life if failing to comply!

Sections marked accordingly indicate an extremely dangerous situation that could lead to fatal or severe injuries, if this warning is disregarded.



WARNING!

Danger to life or danger of severe injuries if failing to comply!

Sections marked accordingly indicate a dangerous situation that could lead to fatal or severe injuries, if this warning is disregarded.



CAUTION!

Danger of injury if failing to comply!

Sections marked accordingly indicate a dangerous situation that could lead to fatal or severe injuries, if this warning is disregarded.



NOTICE!

Danger of material damage if failing to comply!

Sections marked accordingly indicate possible dangers for machines or components.



Sections marked accordingly indicate technical information or notes on using the machine or its components.





ENVIRONMENT!

Environmental damage if failing to comply!





Paragraphs marked accordingly indicate practices for safe and environment-friendly disposal of fuels and lubricants as well as replacement parts.

1.2.1.3 Personal protective equipment

Depending on the work to be carried out, personal protective equipment is required (to be provided by the operating company):

	Working clothes	Tight fitting working clothes with low tear resistance, tight sleeves and without any projecting parts protect against being caught by moving components.
	Safety shoes	To protect against heavy falling parts and slipping on slippery ground.
	Protective gloves	To protect the hands against excoriation, punctures or deep injuries, against irritating and caustic substances as well as against burns.

General – Concerning your safety

	Safety goggles	To protect the eyes against airborne particles and squirting fluids.
	Face protection	To protect the face against airborne particles and squirting fluids.
	Hard hat	To protect the head against falling parts and to protect against injuries.
	Hearing protection	To protect hearing against excessive noise.
	Respiratory protection	To protect respiratory tracts against substances or particles.

1.2.1.4 Intended use

This machine must only be used for:

- Compaction of bituminous material, e.g. road surface layers.
- Surface treatment and sealing of top layers, e.g. road surface layers.
- Light compaction work in earth construction and road bases.

Intended use also includes compliance with the specified operating, maintenance and repair measures.

1.2.1.5 Improper use

Dangers may arise from the machine when it is used for purposes other than the one it is intended for.

Any danger caused by improper use is the sole responsibility of the operating company or driver/operator, the manufacturer cannot be made liable.

Examples for improper use are:

- Fast downhill travel in a high travel range
- Overloading the machine with ballast
- Inappropriate emptying of the ballast tanks
- Driving on subsoils with too low load bearing capacity
- Driving on slippery subsoils (e.g. ice and snow)
- Driving on surfaces of insufficient size (danger of turning over)
- Unauthorized use of public roads
- Using the machine for towing

Transporting persons, except the machine driver, is prohibited.

Starting and operating the machine in explosive environments and in underground mining is prohibited.

1.2.2 Definition of responsible persons

1.2.2.1 Operating company

The operating company is the natural or juridical person who uses the machine or in who's name the machine is used.

The operating company must make sure that the machine is only used for the purpose it is intended for and in strict compliance with the safety regulations mentioned in these operating and maintenance instructions.

The operating company must determine and assess the danger in its company. It must then take appropriate action to ensure health and safety at work for its employees and point out any remaining dangers.

The operating company must determine whether there are special operational hazards such as a toxic atmosphere or limiting soil conditions. Such conditions require special, additional measures to remove or reduce the hazard.

The operating company must make sure that all users read and understand the information concerning safety.

The operating company is responsible for the planning and professional execution of regular safety inspections.

1.2.2.2 Expert / qualified person

An expert / qualified person is a person who, based on his/her professional education and experience, has profound knowledge in the field of construction equipment and the machine in question in particular.

This person is acquainted with the applicable governmental industrial safety regulations, accident prevention instructions, guidelines and generally acknowledged technical rules and regulations (standards, directives, technical rules of other member states of the European Union or other contractual states concerning the agreement about the European Economic Area) in as far as is necessary to be able to judge the safe condition of this machine.

General – Concerning your safety

1.2.2.3 Driver / operator

This machine must only be operated by trained, instructed persons entrusted by the operating company aged 18 or more.

Observe your local laws and regulations.

Rights, obligations and rules of conduct for driver or operator:

The driver or operator must:

- be instructed about his rights and obligations,
- wear protective equipment as appropriate for the application,
- have read and understood the operating instructions,
- have made himself familiar with the operation of the machine,
- be physically and psychologically able to drive and operate the machine.

Persons under the influence of alcohol, medication or drugs are not allowed to operate, service or repair the machine.

Maintenance and repair work requires specific knowledge and must therefore only be performed by trained specialists.

1.2.3 Basic safety regulations for safe operation

1.2.3.1 Remaining dangers, remaining risks

Despite careful work and compliance with standards and regulations it cannot be ruled out that further dangers may arise when working with and handling the machine.

Both the machine as well as all other system components comply with the currently valid safety regulations. Nevertheless, remaining risks cannot be ruled out completely, even when using the machine for the purpose it is intended for and following all information given in the operating instructions.

A remaining risk can also not be excluded beyond the actual danger zone of the machine. Persons remaining in this area must pay particular attention to the machine, so that they can react immediately in case of a possible malfunction, an incident or failure etc.

All persons remaining in the area of the machine must be informed about the dangers that arise from the operation of the machine.

1.2.3.2 Regular safety inspections

Have the machine inspected by an expert / qualified person as required for the conditions the machine is working under, but at least once every year.

1.2.3.3 Modifications and alterations to the machine

Unauthorized changes to the machine are prohibited for safety reasons.

Original parts and accessories have been specially designed for this machine.

We wish to make explicitly clear that we have not tested or approved any parts or accessories not supplied by us.

The installation and/or use of such products may have an adverse effect on the active and/or passive safety.

When making conversions or changes approved by the manufacturer you must strictly adhere to the maximum weight of the machine.

This applies especially when weight relevant options are retrofitted (e.g. cabin, thermal aprons).

If the maximum weight is exceeded, remove ballast from the ballast compartment.

1.2.3.4 Damage, defects, misuse of safety devices

Machines which are not safe to operate or in traffic must be immediately taken out of service and shall not be used, until these deficiencies have been properly rectified.

Safety installations and switches must neither be removed nor must they be made ineffective.

1.2.3.5 Roll Over Protective Structure (ROPS)



On machines with cab the ROPS is an integral part of the cab.

The frame of the machine must not be warped, bent or cracked in the area of the ROPS fastening.

The ROPS must not show any rust, damage, hairline cracks or open fractures.

The real machine weight must never exceed the testing weight for the ROPS.

No accessories may be welded or bolted on and no additional holes must be drilled without the consent of the manufacturer, since this will impair the strength of the unit.

The ROPS must therefore also not be straightened or repaired if it is damaged.

A defect ROPS must generally be replaced with an original spare part in close coordination with the manufacturer.

1.2.4 Handling fuels and lubricants

1.2.4.1 Preliminary remarks

The operating company must ensure that all professional users have read and follow the corresponding safety data sheets for the individual fuels and lubricants.

Safety data sheets provide valuable information about the following characteristics:

- name of substance
- possible dangers
- composition / information on constituents
- first-aid measures
- fire fighting measures
- measures in case of accidental release
- handling and storage
- limitation and monitoring of exposure / personal protective equipment
- physical and chemical properties
- stability and reactivity
- toxicological data
- environmental data
- notes on waste disposal
- information on transport
- legislation
- other data

1.2.4.2 Safety regulations and environmental protection regulations for handling diesel fuel

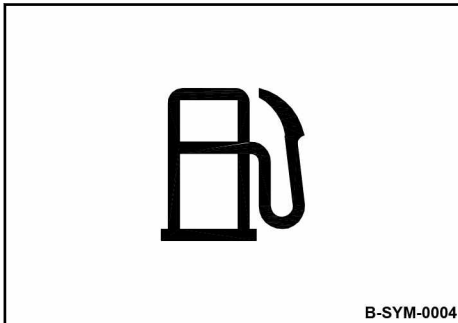

Fig. 1



WARNING!

Danger of burning by ignited diesel fuel!

- Do not allow diesel fuel to come into contact with hot components.
- Smoking and open fire is prohibited!
- Wear your personal protective equipment (protective gloves, protective clothing).



CAUTION!

Health hazard caused by contact with diesel fuel!

- Wear your personal protective equipment (protective gloves, protective clothing).
- Do not inhale any fuel fumes.
- Avoid contact.



CAUTION!

Danger of slipping on spilled diesel fuel!

- Immediately bind spilled diesel fuel with an oil-binding agent.



ENVIRONMENT!

Diesel fuel is an environmentally hazardous substance!

- Always keep diesel fuel in proper containers.
- Immediately bind spilled diesel fuel with an oil-binding agent and dispose of properly.
- Dispose of diesel fuel and fuel filters according to regulations.

General – Concerning your safety

1.2.4.3 Safety regulations and environmental protection regulations for handling AdBlue®/DEF

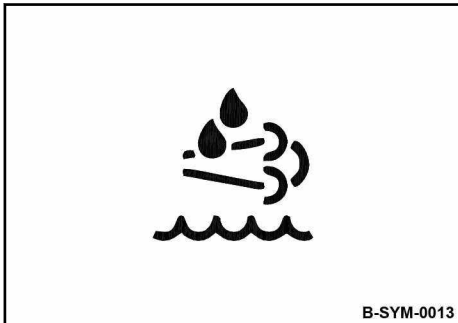

Fig. 2



CAUTION!

Health hazard caused by ammonia vapours!

- Wear your personal protective equipment (protective gloves, protective clothing).
- Do not inhale ammonia vapours.
- Avoid contact and consumption.



AdBlue®/DEF has not been classified as environmentally harmful.

1.2.4.4 Safety regulations and environmental protection regulations for handling oil

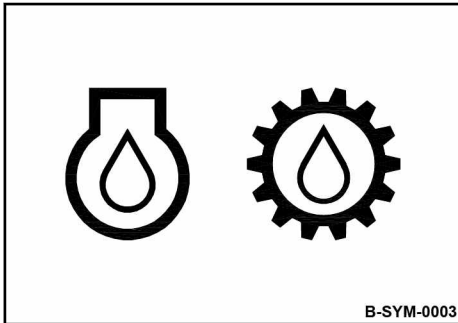

Fig. 3



WARNING!

Danger of burning by ignited oil!

- Do not allow oil to come into contact with hot components.
- Smoking and open fire is prohibited!
- Wear your personal protective equipment (protective gloves, protective clothing).



CAUTION!

Health hazard caused by contact with oil!

- Wear your personal protective equipment (protective gloves, protective clothing).
- Do not inhale any oil vapours.
- Avoid contact.



CAUTION!

Danger of slipping on spilled oil!

- Immediately bind spilled oil with an oil-binding agent.



ENVIRONMENT!

Oil is an environmentally hazardous substance!

- Always keep oil in proper containers.
- Immediately bind spilled oil with an oil-binding agent.
- Dispose of oil and oil filter according to regulations.

1.2.4.5 Safety regulations and environmental protection regulations for handling hydraulic oil

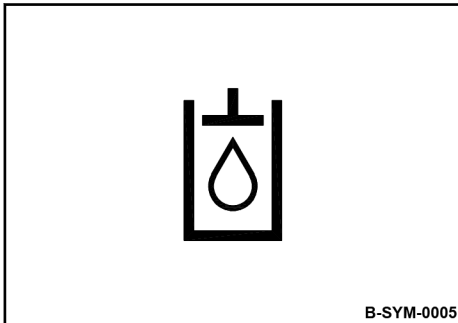

Fig. 4



WARNING!

Danger of injury caused by escaping pressure fluid!

- Always depressurize the hydraulic system before starting work in the hydraulic system.
- Wear your personal protective equipment (protective gloves, protective clothing, goggles).



Should pressure fluid penetrate the skin, immediate medical help is required.



WARNING!

Danger of burning by ignited hydraulic oil!

- Do not allow hydraulic oil to come into contact with hot components.
- Smoking and open fire is prohibited!
- Wear your personal protective equipment (protective gloves, protective clothing).



CAUTION!

Health hazard caused by contact with hydraulic oil!

- Wear your personal protective equipment (protective gloves, protective clothing).
- Do not inhale any oil vapours.
- Avoid contact.



CAUTION!

Danger of slipping on spilled oil!

- Immediately bind spilled oil with an oil-binding agent.



ENVIRONMENT!

Oil is an environmentally hazardous substance!

- Always keep oil in proper containers.
- Immediately bind spilled oil with an oil-binding agent.
- Dispose of oil and oil filter according to regulations.

1.2.4.6 Safety regulations and environmental protection regulations for handling coolants

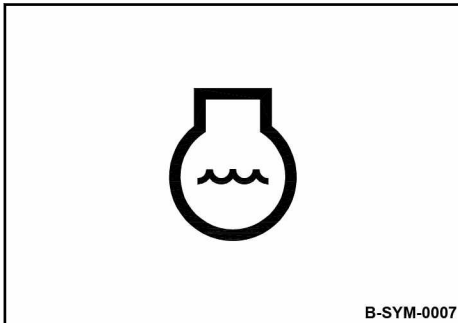

Fig. 5



WARNING!

Danger of scalding by hot fluid!

- Open the compensation tank only when the engine is cold.
- Wear your personal protective equipment (protective gloves, protective clothing, goggles).



CAUTION!

Health hazard caused by contact with coolant and coolant additives!

- Wear your personal protective equipment (protective gloves, protective clothing).
- Do not inhale any fumes.
- Avoid contact.



CAUTION!

Danger of slipping on spilled coolant!

- Immediately bind spilled coolant with an oil-binding agent.



ENVIRONMENT!

Coolant is an environmentally hazardous substance!

- Always keep coolant and coolant additives in proper containers.
- Immediately bind spilled coolant with an oil-binding agent and dispose of it according to regulations.
- Dispose of coolant according to regulations.

1.2.4.7 Safety regulations and environmental protection regulations for handling battery acid

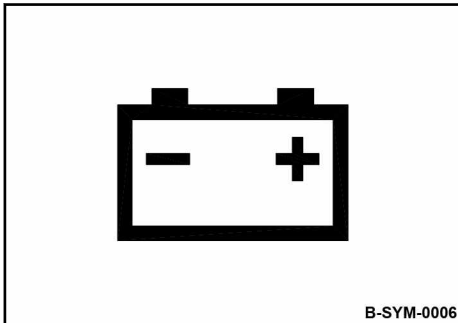

Fig. 6:



WARNING!

Danger of cauterization with acid!

- Wear your personal protective equipment (protective gloves, protective clothing, goggles).
- Do not allow clothes, skin or eyes to come into contact with acid.
- Rinse off spilled battery acid immediately with lots of water.



Rinse acid off clothes, skin or eyes immediately with lots of clean water.

Immediately call for medical advice in case of cauterization.



WARNING!

Danger of injury caused by exploding gas mixture!

- Remove the plugs before starting to recharge the battery.
- Ensure adequate ventilation.
- Smoking and open fire is prohibited!
- Do not lay any tools or other metal objects on the battery.
- Do not wear jewellery (watch, bracelets, etc.) when working on the battery.
- Wear your personal protective equipment (protective gloves, protective clothing, goggles).



ENVIRONMENT!

Battery acid is an environmentally hazardous substance!

- Dispose of battery and battery acid according to regulations.

1.2.5 Loading / transporting the machine

Use only stable loading ramps of sufficient load bearing capacity.

Loading ramps and transport vehicle must be free of grease, oil, snow and ice.

The ramp inclination must be less than the gradeability of the machine.

Make sure that persons are not endangered by the machine tipping or sliding off. The instructing person must stand within the view of the operator, but outside the danger area.

Do not use damaged or in any other way impaired lifting points.

Always use appropriate lifting and lashing tackle on the lifting and lashing points.

Use lifting tackle only in the prescribed direction of load application.

Lifting tackle must not be damaged by machine components.

Secure the machine on the transport vehicle against rolling, slipping and turning over.

Loads must only be attached and hoisted by an expert / qualified person.

Use only lifting and lashing tackle with sufficient load bearing capacity for the weight to be loaded.

Fasten the lifting gear only at the specified lifting points.

Danger to the life of persons if they step or stand under a suspended load.

When lifting the machine, avoid uncontrolled movements of the load. If necessary, hold the load with guide ropes.

1.2.6 Start-up procedure

1.2.6.1 Prior to starting up

Use only machines which are serviced at regular intervals.

Become acquainted with the equipment, the indicators and control elements, the working principle of the machine and the working area.

Use your personal protective equipment (hard hat, safety boots, if necessary also goggles and ear protection).

Do not take any loose objects with you or fasten them to the machine.

Before mounting the machine check whether:

- persons or obstructions are beside or under the machine,
- the machine is free of oily and combustible materials,
- all access steps, grips and platforms are free of obstacles, grease, oils, fuel, dirt, snow and ice,
- all safety elements are in place,
- all maintenance flaps and doors are closed and locked.

Use only the intended access steps and grips to mount the machine.

Before start up, carry out all required visual inspections and function tests.

If the following tests reveal damages or other faults, the machine must not be operated, until these deficiencies have been corrected.

Do not operate the machine with defective indicators and control elements.

1.2.6.2 Starting the engine

The machine must only be started and operated from the driver's seat.

Before starting and moving the machine, make sure that there is nobody in the danger zone.

To start, set all control levers to "neutral position".

Do not use any starting aids like start pilot or ether.

The machine must not be operated with damaged, missing or non-functional safety installations.

After starting check all display instruments.

Do not inhale exhaust fumes, because they contain toxic substances, which could cause damage to health, unconsciousness or even death.

For operation in closed or partly closed rooms ensure adequate ventilation.

1.2.6.3 Starting the engine with jump leads

Connect positive with positive and negative with negative (ground cable) – always connect the ground strap last and disconnect it first! A wrong connection will cause severe damage in the electric system.

Do not start the engine by shorting the electric terminals on the starter motor, because the machine may start to drive immediately.

1.2.7 Driving the machine; working operation

1.2.7.1 Persons in the danger area

Before taking up work, also after breaks, you should always convince yourself that the danger zone is free of persons or obstructions, especially when driving in reverse.

Give warning signals, if necessary. Stop work immediately if persons remain in the danger zone, despite the warning.

Do not step or stand in the steering range of the front wheels while the engine is running.

1.2.7.2 Driving the machine

Always wear the seat belt when driving.

Do not drive on bases with insufficient load bearing capacity.

General – Concerning your safety

Do not drive on ice and snow.

If the machine has contacted high-voltage power lines:

- do not leave the operator's stand,
- warn others from coming close to or touching the machine,
- if possible drive the machine out of the danger zone,
- have the power switched off.

Operate the machine only from the operator's platform.

Keep the cabin doors closed.

Do not adjust the driver's seat while driving.

Do not climb onto or off the machine while the machine is driving.

Do not use the machine to transport persons.

In case of unusual noises and development of smoke perform trouble shooting and have the fault corrected.

Match the speed to the working conditions.

Do not make extreme steering movements when driving with high speed, danger of tipping over!

Always give way to loaded transport vehicles.

Switch the lights on if the visibility is poor.

Always keep a safe distance to excavation pit borders, embankments and edges.

Refrain from any work that could adversely affect the stability of the machine.

Always keep a sufficient distance when passing through subways, under bridges, tunnels, electric power lines etc.

1.2.7.3 Driving up and down slopes

Do not drive on gradients or slopes exceeding the maximum gradeability of the machine ↪ *Chapter 3 „Technical data“ on page 71.*

Drive extremely carefully on gradients and always directly up or down the slope.

Soil conditions and weather influences impair the gradeability of the machine.

Wet and loose soil considerably reduces traction of the machine on inclinations and slopes. Increased danger of accident!

1.2.7.4 Cross slope

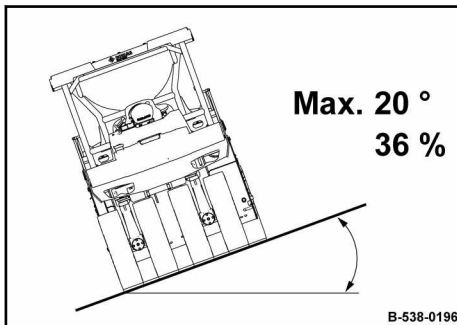

Fig. 7

The tipping angle was measured statically on level, hard ground with the machine stopped and without steering.

The max. permissible cross slope of the machine may be limited by the max. permissible slanted position of the engine.

The specified angle must not be exceeded.

With loose soil, acceleration/deceleration, steering operated or attached accessories, the tipping angle may be considerably lower.

Driving across slopes should therefore be strictly avoided, because of the high risk of tipping over and the related risk of severe or even fatal accidents.

1.2.7.5 Parking the machine

Park the machine on horizontal, level, firm ground.

Before leaving the machine:

- shift all control levers to “Neutral position”, “Off” or “0”,
- apply the parking brake,
- shut down the engine, pull off the ignition key,
- pull off the main battery switch,
- secure the machine against unauthorized use.

Do not jump off the machine, but use hand grips and access steps.

Mark machines, which could be in the way, with a clearly visible sign.

When parking on ascents or descents use appropriate means to secure the machine against rolling.

1.2.8 Refuelling

Do not inhale any fuel fumes.

Refuel only with the engine shut down.

Do not refuel in closed rooms.

No open fire, do not smoke.

Static charges may be generated in the fuel as it passes through the filling system. The discharge of these charges in the presence of combustible vapours can cause fire or an explosion.

Ultra-low sulphur diesel fuel poses a higher risk of combustion caused by the static charging than diesel fuel with a higher sulphur content.

You should therefore always make sure that the filling system is properly grounded and that there is equipotential bonding to the machine. If necessary use a connecting cable between filling system and vehicle ground.

Monitor the entire refuelling process.

Do not spill any fuel. Collect leaking fuel, do not let it seep into the ground.

Wipe off spilled fuel. Keep dirt and water away from the fuel.

A leaking fuel tank can cause an explosion. Ensure tight fit of the fuel tank cover, if necessary replace immediately.

1.2.9 Emergency procedures

1.2.9.1 Actuating the emergency stop switch

In events of emergency and in case of danger actuate the emergency stop switch immediately.

The machine is braked immediately, the engine is shut down.

Restart the machine only after the danger that caused the actuation of the emergency stop switch has been eliminated.

In case of frequent use the wear on the multi-discs brakes will be very high, you should therefore never use the emergency stop switch as a service brake.

1.2.9.2 Disconnecting the battery

In events of emergency, e.g. in case of a cable fire, disconnect the battery from the vehicle network.

Pull out the main battery switch or lift off the battery pole to do so.

1.2.9.3 Towing the machine

Tow the machine only in case of emergency or to avoid an accident.

Before releasing the parking brake apply suitable measures to secure the machine against unintended rolling.

Use a tractor vehicle with sufficient traction and braking power for the unbraked towed load.

You should generally use a tow bar.

Before starting towing operations make sure that the fastening means are able to withstand the load and are fastened at the points provided for this purpose.

Before removing the towing facility apply appropriate measures to secure the machine against unintended rolling.

1.2.10 Maintenance work

1.2.10.1 Preliminary remarks

Adhere to the specified operating, maintenance and repair measures.

The machine must only be serviced by qualified personnel authorised by the operating company.

Keep unauthorised persons away from the machine.

Perform maintenance work only with the engine shut down.

Make sure that the engine cannot be accidentally started during maintenance work.

1.2.10.2 Work on hydraulic lines

Relieve hydraulic pressures before working on hydraulic lines. Hydraulic oil escaping under pressure can penetrate the skin and cause severe injury. Immediately call for medical advice when injured by hydraulic oil.

Do not step in front of or behind the machine when performing adjustment work in the hydraulic system.

Do not change the setting of pressure relief valves.

Drain the hydraulic oil at operating temperature – danger of scalding!

Any hydraulic oil must be collected and disposed of in an environmentally friendly way.

Always collect and dispose of hydraulic oils separately.

Do not start the engine after draining the hydraulic oil. Once all work is completed (with the system still depressurized!) check all connections and fittings for leaks.

Hydraulic hoses must be visually inspected at regular intervals.

Do not mix up hoses by mistake.

Only genuine BOMAG replacement hydraulic hoses ensure that the correct hose type (pressure range) is used at the right location.

1.2.10.3 Working on the engine

Do not work on the fuel system while the engine is running - danger to life due to high pressures!

Wait until the engine has stopped, then wait approx. another 15 minutes.

Keep out of the danger zone during the initial test run.

In case of leaks return to the workshop immediately.

Drain the engine oil at operating temperature – danger of scalding!

Wipe off spilled oil, collect leaking oil and dispose of it in an environmentally friendly way.

Store used filters and other oil contaminated materials in a separate, specially marked container and dispose of them in an environmentally friendly way.

The settings for idle speed and highest speed must not be changed, since this would affect the exhaust gas values and cause damage to engine and power train.

Engine and exhaust system work at high temperatures. Keep combustible materials away and do not touch any hot surfaces.

Check and change coolant only when the engine is cold. Collect coolant and dispose of it in an environmentally friendly way.

1.2.10.4 Maintenance work on electric components and battery

Before starting to work on electric parts of the machine disconnect the battery and cover it with insulating material.

Do not use fuses with higher ampere ratings and do not bridge fuses.

When working on the battery, smoking or open fire is prohibited!

Do not lay any tools or other metal objects on the battery.

Do not wear jewellery (watch, bracelets, etc.) when working on the battery.

The connection cables of the battery must not touch or rub against machine parts.

1.2.10.5 Working on the air conditioning

Faults on the air conditioning should only be remedied by authorized service personnel.

Do not perform welding work in the vicinity of the air conditioning. Danger of explosion!

Do not release refrigerant into the atmosphere, but dispose of it in line with environmental regulations.

1.2.10.6 Working on wheels and tyres

Explosion-like bursting of tyres or parts of tyres and rims can cause most severe or even fatal injuries.

Do not drive with damaged wheels or tyres.

Install the tyres only if you are sufficiently experienced and with the right tools at hand. If necessary have the tyres assembled in a qualified workshop.

Always ensure the correct tyre pressure and do not exceed the specified maximum pressure.

When checking the tyre pressure stand in the extended path of the tyre track. Use an at least 6 meter air hose, so that you can keep a safe distance to the tyre.

Always consider the heavy weight of a wheel during disassembly and assembly. Use a crane or forklift truck equipped with suitable claws or a belt-type hoisting device.

1.2.10.7 Cleaning work

Do not perform cleaning work while the motor is running.

Allow the engine to cool down before starting cleaning work on engine and exhaust system.

Never use gasoline or other easily inflammable substances for cleaning.

When cleaning with a high pressure cleaner, do not subject electrical parts and insulation material to the direct jet of water, or cover them beforehand.

Do not guide the water jet into the exhaust pipe and into the air filter.

1.2.10.8 After maintenance work

Reassemble all guards and protective devices.

Close all maintenance flaps and maintenance doors again.

1.2.11 Repair

Identify a defective machine with a warning sign.

Only operate the machine after it has been repaired.

Repairs must only be performed by an expert/qualified person.

When replacing safety relevant components, only original spare parts must be used.

1.2.12 Signage

Keep stickers and signage in good and legible condition and comply with their meaning.

Replace damaged and illegible stickers or signage immediately.

General – Concerning your safety

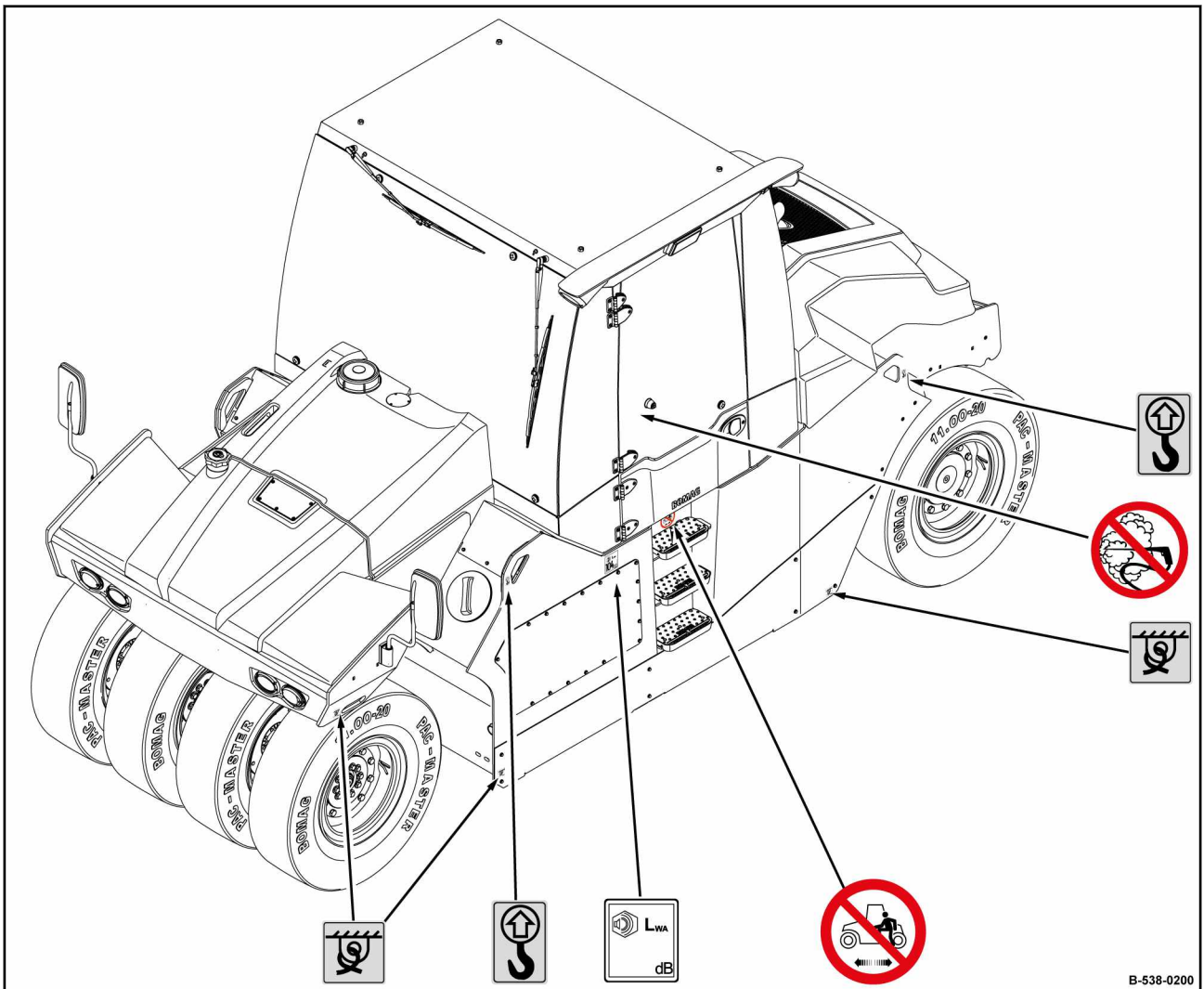
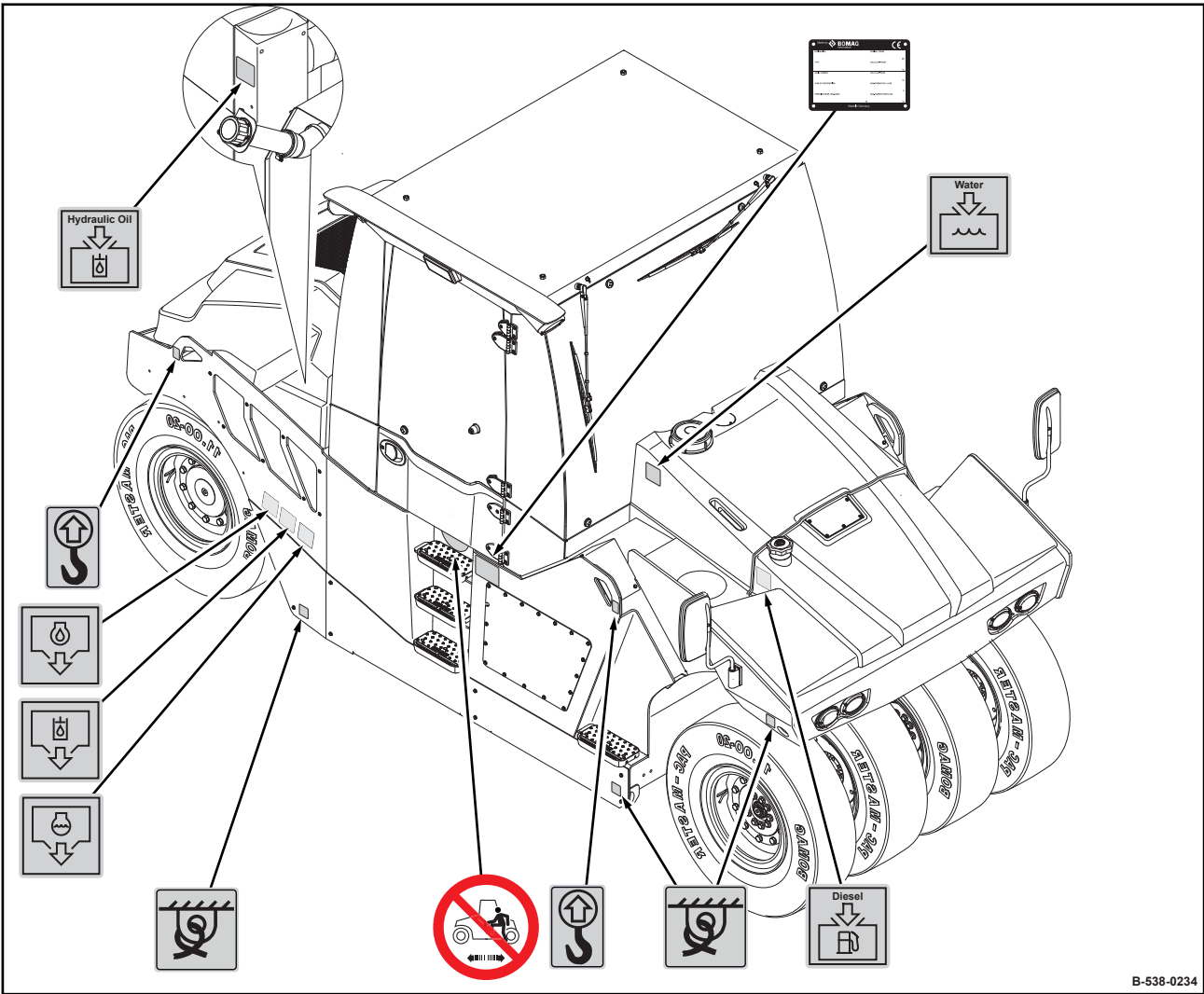

Fig. 8



B-538-0234

Fig. 9

General – Concerning your safety

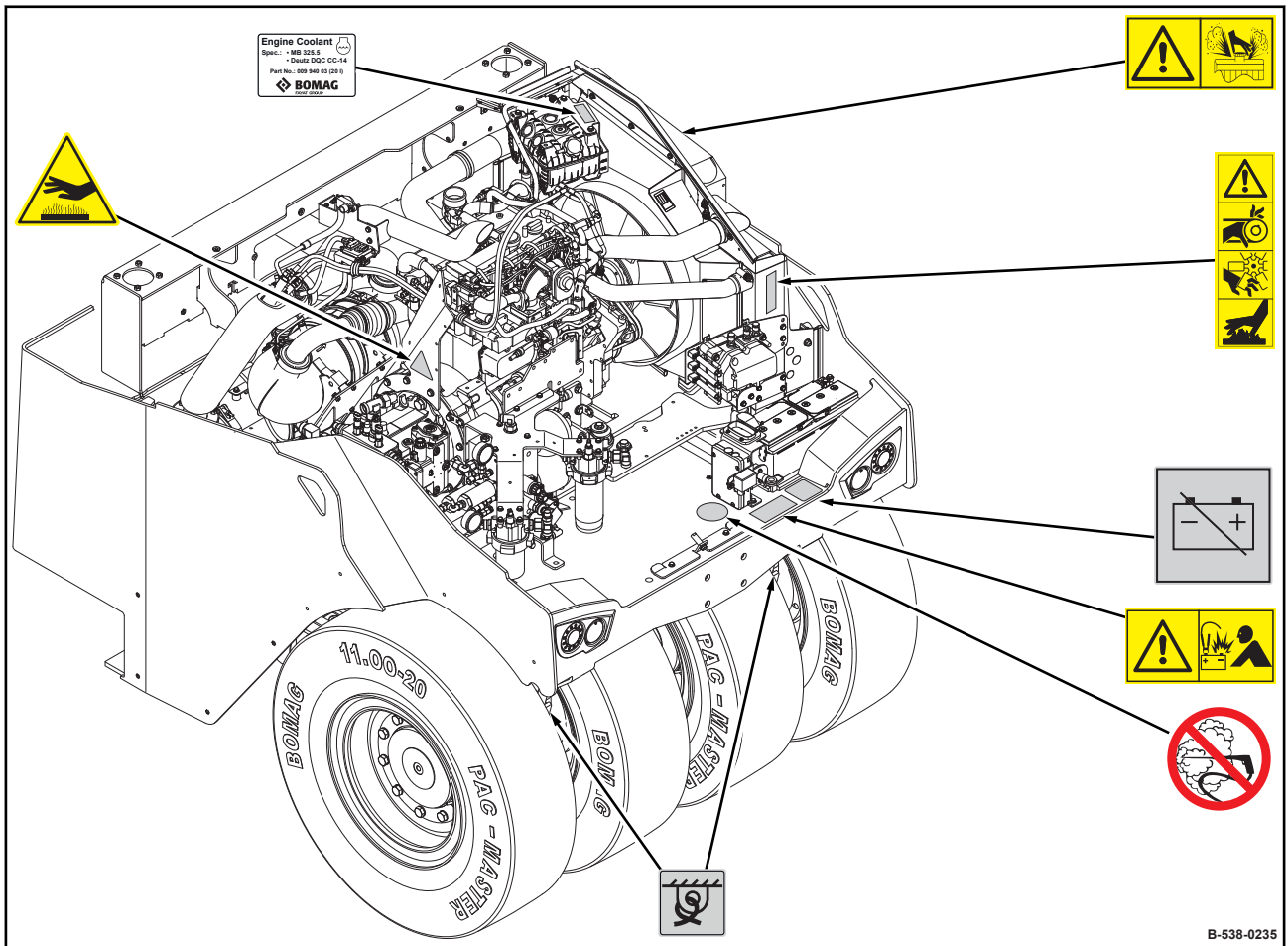

Fig. 10



Fig. 11

Warning sticker - Hot surface



Warning sticker - Danger of scalding when opening the cooler seal

Fig. 12



Warning sticker - Danger of being pulled in by belt drive and cooling fan and hot surface

Fig. 13



Warning sticker - Explosion hazard battery

Fig. 14



Warning sticker - Follow operating instructions

Fig. 15

General – Concerning your safety



Prohibition sticker - High pressure cleaning

Fig. 16



Prohibition sticker - Entering and exiting the machine during travel

Fig. 17

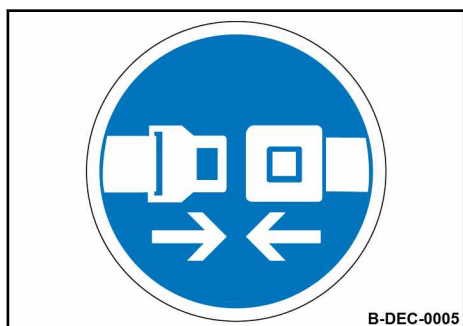

Instruction sticker - Always wear your seat belt

Fig. 18

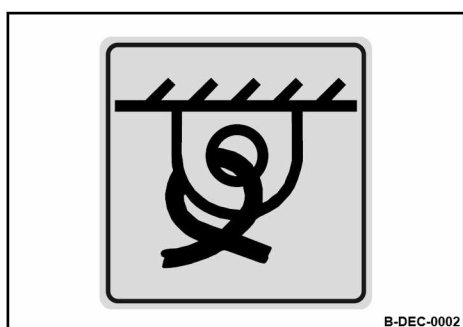

Information sticker - Lashing point

Fig. 19

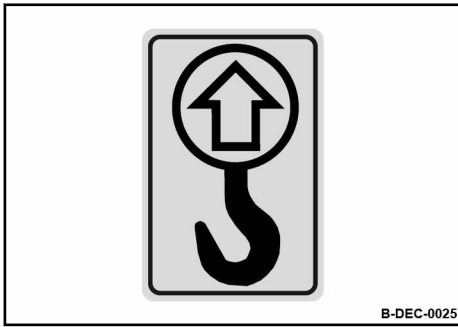

Information sticker - Lifting point

Fig. 20

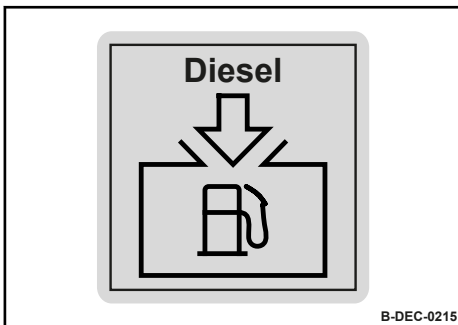

Information sticker - Filler opening for diesel

Fig. 21

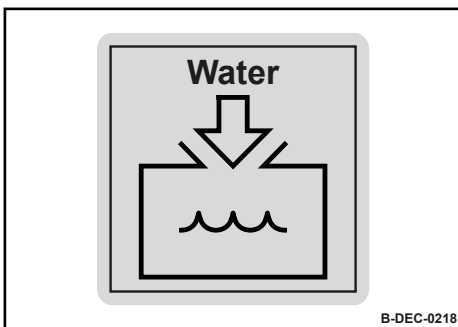

Information sticker - Filler opening for water

Fig. 22

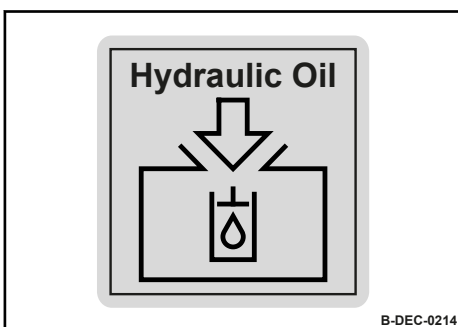

Information sticker - Filler opening for hydraulic oil

Fig. 23

General – Concerning your safety

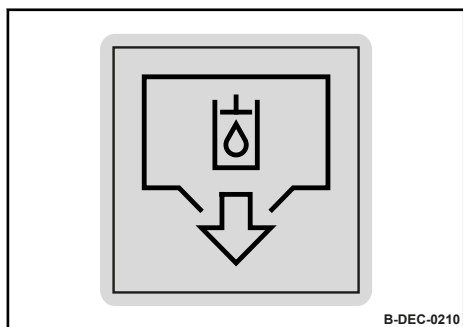

Information sticker - Hydraulic oil drain

Fig. 24

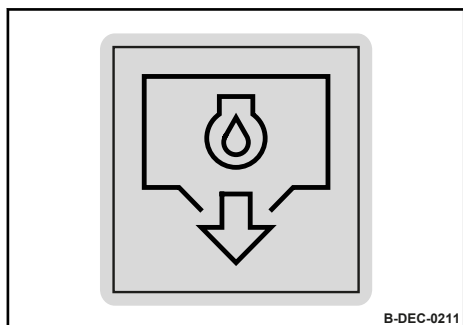

Information sticker - Engine oil drain

Fig. 25

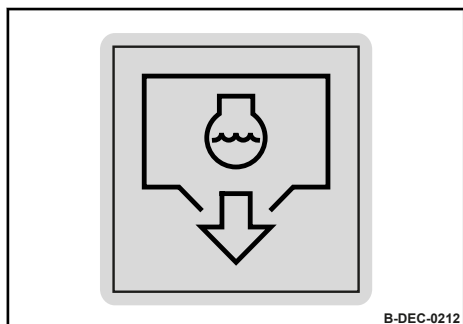

Information sticker - Coolant drain

Fig. 26

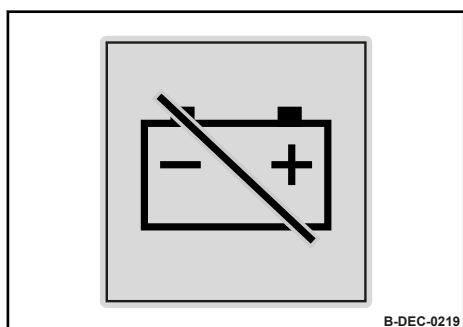

Information sticker - Disconnecting the battery

Fig. 27

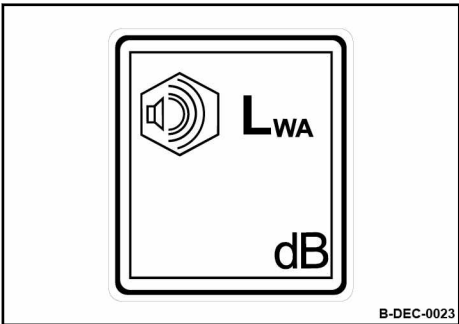

Information sticker - Guaranteed sound capacity level

Fig. 28

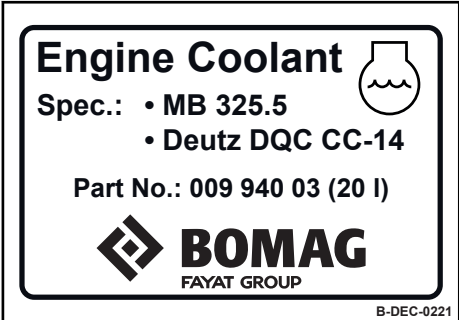

Information sticker - Coolant

Fig. 29

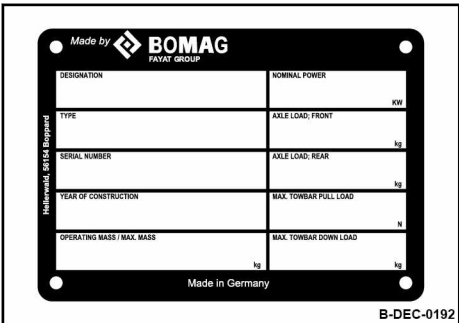

Machine type plate (example)

Fig. 30

1.2.13 Safety Components

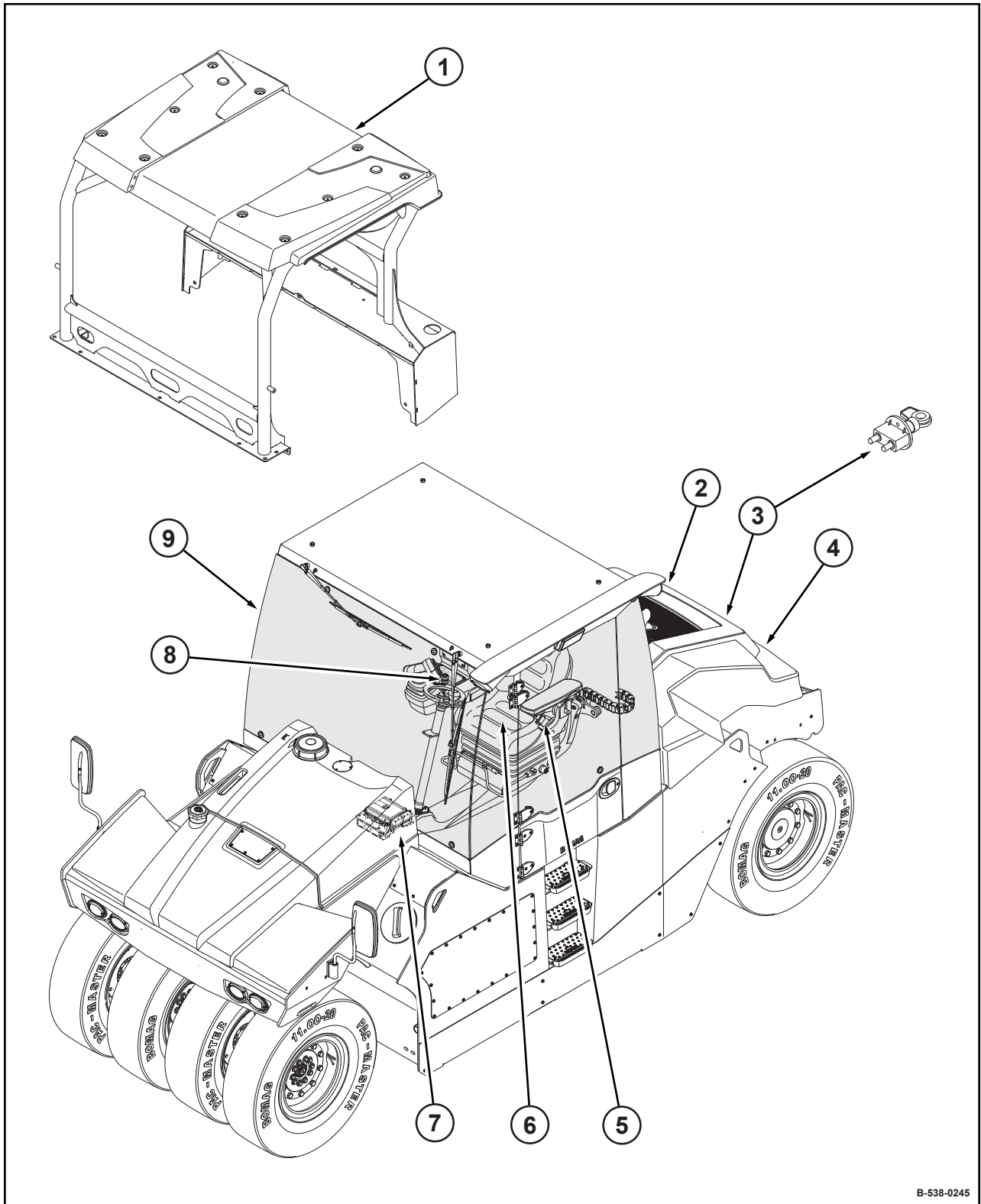

B-538-0245

Fig. 31

1 ROPS/FOPS (optional equipment)

This as a preview PDF file from best-manuals.com



Download full PDF manual at best-manuals.com