

**JD743-A
Tree Harvester
JD743-A
Feller-Buncher**

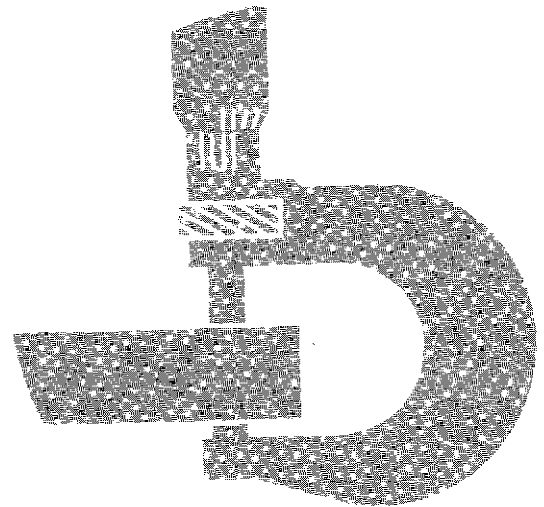

TECHNICAL MANUAL

TM-1226
LITHO IN U.S.A.

SECTION AND GROUP CONTENTS OF THIS MANUAL

SECTION I - GENERAL INFORMATION

- Group I - Contents, Index and Page List
- Group II - Introduction and Safety Information
- Group III - General Specifications
- Group IV - Predelivery, Delivery and After-Sales Services
- Group V - Lubrication

SECTION 1 - WHEELS

- Group 0110 - Powered Wheels, Tires and Fastenings
- Group 0199 - Specifications and Special Tools

SECTION 2 - AXLES AND SUSPENSION SYSTEMS

- Group 0201 - Drive Axle Housing and Support
- Group 0210 - Differential or Bevel Drive
- Group 0225 - Input Drive Shaft and U-Joints
- Group 0243 - Axle Lock Mounting
- Group 0250 - Axle Shaft, Bearings, Reduction Gears
- Group 0260 - Hydraulic System
- Group 0299 - Specifications and Special Tools

SECTION 3 - TRANSMISSION

- Group 0315 - Controls
- Group 0325 - Input Drive Shafts and U-Joints
- Group 0341 - Housings and Covers
- Group 0342 - Mounting Parts
- Group 0350 - Gears, Shafts, Bearings and Power Shift Clutch
- Group 0360 - Hydraulic System
- Group 0370 - Clutch Disconnect and Controls
- Group 0399 - Specifications and Special Tools

SECTION 4 - ENGINE

- Group 0400 - Engine Removal and Installation
- Group 0401 - Crankshaft and Main Bearings
- Group 0402 - Camshaft and Valve Actuating Means
- Group 0403 - Connecting Rods and Pistons
- Group 0404 - Cylinder Block
- Group 0407 - Oiling System
- Group 0408 - Ventilating System
- Group 0409 - Cylinder Head and Valves
- Group 0410 - Exhaust Manifold
- Group 0413 - Fuel Injection System
- Group 0414 - Intake Manifold
- Group 0416 - Turbocharger
- Group 0417 - Water Pump
- Group 0418 - Thermostats, Housings and Water Piping
- Group 0419 - Oil Cooler
- Group 0420 - Fuel Filter
- Group 0422 - Starting Motor and Fastenings
- Group 0429 - Fan Drive
- Group 0433 - Flywheel, Housing and Fastenings
- Group 0499 - Specifications and Special Tools

SECTION 5 - ENGINE AUXILIARY SYSTEMS

- Group 0505 - Cold Weather Starting Aids
- Group 0510 - Cooling Systems
- Group 0515 - Engine Speed Controls
- Group 0520 - Intake Systems
- Group 0503 - External Exhaust Systems
- Group 0540 - Mounting Frame
- Group 0560 - External Fuel Supply Systems
- Group 0599 - Specifications and Special Tools

The specifications and design information contained in this manual were correct at the time it was printed. It is John Deere's policy to continually improve and update our machines. Therefore, the specifications and design information are subject to change without notice. Wherever applicable, specifications and design information are in accordance with SAE and ICED standards.

Copyright 1980
DEERE & COMPANY
Moline, Illinois
All Rights Reserved

00-A

SECTION AND GROUP CONTENTS OF THIS MANUAL—Continued

SECTION 9 - STEERING SYSTEM

- Group 0930 - Emergency Steering
- Group 0960 - Hydraulic System
- Group 0999 - Specifications and Special Tools

SECTION 10 - SERVICE BRAKES

- Group 1011 - Active Elements
- Group 1015 - Controls Linkage
- Group 1060 - Hydraulic System
- Group 1099 - Specifications and Special Tools

SECTION 11 - PARKING-EMERGENCY BRAKES

- Group 1111 - Active Elements
- Group 1115 - Controls Linkage
- Group 1199 - Specifications and Special Tools

SECTION 16 - ELECTRICAL SYSTEM

- Group 1671 - Batteries, Support and Cables
- Group 1672 - Alternator, Regulator and Charging System Wiring
- Group 1673 - Lighting System
- Group 1674 - Wiring Harness and Switches
- Group 1675 - System Controls
- Group 1676 - Instruments and Indicators
- Group 1699 - Specifications and Special Tools

SECTION 17 - FRAMES, CHASSIS OR SUPPORTING STRUCTURE

- Group 1740 - Frame Installation
- Group 1746 - Frame Bottom Guards
- Group 1799 - Specifications and Special Tools

SECTION 18 - OPERATOR'S STATION

- Group 1810 - Operator Enclosure
- Group 1821 - Seat and Seat Belt
- Group 1830 - Heating and Air Conditioning
- Group 1899 - Specifications and Special Tools

SECTION 19 - SHEET METAL AND STYLING

- Group 1910 - Hood or Engine Enclosure
- Group 1913 - Miscellaneous Shields
- Group 1921 - Grille and Grille Housing

SECTION 20 - SAFETY, CONVENIENCE AND MISCELLANEOUS

- Group 2001 - Radio
- Group 2002 - Mirror
- Group 2003 - Fire Extinguisher
- Group 2004 - Horn
- Group 2006 - Cigar Lighter
- Group 2099 - Specifications and Special Tools

SECTION 21 - MAIN HYDRAULIC SYSTEM

- Group 2160 - Hydraulic System
- Group 2199 - Specifications and Special Tools

SECTION 32 - BULLDOZERS

- Group 3201 - Blades
- Group 3215 - Controls Linkage
- Group 3260 - Hydraulic System
- Group 3299 - Specifications and Special Tools

SECTION 37 - ARCH OR BOOM, OR CRANES

- Group 3715 - Controls Linkage
- Group 3740 - Frames
- Group 3760 - Hydraulic System
- Group 3799 - Specifications and Special Tools

SECTION 38 - GRAPPLE

- Group 3803 - Grapple Mechanism
- Group 3813 - Shielding
- Group 3860 - Hydraulic System
- Group 3899 - Specifications and Special Tools

SECTION 39 - SHEAR

- Group 3901 - Blades and Cutting Elements
- Group 3903 - Tongue and Forks
- Group 3915 - Controls Linkage
- Group 3940 - Frame
- Group 3960 - Hydraulic System
- Group 3999 - Specifications and Special Tools

SECTION AND GROUP CONTENTS OF THIS MANUAL—Continued

SECTION 41 - MISCELLANEOUS FUNCTION MECHANICAL DRIVE

- Group 4125 - Input Drive Shafts
- Group 4141 - Housings and Covers
- Group 4151 - Gears, Shafts and Bearings
- Group 4152 - Clutch
- Group 4160 - Hydraulic System
- Group 4199 - Specifications and Special Tools

SECTION 43 - SWING, ROTATION OR PIVOTING SYSTEM

- Group 4315 - Controls
- Group 4350 - Mechanical Drive Elements
- Group 4360 - Hydraulic System
- Group 4399 - Specifications and Special Tools

SECTION 44 - CUTTING MECHANISMS

- Group 4401 - Blades
- Group 4440 - Frames
- Group 4460 - Hydraulic System
- Group 4499 - Specifications and Special Tools

SECTION 90 - SYSTEM TESTING

- Group 9005 - General Information
- Group 9010 - Engine
- Group 9015 - Electrical System
- Group 9015A - Electrical System (Automatic Control)
- Group 9020 - Power Train
- Group 9025 - Hydraulic System (Flow Meter)
- Group 9030 - Miscellaneous Components
- Group 9031 - Heating and Air Conditioning
- Group 9035 - Specifications and Special Tools

ALPHABETICAL INDEX

A

Accumulator, brake	1060-4
Active elements, service brakes	1011-3
After sales inspection	I-IV-27
Air conditioning and heating system testing	9031-1
Air filters	1830-34
Alternator, regulator and charging system wiring	1672-1
Automatic control circuit schematic	9015A-46
Axle housing	0250-4
Axle lock mounting	0243-1
Axle shaft, bearings, reduction gears	0250-1
Axle stabilizer cylinder	0260-7
Axle stabilizer valve	0260-1, 9025-18
Axle stabilizer valve testing	9015-32

B

Batteries, support and cables	1671-3
Blade control valve, bulldozers	3260-1
Blades and cutting elements	3901-3
Blades, bulldozer	3201-3
Blades (delimber knives)	4401-3
Block diagram	9015-3, 9015A-6
Blower motor	1830-32
Brake accumulator	1060-4, 9025-10
Brake system lines	1060-8
Brake valve	9025-11

C

C1 - C2 accumulators	0360-12
Camshaft and valve actuating means	0402-1
Cigar lighter	2006-1
Circuit protectors	1674-1
Clutch housings, transmission	0350-11
Clutch, mechanical drive	4152-1
Clutch valve linkage	0315-3
Cold weather starting aids	0505-3
Compressor	1830-5
Compressor relief valve	1830-30
Condenser	1830-21
Connecting rods and pistons	0403-1
Controls linkage, arch or boom	3715-3
Controls linkage, bulldozer	3215-1
Controls, swing, rotation system	4315-3
Cooling system	0510-1
Crankshaft and main bearings	0401-1
Cylinder block	0404-1
Cylinder, bulldozer	3260-5
Cylinder, delimber knives and feed rolls	4460-18
Cylinder head and valves	0409-1
Cylinders, steering	0960-10

D

(Delimber carriage), frames	4440-1
Delimber knives and feed rolls cylinders	4460-18
Delimber knives and feed roll valve	4460-1, 9025-22
Delivery service	I-IV-27
Diagnosing malfunctions	9015A-11, 9025-45
Differential housing with lock	0210-4
Differential case and cover	0210-1
Differential drive shaft, front	0225-3
Differential drive shaft, rear	0225-1
Differential, front	0210-1
Differential lock valve	0210-32, 9025-16
Differential lock valve hydraulics	0210-34
Differential or bevel drive	0210-1
Differential, rear	0210-1
Drive axle housing and support	0201-3

E

Electrical schematic complete	9015-43
Emergency steering	0930-3
Emergency steering accumulator	0930-3
Emergency steering low pressure warning switch	0930-6, 9025-15
Engine coolant heater	0505-5
Engine oil cooler	0419-1
Engine oiling system	0407-1
Engine removal and installation	0400-3
Engine system testing	9010-1
Engine ventilating system	0408-1
Evaporator core	1830-26
Exhaust manifold	0410-1
Expansion valve	1830-28
External exhaust systems	0530-1
External fuel supply systems	0560-1

F

Fan	0510-1
Fan belt tightener	0429-1
Fan drive	0429-1
Fan drive support	0429-3
Fire extinguisher	2003-1
Fire stack valve	9025-26
Fire suppression system	9015-41
Flywheel, housing and fastenings	0433-1
Forks and tongue	3903-3
Frames - arch or boom	3740-1
Frames (delimber carriage)	4440-1
Front differential	0210-1
Front differential drive shaft	0225-3
Fuel filter	0420-1
Fuel injection nozzles	0413-9
Fuel injection pump	0413-5
Fuel injection system	0413-1

Fuel line 0560-6
Fuel supply pump 0560-1
Fuel tank 0560-4
Fuel transfer pump 0413-1
Frame bottom guards 1746-1
Frame installation 1740-3

G

Gears, shafts and bearings, mechanical drive 4151-1
General information 9015A-5
General specifications I-III-1
Grapple hydraulic system 3860-1
Grapple mechanism 3803-3
Grapple shielding 3813-1
Grille and grille housing 1921-1

H

Harvesting control box wiring 9015A-45
Heater blowers 1830-4
Heater core 1830-2
Heater valve 1830-1
Heater pipes and hoses 1830-4
Heating and air conditioning system testing . 9031-1
Hood or engine enclosure 1910-3
Horn 2004-1
Housing and covers 0341-1
Housing and covers, mechanical drive 4141-1
Hydraulic charge pump 2160-25
Hydraulic in-line filter 2160-47
Hydraulic manifold 2160-37
Hydraulic oil cooler and check valve 2160-45
Hydraulic oil filters 2160-39
Hydraulic pump 2160-6
Hydraulic pump destroke solenoid 9015-32
Hydraulic reservoir 2160-41
Hydraulic schematics 9025-105
Hydraulic service recommendations 2160-3
Hydraulic steering valve 0960-1
Hydraulic system 0260-1
Hydraulic system accumulator 2160-33
Hydraulic system, arch or boom 3760-1
Hydraulic system, cutting mechanism 4460-1
Hydraulic system, grapple 3860-1
Hydraulic system, mechanical drive 4160-1
Hydraulic system, steering 0960-1
Hydraulic system, swing and rotation system 4360-1
Hydraulic warm-up switch 9015-35

I

Indicator isolation diodes 1674-7
Input drive shafts and U-joints 0225-1, 0325-1
Input drive shafts, mechanical drive 4125-1
Instruments and indicators 1676-2
Instruments and indicators, testing 9015-25
Intake manifold 0414-1

Intake manifold pressure test 9010-19
Intake system 0520-1
Introduction I-II-1

L

Lighting system 1673-1
Lighting system testing 9015-16
Log accumulator 9015-40
Log accumulator valve 9025-29
Lubrication I-V-1

M

Main hydraulic pump 9025-3
Mechanical drive elements, swing, rotating
▪ system 4350-1
Mirror 2002-1
Miscellaneous accessories 9015-28
Miscellaneous components system testing . 9030-1
Miscellaneous shields 1913-1
Mounting frame 0540-1
Mounting parts 0342-1
Multi stem shear operation 9025-32
Multi-stem shear valve . 3960-15, 9015-35, 9025-30

O

Operator enclosure 1810-3
Oscillating supports, differential 0210-20

P

Parking-emergency brakes active elements . 1111-3
Parking-emergency brakes control linkage . 1115-1
Planet pinion carrier 0250-4
Planetary pack 0350-27
Power shaft countershaft 0350-42
Power shift transmission assembly 0350-5
Power train system testing 9020-1
Precautions 9015A-10
Predelivery service I-IV-1
Pressure control valve 2160-29, 9025-8
Pressure reducing valve . 4460-14, 9015-40, 9025-27
Pump drive and support assembly 2160-33

R

Radiator and fan shroud 0510-2
Radio 2001-3
Rear differential 0210-1
Rear differential drive shaft 0225-1
Receiver-dryer 1830-24
Relays 1674-3, 1674-4

S

Seat 1821-1
Seat belt 1821-1
Service brake valve 1060-1
Service brakes active elements 1011-3
Service brakes controls linkage 1015-1

Shear and grapple control valve	3960-1
Shear cylinder.....	3960-19
Shear frame	3940-1
Shear grapple cylinder	3960-29
Shear/grapple valve	9015-35
Shear hydraulic system	3960-1
Shears controls linkage	3915-1
Shorted circuit test.....	9015A-10
Special procedures	9025-49
Special tools:	
Air conditioning system	1899-6
Alternator, regulator and charging system wiring	1699-7
Batteries, support and cables	1699-5
Camshaft and valve actuating means....	0499-29
Clutch disconnect and controls, transmission	0399-26
Clutch, mechanical drive	4199-2
Connecting rods and pistons	0499-31
Cooling system	0599-4
Crankshaft and main bearings	0499-28
Cylinder block.....	0499-32
Cylinder head and valves	0499-34
Electrical system	9035-15
Electrical system (automatic control)....	9035-19
Emergency steering accumulator	0999-6
Emergency steering valve	0999-7
Engine	9035-3
Fuel injection system	0499-36
Gears, shafts, bearings and power shift clutch transmission	0399-23
Grapple hydraulic system	3899-3
Housing and covers, transmission	0399-22
Hydraulic system	0299-13, 2199-11
Hydraulic system, arch or boom	3799-5
Hydraulic system, bulldozer	3299-3
Hydraulic system, cutting mechanisms....	4499-2
Hydraulic system (flow meter)	9035-27
Operating enclosure	1899-4
Removal and installation, engine	0499-25
Service brakes hydraulic system	1099-3
Shear blades and cutting elements.....	3999-7
Shear hydraulic system	3999-8
Starting motor and fastenings.....	0499-40
Turbocharger	0499-38
Water pump	0499-39
Wheels and fastening	0199-2
Specifications:	
Air conditioning system	1899-2
Alternator, regulator and charging system wiring	1699-1
Axle lock mount.....	0299-10
Axle shafts, bearing, reduction gears	0299-10
Basic engine.....	9035-1
Batteries, support and cables	1699-1

Specifications (Continued):	
Blades, cutting mechanisms	4499-1
Camshaft and valve actuating means.....	0499-3
Clutch disconnect and controls, transmission	0399-20
Cold weather starting aids	0599-1
Connecting rods and pistons	0499-5
Cooling systems	0599-1
Crankshaft and main bearings	0499-2
Cylinder block.....	0499-8
Cylinder head and valves	0499-12
Differential or bevel drive.....	0299-2
Drive axle housing and support	0299-1
Electrical system	9035-5
Electrical system (automatic control)....	9035-17
Emergency steering accumulator	0999-1
Emergency steering cylinder	0999-5
Emergency steering valve	0999-1
Engine break-in	0499-1
Engine oil cooler	0499-21
Engine oiling system	0499-10
External fuel supply system	0599-4
Fan drive.....	0499-24
Fire extinguisher	2099-1
Flywheel housing and fastenings	0499-24
Frame installation	1799-1
Frames, cutting mechanisms	4499-1
Fuel injection system	0499-15
Gears, shafts and bearings, mechanical drive	4199-3
Grapple hydraulic system	3899-1
Heating and air conditioning	9035-30
Housing and covers, mechanical drive....	4199-2
Hydraulic system	0299-11
Hydraulic system, arch or boom	3799-1
Hydraulic system, bulldozers	3299-1
Hydraulic system, cutting mechanisms....	4499-2
Hydraulic system (flow meter)	9035-22
Hydraulic system, mechanical drive	4199-11
Hydraulic system, swing and rotation system	4399-3
Hydraulic system, transmission	0399-3
Input drive shafts and U-joints	0299-9
Input drive shaft, mechanical drive	4199-1
Instruments and indicators	1699-4
Intake manifold	0499-17
Intake system	0599-3
Lighting system	1699-3
Miscellaneous components	9035-29
Mechanical drive elements, swing and rotation system	4399-1
Mounting frame	0599-4
Operator enclosure	1899-1

Specifications (Continued):

- Parking brake active elements 1199-1
- Parking-emergency brakes controls linkage 1199-1
- Power train 9035-21
- Service brakes hydraulic system 1099-1
- Shears, blades and cutting elements 3999-1
- Shear frames 3999-2
- Shear hydraulic system 3999-4
- Speed controls 0599-2
- Starting motor and fastenings 0499-22
- System controls 1699-4
- Thermostats, housings and water piping 0499-20
- Transmission gears, shafts, bearings and power shift clutch 0399-3
- Transmission input drive shafts and U-joints 0399-1
- Transmission mounting parts 0399-2
- Turbocharger 0499-18
- Water pump 0499-19
- Wheels and fastenings 0199-1
- Wiring harness and switches 1699-3
- Speed controls 0515-1
- Stabilizer cylinder, axle 0260-7
- Stabilizer valve, axle 0260-1
- Starting circuit 9015-11
- Starting motor and fastenings 0422-1
- Steering cylinders 0960-10
- Steering system lines 0960-13
- Steering valve 9025-12
- Stroke control valve 2160-6
- Stroke control valve assembly 9025-3
- Surge relief valve 9025-8
- Swing crossover relief valve 9025-25
- Swing motor 9025-24
- Switches 1674-4, 1674-6
- System accumulator 9025-9
- System controls 1675-1
- System testing, engine 9010-1
- System testing, heating and air conditioning 9031-1
- System testing, miscellaneous components 9030-1
- System testing, power train 9020-1

T

- Test port locations 9025-39
- Test procedures 9015A-12
- Testing and adjustment 9025-54
- Thermal fuse and superheat shut-off switch 1830-31
- Thermostats, housings and water piping 0418-1
- Thermostats temperature control switch 1830-29

- Tongue and forks 3909-3
- Transmission case 0350-15
- Transmission clutch carrier assembly and elements 0370-1
- Transmission clutch linkage 0370-7
- Transmission clutch pack 0350-2
- Transmission clutch valve 0360-8
- Transmission clutch valve assembly 0360-4
- Transmission control valve shift linkage 0315-5
- Transmission hydraulic system 9025-35
- Transmission oil cooler 0360-16
- Transmission oil filter 0360-13
- Transmission oil pressure regulating valve 0360-10
- Transmission oil pump 0360-1
- Transmission suction screen filter 0350-1
- Turbocharger 0416-1

V

- Valve, axle stabilizer 9025-18
- Valve, brake 9025-11
- Valve, delimeter knives and feed roll 4460-1
- Valve, differential lock 9025-16
- Valve, fire stack 9025-26
- Valve, heater 1830-1
- Valve, log accumulator 9025-29
- Valve, multi stem shear 9025-30
- Valve, pressure control 9025-8
- Valve, pressure reducing 4460-14, 9015-40, 9025-27
- Valve, service brake 1060-1
- Valve, steering 0960-1, 9025-12
- Valve, surge relief 9025-8
- Valve, swing crossover relief 9025-25
- Vibration damper 0401-8
- Visual inspection 9015A-10, 9025-48

W

- Water pump 0417-1
- Wheel and fastenings 0110-3
- Wire terminal location 9015A-7
- Wiring diagram, complete 9015-45
- Wiring harnesses and switches 1674-1

**COMPLETE PAGE LISTING
 WITH LATEST DATE LINES**

I-I-1,2	(May-80)	1-0110-1,2	(May-80)	3-0315-1,2	(May-80)
I-I-3,4	(May-80)	1-0110-3,4	(May-80)	3-0315-3,4	(May-80)
I-I-5,6	(May-80)	1-0110-5,6	(May-80)	3-0315-5,6	(May-80)
I-I-7,8	(May-80)	1-0199-1,2	(May-80)	3-0325-1,2	(May-80)
I-I-9,10	(May-80)			3-0341-1,2	(May-80)
I-I-11,12	(May-80)	2-0201-1,2	(May-80)	3-0341-3,4	(May-80)
I-I-13,14	(May-80)	2-0201-3,4	(May-80)	3-0341-5,6	(May-80)
I-II-1,2	(May-80)	2-0201-5,6	(May-80)	3-0341-7,8	(May-80)
I-II-3,4	(May-80)	2-0201-7,8	(May-80)	3-0342-1,2	(May-80)
I-II-5,6	(May-80)	2-0210-1,2	(May-80)	3-0350-1,2	(May-80)
I-II-7,8	(May-80)	2-0210-3,4	(May-80)	3-0350-3,4	(May-80)
I-III-1,2	(May-80)	2-0210-5,6	(May-80)	3-0350-5,6	(May-80)
I-III-3,4	(May-80)	2-0210-7,8	(May-80)	3-0350-7,8	(May-80)
I-III-5,6	(May-80)	2-0210-9,10	(May-80)	3-0350-9,10	(May-80)
I-IV-1,2	(May-80)	2-0210-11,12	(May-80)	3-0350-11,12	(May-80)
I-IV-3,4	(May-80)	2-0210-13,14	(May-80)	3-0350-13,14	(May-80)
I-IV-5,6	(May-80)	2-0210-15,16	(May-80)	3-0350-15,16	(May-80)
I-IV-7,8	(May-80)	2-0210-17,18	(May-80)	3-0350-17,18	(May-80)
I-IV-9,10	(May-80)	2-0210-19,20	(May-80)	3-0350-19,20	(May-80)
I-IV-11,12	(May-80)	2-0210-21,22	(May-80)	3-0350-21,22	(May-80)
I-IV-13,14	(May-80)	2-0210-23,24	(May-80)	3-0350-23,24	(May-80)
I-IV-15,16	(May-80)	2-0210-25,26	(May-80)	3-0350-25,26	(May-80)
I-IV-17,18	(May-80)	2-0210-27,28	(May-80)	3-0350-27,28	(May-80)
I-IV-19,20	(May-80)	2-0210-29,30	(May-80)	3-0350-29,30	(May-80)
I-IV-21,22	(May-80)	2-0210-31,32	(May-80)	3-0350-31,32	(May-80)
I-IV-23,24	(May-80)	2-0210-33,34	(May-80)	3-0350-33,34	(May-80)
I-IV-25,26	(May-80)	2-0210-35,36	(May-80)	3-0350-35,36	(May-80)
I-IV-27,28	(May-80)	2-0225-1,2	(May-80)	3-0350-37,38	(May-80)
I-IV-29,30	(May-80)	2-0225-3,4	(May-80)	3-0350-39,40	(May-80)
I-IV-31,32	(May-80)	2-0243-1,2	(May-80)	3-0350-41,42	(May-80)
I-IV-33,34	(May-80)	2-0250-1,2	(May-80)	3-0350-43,44	(May-80)
I-IV-35,36	(May-80)	2-0250-3,4	(May-80)	3-0350-45,46	(May-80)
I-IV-37,38	(May-80)	2-0250-5,6	(May-80)	3-0350-47,48	(May-80)
I-IV-39,40	(May-80)	2-0260-1,2	(May-80)	3-0350-49,50	(May-80)
I-IV-41,42	(May-80)	2-0260-3,4	(May-80)	3-0350-51,52	(May-80)
I-IV-43,44	(May-80)	2-0260-5,6	(May-80)	3-0350-53,54	(May-80)
I-IV-45,46	(May-80)	2-0260-7,8	(May-80)	3-0350-55,56	(May-80)
I-IV-47,48	(May-80)	2-0260-9,10	(May-80)	3-0350-57,58	(May-80)
I-IV-49,50	(May-80)	2-0299-1,2	(May-80)	3-0350-59,60	(May-80)
I-IV-51,52	(May-80)	2-0299-3,4	(May-80)	3-0360-1,2	(May-80)
I-IV-53,54	(May-80)	2-0299-5,6	(May-80)	3-0360-3,4	(May-80)
I-IV-55,56	(May-80)	2-0299-7,8	(May-80)	3-0360-5,6	(May-80)
I-IV-57,58	(May-80)	2-0299-9,10	(May-80)	3-0360-7,8	(May-80)
I-V-1,2	(May-80)	2-0299-11,12	(May-80)	3-0360-9,10	(May-80)
		2-0299-13,14	(May-80)	3-0360-11,12	(May-80)

COMPLETE PAGE LISTING—Continued

3-0360-13,14	(May-80)	4-0407-1,2	(May-80)	4-0499-13,14	(May-80)
3-0360-15,16	(May-80)	4-0407-3,4	(May-80)	4-0499-15,16	(May-80)
3-0370-1,2	(May-80)	4-0407-5,6	(May-80)	4-0499-17,18	(May-80)
3-0370-3,4	(May-80)	4-0408-1,2	(May-80)	4-0499-19,20	(May-80)
3-0370-5,6	(May-80)	4-0409-1,2	(May-80)	4-0499-21,22	(May-80)
3-0370-7,8	(May-80)	4-0409-3,4	(May-80)	4-0499-23,24	(May-80)
3-0399-1,2	(May-80)	4-0409-5,6	(May-80)	4-0499-25,26	(May-80)
3-0399-3,4	(May-80)	4-0410-1,2	(May-80)	4-0499-27,28	(May-80)
3-0399-5,6	(May-80)	4-0413-1,2	(May-80)	4-0499-29,30	(May-80)
3-0399-7,8	(May-80)	4-0413-3,4	(May-80)	4-0499-31,32	(May-80)
3-0399-9,10	(May-80)	4-0413-5,6	(May-80)	4-0499-33,34	(May-80)
3-0399-11,12	(May-80)	4-0413-7,8	(May-80)	4-0499-35,36	(May-80)
3-0399-13,14	(May-80)	4-0413-9,10	(May-80)	4-0499-37,38	(May-80)
3-0399-15,16	(May-80)	4-0413-11,12	(May-80)	4-0499-39,40	(May-80)
3-0399-17,18	(May-80)	4-0413-13,14	(May-80)	4-0499-41,42	(May-80)
3-0399-19,20	(May-80)	4-0413-15,16	(May-80)		
3-0399-21,22	(May-80)	4-0413-17,18	(May-80)	5-0505-1,2	(May-80)
3-0399-23,24	(May-80)	4-0413-19,20	(May-80)	5-0505-3,4	(May-80)
3-0399-25,26	(May-80)	4-0414-1,2	(May-80)	5-0505-5,6	(May-80)
		4-0414-3,4	(May-80)	5-0510-1,2	(May-80)
4-0400-1,2	(May-80)	4-0416-1,2	(May-80)	5-0510-3,4	(May-80)
4-0400-3,4	(May-80)	4-0416-3,4	(May-80)	5-0510-5,6	(May-80)
4-0400-5,6	(May-80)	4-0416-5,6	(May-80)	5-0515-1,2	(May-80)
4-0400-7,8	(May-80)	4-0416-7,8	(May-80)	5-0515-3,4	(May-80)
4-0400-9,10	(May-80)	4-0417-1,2	(May-80)	5-0520-1,2	(May-80)
4-0400-11,12	(May-80)	4-0417-3,4	(May-80)	5-0530-1,2	(May-80)
4-0400-13,14	(May-80)	4-0417-5,6	(May-80)	5-0540-1,2	(May-80)
4-0401-1,2	(May-80)	4-0417-7,8	(May-80)	5-0560-1,2	(May-80)
4-0401-3,4	(May-80)	4-0418-1,2	(May-80)	5-0560-3,4	(May-80)
4-0401-5,6	(May-80)	4-0419-1,2	(May-80)	5-0560-5,6	(May-80)
4-0401-7,8	(May-80)	4-0420-1,2	(May-80)	5-0599-1,2	(May-80)
4-0402-1,2	(May-80)	4-0422-1,2	(May-80)	5-0599-3,4	(May-80)
4-0402-3,4	(May-80)	4-0422-3,4	(May-80)		
4-0402-5,6	(May-80)	4-0422-5,6	(May-80)	9-0930-1,2	(May-80)
4-0402-7,8	(May-80)	4-0422-7,8	(May-80)	9-0930-3,4	(May-80)
4-0403-1,2	(May-80)	4-0422-9,10	(May-80)	9-0930-5,6	(May-80)
4-0403-3,4	(May-80)	4-0429-1,2	(May-80)	9-0960-1,2	(May-80)
4-0403-5,6	(May-80)	4-0429-3,4	(May-80)	9-0960-3,4	(May-80)
4-0403-7,8	(May-80)	4-0433-1,2	(May-80)	9-0960-5,6	(May-80)
4-0403-9,10	(May-80)	4-0499-1,2	(May-80)	9-0960-7,8	(May-80)
4-0404-1,2	(May-80)	4-0499-3,4	(May-80)	9-0960-9,10	(May-80)
4-0404-3,4	(May-80)	4-0499-5,6	(May-80)	9-0960-11,12	(May-80)
4-0404-5,6	(May-80)	4-0499-7,8	(May-80)	9-0960-13,14	(May-80)
4-0404-7,8	(May-80)	4-0499-9,10	(May-80)	9-0999-1,2	(May-80)
4-0404-9,10	(May-80)	4-0499-11,12	(May-80)	9-0999-3,4	(May-80)
				9-0999-5,6	(May-80)
				9-0999-7,8	(May-80)

COMPLETE PAGE LISTING—Continued

10-1011-1,2	(May-80)	17-1740-1,2	(May-80)	20-2003-1,2	(May-80)
10-1011-3,4	(May-80)	17-1740-3,4	(May-80)	20-2003-3,4	(May-80)
10-1015-1,2	(May-80)	17-1740-5,6	(May-80)	20-2003-5,6	(May-80)
10-1060-1,2	(May-80)	17-1740-7,8	(May-80)	20-2003-7,8	(May-80)
10-1060-3,4	(May-80)	17-1746-1,2	(May-80)	20-2003-9,10	(May-80)
10-1060-5,6	(May-80)	17-1799-1,2	(May-80)	20-2004-1,2	(May-80)
10-1060-7,8	(May-80)			20-2006-1,2	(May-80)
10-1099-1,2	(May-80)	18-1810-1,2	(May-80)	20-2099-1,2	(May-80)
10-1099-3,4	(May-80)	18-1810-3,4	(May-80)		
		18-1810-5,6	(May-80)	21-2160-1,2	(May-80)
11-1111-1,2	(May-80)	18-1810-7,8	(May-80)	21-2160-3,4	(May-80)
11-1111-3,4	(May-80)	18-1810-9,10	(May-80)	21-2160-5,6	(May-80)
11-1111-5,6	(May-80)	18-1810-11,12	(May-80)	21-2160-7,8	(May-80)
11-1115-1,2	(May-80)	18-1810-13,14	(May-80)	21-2160-9,10	(May-80)
11-1199-1,2	(May-80)	18-1821-1,2	(May-80)	21-2160-11,12	(May-80)
		18-1830-1,2	(May-80)	21-2160-13,14	(May-80)
16-1671-1,2	(May-80)	18-1830-3,4	(May-80)	21-2160-15,16	(May-80)
16-1671-3,4	(May-80)	18-1830-5,6	(May-80)	21-2160-17,18	(May-80)
16-1671-5,6	(May-80)	18-1830-7,8	(May-80)	21-2160-19,20	(May-80)
16-1671-7,8	(May-80)	18-1830-9,10	(May-80)	21-2160-21,22	(May-80)
16-1672-1,2	(May-80)	18-1830-11,12	(May-80)	21-2160-23,24	(May-80)
16-1672-3,4	(May-80)	18-1830-13,14	(May-80)	21-2160-25,26	(May-80)
16-1672-5,6	(May-80)	18-1830-15,16	(May-80)	21-2160-27,28	(May-80)
16-1672-7,8	(May-80)	18-1830-17,18	(May-80)	21-2160-29,30	(May-80)
16-1672-9,10	(May-80)	18-1830-19,20	(May-80)	21-2160-31,32	(May-80)
16-1672-11,12	(May-80)	18-1830-21,22	(May-80)	21-2160-33,34	(May-80)
16-1672-13,14	(May-80)	18-1830-23,24	(May-80)	21-2160-35,36	(May-80)
16-1672-15,16	(May-80)	18-1830-25,26	(May-80)	21-2160-37,38	(May-80)
16-1673-1,2	(May-80)	18-1830-27,28	(May-80)	21-2160-39,40	(May-80)
16-1674-1,2	(May-80)	18-1830-29,30	(May-80)	21-2160-41,42	(May-80)
16-1674-3,4	(May-80)	18-1830-31,32	(May-80)	21-2160-43,44	(May-80)
16-1674-5,6	(May-80)	18-1830-33,34	(May-80)	21-2160-45,46	(May-80)
16-1674-7,8	(May-80)	18-1899-1,2	(May-80)	21-2160-47,48	(May-80)
16-1675-1,2	(May-80)	18-1899-3,4	(May-80)	21-2199-1,2	(May-80)
16-1675-3,4	(May-80)	18-1899-5,6	(May-80)	21-2199-3,4	(May-80)
16-1675-5,6	(May-80)			21-2199-5,6	(May-80)
16-1675-7,8	(May-80)	19-1910-1,2	(May-80)	21-2199-7,8	(May-80)
16-1676-1,2	(May-80)	19-1910-3,4	(May-80)	21-2199-9,10	(May-80)
16-1676-3,4	(May-80)	19-1913-1,2	(May-80)	21-2199-11,12	(May-80)
16-1676-5,6	(May-80)	19-1921-1,2	(May-80)	21-2199-13,14	(May-80)
16-1676-7,8	(May-80)				
16-1699-1,2	(May-80)	20-2001-1,2	(May-80)		
16-1699-3,4	(May-80)	20-2001-3,4	(May-80)		
16-1699-5,6	(May-80)	20-2002-1,2	(May-80)		
16-1699-7,8	(May-80)				

COMPLETE PAGE LISTING—Continued

32-3201-1,2	(May-80)	39-3901-1,2	(May-80)	41-4151-7,8	(May-80)
32-3201-3,4	(May-80)	39-3901-3,4	(May-80)	41-4151-9,10	(May-80)
32-3201-5,6	(May-80)	39-3901-5,6	(May-80)	41-4151-11,12	(May-80)
32-3215-1,2	(May-80)	39-3901-7,8	(May-80)	41-4151-13,14	(May-80)
32-3215-3,4	(May-80)	39-3901-9,10	(May-80)	41-4151-15,16	(May-80)
32-3260-1,2	(May-80)	39-3903-1,2	(May-80)	41-4151-17,18	(May-80)
32-3260-3,4	(May-80)	39-3903-3,4	(May-80)	41-4151-19,20	(May-80)
32-3260-5,6	(May-80)	39-3915-1,2	(May-80)	41-4151-21,22	(May-80)
32-3260-7,8	(May-80)	39-3940-1,2	(May-80)	41-4151-23,24	(May-80)
32-3260-9,10	(May-80)	39-3940-3,4	(May-80)	41-4151-25,26	(May-80)
32-3299-1,2	(May-80)	39-3960-1,2	(May-80)	41-4151-27,28	(May-80)
32-3299-3,4	(May-80)	39-3960-3,4	(May-80)	41-4151-29,30	(May-80)
		39-3960-5,6	(May-80)	41-4152-1,2	(May-80)
		39-3960-7,8	(May-80)	41-4152-3,4	(May-80)
37-3715-1,2	(May-80)	39-3960-9,10	(May-80)	41-4152-5,6	(May-80)
37-3715-3,4	(May-80)	39-3960-11,12	(May-80)	41-4160-1,2	(May-80)
37-3715-5,6	(May-80)	39-3960-13,14	(May-80)	41-4199-1,2	(May-80)
37-3715-7,8	(May-80)	39-3960-15,16	(May-80)	41-4199-3,4	(May-80)
37-3715-9,10	(May-80)	39-3960-17,18	(May-80)	41-4199-5,6	(May-80)
37-3740-1,2	(May-80)	39-3960-19,20	(May-80)	41-4199-7,8	(May-80)
37-3740-3,4	(May-80)	39-3960-21,22	(May-80)	41-4199-9,10	(May-80)
37-3740-5,6	(May-80)	39-3960-23,24	(May-80)	41-4199-11,12	(May-80)
37-3740-7,8	(May-80)	39-3960-25,26	(May-80)		
37-3740-9,10	(May-80)	39-3960-27,28	(May-80)	43-4315-1,2	(May-80)
37-3760-1,2	(May-80)	39-3960-29,30	(May-80)	43-4315-3,4	(May-80)
37-3760-3,4	(May-80)	39-3960-31,32	(May-80)	43-4350-1,2	(May-80)
37-3760-5,6	(May-80)	39-3960-33,34	(May-80)	43-4350-3,4	(May-80)
37-3760-7,8	(May-80)	39-3999-1,2	(May-80)	43-4350-5,6	(May-80)
37-3760-9,10	(May-80)	39-3999-3,4	(May-80)	43-4350-7,8	(May-80)
37-3760-11,12	(May-80)	39-3999-5,6	(May-80)	43-4350-9,10	(May-80)
37-3760-13,14	(May-80)	39-3999-7,8	(May-80)	43-4350-11,12	(May-80)
37-3799-1,2	(May-80)			43-4360-1,2	(May-80)
37-3799-3,4	(May-80)	41-4125-1,2	(May-80)	43-4360-3,4	(May-80)
37-3799-5,6	(May-80)	41-4125-3,4	(May-80)	43-4360-5,6	(May-80)
		41-4125-5,6	(May-80)	43-4360-7,8	(May-80)
38-3803-1,2	(May-80)	41-4125-7,8	(May-80)	43-4360-9,10	(May-80)
38-3803-3,4	(May-80)	41-4125-9,10	(May-80)	43-4360-11,12	(May-80)
38-3803-5,6	(May-80)	41-4125-11,12	(May-80)	43-4360-13,14	(May-80)
38-3813-1,2	(May-80)	41-4141-1,2	(May-80)	43-4399-1,2	(May-80)
38-3860-1,2	(May-80)	41-4141-3,4	(May-80)	43-4399-3,4	(May-80)
38-3860-3,4	(May-80)	41-4141-5,6	(May-80)		
38-3860-5,6	(May-80)	41-4151-1,2	(May-80)		
38-3860-7,8	(May-80)	41-4151-3,4	(May-80)		
38-3899-1,2	(May-80)	41-4151-5,6	(May-80)		
38-3899-3,4	(May-80)				

COMPLETE PAGE LISTING—Continued

44-4401-1,2	(May-80)	90-9015-21,22	(May-80)	90-9020-15,16	(May-80)
44-4401-3,4	(May-80)	90-9015-23,24	(May-80)	90-9020-17,18	(May-80)
44-4401-5,6	(May-80)	90-9015-25,26	(May-80)	90-9020-19,20	(May-80)
44-4401-7,8	(May-80)	90-9015-27,28	(May-80)	90-9020-21,22	(May-80)
44-4440-1,2	(May-80)	90-9015-29,30	(May-80)	90-9020-23,24	(May-80)
44-4440-3,4	(May-80)	90-9015-31,32	(May-80)	90-9020-25,26	(May-80)
44-4460-1,2	(May-80)	90-9015-33,34	(May-80)	90-9020-27,28	(May-80)
44-4460-3,4	(May-80)	90-9015-35,36	(May-80)	90-9020-29,30	(May-80)
44-4460-5,6	(May-80)	90-9015-37,38	(May-80)	90-9020-31,32	(May-80)
44-4460-7,8	(May-80)	90-9015-39,40	(May-80)	90-9025-1,2	(May-80)
44-4460-9,10	(May-80)	90-9015-41,42	(May-80)	90-9025-3,4	(May-80)
44-4460-11,12	(May-80)	90-9015-43,44	(May-80)	90-9025-5,6	(May-80)
44-4460-13,14	(May-80)	90-9015-45,46	(May-80)	90-9025-7,8	(May-80)
44-4460-15,16	(May-80)	90-9015-47,48	(May-80)	90-9025-9,10	(May-80)
44-4460-17,18	(May-80)	90-9015-49,50	(May-80)	90-9025-11,12	(May-80)
44-4460-19,20	(May-80)	90-9015A-1,2	(May-80)	90-9025-13,14	(May-80)
44-4460-21,22	(May-80)	90-9015A-3,4	(May-80)	90-9025-15,16	(May-80)
44-4460-23,24	(May-80)	90-9015A-5,6	(May-80)	90-9025-17,18	(May-80)
44-4499-1,2	(May-80)	90-9015A-7,8	(May-80)	90-9025-19,20	(May-80)
44-4499-3,4	(May-80)	90-9015A-9,10	(May-80)	90-9025-21,22	(May-80)
44-4499-5,6	(May-80)	90-9015A-11,12	(May-80)	90-9025-23,24	(May-80)
		90-9015A-13,14	(May-80)	90-9025-25,26	(May-80)
90-9005-1,2	(May-80)	90-9015A-15,16	(May-80)	90-9025-27,28	(May-80)
90-9005-3,4	(May-80)	90-9015A-17,18	(May-80)	90-9025-29,30	(May-80)
90-9005-5,6	(May-80)	90-9015A-19,20	(May-80)	90-9025-31,32	(May-80)
90-9010-1,2	(May-80)	90-9015A-21,22	(May-80)	90-9025-33,34	(May-80)
90-9010-3,4	(May-80)	90-9015A-23,24	(May-80)	90-9025-35,36	(May-80)
90-9010-5,6	(May-80)	90-9015A-25,26	(May-80)	90-9025-37,38	(May-80)
90-9010-7,8	(May-80)	90-9015A-27,28	(May-80)	90-9025-39,40	(May-80)
90-9010-9,10	(May-80)	90-9015A-29,30	(May-80)	90-9025-41,42	(May-80)
90-9010-11,12	(May-80)	90-9015A-31,32	(May-80)	90-9025-43,44	(May-80)
90-9010-13,14	(May-80)	90-9015A-33,34	(May-80)	90-9025-45,46	(May-80)
90-9010-15,16	(May-80)	90-9015A-35,36	(May-80)	90-9025-47,48	(May-80)
90-9010-17,18	(May-80)	90-9015A-37,38	(May-80)	90-9025-49,50	(May-80)
90-9010-19,20	(May-80)	90-9015A-39,40	(May-80)	90-9025-51,52	(May-80)
90-9015-1,2	(May-80)	90-9015A-41,42	(May-80)	90-9025-53,54	(May-80)
90-9015-3,4	(May-80)	90-9015A-43,44	(May-80)	90-9025-55,56	(May-80)
90-9015-5,6	(May-80)	90-9015A-45,46	(May-80)	90-9025-57,58	(May-80)
90-9015-7,8	(May-80)	90-9020-1,2	(May-80)	90-9025-59,60	(May-80)
90-9015-9,10	(May-80)	90-9020-3,4	(May-80)	90-9025-61,62	(May-80)
90-9015-11,12	(May-80)	90-9020-5,6	(May-80)	90-9025-63,64	(May-80)
90-9015-13,14	(May-80)	90-9020-7,8	(May-80)	90-9025-65,66	(May-80)
90-9015-15,16	(May-80)	90-9020-9,10	(May-80)	90-9025-67,68	(May-80)
90-9015-17,18	(May-80)	90-9020-11,12	(May-80)	90-9025-69,70	(May-80)
90-9015-19,20	(May-80)	90-9020-13,14	(May-80)	90-9025-71,72	(May-80)

COMPLETE PAGE LISTING—Continued

90-9025-73,74	(May-80)	90-9031-1,2	(May-80)	90-9035-1,2	(May-80)
90-9025-75,76	(May-80)	90-9031-3,4	(May-80)	90-9035-3,4	(May-80)
90-9025-77,78	(May-80)	90-9031-5,6	(May-80)	90-9035-5,6	(May-80)
90-9025-79,80	(May-80)	90-9031-7,8	(May-80)	90-9035-7,8	(May-80)
90-9025-81,82	(May-80)	90-9031-9,10	(May-80)	90-9035-9,10	(May-80)
90-9025-83,84	(May-80)	90-9031-11,12	(May-80)	90-9035-11,12	(May-80)
90-9025-85,86	(May-80)	90-9031-13,14	(May-80)	90-9035-13,14	(May-80)
90-9025-87,88	(May-80)	90-9031-15,16	(May-80)	90-9035-15,16	(May-80)
90-9025-89,90	(May-80)	90-9031-17,18	(May-80)	90-9035-17,18	(May-80)
90-9025-91,92	(May-80)	90-9031-19,20	(May-80)	90-9035-19,20	(May-80)
90-9025-93,94	(May-80)	90-9031-21,22	(May-80)	90-9035-21,22	(May-80)
90-9025-95,96	(May-80)	90-9031-23,24	(May-80)	90-9035-23,24	(May-80)
90-9025-97,98	(May-80)	90-9031-25,26	(May-80)	90-9035-25,26	(May-80)
90-9025-99,100	(May-80)			90-9035-27,28	(May-80)
90-9025-101,102	(May-80)			90-9035-29,30	(May-80)
90-9025-103,104	(May-80)			90-9035-31,32	(May-80)
90-9025-105,106	(May-80)				
90-9025-107,108	(May-80)				
90-9030-1,2	(May-80)				

Group II INTRODUCTION AND SAFETY INFORMATION

INTRODUCTION

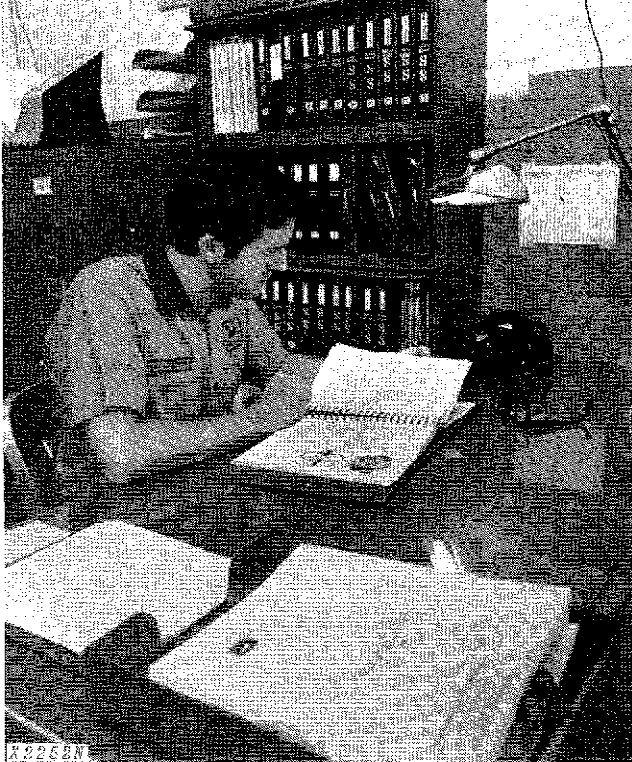

Use FOS Manuals for Reference



Use Technical Manuals for Actual Service

This technical manual is part of a twin concept of service:

The two kinds of manuals work as a team to give you both the general background and technical details of shop service.

■FOS Manuals—for reference

Fundamentals of Service (FOS) Manuals cover basic theory of operation, *fundamentals* of trouble shooting, *general* maintenance, and *basic* types of failures and their causes. FOS Manuals are for training new personnel and for reference by experienced service technicians.



When a service technician should refer to a FOS Manual for more information, a FOS symbol like the one at left is used in the TM to identify reference.

■Technical Manuals—for actual service

Technical Manuals are *concise* service guides for a *specific* machine. Technical manuals are on-the-job guides containing only vital information needed by an experienced service technician.

This technical manual was planned and written for you—an experienced service technician. Keep it in a permanent binder in the shop where it is handy. Refer to it whenever in doubt about correct service procedures or specifications.

Some features of this manual:

- Inside front cover - "Table of Contents".
- Section I - Contents, safety information, general specifications and general services.
- Sections 1 through 44 - Removal, repair, testing (components removed), installation, and adjustment.
- Section 90 - Detailed explanation of system operation, diagnosis, visual inspection, testing, and adjustments.
- Specifications grouped and illustrated at the end of each section.

MAINTENANCE WITHOUT ACCIDENT WORK SAFELY



T27993N



This safety alert symbol is used for important safety messages. When you see this symbol, the possibility of personal injury exists if safety message is not followed.

EVERY EMPLOYER HAS A SAFETY PROGRAM. KNOW WHAT IT IS!

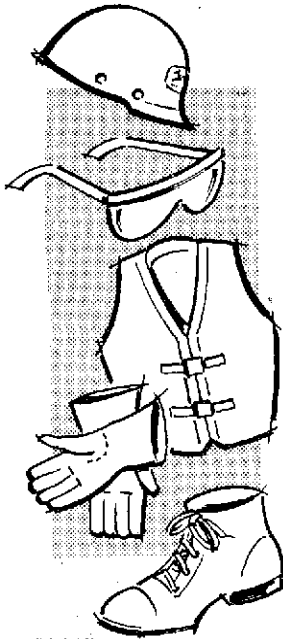

T27501N

Consult your shop supervisor for specific instructions on a job, and the safety equipment required.

For instance, you may need: Hard hat, safety shoes, safety goggles, heavy gloves, reflector vests, ear protectors, respirators.

RIGHT

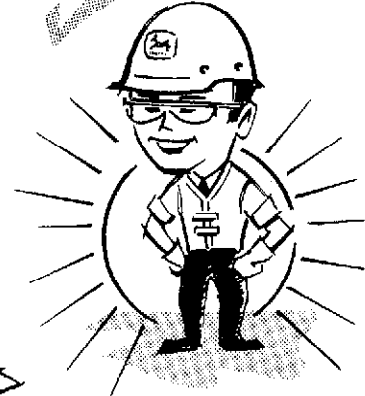

WRONG

T27502N

ALWAYS AVOID loose clothing or any accessory—flopping cuffs, dangling neckties and scarves, or rings and wrist watches—that can catch in moving parts and put you out of work.

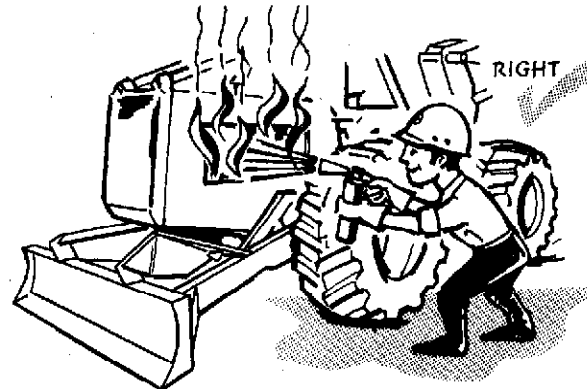

T50632N

BE ALERT!

Plan ahead—work safely—avoid accidental damage and injury. If a careless moment does cause an accident or fire, react quickly with the tools and skills at hand—know how to use a first aid kit and a fire extinguisher—and where to get aid and assistance. In an emergency, split-second action is the key to safety.

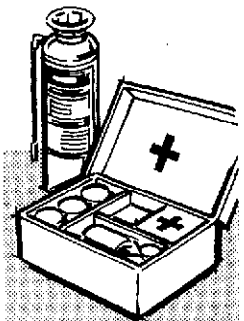

T27504N

MAINTENANCE WITHOUT ACCIDENT

Specific safety procedures should always be observed, whether servicing or making repairs on tree harvester or feller-buncher. Remembering these—in time!—can prevent an injury...or save your life....

AVOID FIRE HAZARDS—

Fuel Is Dangerous!

- Don't smoke while refueling.
- Don't smoke while handling highly flammable material.
- Engine should be shut off when refueling.
- Use care in refueling if engine is hot.

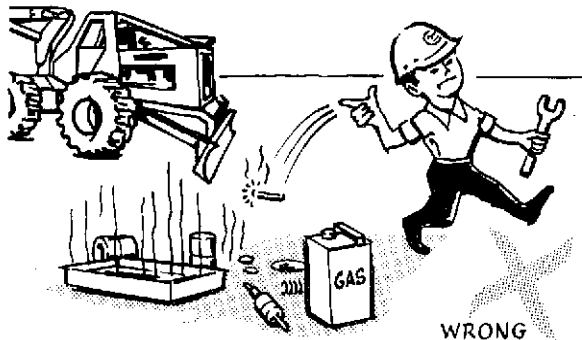

T50633N

Don't use open pans of gasoline or diesel fuel for cleaning parts. Good commercial, nonflammable solvents are preferred.

Battery Gas Is Highly Flammable!

Provide adequate ventilation when charging batteries.

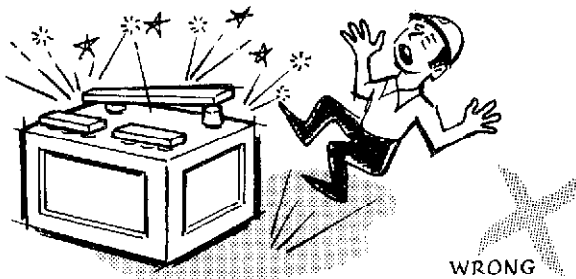

T27506N

- Don't check battery charge by placing metal objects across the posts.
- Don't allow sparks or open flame near batteries.
- Don't smoke near battery.

Flame Is Not a Flashlight!

- Never check fuel, battery electrolyte or coolant levels with an open flame.
- Never use an open flame to look for leaks anywhere on equipment.

Know Where Fire Extinguishers Are Kept!

UNDER ALL MAINTENANCE CONDITIONS—

Do not perform any work on the tree harvester or feller-buncher unless authorized to do so. Then be sure you understand the services required. Follow recommended procedures.

Never service equipment while it is being operated.

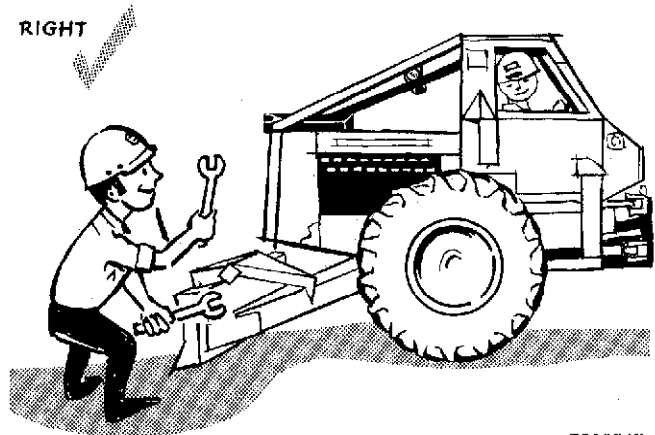

T50634N

Avoid working on equipment with the engine running. If it is necessary to make checks with the engine running, **ALWAYS USE TWO SERVICE TECHNICIANS**—one, the operator, at the controls, the other checking in view of the operator. Also, put the transmission in neutral, set the brake, and apply any safety locks provided. **KEEP HANDS AWAY FROM MOVING PARTS.**

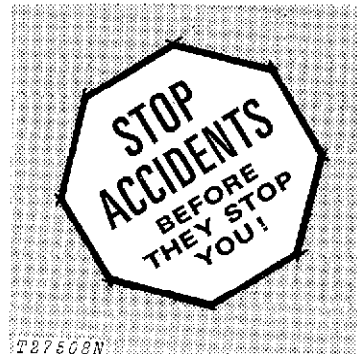

T27506N

MAINTENANCE WITHOUT ACCIDENT

Before servicing, adjusting, or repairing tree support blade or tree shear—**LOWER** equipment to ground—or, if necessary to raise them for access to certain parts, **SECURELY SUPPORT** by external means. **DO NOT** rely on controls to support or position equipment for maintenance. The tree shear must be lowered to ground or hung on transport peg to prevent mast rotation when engine is shut off.

Never allow **ANYONE** to walk under equipment that is raised and not properly blocked.

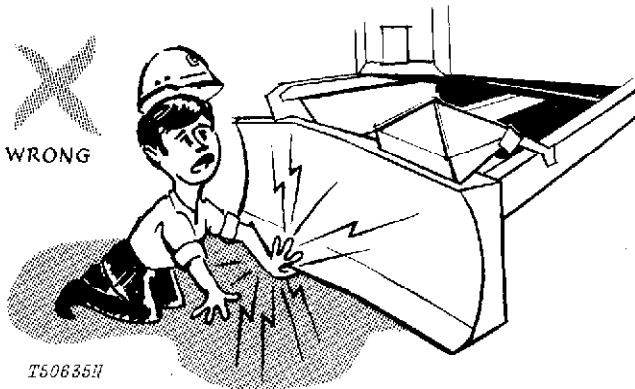

Avoid working directly under raised and blocked equipment unless absolutely necessary.

If tree harvester or feller-buncher is on an incline, block it securely.

Use hoisting equipment for lifting heavy parts. **TAKE CARE! WATCH OUT FOR OTHER PEOPLE IN THE VICINITY.**

Use extreme caution in removing radiator caps, drain plugs, grease fittings, or hydraulic pressure caps.

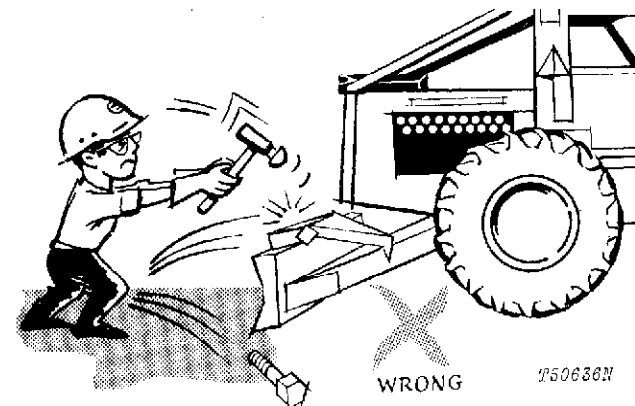

Wear safety glasses when drilling, grinding, or hammering metal.

Make sure maintenance area is adequately vented.

Keep maintenance area **CLEAN AND DRY**. Oily and wet floors are slippery; greasy rags are a fire hazard; wet spots are dangerous when working with electrical equipment.

Store starting aids in a cool and well-ventilated place, out of the reach of unauthorized personnel.

SERVICING PRECAUTIONS

Stop engine before cleaning or lubricating the tree harvester or feller-buncher.

Lower tree support blade and shear to the ground carefully.

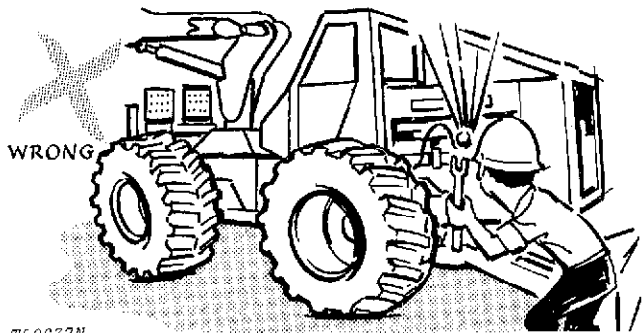

Engine coolant gets hot! Don't remove radiator cap until coolant temperature is below boiling point. Then turn cap slightly to relieve pressure before removing.

Exhaust gases are dangerous! Periodically check exhaust system for excessive leakage.

Don't forget a hydraulic system may be pressurized! To relieve system pressure, stop engine, lower tree support blade and shear and operate tree support blade and boom controls until system fails to respond.

When checking hydraulic pressure, be sure to use the correct test gauge for the pressure in particular circuit.

The tree harvester or feller-buncher is equipped with brake and hydraulic system accumulators. To discharge brake accumulator depress brake pedal (with engine off) until brake pedal bottoms out and no resistance is felt. To discharge hydraulic system accumulator, turn steering wheel back and forth (with engine off) until no frame movement is observed.

MAINTENANCE WITHOUT ACCIDENT

When preparing engine for storage, remember that inhibitor is volatile and therefore dangerous. Seal and tape openings after adding inhibitor. Keep container tightly closed when not in use.

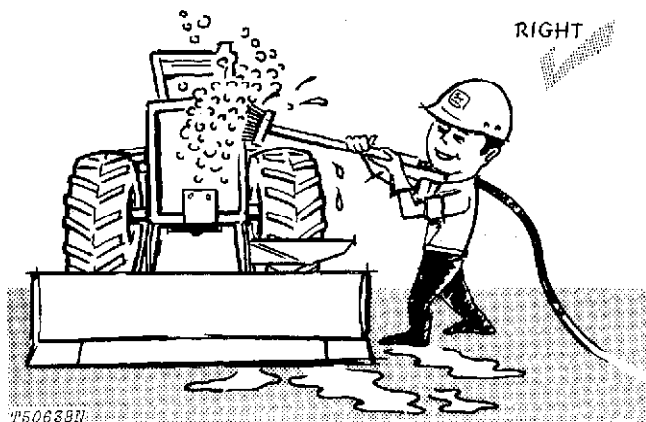

Keep ALL components free of dirt and oil. This attention will minimize fire hazards and facilitate spotting of loose or defective parts.

ADJUSTING PRECAUTIONS

... for Operating Adjustments

Keep clutch and brake control units properly adjusted at all times. Before making adjustments, stop engine.

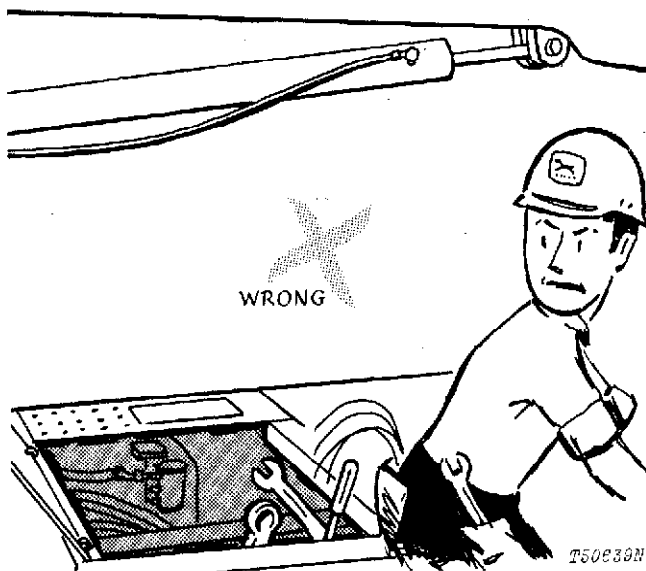

Before removing any housing covers, stop engine. Take all objects from your pockets which could fall into opened housings. Don't let wrenches fall into opened housings.

... for Maintenance Adjustments

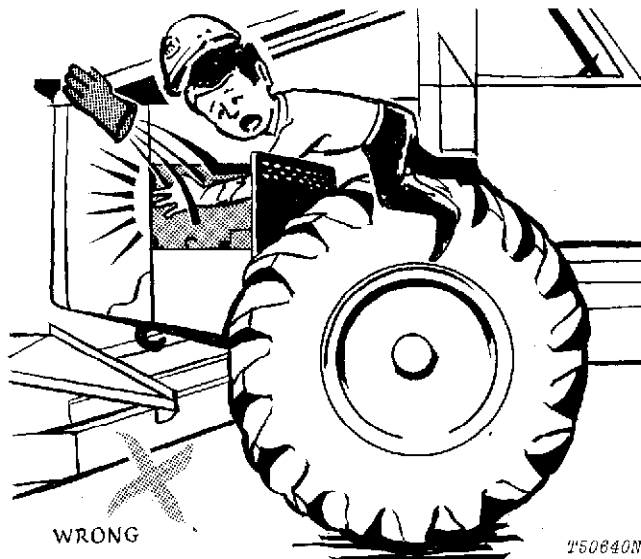

Don't adjust fuel system while machine is in motion.

MAINTENANCE WITHOUT ACCIDENT

PRECAUTIONS DURING REPAIR

Before working on engine fuel system—close fuel shutoff valve.

Before working on hydraulic system—make sure engine is not running and system pressure is relieved by working control levers in all directions with engine shut off.

Before repairing electrical system, or performing a major overhaul, make sure batteries are disconnected.

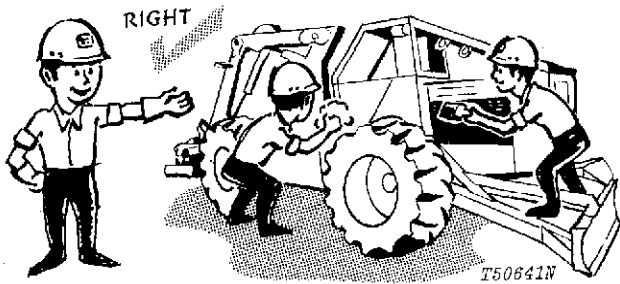

Keep ALL components free of dirt and oil. This attention will minimize fire hazards and aid in locating loose or defective parts.

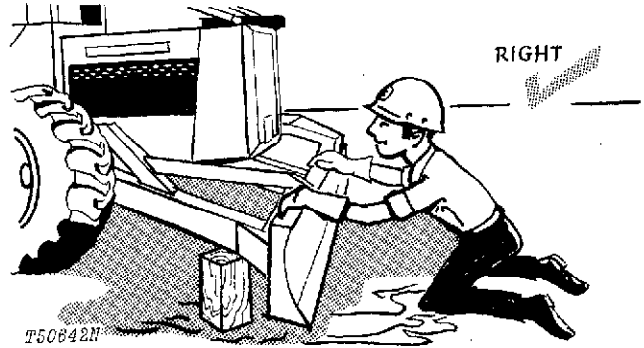

When changing cutting edges on tree support blade, stop engine and securely block blade.

Never let your bare hands come in contact with sharp edges. WEAR GLOVES.



MAINTENANCE WITHOUT ACCIDENT

KNOW EQUIPMENT IS READY!

Check guards, safety bars—all protective devices installed on tree harvester or feller-buncher. Every one should be in place and secure.

CHECK IT OUT!

- GUARDS
- SHIELDS
- PROTECTIVE DEVICES
- ROLL-OVER PROTECTIVE STRUCTURES
- SEAT BELTS
- FIRE EXTINGUISHER
- FIRE SUPPRESSION SYSTEM, ETC.

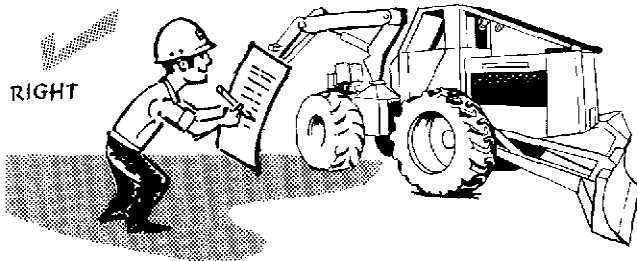

T50643N

Carefully inspect equipment for visual defects—leaks in fuel, lubrication, and hydraulic systems.

Escaping fluid under pressure can have sufficient force to penetrate the skin, causing serious personal injury. Before disconnecting lines, be sure to relieve all pressure. Before applying pressure to the system, be sure all connections are tight and that lines, pipes and hoses are not damaged. Fluid escaping from a very small hole can be almost invisible. Use a piece of cardboard or wood, rather than hands, to search for suspected leaks.

If injured by escaping fluid, see a doctor at once. Serious infection or reaction can develop if proper medical treatment is not administered immediately.

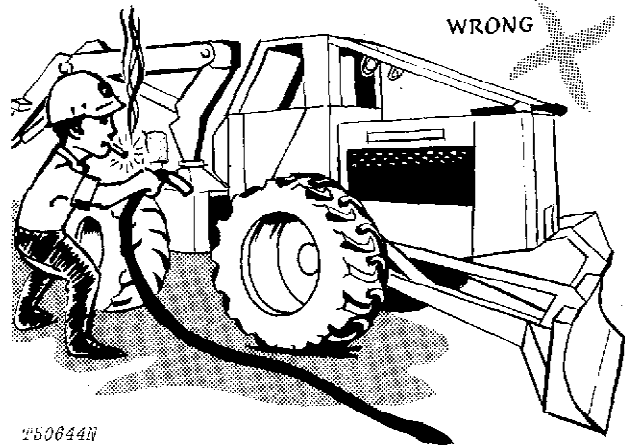

T50644N

Check levels of fuel, coolant, hydraulic fluid, and lubricating oil. If fuel must be added—**FIRST, PUT OUT THAT CIGARET.**

Check and secure all caps and filler plugs for fuel, oils, radiator, etc.

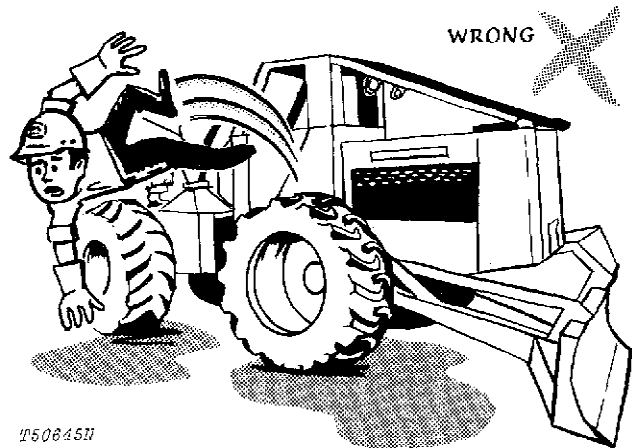

T50645N

Be sure to clean any oil, grease or mud accumulation from floor of operator's compartment, stepping points, and grab rails to minimize the danger of slipping.

In freezing weather beware of snow or ice deposits on stepping points, grab rails, and floor.

Remove loose bolts, tools, or other objects from floor of operator's compartment.

Although it is impractical to try to cover every possible maintenance situation, safety precautions recommended here should serve to develop and promote safe maintenance procedures.

The information contained in this technical manual is not intended to replace safety codes, insurance requirements, federal, state, and local laws, rules and regulations. In particular, your service area or jobsite activities may be subject to state safety rules and/or federal regulations under the Occupational Safety and Health Act (OSHA). Familiarize yourself with all regulations applicable to your situation in order to avoid possible safety violations.

Illustrations and copy reproduced in part by permission of Construction Industry Manufacturers' Association (CIMA).

Group III GENERAL SPECIFICATIONS

TREE HARVESTER

(Specifications and design subject to change without notice. Wherever applicable, specifications are in accordance with ICED and SAE Standards. Except where otherwise noted, these specifications are based on a unit equipped with 30.5-32, 12 ply rating logging tires and standard equipment.)

Power (at 2400 engine rpm): **SAE** **DIN**
Gross167 hp (124.6 kW)
Net152 hp (113.4 kW) 154 PS

Net engine flywheel power is for an engine equipped with fan, air cleaner, water pump, lubricating oil pump, fuel pump, alternator, and muffler. The gross engine power is without fan. Flywheel power ratings are under SAE standard conditions of 500 ft. altitude and 85°F temperature, and DIN 70 020 conditions (non-corrected). No derating is required up to 10,000 ft. (3000 m) altitude.

Engine: John Deere diesel, vertical 6-cylinder, valve-in-head, 4-stroke cycle—turbocharged and inter-cooled.

Bore and stroke4.56×4.75 in. (116×121 mm)
Piston displacement 466 cu. in. (7.638 L)
Compression ratio 15.5 to 1
Maximum torque

@ 1200 rpm 507 lb-ft (687 N·m) (70.1 kg·m)
NACC or AMA (U.S. Tax) horsepower 49.9
Lubrication Pressure system w/full-flow filter
Cooling . Pressurized w/thermostat and fixed bypass
Fan Suction
Air cleaner w/restriction indicator Dry
Electrical system 12 volt w/alternator
Batteries (2) Reserve capacity: 360 minutes

Differentials:

Front and rear . . . Full differentials with hydraulic lock

Engine Clutch Disconnect:

Hand-operated, spring-loaded, dry-disk. Single plate, 12.88 in. (327 mm).

Transmission:

Power Shift with planetary gears, hydraulically actuated wet-disk clutches and brakes; provides 8 speeds forward—4 reverse. Controlled by single lever. Pressurized lubrication.

Travel Speeds (2200 engine rpm, no tire slip):

Forward: 1.63 to 18.40 mph (2.62 to 29.61 km/h)
Reverse: 2.00 to 5.79 mph (3.22 to 9.32 km/h)

Drive Axles:

Four-wheel drive with inboard planetary gears on all axles. Rear axle oscillates 15 degrees above and below horizontal. 24.9 in. (632 mm) total travel at tire center line at narrowest tread. Oscillation is hydraulically locked when transmission is in neutral.

Brakes:

Service...Hydraulic power-actuated, pedal-controlled, wet-disk on 4 wheels.
Harvesting.....Manually locked service brakes.
Parking.....Foot-operated mechanical disk.

Power Steering:

Articulated frame hydraulically actuated by dual cylinders.
Turning radius..... 18 ft. 10.7 in. (5.75 m)
Curb clearance circle
(w/o braking) 40 ft. 5.5 in. (12.33 m)
Steering wheel rotation, max. left to
max. right 3 turns

Hydraulic System:

Closed-center, constant pressure. Variable-displacement pump driven from crankshaft...72 gpm (4.54 L/s), 2000 psi (13 790 kPa) (140.6 kg/cm²) @ 2200 engine rpm. Oil cooler included in system. Filtration: 10 micron.

Tires:

30.5-32, 12 ply rating, logging, steel-ply, LS-2
30.5-32, 12 ply rating, logging, steel-ply, dual bead, LS-2
30.5-32, 16 ply rating, logging, steel-ply, dual bead, LS-2

Ground pressure (4 in. [102 mm]

penetration)..... 10.7 psi
(73.8 kPa) (0.75 kg/cm²)

Cab:

ROPS and FOPS constructed. Steel with urethane sound-proofing. Windows are impact-resistant polycarbonate. Windshield has mar-resistant coating. Cab tilts forward 15 degrees for servicing.

OPERATING INFORMATION

Boom:

Lift capacity at maximum reach . . . 3200 lb. (1451 kg)
 Swing speed 30 deg. per second
 Boom swing torque . . . 24,358 lb-ft (33 025 N-m) (3368 kg-m) at 2250 psi (15 514 kPa) (158.2 kg/cm²)
 Maximum cutting radius 17 ft. 6 in. (5.33 m)
 Minimum cutting radius 10 ft. (3 m)
 Total cutting area 625 sq. ft. (58.1 m²)
 Cutting arc 270 deg.

Hydraulic

Cylinders:	Bore	Rod	Stroke
Main boom	6.25 in. (158.5 mm)	3.25 in. (82.5 mm)	39.08 in. (992.5 mm)
Secondary boom	4.50 in. (114.5 mm)	2.50 in. (63.5 mm)	32.10 in. (815.5 mm)

Delimber:

Controls . . . Automatic or manually selected control of delimiting functions
 Feed roll drum diameter 18 in. (457 mm)
 Spikes per roll 150
 Roll speed (forward and reverse) 400 ft/min (122 m/min)
 Feed force 14,000 lb. (62.75 kN) (6350 kg)
 Knives (replaceable) 2 movable; 1 stationary
 Automatic topping at 2.5 in. (64 mm) stem diameter

Feed Roll:

Transmisson . . Live mechanical drive; hydraulically-actuated clutch and brakes; mechanically-synchronized closure
 Maximum input speed 928 rpm
 Reduction ratio 10.94 to 1

Hydraulic

Cylinders:	Bore	Rod	Stroke
Feed roll	2.50 in. (63.5 mm)	1.25 in. (32 mm)	10.00 in. (254 mm)
Delimiting knife, right	1.87 in. (47.6 mm)	1.00 in. (25.4 mm)	7.76 in. (197 mm)
Delimiting knife, left	1.87 in. (47.6 mm)	1.00 in. (25.4 mm)	7.76 in. (197 mm)

Shear:

Maximum tree butt diameter 18 in. (46 cm)
 Blade thickness 0.625 in. (16 mm)

Hydraulic

Cylinders:	Bore	Rod	Stroke
Shear tilt	4.50 in. (114.5 mm)	2.25 in. (57.2 mm)	31.26 in. (794 mm)
Grapple clamps (2)	4.00 in. (101.5 mm)	1.75 in. (44.5 mm)	5.51 in. (140 mm)
Shear (double acting)	6.50 in. (165 mm)	2.50 in. (63.5 mm)	19.88 in. (505 mm)

Capacities:	U.S.	Imp.	Liters
Fuel tank	50 gal.	41.7 gal.	189.2
Cooling system	9 gal.	7.5 gal.	34.1
Engine lubrication, including filter	20 qt.	16.7 qt.	18.9
Transmission	12.2 gal.	10.2 gal.	46.2
Hydraulic-reservoir	24 gal.	20 gal.	90.8
Feed roll drive housing (each)	4 qt.	3.3 qt.	3.8
Delimber gearboxes (each)	4 qt.	3.3 qt.	3.8
Delimber drive transmission	4 qt.	3.3 qt.	3.8
Front differential	26 qt.	21.7 qt.	24.6
Rear differential	26 qt.	21.7 qt.	24.6
SAE Operating Weight	41,400 lb. (18 779 kg)		

Additional Standard Equipment:

- Bottom guards
 - Cab with ROPS, heater, air conditioner, and protective windows
 - Cigar lighter
 - Cushion seat with position adjustment and seat belt
 - Engine side shields
 - Cold weather starting aid
 - Fire extinguisher
 - Gauges:
 - Electric hour meter
 - Engine coolant temperature
 - Engine oil pressure
 - Fuel
 - Voltmeter
 - Hand and foot throttle
 - Heavy-duty starter
 - Frame locking bar
 - Horn
 - Hydraulic oil warmup switch
 - Hydraulic pump discharge filter
 - Indicator lights:
 - Hydraulic oil sump level
 - Hydraulic oil temperature
 - Transmission oil temperature
 - Transmission oil pressure
 - Key switch with pushbutton safety start
 - Lights
 - Muffler with rain deflector and protective guard
 - Parking brake
 - Transistorized voltage regulator
 - Vandal protection
 - Windshield wiper and washer
- Special Equipment:**
- 3 in. (76 mm) seat belt
 - Automatic fire suppression system
 - Multi-stem shear
 - Radio
 - Rear tree accumulator
 - Steering accumulator

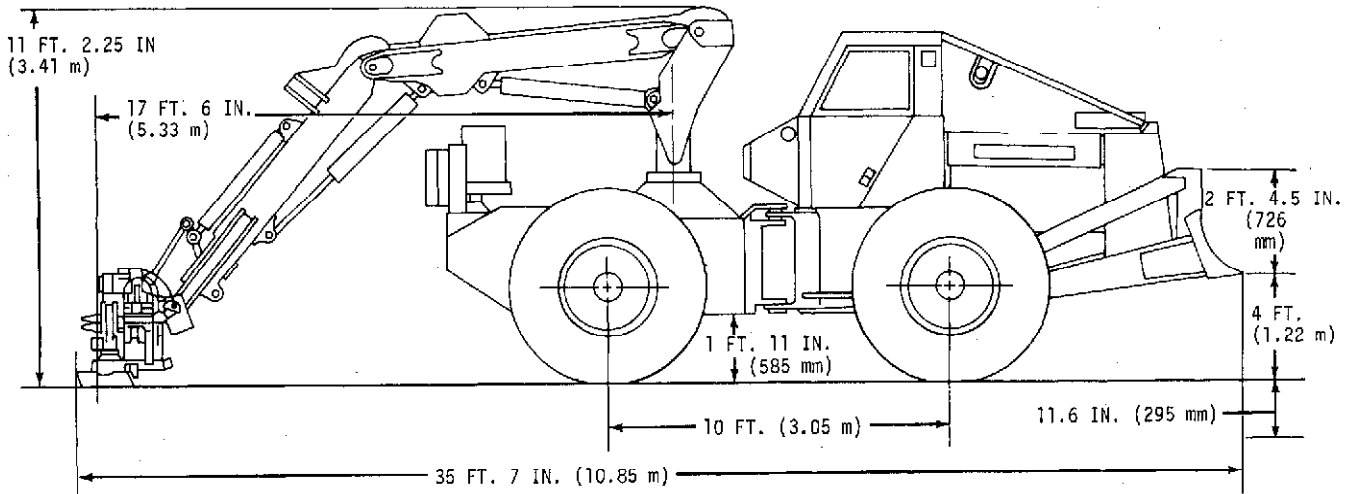

T49905N

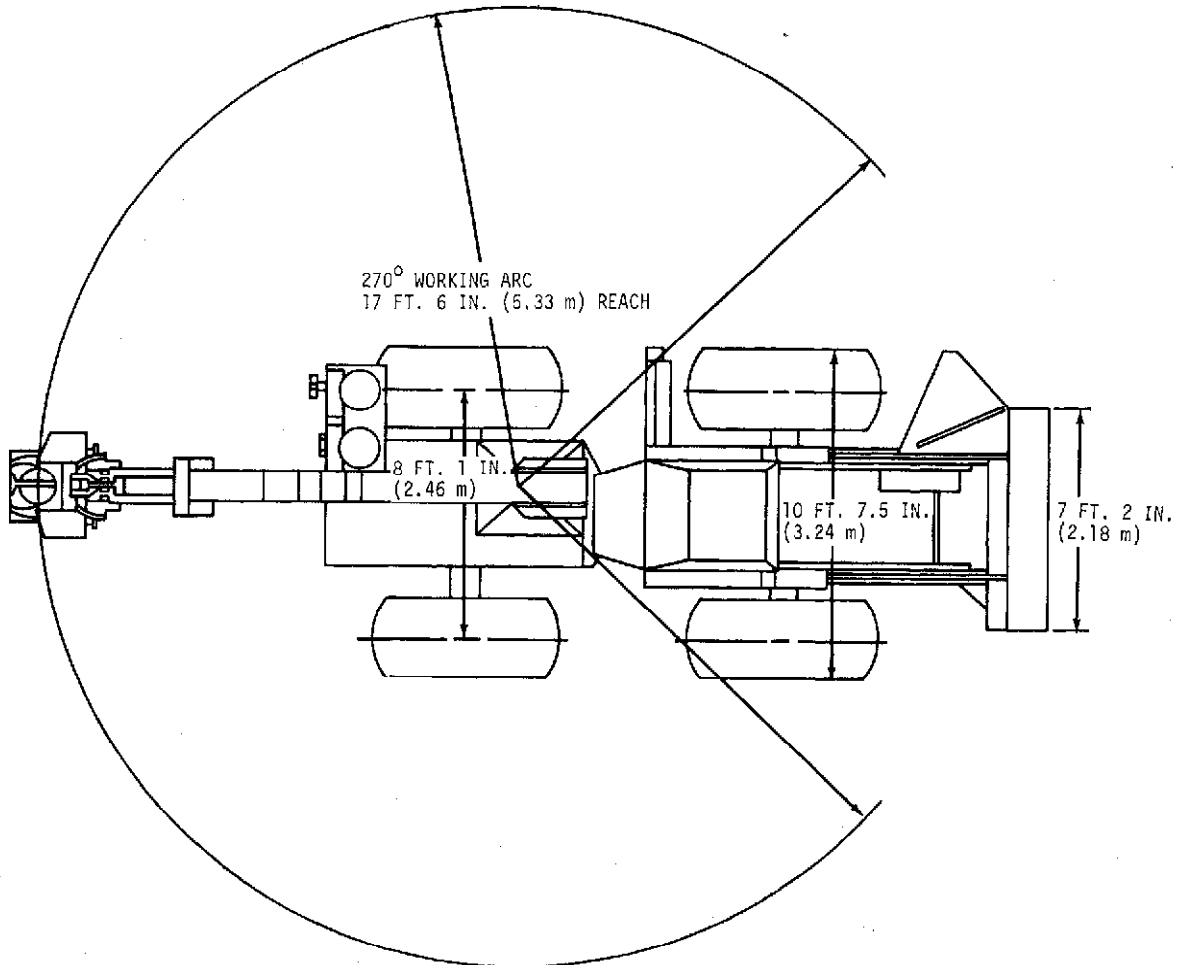

T50646N

FELLER-BUNCHER

(Specifications and design subject to change without notice. Wherever applicable, specifications are in accordance with ICED and SAE Standards. Except where otherwise noted, these specifications are based on a unit equipped with 30.5-32, 12 ply rating logging tires and standard equipment.)

Power (at 2200 engine rpm):	SAE	DIN
Gross	167 hp (124.6 kW)	
Net	152 hp (113.3 kW)	154 PS

Net engine flywheel power is for an engine equipped with fan, air cleaner, water pump, lubricating oil pump, fuel pump, alternator, and muffler. The gross engine power is without fan. Flywheel power ratings are under SAE standard conditions of 500 ft. altitude and 85°F temperature, and DIN 70 020 conditions (non-corrected). No derating is required up to 10,000 ft. (3000 m) altitude.

Engine: John Deere diesel, vertical 6-cylinder, valve-in-head, 4-stroke cycle—turbocharged and inter-cooled.

Bore and stroke 4.56×4.75 in. (116×121 mm)
Piston displacement 466 cu. in. (7.638 L)
Compression ratio 15.5 to 1
Maximum torque

@ 1200 rpm 507 lb-ft (687 N·m) (70.1 kg-m)
NACC or AMA (U.S. Tax) horsepower 49.9
Lubrication Pressure system w/full-flow filter
Cooling . Pressurized w/thermostat and fixed bypass
Fan Suction
Air cleaner w/restriction indicator Dry
Electrical system 12 volt w/alternator
Batteries (2) Reserve capacity: 360 minutes

Differentials:

Front and rear . . Full differentials with hydraulic lock

Engine Clutch Disconnect:

Hand-operated, spring-loaded, dry-disk. Single plate, 12.88 in. (327 mm).

Transmission:

Power Shift with planetary gears, hydraulically actuated wet-disk clutches and brakes; provides 8 speeds forward—4 reverse. Controlled by single lever. Pressurized lubrication.

Travel Speeds (2200 engine rpm, no tire slip):

Forward: 1.63 to 18.40 mph (2.62 to 29.61 km/h)
Reverse: 2.00 to 5.79 mph (3.22 to 9.32 km/h)

Drive Axles:

Four-wheel drive with inboard planetary gears on all axles. Rear axle oscillates 15 degrees above and below horizontal. 24.9 in. (632 mm) total travel at tire center line at narrowest tread. Oscillation is hydraulically locked when transmission is in neutral.

Brakes:

Service . . . Hydraulic power-actuated, pedal-controlled, wet-disk on 4 wheels.
Operating Manually locked service brakes.
Parking Foot-operated mechanical disk.

Power Steering:

Articulated frame hydraulically actuated by dual cylinders.
Turning radius 18 ft. 10.7 in. (5.75 m)
Curb clearance circle
(w/o braking) 40 ft. 5.5 in. (12.33 m)
Steering wheel rotation, max. left to
max. right 3 turns

Hydraulic System:

Closed-center, constant pressure. Variable-displacement pump driven from crankshaft . . . 72 gpm (4.54 L/s), 2000 psi (13 790 kPa) (140.6 kg/cm²) @ 2200 engine rpm. Oil cooler included in system. Filtration: 10 micron.

Tires:

30.5-32, 12 ply rating, logging, steel-ply, LS-2
30.5-32, 12 ply rating, logging, steel-ply, dual bead, LS-2
30.5-32, 16 ply rating, logging, steel-ply, dual bead, LS-2

Ground pressure (4 in. [102 mm] penetration) 9.0 psi (62 kPa) (0.63 kg/cm²)

Cab:

ROPS and FOPS constructed. Steel with urethane sound-proofing. Windows are impact-resistant polycarbonate. Windshield has mar-resistant coating. Cab tilts forward 15 degrees for servicing.

OPERATING INFORMATION

Boom:

Lift capacity at maximum reach . . . 3200 lb. (1451 kg)
 Swing speed 30 deg. per second
 Boom swing torque . . . 24,358 lb-ft (33 025 N·m) (3368
 kg-m) at 2250 psi (15 514 kPa) (158.2 kg/cm²)
 Maximum cutting radius 17 ft. 6 in. (5.33 m)
 Minimum cutting radius 10 ft. (3 m)
 Total cutting area 625 sq. ft. (58.1 m²)
 Cutting arc 270 deg.

Hydraulic

Cylinders:	Bore	Rod	Stroke
Main boom . . .	6.25 in. (158.5 mm)	3.25 in. (82.5 mm)	39.08 in. (992.5 mm)
Secondary boom	4.50 in. (114.5 mm)	2.50 in. (63.5 mm)	32.10 in. (815.5 mm)

Shear:

Maximum tree butt diameter 18 in. (46 cm)
 Blade thickness 0.625 in. (16 mm)

Hydraulic

Cylinders:	Bore	Rod	Stroke
Shear tilt	4.50 in. (114.5 mm)	2.25 in. (57.2 mm)	31.26 in. (794 mm)
Grapple clamps (2)	4.00 in. (101.5 mm)	1.75 in. (44.5 mm)	5.51 in. (140 mm)
Shear (double acting)	6.50 in. (165 mm)	2.50 in. (63.5 mm)	19.88 in. (505 mm)

Capacities:	U.S.	Imp.	Liters
Fuel tank	50 gal.	41.7 gal.	189.2
Cooling system	9 gal.	7.5 gal.	34.1
Engine lubrication, including filter	20 qt.	16.7 qt.	18.9
Transmission	12.2 gal.	10.2 gal.	46.2
Hydraulic reservoir	24 gal.	20 gal.	90.8
Front differential	26 qt.	21.7 qt.	24.6
Rear differential	26 qt.	21.7 qt.	24.6

SAE Operating Weight 36,900 lb. (16 750 kg)

Additional Standard Equipment:

- Bottom guards
- Cab with ROPS, heater, air conditioner, and protective windows
- Cigar lighter
- Cushion seat with position adjustment and seat belt
- Engine side shields
- Cold weather starting aid
- Fire extinguisher
- Gauges:
 - Electric hour meter
 - Engine coolant temperature
 - Engine oil pressure
 - Fuel
 - Voltmeter
- Hand and foot throttle
- Heavy-duty starter
- Frame locking bar
- Horn
- Hydraulic oil warmup switch
- Hydraulic pump discharge filter
- Indicator lights:
 - Hydraulic oil sump level
 - Hydraulic oil temperature
 - Transmission oil temperature
 - Transmission oil pressure
- Key switch with pushbutton safety start
- Lights
- Muffler with rain deflector and protective guard
- Parking brake
- Transistorized voltage regulator
- Vandal protection
- Windshield wiper and washer

Special Equipment:

- 3 in. (76 mm) seat belt
- Automatic fire suppression system
- Multi-stem shear
- Radio
- Steering accumulator

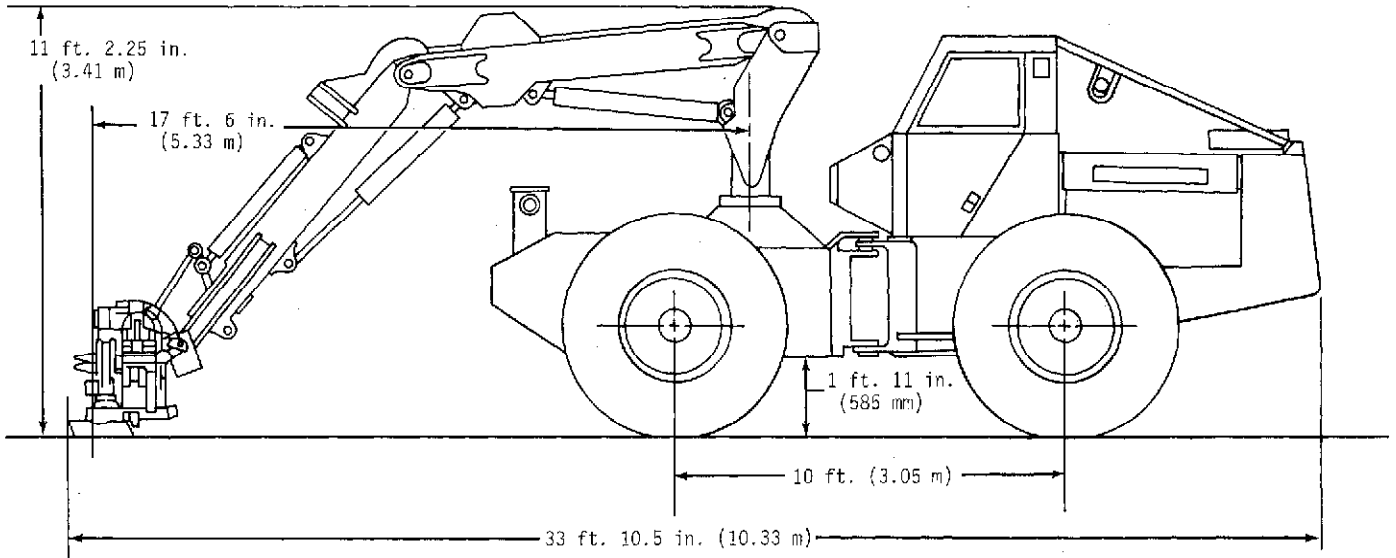

T50022N

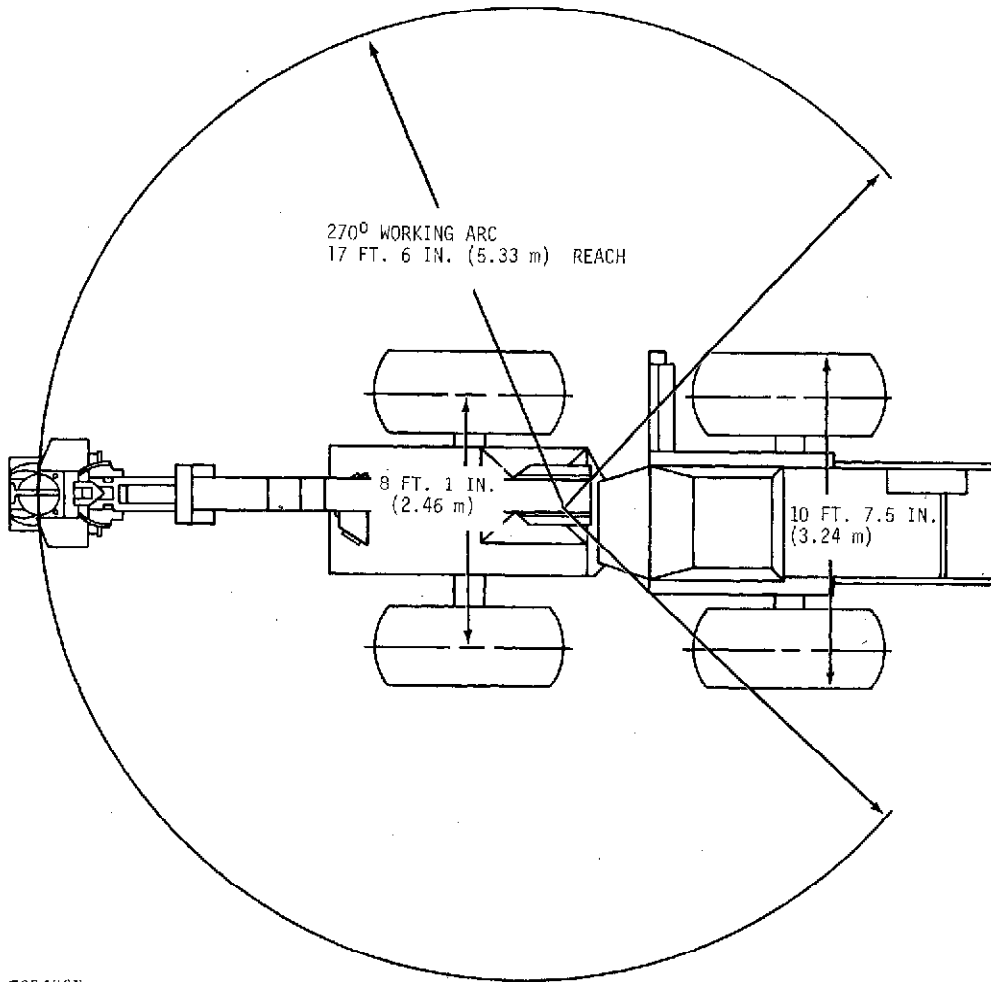

T23480N

Group IV PREDELIVERY, DELIVERY, AND AFTER-SALE SERVICES

TEMPORARY STORAGE

After receiving your tree harvester or feller-buncher from the factory and before putting tree harvester or feller-buncher into temporary storage, perform following checks.

1. Check battery electrolyte level and charge batteries, if necessary.
2. Check coolant level in radiator. Coolant should be maintained at a level midway between radiator core and filler neck.
3. Check crankcase oil level. Oil should be between marks on dipstick after machine has been shut down for 10 minutes.
4. Relieve hydraulic pressure by stopping engine, lowering boom and tree support blade and operating boom and tree support blade control levers until system fails to respond.

PREDELIVERY SERVICE

Because of shipping factors involved, plus extra finishing touches that are necessary to promote customer satisfaction, proper predelivery service is of prime importance to dealer and customer.

If adjustments are required, procedures are found in after-sale section.

Use following list when preparing a tree harvester or feller-buncher for delivery to customer.

1. Air Cleaner

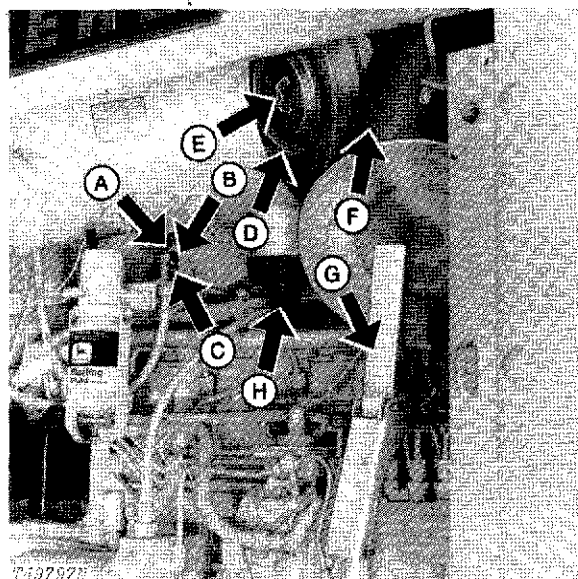

- | | |
|-------------------------|-------------------|
| A—Reset Button | E—Wing Nut |
| B—Restriction Indicator | F—Primary Element |
| C—Red Signal | G—Lever |
| D—Safety Element | H—Unloader Valve |

Fig. 1—Air Cleaner Components

Check air filter restriction indicator. If red signal locks in full view, look for restriction or blockage in air intake system.

Air cleaner elements checked	Yes	No
Restriction in system	Yes	No

2. Air Intake Hose

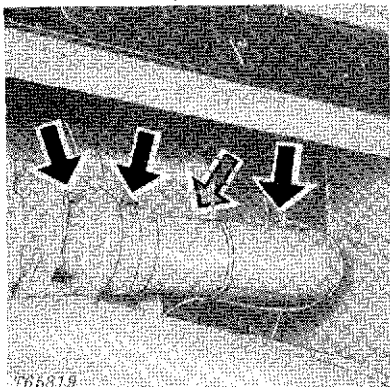

Fig. 2-Hose Clamps

Check clamps on hose connecting air cleaner and engine. Tighten hose clamps. Inspect hose for cracks.

Air intake hose checked Yes No

Loose connections Yes No

3. Radiator

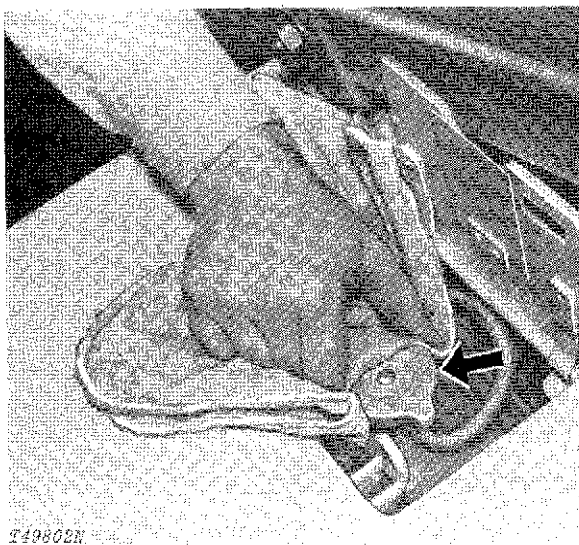

Fig. 3-Radiator Filler Cap

CAUTION: Do not remove radiator filler cap until coolant temperature is below its boiling point. Then loosen cap slowly to stop to relieve any excess pressure before removing cap completely.

Check coolant level in radiator. Coolant should be maintained at a level midway between radiator core and filler neck.

The antifreeze-water ratio is approximately 50 percent each. This protects to at least -34°F (-37°C).

Radiator coolant level checked Yes No

4. Batteries

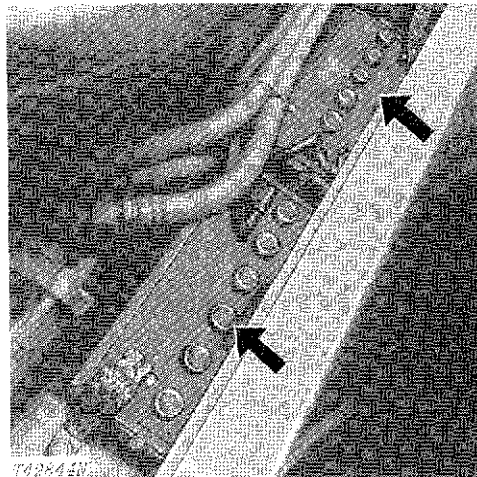

Fig. 4-Batteries

Remove foreign material from top of batteries. Check battery electrolyte level. If distilled water is not available, use clean soft water. Coat terminals with petroleum jelly.

IMPORTANT: Never add water to batteries in freezing weather unless engine is to be run 2 or 3 hours to assure mixing of water and electrolyte.

Check battery connections.

Punch date code on battery.

Water added Yes No

Battery connections checked Yes No

5. Tire Pressure

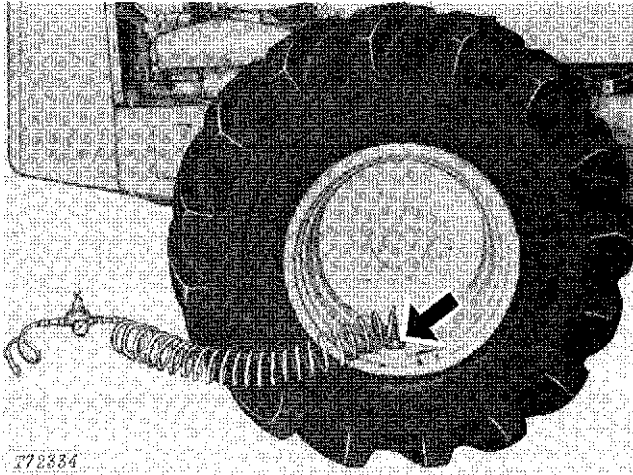

Fig. 5-Correct Tire Filling Procedure

Check air pressure in tires with an accurate gauge having 7 kPa (0.07 bar) 1 psi graduations.

Tire Size	Type	Ply Rating	Operating Pressure
30.5-32	LS-2	12	165 kPa (1.65 bar) (24 psi)
30.5-32	LS-2	16	172 kPa (1.7 bar) (25 psi)
30.5-32*	LS-2	16	172 kPa (1.7 bar) (25 psi)

*Kevlar Ply (Canada only)

CAUTION: Failure to follow proper procedures when mounting a tire on a wheel or rim can produce an explosion which may result in serious bodily injury. DO NOT attempt to mount a tire unless you have proper equipment and experience to perform job safely.

Detailed tire mounting instructions, including necessary safety precautions are contained in John Deere Fundamentals of Service (FOS) Manual 55, **Tires and Tracks.**

Tire pressure checked Yes No

6. Crankcase Oil Level

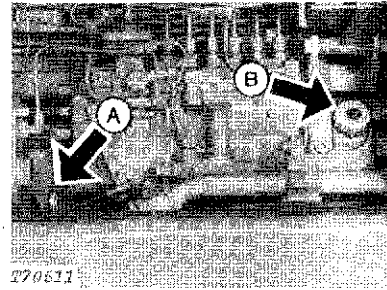

A—Dipstick

B—Oil Filler Cap

Fig. 6-Crankcase Oil Level

Check crankcase oil level with tree harvester or feller-buncher on level ground. (Allow a minimum of 10 minutes for oil to drain down before checking.) If oil level is at or below bottom mark on dipstick, add oil specified on page I-V-2 to bring oil level to between marks on dipstick. Do not operate engine with oil level below bottom mark.

Crankcase oil level checked Yes No
 Oil added, if any _____ qts (L)

7. Transmission Oil Level

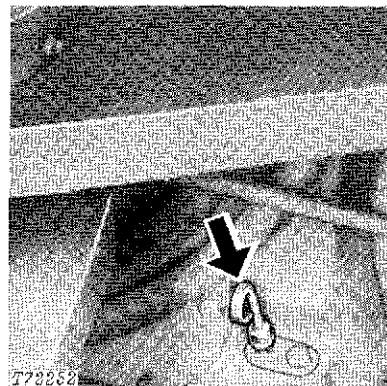

Fig. 7-Dipstick

Check transmission oil level with tree harvester or feller-buncher on level ground and engine off. (Allow a minimum of five minutes for oil to drain down before checking.)

If oil level is at or below bottom mark on dipstick, add oil specified on page I-V-2 to bring oil level to between marks on dipstick. Do not operate with oil level below bottom mark or above top mark.

Transmission oil level checked Yes No
 Oil added, if any _____qts (L)

8. Hydraulic System Oil Level

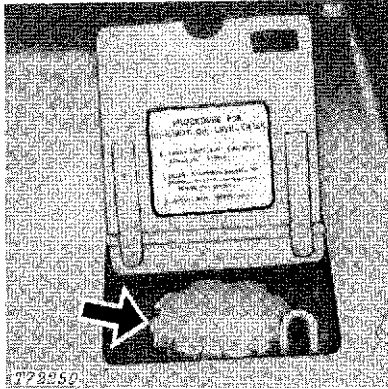

Fig. 8-Filler Cap

Check oil level with:

- 1 - Machine articulated to the right;
- 2 - Tree support blade lowered;
- 3 - Shear closed;
- 4 - Grapple tongs closed;
- 5 - Delimber knives closed;
- 6 - Feed rolls opened;
- 7 - Shear extended off left-hand front corner of equipment frame with shear upright on ground and secondary boom cylinder fully extended.

Check oil level as follows:

- 1 - Stop engine. Look at sight glass on reservoir tank. If oil does not cover entire sight glass, proceed to step #2.
- 2 - Check oil level on bayonet gauge in hydraulic reservoir tank. Oil level should be to FULL mark on bayonet gauge while resting on top of strainer located beneath filler cap.
- 3 - If oil level is low, add oil specified on page I-V-2.

Oil level checked Yes No
 Oil added, if any _____qts (L)

9. Delimber Gearboxes Oil Level

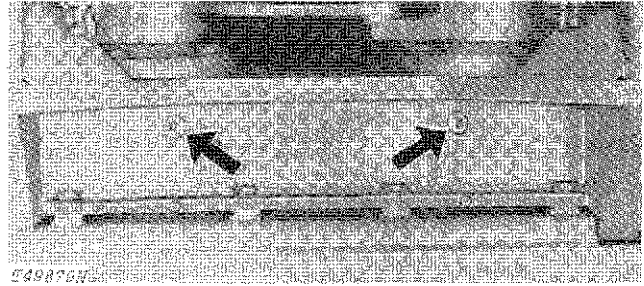

Fig. 9-Check and Fill Plugs

Remove plugs to check oil level in delimb gear boxes. Oil level should be to filler holes.

If oil level is low, add oil specified on page I-IV-2.

Delimber gearboxes oil level checked Yes No
 Oil added, if any _____qts (L)

10. Delimber Final Drives Oil Level

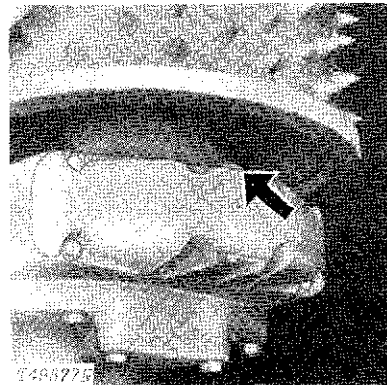

Fig. 10-Left Check and Fill Plug

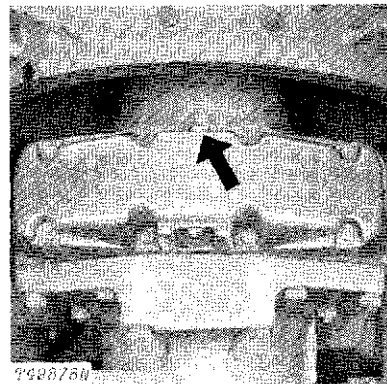

Fig. 11-Right Check and Fill Plug

Remove plugs to check oil level in delimeter final drives. Oil level should be to filler holes.

If oil level is low, add oil specified on page I-V-2.

Delimeter final drives oil level checked Yes No

Oil added, if any _____qts (L)

11. Differential Housings Oil Level

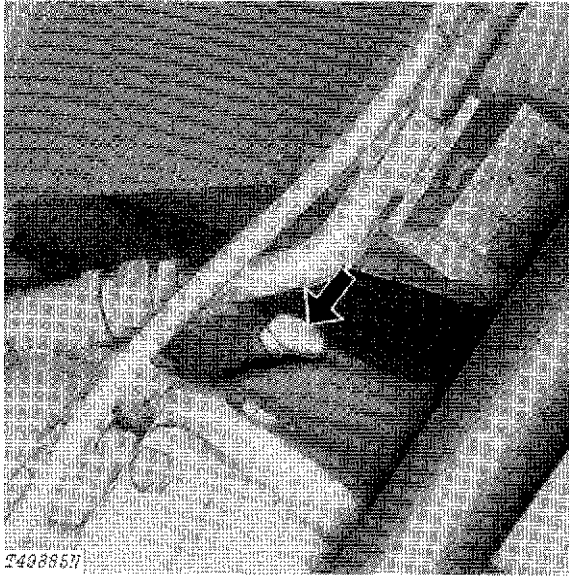

Fig. 12-Front Differential Oil Level and Fill Plug

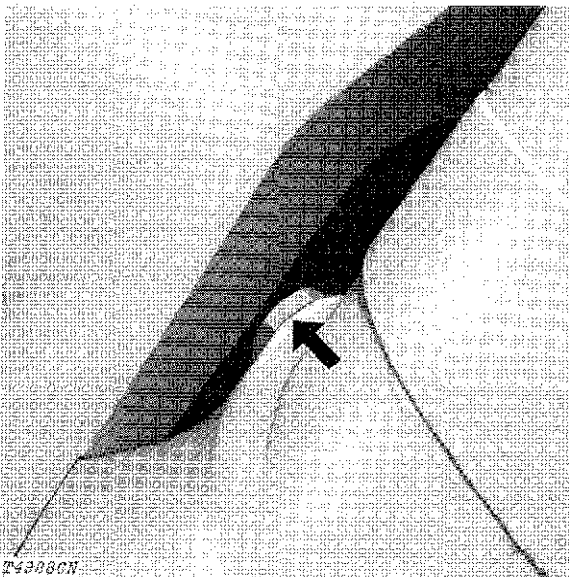

Fig. 13-Rear Differential Oil Level and Fill Plug

Check oil level in front and rear differential housings. If oil level is low, add oil specified on page I-V-2.

Differential housings oil levels checked Yes No

Oil added, if any _____qts (L)

12. Fuel Filters

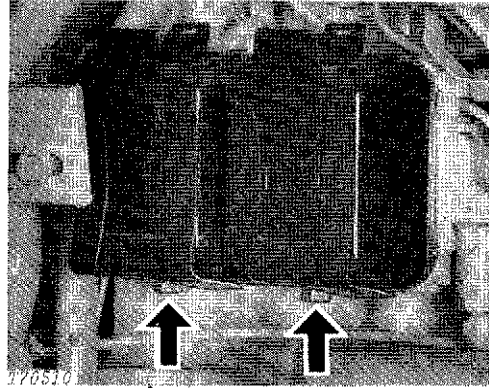

Fig. 14-Drain Plugs

Check fuel filter for sediment. If necessary, drain as follows:

- 1 - Loosen drain plugs.
- 2 - Allow all fuel to drain from filters.
- 3 - Tighten drain plugs.
- 4 - Drain fuel tank sump if water is present in fuel filters (see page I-IV-7).
- 5 - Bleed fuel system (see page I-IV-33).

Sediment present in filter Yes No

13. Fuel Transfer Pump Sediment Bowl

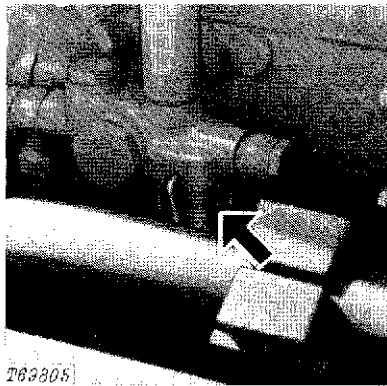

T69805

Fig. 15-Filter Screen

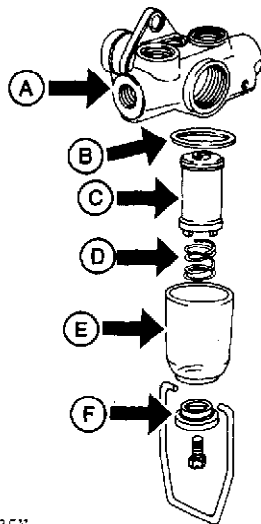

T49785N

- A—Housing
- B—Gasket
- C—Filter
- D—Spring
- E—Filter Housing
- F—Clamping Nut

Fig. 16-Fuel Transfer Pump Sediment Bowl Components

- 1 - Loosen clamping nut (F, Fig. 16) holding filter housing (E).
- 2 - Remove filter housing, spring (D), filter (C), and gasket (B).
- 3 - Clean filter. Replace if necessary.
- 4 - Install gasket, filter, spring, and filter housing.
- 5 - Tighten clamping nut tight.
- 6 - Bleed fuel system (see page I-IV-33).

Fuel transfer pump filter checked Yes No

Fuel transfer pump filter cleaned Yes No

14. Fuel Tank Filler Screen

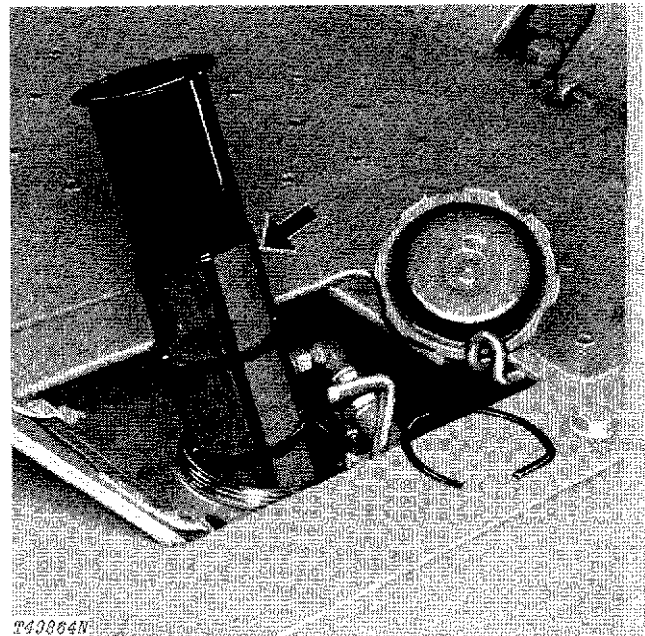

T43864N

Fig. 17-Filler Screen

To clean screen:

- 1 - Remove fuel tank cap.
- 2 - Remove screen.
- 3 - Clean screen with diesel fuel.
- 4 - Install screen.
- 5 - Install fuel tank cap.

Fuel tank filler screen checked Yes No

Fuel tank filler screen cleaned Yes No

15. Fuel Tank Sump

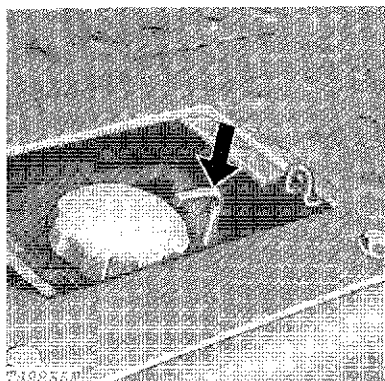

Fig. 18-Drain Handle

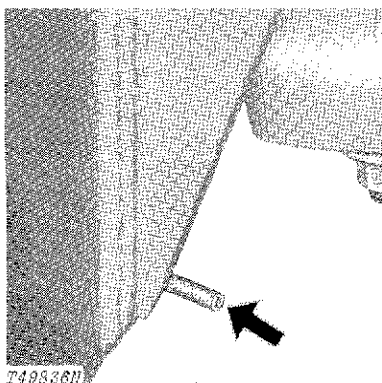

Fig. 19-Sump Drain

Drain fuel tank sump as follows:

- 1 - Open sump drain valve by turning sump drain handle 90° to the right (clockwise).
- 2 - Drain for 3 seconds.
- 3 - Turn sump drain handle back (counterclockwise) to close sump drain valve.

Fuel tank sump checked	Yes	No
Fuel tank sump drained	Yes	No

16. Alternator-Fan-Compressor Belt Tension

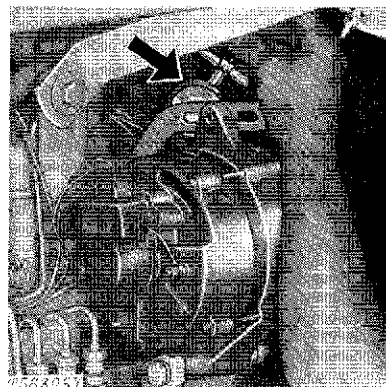

Fig. 20-Tension Tester Gauge

Check alternator belt tension. If tension tester gauge is used, a force of 76 N (17 lb.) midway between pulleys should deflect belt 1/4-inch (6 mm).

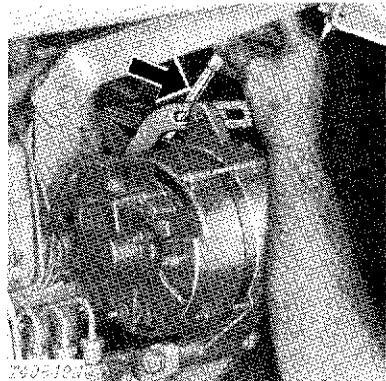

Fig. 21-Strand Tension Gauge

If strand tension gauge is used, it should read 400 N (90 lb. force) strand tension.

If adjustment is required, see page I-IV-34.

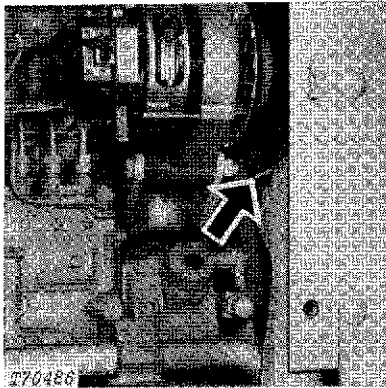

Fig. 22-Tension Tester Gauge

Check fan belt tension. If tension tester gauge is used, a force of 111 N (25 lb.) midway between pulleys should deflect belts 3/4-inch (19 mm).

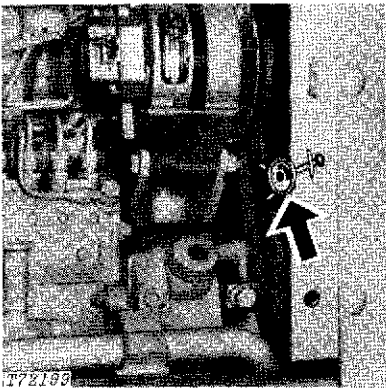

Fig. 23-Strand Tension Gauge

If strand tension gauge is used, it should read 400 N (90 lb. force) strand tension.

If adjustment is required, see page I-IV-35.

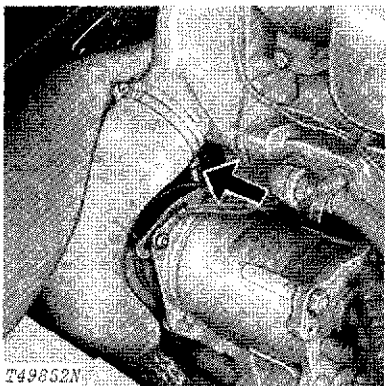

Fig. 24-Tension Tester Gauge

Check compressor belt tension. If tension tester gauge is used, a force of 67 N (15 lb.) midway between pulleys should deflect belt 1/4 inch (6 mm).

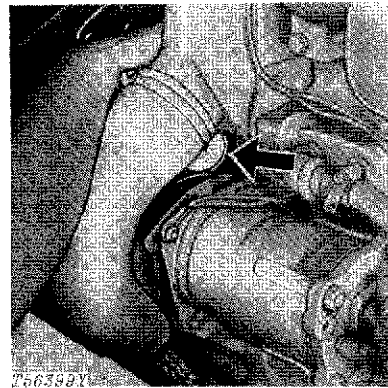

Fig. 25-Strand Tension Gauge

If strand tension gauge is used, it should read 400 N (90 lb. force) strand tension.

If adjustment is required, see page I-IV-35.

Alternator belt tension	_____ N (lb. force) tension
	_____ inch (mm) flex
Fan belt tension	_____ N (lb. force) tension
	_____ inch (mm) flex
Compressor belt tension	_____ N (lb. force) tension
	_____ inch (mm) flex

17. Grease Fittings

The tree harvester or feller-buncher was checked and lubricated before it left the factory. However, to insure customer satisfaction, check each lubrication point shown on following pages. Lubricate with several strokes of John Deere Multi-Purpose Grease or equivalent, if necessary.

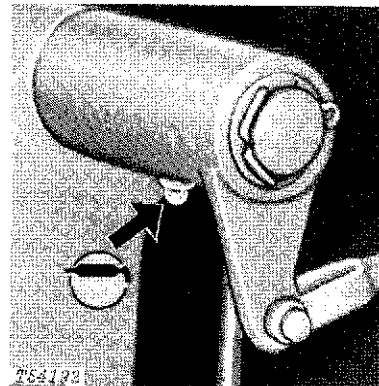

Fig. 26-Parking Brake Bell Crank (1 Point)

Lubricant required

Yes No

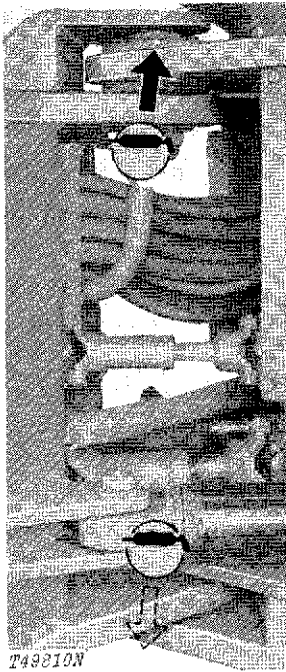

Fig. 27-Frame Hinge Pivots (2 Points)

Lubricant required

Yes No

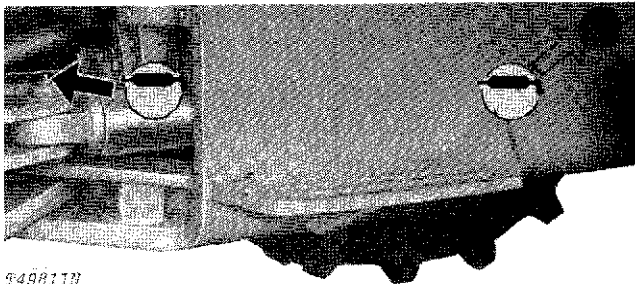

Fig. 28-Steering Cylinder Pivot Pins (4 Points)

Lubricant required

Yes No

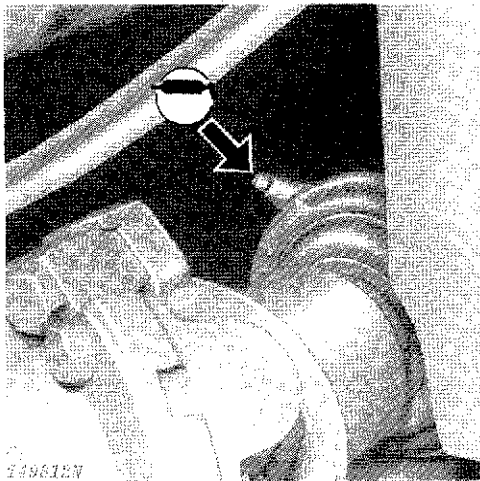

Fig. 29-Lower Drive Shaft Support Bearing (1 Point)

Lubricant required

Yes No

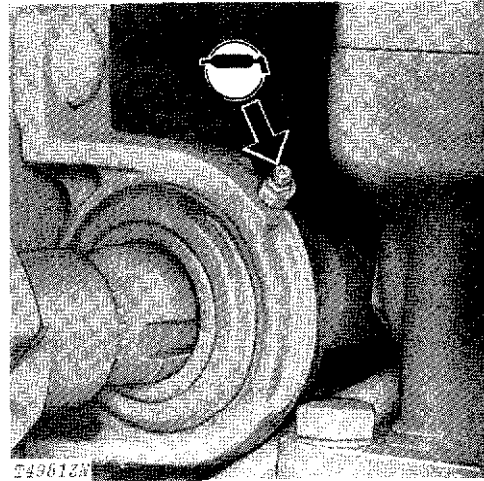

Fig. 30-Delimiter Transmission Drive Shaft Support Bearing (1 Point)

Lubricant required

Yes No

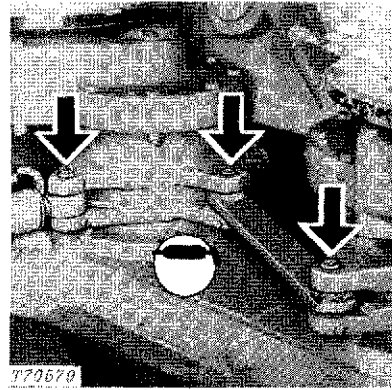

Fig. 31-Feed Roll Cylinder Rod End Pivot and Feed Roll Crosslink (3 Points)

Lubricant required

Yes No

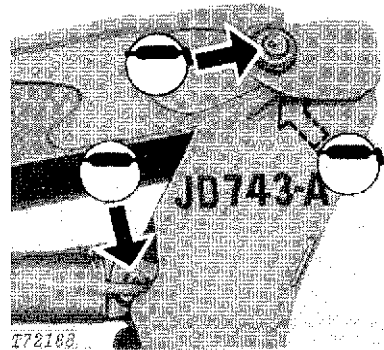

Fig. 32-Booms and Mast (3 Points)

Lubricant required

Yes No

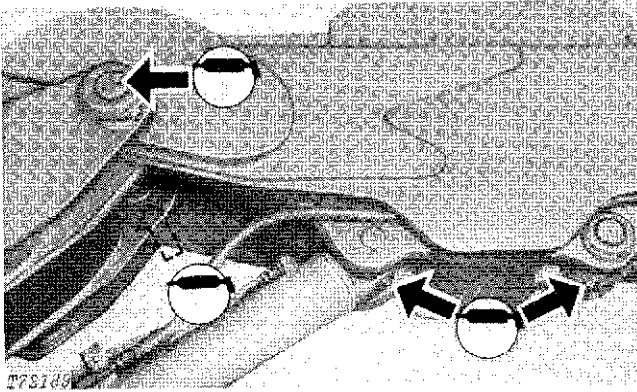

Fig. 33-Booms (4 Points)

Lubricant required

Yes No

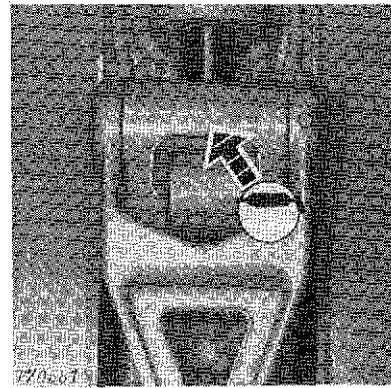

Fig. 36-Tilt Cylinder Rod End (1 Point)

Lubricant required

Yes No

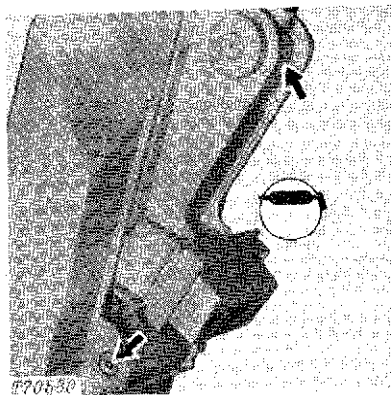

Fig. 34-Secondary Boom Cylinder Rod End and Tilt Linkage (2 Points)

Lubricant required

Yes No

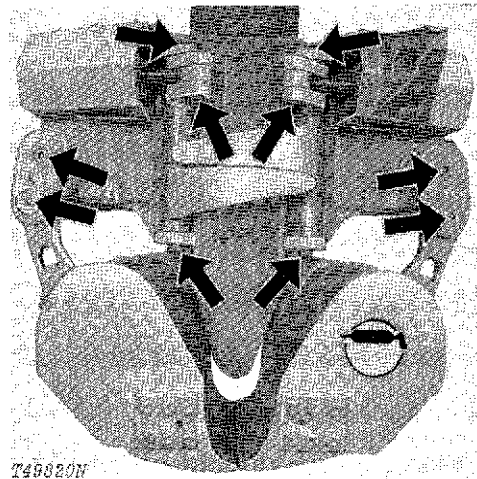

Fig. 37-Tree Shear (10 Points)
Standard Grapple Tong

Lubricant required

Yes No

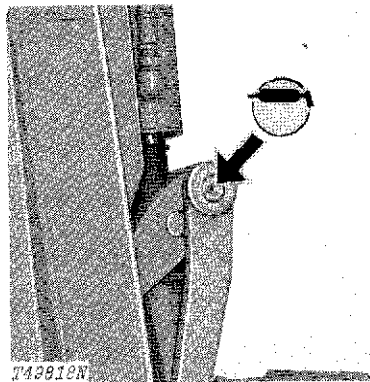

Fig. 35-Tilt Linkage (1 Point)

Lubricant required

Yes No

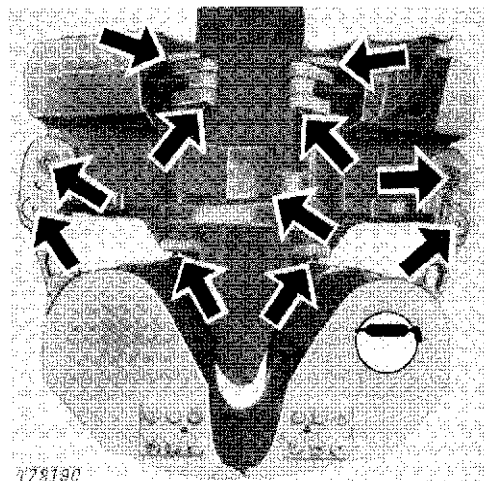

Fig. 38-Tree Shear (11 Points)
Multi-Stem Grapple Tong

Lubricant required

Yes No

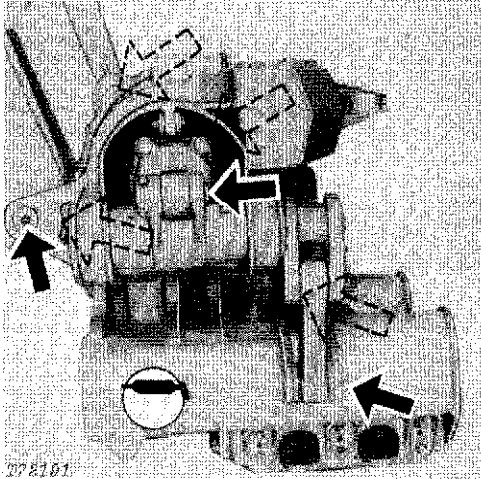

Fig. 39-Tree Shear (7 Points)

Lubricant required

Yes No

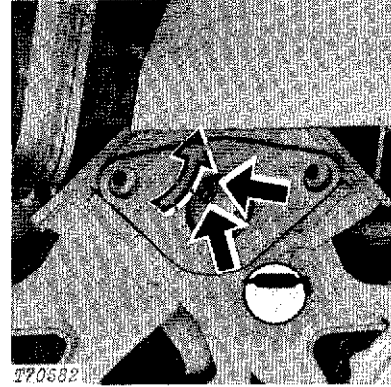

Fig. 42-Shear Blade Pivot Shaft (Rear) (3 Points)

Lubricant required

Yes No

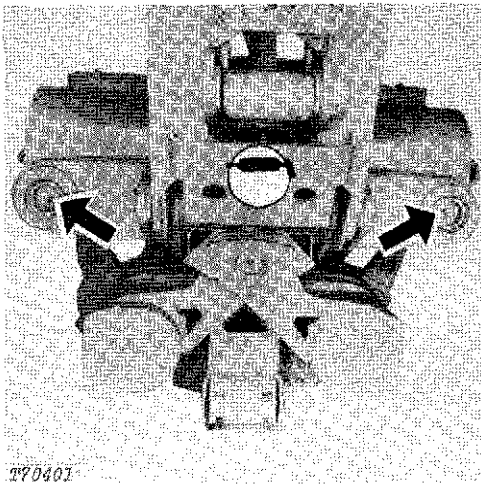

Fig. 40-Tree Shear (2 Points)

Lubricant required

Yes No

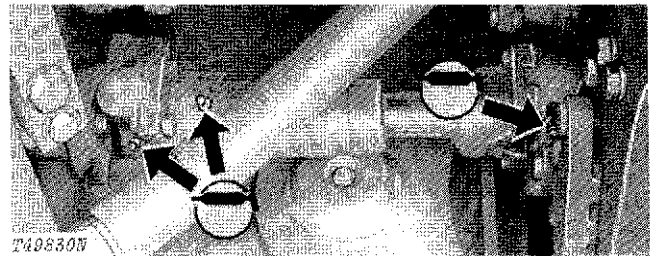

Fig. 43-Lower Telescoping Universal Joints (3 Points)

Lubricant required

Yes No

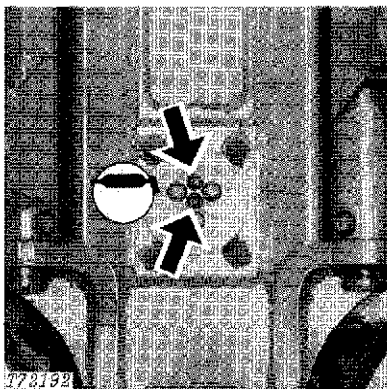

Fig. 41-Shear Blade Pivot Shaft (Front) (2 Points)

Lubricant required

Yes No

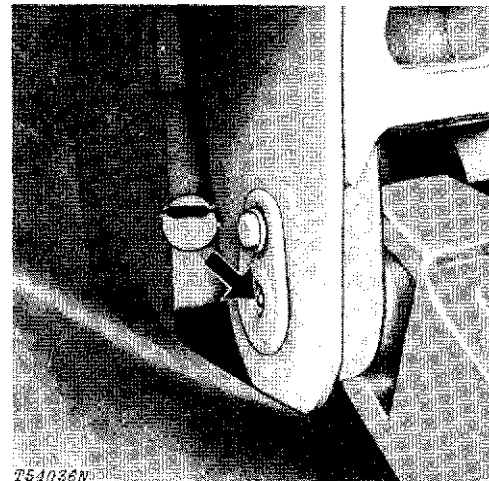

Fig. 44-Rear Tree Support Blade Pivots (2 Points)

Lubricant required

Yes No

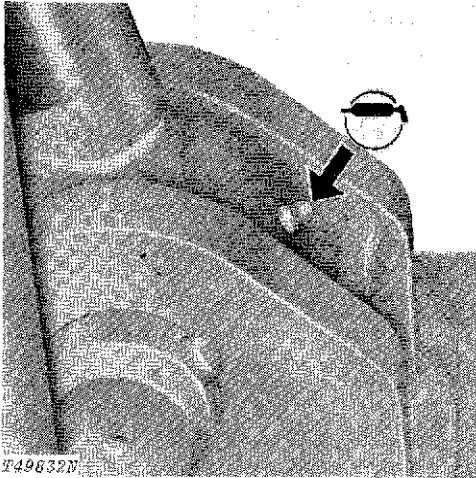

Fig. 45-Axle Stabilizer Cylinder (1 Point)

Lubricant required

Yes No

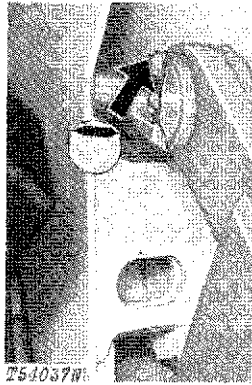

Fig. 46-Tree Support Blade Cylinder (1 Point)

Lubricant required

Yes No

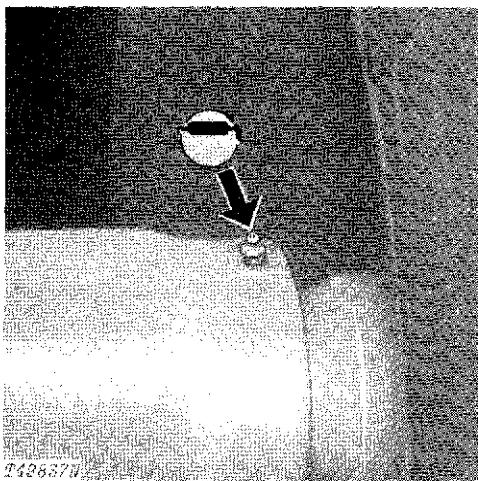

Fig. 47-Axle Bearings (4 Points)

Use John Deere High-Temperature Grease or equivalent.

Lubricant required

Yes No

Litho in U.S.A.

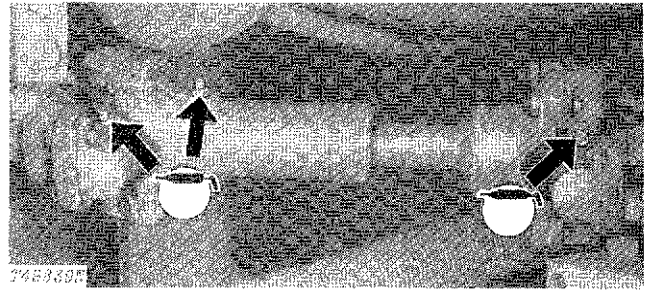
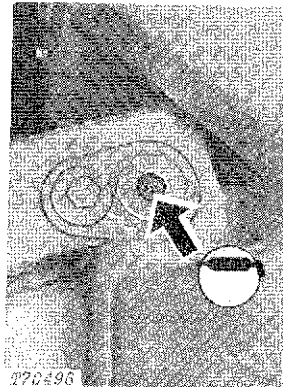

Fig. 48-Delimiter Drive Line (3 Points)

Lubricant required

Yes No



Left

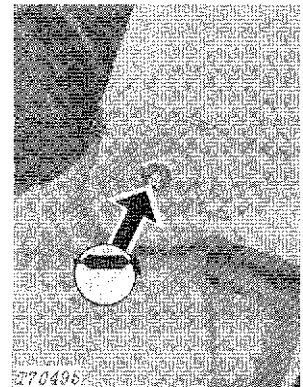

Right

Fig. 49-Delimiter Carriage Pivot Pins (2 Points)

Lubricant required

Yes No

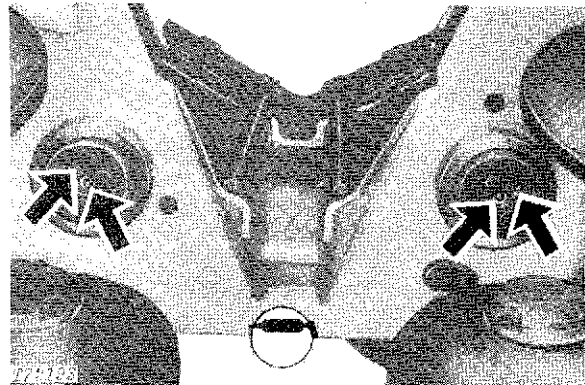

Fig. 50-Knife Bushings (4 Points)

Lubricant required

Yes No

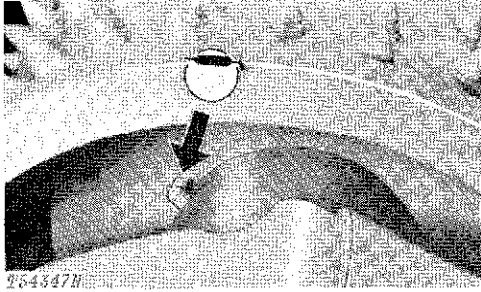

Fig. 51-Feed Roll Final Drive Shaft Upper Bearing (2 Points)
 (Right Side Shown)

Lubricant required Yes No

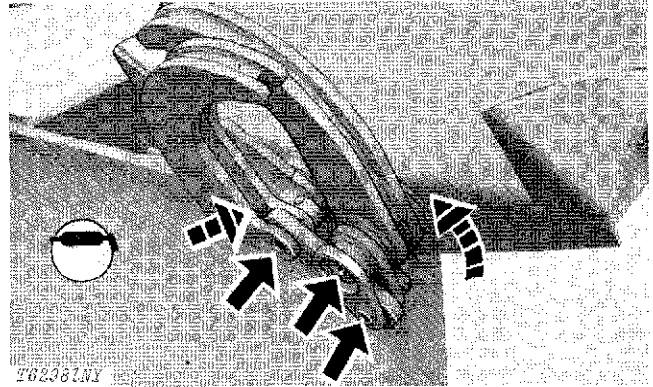

Fig. 54-Log Accumulator (5 Points)

Lubricant required Yes No

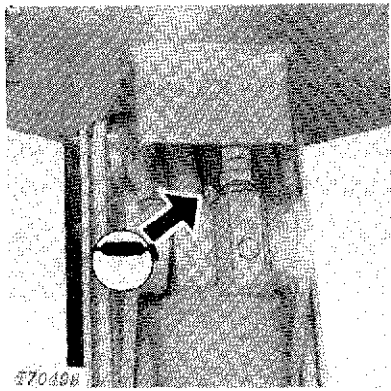

Fig. 52-Tilt Cylinder Head End (1 Point)

Lubricant required Yes No

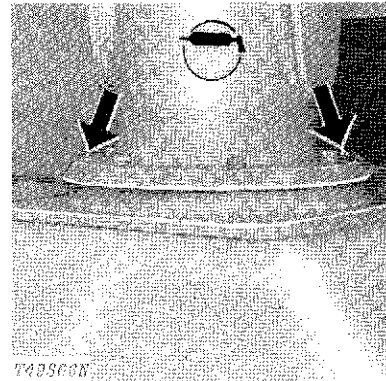
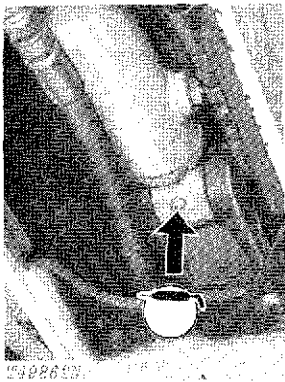
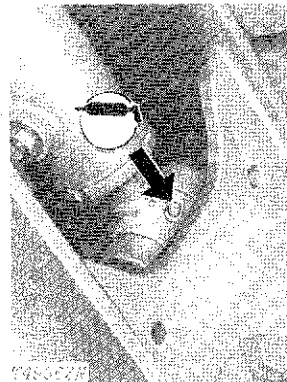

Fig. 55-Upper Swing Bearing (2 Points)

Lubricant required Yes No



Left



Right

Fig. 53-Delimb Cylinders (2 Points)

Lubricant required Yes No

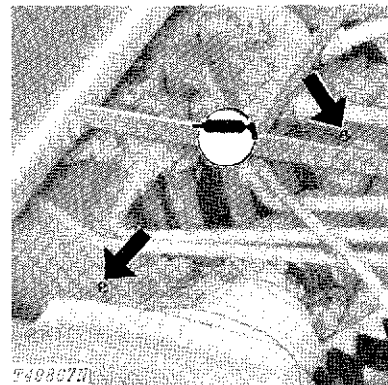

Fig. 56-Lower Swing Bearing (2 Points)

Lubricant required Yes No

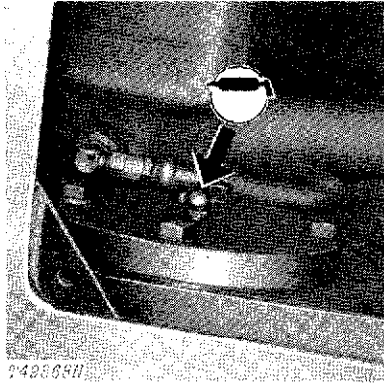

Fig. 57-Upper Cluster Gear Shaft Bearing (1 Point)

Lubricant required Yes No

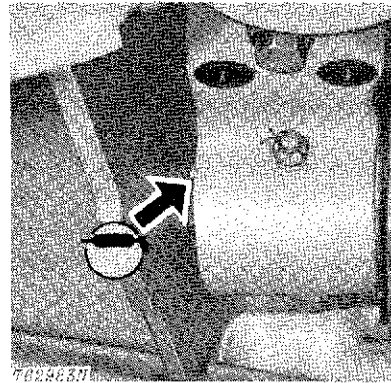

Fig. 60-Rear Axle Pivot Pin (Front) (1 Point)

Lubricant required Yes No

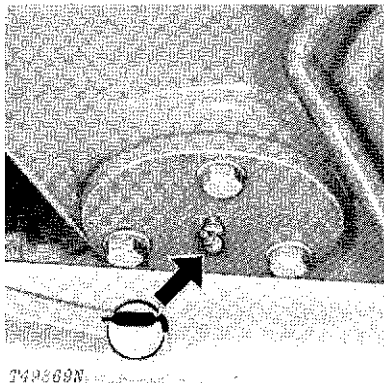

Fig. 58-Lower Cluster Gear Shaft Bearing (1 Point)

Lubricant Required Yes No

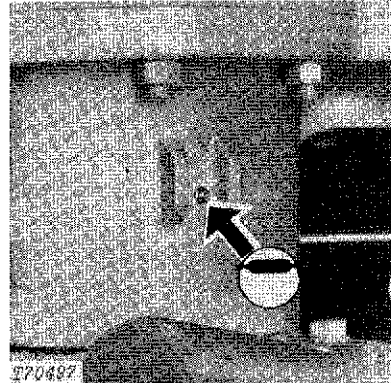

Fig. 61-Left Feed Roll Final Drive Main Housing Pivot (1 Point)

Lubricant required Yes No

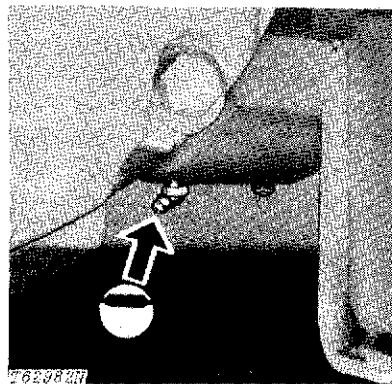

Fig. 59-Rear Axle Pivot Pin (Rear) (1 Point)

Lubricant required Yes No

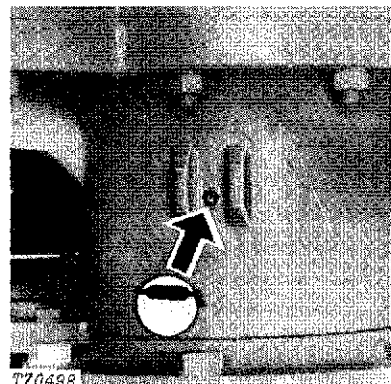

Fig. 62-Right Feed Roll Final Drive Main Housing Pivot (1 Point)

Lubricant required Yes No

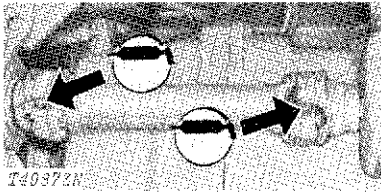

Fig. 63-Rear Axle Universal Joints (2 Points)

Lubricant required Yes No

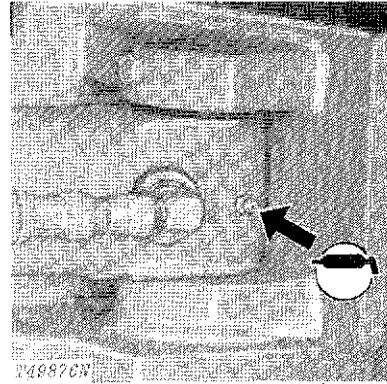

Fig. 66-Feed Roll Cylinder Head End (1 Point)

Lubricant required Yes No

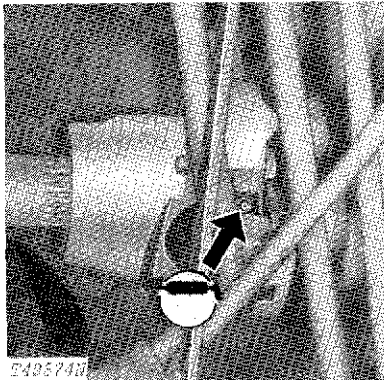

Fig. 64-Front Axle Universal Joint (1 Point)

Lubricant required Yes No

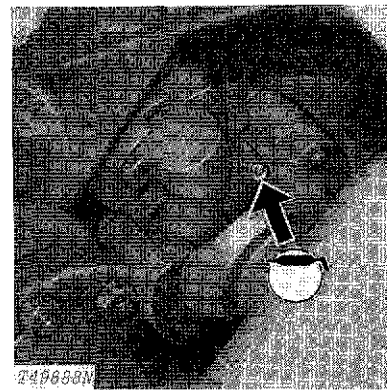

Fig. 67-Engine-to-Transmission Universal Joint (Transmission End) (1 Point)

Lubricant required Yes No

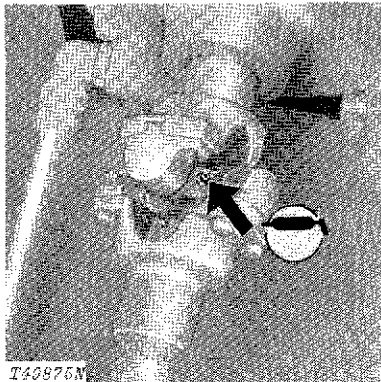

Fig. 65-Delimb Drive Universal Joint (1 Point)

Lubricant required Yes No

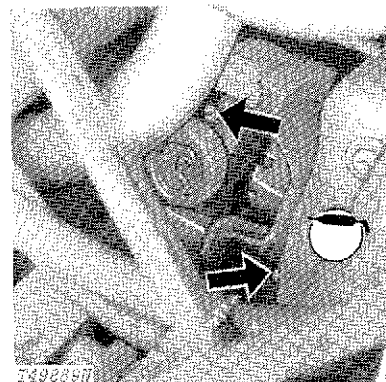

Fig. 68-Engine-to-Transmission Universal Joint (Engine End) and Engine Disconnect Clutch Bearing (2 Points)

Lubricant required Yes No

18. Engine Speeds

Warm up engine and attach a tachometer in engine rotation tool hole to check engine speeds.

No load, fast idle speed should be 2350 rpm. Slow idle should be 800 rpm.

If engine speeds need adjustment, see page I-IV-44.

Engine speeds checked Yes No

19. Indicator Lights and Gauges

When operating tree harvester or feller-buncher, check following gauges and indicator lights for correct operation.

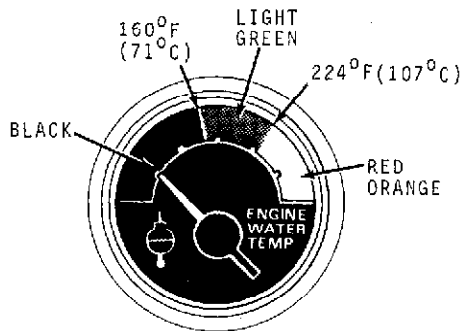

T38573

Fig. 69-Engine Coolant Temperature Gauge

Normal operating range is indicated by light green area on gauge face. Check cooling system if indicator hand goes into red-orange zone.

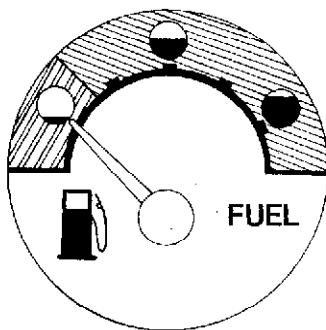

T40227N

Fig. 70-Fuel Gauge

The fuel gauge indicates amount of fuel remaining in fuel tank.

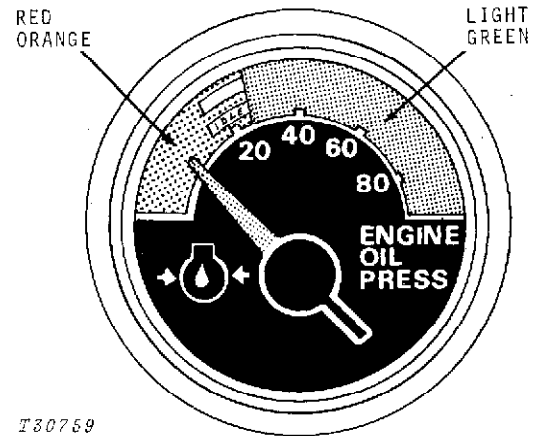

T30759

Fig. 71-Engine Oil Pressure Gauge

Normal operating range is indicated by green zone on gauge face.

If engine oil pressure indicator hand is not in green zone, stop engine and check oil level.

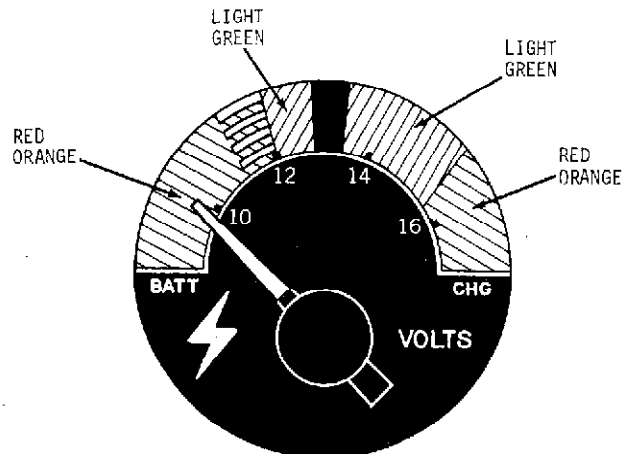

T44553

Fig. 72-Voltmeter

With key switch on and engine off, indicator should be in left light green zone.

When cranking engine, indicator will fall into left-hand orange zone. When engine starts, indicator should move to stay in right light green zone.

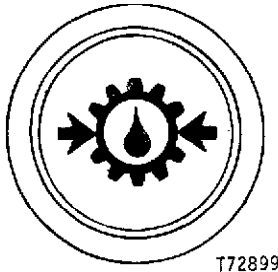

T72899

Fig. 73-Transmission Oil Pressure Indicator Light

When engine is running, transmission oil pressure indicator light should go out. If light glows while engine is running, stop engine and check transmission oil level or for restricted filter.

NOTE: Light should glow, if operative, with key switch in start position and engine off.

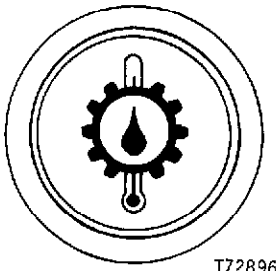

T72896

Fig. 74-Transmission Oil Temperature Indicator Light

When engine is running, transmission oil temperature indicator light should go out. If light glows while engine is running, stop engine and check transmission oil level or for restricted filter.

NOTE: Light should glow, if operative, with key switch in start position and engine off.

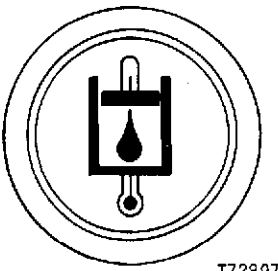

T72897

Fig. 75-Hydraulic Oil Temperature Indicator Light

When engine is running, hydraulic oil temperature indicator light should go out. If light glows when engine is running, stop engine and check hydraulic oil level for restricted filters.

NOTE: Light should glow, if operative, with key switch in start position and engine off.

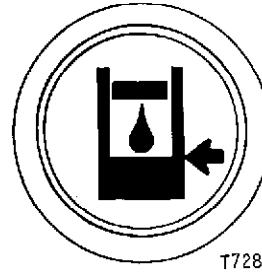

T72898

Fig. 76-Hydraulic Oil Level Indicator Light

When engine is running, hydraulic oil level indicator light should go out. If light glows while engine is running, stop engine and check hydraulic oil level.

NOTE: Light should glow, if operative, with key switch in start position and engine off.

Indicator lights and gauges operational

Yes No

20. Transmission Shifting



Fig. 77-Transmission Control Lever

Check operation of tree harvester or feller-buncher in all gears.

Transmission checked

Yes No

21. Axle Stabilizer Operation

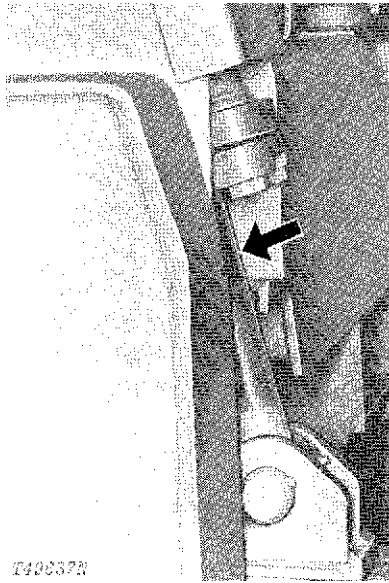

Fig. 78-Axle Stabilizer Cylinder

Check operation of axle stabilizer for stability of rear axle.

Move transmission control lever to neutral position. The axle stabilizer automatically engages with engine running.

Move transmission control lever out of neutral position. The axle stabilizer will automatically disengage with engine running.

Axle stabilizer operational Yes No

22. Fire Extinguisher

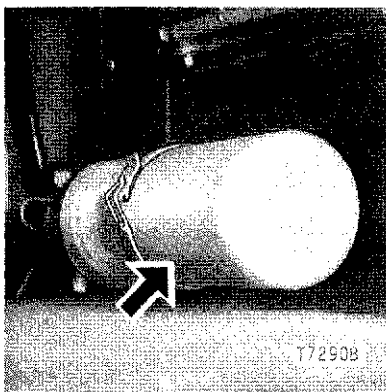

Fig. 79-Fire Extinguisher

Check gauge for proper charge. If not fully charged, recharge extinguisher.

Replace if corrosion or damage is present.

Fire extinguisher operational Yes No

23. Hydraulic Brakes

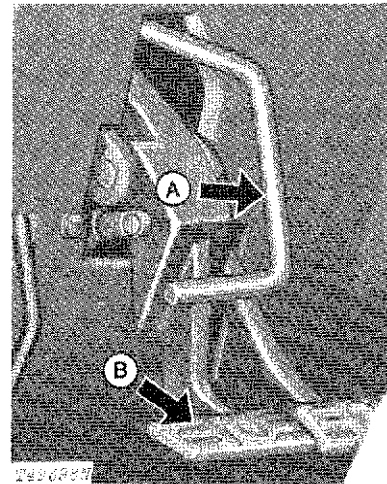

A—Brake Lock Pedal

B—Service Brake Pedal

Fig. 80-Brake and Lock Pedals

Check brake system for leaks or improper operation.

Put tree harvester or feller-buncher in gear and depress brake pedal. Moderate pedal force should hold tree harvester or feller-buncher in place.

If pedal force does not hold tree harvester or feller-buncher in place, pedal feels spongy or bottoms out, repair is required, or system may require bleeding (see page I-IV-45).

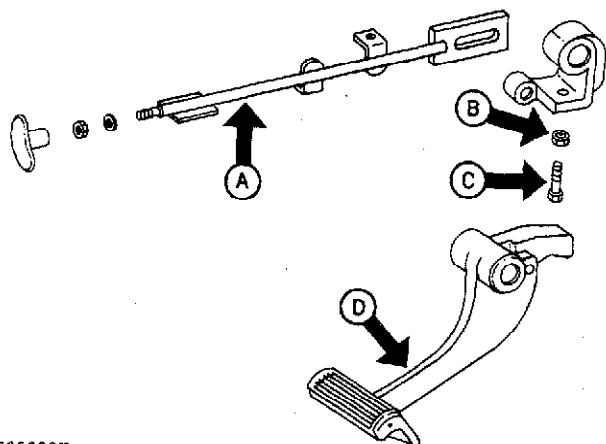

T85082N

A—Brake Lock Rod
 B—Nut

C—Cap Screw
 D—Brake Pedal

Fig. 81—Service Brake Lock Adjustment

Shift to neutral and run engine at 1/2 throttle. Depress brake pedal with 445-534 N (100-120 lb.) force. Shift to third speed forward. Slowly release clutch pedal until engine speed lugs down to slow idle. Tree harvester or feller-buncher should not move while engine lugs down to slow idle or slower.

IMPORTANT: Do not continue above check for more than five seconds at reduced engine rpm.

CAUTION: Tree harvester or feller-buncher will move forward if service brake linkage is not properly adjusted.

If tree harvester or feller-buncher moves, adjust as follows:

- 1 - Place brake lock rod (A, Fig. 81) in extended position.
- 2 - Adjust cap screw (C) to just contact brake pedal boss.
- 3 - Lock in place with nut (B).
- 4 - With lock in this position and no force on pedal, move brake lock rod to disengage the locking feature.
- 5 - The brake lock rod should return only part way to the normally disengaged position.
- 6 - Depress brake pedal with more than 445 N (100 lb.) force.
- 7 - The brake lock rod should return to the normally disengaged position with a very definite snap.

Brakes operational	Yes	No
Service brake lock checked	Yes	No

24. Parking Brake

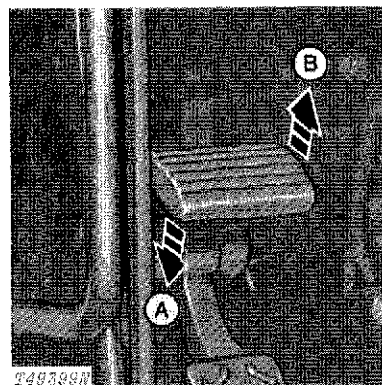

A—Engage B—Disengage

Fig. 82—Parking Brake Pedal

Check parking brake adjustment.

Push parking brake pedal down and slide parking brake lock to left to engage parking brake.

If adjustment is required, see page I-IV-45.

Parking brake operational	Yes	No
---------------------------	-----	----

25. Differential Lock

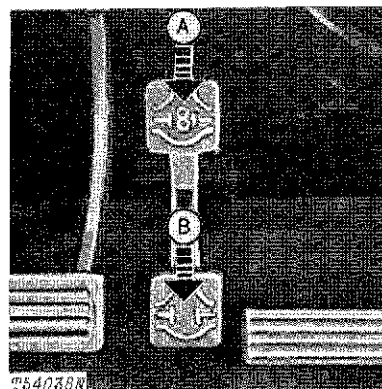

A—Engaged B—Disengaged

Fig. 83—Differential Lock Pedal

Check differential lock operation.

With engine off and differential lock engaged, steering wheel cannot be rotated more than approximately 20° in each direction.

With engine off and differential lock disengaged, steering wheel can be rotated approximately 40° in each direction.

Differential lock checked	Yes	No
---------------------------	-----	----

26. Power Steering

Check power steering. Tree harvester or feller-buncher should turn to left and right with ease.

Check lines and cylinders for leakage.

Power steering checked Yes No

27. Accumulator Action

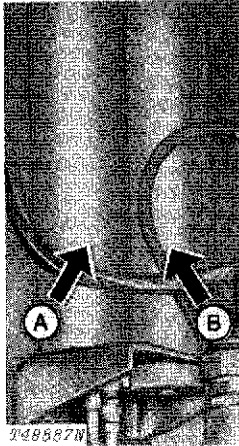

A—Hydraulic System Accumulator

B—Brake Accumulator

Fig. 84-Accumulators

Check accumulator action as follows:

Hydraulic System: 1 - Start engine and run for one minute.
2 - Stop engine.
3 - Turn steering wheel. Only slight frame movement should be observed.

NOTE: Differential lock must be disengaged.

NOTE: A significant amount of frame movement would indicate system accumulator pre-charge is low.

Brake: 4 - With engine off, depress brake pedals 20 times.

NOTE: This must be done slowly

If either or both of above checks indicate that accumulators are not functioning properly, they should be serviced immediately.

Accumulators checked Yes No

28. Seat Operation

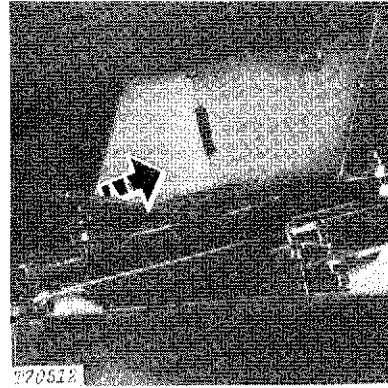

Fig. 85-Seat Release Lever

Check seat operation as follows:

- 1 - Move seat release lever to left.
- 2 - Slide seat to desired position.
- 3 - Release lever. Seat should lock in place.

Seat operation checked Yes No

29. Operation of All Lights

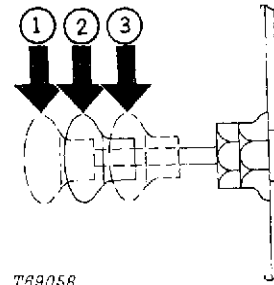

T89058

Fig. 86-Switch Positions

All lights are controlled by light switch located on right side of instrument panel. The light switch has three positions.

This as a preview PDF file from best-manuals.com



Download full PDF manual at best-manuals.com